

# Genetic Factor Analyses of Specific Cognitive Abilities in 5-Year-Old Dutch Children

M. J. H. Rietveld,<sup>1,3</sup> G. C. M. van Baal,<sup>1</sup> C. V. Dolan,<sup>2</sup> and D. I. Boomsma<sup>1</sup>

Received 13 Jan. 1999—Final 3 Sept. 1999

The genetic and environmental factor structures of intellectual abilities in 5-year-old Dutch twins were examined. Six subtests of the RAKIT, a Dutch intelligence test, were administered to 209 twin pairs. The subtests were categorized as either verbal or nonverbal. The genetic covariance structure displayed a two-common factor structure including specific factors to account for subtest residual variance. The correlation between the genetic Verbal and genetic Nonverbal factors did not differ significantly from zero. The shared environmental influence displayed a single-common factor structure. Unique environmental influences did not contribute to the covariance between subtests and were specific in origin. Estimates of heritability of the subtests ranged from 15% to 56%. Shared environmental influences were significantly present, but were modest in magnitude. The phenotypic data was best described by an oblique two-factor model. This model was not mirrored in the factor structures found for either the genetic or environmental covariances.

**KEY WORDS:** Specific cognitive abilities; factor models; heritability; children.

## INTRODUCTION

The factor structure of genetic and environmental influences on specific cognitive abilities measured at one point of time in childhood is investigated in the present study. Six subtests of a Dutch intelligence test were administered to 5-year-old twins. The examination of cognitive abilities is particularly interesting during childhood when rapid accumulation of learning and experience takes place. In school, children are exposed to many novel environmental effects which act specifically on the development of their intellectual abilities. The accumulating effects of these environmental influences may result in a different pattern of cognitive abilities in groups of individuals varying

in age (Reinert, 1970; Schaie *et al.*, 1989; Werdelin and Stjernberg, 1995). The association between age and differentiation of abilities relates to the differentiation hypothesis (Garret, 1946) which suggests that abilities tend to cohere strongly in infancy and childhood, insofar as it is testable. When maturation proceeds, the factorial pattern of intelligence changes and intellectual abilities become more independent from each other.

A useful approach to study the structure of intelligence is factor analysis. A factor model includes a set of common factors to explain the variance shared by various measurements and test-specific factors to explain any residual variance. In a second-order factor model the intercorrelation among the first-order common factors is explained by positing one or more second-order common factors. The intercorrelation among the variables is then decomposed into a part that is attributable to the first-order common factors and into a part that is attributable to the second-order common factors. The hierarchical factor model is a popular multivariate factor technique to examine the structure of

<sup>1</sup> Department of Biological Psychology, Vrije Universiteit, Amsterdam, The Netherlands.

<sup>2</sup> Department of Psychology, Universiteit van Amsterdam, Amsterdam, The Netherlands.

<sup>3</sup> To whom correspondence should be addressed at Vrije Universiteit, Department of Biological Psychology, De Boelelaan 1111, 1081 HV Amsterdam, Fax: +31.20.444.8832. e-mail: mjh.rietveld@psy.vu.nl.

intellectual abilities (Carroll, 1993; Gustafsson, 1984). A hierarchical model presents a general intelligence factor, usually referred to as *g*, as a second-order general factor common to first-order factors. These first-order factors represent various dimensions of intelligence, e.g., verbal and spatial intelligence. As pointed out by Vernon (1965) this model integrates both Spearman's concept of a general cognitive ability (Spearman, 1927) and the Primary Mental Abilities theory of Thurstone (1938).

Studies on the differentiation of cognitive abilities have been summarized by Carroll (Carroll, 1993, p. 677). In his extensive survey of factor-analytic studies, he concluded that the same cognitive ability factors are present at various ages, from the early school years to adulthood and beyond, and that there is no evidence to support the differentiation hypothesis. Two possible explanations that can account for the early differentiation of abilities were proposed. One is that young children already experience a variety of environmental influences which promotes the development of different abilities. Alternatively, the observed distinction between cognitive ability factors at young age may be the result of genetic specificity. Genetic specificity implies that intellectual abilities have no genetic source in common and that genetic effects result from independent sets of genes. The identification of a particular factor model at the observed, phenotypic level is not necessary reflected in the same factor model at the underlying genetic and environmental level. The structure of these genetic and environmental influences can be studied through use of multivariate genetic factor models and requires genetically informative subjects such as twins or adoptees. Application of factor models to such designs can reveal whether an observed association between measures results from a shared genetic source or a shared environmental source, or both. So far, a handful of genetic studies on intellectual abilities and elementary cognitive abilities in children and adults have been carried out using hierarchical or first-order factor models (Cardon *et al.*, 1992; Cardon, 1994; Casto *et al.*, 1995; Finkel *et al.*, 1995; LaBuda *et al.*, 1987; Luo *et al.*, 1994; Pedersen *et al.*, 1994; Petrill *et al.*, 1996; Petrill *et al.*, 1998; Rijdsdijk *et al.*, under revision). Results suggest that one general factor, group factors, and test-specific factors are all required to account for the genetic covariance structure. Shared environmental influences display either a single-common factor structure or a multiple factor structure. Unique environmental influences to variation in cognitive abilities are largely subtest-specific effects. The magnitude of the genetic and environmental influences

appears to be a function of both the tests used and of the sample investigated.

The field of analyzing individual differences in specific cognitive abilities in young children with genetic factor models is relatively unexplored. To our knowledge, the only recent reports on genetic factor models applied to data collected in childhood are reports from the Colorado Adoption Project (CAP). The CAP is a prospective longitudinal adoption study on behavior development starting in infancy (e.g., Plomin and DeFries, 1985). Cardon (1994) reported results of analyses of longitudinal cognitive data collected in adoptees and nonadopted sibling pairs at various ages. A hierarchical model with one second-order factor and four first-order factors was fitted to the data. At age 4, a substantial genetic effect common to the first-order ability factors was found. Heritable variation on the specific subtests was dominated by the effects of these first-order factors and little test-specific genetic effects were found. The unique environmental influences showed considerable ability-specific effects on the first-order common factors. Also, in contrast to the genetic influences, large unique environmental effects specific to each subtest were found. Notably, shared environmental factors contributed little to the observed phenotypic variation at this young age. At the age of 7, the magnitude of genetic and environmental influences changed slightly. Again, the influence of shared environmental factors was nearly absent. The genetic covariance matrix was dominated by a general second-order common factor and the first-order group factors. Compared to age 4, ability-specific genetic effects were found to be greater. Unique environmental influences were primarily subtest-specific in origin.

In an ongoing longitudinal study of brain function (Van Baal, 1997) and cognition in young Dutch twins data on six intelligence subtests were collected in 5-year-old boys and girls. This paper explores the genetic and environmental structure of specific cognitive abilities by evaluating a number of alternative factor models to the six measures of verbal and non-verbal IQ.

## METHODS

### Participants

The participants were 209 twin pairs recruited from the Netherlands Twin Register. The register contains around 50% of all Dutch twins born after 1986 (Boomsma *et al.*, 1992). All 209 pairs participated in a

study of the development of brain-activity and cognitive development at ages 5 and 7 (Van Baal *et al.*, 1996; Boomsma & Van Baal, 1998). Families were selected on the basis of the age and zygosity of the twins, and of their city of residence. Mean age of the children in the present study was 5 years and 3 months (80% within range 5 years and 1 month to 5 years and 6 months). School attendance was 100%; all children were in their first year of formal education.

Zygosity of the same-sex twins was determined by analysis of bloodgroup (142 pairs) or DNA polymorphisms (20 pairs), and in a few cases by physical resemblance (8 pairs). Because one twin did not complete all subtests, the pair was excluded from the genetic analyses. The complete sample comprised 47 monozygotic female (MZF), 37 dizygotic female (DZF), 42 monozygotic male (MZM), 44 dizygotic male (DZM), and 39 dizygotic pairs of opposite sex (DOS). Approximately two years prior to the experiment, information on parental occupation and education was obtained from 186 families by questionnaire. Socioeconomic status (SES) was assessed on a 5-step scale relating to current occupation of the fathers (NCBS, 1993a). Of 186 families, information on occupation was obtained in 178 fathers. The majority of these families (48%) was of middle SES, 24% was of lower SES, and 28% was of higher SES. Parental education was rated on a 7-points scale (NCBS, 1993b). Midparent score for education was positively correlated with the average offspring IQ score ( $r = .29$ ). A correlation of .47 was found for level of education between the spouses.

### Procedure

The brain-activity study required participants to come to the university. After arrival at the laboratory the protocol was explained to the twins and their parents. While one of the twins participated in the electrophysiological experiment, the other twin received the intelligence test which took approximately one hour to administer. IQ of each child was assessed individually by an experienced test-administrator. The whole session, including a break, lasted between three and four hours. All children received a present afterwards.

### Measures

The RAKIT, a Dutch intelligence test, was used in the present study to assess cognitive abilities (Bleichrodt *et al.*, 1984). The RAKIT manual defines intelligence as a multidimensional construct composed of

different factors (Bleichrodt *et al.*, 1987). This definition is closely related to Thurstone's theory of intellectual functioning (Thurstone, 1938). The full-scale test comprises 12 subtests. The concurrent validity with the WISC-R is .86 for total IQ. Raw subtest-scores are standardized to facilitate comparison among performances on subtests. In this study, six subtests of the RAKIT were employed to assess cognitive functioning. The Exclusion subtest measures reasoning by assessing the child's ability to induce a relationship between four figures, and the ability to determine that one of the figures is deviant; the Discs subtest measures spatial orientation and speed of spatial visualization; the Hidden Figures subtest relates to transformation of a visual field, convergence/flexibility of closure; the Verbal Meaning subtest is a vocabulary index and a measure of passive verbal learning; the Learning Names subtest measures active learning and remembering meaningful pictures; the Idea Production measures verbal fluency. The combination of these six subtests has been shown to correlate .93 with the full-scale test score within this age group and is generally accepted as a shortened version of the full-scale test (Bleichrodt *et al.*, 1987). Regarding the nature of the subtests and the way in which the child has to respond it was hypothesized that three subtests load on a Nonverbal factor (Exclusion, Discs, Hidden Figures) and three subtests load on a Verbal factor (Learning Names, Verbal Meaning, Idea Production). The response of the child when performing the nonverbal subtests is to point at the right picture or to move blocks to the proper place. The mode of response to the verbal subtests relates more strongly to language skills.

### Statistical Analyses

Means, standard deviations, variance-covariance matrices, and correlations among IQ subtests were calculated separately for the first and second born twins (twin a and twin b respectively) using SPSS/Windows 7.5. Twin a refers to the boy in opposite-sex twin pairs. We fitted four factor models to the phenotypic data, namely, an oblique two-factor model, an orthogonal two-factor model, a one-factor model, and a model with specifics only. These analyses were conducted in Mx (Neale, 1997), using maximum likelihood estimation of parameters.

PRELIS 2 (Jöreskog and Sörbom, 1993) was used to compute the variance-covariance matrices of the observations, separately for each sex-by-zygosity group. These covariance matrices as well as the cross-twin cross-trait correlations are to be found at the website

of the Netherlands Twin Register, <http://www.psy.vu.nl:80/ntr/>.

### Genetic Modeling

To obtain an estimate of additive genetic (A), shared environmental (C), and unique environmental (E) contributions to the observed variances and covariances between measures, structural equation modeling was employed (Neale and Cardon, 1992). Let  $\Sigma_p$  represent the expected phenotypic covariance matrix between traits. The expected covariance matrix can be partitioned into additive genetic covariance ( $\Sigma_a$ ), into common environmental covariance ( $\Sigma_c$ ) and into unique environmental covariance ( $\Sigma_e$ ) as follows:

$$\Sigma_p = \Sigma_a + \Sigma_c + \Sigma_e$$

First, these three covariance matrices were estimated by means of Cholesky decompositions. Next, a series of oblique first-order factor models was fitted to the data. The oblique factor model is equivalent to a hierarchical factor model with one second-order factor and two first-order factors, where factor loadings of these first-order factors on the second-order factor are constrained to be equal.

The path diagram in Figure 1 represents the most general phenotypic factor model. In view of the nature of the subtests, we considered three different factor models derived from this general model. We started with fitting correlated genetic two-factor models. The path diagram in Figure 2 shows the decomposition of the covariance between subtests into two group factors. This model also includes test-specific effects.

Next, we viewed the subtests as indicators of general intelligence (Jensen, 1998), that is, we fitted a common single-factor model to the covariance matrices. The importance of one general genetic and one general shared and one general unique environmental factor is represented in the path diagram in Figure 3. In this model it is suggested that the observed covariation between the subtests results from one shared, underlying factor at each of the genetic and shared and unique environmental levels. Factors specific to each subtest were added to test for any residual variance.

Finally, the third model that was considered is one in which there are no sources of variation common to the subtests.

The structure of the shared environment was examined first. The various factor structures were evaluated for C, while genetic and unique environmental influences were modeled by Cholesky decompositions.

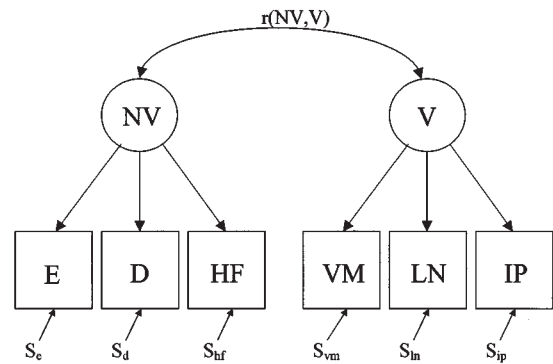

**Fig. 1.** Phenotypic first-order factor model with a Nonverbal factor (NV), a Verbal factor (V) and Specific factors ( $S_e$  to  $S_{ip}$ ) unique to each subtest. NV and V are oblique factors, represented by  $r(NV, V)$ . Exclusion, E; Discs, D; Hidden Figures, HF; Verbal Meaning, VM; Learning Names, LN; Idea Production, IP.

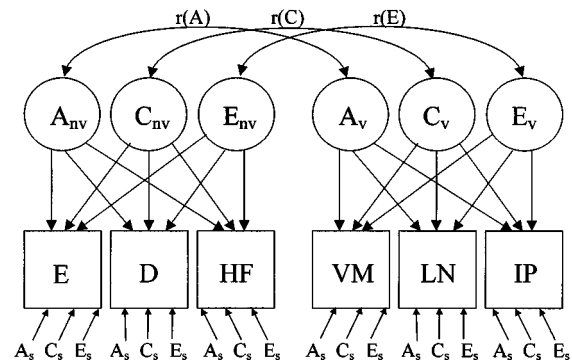

**Fig. 2.** This two-factor model (subscripts nv and v) with test-specifics (subscripts s) suggests that two factors are needed to explain variance among subtests. Proportion of total variance due to genetic, shared and nonshared environmental influences upon factors are represented by A, C, and E, respectively. The double-headed arrow between the Nonverbal and Verbal factor represents a correlation.

The model that best accounted for the shared environmental component was retained in subsequent analyses of the unique environment. Having established the best fitting model for E, this again was retained in examining the structure of the genetic part of the model.

The genetic analyses were performed with the program Mx (Neale, 1997). Mx provides estimates of the parameters in the model and an overall chi-square ( $\chi^2$ ) goodness-of-fit index. If the  $\chi^2$  has a probability smaller than a predetermined value (in this study, for  $\alpha=.05$ ), then the model is rejected and requires modification. The best fitting model in a sequence of models is determined by means of the hierarchical  $\chi^2$  tests. When a more restricted model does not describe the data significantly

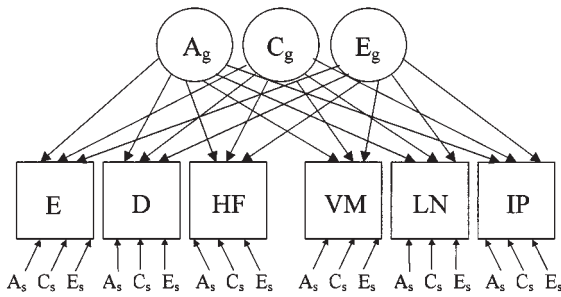

**Fig. 3.** This one-factor model (subscripts *g*) with test-specifics (subscripts *s*) suggests that one general factor explains all covariance among subtests. Proportion of total variance due to genetic, shared and nonshared environmental influences upon factors are represented by A, C, and E, respectively.

worse than the more general model, the most parsimonious model is chosen.

## RESULTS

### Descriptive Statistics

Inspection of the scores on 5 RAKIT subscales showed that the variables were approximately normally distributed (*z*-tests for skewness and kurtosis were non-significant). The distribution of scores on Hidden Figures differed slightly but significantly from a normal distribution (*z*-tests for skewness and kurtosis exceeded 1.96 and  $-1.96$ ). The data were scanned for outliers by visual inspection, but none was found. Mean scores and standard deviations for total IQ and subtests are presented in Table I. No differences in means were found between sexes, between zygositys, or between twin a and twin b. The normative mean score for IQ is 100 ( $SD = 15$ ) and the normative score on each subtest is 15 ( $SD = 5$ ). The majority of the observed means were slightly higher than the population means. However, these differences were not significant for either males or females.

### Phenotypic Analyses

Phenotypic correlations among the subtests are presented in Table II. As mentioned earlier, based on the nature of the subtests and mode of response we hypothesized that Exclusion, Discs, and Hidden Figures load on a Nonverbal factor and Verbal Meaning, Learning Names, and Idea Production load on a Verbal factor. The intercorrelations among subtests loading on the Nonverbal factor (*r* ranging from .26 to .40), and among

subtests loading on the Verbal factor (*r* ranging from .16 to .55) were generally higher than the intercorrelations among subtests from different factors (*r* ranging from .07 to .36). The Nonverbal subtest Exclusion, however, showed a relatively large degree of overlap with Verbal subtests.

Various factor models were specified to investigate the structure of the phenotypic data. These models were fitted to the variance-covariance matrix of twin a and twin b separately. We first applied an oblique two-factor model to the data. The results of this analysis indicated that the fit of the model was acceptable (twin a,  $\chi^2 = 8.23$ ,  $df = 8$ ,  $p = .41$ ; twin b,  $\chi^2 = 16.64$ ,  $df = 8$ ,  $p = .03$ ). Inspection of the data of twin b revealed no systematic source for the deviation from the expected model. The mean intercorrelation among Verbal and Nonverbal subtests was .58 for twin a, and .57 for twin b. This two-factor model is represented by the path diagram in Figure 1. Subsequent reduced models, like an orthogonal two-factor model (twin a,  $\chi^2 = 42.75$ ,  $df = 9$ ,  $p = .00$ ; twin b,  $\chi^2 = 38.87$ ,  $df = 9$ ,  $p = .00$ ), an one-factor model (twin a,  $\chi^2 = 34.04$ ,  $df = 9$ ,  $p = .00$ ; twin b,  $\chi^2 = 37.51$ ,  $df = 9$ ,  $p = .00$ ), and a model with residuals only (twin a,  $\chi^2 = 206.21$ ,  $df = 15$ ,  $p = .00$ ; twin b,  $\chi^2 = 151.97$ ,  $df = 15$ ,  $p = .00$ ) did not lead to an improvement in fit.

### Genetic Analyses

Correlations between twin a and twin b for each subtest for each zygosity group are shown in Table III. Inspecting the correlations of the twins we found higher values for monozygotic twins for all subtests compared to dizygotic twins. Except for Discs, the correlations of monozygotic twins were less than twice the correlations of dizygotic twins suggesting the presence of shared environmental influences.

Results of the Cholesky decomposition and subsequent multivariate factor models are presented in Table IV. No significant difference was found between a Cholesky model with sex differences and a Cholesky model in which estimates for A, C and E were constrained to be equal across sexes ( $\chi^2$  difference = 53.42,  $df = 63$ ,  $p = .80$ ). The genetic and environmental factor loadings derived from the Cholesky decomposition are reported in Table V. No clear pattern emerged from the genetic factor loadings. Formal testing of various factor models is necessary to resolve which factor model best describes the genetic structure. Clearly, a genetic one-factor structure is unlikely because a number of large factor loadings of the second through sixth



**Table I.** Means and Standard Deviations for Subtests and Total IQ-Score for Females and Males. Descriptives are Calculated Separately for Twin a (First Row) and Twin b (Second Row)

|                 | Females ( $N = 207$ ) <sup>a</sup> |       | Males ( $N = 211$ ) |                    |
|-----------------|------------------------------------|-------|---------------------|--------------------|
|                 | Mean                               | SD    | Mean                | SD                 |
| Exclusion       | 15.86                              | 4.27  | 15.40               | 4.36               |
|                 | 15.69                              | 4.15  | 15.40               | 4.38               |
| Discs           | 13.85                              | 4.67  | 13.92               | 5.09               |
|                 | 14.62                              | 4.74  | 13.45               | 5.44               |
| Hidden figures  | 17.03                              | 4.50  | 16.27               | 4.07               |
|                 | 16.60                              | 4.11  | 16.54               | 5.10               |
| Verbal meaning  | 15.14                              | 4.93  | 16.08               | 4.20               |
|                 | 15.83                              | 4.33  | 16.29               | 3.98               |
| Learning names  | 16.38                              | 4.87  | 16.73               | 4.51               |
|                 | 16.80                              | 4.66  | 16.54 <sup>b</sup>  | 4.62 <sup>b</sup>  |
| Idea production | 15.59                              | 4.38  | 14.90               | 4.39               |
|                 | 15.38                              | 4.33  | 15.02               | 3.52               |
| Total IQ        | 102.95                             | 13.98 | 102.48              | 13.33              |
|                 | 103.70                             | 12.92 | 101.55 <sup>b</sup> | 12.74 <sup>b</sup> |

<sup>a</sup>  $N$  = number of participants<sup>b</sup>  $N - 1$ . SD = standard deviation.**Table II.** Phenotypic Pearson Correlations for Subtests for Twin a (Below Diagonal) and Twin b (Above Diagonal)<sup>a</sup>

|                 | Exclusion | Discs             | Hidden figures    | Verbal meaning | Learning names      | Idea production   |
|-----------------|-----------|-------------------|-------------------|----------------|---------------------|-------------------|
| Exclusion       | 1.00      | .32               | .33               | .33            | .21 <sup>b</sup>    | .07 <sup>ns</sup> |
| Discs           | .40       | 1.00              | .26               | .09            | .07 <sup>b,ns</sup> | .12 <sup>ns</sup> |
| Hidden figures  | .26       | .26               | 1.00              | .29            | .19 <sup>b</sup>    | .08 <sup>ns</sup> |
| Verbal meaning  | .36       | .14               | .23               | 1.00           | .43 <sup>b</sup>    | .16               |
| Learning names  | .32       | .14               | .24               | .55            | 1.00                | .29               |
| Idea production | .21       | .10 <sup>ns</sup> | .10 <sup>ns</sup> | .33            | .32                 | 1.00              |

<sup>a</sup>  $N = 209$ .<sup>b</sup>  $N - 1$ . <sup>ns</sup> = nonsignificant correlation,  $p > .05$ .

factor are found. In addition, a model with only genetic specificities is not expected either since the off-diagonal factor loadings are substantial. The interpretation of the pattern of shared environmental factor loadings seems more straightforward. Since large factor loadings are found on the first factor, a one-factor structure is plausible. Regarding the unique environmental effects, specific factors appear important since the largest factor loadings are on the diagonal.

As indicated by the genetic factor loadings derived from the Cholesky decomposition, the genetic correlations varied substantially, ranging from  $-.56$  to  $.91$ . The correlations among subtests which load on either the Nonverbal or Verbal factor did not exhibit consistently higher estimates compared to the intercorrelations among subtests from different factors. As expected, the

correlations calculated for shared environmental effects showed more coherence (range from  $.27$  to  $.94$ ). Correlations between subtests for unique environmental effects were very low (range from  $-.12$  to  $.20$ ).

The Cholesky decomposition without sex differences was taken as a reference for evaluating changes in  $\chi^2$  and associated degrees of freedom of more parsimonious factor models. The structure of the common environmental contribution was investigated first while additive genetic and unique environmental influences were modeled by means of the Cholesky decomposition. Since the shared environmental correlations estimated from the full Cholesky decomposition suggested a one-factor structure, first a model including a General factor and Specifics was applied to the data (Model 3). The fit of this model did not lead to a significant increase

**Table III.** Twin Correlations for IQ Subtests for All Zygosity Groups

|                 | MZF <sup>a</sup><br>(N = 47) | DZF<br>(N = 37) | MZM<br>(N = 42) | DZM<br>(N = 44)  | DOS<br>(N = 39) |
|-----------------|------------------------------|-----------------|-----------------|------------------|-----------------|
| Exclusion       | .47                          | .41             | .71             | .30              | .45             |
| Discs           | .30                          | .16             | .56             | .20              | .34             |
| Hidden figures  | .61                          | .56             | .63             | .23              | .49             |
| Verbal meaning  | .64                          | .38             | .55             | .47              | .54             |
| Learning names  | .80                          | .48             | .68             | .47 <sup>b</sup> | .37             |
| Idea production | .69                          | .38             | .59             | .44              | .35             |

<sup>a</sup> N = number of twin pairs.  
<sup>b</sup> N - 1.

**Table IV.** Model Fit Indices for Cholesky Decomposition and Nested Sequence of Factor Models<sup>a</sup>

| Model  | $\chi^2$ | df  | P   | Tested against | $\Delta\chi^2$ | $\Delta df$ |
|--|----------|-----|-----|----------------|----------------|-------------|
| 1. Cholesky decomposition ACE, + sex differences           | 242.06   | 264 | .83 |                |                |             |
| 2. Cholesky decomposition ACE, no sex differences          | 295.48   | 327 | .89 | 1              | 53.42          | 63          |
| 3. A one-factor structure imposed on C, + Specifics        | 299.08   | 336 | .92 | 2              | 3.60           | 9           |
| 4. Only one factor   | 300.04   | 342 | .95 | 3              | 0.96           | 6           |
| 5. A two-factor structure imposed on E, + Specifics        | 309.18   | 350 | .94 | 4              | 9.14           | 8           |
| 6. A one-factor structure imposed on E, + Specifics        | 311.46   | 351 | .94 | 4              | 11.42          | 9           |
| 7. Only Specifics  | 318.52   | 357 | .93 | 6              | 7.06           | 6           |
| 8. A two-factor structure imposed on A, + Specifics        | 324.02   | 365 | .94 | 7              | 5.5            | 8           |
| 9. Correlation between genetic factors constrained to zero | 324.33   | 366 | .94 | 8              | 0.31           | 1           |
| 10. A one-factor structure imposed on A, + Specifics       | 337.16   | 366 | .86 | 7              | 18.64*         | 9           |
| 11. Only Specifics   | 385.29   | 372 | .31 | 9              | 61.27*         | 6           |

<sup>a</sup>  $\chi^2$  = chi-square,  $\Delta\chi^2$  = change in chi-square, df = degrees of freedom,  $\Delta df$  = change in number of degrees of freedom.  
 \*  $p < .03$ .  $p$ -value for all other  $\Delta\chi^2$  tests  $> .25$ .

in  $\chi^2$ . The test-specific effects explaining residual variance could be omitted from this model without deterioration in fit. This resulted in Model 4 including only one General factor explaining the common environmental variance and covariance ( $\chi^2 = 300.04$ ,  $df = 342$ ,  $p = .95$ ). Next, taking Model 4 as a point of departure, unique environmental effects were examined in a similar way. Model 5 and Model 6 postulated a two-factor structure with Specifics and a one-factor structure with Specifics, respectively. Although both models gave a good description of the data, the most parsimonious model, Model 7, included only Specifics ( $\chi^2 = 318.52$ ,  $df = 357$ ,  $p = .93$ ). This indicated that unique environmental effects did not contribute to the observed covariance between subtests, but only to subtest-specific variance. The concluding analyses investigated the structure of A, additive genetic effects. Model 7 was taken as the new reference model. In Model 7 the shared environmental structure was defined by one General factor, unique environmental in-

fluences were defined by Specifics only, and genetic effects were still specified as a Cholesky decomposition. Application of Model 8, the reduced model including a Nonverbal genetic factor and a Verbal genetic factor with Specifics resulted in a good fit. The correlation between the genetic Nonverbal and Verbal factor was estimated at .10 with the 95% confidence interval ranging from  $-.26$  to  $.10$ . This outcome provided strong evidence for a genetic factor structure with two independent factors. The independency was explicitly tested in Model 9 and this resulted in an adequate description of the data ( $\chi^2 = 324.33$ ,  $df = 366$ ,  $p = .94$ ). More parsimonious models did not fit the data. The importance of each source of variance was tested in various sequences of model fitting. The outcome of each order was identical in the sense that A, C, and E were all found to be indispensable.

Thus, specifying a General factor for the shared environmental effects, Specific factors for the unique environmental effects, and a Nonverbal factor, a Ver-

**Table V.** Genetic (First Panel), Shared Environmental (Second Panel), and Unique Environmental (Third Panel) Factor Loadings Estimated for the Full Cholesky Decomposition<sup>a</sup>

|                 | A-Chol <sub>1</sub> | A-Chol <sub>2</sub> | A-Chol <sub>3</sub> | A-Chol <sub>4</sub> | A-Chol <sub>5</sub> | A-Chol <sub>6</sub> |
|-----------------|---------------------|---------------------|---------------------|---------------------|---------------------|---------------------|
| Exclusion       | 2.40                |                     |                     |                     |                     |                     |
| Discs           | .16                 | 2.02                |                     |                     |                     |                     |
| Hidden figures  | 2.16                | .36                 | 1.14                |                     |                     |                     |
| Verbal meaning  | -.57                | 2.76                | .98                 | .07                 |                     |                     |
| Learning names  | .37                 | 1.22                | -1.99               | -.19                | 0.02                |                     |
| Idea production | -.96                | -.19                | 1.27                | 2.00                | -.60                | .04                 |
|                 | C-Chol <sub>1</sub> | C-Chol <sub>2</sub> | C-Chol <sub>3</sub> | C-Chol <sub>4</sub> | C-Chol <sub>5</sub> | C-Chol <sub>6</sub> |
| Exclusion       | 2.27                |                     |                     |                     |                     |                     |
| Discs           | 2.45                | .96                 |                     |                     |                     |                     |
| Hidden figures  | .81                 | -.16                | 1.78                |                     |                     |                     |
| Verbal meaning  | 2.27                | -.78                | -.40                | .00                 |                     |                     |
| Learning names  | 1.82                | -.74                | 1.56                | .00                 | .00                 |                     |
| Idea production | 1.80                | .39                 | .57                 | .00                 | .00                 | .00                 |
|                 | E-Chol <sub>1</sub> | E-Chol <sub>2</sub> | E-Chol <sub>3</sub> | E-Chol <sub>4</sub> | E-Chol <sub>5</sub> | E-Chol <sub>6</sub> |
| Exclusion       | 2.77                |                     |                     |                     |                     |                     |
| Discs           | .18                 | 2.79                |                     |                     |                     |                     |
| Hidden figures  | .25                 | -.24                | 3.83                |                     |                     |                     |
| Verbal meaning  | .49                 | -.27                | -.10                | 2.43                |                     |                     |
| Learning names  | .22                 | -.35                | .48                 | -.38                | 2.74                |                     |
| Idea production | .28                 | .19                 | .13                 | .33                 | .47                 | 2.52                |

<sup>a</sup> A-Chol<sub>1</sub> to A-Chol<sub>6</sub> = genetic Cholesky factors, C-Chol<sub>1</sub> to C-Chol<sub>6</sub> = shared environmental Cholesky factors, E-Chol<sub>1</sub> to E-Chol<sub>6</sub> = unique environmental Cholesky factors.

bal factor and Specific factors for the additive genetic effects best accounted for the variances and the covariances among subtests. The model is illustrated in Figure 4, with parameter estimates.

The genetic correlations between subtests can easily be calculated from the parameter estimates depicted in Figure 4. Correlations among Nonverbal subtests ranged from .22 to .69, and correlations among Verbal subtests ranged from .32 to .66. The variation in strength of the correlation reflected the influence of test-specific genetic effects. These effects only contributed to the observed variance and not to the observed covariance. Since no significant correlation was found between the genetic Verbal and Nonverbal factor, the intercorrelations among subtests loading on these two factors were zero.

Table VI contains the estimates for the influence of the genetic factors and estimates for shared and unique environmental influences based on Model 9. The parameter estimates for the genetic factors showed no clear pattern. Contribution to the total variance of

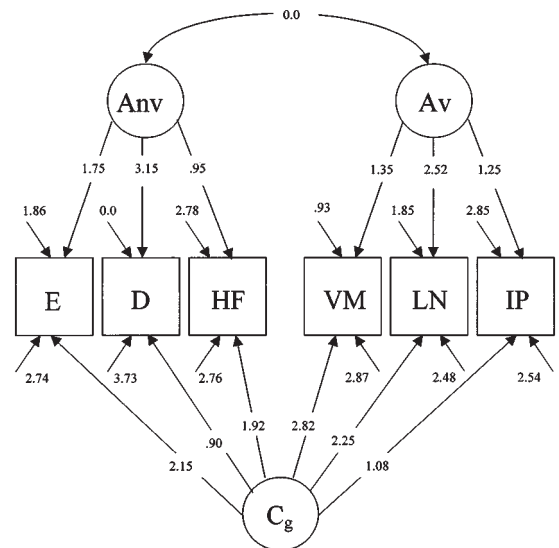

**Fig. 4.** Parameter estimates for best fitting model: two genetic factors (**A<sub>nv</sub>** and **A<sub>v</sub>**), one shared environmental factor (**C<sub>g</sub>**), genetic specifics (single headed arrows placed above squares) and unique environmental specifics (single headed arrows placed below squares).



**Table VI.** Percentages of Total Variance Explained by Nonverbal Genetic Factor, Verbal Genetic Factor, Specific Genetic Factors, and Environmental Factors<sup>a</sup>

|                 | Variance accounted for by genetic and environmental effects (%) |                |                 |                |                |                |
|-----------------|---|----------------|-----------------|----------------|----------------|----------------|
|                 | A <sub>nv</sub>   | A <sub>v</sub> | A <sub>sp</sub> | h <sup>2</sup> | c <sup>2</sup> | e <sup>2</sup> |
| Exclusion       | 16  | -              | 18              | 34             | 25             | 40             |
| Discs           | 40  | -              | 0               | 40             | 3              | 57             |
| Hidden figures  | 5   | -              | 39              | 44             | 18             | 38             |
| Verbal meaning  | -   | 10             | 5               | 15             | 42             | 44             |
| Learning names  | -   | 30             | 16              | 46             | 24             | 29             |
| Idea production | -   | 9              | 47              | 56             | 7              | 37             |

<sup>a</sup> A<sub>nv</sub> = Nonverbal genetic factor, A<sub>v</sub> = Verbal genetic factor, A<sub>sp</sub> = Specific genetic factors. h<sup>2</sup> = proportion of total variance explained by genetic factors, c<sup>2</sup> = proportion of total variance explained by shared environmental factors, e<sup>2</sup> = proportion of total variance explained by unique environmental factors.

the Nonverbal factor ranged from 5% to 40% and the contribution to the total variance of the Verbal factor ranged from 9% to 30%. Hidden Figures shared little variance with other Nonverbal subtests, just as a relatively small loading on the Verbal factor was found for Idea Production. Discs seemed to be a typical Nonverbal subtest; all genetic variance was shared with the other Nonverbal subtests. Looking at the pattern of heritability estimates, no clear distinction could be made between Verbal and Nonverbal tests. On average, the influences of genetic factors and unique environmental factors were of similar magnitude. The influence of shared environmental factors was much more modest. Verbal Meaning was the exception: a large estimate for shared environmental influences was found (42%).

## DISCUSSION

We examined the factorial structure of genetic and environmental influences on specific cognitive abilities by fitting a number of oblique first-order factor models to data on specific cognitive abilities in 5-year-old Dutch twins. Bearing in mind that our sample size is not very large, we first summarize the results and subsequently compare these with findings reported in other studies. An oblique two-factor model gave a good description of the phenotypic covariance matrices. This does not necessarily imply, however, that a two-factor model will adequately describe the genetic and non-genetic covariance structure. It was found that the data were best described by a model with different factor structures for A, C and E. The genetic component of covariance displayed a two-factor structure. The Nonverbal tests loaded on one common genetic factor and the

Verbal tests loaded on the other genetic factor. These two factors were independent. Genetic subtest-specific effects were needed to explain residual variance. The C covariance matrix was dominated by a single factor, accounting for the observed covariance among all subtests. Unique environmental influences were subtest-specific in origin, contributing to the variance specific to the subtests. The estimates for the genetic influences calculated separately for the Nonverbal, Verbal and Specific factors did not exhibit a clear pattern. The Nonverbal genetic factor explained only 5% of the total variance of the Hidden Figures subtest. In contrast, this factor explained all genetic variation in Discs. The genetic two-factor model included a correlation between the genetic Nonverbal and genetic Verbal factor. This correlation was found not to differ significantly from zero. This indicates that the genes influencing Verbal tests are independent from the genes influencing Nonverbal tests. This independency among the two genetic factors implies that the observed covariance between Nonverbal and Verbal tests is solely due to shared environmental influences. The standardized estimates for genetic influences and unique environmental influences were on average of the same magnitude. Genetic estimates ranged from 15% to 56% and unique environmental estimates ranged from 29% to 57%. A large influence of shared environment was found for Verbal Meaning (42%). For the other five subtests this influence was only modest (ranging from 3% to 25%).

The number of reports of genetic analyses on specific cognitive abilities in early childhood and in early school years is limited (Boomsma, 1993; Cardon *et al.*, 1992; Cardon, 1994). The method used in older studies conducted in childhood involved comparison of MZ

correlations with DZ correlations for subtest scores or factor scores (Foch and Plomin, 1980; Garfinkle, 1982; Segal, 1985; Wilson, 1975). While the results in these studies were indicative of genetic variation for some of the measures, not all separate subtest scores displayed heritability. In addition to the report of analyses of separate subtests, Segal (1985) and Wilson (1975) both reported on greater concordance in the pattern of subtest scores in MZ twins compared to DZ twins. The application of various factor models to examine the genetic and environmental covariance structure of specific cognitive abilities using a model fitting approach has just recently gained more attention. A small number of recent studies examining cognitive abilities involved the application of a hierarchical model to data collected in children and adults (Cardon *et al.*, 1992; Cardon, 1994; Luo *et al.*, 1994; Petrill *et al.*, 1996).

Results obtained from twin studies on intelligence in childhood suggest differential heritability for verbal, spatial, memory and perceptual speed tests (reviewed by Plomin, 1986). We did not observe this distinction in estimates of genetic influences between different subtests. Not all subtests in the administered Dutch intelligence test can be classified as purely verbal or purely nonverbal. Although the mode of response is distinctively verbal or nonverbal, the execution of the tasks may partly involve, for example, memory (Learning Names) and, for example, verbal fluency (Idea Production). Therefore, a difference in heritability estimates may arise compared to studies in which more pure subtests or factors are used.

Our results resemble those obtained by Plomin and Vandenberg (1980) in a reanalysis of Koch's (1966) Primary Mental Abilities data obtained in 5- to 7-year-old twins. Plomin and Vandenberg (1980) reported that verbal and spatial abilities, both showing a large genetic influence, are genetically independent at this stage in development. Cardon (1994) applied a hierarchical model to cognitive ability data collected in CAP participants at various ages. Both at ages 4 and 7 years, a genetic general factor was apparent and genetic subtest-specific effects were small. These results are in clear contrast to our findings. Our analyses revealed the presence of two independent genetic factors and genetic subtest-specific effects contributed significantly to the genetic variance. The hierarchical model (Cardon, 1994) also included genetic effects on the group factors independent of *g* with increasing influence from 4 to 7 years. This last finding is more in line with our observation of two separate genetic factors at age 5. In our study, shared

environmental influences were modest but significantly present while Cardon (1994) reported a minimal contribution of *C*. This is quite remarkable since several reviews on developmental intelligence agree upon a large influence of shared environmental factors in early life (e.g., Boomsma, 1993; McCartney *et al.*, 1990; Thompson, 1993).

Most genetic factor analyses have been performed on cognitive ability data collected in participants of older age. Our findings here are to some extent consistent with those reported in studies on specific intellectual abilities in which older samples were examined, even in the elderly (Petrill *et al.*, 1998). Genetic influences are significantly present and environmental influences are largely not shared by members of the same family. Regarding the structure of the latent factors more differences between studies are observed. Some studies reported on substantial ability-specific genetic effects (Casto *et al.*, 1995; LaBuda *et al.*, 1987) while others reported a dominant role of *g* (Pedersen *et al.*, 1994; Petrill, *et al.*, 1998). The significant effects of both a general genetic factor and genetic group factors were reported in studies in which the data were analyzed through application of hierarchical models (Cardon *et al.*, 1992; Luo *et al.*, 1994; Petrill *et al.*, 1996). As in the majority of these studies, we found that a one-factor structure best explained the shared environmental covariance matrix. Among these reports of multivariate analyses most agreement was on unique environmental influences. Those influences are predominantly subtest-specific only.

Boomsma and Van Baal (1998) performed a longitudinal analysis of total IQ data collected in the same sample at ages 5 and 7. Shared environmental factors contributed to half of the observed variance at age 5 while we found a modest contribution of shared environmental factors on specific subtests. This apparent inconsistency arises because the impact of genetic and environmental influences shared by subtests is augmented, and the genetic and environmental influences specific to subtests are decreased when analyzing a composite IQ score (Eaves *et al.*, 1989; p. 201–202). Since our analysis revealed the importance of *C* in explaining the covariance between verbal and nonverbal subtests, a higher estimate of shared environmental factors was detected when analyzing total IQ.

We also collected information on occupation and education in the parents. Parental education showed a positive but moderate correlation with total IQ in their children. The correlation between education of the mother and education of the father was strong (.46).

Although education level is not equivalent to IQ, a strong positive relationship exists (Ceci, 1991). The relationship between education and IQ in parents may have an impact on the estimate of genetic and environmental influences on intelligence in their children. Since IQ is a heritable phenotype in adults, the estimates of shared environmental contributions may be inflated if the resemblance in IQ of spouses is based on phenotypic assortment.

Results from recent studies which focused on the differentiation hypothesis indicated that the same factorial pattern of cognitive abilities is maintained across time (Schaie *et al.*, 1989; Werdelin and Stjernberg, 1995). Behavior genetic factor models provide the means to examine whether this structural invariance at the phenotypic level also applies to the underlying genetic and environmental level. Our results show that at age 5, the phenotypic factor structure differs from the factor structure found for the genetic, shared environmental, and unique environmental sources of variance.

A related issue to the exploration of the factor structure of intellectual abilities is the relationship between cognitive functioning and behavior disorders. This negative association is found in clinical (e.g., Frick *et al.*, 1991) and in healthy populations (e.g., Dietz *et al.*, 1997). The covariance between intelligence and problem behaviors is indicative of a shared source, either environmental or genetic in origin, or both. Considering the findings in this study, an association of behavior problems with both verbal and non-verbal aspects of intelligence would suggest that environmental factors which are shared by children in the same family play a role in explaining the association. A stronger association of either verbal or non-verbal IQ with behavior problems would suggest a common genetic source.

This study is part of an ongoing longitudinal project in which intelligence and behavior problems in childhood are investigated (Van den Oord *et al.*, 1996; Van der Valk *et al.*, 1998). Therefore, we aim to further explore the stability of the genetic and environmental factor structure of cognitive abilities in a longitudinal design, and to examine the relationship between intelligence and problem behaviors.

## ACKNOWLEDGMENTS

This work was financially supported by the USF (grant number 96/22). The authors gratefully acknowledge the assistance of Sophia Kramer with the admin-

istration of the intelligence test. The Netherlands Organization for Scientific Research is acknowledged for funding the work of Caroline van Baal (575-65-052). The research of Conor Dolan was made possible by a fellowship of the Royal Netherlands Academy of Arts and Sciences.

## REFERENCES

- Bleichrodt, N., Drenth, P. J. D., Zaal, J. N., and Resing, W. C. M. (1984). *Revisie Amsterdamse Kinder Intelligentie Test* [Revised Amsterdam Child Intelligence Test], Swets & Zeitlinger B. V., Lisse, The Netherlands.
- Bleichrodt, N., Resing, W. C. M., Drenth, P. J. D., and Zaal, J. N. (1987). *Intelligentie-Meting bij Kinderen. Empirische en Methodologische Verantwoording van de Gereviseerde Kinder Intelligentie Test* [Intelligence-Measurement in Children. Empirical and Methodological Justification of the Revised Child Intelligence Test], Swets & Zeitlinger B. V., Lisse, The Netherlands.
- Boomsma, D. I. (1993). Current status and future prospects in twin studies of the development of cognitive abilities: Infancy to old age. In Bouchard, T. J., Jr., and Propping, P. (eds.), *Twins as a Tool of Behavioral Genetics*, Wiley, Chichester, UK, pp. 67–82.
- Boomsma, D. I., and van Baal, G. C. M. (1998). Genetic influences on childhood IQ in 5- and 7-year-old Dutch twins. *Dev. Neuropsychol.* **14**:115–126.
- Boomsma, D. I., Orlebeke, J. F., and van Baal, G. C. M. (1992). The Dutch Twin Register: Growth data on weight and height. *Behav. Genet.* **22**:247–251.
- Cardon, L. R. (1994). Specific cognitive abilities. In DeFries, J. C., Plomin, R., and Fulker, D. W. (eds.), *Nature and Nurture During Middle Childhood*, Blackwell, Oxford, UK, pp. 57–76.
- Cardon, L. R., Fulker, D. W., DeFries, J. C., and Plomin, R. (1992). Multivariate genetic analysis of specific cognitive abilities in the Colorado Adoption Project at age 7. *Intelligence* **16**:383–400.
- Carroll, J. B. (1993). *Human Cognitive Abilities: A Survey of Factor-Analytic Studies*, Cambridge University Press, Cambridge.
- Casto, S. D., DeFries, J. C., and Fulker, D. W. (1995). Multivariate genetic analysis of Wechsler Intelligence Scale for Children-Revised (WISC-R) factors. *Behav. Genet.* **25**:25–32.
- Ceci, S. J. (1991). How much does schooling influence general intelligence and its cognitive components? A reassessment of the evidence. *Dev. Psychol.* **27**:703–722.
- Dietz, K. R., Lavigne, J. V., Arend, R., and Rosenbaum, D. (1997). Relation between intelligence and psychopathology among preschoolers. *J. Clin. Child Psychol.* **26**:99–107.
- Eaves, L. J., Eysenck, H. J., and Martin, N. G. (1989). *Genes, Culture and Personality: An Empirical Approach*, Oxford University Press, London.
- Finkel, D., Pedersen, N. L., McGue, M., and McClearn, G. E. (1995). Heritability of cognitive abilities in adult twins: Comparison of Minnesota and Swedish data. *Behav. Genet.* **25**:421–431.
- Foch, T. T., and Plomin, R. (1980). Specific cognitive abilities in 5- to 12-year-old twins. *Behav. Genet.* **10**:507–520.
- Frick, P. J., Kamphaus, R. W., Lahey, B. B., Loeber, R., Christ, M. A. G., Hart, E. L., and Tannenbaum, L. E. (1991). Academic underachievement and the disruptive behavior disorders. *J. Consult. Clin. Psychol.* **59**:289–294.
- Garfinkle, A. S. (1982). Genetic and environmental influences on the development of Piagetian locico-mathematical concepts and other specific cognitive abilities: A twin study. *Acta Genet. Med. Gemellol.* **31**:10–61.
- Garret, H. E. (1946). A developmental theory of intelligence. *Am. Psychol.* **1**:372–378.

- Gustafsson, J.-E. (1984). A unifying model for the structure of intellectual abilities. *Intelligence* **8**:179–203.
- Jensen, A. R. (1998). *The g Factor: The Science of Mental Ability*, Praeger Publishers, Westport, CT.
- Jöreskog, K. D., and Sörbom, D. (1993). New Features in PRELIS 2, Scientific Software International, Inc., Chicago.
- Koch, H. L. (1966). *Twins and Twin Relations*. University of Chicago Press, Chicago.
- LaBuda, M. C., DeFries, J. C., and Fulker, D. W. (1987). Genetic and environmental covariance structures among WISC-R subtests: A twin study. *Intelligence* **11**:233–244.
- Luo, D., Petrill, S. A., and Thompson, L. A. (1994). An exploration of genetic *g*: Hierarchical factor analysis of cognitive data from the Western Reserve Twin Project. *Intelligence* **18**:335–347.
- McCartney, K., Harris, M. J., and Bernieri, F. (1990). Growing up and growing apart: A developmental meta-analysis of twin studies. *Psychol. Bull.* **107**:226–237.
- Neale, M. C. (1997). *Mx: Statistical Modeling* (4th Ed.), Department of Psychiatry, Box 126 MCV, Richmond, VA 23298.
- Neale, M. C., and Cardon, L. R. (1992). *Methodology for Genetic Studies of Twins and Families*, Kluwer Academic, Dordrecht, The Netherlands.
- Netherlands Central Bureau of Statistics (1993a). *Standard Beroepen-classificatie 1992* [Standardized Classification of Occupations 1992], Netherlands Central Bureau of Statistics, Voorburg/Heerlen, The Netherlands.
- Netherlands Central Bureau of Statistics (1993b). *Standaard Onderwijsindeling SOI-1978* [Standardized Classification of Education 1978], Netherlands Central Bureau of Statistics, Voorburg/Heerlen, The Netherlands.
- Pedersen, N. L., Plomin, R., and McClearn, G. E. (1994). Is there *G* beyond *g*? (Is there genetic influence on specific cognitive abilities independent of genetic influence on general cognitive ability?). *Intelligence* **18**:133–143.
- Petrill, S. A., Luo, D., Thompson, L. A., and Detterman, D. K. (1996). The independent prediction of general intelligence by elementary cognitive tasks: Genetic and environmental influences. *Behav. Genet.* **26**:135–147.
- Petrill, S. A., Plomin, R., Berg, S., Johansson, B., Pedersen, N. L., Ahern, F. M., and McClearn, G. E. (1998). The genetic and environmental relationship between general and specific cognitive abilities in twins age 80 and older. *Psychol. Sci.* **9**: 183–189.
- Plomin, R. (1986). *Development, Genetics, and Psychology*, Erlbaum Associates, Hillsdale, NJ.
- Plomin, R., and DeFries, J. C. (1985). *Origins of Individual Differences in Infancy: The Colorado Adoption Project*, Academic Press, Orlando, FL.
- Plomin, R., and Vandenberg, S. G. (1980). An analysis of Koch's (1966) primary mental abilities test data for 5- to 7-year-old twins. *Behav. Genet.* **10**:409–412.
- Reinert, G. (1970). Comparative factor analytic studies of intelligence throughout the human life-span. In Goulet L. R., and Baltes, P. B. (eds.), *Life-Span Developmental Psychology*, Academic Press, New York, pp. 467–484.
- Rijsdijk, F. V., Vernon, P. A., and Boomsma, D. I. Application of multivariate genetic models to Raven and WAIS subtests: A Dutch twin study. *Behav. Genet.* (under revision).
- Schaie, K. W., Willis, S. L., Jay, G., and Chipuer, H. (1989). Structural invariance of cognitive abilities across the adult life span: A cross-sectional study. *Dev. Psychol.* **25**:652–662.
- Segal, N. L. (1985). Monozygotic and dizygotic twins: A comparative analysis of mental ability profiles. *Child Dev.* **56**: 1051–1058.
- Spearman, C. (1927). *The Abilities of Man*, MacMillan, London.
- SPSS Inc. (1997). *SPSS Base 7.5 for Windows User's Guide*, SPSS Inc., Chicago, IL.
- Thompson, L. A. (1993). Genetic contributions to intellectual development in infancy and childhood. In Vernon, P. A. (ed.), *Biological Approaches to the Study of Human Intelligence*, Ablex, Norwood, NJ, pp. 95–138.
- Thurstone, L. L. (1938). *Primary Mental Abilities*, Psychometric Monographs, No 1.
- Van Baal, G. C. M. (1997). A Genetic Perspective on the Developing Brain, Doctoral thesis, Vrije Universiteit, Amsterdam.
- Van Baal, G. C. M., de Geus, E. J. C., and Boomsma, D. I. (1996). Genetic architecture of EEG power spectra in early life. *Electroencephalogr. Clin. Neurophysiol.* **98**:502–514.
- Van den Oord, E. J. C. G., Verhulst, F. C., and Boomsma, D. I. (1996). A genetic study of maternal and paternal ratings of problem behaviors in 3-year-old twins. *J. Abnorm. Psychol.* **105**: 349–356.
- Van der Valk, J. C., Verhulst, F. C., Stroet, T. M., and Boomsma, D. I. (1998). Quantitative genetic analysis of internalising and externalising problems in a large sample of 3-year-old twins. *Twin Res.* **1**:25–33.
- Vernon, P. A. (1965). Ability factors and environmental influences. *Am. Psychol.* **20**:723–733.
- Werdelin, I., and Stjernberg, G. (1995). Age differences in factorial structure: A study of the “differentiation hypothesis.” *Interdisciplinaria* **12**:79–97.
- Wilson, R. R. (1975). Twins: Patterns of cognitive development as measured on the Wechsler Preschool and Primary Scale of Intelligence. *Dev. Psychol.* **11**:126–134.