

Agilent Technologies
Modular Power System
Series N6700

Programmer's Reference
Guide



Agilent Technologies

Legal Notices

© Agilent Technologies, Inc. 2006-2008, 2011, 2012

No part of this document may be photocopied, reproduced, or translated to another language without the prior agreement and written consent of Agilent Technologies, Inc. as governed by United States and international copyright laws.

Warranty

The material contained in this document is provided "as is," and is subject to being changed, without notice, in future editions. Further, to the maximum extent permitted by applicable law, Agilent disclaims all warranties, either express or implied, with regard to this manual and any information contained herein, including but not limited to the implied warranties of merchantability and fitness for a particular purpose. Agilent shall not be liable for errors or for incidental or consequential damages in connection with the furnishing, use, or performance of this document or of any information contained herein. Should Agilent and the user have a separate written agreement with warranty terms covering the material in this document that conflict with these terms, the warranty terms in the separate agreement shall control.

Manual Editions

Manual Part Number: N6700-90902
Version 6.0, June 2012
Available in electronic format only.

Certification

Agilent Technologies certifies that this product met its published specifications at time of shipment from the factory. Agilent Technologies further certifies that its calibration measurements are traceable to the United States National Institute of Standards and Technology, to the extent allowed by the Institute's calibration facility, and to the calibration facilities of other International Standards Organization members.

Exclusive Remedies

THE REMEDIES PROVIDED HEREIN ARE THE CUSTOMER'S SOLE AND EXCLUSIVE REMEDIES. AGILENT TECHNOLOGIES SHALL NOT BE LIABLE FOR ANY DIRECT, INDIRECT, SPECIAL, INCIDENTAL, OR CONSEQUENTIAL DAMAGES, WHETHER BASED ON CONTRACT, TORT, OR ANY OTHER LEGAL THEORY.

Assistance

This product comes with the standard product warranty. Warranty options, extended support contacts, product maintenance agreements and customer assistance agreements are also available. Contact your nearest Agilent Technologies Sales and Service office for further information on Agilent Technologies' full line of Support Programs.

Technologies Licenses

The hardware and or software described in this document are furnished under a license and may be used or copied only in accordance with the terms of such license.

U.S. Government Restricted Rights

Software and technical data rights granted to the federal government include only those rights customarily provided to end user customers. Agilent provides this customary commercial license in Software and technical data pursuant to FAR 12.211 (Technical Data) and 12.212 (Computer Software) and, for the Department of Defense, DFARS 252.227-7015 (Technical Data – Commercial Items) and DFARS 227.7202-3 (Rights in Commercial Computer Software or Computer Software Documentation).

Trademarks

Microsoft and Windows are U.S. registered trademarks of Microsoft Corporation.

Contents

1 - Introduction	5
Instrument Drivers and IO Libraries	6
Instrument Web Server	6
Agilent N6700 Product Documentation	7
2 - Introduction to the SCPI Language	9
SCPI Commands	10
SCPI Messages	12
SCPI Conventions and Data Formats	14
SCPI Command Completion	16
3 - Commands by Subsystem	17
ABORt Commands Introduction	18
CALibrate Subsystem Introduction	22
Common Commands Introduction	42
DISPlay Commands Introduction	63
FETCh Subsystem Introduction	66
FORMat Commands Introduction	92
INITiate Subsystem Introduction	94
MEASure Subsystem Introduction	100
OUTPut Subsystem Introduction	124
SENSE Subsystem Introduction	150
SOURce Subsystem Introduction	178
STATus Subsystem Introduction	262
SYSTem Commands Introduction	286
TRIGger Subsystem Introduction	301
4 - Command Quick Reference	321
SCPI Command Summary	322
Non-Volatile Settings	328
Reset Settings (*RST)	329
5 - Programming Examples	331
Output Programming Example	332
List Programming Example	334
Digitizer Programming Example	336
6 - SCPI Error Messages	339
Introduction	340
Error List	340

7 - Agilent 662xA Compatibility.....347
Differences – In General 348
Compatibility Command Summary 349

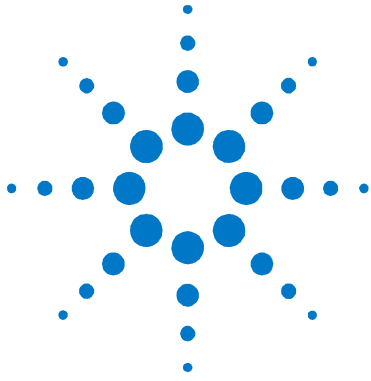

1 Introduction

Instrument Drivers and IO Libraries	6
Instrument Web Server	6
Agilent N6700 Product Documentation	7

This manual contains reference information to help you program the Agilent N6700 Modular Power System over the remote interface using the SCPI programming language. The Agilent N6700 supports the SCPI programming language on all of its remote I/O interfaces. This information applies to the following mainframes:

N6700B,
N6701A,
N6702A.

For additional information on the Agilent N6700, be sure to browse the Product Reference CD-ROM shipped with the instrument or go to www.agilent.com/find/N6700.

Instrument Drivers and IO Libraries

We have included the following drivers and libraries on the Product Reference CD-ROM shipped with your Agilent N6700.

- IVI-COM Drivers
- VXIplug&play Drivers

Agilent IO Libraries are included on a separate *Automation-Ready CD-ROM*, which is also shipped with your Agilent N6700.

You can also download the drivers and libraries from the Agilent web site at www.agilent.com/find/inst_drivers.

Instrument Web Server

The Agilent N6700 has a built-in Web server that lets you control them directly from an internet browser on your computer. With the Web server, you can access the front panel control functions including the LAN configuration parameters.

NOTE

The built-in Web server only operates over the LAN interface. It requires Internet Explorer 6+ or Netscape 6.2+. You also need the Java (Sun) plug-in. This is included in the Java Runtime Environment. Refer to Sun Microsystem's website www.sun.com.

The Web server is enabled when shipped. To launch the Web server:

1. Establish a LAN interface connection from your computer to the Agilent N6700.
2. To launch the Web server, enter the instrument's IP address or fully-qualified hostname into the browser's Address field.
3. To begin controlling your instrument, click on the Browser Web Control button in the navigation bar on the left.
4. For additional Help, click on the Help with this Page button.

Agilent N6700 Product Documentation

The following additional documents are available on the Agilent N6700 Product Reference CD-ROM, shipped with the Agilent N6700.

- N6700 User's Guide
- N6700 Family Specifications Guide
- N6700 Service Guide

NOTE

You can contact Agilent Technologies at one of the following telephone numbers for warranty, service, or technical support information.

In the United States: (800) 829-4444

In Europe: 31 20 547 2111

In Japan: 0120-421-345

Or use our Web link for information on contacting Agilent in your country or specific location: www.agilent.com/find/assist

Or contact your Agilent Technologies Representative.

The web contains the most up to date version of the manuals. Go to www.agilent.com/find/N6700 to get the latest version of the manuals.

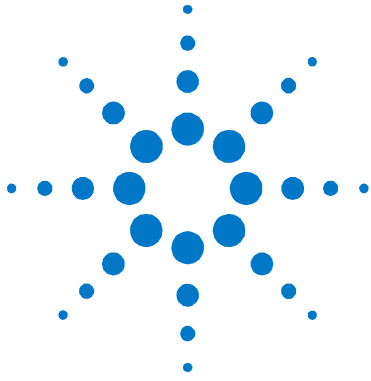

2

Introduction to the SCPI Language

SCPI Commands	10
SCPI Messages	12
SCPI Conventions and Data Formats	14
SCPI Command Completion	16

This chapter contains a brief introduction to the SCPI Programming language.

SCPI (Standard Commands for Programmable Instruments) is a programming language for controlling test and measurement instruments. SCPI provides instrument control with a standardized command syntax and style, as well as a standardized data interchange format.

SCPI Commands

SCPI has two types of commands, common and subsystem.

- **Common commands** are defined by the IEEE 488.2 standard to perform common interface functions such as reset, status, and synchronization. All common commands consist of a three-letter mnemonic preceded by an asterisk: *RST *IDN? *SRE 8.
- **Subsystem commands** perform specific instrument functions. They can be a single command or a group of commands. The groups are comprised of commands that extend one or more levels below the root. Subsystem commands are arranged alphabetically according to the function they perform. The following figure shows a portion of a subsystem command tree, from which you access the commands located along the various paths. Some [optional] commands have been included for clarity.

```
:OUTput
  [:STATe] <Bool>, (@<chanlist>)
  :DELay
    :FALL <NRf+>, (@<chanlist>)
    :RISE <NRf+>, (@<chanlist>)
  :INHibit
    :MODE <mode>

:STATus
  :OPERation
    [:EVENT]? (@<chanlist>)
    :CONDition? (@<chanlist>)
```

Multiple Commands in a Message

Multiple SCPI commands can be combined and sent as a single message with one message terminator. There are two important considerations when sending several commands within a single message:

- Use a semicolon to separate commands within a message.
- There is an implied header path that affects how commands are interpreted by the instrument.

The header path can be thought of as a string that gets inserted **before** each command within a message. For the first command in a message, the header path is a null string. For each subsequent command the header path is defined as the characters that make up the headers of the previous command in the message up to and including the last colon separator. An example of a message with two commands is:

```
OUTPut:STATe ON, (@1);PROTection:CLEar (@1)
```

which shows the use of the semicolon separating the two commands, and also illustrates the header path concept. Note that with the second command, the leading header "OUTPut" was omitted because

after the "OUTPut:STATe ON" command, the header path became defined as "OUTPut" and thus the instrument interpreted the second command as:

```
OUTPut:PROTection:CLEar (@1)
```

In fact, it would have been syntactically incorrect to include the "OUTPut" explicitly in the second command, since the result after combining it with the header path would be:

```
OUTPut:OUTPut:PROTection:CLEar (@1)
```

which is incorrect.

Moving Among Subsystems

In order to combine commands from different subsystems, you need to be able to reset the header path to a null string within a message. You do this by beginning the command with a colon (:), which discards any previous header path. For example, you could clear the output protection and check the status of the Operation Condition register in one message by using a root specifier as follows:

```
OUTPut:PROTection:CLEar (@1)::STATus:OPERation:CONDition? (@1)
```

The following message shows how to combine commands from different subsystems as well as within the same subsystem:

```
VOLTage:LEVel 7.5,(@1);PROTection 10,(@1)::CURRENT:LEVel 0.5,(@1)
```

Note the use of the optional header LEVel to maintain the correct path within the subsystems, and the use of the root specifier to move between subsystems.

Including Common Commands

You can combine common commands with subsystem commands in the same message. Treat the common command as a message unit by separating it with a semicolon (the message unit separator). Common commands *do not affect the header path*; you may insert them anywhere in the message.

```
OUTPut OFF,(@1);*RCL 1;OUTPut ON,(@1)
```

Using Queries

Observe the following precautions with queries:

- Add a blank space between the query indicator (?) and any subsequent parameter such as a channel list.
- Allocate the proper number of variables for the returned data.
- Read back all the results of a query before sending another command to the instrument. Otherwise, a *Query Interrupted* error will occur and the unreturned data will be lost.

Coupled Commands

When commands are coupled it means that the value sent by one command is affected by the settings of another command. The following commands are coupled:

- [SOURce:]CURRent and [SOURce:]CURRent:RANGe.
- [SOURce:]VOLTage and [SOURce:]VOLTage:RANGe.

If a range command is sent that places an output on a range with a lower maximum setting than the present level, an error is generated. This also occurs if a level is programmed with a value too large for the present range.

These types of errors can be avoided by sending the both level and range commands as a set, in the same SCPI message. For example,

```
CURRent 10,(@1);CURRent:RANGe 10,(@1)<NL>
```

will always be correct because the commands are not executed until the message terminator is received. Because the range and setting information is received as a set, no range/setting conflict occurs.

SCPI Messages

There are two types of SCPI messages, program and response.

- A **program message** consists of one or more properly formatted SCPI commands sent from the controller to the instrument. The message, which may be sent at any time, requests the instrument to perform some action.
- A **response message** consists of data in a specific SCPI format sent from the instrument to the controller. The instrument sends the message only in response to a query header.

The following figure illustrates the SCPI message structure.

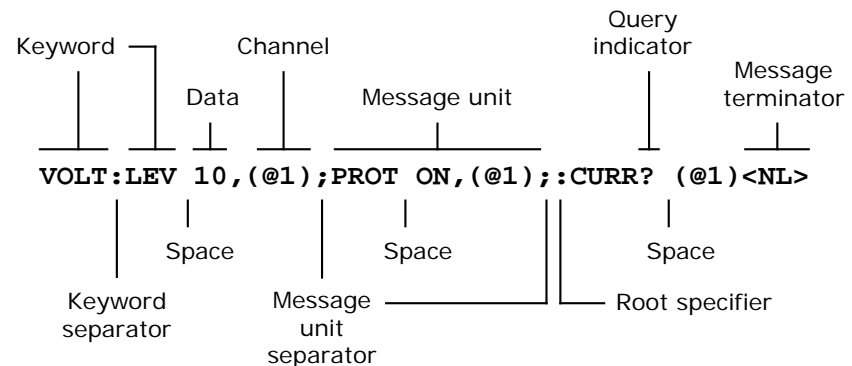

The Message Unit

The simplest SCPI command is a single message unit consisting of a command header (or keyword) followed by a message terminator such as a newline. The message unit may include a parameter after the header. The parameter can be numeric or a string.

```
*RST<NL>
VOLTage 20, (@1) <NL>
```

Channel List Parameter

The channel parameter is required to address one or more channels. It has the following syntax:

```
(@<channel> [ , <channel> ] [ , <channel> ] [ , <channel> ] )
```

You can also specify a range of sequential channels as follows:

```
(@<start_channel> : <end_channel> )
```

For example, (@2) specifies channel 2 and (@1:3) specifies channels 1 through 3. The channel list, shown as <chanlist> throughout this document, must be preceded with the @ symbol and must be enclosed in parentheses (). A maximum of 4 channels may be specified through a combination of single channels and ranges. Query results are channel list order-sensitive. Results are returned in the order they are specified in the list.

NOTE

When adding a channel list parameter to a query, you must include a space character between the query indicator (?) and the channel list parameter. Otherwise error -103, Invalid separator will occur.

Headers

Headers, also referred to as keywords, are instructions recognized by the instrument. Headers may be in the long form or in the short form. In the long form, the header is completely spelled out, such as VOLTAGE, STATUS, and DELAY. In the short form, the header has only the first three or four letters, such as VOLT, STAT, and DEL.

When the long form notation is used in this document, the capital letters indicate the equivalent short form. For example, MEASure is the long form, and MEAS indicates the short form equivalent.

Query Indicator

Following a header with a question mark turns it into a query (VOLTage?, VOLTage:TRIGgered?). The ? is the query indicator. If a query contains parameters, place the query indicator at the end of the last header, before the parameters.

```
VOLTage:TRIGgered? MAX, (@1)
```

Message Unit Separator

When two or more message units are combined into a compound message, separate the units with a semicolon.

```
STATus:OPERation? (@1);QUEStionable? (@1)
```

Root Specifier

When it precedes the first header of a message unit, the colon becomes the root specifier. It tells the command parser that this is the root or the top node of the command tree.

Message Terminator

A terminator informs SCPI that it has reached the end of a message. The following messages terminators are permitted:

- newline <NL>, which is ASCII decimal 10 or hex 0A.
- end or identify <END> (EOI with ATN false)
- both of the above <NL><END>
- also <CR><NL>

In the examples of this guide, there is an assumed message terminator at the end of each message.

SCPI Conventions and Data Formats

Conventions

The following SCPI conventions are used throughout this guide.

Angle brackets < >	Items within angle brackets are parameter abbreviations. For example, <NR1> indicates a specific form of numerical data.
Vertical bar	Vertical bars separate alternative parameters. For example, VOLT CURR indicates that either "VOLT" or "CURR" can be used as a parameter.
Square brackets []	Items within square brackets are optional. The representation [SOURce:]VOLTage means that SOURce: may be omitted.
Parentheses ()	Items within parentheses are used in place of the usual parameter types to specify a channel list. The notation (@1:3) specifies a channel list that includes channels 1, 2, and 3. The notation (@1,3) specifies a channel list that includes only channels 1 and 3.
Braces { }	Braces indicate parameters that may be repeated zero or more times. It is used especially for showing arrays. The notation <A>{} shows that parameter "A" must be entered, while parameter "B" may be omitted or may be entered one or more times.

Data Formats

Data programmed or queried from the instrument is ASCII. The data may be numerical or character string.

Numeric and Character Data Formats

Symbol	Description
<NR1>	Numeric value with an implied decimal point assumed at the right of the least-significant digit. Examples: 273
<NR2>	Numeric value with an explicit decimal point. Example: 27.3
<NR3>	Numeric value with an explicit decimal point and an exponent. Example: 2.73E+02
<NRf>	Extended format that includes <NR1>, <NR2> and <NR3>. Examples: 273 27.3 2.73E+02
<NRf+>	Expanded decimal format that includes <NRf> and MIN, MAX. Examples: 273 27.3 2.73E+02 MAX. MIN and MAX are the minimum and maximum limit values that are implicit in the range specification for the parameter.
<Bool>	Boolean Data. They can be numeric (0, 1), or named (OFF, ON).
<SPD>	String Program Data. Predefined symbolic string parameter enclosed in single or double quotes.
<CPD>	Character Program Data. Predefined symbolic discrete parameter. Accepts both the short form and the long form.
<SRD>	String Response Data. Predefined symbolic string parameter enclosed in single or double quotes.
<CRD>	Character Response Data. Predefined symbolic discrete parameter. Only the short form of the parameter is returned.
<AARD>	Arbitrary ASCII Response Data. Permits the return of undelimited 7-bit ASCII. This data type has an implied message terminator.
<Block>	Arbitrary Block Response Data. Permits the return of definite length and indefinite length arbitrary response data. This data type has an implied message terminator.

Suffixes and Multipliers

Class	Suffix	Unit	Unit with Multiplier
Current	A	ampere	MA (milliampere)
Amplitude	V	volt	UV (microvolt)
Time	S	second	KS (kilosecond)
Common Multipliers			
1E3	K	kilo	
1E-3	M	milli	
1E-6	U	micro	

SCPI Command Completion

SCPI commands sent to the instrument are processed either sequentially or in parallel. Sequential commands finish execution before a subsequent command begins. Parallel commands allow other commands to begin executing while the parallel command is still executing.

The following is a list of parallel commands. You should use some form of command synchronization as discussed in this section before assuming that these commands have completed.

OUTPut:STATE	INITiate
VOLTage	OUTPut:PROTEction:CLEar
CURRent	FUNCTion:MODE

The *WAI, *OPC, and *OPC? common commands provide different ways of indicating when all transmitted commands, including any parallel ones, have completed their operations. Some practical considerations for using these commands are as follows:

- *WAI** This command prevents the instrument from processing subsequent commands until all pending operations are completed. For example, the *WAI command can be used to make a voltage measurement after an OUTPut ON command has completed:

```
OUTPut ON, (@1); *WAI; :MEASure:VOLTage? (@1)
```

- *OPC?** This command places a 1 in the Output Queue when all pending operations have completed. Because it requires your program to read the returned value before executing the next program statement, *OPC? can be used to cause the controller to wait for commands to complete before proceeding with its program.

- *OPC** This command sets the OPC status bit when all pending operations have completed. Since your program can read this status bit on an interrupt basis, *OPC allows subsequent commands to be executed.

NOTE

The trigger subsystem must be in the Idle state for the status OPC bit to be true. As far as triggers are concerned, OPC is false whenever the trigger subsystem is in the Initiated state.

Device Clear

You can send a Device Clear at any time to abort a SCPI command that may be hanging up the GPIB interface. Device Clear clears the input and output buffers of the instrument and prepares the instrument to accept a new command string. The status registers, error queue, and all configuration states are left unchanged by Device Clear. The following statement shows how to send a device clear over the GPIB interface using Agilent Basic:

```
CLEAR 705 IEEE-488 Device Clear
```

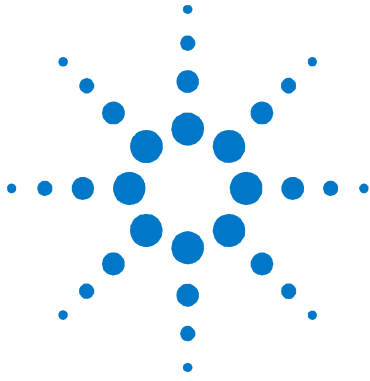
3

Commands by Subsystem

ABORt Commands Introduction	18
CALibrate Subsystem Introduction	22
Common Commands Introduction	42
DISPlay Commands Introduction	63
FETCh Subsystem Introduction	66
FORMat Commands Introduction	92
INITiate Subsystem Introduction	94
MEASure Subsystem Introduction	100
OUTPut Subsystem Introduction	124
SENSe Subsystem Introduction	150
SOURce Subsystem Introduction	178
STATus Subsystem Introduction	262
SYSTem Commands Introduction	286
TRIGger Subsystem Introduction	301

This section gives the syntax and parameters for all the IEEE 488.2 SCPI commands and the Common commands used by the instrument. It is assumed that you are familiar with the material in chapter 2, which explains the terms, symbols, and syntactical structures used here and gives an introduction to programming. You should also be familiar with chapter 4 in the User's Guide, in order to understand how the instrument functions.

Subsystem commands are specific to instrument functions. They can be a single command or a group of commands. The groups are comprised of commands that extend one or more levels below the root. The subsystem commands are arranged alphabetically according to the function they perform.

Common commands are defined by the IEEE 488.2 standard to perform common interface functions. They begin with an * and consist of three letters (command) or three letters and a ? (query). Common commands are grouped along with the subsystem commands according to the function they perform.

ABORt Commands Introduction

Abort commands cancel any triggered actions.

SCPI Command	Description
ABORt	
:ACQuire (@chanlist)	Resets the measurement trigger system to the Idle state
:ELOG (@chanlist)	Stops the external datalogger
:TRANsient (@chanlist)	Resets the transient trigger system to the Idle state

ABORt:ACQuire

Syntax

ABORt:ACQuire (@<chanlist>)

Description

This command cancels any triggered measurements and returns the trigger system back to the Idle state. It also resets the WTG-meas bit in the Condition Status register.

Parameters

Name	Type	Range of Values	Default Value
<chanlist>	Numeric	One or more channels. (@2) - channel 2 (@1,4) - channels 1 and 4 (@1:3) - channels 1 through 3.	Required parameter

Remarks

ABORt:ACQuire is also executed at power-on and upon execution of the [*RST](#) command.

Example

The following command aborts the triggered action of channel 1.

```
ABOR:ACQ (@1)
```

See Also

[*RST](#)

[ABORt:TRANsient](#)

ABORt:ELOG

Syntax

ABORt:ELOG (@<chanlist>)

Description

This command stops the external data log and returns the trigger system back to the Idle state.

Parameters

Name	Type	Range of Values	Default Value
<chanlist>	Numeric	One or more channels. (@2) - channel 2 (@1,4) - channels 1 and 4 (@1:3) - channels 1 through 3.	Required parameter

Example

The following command stops the external data log on channel 1.

```
ABOR:ELOG (@1)
```

ABORt:TRANsient

Syntax

ABORt:TRANsient (@<chanlist>)

Description

This command cancels any triggered actions and returns the trigger system back to the Idle state. ABORt:TRANsient also resets the WTG-tran bit in the Operation Condition Status register.

Parameters

Name	Type	Range of Values	Default Value
<chanlist>	Numeric	One or more channels. (@2) - channel 2 (@1,4) - channels 1 and 4 (@1:3) - channels 1 through 3.	Required parameter

Remarks

If INITiate:CONTinuous:TRANsient ON has been programmed, ABORt does not turn off continuous triggers.

ABORt:TRANsient is also executed at power-on and upon execution of the [*RST](#) command.

Example

The following command aborts the triggered action of channel 1.

```
ABOR:TRAN (@1)
```

See Also

[*RST](#)

[ABORt:ACQuire](#)

[INITiate:CONTinuous:TRANsient](#)

CALibrate Subsystem Introduction

This subsystem lets you calibrate the instrument. Only one channel can be calibrated at a time.

If calibration mode has not been enabled with CALibrate:STATe, the calibration commands will generate an error. Use CALibrate:SAVE to save any changes, otherwise all changes will be lost when you exit calibration mode.

NOTE

Refer to Chapter 3 in the Service Guide for a detailed description of the calibration procedure.

SCPI Command	Description
CALibrate	
:CURRent	
[:LEVel] <NRf>, (@channel)	Calibrates the output current programming
:LIMit	
:NEGative <NRf>, (@channel)	Calibrates the negative current limit (only on N6783A)
:POSitive <NRf>, (@channel)	Calibrates the positive current limit (only on N678xA SMU)
:MEASure <NRf>, (@channel)	Calibrates the current measurement
:PEAK (@channel)	Calibrates the peak current limit (only on N675xA, N676xA)
:DATA <NRf>	Enters the calibration value
:DATE <"date">, (@channel)	Sets the calibration date
:DPRog (@channel)	Calibrates the current downprogrammer
:LEVel P1 P2 P3	Advances to the next calibration step
:PASSword <NRf>	Sets the numeric calibration password
:RESistance 20 6, (@channel)	Calibrates the output resistance (only on N6781A)
:SAVE	Saves the new cal constants in non-volatile memory
:STATE <Bool> [,<NRf>]	Enables/disables calibration mode
:VOLTage	
[:LEVel] <NRf>, (@channel)	Calibrates the output voltage programming
:CMRR (@channel)	Calibrates common mode rejection ratio (only N675xA, N676xA)
:LIMit	
:POSitive <NRf>, (@channel)	Calibrates the positive voltage limit (only on N678xA SMU)
:MEASure <NRf>, (@channel)	Calibrates the voltage measurement
:AUXiliary (@channel)	Calibrates the auxiliary voltage measurement (only on N6781A)

CALibrate:CURRent[:LEVel]**Syntax**

```
CALibrate:CURRent[:LEVel] <value>, (@<channel>)
```

Description

This command initiates calibration of the output current. The value that you enter selects the range that is being calibrated.

NOTE

Refer to Chapter 3 in the Service Guide for a detailed description of the calibration procedure.

Parameters

Name	Type	Range of Values	Default Value
<value>	NRf	The maximum current of the range that is being calibrated.	Required parameter
<channel>	NR1	The output channel that is being calibrated.	Required parameter

Example

The following command calibrates the current of channel 1.

```
CAL:CURR 10.2, (@1)
```

See Also

[CALibrate:CURRent:MEASure](#)

[CALibrate:CURRent:PEAK](#)

CALibrate:CURRent:LIMit:NEGative**Syntax**

```
CALibrate:CURRent:LIMit:NEGative <value>,
(@<channel>)
```

Description

This command initiates calibration of the negative current limit. The value is programmed in amperes and must be specified as negative. The value that you enter selects the range that is being calibrated. There is only one negative current range.

NOTE

This command only applies to models N6783A. Refer to Chapter 3 in the Service Guide for a detailed description of the calibration procedure.

Parameters

Name	Type	Range of Values	Default Value
<value>	NRf	The maximum current of the range that is being calibrated.	Required parameter
<channel>	NR1	The output channel that is being calibrated.	Required parameter

Example

The following command calibrates the negative current limit of channel 1.

```
CAL:CURR:LIM:NEG -2,(@1)
```

See Also

[CALibrate:CURRent:MEASure](#)

CALibrate:CURRent:LIMit:POSitive

Syntax

```
CALibrate:CURRent:LIMit:POSitive <value>,  
(@<channel>)
```

Description

This command initiates calibration of the positive current limit. The value that you enter selects the range that is being calibrated.

NOTE

This command only applies to models N678xA SMU. Refer to Chapter 3 in the Service Guide for a detailed description of the calibration procedure.

Parameters

Name	Type	Range of Values	Default Value
<value>	NRf	The maximum current of the range that is being calibrated.	Required parameter
<channel>	NR1	The output channel that is being calibrated.	Required parameter

Example

The following command calibrates the positive current limit of channel 1.

```
CAL:CURR:LIM:POS 3,(@1)
```

See Also

[CALibrate:CURRent:MEASure](#)

CALibrate:CURRent:MEASure

Syntax

```
CALibrate:CURRent:MEASure <value>, (@<channel>)
```

Description

This command initiates calibration of the current measurement range. The value that you enter selects the range that is being calibrated.

NOTE

Refer to Chapter 3 in the Service Guide for a detailed description of the calibration procedure.

Parameters

Name	Type	Range of Values	Default Value
<value>	NRf	The maximum current of the range that is being calibrated.	Required parameter
<channel>	NR1	The output channel that is being calibrated.	Required parameter

Example

The following command calibrates the current measurement range of channel 1.

```
CAL:CURR:MEAS 10.2, (@1)
```

See Also

[CALibrate:CURRent\[:LEVel\]](#)

[CALibrate:CURRent:PEAK](#)

CALibrate:CURRent:PEAK

Syntax

CALibrate:CURRent:PEAK (@<channel>)

Description

This command initiates calibration of the peak current limit.

NOTE

This command only applies to models N675xA and N676xA. Refer to Chapter 3 in the Service Guide for a detailed description of the calibration procedure.

Parameters

Name	Type	Range of Values	Default Value
<channel>	NR1	The output channel that is being calibrated.	Required parameter

Example

The following command calibrates the peak current limit of channel 1.

```
CAL:CURR:PEAK (@1)
```

See Also

[CALibrate:CURRent\[:LEVel\]](#)

[CALibrate:CURRent:MEASure](#)

CALibrate:DATA

Syntax

CALibrate:DATA <value>

Description

This command enters a calibration value that you obtain by reading an external meter. You must first select a calibration level (with CALibrate:LEVel) for the value being entered. Data values are expressed in base units - either volts or amperes, depending on which function is being calibrated.

NOTE

Refer to Chapter 3 in the Service Guide for a detailed description of the calibration procedure.

Parameters

Name	Type	Range of Values	Default Value
<value>	NRf	The measured voltage or current value.	Required parameter

Example

The following command enters a value measured by an external meter.

```
CAL:DATA 10.01
```

See Also

[CALibrate:LEVel](#)

CALibrate:DATE

Syntax

```
CALibrate:DATE <"date">, (@<channel>)
```

```
CALibrate:DATE? (@<channel>)
```

Description

This command stores the date that the power module was last calibrated. The calibration date is stored in nonvolatile memory. Enter any ASCII string up to 16 characters. The query returns the date.

NOTE

Refer to Chapter 3 in the Service Guide for a detailed description of the calibration procedure.

Parameters

Name	Type	Range of Values	Default Value
<"date">	SPD	String program data. String parameters must be enclosed in single or double quotes.	Required parameter
<channel>	NR1	The output channel that is being calibrated.	Required parameter

Remarks

The firmware does not interpret the string format. The information is not used by the firmware. The command is only provided to store the calibration date.

Return Format

```
<SRD>
```

The query command returns an ASCII string enclosed in double quotes. If no date is stored, an empty quoted string ("") is returned.

Example

The following command enters a date.

```
CAL:DATE "4/22/11", (@1)
```

The following query returns the calibration date.

```
CAL:DATE? (@1)
```

Typical Response: "April 22, 2011"

CALibrate:DPRog

Syntax

CALibrate:DPRog (@<channel>)

Description

This command initiates calibration of the current downprogrammer.

NOTE

Refer to Chapter 3 in the Service Guide for a detailed description of the calibration procedure.

Parameters

Name	Type	Range of Values	Default Value
<channel>	NR1	The output channel that is being calibrated.	Required parameter

Example

The following command calibrates the current downprogrammer of channel 1.

```
CAL:DPR (@1)
```

CALibrate:LEVel

Syntax

CALibrate:LEVel <level>

Description

This command is used to advance to the next level in the calibration. P1 is the first calibration level; P2 is the second level; P3 is the third level.

NOTE

Refer to Chapter 3 in the Service Guide for a detailed description of the calibration procedure.

Parameters

Name	Type	Range of Values	Default Value
<level>	CPD	P1 P2 P3	Required parameter

Remarks

Some calibration sequences may require some settling time after sending CAL:LEV but before reading the data from the DVM and sending CAL:DATA.

Example

The following command selects the first calibration level.

```
CAL:LEV P1
```

See Also

[CALibrate:DATA](#)

CALibrate:PASSword

Syntax

CALibrate:PASSword <password>

Description

This command lets you change the calibration password. The new password is automatically stored in nonvolatile memory and does not have to be stored with CALibrate:SAVE. If the password is set to 0, password protection is removed and the ability to enter calibration mode is unrestricted. The factory-default password 0 (zero).

NOTE

Refer to Chapter 3 in the Service Guide for a detailed description of the calibration procedure.

Parameters

Name	Type	Range of Values	Default Value
<password>	NRf	A numeric value up to 15 digits in length.	Required parameter

Example

The following command sets the password to a value of 1234.

```
CAL:PASS 1234
```

CALibrate:RESistance

Syntax

```
CALibrate:RESistance <range> , (@<channel>)
```

Description

This command initiates calibration of the output resistance.

NOTE

This command only applies to model N6781A. Refer to Chapter 3 in the Service Guide for a detailed description of the calibration procedure.

Parameters

Name	Type	Range of Values	Default Value
<range>	Numeric	20 6	20 V
<channel>	NR1	The output channel that is being calibrated.	Required parameter

Example

The following command calibrates the output resistance of the 20 V range of channel 1.

```
CAL:RES 20 , (@1)
```

CALibrate:SAVE

Syntax

```
CALibrate:SAVE
```

Description

This command saves calibration constants in non-volatile memory after the calibration procedure has been completed. If calibration mode is exited by programming CALibration:STAtE OFF without first saving the new constants, the previous constants are restored.

NOTE

Refer to Chapter 3 in the Service Guide for a detailed description of the calibration procedure.

Example

The following command saves the calibration values.

```
CAL:SAVE
```

See Also

[CALibrate:STAtE](#)

CALibrate:STATe

Syntax

```
CALibrate:STATe <Bool>, [<password>]
```

```
CALibrate:STATe?
```

Description

This command enables or disables calibration mode. Calibration mode must be enabled for the instrument to accept any calibration commands. The first parameter specifies the ON (1) or OFF (0) state. The second parameter is the password.

A numeric password is required if calibration mode is being enabled and the existing password is not 0. If the password is not entered or is incorrect, an error is generated and the calibration mode remains disabled.

NOTE

Refer to Chapter 3 in the Service Guide for a detailed description of the calibration procedure.

Parameters

Name	Type	Range of Values	Default Value
<Bool>	Boolean	OFF 0 ON 1	OFF
<password>	NRf	A numeric value up to 15 digits in length.	Required if password not 0

Remarks

When the calibration state is changed from enabled to disabled, new calibration constants are lost unless they have already been stored with CALibrate:SAVE.

Return Format

```
<NR1>
```

The query returns only the calibration state, not the password. It returns either 0 (OFF), or 1 (ON).

Example

The following command enables calibration mode; the password is 1234.

```
CAL:STAT ON, 1234
```

The following query returns the calibration state.

```
CAL:STAT?
```

Typical Response: 1

See Also

[CALibrate:SAVE](#)

CALibrate:VOLTage[:LEVel]**Syntax**

```
CALibrate:VOLTage[:LEVel] <value>, (@<channel>)
```

Description

This command initiates calibration of the output voltage. The value that you enter selects the range that is being calibrated.

NOTE

Refer to Chapter 3 in the Service Guide for a detailed description of the calibration procedure.

Parameters

Name	Type	Range of Values	Default Value
<value>	NRf	The maximum voltage of the range that is being calibrated.	Required parameter
<channel>	NR1	The output channel that is being calibrated.	Required parameter

Example

The following command calibrates the voltage of channel 1.

```
CAL:VOLT 51, (@1)
```

See Also

[CALibrate:VOLTage:MEASure](#)

[CALibrate:VOLTage:CMRR](#)

CALibrate:VOLTage:CMRR

Syntax

CALibrate:VOLTage:CMRR (@<channel>)

Description

This command initiates calibration of the voltage common mode rejection ratio.

NOTE

This command only applies to models N675xA and N676xA. Refer to Chapter 3 in the Service Guide for a detailed description of the calibration procedure.

Parameters

Name	Type	Range of Values	Default Value
<channel>	NR1	The output channel that is being calibrated.	Required parameter

Example

The following command calibrates the voltage common mode rejection ratio of channel 1.

```
CAL:VOLT:CMRR (@1)
```

See Also

[CALibrate:VOLTage\[:LEVel\]](#)

[CALibrate:VOLTage:MEASure](#)

CALibrate:VOLTage:LIMit:POSitive

Syntax

```
CALibrate:VOLTage:LIMit:POSitive <value>,  
(@<channel>)
```

Description

This command initiates calibration of the positive voltage limit. The value that you enter selects the range that is being calibrated.

NOTE

This command only applies to model N678xA SMU. Refer to Chapter 3 in the Service Guide for a detailed description of the calibration procedure.

Parameters

Name	Type	Range of Values	Default Value
<value>	NRf	The maximum voltage of the range that is being calibrated.	Required parameter
<channel>	NR1	The output channel that is being calibrated.	Required parameter

Example

The following command calibrates the positive voltage limit of channel 1.

```
CAL:VOLT:LIM:POS 20,(@1)
```

See Also

[CALibrate:VOLTage:MEASure](#)

CALibrate:VOLTage:MEASure

Syntax

CALibrate:VOLTage:MEASure <value>, (@<channel>)

Description

This command initiates calibration of the voltage measurement range. The value that you enter selects the range that is being calibrated.

NOTE

Refer to Chapter 3 in the Service Guide for a detailed description of the calibration procedure.

Parameters

Name	Type	Range of Values	Default Value
<value>	NRf	The maximum voltage of the range that is being calibrated.	Required parameter
<channel>	NR1	The output channel that is being calibrated.	Required parameter

Example

The following command calibrates the voltage measurement range of channel 1.

```
CAL:VOLT:MEAS 51, (@1)
```

See Also

[CALibrate:VOLTage\[:LEVel\]](#)

[CALibrate:VOLTage:CMRR](#)

CALibrate:VOLTage:MEASure:AUXiliary

Syntax

CALibrate:VOLTage:MEASure:AUXiliary (@<channel>)

Description

This command initiates calibration of the auxiliary voltage measurement input.

NOTE

This command only applies to model N6781A. Refer to Chapter 3 in the Service Guide for a detailed description of the calibration procedure.

Parameters

Name	Type	Range of Values	Default Value
<channel>	NR1	The output channel that is being calibrated.	Required parameter

Example

The following command calibrates the auxiliary voltage measurement input of channel 1.

```
CAL:VOLT:MEAS:AUX (@1)
```

Common Commands Introduction

Common commands generally control overall instrument functions, such as reset, status, and synchronization. All common commands consist of a three-letter mnemonic preceded by an asterisk: *RST *IDN? *SRE 8.

SCPI Command	Description
*CLS	Clear status
*ESE <NRf>	Standard event status enable
*ESR?	Return event status register
*IDN?	Return instrument identification
*LRN	Returns a sequence of SCPI commands
*OPC	Enable "operation complete" bit in ESR
*OPT?	Return option number
*RCL <NRf>	Recalls a saved instrument state
*RDT?	Return output channel descriptions
*RST	Reset
*SAV <NRf>	Saves an instrument state
*SRE <NRf>	Set service request enable register
*STB?	Return status byte
*TRG	Trigger
*TST?	Performs self-test, then returns result
*WAI	Pauses additional command processing until all device commands are done

CLS*Syntax**

*CLS

Description

This command causes the following actions on the status system:

Clears the Standard Event Status, Operation Status Event, and Questionable Status Event registers.

Clears the Status Byte and the Error Queue.

If *CLS immediately follows a program message terminator (<NL>), then the output queue and the MAV bit are also cleared.

NOTE

For more information on the SCPI Status System, see the [Status System diagram](#)

Example

The following command clears the event register bits.

```
*CLS
```

ESE*Syntax**

*ESE <value>

*ESE?

Description

This command programs the Standard Event Status Enable register bits. The programming determines which events of the Standard Event Status Event register (see [*ESR?](#)) are allowed to set the ESB (Event Summary Bit) of the Status Byte register. A 1 in the bit position enables the corresponding event.

The query reads the enable register and returns a decimal value which corresponds to the binary-weighted sum of all bits set in the register.

NOTE

For more information on the SCPI Status System, see the [Status System diagram](#)

Parameters

Name	Type	Range of Values	Default Value
<value>	NRf	A decimal value which corresponds to the binary-weighted sum of the bits in the register (see table below).	Required parameter.

For example, to enable bit 2 (decimal value = 4), bit 3 (decimal value = 8), and bit 7 (decimal value = 128), the corresponding decimal value would be 140 (4 + 8 + 128).

Remarks

The following table lists the bit definitions for the Standard Event Register.

Bit Number	Decimal Value	Definition
0 Operation Complete	1	All commands prior to and including *OPC have been executed.
1 Not Used	Not Used	0 is returned.
2 Query Error	4	The instrument tried to read the output buffer but it was empty. Or, a new command line was received before a previous query has been read. Or, both the input and output buffers are full.
3 Device-Dependent Error	8	A self-test or calibration error occurred. For a complete listing of the error messages, see SCPI Error Messages .

Bit Number	Decimal Value	Definition
4 Execution Error	16	An execution error occurred (an error in the -200 range has been generated).
5 Command Error	32	A command syntax error occurred (an error in the -100 range has been generated).
6 Not Used	Not Used	0 is returned.
7 Power On	128	Power has been turned off and on since the last time the event register was read or cleared.

All of the enabled events of the Standard Event Status Event Register are logically ORed to cause the Event Summary Bit (ESB) of the Status Byte Register to be set.

The [*CLS](#) (clear status) command will not clear the enable register but it does clear all bits in the event register.

A [*STATUS:PRESet](#) command does not clear the bits in the Status Byte register.

Return Format

<NR1>

The value returned is the binary-weighted sum of all bits set in the register. For example, if bit 3 (decimal value = 8) and bit 7 (decimal value = 128) are enabled, the query command will return 136.

Example

The following command enables bit 4 (decimal value = 16) in the enable register.

```
*ESE 16
```

The following query returns which bits are enabled in the register.

```
*ESE?
```

Typical Response: +16

See Also

[*ESR?](#)

ESR?*Syntax**

*ESR?

Description

This query returns the value of the *Event* register of the Standard Event Status group. The Event register is a read-only register, which stores (latches) all standard events. Reading the Standard Event Status *Event* register clears it.

NOTE

For more information on the SCPI Status System, see the [Status System diagram](#)

Remarks

The following table lists the bit definitions for the Standard Event Register.

Bit Number	Decimal Value	Definition
0 Operation Complete	1	All commands prior to and including *OPC have been executed.
1 Not Used	Not Used	0 is returned.
2 Query Error	4	The instrument tried to read the output buffer but it was empty. Or, a new command line was received before a previous query has been read. Or, both the input and output buffers are full.
3 Device-Dependent Error	8	A self-test or calibration error occurred. For a complete listing of the error messages, see SCPI Error Messages .
4 Execution Error	16	An execution error occurred (an error in the -200 range has been generated).
5 Command Error	32	A command syntax error occurred (an error in the -100 range has been generated).
6 Not Used	Not Used	0 is returned.
7 Power On	128	Power has been turned off and on since the last time the event register was read or cleared.

To be reported to the Standard Event Register, the corresponding bits in the event register must be enabled using the [*ESE](#) command.

Once a bit is set, it remains set until cleared by reading the event register or the [*CLS](#) (clear status) command.

Return Format

<NR1>

The value returned is the binary-weighted sum of all bits set in the register. For example, if bit 3 (decimal value = 8) and bit 7 (decimal value = 128) are enabled, the query command will return 136.

Example

The following command reads the event register (bits 3 and 4 are set).

```
*ESR?
```

Typical Response: +24

See Also

[*ESE](#)

*IDN?

Syntax

*IDN?

Description

This command reads the instrument's (mainframe) identification string which contains four comma-separated fields. The first field is the manufacturer's name, the second field is the instrument model number, the third field is the serial number, and the fourth field is the firmware revision.

Agilent Technologies	Manufacturer
N67xxX	Mainframe model number
MYxxxxxxx	Mainframe serial number if available, or zero
X.xx.xx	Revision levels of firmware

Return Format

<AARD>

The command returns an arbitrary ASCII string with four comma-separated fields. To read the string into your computer, be sure to dimension a string variable with at least 50 characters.

Example

The following query returns the instrument's identification string.

```
*IDN?
```

Typical Response:

```
AGILENT TECHNOLOGIES,N6700B,MY00123456,B.00.00
```

LRN?*Syntax**

```
*LRN?
```

Description

This command returns a sequence of SCPI commands that can later be used to put the power system in the same state that it was in when the *LRN? query was sent. The scope of the returned settings is the same as for the *SAV and *RCL commands.

Return Format

```
<AARD>
```

The command returns an arbitrary ASCII string with semicolon-separated fields. To read the string into your computer, be sure to dimension a string variable with at least 2500 characters.

Example

The following query returns the present state of the instrument.

```
*LRN?
```

Typical Response:

```
*rst::curr 8.000000e-02,(@1)::outp:prot:del
2.000000e-02,(@1)::curr:trig 8.000000e-
02,(@1)::outp:del:fall
0.000000e+00,(@1)::outp:del:rise
0.000000e+00,(@1)::pow:lim 1.000000e+02,(@1)::volt
2.000000e-02,(@1)::volt:prot
5.500000e+01,(@1)::volt:slew
9.900000e+37,(@1)::volt:trig 2.000000e-
02,(@1)::volt:mode fix,(@1)::volt:rang
5.100000e+01,(@1)::curr:mode fix,(@1)::curr:rang
1.020000e+01,(@1)::sens:volt:rang
5.100000e+01,(@1)::sens:curr:rang
1.020000e+01,(@1)::trig:tran:sour
bus,(@1)::init:cont:tran 0,(@1)::curr:prot
0,(@1)::outp 0,(@1)::step:tout
0,(@1)::outp:prot:coup 0::dig:data 0::sens:func
"volt",(@1)::sens:swe:offs:poin
0,(@1)::sens:swe:poin 1024,(@1)::sens:swe:tint
2.048000e-05,(@1)::sens:wind:type
rect,(@1)::trig:acq:sour bus,(@1)::outp
0,(@1)::curr 8.000000e-02,(@2)::outp:prot:del
2.000000e-02,(@2)::curr:trig 8.000000e-
02,(@2)::outp:del:fall
0.000000e+00,(@2)::outp:del:rise...
```

*OPC

Syntax

*OPC

*OPC?

Description

The command is mainly used for program synchronization. It causes the instrument to set the OPC bit (bit 0) of the Standard Event Status register when the instrument has completed all pending operations sent before *OPC. Pending operations are complete when:

1. All commands sent before *OPC, including paralleled commands, have been completed. Most commands are sequential and are completed before the next command is executed. Commands that affect output voltage, current, or state, relays, and trigger actions are executed in parallel with subsequent commands. *OPC provides notification that all parallel commands have completed.
2. All triggered actions are completed.

The query returns 1 to the output buffer.

NOTE

For more information on the SCPI Status System, see the [Status System diagram](#)

Remarks

*OPC does not prevent processing of subsequent commands, but the OPC bit will not be set until all pending operations are completed.

*OPC? causes the instrument to place a 1 in the output buffer when all pending operations are completed. *OPC? does not suspend processing of commands.

Return Format

<NR1>

Returns 1 to the output buffer.

Example

The following command sets the operation complete bit.

```
*OPC
```

The following command waits until the completion of the current command and then sends 1 to the output buffer.

```
*OPC?
```

OPT?*Syntax**

*OPT?

Description

This query requests the mainframe to identify any installed options.

Remarks

A 0 indicates no options are installed.

Return Format

<CRD>

The option number.

Example

The following command returns the option number.

```
*OPT?
```

Typical Response: +0

*RCL

Syntax

```
*RCL 0 | 1
```

Description

This command restores the instrument to a state that was previously stored in memory locations 0 through 1 with the *SAV command. All instrument states are recalled except for the following:

The trigger system is set to the Idle state by an implied ABORT command (this cancels any uncompleted trigger actions).

Calibration is disabled by setting CALibration:STATE to OFF.

All list settings are set to their *RST values.

Remarks

The device state stored in location 0 is automatically recalled at power turn-on when the Output Power-On state is set to RCL 0.

You cannot recall the instrument state from a storage location that is empty or was deleted. You can only recall a state from a location that contains a previously stored state.

A Factory Reset (*RST command) does not affect the configurations stored in memory. Once a state is stored, it remains until it is overwritten or specifically deleted.

Example

The following command recalls the instrument state previously stored in location 1.

```
*RCL 1
```

See Also

[*SAV](#)

[*RST](#)

RDT?*Syntax**

```
*RDT?
```

Description

This query returns a description of all the power modules (channels) installed in a mainframe. Semicolons separate multiple channel descriptions.

CHAN<c>:description <c> refers to the channel number.
Description returns the model number of the power modules.

Return Format

```
<AARD>
```

The command returns an arbitrary ASCII string with up to four semicolon-separated fields. To read the string into your computer, be sure to dimension a string variable with at least 50 characters.

Example

The following query identifies the mainframe's installed power modules.

```
*RDT?
```

Typical Response: CHAN1:N6751A;CHAN2:N6752A

*RST

Syntax

```
*RST
```

Description

This command resets the volatile memory of the instrument to a factory-defined state. Refer to [Factory Reset State](#) for a complete listing of the instrument's factory configuration.

Remarks

*RST also forces the ABORT:ACQuire and ABORT:TRANsient commands. This cancels any measurement or output trigger actions presently in process, and resets the two WTG bits in the Status Operation Condition register.

Example

The following command resets the instrument.

```
*RST
```

See Also

[ABORT:ACQuire](#)

[ABORT:TRANsient](#)

SAV*Syntax**

```
*SAV 0 | 1
```

Description

This command stores the present state of the instrument to the specified location in non-volatile memory. Up to 2 states can be stored - in locations 0 and 1. Any state previously stored in the same location will be overwritten. Use the [*RCL](#) command to retrieve instrument states. Refer to [Factory Reset State](#) for a list of instrument settings that can be saved.

CAUTION

This command causes a write cycle to nonvolatile memory. Nonvolatile memory has a finite maximum number of write cycles. Programs that repeatedly cause write cycles to nonvolatile memory can eventually exceed the maximum number of write cycles and cause the memory to fail.

Remarks

If a particular state is desired at power-on, it should be stored in location 0. It will then be automatically recalled at power turn-on if the Output Power-On state is set to RCL0.

List data and the calibration state is **NOT** saved as part of the *SAV operation. This means that all list data that is sent to the instrument will be lost when the instrument is turned off.

Data saved in non-volatile memory, described in the Non-volatile Factory Settings, is not affected by the *SAV command.

A Factory Reset ([*RST](#) command) does not affect the configurations stored in memory. Once a state is stored, it remains until it is overwritten or specifically deleted.

Example

The following command stores the current instrument state in location 1.

```
*SAV 1
```

See Also

[*RCL](#)

[*RST](#)

SRE*Syntax**

*SRE <value>

*SRE?

Description

This command sets the value of the Service Request Enable register. This register determines which bits from the Status Byte register are summed to set the Master Status Summary (MSS) bit and the Request for Service (RQS) summary bit. A 1 in the bit position enables the corresponding event.

The query reads the enable register and returns a decimal value which corresponds to the binary-weighted sum of all bits set in the register.

NOTE

For more information on the SCPI Status System, see the [Status System diagram](#)

Parameters

Name	Type	Range of Values	Default Value
<value>	NRf	A decimal value which corresponds to the binary-weighted sum of the bits in the register (see table below).	Required parameter.

For example, to enable bit 1 (decimal value = 2), bit 3 (decimal value = 8), and bit 6 (decimal value = 64), the corresponding decimal value would be 74 (2 + 8 + 64).

Remarks

The following table lists the bit definitions for the Status Byte Register.

Bit Number	Decimal Value	Definition
0 Not Used	Not Used	0 is returned.
1 Not Used	Not Used	0 is returned.
2 Error Queue not empty	4	One or more errors have been stored in the Error Queue (see SYSTEM:ERRor? command).
3 Questionable Status summary	8	One or more bits are set in the Questionable Data Register (bits must be enabled, see STATus:QUEStionable:ENABle command).
4 Message Available	16	Data is available in the instrument's output buffer.

Bit Number	Decimal Value	Definition
5 Event Status Byte summary	32	One or more bits are set in the Standard Event Register (bits must be enabled, see *ESE command).
6 Master Status summary (Request for Service)	64	One or more bits are set in the Status Byte Register (bits must be enabled, see *SRE command). Also used to indicate a request for service.
7 Operation Status summary	128	One or more bits are set in the Standard Operation Register (bits must be enabled, see *STATus:OPERation:ENABle command).

When the controller conducts a serial poll in response to SRQ, the RQS bit is cleared, but the MSS bit is not. When *SRE is cleared (by programming it with 0), the power system cannot generate an SRQ to the controller.

The [*CLS](#) (clear status) command will not clear the enable register but it does clear all bits in the event register.

A [*STATus:PRESet](#) command does not clear the bits in the Status Byte register.

Return Format

<NR1>

The value returned is the binary-weighted sum of all bits set in the register. For example, if bit 3 (decimal value = 8) and bit 7 (decimal value = 128) are enabled, the query command will return "+136".

Examples

The following command enables bit 4 (decimal value = 16) in the enable register.

```
*SRE 16
```

The following query returns which bits are enabled in the register.

```
*SRE?
```

Typical Response: +16

See Also

[*STB?](#)

STB?*Syntax**

*STB?

Description

This query reads the Status Byte register, which contains the status summary bits and the Output Queue MAV bit. The Status Byte is a read-only register and the bits are *not* cleared when it is read.

NOTE

For more information on the SCPI Status System, see the [Status System diagram](#)

Remarks

The following table lists the bit definitions for the Status Byte Register.

Bit Number	Decimal Value	Definition
0 Not Used	Not Used	0 is returned.
1 Not Used	Not Used	0 is returned.
2 Error Queue not empty	4	One or more errors have been stored in the Error Queue (see SYSTem:ERRor? command).
3 Questionable Status summary	8	One or more bits are set in the Questionable Data Register (bits must be enabled, see STATus:QUEStionable:ENABle command).
4 Message Available	16	Data is available in the instrument's output buffer.
5 Event Status Byte summary	32	One or more bits are set in the Standard Event Register (bits must be enabled, see *ESE command).
6 Master Status summary (Request for Service)	64	One or more bits are set in the Status Byte Register (bits must be enabled, see *SRE command). Also used to indicate a request for service.
7 Operation Status summary	128	One or more bits are set in the Standard Operation Register (bits must be enabled, see STATus:OPERation:ENABle command).

The input summary bits are cleared when the appropriate event registers are read. The MAV bit is cleared at power-on, by [*CLS](#), or when there is no more response data available.

A serial poll also returns the value of the Status Byte register, except that bit 6 returns Request for Service (RQS) instead of Master Status Summary (MSS). A serial poll clears RQS, but not MSS. When MSS is set, it indicates that the instrument has one or more reasons for requesting service.

Return Format

<NR1>

The value returned is the binary-weighted sum of all bits set in the register. For example, if bit 1 (decimal value = 2) and bit 4 (decimal value = 16) are set (and the corresponding bits are enabled), this command will return 18.

Example

The following command reads the condition register (bits 3 and 4 are set).

```
*STB?
```

Typical Response: +24

See Also

[*SRE](#)

*TRG

Syntax

*TRG

Description

This common command generates a trigger when the trigger subsystem has BUS selected as its source. The command has the same affect as the Group Execute Trigger (<GET>) command.

Example

The following command generates a trigger.

```
*TRG
```

See Also

[ABORt:ACQuire](#)

[ABORt:TRANsient](#)

[INITiate\[:IMMediate\]:ACQuire](#)

[INITiate\[:IMMediate\]:TRANsient](#)

*TST?

Syntax

*TST?

Description

This query causes the instrument to do a self-test and report any errors. A 0 indicates the instrument passed self-test. If all tests pass, you can have a high confidence that the instrument is operational.

Remarks

If one or more tests fail, a 1 is returned and an error is stored in the error queue. For a complete listing of the error messages related to self-test failures, see [SCPI Error Messages](#).

If one or more tests fail, see the Service Guide for instructions on returning the instrument to Agilent for service.

*TST? also forces an *RST command.

Return Format

<NR1>

The command returns 0 (all tests passed) or 1 (one or more tests failed).

Example

The following command performs a self-test and returns a pass/fail indication.

```
*TST?
```

Typical Response: +0

*WAI

Syntax

```
*WAI
```

Description

This command instructs the instrument not to process any further commands until all pending operations are completed. Pending operations are as defined under the [*OPC](#) command.

Remarks

*WAI can be aborted only by sending the instrument a [Device Clear](#) command.

Example

The following command waits for pending operations to complete.

```
*WAI
```

See Also

[*OPC](#)

DISPlay Commands Introduction

The Display commands let you control the front panel display.

SCPI Command	Description
DISPlay	
[:WINDow]	
:CHANnel <channel>	Selects the channel in 1-channel meter view
:VIEW METER1 METER4	Selects 1-channel or 4-channel meter view

DISPlay[:WINDow]:VIEW**Syntax**

```
DISPlay[:WINDow]:VIEW <view>
```

```
DISPlay[:WINDow]:VIEW?
```

Description

This command selects the output channel view of the front panel display. METER1 displays one output channel. METER4 displays all output channels up to a maximum of four.

Parameters

Name	Type	Range of Values	Default Value
<view>	CPD	METER1 METER4	METER1

Return Format

```
<CRD>
```

The query command returns METER1 or METER4.

Example

The following command sets the front panel to display only one output channel.

```
DISP:VIEW METER1
```

The following query returns the channel view of the front-panel display.

```
DISP:VIEW?
```

Typical Response: METER1

DISPlay[:WINDow]:CHANnel

Syntax

```
DISPlay[:WINDow]:CHANnel <channel>
```

```
DISPlay[:WINDow]:CHANnel?
```

Description

This command selects the output channel to display on the front panel in single-channel view (METER1).

Parameters

Name	Type	Range of Values	Default Value
<channel>	NR1	1 2 3 4	1

Return Format

```
<CRD>
```

The query command returns the channel number that is presently displayed.

Example

The following command sets the front panel to display channel 4.

```
DISP:CHAN 4
```

The following query returns the channel that is presently displayed.

```
DISP:CHAN?
```

Typical Response: 4

FETCh Subsystem Introduction

Fetch commands return measurement data that has been previously acquired. If you take a voltage measurement, you can fetch only voltage data. If you take a current measurement, you can fetch only current data. Use Fetch commands to return measurement data that has been synchronized with a triggered event.

SCPI Command	Description
FETCh	(Fetch commands only on N676xA, N678xA SMU and Option 054)
[:SCALar]	
:CURRent	
[:DC]? (@chanlist)	Returns the average current
:ACDC? (@chanlist)	Returns the total rms current (AC + DC)
:HIGH? (@chanlist)	Returns the high level of a current pulse
:LOW? (@chanlist)	Returns the low level of a current pulse
:MAXimum? (@chanlist)	Returns the maximum current
:MINimum? (@chanlist)	Returns the minimum current
:POWer	
[:DC]? (@chanlist)	Returns the average output power
:VOLTage	
[:DC]? (@chanlist)	Returns the average voltage
:ACDC? (@chanlist)	Returns the total rms voltage (AC + DC)
:HIGH? (@chanlist)	Returns the high level of a voltage pulse
:LOW? (@chanlist)	Returns the low level of a voltage pulse
:MAXimum? (@chanlist)	Returns the maximum voltage
:MINimum? (@chanlist)	Returns the minimum voltage
:ARRay	
:CURRent [:DC]? (@chanlist)	Returns the instantaneous output current
:POWer [:DC]? (@chanlist)	Returns the instantaneous output power
:VOLTage [:DC]? (@chanlist)	Returns the instantaneous output voltage
:ELOG <NR1>, (@chanlist)	Returns the most recent external data log records

FETCh[:SCALar]:CURRent[:DC]?**Syntax**

```
FETCh[:SCALar]:CURRent[:DC]? (@<chanlist>)
```

Description

This query returns the average output current in amperes. The data returned is the result of the last measurement command or triggered acquisition. The data is valid until the next MEASure or INITiate command occurs. For triggered data acquisitions, you must enable current measurements (see [SENSe:FUNCTION:CURRent](#)).

NOTE

This command is used only with models N676xA, N678xA SMU, or models that have Option 054 (High Speed Test Extensions).

Parameters

Name	Type	Range of Values	Default Value
<chanlist>	Numeric	One or more channels. (@2) - channel 2 (@1,4) - channels 1 and 4 (@1:3) - channels 1 through 3.	Required parameter

Remarks

The FETCh query does not perform a new measurement.

The FETCh query allows additional measurement calculations from the same acquired data.

Return Format

```
<NR3>
```

The reading is in the form +n.nnnnnnE+nn for each channel specified. Multiple responses are separated by commas.

Example

The following query returns the current measured on channel 1.

```
FETCh:CURR? (@1)
```

Typical Response: +1.000000E+01

See Also

[FETCh\[:SCALar\]:VOLTage\[:DC\]?](#)

FETCh[:SCALar]:CURRent:ACDC?**Syntax**

FETCh[:SCALar]:CURRent:ACDC? (@<chanlist>)

Description

This query returns the total RMS current (AC + DC) in amperes. The data returned is the result of the last measurement command or triggered acquisition. The data is valid until the next MEASure or INITiate command occurs. For triggered data acquisitions, you must enable current measurements (see [SENSe:FUNCTION:CURRent](#)).

NOTE

This command is used only with models N676xA, N678xA SMU, or models that have Option 054 (High Speed Test Extensions).

Parameters

Name	Type	Range of Values	Default Value
<chanlist>	Numeric	One or more channels. (@2) - channel 2 (@1,4) - channels 1 and 4 (@1:3) - channels 1 through 3.	Required parameter

Remarks

The FETCh query does not perform a new measurement.

The FETCh query allows additional measurement calculations from the same acquired data.

Return Format

<NR3>

The reading is in the form +n.nnnnnnE+nn for each channel specified. Multiple responses are separated by commas.

Example

The following query returns the RMS current measured on channel 1.

```
FETCh:CURR:ACDC? (@1)
```

Typical Response: +1.000000E+01

See Also

[FETCh\[:SCALar\]:VOLTage:ACDC?](#)

FETCh[:SCALar]:CURRent:HIGH?

Syntax

```
FETCh[:SCALar]:CURRent:HIGH? (@<chanlist>)
```

Description

This query returns the High level of a current pulse waveform in amperes. The data used by this query calculation is the result of the last measurement command or triggered acquisition. For triggered data acquisitions, you must enable current measurements (see [SENSe:FUNction:CURRent](#)).

The High level calculation generates a histogram of the waveform using 16 bins between the maximum and minimum data points. The bin containing the most data points above the 50% point is the high bin. The average of all the data points in the high bin is returned as the High level. If no high bin contains more than 1.25% of the total number of acquired points, then the maximum data point is returned.

NOTE

This command is used only with models N676xA, N678xA SMU, or models that have Option 054 (High Speed Test Extensions).

Parameters

Name	Type	Range of Values	Default Value
<chanlist>	Numeric	One or more channels. (@2) - channel 2 (@1,4) - channels 1 and 4 (@1:3) - channels 1 through 3.	Required parameter

Remarks

The FETCh query does not perform a new measurement.

The FETCh query allows additional measurement calculations from the same acquired data.

Return Format

```
<NR3>
```

The reading is in the form +n.nnnnnnE+nn for each channel specified. Multiple responses are separated by commas.

Example

The following query returns the high level of the current pulse on channel 1.

```
FETC:CURR:HIGH? (@1)
```

Typical Response: +1.000000E+01

See Also

[FETCh\[:SCALar\]:VOLTage:HIGH?](#)

FETCh[:SCALar]:CURRent:LOW?

Syntax

```
FETCh[:SCALar]:CURRent:LOW? (@<chanlist>)
```

Description

This query returns the Low level of a current pulse waveform in amperes. The data used by this query calculation is the result of the last measurement command or triggered acquisition. For triggered data acquisitions, you must enable current measurements (see [SENSe:FUNcTION:CURRent](#)).

The Low level calculation generates a histogram of the waveform using 16 bins between the maximum and minimum data points. The bin containing the most data points below the 50% point is the low bin. The average of all the data points in the low bin is returned as the Low level. If no low bin contains less than 1.25% of the total number of acquired points, then the minimum data point is returned.

NOTE

This command is used only with models N676xA, N678xA SMU, or models that have Option 054 (High Speed Test Extensions).

Parameters

Name	Type	Range of Values	Default Value
<chanlist>	Numeric	One or more channels. (@2) - channel 2 (@1,4) - channels 1 and 4 (@1:3) - channels 1 through 3.	Required parameter

Remarks

The FETCh query does not perform a new measurement.

The FETCh query allows additional measurement calculations from the same acquired data.

Return Format

```
<NR3>
```

The reading is in the form +n.nnnnnnE+nn for each channel specified. Multiple responses are separated by commas.

Example

The following query returns the low level of the current pulse on channel 1.

```
FETC:CURR:LOW? (@1)
```

Typical Response: +1.000000E+01

See Also

[FETCh\[:SCALar\]:VOLTage:LOW?](#)

FETCh[:SCALar]:CURRent:MAXimum?

Syntax

FETCh[:SCALar]:CURRent:MAXimum? (@<chanlist>)

Description

This query returns the maximum value in amperes. The value is from the last measurement command or triggered acquisition. For triggered data acquisitions, you must enable current measurements (see [SENSe:FUNCTion:CURRent](#)).

NOTE

This command is used only with models N676xA, N678xA SMU, or models that have Option 054 (High Speed Test Extensions).

Parameters

Name	Type	Range of Values	Default Value
<chanlist>	Numeric	One or more channels. (@2) - channel 2 (@1,4) - channels 1 and 4 (@1:3) - channels 1 through 3.	Required parameter

Remarks

The FETCh query does not perform a new measurement.

The FETCh query allows additional measurement calculations from the same acquired data.

Return Format

<NR3>

The reading is in the form +n.nnnnnnE+nn for each channel specified. Multiple responses are separated by commas.

Example

The following query returns the maximum current value on channel 1.

```
FETC:CURR:MAX? (@1)
```

Typical Response: +1.000000E+01

See Also

[FETCh\[:SCALar\]:VOLTage:MAX?](#)

FETCh[:SCALar]:CURRent:MINimum?**Syntax**

FETCh[:SCALar]:CURRent:MINimum? (@<chanlist>)

Description

This query returns the minimum value in amperes. The value is from the last measurement command or triggered acquisition. For triggered data acquisitions, you must enable current measurements (see [SENSe:FUNCTion:CURRent](#)).

NOTE

This command is used only with models N676xA, N678xA SMU, or models that have Option 054 (High Speed Test Extensions).

Parameters

Name	Type	Range of Values	Default Value
<chanlist>	Numeric	One or more channels. (@2) - channel 2 (@1,4) - channels 1 and 4 (@1:3) - channels 1 through 3.	Required parameter

Remarks

The FETCh query does not perform a new measurement.

The FETCh query allows additional measurement calculations from the same acquired data.

Return Format

<NR3>

The reading is in the form +n.nnnnnnE+nn for each channel specified. Multiple responses are separated by commas.

Example

The following query returns the minimum current value on channel 1.

```
FETC:CURR:MIN? (@1)
```

Typical Response: +1.000000E+01

See Also

[FETCh\[:SCALar\]:VOLTage:MIN?](#)

FETCh[:SCALar]:POWer[:DC]?

Syntax

FETCh[:SCALar]:POWer[:DC]? (@<chanlist>)

Description

This query returns the average output power in watts. The data returned is the result of the last measurement command or triggered acquisition. The data is valid until the next MEASure or INITiate command occurs. For triggered data acquisitions, you must enable BOTH current and voltage measurements (see [SENSe:FUNcTion:CURRent](#) and [SENSe:FUNcTion:VOLTagE](#)).

NOTE

This command only applies to models N676xA and N678xA SMU. These models have simultaneous voltage and current measurement capability.

Parameters

Name	Type	Range of Values	Default Value
<chanlist>	Numeric	One or more channels. (@2) - channel 2 (@1,4) - channels 1 and 4 (@1:3) - channels 1 through 3.	Required parameter

Remarks

The FETCh query does not perform a new measurement.

The FETCh query allows additional measurement calculations from the same acquired data.

Return Format

<NR3>

The reading is in the form +n.nnnnnnE+nn for each channel specified. Multiple responses are separated by commas.

Example

The following query returns the powere measured on channel 1.

```
FETC:POW? (@1)
```

Typical Response: +1.000000E+01

See Also

[FETCh:ARRay:POWer\[:DC\]?](#)

FETCh[:SCALar]:VOLTage[:DC]?**Syntax**

FETCh[:SCALar]:VOLTage[:DC]? (@<chanlist>)

Description

This query returns the average output voltage in volts. The data returned is the result of the last measurement command or triggered acquisition. The data is valid until the next MEASure or INITiate command occurs. For triggered data acquisitions, you must enable voltage measurements (see [SENSe:FUNCTION:VOLTage](#)).

NOTE

This command is used only with models N676xA, N678xA SMU, or models that have Option 054 (High Speed Test Extensions).

Parameters

Name	Type	Range of Values	Default Value
<chanlist>	Numeric	One or more channels. (@2) - channel 2 (@1,4) - channels 1 and 4 (@1:3) - channels 1 through 3.	Required parameter

Remarks

The FETCh query does not perform a new measurement.

The FETCh query allows additional measurement calculations from the same acquired data.

Return Format

<NR3>

The reading is in the form +n.nnnnnnE+nn for each channel specified. Multiple responses are separated by commas.

Example

The following query returns the voltage measured on channel 1.

```
FETCh:VOLT? (@1)
```

Typical Response: +5.000000E+01

See Also

[FETCh\[:SCALar\]:CURRent\[:DC\]?](#)

FETCh[:SCALar]:VOLTage:ACDC?**Syntax**

```
FETCh[:SCALar]:VOLTage:ACDC? (@<chanlist>)
```

Description

This query returns the total RMS voltage (AC + DC) in volts. The data returned is the result of the last measurement command or triggered acquisition. The data is valid until the next MEASure or INITiate command occurs. For triggered data acquisitions, you must enable voltage measurements (see [SENSe:FUNCTION:VOLTage](#)).

NOTE

This command is used only with models N676xA, N678xA SMU, or models that have Option 054 (High Speed Test Extensions).

Parameters

Name	Type	Range of Values	Default Value
<chanlist>	Numeric	One or more channels. (@2) - channel 2 (@1,4) - channels 1 and 4 (@1:3) - channels 1 through 3.	Required parameter

Remarks

The FETCh query does not perform a new measurement.

The FETCh query allows additional measurement calculations from the same acquired data.

Return Format

```
<NR3>
```

The reading is in the form +n.nnnnnnE+nn for each channel specified. Multiple responses are separated by commas.

Example

The following query returns the RMS voltage measured on channel 1.

```
FETCh:VOLT:ACDC? (@1)
```

Typical Response: +5.000000E+01

See Also

[FETCh\[:SCALar\]:CURRent:ACDC?](#)

FETCh[:SCALar]:VOLTage:HIGH?

Syntax

FETCh[:SCALar]:VOLTage:HIGH? (@<chanlist>)

Description

This query returns the High level of a voltage pulse waveform in volts. The data used by this query calculation is the result of the last measurement command or triggered acquisition. For triggered data acquisitions, you must enable voltage measurements (see [SENSe:FUNCTion:VOLTage](#)).

The High level calculation generates a histogram of the waveform using 16 bins between the maximum and minimum data points. The bin containing the most data points above the 50% point is the high bin. The average of all the data points in the high bin is returned as the High level. If no high bin contains more than 1.25% of the total number of acquired points, then the maximum data point is returned.

NOTE

This command is used only with models N676xA, N678xA SMU, or models that have Option 054 (High Speed Test Extensions).

Parameters

Name	Type	Range of Values	Default Value
<chanlist>	Numeric	One or more channels. (@2) - channel 2 (@1,4) - channels 1 and 4 (@1:3) - channels 1 through 3.	Required parameter

Remarks

The FETCh query does not perform a new measurement.

The FETCh query allows additional measurement calculations from the same acquired data.

Return Format

<NR3>

The reading is in the form +n.nnnnnnE+nn for each channel specified. Multiple responses are separated by commas.

Example

The following query returns the high level of the voltage pulse on channel 1.

```
FETC:VOLT:HIGH? (@1)
```

Typical Response: +5.000000E+01

See Also

[FETCh\[:SCALar\]:CURRent:HIGH?](#)

FETCh[:SCALar]:VOLTage:LOW?

Syntax

FETCh[:SCALar]:VOLTage:LOW? (@<chanlist>)

Description

This query returns the Low level of a voltage pulse waveform in volts. The data used by this query calculation is the result of the last measurement command or triggered acquisition. For triggered data acquisitions, you must enable voltage measurements (see [SENSe:FUNCTion:VOLTage](#)).

The Low level calculation generates a histogram of the waveform using 16 bins between the maximum and minimum data points. The bin containing the most data points below the 50% point is the low bin. The average of all the data points in the low bin is returned as the Low level. If no low bin contains less than 1.25% of the total number of acquired points, then the minimum data point is returned.

NOTE

This command is used only with models N676xA, N678xA SMU, or models that have Option 054 (High Speed Test Extensions).

Parameters

Name	Type	Range of Values	Default Value
<chanlist>	Numeric	One or more channels. (@2) - channel 2 (@1,4) - channels 1 and 4 (@1:3) - channels 1 through 3.	Required parameter

Remarks

The FETCh query does not perform a new measurement.

The FETCh query allows additional measurement calculations from the same acquired data.

Return Format

<NR3>

The reading is in the form +n.nnnnnnE+nn for each channel specified. Multiple responses are separated by commas.

Example

The following query returns the low level of the voltage pulse on channel 1.

```
FETC:VOLT:LOW? (@1)
```

Typical Response: +5.000000E+01

See Also

[FETCh\[:SCALar\]:CURRent:LOW?](#)

FETCh[:SCALar]:VOLTage:MAXimum?

Syntax

FETCh[:SCALar]:VOLTage:MAXimum? (@<chanlist>)

Description

This query returns the maximum value in volts. The value is from the last measurement command or triggered acquisition. For triggered data acquisitions, you must enable voltage measurements (see [SENSe:FUNCTion:VOLTage](#)).

NOTE

This command is used only with models N676xA, N678xA SMU, or models that have Option 054 (High Speed Test Extensions).

Parameters

Name	Type	Range of Values	Default Value
<chanlist>	Numeric	One or more channels. (@2) - channel 2 (@1,4) - channels 1 and 4 (@1:3) - channels 1 through 3.	Required parameter

Remarks

The FETCh query does not perform a new measurement.

The FETCh query allows additional measurement calculations from the same acquired data.

Return Format

<NR3>

The reading is in the form +n.nnnnnnE+nn for each channel specified. Multiple responses are separated by commas.

Example

The following query returns the maximum voltage value on channel 1.

```
FETC:VOLT:MAX? (@1)
```

Typical Response: +1.000000E+01

See Also

[FETCh\[:SCALar\]:CURRent:MAX?](#)

FETCh[:SCALar]:VOLTage:MINimum?

Syntax

FETCh[:SCALar]:VOLTage:MINimum? (@<chanlist>)

Description

This query returns the minimum value in volts. The value is from the last measurement command or triggered acquisition. For triggered data acquisitions, you must enable voltage measurements (see [SENSe:FUNCTion:VOLTage](#)).

NOTE

This command is used only with models N676xA, N678xA SMU, or models that have Option 054 (High Speed Test Extensions).

Parameters

Name	Type	Range of Values	Default Value
<chanlist>	Numeric	One or more channels. (@2) - channel 2 (@1,4) - channels 1 and 4 (@1:3) - channels 1 through 3.	Required parameter

Remarks

The FETCh query does not perform a new measurement.

The FETCh query allows additional measurement calculations from the same acquired data.

Return Format

<NR3>

The reading is in the form +n.nnnnnnE+nn for each channel specified. Multiple responses are separated by commas.

Example

The following query returns the minimum voltage value on channel 1.

```
FETC:VOLT:MIN? (@1)
```

Typical Response: +1.000000E+01

See Also

[FETCh\[:SCALar\]:CURRent:MIN?](#)

FETCh:ARRAy:CURRent[:DC]?

Syntax

FETCh:ARRAy:CURRent[:DC]? (@<chanlist>)

Description

This query returns an array containing the digitized output current in amperes. The data returned by the FETCh command is the result of the last measurement command or triggered acquisition. The data is valid until the next MEASure or INITiate command occurs. For triggered data acquisitions, you must enable voltage measurements (see [SENSe:FUNCTion:VOLTage](#)).

The output current is digitized whenever a measurement command is sent or an acquisition trigger occurs. The sampling rate is set by SENSe:SWEep:TINterval. The position of the trigger relative to the beginning of the data buffer is determined by SENSe:SWEep:OFFSet. The number of points returned is set by SENSe:SWEep:POINts.

NOTE

This command is used only with models N676xA, N678xA SMU, or models that have Option 054 (High Speed Test Extensions).

Parameters

Name	Type	Range of Values	Default Value
<chanlist>	Numeric	One or more channels. (@2) - channel 2 (@1,4) - channels 1 and 4 (@1:3) - channels 1 through 3.	Required parameter

Remarks

The FETCh query does not perform a new measurement.

The FETCh query allows additional measurement calculations from the same acquired data.

Return Format

The return format depends on the settings of the FORMat:BORDER and FORMat[:DATA] commands. When the data format is set to ASCII, returned values are comma separated. Only one channel can be queried when the format is ASCII. When the data format is set to REAL, data is returned as single precision floating point numbers in definite length arbitrary block response format. Each block contains all the records for one of the channels given in the <chanlist> parameter. If multiple channels are given, then each definite length arbitrary block of data is separated by a comma.

<NR3> [,<NR3>]
or
<block> [,<block>]

Example

The following query returns the current measured on channel 1.

```
FETC:ARR:CURR? (@1)
```

See Also

[FETCh:ARRay:VOLTagE\[:DC\]?](#)

[SENSe:SWEp:TINterval](#)

[SENSe:SWEp:OFFset:POINts](#)

[SENSe:SWEp:POINts](#)

FETCh:ARRay:POWer[:DC]?**Syntax**

FETCh:ARRay:POWer[:DC]? (@<chanlist>)

Description

This query returns an array containing the digitized output power in watts. The data returned by the FETCh command is the result of the last measurement command or triggered acquisition. The data is valid until the next MEASure or INITiate command occurs. For triggered data acquisitions, you must enable BOTH current and voltage measurements (see [SENSe:FUNCTION:CURRENT](#) and [SENSe:FUNCTION:VOLTage](#)).

The output power is digitized whenever a measurement command is sent or an acquisition trigger occurs. The sampling rate is set by SENSE:SWEEP:TINTERVAL. The position of the trigger relative to the beginning of the data buffer is determined by SENSE:SWEEP:OFFSET. The number of points returned is set by SENSE:SWEEP:POINTS.

NOTE

This command only applies to models N676xA and N678xA SMU. These models have simultaneous voltage and current measurement capability.

Parameters

Name	Type	Range of Values	Default Value
<chanlist>	Numeric	One or more channels. (@2) - channel 2 (@1,4) - channels 1 and 4 (@1:3) - channels 1 through 3.	Required parameter

Remarks

The FETCh query does not perform a new measurement.

The FETCh query allows additional measurement calculations from the same acquired data.

Return Format

The return format depends on the settings of the FORMat:BORDER and FORMat[:DATA] commands. When the data format is set to ASCII, returned values are comma separated. Only one channel can be queried when the format is ASCII. When the data format is set to REAL, data is returned as single precision floating point numbers in definite length arbitrary block response format. Each block contains all the records for one of the channels given in the <chanlist> parameter. If multiple channels are given, then each definite length arbitrary block of data is separated by a comma.

<NR3> [,<NR3>]
or
<block> [,<block>]

Example

The following query returns the power measured on channel 1.

```
FETC:ARR:POW? (@1)
```

See Also

[SENSe:SWEep:TINterval](#)

[SENSe:SWEep:OFFset:POINTs](#)

[SENSe:SWEep:POINTs](#)

FETCh:ARRAy:VOLTage[:DC]?

Syntax

FETCh:ARRAy:VOLTage[:DC]? (@<chanlist>)

Description

This query returns an array containing the digitized output voltage in volts. The data returned by the FETCh command is the result of the last measurement command or triggered acquisition. The data is valid until the next MEASure or INITiate command occurs. For triggered data acquisitions, you must enable voltage measurements (see [SENSe:FUNcTION:VOLTage](#)).

The output voltage is digitized whenever a measurement command is sent or an acquisition trigger occurs. The sampling rate is set by SENSe:SWEep:TINterval. The position of the trigger relative to the beginning of the data buffer is determined by SENSe:SWEep:OFFSet. The number of points returned is set by SENSe:SWEep:POINts.

NOTE

This command is used only with models N676xA, N678xA SMU, or models that have Option 054 (High Speed Test Extensions).

Parameters

Name	Type	Range of Values	Default Value
<chanlist>	Numeric	One or more channels. (@2) - channel 2 (@1,4) - channels 1 and 4 (@1:3) - channels 1 through 3.	Required parameter

Remarks

The FETCh query does not perform a new measurement.

The FETCh query allows additional measurement calculations from the same acquired data.

Return Format

The return format depends on the settings of the FORMat:BORDER and FORMat[:DATA] commands. When the data format is set to ASCII, returned values are comma separated. Only one channel can be queried when the format is ASCII. When the data format is set to REAL, data is returned as single precision floating point numbers in definite length arbitrary block response format. Each block contains all the records for one of the channels given in the <chanlist> parameter. If multiple channels are given, then each definite length arbitrary block of data is separated by a comma.

<NR3> [,<NR3>]

or

<block> [,<block>]

Example

The following query returns the voltage measured on channel 1.

```
FETC:ARR:VOLT? (@1)
```

See Also

[FETCh:ARRay:CURRent\[:DC\]?](#)

[SENSe:SWEp:TINterval](#)

[SENSe:SWEp:OFFset:POINts](#)

[SENSe:SWEp:POINts](#)

FETCh:ELOG?

Syntax

FETCh:ELOG? <maxrecords>, (@<chanlist>)

Description

This query returns external datalog data from the instrument's buffer. The instrument has a buffer for each channel that holds 10 seconds of accumulated data. Data accumulates in the buffer at the rate determined by [SENSe:ELOG:PERiod](#). Data must be read from the buffer periodically to avoid the buffer overflowing. The instrument assumes that there is only one reader of data, so whenever data is read using FETCh:ELOG? then that buffer space is made available in the instrument for storing more acquired data.

Maxrecords is the maximum number of records of external datalog data that the controller will return for each channel. A record is one set of voltage and current readings for one time interval. The exact format of a record depends on which functions have been enabled for external datalog sensing. If all functions are enabled, then one record will contain: Current average,

Current minimum,
Current maximum,
Voltage average,
Voltage minimum,
Voltage maximum,

in that order. If any of these sense functions are not enabled, that data is not part of the returned record. The values are returned as consecutive numbers in the response.

Parameters

Name	Type	Range of Values	Default Value
<chanlist>	Numeric	One or more channels. (@2) - channel 2 (@1,4) - channels 1 and 4 (@1:3) - channels 1 through 3.	Required parameter
<maxrecords>	NR1	1 to 16,384 (for 4 channels)	Required parameter

Return Format

The return format depends on the settings of the FORMat:BORDER and FORMat[:DATA] commands. When the data format is set to ASCII, returned values are comma separated. Only one channel can be queried when the format is ASCII. When the data format is set to REAL, data is returned as single precision floating point numbers in definite length arbitrary block response format. Each block contains all the records for one of the channels given in the <chanlist> parameter. If multiple channels are given, then each definite length arbitrary block of data is separated by a comma.

<NR3> [,<NR3>]
or
<block> [,<block>]

Example

The following query returns 100 data records of channel 1.

```
FETC:ELOG? 100 , @1
```

See Also

[FORMat:BORDER](#)

[FORMat\[:DATA\]](#)

FORMat Commands Introduction

The FORMat commands let you specify the format for transferring measurement data.

SCPI Command	Description
FORMat	
[:DATA] ASCII REAL	Returns data as ASCII or binary
:BORDER NORMAL SWAPPED	Sets the byte order of the external data log data

FORMat[:DATA]

Syntax

FORMat[:DATA] <type>

FORMat[:DATA]?

Description

This command specifies the format of the data returned by queries that can return a block of data.

ASCII Numeric data is transferred as ASCII bytes in <NR1>, <NR2>, or <NR3> format as appropriate. The numbers are separated by commas.

REAL Data is returned in binary IEEE single precision floating point. In this case the 4 bytes of each value can be returned in either big-endian or little-endian byte order, determined by the FORMat:BOReDer setting.

Parameters

Name	Type	Range of Values	Default Value
<type>	CPD	ASCII REAL	ASCII

Remarks

The data format is used when fetching data from SCPI measurements. These include: FETC:ARR:CURR? and FETC:ARR:VOLT?.

Return Format

<CRD>

The query command returns the data format setting.

Examples

The following command sets the data format to ASCII.

```
FORM ASCII
```

The following query returns the data format setting.

```
FORM?
```

Typical Response: ASCII

See Also

[FORMat:BOReDer](#)

FORMat:BORDER

Syntax

FORMat:BORDER <setting>

FORMat:BORDER?

Description

This command specifies how binary data is transferred. This only applies when the FORMat:DATA is set to REAL.

NORMAL Binary data is transferred in normal order. The most significant byte is returned first, and the least significant byte is returned last (big-endian).

SWAPped Binary data is transferred in swapped-byte order. The least significant byte is returned first, and the most significant byte is returned last (little-endian).

Parameters

Name	Type	Range of Values	Default Value
<setting>	CPD	NORMAL SWAPped	NORMAL

Remarks

The byte order is used when fetching data from SCPI measurements. These include: FETC:ARR:CURR? and FETC:ARR:VOLT?.

Return Format

<CRD>

The query command returns the binary byte order setting.

Examples

The following command sets the byte order setting to SWAPped.

```
FORM:BORD SWAP
```

The following query returns the byte order setting.

```
FORM:BORD?
```

Typical Response: SWAP

See Also

[FORMat\[:DATA\]](#)

INITiate Subsystem Introduction

Initiate commands initialize the trigger system. This enables the trigger system to receive triggers.

SCPI Command	Description
INITiate	
[:IMMEDIATE]	(Acquire command only on N676xA, N678xA SMU and Option 054)
:ACQUIRE (@chanlist)	Enables the measurement system to receive triggers
:ELOG (@chanlist)	Enables external data logger measurements
:TRANSIENT (@chanlist)	Enables the output transient system to receive triggers
:CONTINUOUS	
:TRANSIENT <Bool>, (@chanlist)	Enables/disables continuous transient triggers

INITiate[:IMMediate]:ACQuire

Syntax

```
INITiate[:IMMediate]:ACQuire (@<chanlist>)
```

Description

This command enables the measurement trigger system. When a measurement trigger is initiated, an event on a selected trigger source causes the specified triggering action to occur. If the trigger system is not initiated, all triggers are ignored.

NOTE

This command is used only with models N676xA, N678xA SMU, or models that have Option 054 (High Speed Test Extensions).

Parameters

Name	Type	Range of Values	Default Value
<chanlist>	Numeric	One or more channels. (@2) - channel 2 (@1,4) - channels 1 and 4 (@1:3) - channels 1 through 3.	Required parameter

Remarks

It takes a few milliseconds for the instrument to be ready to receive a trigger signal after receiving the INITiate:ACQuire command, and it can take longer if the value of SENSE:SWEep:OFFSet is negative.

If a trigger occurs before the trigger system is ready for it, the trigger will be ignored. The user can test the WTG_meas bit in the operation status register to know when the instrument is ready to receive a trigger after initiating.

Example

The following command initiates the measurement trigger system on channel 1.

```
INIT:ACQ (@1)
```

See Also

[INITiate\[:IMMediate\]:TRANsient](#)

[ABORt:ACQuire](#)

INITiate[:IMMediate]:ELOG

Syntax

```
INITiate[:IMMediate]:ELOG (@<chanlist>)
```

Description

This command initiates an external data log. When the external data log is initiated, an event on a selected external data log trigger source starts the data log. If the external data log is not initiated, all triggers are ignored.

The external data log function is not accessible from the instrument's front panel. All external data log functions are controlled using SCPI commands.

Parameters

Name	Type	Range of Values	Default Value
<chanlist>	Numeric	One or more channels. (@2) - channel 2 (@1,4) - channels 1 and 4 (@1:3) - channels 1 through 3.	Required parameter

Example

The following command initiates an external data log on channels 1 and 2.

```
INIT:ELOG (@1,2)
```

See Also

[TRIGger:ELOG\[:IMMediate\]](#)

[TRIGger:ELOG:SOURce](#)

[ABORT:ELOG](#)

INITiate[:IMMediate]:TRANsient

Syntax

```
INITiate[:IMMediate]:TRANsient (@<chanlist>)
```

Description

This command enables the output trigger system. When an output trigger is initiated, an event on a selected trigger source causes the specified triggering action to occur. If the trigger system is not initiated, all triggers are ignored.

Parameters

Name	Type	Range of Values	Default Value
<chanlist>	Numeric	One or more channels. (@2) - channel 2 (@1,4) - channels 1 and 4 (@1:3) - channels 1 through 3.	Required parameter

Example

The following command initiates the transient trigger system on channel 1.

```
INIT:TRAN (@1)
```

See Also

[INITiate\[:IMMediate\]:ACQuire](#)

[ABORt:TRANsient](#)

INITiate:CONTInuous:TRANsient

Syntax

```
INITiate:CONTInuous:TRANsient <Bool>, (@<chanlist>)
```

```
INITiate:CONTInuous:TRANsient? (@<chanlist>)
```

Description

This command continuously initiates the output trigger system. This allows multiple triggers to generate multiple output transients with no intermediate commands. The enabled state is ON (1); the disabled state is OFF (0).

NOTE

With continuous triggering disabled, the output trigger system must be initiated for each trigger using the INITiate:TRANsient command.

Parameters

Name	Type	Range of Values	Default Value
<Bool>	Boolean	OFF 0 ON 1	OFF
<chanlist>	Numeric	One or more channels. (@2) - channel 2 (@1,4) - channels 1 and 4 (@1:3) - channels 1 through 3.	Required parameter

Return Format

```
<NR1>
```

The query command returns 0 if continuous transients are disabled (OFF), and 1 if continuous transients are enabled (ON).

Example

The following command continually initiates the transient trigger system on channel 1.

```
INIT:CONT:TRAN ON, (@1)
```

The following query returns the continuous transient trigger state.

```
INIT:CONT:TRAN? (@1)
```

Typical Response: 0

See Also

[INITiate\[:IMMediate\]:TRANsient](#)

[ABORt:TRANsient](#)

MEASure Subsystem Introduction

Measure commands measure the output voltage or current. They trigger the acquisition of new data before returning the reading. Measurements are performed by digitizing the instantaneous output voltage or current for a specified measurement time, storing the results in a buffer, and calculating the average value. Use Measure commands when the measurement does not need to be synchronized with any other event.

SCPI Command	Description
MEASure	
[:SCALar]	
:CURRent	
[:DC]? (@chanlist)	Takes a measurement; returns the average current
:ACDC? (@chanlist)	Takes a measurement; returns the total rms current (AC + DC)
:HIGH? (@chanlist)	Takes a measurement; returns the high level of a current pulse
:LOW? (@chanlist)	Takes a measurement; returns the low level of a current pulse
:MAXimum? (@chanlist)	Takes a measurement, returns the maximum current
:MINimum? (@chanlist)	Takes a measurement, returns the minimum current
:POWer	
[:DC]? (@chanlist)	Takes a measurement; returns the average output power
:VOLTage	
[:DC]? (@chanlist)	Takes a measurement; returns the average voltage
:ACDC? (@chanlist)	Takes a measurement; returns the total rms voltage (AC + DC)
:HIGH? (@chanlist)	Takes a measurement; returns the high level of a voltage pulse
:LOW? (@chanlist)	Takes a measurement; returns the low level of a voltage pulse
:MAXimum? (@chanlist)	Takes a measurement, returns the maximum voltage
:MINimum? (@chanlist)	Takes a measurement, returns the minimum voltage
:ARRay	(Array commands only on N676xA, N678xA SMU and Option 054)
:CURRent [:DC]? (@chanlist)	Takes a measurement; returns the instantaneous output current
:POWer [:DC]? (@chanlist)	Takes a measurement, returns the instantaneous output power
:VOLTage [:DC]? (@chanlist)	Takes a measurement; returns the instantaneous output voltage

MEASure[:SCALar]:CURRent[:DC]?

Syntax

MEASure[:SCALar]:CURRent[:DC]? (@<chanlist>)

Description

This query initiates and triggers a measurement, and returns the average output current in amperes.

NOTE

The time interval, number of points, and windowing function can be programmed on models N676xA, N678xA SMU, or models that have Option 054 (High Speed Test Extensions).

Parameters

Name	Type	Range of Values	Default Value
<chanlist>	Numeric	One or more channels. (@2) - channel 2 (@1,4) - channels 1 and 4 (@1:3) - channels 1 through 3.	Required parameter

Remarks

The MEASure query starts a new measurement immediately. It is not synchronized to any trigger event.

Use the INITiate, trigger, and FETCh sequence if a synchronized measurement is necessary.

The default time interval and number of points settings yield a measurement time of 21 milliseconds per reading (1024 data points at 20.48 microsecond intervals). The default windowing function is Rectangular.

Return Format

<NR3>

The reading is in the form +n.nnnnnnE+nn for each channel specified. Multiple responses are separated by commas.

Example

The following query returns the voltage measured on channel 1.

```
MEAS:CURR? (@1)
```

Typical Response: +1.000000E+01

See Also

[MEASure\[:SCALar\]:VOLTage\[:DC\]?](#)

MEASure[:SCALar]:CURRent:ACDC?**Syntax**

```
MEASure[:SCALar]:CURRent:ACDC? (@<chanlist>)
```

Description

This query initiates and triggers a measurement, and returns the total RMS current (AC + DC) in amperes.

Parameters

Name	Type	Range of Values	Default Value
<chanlist>	Numeric	One or more channels. (@2) - channel 2 (@1,4) - channels 1 and 4 (@1:3) - channels 1 through 3.	Required parameter

Remarks

The MEASure query starts a new measurement immediately. It is not synchronized to any trigger event.

Use the INITiate, trigger, and FETCh sequence if a synchronized measurement is necessary.

The default time interval and number of points settings yield a measurement time of 21 milliseconds per reading (1024 data points at 20.48 microsecond intervals). The default windowing function is Rectangular.

<NR3>

The reading is in the form +n.nnnnnnE+nn for each channel specified. Multiple responses are separated by commas.

Example

The following query returns the RMS current measured on channel 1.

```
MEAS:CURR:ACDC? (@1)
```

Typical Response: +1.000000E+01

See Also

[MEASure\[:SCALar\]:VOLTage:ACDC?](#)

MEASure[:SCALar]:CURRent:HIGH?

Syntax

MEASure[:SCALar]:CURRent:HIGH? (@<chanlist>)

Description

This query initiates and triggers a measurement, and returns the High level of a current pulse waveform in amperes.

The High level calculation generates a histogram of the waveform using 16 bins between the maximum and minimum data points. The bin containing the most data points above the 50% point is the high bin. The average of all the data points in the high bin is returned as the High level. If no high bin contains more than 1.25% of the total number of acquired points, then the maximum data point is returned.

Parameters

Name	Type	Range of Values	Default Value
<chanlist>	Numeric	One or more channels. (@2) - channel 2 (@1,4) - channels 1 and 4 (@1:3) - channels 1 through 3.	Required parameter

Remarks

The MEASure query starts a new measurement immediately. It is not synchronized to any trigger event

Use the INITiate, trigger, and FETCh sequence if a synchronized measurement is necessary.

The default time interval and number of points settings yield a measurement time of 21 milliseconds per reading (1024 data points at 20.48 microsecond intervals). The default windowing function is Rectangular.

Return Format

<NR3>

The reading is in the form +n.nnnnnnE+nn for each channel specified. Multiple responses are separated by commas.

Example

The following query returns the high level of a current pulse on channel 1.

```
MEAS:CURR:HIGH? (@1)
```

Typical Response: +1.000000E+01

See Also

[MEASure\[:SCALar\]:VOLTage:HIGH?](#)

MEASure[:SCALar]:CURRent:LOW?

Syntax

MEASure[:SCALar]:CURRent:LOW? (@<chanlist>)

Description

This query initiates and triggers a measurement, and returns the Low level of a current pulse waveform in amperes.

The Low level calculation generates a histogram of the waveform using 16 bins between the maximum and minimum data points. The bin containing the most data points below the 50% point is the low bin. The average of all the data points in the low bin is returned as the Low level. If no low bin contains less than 1.25% of the total number of acquired points, then the minimum data point is returned.

Parameters

Name	Type	Range of Values	Default Value
<chanlist>	Numeric	One or more channels. (@2) - channel 2 (@1,4) - channels 1 and 4 (@1:3) - channels 1 through 3.	Required parameter

Remarks

The MEASure query starts a new measurement immediately. It is not synchronized to any trigger event

Use the INITiate, trigger, and FETCh sequence if a synchronized measurement is necessary.

The default time interval and number of points settings yield a measurement time of 21 milliseconds per reading (1024 data points at 20.48 microsecond intervals). The default windowing function is Rectangular.

Return Format

<NR3>

The reading is in the form +n.nnnnnnE+nn for each channel specified. Multiple responses are separated by commas.

Example

The following query returns the low level of a current pulse on channel 1.

```
MEAS:CURR:LOW? (@1)
```

Typical Response: +1.000000E+01

See Also

[MEASure\[:SCALar\]:VOLTage:LOW?](#)

MEASure[:SCALar]:CURRent:MAXimum?

Syntax

MEASure[:SCALar]:CURRent:MAXimum? (@<chanlist>)

Description

This query initiates and triggers a measurement, and returns the maximum value in amperes.

Parameters

Name	Type	Range of Values	Default Value
<chanlist>	Numeric	One or more channels. (@2) - channel 2 (@1,4) - channels 1 and 4 (@1:3) - channels 1 through 3.	Required parameter

Remarks

The MEASure query starts a new measurement immediately. It is not synchronized to any trigger event.

Use the INITiate, trigger, and FETCh sequence if a synchronized measurement is necessary.

The default time interval and number of points settings yield a measurement time of 21 milliseconds per reading (1024 data points at 20.48 microsecond intervals). The default windowing function is Rectangular.

Return Format

<NR3>

The reading is in the form +n.nnnnnnE+nn for each channel specified. Multiple responses are separated by commas.

Example

The following query returns the maximum current value on channel 1.

```
MEAS:CURR:MAX? (@1)
```

Typical Response: +1.000000E+01

See Also

[MEASure\[:SCALar\]:VOLTage:MAX?](#)

MEASure[:SCALar]:CURRent:MINimum?

Syntax

```
MEASure[:SCALar]:CURRent:MINimum? (@<chanlist>)
```

Description

This query initiates and triggers a measurement, and returns the minimum value in amperes.

Parameters

Name	Type	Range of Values	Default Value
<chanlist>	Numeric	One or more channels. (@2) - channel 2 (@1,4) - channels 1 and 4 (@1:3) - channels 1 through 3.	Required parameter

Remarks

The MEASure query starts a new measurement immediately. It is not synchronized to any trigger event.

Use the INITiate, trigger, and FETCh sequence if a synchronized measurement is necessary.

The default time interval and number of points settings yield a measurement time of 21 milliseconds per reading (1024 data points at 20.48 microsecond intervals). The default windowing function is Rectangular.

Return Format

```
<NR3>
```

The reading is in the form +n.nnnnnnE+nn for each channel specified. Multiple responses are separated by commas.

Example

The following query returns the minimum current value on channel 1.

```
MEAS:CURR:MIN? (@1)
```

Typical Response: +1.000000E+01

See Also

[MEASure\[:SCALar\]:VOLTage:MIN?](#)

MEASure[:SCALar]:POWer[:DC]?**Syntax**

```
MEASure[:SCALar]:POWer[:DC]? (@<chanlist>)
```

Description

This query initiates and triggers a measurement, and returns the average output power in watts.

NOTE

This command only applies to models N676xA and N678xA SMU. These models have simultaneous voltage and current measurement capability.

Parameters

Name	Type	Range of Values	Default Value
<chanlist>	Numeric	One or more channels. (@2) - channel 2 (@1,4) - channels 1 and 4 (@1:3) - channels 1 through 3.	Required parameter

Remarks

The MEASure query starts a new measurement immediately. It is not synchronized to any trigger event

Use the INITiate, trigger, and FETCh sequence if a synchronized measurement is necessary.

The default time interval and number of points settings yield a measurement time of 21 milliseconds per reading (1024 data points at 20.48 microsecond intervals). The default windowing function is Rectangular.

Return Format

```
<NR3>
```

The reading is in the form +n.nnnnnnE+nn for each channel specified. Multiple responses are separated by commas.

Example

The following query returns the power measured on channel 1.

```
MEAS:POW? (@1)
```

Typical Response: +1.000000E+01

See Also

[MEASure:ARRay:POWer\[:DC\]?](#)

MEASure[:SCALar]:VOLTage[:DC]?**Syntax**

```
MEASure[:SCALar]:VOLTage[:DC]? (@<chanlist>)
```

Description

This query initiates and triggers a measurement, and returns the average output voltage in volts.

NOTE

The time interval, number of points, and windowing function can be programmed on models N676xA, N678xA SMU, or models that have Option 054 (High Speed Test Extensions).

Parameters

Name	Type	Range of Values	Default Value
<chanlist>	Numeric	One or more channels. (@2) - channel 2 (@1,4) - channels 1 and 4 (@1:3) - channels 1 through 3.	Required parameter

Remarks

The MEASure query starts a new measurement immediately. It is not synchronized to any trigger event.

Use the INITiate, trigger, and FETCh sequence if a synchronized measurement is necessary.

The default time interval and number of points settings yield a measurement time of 21 milliseconds per reading (1024 data points at 20.48 microsecond intervals). The default windowing function is Rectangular.

Return Format

```
<NR3>
```

The reading is in the form +n.nnnnnnE+nn for each channel specified. Multiple responses are separated by commas.

Example

The following query returns the voltage measured on channel 1.

```
MEAS:VOLT? (@1)
```

Typical Response: +5.000000E+01

See Also

[MEASure\[:SCALar\]:CURRENT\[:DC\]?](#)

MEASure[:SCALar]:VOLTage:ACDC?

Syntax

MEASure[:SCALar]:VOLTage:ACDC? (@<chanlist>)

Description

This query initiates and triggers a measurement, and returns the total RMS voltage (AC + DC) in volts.

Parameters

Name	Type	Range of Values	Default Value
<chanlist>	Numeric	One or more channels. (@2) - channel 2 (@1,4) - channels 1 and 4 (@1:3) - channels 1 through 3.	Required parameter

Remarks

The MEASure query starts a new measurement immediately. It is not synchronized to any trigger event.

Use the INITiate, trigger, and FETCh sequence if a synchronized measurement is necessary.

The default time interval and number of points settings yield a measurement time of 21 milliseconds per reading (1024 data points at 20.48 microsecond intervals). The default windowing function is Rectangular.

Return Format

<NR3>

The reading is in the form +n.nnnnnnE+nn for each channel specified. Multiple responses are separated by commas.

Example

The following query returns the RMS voltage measured on channel 1.

```
MEAS:VOLT:ACDC? (@1)
```

Typical Response: +5.000000E+01

See Also

[MEASure\[:SCALar\]:CURRENT:ACDC?](#)

MEASure[:SCALar]:VOLTage:HIGH?

Syntax

```
MEASure[:SCALar]:VOLTage:HIGH? (@<chanlist>)
```

Description

This query initiates and triggers a measurement, and returns the High level of a voltage pulse waveform in volts.

The High level calculation generates a histogram of the waveform using 16 bins between the maximum and minimum data points. The bin containing the most data points above the 50% point is the high bin. The average of all the data points in the high bin is returned as the High level. If no high bin contains more than 1.25% of the total number of acquired points, then the maximum data point is returned.

Parameters

Name	Type	Range of Values	Default Value
<chanlist>	Numeric	One or more channels. (@2) - channel 2 (@1,4) - channels 1 and 4 (@1:3) - channels 1 through 3.	Required parameter

Remarks

The MEASure query starts a new measurement immediately. It is not synchronized to any trigger event

Use the INITiate, trigger, and FETCh sequence if a synchronized measurement is necessary.

The default time interval and number of points settings yield a measurement time of 21 milliseconds per reading (1024 data points at 20.48 microsecond intervals). The default windowing function is Rectangular.

Return Format

```
<NR3>
```

The reading is in the form +n.nnnnnnE+nn for each channel specified. Multiple responses are separated by commas.

Example

The following query returns the high level of a voltage pulse on channel 1.

```
MEAS:VOLT:HIGH? (@1)
```

Typical Response: +5.000000E+01

See Also

[MEASure\[:SCALar\]:CURRent:HIGH?](#)

MEASure[:SCALar]:VOLTage:LOW?

Syntax

```
MEASure[:SCALar]:VOLTage:LOW? (@<chanlist>)
```

Description

This query initiates and triggers a measurement, and returns the Low level of a voltage pulse waveform in volts.

The Low level calculation generates a histogram of the waveform using 16 bins between the maximum and minimum data points. The bin containing the most data points below the 50% point is the low bin. The average of all the data points in the low bin is returned as the Low level. If no low bin contains less than 1.25% of the total number of acquired points, then the minimum data point is returned.

Parameters

Name	Type	Range of Values	Default Value
<chanlist>	Numeric	One or more channels. (@2) - channel 2 (@1,4) - channels 1 and 4 (@1:3) - channels 1 through 3.	Required parameter

Remarks

The MEASure query starts a new measurement immediately. It is not synchronized to any trigger event

Use the INITiate, trigger, and FETCh sequence if a synchronized measurement is necessary.

The default time interval and number of points settings yield a measurement time of 21 milliseconds per reading (1024 data points at 20.48 microsecond intervals). The default windowing function is Rectangular.

Return Format

```
<NR3>
```

The reading is in the form +n.nnnnnnE+nn for each channel specified. Multiple responses are separated by commas.

Example

The following query returns the low level of a voltage pulse on channel 1.

```
MEAS:VOLT:LOW? (@1)
```

Typical Response: +5.000000E+01

See Also

[MEASure\[:SCALar\]:CURRent:LOW?](#)

MEASure[:SCALar]:VOLTage:MAXimum?

Syntax

MEASure[:SCALar]:VOLTage:MAXimum? (@<chanlist>)

Description

This query initiates and triggers a measurement, and returns the maximum value in volts.

Parameters

Name	Type	Range of Values	Default Value
<chanlist>	Numeric	One or more channels. (@2) - channel 2 (@1,4) - channels 1 and 4 (@1:3) - channels 1 through 3.	Required parameter

Remarks

The MEASure query starts a new measurement immediately. It is not synchronized to any trigger event.

Use the INITiate, trigger, and FETCh sequence if a synchronized measurement is necessary.

The default time interval and number of points settings yield a measurement time of 21 milliseconds per reading (1024 data points at 20.48 microsecond intervals). The default windowing function is Rectangular.

Return Format

<NR3>

The reading is in the form +n.nnnnnnE+nn for each channel specified. Multiple responses are separated by commas.

Example

The following query returns the maximum voltage value on channel 1.

```
MEAS:VOLT:MAX? (@1)
```

Typical Response: +1.000000E+01

See Also

[MEASure\[:SCALar\]:CURRENT:MAX?](#)

MEASure[:SCALar]:VOLTage:MINimum?

Syntax

MEASure[:SCALar]:VOLTage:MINimum? (@<chanlist>)

Description

This query initiates and triggers a measurement, and returns the minimum value in volts.

Parameters

Name	Type	Range of Values	Default Value
<chanlist>	Numeric	One or more channels. (@2) - channel 2 (@1,4) - channels 1 and 4 (@1:3) - channels 1 through 3.	Required parameter

Remarks

The MEASure query starts a new measurement immediately. It is not synchronized to any trigger event.

Use the INITiate, trigger, and FETCh sequence if a synchronized measurement is necessary.

The default time interval and number of points settings yield a measurement time of 21 milliseconds per reading (1024 data points at 20.48 microsecond intervals). The default windowing function is Rectangular.

Return Format

<NR3>

The reading is in the form +n.nnnnnnE+nn for each channel specified. Multiple responses are separated by commas.

Example

The following query returns the minimum voltage value on channel 1.

```
MEAS:VOLT:MIN? (@1)
```

Typical Response: +1.000000E+01

See Also

[MEASure\[:SCALar\]:CURRENT:MIN?](#)

MEASure:ARRay:CURRent[:DC]?

Syntax

MEASure:ARRay:CURRent[:DC]? (@<chanlist>)

Description

This query initiates and triggers a measurement and returns an array containing the digitized output current in amperes.

The sampling rate is set by SENSE:SWEep:TINterval. The position of the trigger relative to the beginning of the data buffer is determined by SENSE:SWEep:OFFSet:POINTs. The number of points returned is set by SENSE:SWEep:POINTs.

NOTE

This command is used only with models N676xA, N678xA SMU, or models that have Option 054 (High Speed Test Extensions).

Parameters

Name	Type	Range of Values	Default Value
<chanlist>	Numeric	One or more channels. (@2) - channel 2 (@1,4) - channels 1 and 4 (@1:3) - channels 1 through 3.	Required parameter

Remarks

The MEASure query starts a new measurement immediately. It is not synchronized to any trigger event.

Use the INITiate, trigger, and FETCh sequence if a synchronized measurement is necessary.

The default time interval and number of points settings yield a measurement time of 21 milliseconds per reading (1024 data points at 20.48 microsecond intervals). The default windowing function is Rectangular.

Return Format

The return format depends on the settings of the FORMat:BORDER and FORMat[:DATA] commands. When the data format is set to ASCII, returned values are comma separated. Only one channel can be queried when the format is ASCII. When the data format is set to REAL, data is returned as single precision floating point numbers in definite length arbitrary block response format. Each block contains all the records for one of the channels given in the <chanlist> parameter. If multiple channels are given, then each definite length arbitrary block of data is separated by a comma.

<NR3> [,<NR3>]
or
<block> [,<block>]

Example

The following query returns the current measured on channel 1.

```
MEAS:ARR:CURR? (@1)
```

See Also

[MEASure:ARRay:VOLTage\[:DC\]?](#)

[SENSe:SWEEp:TINterval](#)

[SENSe:SWEEp:OFFset:POINTs](#)

[SENSe:SWEEp:POINTs](#)

MEASure:ARRay:POWer[:DC]?

Syntax

MEASure:ARRay:POWer[:DC]? (@<chanlist>)

Description

This query initiates and triggers a measurement and returns an array containing the digitized output power in watts.

The sampling rate is set by SENSE:SWEEp:TINterval. The position of the trigger relative to the beginning of the data buffer is determined by SENSE:SWEEp:OFFSet:POINts. The number of points returned is set by SENSE:SWEEp:POINts.

NOTE

This command only applies to models N676xA and N678xA SMU. These models have simultaneous voltage and current measurement capability.

Parameters

Name	Type	Range of Values	Default Value
<chanlist>	Numeric	One or more channels. (@2) - channel 2 (@1,4) - channels 1 and 4 (@1:3) - channels 1 through 3.	Required parameter

Remarks

The MEASure query starts a new measurement immediately. It is not synchronized to any trigger event.

Use the INITiate, trigger, and FETCh sequence if a synchronized measurement is necessary.

The default time interval and number of points settings yield a measurement time of 21 milliseconds per reading (1024 data points at 20.48 microsecond intervals). The default windowing function is Rectangular.

Return Format

The return format depends on the settings of the FORMat:BORDER and FORMat[:DATA] commands. When the data format is set to ASCII, returned values are comma separated. Only one channel can be queried when the format is ASCII. When the data format is set to REAL, data is returned as single precision floating point numbers in definite length arbitrary block response format. Each block contains all the records for one of the channels given in the <chanlist> parameter. If multiple channels are given, then each definite length arbitrary block of data is separated by a comma.

<NR3> [,<NR3>]
or
<block> [,<block>]

Example

The following query returns the power measured on channel 1.

```
MEAS:ARR:POW? (@1)
```

See Also

[SENSe:SWEep:TINterval](#)

[SENSe:SWEep:OFFset:POINts](#)

[SENSe:SWEep:POINts](#)

MEASure:ARRay:VOLTage[:DC]?**Syntax**

MEASure:ARRay:VOLTage[:DC]? (@<chanlist>)

Description

This query initiates and triggers a measurement and returns an array containing the digitized output voltage in volts.

The sampling rate is set by SENSE:SWEep:TINterval. The position of the trigger relative to the beginning of the data buffer is determined by SENSE:SWEep:OFFSet:POINts. The number of points returned is set by SENSE:SWEep:POINts.

NOTE

This command is used only with models N676xA, N678xA SMU, or models that have Option 054 (High Speed Test Extensions).

Parameters

Name	Type	Range of Values	Default Value
<chanlist>	Numeric	One or more channels. (@2) - channel 2 (@1,4) - channels 1 and 4 (@1:3) - channels 1 through 3.	Required parameter

Remarks

The MEASure query starts a new measurement immediately. It is not synchronized to any trigger event.

Use the INITiate, trigger, and FETCh sequence if a synchronized measurement is necessary.

The default time interval and number of points settings yield a measurement time of 21 milliseconds per reading (1024 data points at 20.48 microsecond intervals). The default windowing function is Rectangular.

Return Format

The return format depends on the settings of the FORMat:BORDER and FORMat[:DATA] commands. When the data format is set to ASCII, returned values are comma separated. Only one channel can be queried when the format is ASCII. When the data format is set to REAL, data is returned as single precision floating point numbers in definite length arbitrary block response format. Each block contains all the records for one of the channels given in the <chanlist> parameter. If multiple channels are given, then each definite length arbitrary block of data is separated by a comma.

<NR3> [,<NR3>]
or
<block> [,<block>]

Example

The following query returns the voltage measured on channel 1.

```
MEAS:ARR:VOLT? (@1)
```

See Also

[MEASure:ARRay:CURRent\[:DC\]?](#)

[SENSe:SWEEp:TINterval](#)

[SENSe:SWEEp:OFFset:POINts](#)

[SENSe:SWEEp:POINts](#)

OUTPut Subsystem Introduction

The Output subsystem controls the output, power-on, protection, and relay functions.

SCPI Command	Description
OUTPut	
[:STATe] <Bool> [,NORelay], (@chanlist)	Enables/disables the specified output channel(s)
:COUPlE	
[:STATe] <Bool>	Enables/disables channel coupling for output synchronization
:CHANNeL [<NR1> {,<NR1>}]	Selects which channels are coupled
:DOFFset <NRf>	Specifies a maximum delay offset to synchronize output changes
:MAX	
:DOFFset?	Returns the maximum delay offset required for a mainframe
:DELay	
:FALL <NRf+>, (@chanlist)	Sets the output turn-off sequence delay
:RISE <NRf+>, (@chanlist)	Sets the output turn-on sequence delay
:PMODE VOLTage CURRent, (@chanlist)	Sets the mode for turn on/off transitions (N6761A, N6762A)
:TMODE HIGHZ LOWZ, (@chanlist)	Specifies the turn-on/turn-off impedance (only on N678xA SMU)
:INHibit	
:MODE LATCHing LIVE OFF	Sets the remote inhibit input
:PON	
:STATe RST RCL0	Programs the power-on state
:PROTection	
:CLEar (@chanlist)	Resets latched protection
:COUPlE <Bool>	Enables/disables channel coupling for protection faults
:DELay <NRf+>, (@chanlist)	Sets over-current protection programming delay
:OSCillation <Bool>, (@chanlist)	Enables/disables output oscillation protection (N678xA SMU)
:WDOG	
[:STATe] <Bool>	Enables/disables the I/O watchdog timer
:DELay <NRf+>	Sets the watchdog timer delay
:RELay	
:POLarity NORMAl REVerse, (@chanlist)	Sets the output relay polarity (Option 760)

OUTPut[:STATe]

Syntax

OUTPut[:STATe] <Bool> [,NORelay], (@<chanlist>)

OUTPut[:STATe]? (@<chanlist>)

Description

This command enables or disables the specified output channel(s). The enabled state is ON (1); the disabled state is OFF (0). The state of a disabled output is a condition of zero output voltage and zero source current. If output and sense relays are installed (Option 761), the relays will open when the output is disabled and close when the output is enabled.

The optional **NORelay** parameter lets you turn the output state on or off and leave the state of the relays unchanged. When not specified, the relays open and close as the output is turned off and on. Relays only open and close when the output is at zero voltage; zero current.

Parameters

Name	Type	Range of Values	Default Value
<Bool>	Boolean	OFF 0 ON 1	OFF
<chanlist>	Numeric	One or more channels. (@2) - channel 2 (@1,4) - channels 1 and 4 (@1:3) - channels 1 through 3.	Required parameter

Remarks

Separate delays can be programmed for the off-to-on and the on-to-off transition using OUTPut:DElay:RISE and OUTput:DElay:FALL.

Because of internal circuit start-up procedures and any installed relay options, the OUTPut ON command may take between 35 and 50 milliseconds to complete its function. The OUTPut OFF command may take between 20 and 25 milliseconds to complete its function. To mitigate this built-in delay, you can program the output to zero volts rather than using the output on/off command.

Return Format

<NR1>

The query command returns 0 if the output is OFF, and 1 if the output is ON.

Example

The following command turns the output of channel 2 on.

```
OUTP ON, (@2)
```

The following query returns the output state of channel 4.

```
OUTP? (@4)
```

Typical Response: 0

See Also

[OUTPut:PON:STATe](#)

[OUTPut\[:STATe\]:DELay:FALL](#)

[OUTPut\[:STATe\]:DELay:RISE](#)

OUTPut[:STATe]:COUPle[:STATe]

Syntax

```
OUTPut[:STATe]:COUPle[:STATe] <Bool>
```

```
OUTPut[:STATe]:COUPle[:STATe]?
```

Description

This command enables or disables output coupling or synchronization between multiple output channels. When output channels have been coupled and the Digital connector pins have been properly configured, enabling this function allows you to control the output state of multiple outputs in multiple mainframes by controlling the output state of one output channel. Refer to Appendix D in the User's Guide for detailed information.

Parameters

Name	Type	Range of Values	Default Value
<Bool>	Boolean	OFF 0 ON 1	OFF

Remarks

When this command is sent, all output channels in the mainframe will go to the output Off state.

This setting is non-volatile and not affected by *RST.

Return Format

```
<NR1>
```

The query command returns 1 if outputs are coupled, and 0 if outputs are not coupled.

Example

The following command turns output coupling on.

```
OUTP:COUP ON
```

The following query returns the output coupling state.

```
OUTP:COUP?
```

Typical Response: 0

See Also

[OUTPut\[:STATe\]:COUPle:CHANnel](#)

[OUTPut\[:STATe\]:COUPle:DOFFset](#)

[\[SOURce:\]DIGital:PIN<1-7>:FUNCTION](#)

OUTPut[:STATe]:COUPle:CHANnel

Syntax

```
OUTPut[:STATe]:COUPle:CHANnel [<channel>
{,<channel>}]
```

```
OUTPut[:STATe]:COUPle:CHANnel?
```

Description

This command specifies which output channels in the mainframe are controlled by the output synchronization function. The output channels that have been synchronized or coupled will turn on and off together when any one of them is turned on or off, or when a signal is received from a digital connector pin that has been configured as an On couple or an Off couple pin. Refer to Appendix D in the User's Guide for detailed information.

There can be only one set of coupled channels in a mainframe. If another coupled set is programmed, the existing set is deleted and the new set applies. If you do not specify an output channel, this command will uncouple all output channels on the mainframe.

Parameters

Name	Type	Range of Values	Default Value
<channel>	NR1	1 2 3 4	Required parameter

Remarks

When this command is sent, all output channels in the mainframe will go to the output Off state.

This setting is non-volatile and not affected by *RST.

Return Format

```
<NR1>
```

The query command returns the channels that are coupled. Multiple responses are separated by commas.

Example

The following command couples channels 1, 2, and 4.

```
OUTP:COUP:CHAN 1,2,4
```

The following query returns the output coupling state.

```
OUTP:COUP:CHAN?
```

Typical Response: 1,2,4

See Also

[OUTPut\[:STATe\]:COUPle\[:STATe\]](#)

[OUTPut\[:STATe\]:COUPle:DOFFset](#)

[\[SOURce:\]DIGital:PIN<1-7>:FUNCTion](#)

OUTPut[:STATe]:COUPle:DOFFset

Syntax

```
OUTPut[:STATe]:COUPle:DOFFset <delay>
```

```
OUTPut[:STATe]:COUPle:DOFFset?
```

Description

This command specifies a maximum delay offset to synchronize the output state changes. Units are in seconds. Setting this time to the maximum delay offset specified for any output channel that is being coupled will cause all of the output channels to synchronize to the turn-on times specified by OUTput:DELay:RISE. This delay only applies to coupled channels, provided OUTput:COUPle is enabled. Refer to Appendix D in the User's Guide for detailed information.

Parameters

Name	Type	Range of Values	Default Value
<delay>	NRf	0 - 1.023	Required parameter

Remarks

When this command is sent, all output channels in the mainframe will go to the output Off state.

This setting is non-volatile and not affected by *RST.

Return Format

```
<NR3>
```

The query command returns the programmed delay offset in the form +n.nnnnnnE+nn.

Example

The following specifies a delay offset of 60 milliseconds.

```
OUTP:COUP:DOFF 0.06
```

The following query returns the delay offset.

```
OUTP:COUP:DOFF?
```

Typical Response: +6.000000E-02

See Also

[OUTPut\[:STATe\]:COUPle\[:STATe\]](#)

[OUTPut\[:STATe\]:COUPle:CHANnel](#)

[OUTPut\[:STATe\]:DELay:RISE](#)

OUTPut[:STATe]:COUPle:MAX:DOFFset?

Syntax

```
OUTPut [ :STATe ] :COUPle :MAX :DOFFset ?
```

Description

This query returns the largest delay offset that is required for the output channels installed in this mainframe. Refer to Appendix D in the User's Guide for detailed information.

Return Format

<NR3>

The query command returns the maximum delay offset in the form +n.nnnnnnE+nn.

Example

The following query returns the maximum delay offset.

```
OUTP : COUP : MAX : DOFF ?
```

Typical Response: +3.000000E-02

See Also

[OUTPut\[:STATe\]:COUPle:DOFFset](#)

OUTPut[:STATe]:DELay:FALL

Syntax

```
OUTPut[:STATe]:DELay:FALL <delay>, (@<chanlist>)
```

```
OUTPut[:STATe]:DELay:FALL? [MIN|MAX,] (@<chanlist>)
```

Description

This command sets the delay in seconds that the instrument waits before disabling the specified output. This allows multiple output channels to turn off in sequence. Each output will not turn off until its delay time has elapsed. This command affects on-to-off transitions including changes in the [OUTPut\[:STATe\]](#) as well as transitions due to changes in the voltage range or current range. It does NOT affect transitions to off caused by protection functions. Delay times can be programmed from 0 to 1023 seconds with the following resolution:

Range in seconds	Resolution
0 to 1.023E-4	100 nanoseconds
1.03E-4 to 1.023E-3	1 microsecond
1.03E-3 to 1.023E-2	10 microseconds
1.03E-2 to 1.023E-1	100 microseconds
1.03E-1 to 1.023E+0	1 millisecond
1.03E+0 to 1.023E+1	10 milliseconds
1.03E+1 to 1.023E+2	100 milliseconds
1.03E+2 to 1.023E+3	1 second

Parameters

Name	Type	Range of Values	Default Value
<delay>	NRf+	0 - 1.023 MIN MAX	0
<chanlist>	Numeric	One or more channels. (@2) - channel 2 (@1,4) - channels 1 and 4 (@1:3) - channels 1 through 3.	Required parameter

Remarks

Refer to Appendix D in the User's Guide for information about output synchronization.

Return Format

```
<NR3>
```

The query command returns the programmed delay time. The reading is in the form +n.nnnnnnE+nn.

Example

The following command sets a delay of 0.5 seconds before turning off the output of channel 2.

```
OUTP:DEL:FALL 0.5,(@2)
```

The following query returns the maximum allowable delay time of channel 1.

```
OUTP:DEL:FALL? MAX,(@1)
```

Typical Response: +1.023000E+00

See Also

[OUTPut\[:STATe\]](#)

[OUTPut\[:STATe\]:DELay:RISE](#)

OUTPut[:STATe]:DELay:RISE

Syntax

```
OUTPut[:STATe]:DELay:RISE <delay>, (@<chanlist>)
```

```
OUTPut[:STATe]:DELay:RISE? [MIN|MAX,] (@<chanlist>)
```

Description

This command sets the delay in seconds that the instrument waits before enabling the specified output. This allows multiple output channels to turn on in sequence. Each output will not turn on until its delay time has elapsed. This command affects all off-to-on transitions including changes in the [OUTPut\[:STATe\]](#) as well as transitions due to [OUTPut:PROTection:CLEar](#). Delay times can be programmed from 0 to 1023 seconds with the following resolution:

Range in seconds	Resolution
0 to 1.023E-4	100 nanoseconds
1.03E-4 to 1.023E-3	1 microsecond
1.03E-3 to 1.023E-2	10 microseconds
1.03E-2 to 1.023E-1	100 microseconds
1.03E-1 to 1.023E+0	1 millisecond
1.03E+0 to 1.023E+1	10 milliseconds
1.03E+1 to 1.023E+2	100 milliseconds
1.03E+2 to 1.023E+3	1 second

Parameters

Name	Type	Range of Values	Default Value
<delay>	NRf+	0 - 1.023 MIN MAX	0
<chanlist>	Numeric	One or more channels. (@2) - channel 2 (@1,4) - channels 1 and 4 (@1:3) - channels 1 through 3.	Required parameter

Remarks

Output channel turn-on characteristics vary across the three power module types - DC Power, Auto ranging, and Precision. Refer to Appendix D in the User's Guide for more information about turn-on synchronization. When several channels of the **same** module type are programmed off-to-on by this command, output sequencing is precisely determined by the programmed turn-on delays.

When outputs of different module types are sequenced using this command, there may be an additional offset of a few milliseconds from one output to another. This offset is the same for each module type and is repeatable. Once you have characterized this offset, using

an oscilloscope for example, you can adjust the programmed delays to compensate for the offset and give the desired output sequencing.

Outputs within the same module type can also have an offset if one model has output relays (Option 761) and another does not. These offsets are also repeatable and can be compensated by adjusting the programmed delay values.

Return Format

<NR3>

The query command returns the programmed delay time. The reading is in the form +n.nnnnnnE+nn.

Example

The following command sets a delay of 0.5 seconds before turning on the output of channel 2.

```
OUTP:DEL:RISE 0.5,(@2)
```

The following query returns the maximum allowable delay time of channel 1.

```
OUTP:DEL:RISE? MAX,(@1)
```

Typical Response: +1.023000E+00

See Also

[OUTPut\[:STATe\]](#)

[OUTPut\[:STATe\]:DELay:FALL](#)

OUTPut[:STATe]:PMODE

Syntax

```
OUTPut[:STATe]:PMODE <mode>, (@<chanlist>)
```

```
OUTPut[:STATe]:PMODE? (@<chanlist>)
```

Description

This command sets the preferred mode for output on or output off transitions. It allows output state transitions to be optimized for either constant voltage or constant current operation. Turn-on and turn-off overshoots are minimized for the preferred mode of operation.

VOLTage Minimizes output on/off voltage overshoots in constant voltage operation.

CURRent Minimizes output on/off current overshoots in constant current operation.

NOTE

This command only applies to models N6761A and N6762A.

Parameters

Name	Type	Range of Values	Default Value
<mode>	CPD	VOLTage CURRent	VOLTage
<chanlist>	Numeric	One or more channels. (@2) - channel 2 (@1,4) - channels 1 and 4 (@1:3) - channels 1 through 3.	Required parameter

Return Format

```
<CRD>
```

The query command returns VOLT or CURR.

Example

The following command sets the preferred mode of channel 1 to CURRent.

```
OUTP:PMOD CURR,(@1)
```

The following query returns the setting of the preferred mode of channel 2.

```
OUTP:PMOD?(@2)
```

Typical Response: VOLT

See Also

[OUTPut\[:STATe\]](#)

OUTPut[:STATe]:TMODe

Syntax

```
OUTPut[:STATe]:TMODe <mode>, (@<chanlist>)
```

```
OUTPut[:STATe]:TMODe? (@<chanlist>)
```

Description

This command specifies the output impedance mode at turn-off.

HIGHZ Sets the output to a high impedance mode at turn-off. In high impedance mode, the output relays are opened while the output remains at its set value.

LOWZ Sets the output to a low impedance mode at turn-off. In low impedance mode, the output is first down-programmed to zero, after which the output relays are opened.

NOTE

This command is used only with models N678xA SMU.

Parameters

Name	Type	Range of Values	Default Value
<mode>	CPD	HIGHZ LOWZ	HIGHZ
<chanlist>	Numeric	One or more channels. (@2) - channel 2 (@1,4) - channels 1 and 4 (@1:3) - channels 1 through 3.	Required parameter

Return Format

```
<CRD>
```

The query command returns HIGHZ or LOWZ.

Example

The following command sets the turn-off mode of channel 1 to high impedance.

```
OUTP:TMOD HIGHZ, (@1)
```

The following query returns the setting of the turn-off mode of channel 2.

```
OUTP:TMOD? (@2)
```

Typical Response: LOWZ

See Also

[OUTPut\[:STATe\]](#)

OUTPut:INHibit:MODE

Syntax

```
OUTPut:INHibit:MODE <mode>
```

```
OUTPut:INHibit:MODE?
```

Description

This command selects the mode of operation of the Inhibit input (INH). The inhibit function shuts down ALL output channels in response to an external signal on the Inhibit input. If an output channel has been turned off by [OUTPut\[:STATe\]](#), the inhibit function does not affect the output channel while it is in the OFF state. The Inhibit mode setting is stored in non-volatile memory.

The following modes can be selected:

- LATChing** Causes a logic-true transition on the Inhibit input to disable all outputs. The outputs remain disabled until the Inhibit input is returned to logic-false and the latched INH status bit is cleared by sending the [OUTPut:PROTEction:CLEar](#) command or a protection clear command from the front panel.
- LIVE** Allows the enabled outputs to follow the state of the Inhibit input. When the Inhibit input is true, the outputs are disabled. When the Inhibit input is false, the outputs are re-enabled.
- OFF** The Inhibit input is ignored.

Parameters

Name	Type	Range of Values	Default Value
<mode>	CPD	LATChing LIVE OFF	Required parameter

Return Format

```
<CRD>
```

The query command returns LATC, LIVE, or OFF.

Example

The following command sets the Inhibit Input to Live mode.

```
OUTP:INH:MODE LIVE
```

The following query returns the setting of the Inhibit Input.

```
OUTP:INH:MODE?
```

Typical Response: OFF

See Also

[OUTPut\[:STATe\]](#)

[OUTPut:PROTection:CLEar](#)

OUTPut:PON:STATe

Syntax

OUTPut:PON:STATe <state>

OUTPut:PON:STATe?

Description

This command determines if the power-on state is set to the *RST (RST) state or the instrument state stored in memory location 0 (RCL0). The parameter is saved in non-volatile memory. Instrument states can be stored using the *SAV command.

When shipped from the factory, the [*RST](#) command is issued at power-on.

Parameters

Name	Type	Range of Values	Default Value
<state>	CPD	RST RCL0	Required parameter

Return Format

<CRD>

The query command returns RST or RCL0.

Example

The following command sets the power-on state to the *RST state.

```
OUTPut:PON:STAT RST
```

The following query returns the setting of the power-on state.

```
OUTPut:PON:STAT?
```

Typical Response: RST

See Also

[*RCL](#)

[*RST](#)

[*SAV](#)

OUTPut:PROTection:CLEar

Syntax

OUTPut:PROTection:CLEar (@<chanlist>)

Description

This command clears the latched protection status that disables the output when an over-voltage, over-temperature, over-current, inhibit signal, power-fail condition, or on some models, a power-limit condition is detected.

All conditions that generate the fault must be removed before the latched status can be cleared. The output is restored to the state it was in before the fault condition occurred.

NOTE

If a protection shutdown occurs during an output list, the list continues running even though the output is disabled. When the protection status is cleared and the output becomes enabled again, the output will be set to the values of the step that the list is presently at.

Parameters

Name	Type	Range of Values	Default Value
<chanlist>	Numeric	One or more channels. (@2) - channel 2 (@1,4) - channels 1 and 4 (@1:3) - channels 1 through 3.	Required parameter

Example

The following command clears the latched protection status of channel 1.

```
OUTP:PROT:CLE (@1)
```

See Also

[OUTPut:PROTection:COUPle](#)

[OUTPut:PROTection:DELay](#)

OUTPut:PROTection:COUPle

Syntax

```
OUTPut:PROTection:COUPle <Bool>
```

```
OUTPut:PROTection:COUPle?
```

Description

This command enables or disables output coupling for protection faults. When enabled, ALL output channels are disabled when a protection fault occurs on any output channel. The enabled state is On (1); the disabled state is Off (0). When disabled, only the affected output channel is disabled when a protection fault is triggered.

Parameters

Name	Type	Range of Values	Default Value
<Bool>	Boolean	OFF 0 ON 1	OFF

Return Format

```
<NR1>
```

The query command returns 0 if the protection coupling is OFF (disabled), and 1 if the protection coupling is ON (enabled).

Example

The following command enables protection coupling.

```
OUTP:PROT:COUP ON
```

The following query returns the protection coupling setting.

```
OUTP:PROT:COUP?
```

Typical Response: 0

See Also

[OUTPut:PROTection:CLEar](#)

[OUTPut:PROTection:DELay](#)

OUTPut:PROTection:DELaY

Syntax

```
OUTPut:PROTection:DELaY <delay>, (@<chanlist>)
OUTPut:PROTection:DELaY? [MIN|MAX,] (@<chanlist>)
```

Description

This command sets the over-current protection delay. The over-current protection function will not be triggered on the specified output channel during the delay time. After the delay time has expired, the over-current protection function will be active. This prevents momentary changes in output status from triggering the over-current protection function. Programmed values can range from 0 to 255 milliseconds in increments of 1 millisecond.

The operation of over-current protection is affected by the setting of the current protection delay start event, which is specified by [\[SOURCE:|CURRENT:PROTection:DELaY:START](#).

Parameters

Name	Type	Range of Values	Default Value
<delay>	Nrf+	0 - 0.255 MIN MAX	20 ms
<chanlist>	Numeric	One or more channels. (@2) - channel 2 (@1,4) - channels 1 and 4 (@1:3) - channels 1 through 3.	Required parameter

Remarks

This command is the same as [\[SOURCE:|CURRENT:PROTection:DELaY](#).

Return Format

<NR3>

The query command returns the programmed delay time. The reading is in the form +n.nnnnnnnE+nn.

Example

The following command sets a current protection delay of 0.2 seconds for channel 2.

```
OUTP:PROT:DEL 0.2,(@2)
```

The following query returns the maximum allowable current protection delay of channel 1.

```
OUTP:PROT:DEL? MAX,(@1)
```

Typical Response: +2.550000E-01

See Also

[\[SOURCE:|CURRENT:PROTECTION:DELAY](#)

[\[SOURCE:|CURRENT:PROTECTION:DELAY:START](#)

[\[SOURCE:|CURRENT:PROTECTION:STATE](#)

[OUTPUT:PROTECTION:CLEAR](#)

OUTPut:PROTection:OSCillation[:STATe]

Syntax

```
OUTPut:PROTection:OSCillation[:STATe] <Bool>,  
(@<chanlist>)
```

```
OUTPut:PROTection:OSCillation[:STATe]? (@<chanlist>)
```

Description

This command enables/disables output oscillation for protection. The enabled state is On (1); the disabled state is Off (0). If capacitive loads cause the output to oscillate on the default or any of the other bandwidth settings, this protection function will detect the oscillation and latch the output off.

NOTE

This command is used only with models N678xA SMU.

Parameters

Name	Type	Range of Values	Default Value
<Bool>	Boolean	OFF 0 ON 1	OFF
<chanlist>	Numeric	One or more channels. (@2) - channel 2 (@1,4) - channels 1 and 4 (@1:3) - channels 1 through 3.	Required parameter

Return Format

```
<NR1>
```

The query command returns 0 if oscillation protection is OFF (disabled), and 1 if oscillation protection is ON (enabled).

Example

The following command enables oscillation protection of channel 1.

```
OUTPut:PROT:OSC ON, (@1)
```

The following query returns the oscillation protection setting.

```
OUTPut:PROT:OSC? (@1)
```

Typical Response: 1

See Also

[\[SOURCE:VOLTage:BWIDth\]](#)

OUTPut:PROTection:WDOG[:STATe]**Syntax**

```
OUTPut:PROTection:WDOG[:STATe] <Bool>
```

```
OUTPut:PROTection:WDOG[:STATe]?
```

Description

This command enables or disables the output watchdog timer. When enabled, all output channels are disabled if there is no I/O activity on any remote interface within the time period specified by [OUTput:PROTection:WDOG:DELay](#). The outputs are latched off but the programmed output states are not changed. The enabled state is On (1); the disabled state is Off (0).

Parameters

Name	Type	Range of Values	Default Value
<Bool>	Boolean	OFF 0 ON 1	OFF

Return Format

```
<NR1>
```

The query command returns 0 if the watchdog timer is OFF (disabled), and 1 if the watchdog timer is ON (enabled).

Example

The following command enables the output watchdog timer.

```
OUTP:PROT:WDOG ON
```

The following query returns the output watchdog timer setting.

```
OUTP:PROT:WDOG?
```

Typical Response: 0

See Also

[OUTput:PROTection:WDOG:DELay](#)

OUTPut:PROTection:WDOG:DELaY

Syntax

OUTPut:PROTection:WDOG:DELaY <delay>

OUTPut:PROTection:WDOG:DELaY? [MIN|MAX]

Description

This command sets the output watchdog delay time. When the output watchdog timer is enabled, all output channels are disabled if there is no SCPI I/O activity on any remote interface (USB, LAN, GPIB) within the delay time. The watchdog timer function is NOT reset by activity on the front panel or when using the Web server - the outputs will still shut down after the time period has elapsed. Programmed values can range from 1 to 3600 seconds in 1 second increments.

Parameters

Name	Type	Range of Values	Default Value
<delay>	NRf+	1 - 3600 MIN MAX	60 seconds

Return Format

<NR3>

The query command returns the output watchdog delay time. The reading is in the form +n.nnnnnnE+nn.

Example

The following command sets an output watchdog delay of 600 seconds.

```
OUTP:PROT:WDOG:DEL 600
```

The following query returns the maximum allowable output watchdog delay.

```
OUTP:PROT:WDOG:DEL? MAX
```

Typical Response: +3.600000+E3

See Also

[OUTPut:PROTection:WDOG\[:STATe\]](#)

OUTPut:RELAy:POLarity

Syntax

```
OUTPut:RELAy:POLarity <polarity>, (@<chanlist>)
```

```
OUTPut:RELAy:POLarity? (@<chanlist>)
```

Description

This command sets the output polarity on power modules with polarity reversal relays installed (Option 760). Polarity reversal affects both the output and the sense terminals.

NORMal Causes the output polarity to be the **same** as the output connector labeling.

REVerse Causes the output polarity to be the **reverse** of the output connector labeling. This command briefly turns the output off while the output and sense terminal polarities are switched.

NOTE

When installed on models N6742B and N6773A, Option 760 (Polarity Reversal) will limit the output current of these models to a maximum of 10 A. Option 760 is not available on models N6741B, N6751A, N6752A, N676xA, or N678xA SMU.

Parameters

Name	Type	Range of Values	Default Value
<polarity>	CPD	NORMal REVerse	NORMal
<chanlist>	Numeric	One or more channels. (@2) - channel 2 (@1,4) - channels 1 and 4 (@1:3) - channels 1 through 3.	Required parameter

Return Format

```
<CRD>
```

The query command returns NORM or REV.

Example

The following command sets the output polarity of channel 1 to REVerse.

```
OUTP:REL:POL REV, (@1)
```

The following query returns the setting of the output polarity of channel 2.

```
OUTP:REL:POL? (@2)
```

Typical Response: NORM

See Also

[OUTPut\[:STATe\]](#)

SENSe Subsystem Introduction

Sense commands control the current measurement range, the bandwidth detector of the instrument, and the data acquisition sequence.

SCPI Command	Description
SENSe	
:CURRent	
:CCOMpensate <Bool>, (@chanlist)	Enables/disables the capacitive current compensation
[:DC]:RANGe	
[:UPPer] <NRf+>, (@chanlist)	Selects the current measurement range
:AUTO <Bool>, (@chanlist)	Enables/disables measurement autoranging (N6781A, N6782A)
:ELOG	
:CURRent	
[:DC]:RANGe	
[:UPPer] <NRf+>, (@chanlist)	Sets the external data log current range
:AUTO <Bool>, (@chanlist)	Enables/disables measurement autoranging (N6781A, N6782A)
:FUNction	
:CURRent <Bool>, (@chanlist)	Enables/disables external current data logging
:MINMax <Bool>, (@chanlist)	Enables/disables external min/max current data logging
:VOLTage <Bool>, (@chanlist)	Enables/disables external voltage data logging
:MINMax <Bool>, (@chanlist)	Enables/disables external min/max voltage data logging
:PERiod <NR1>, (@chanlist)	Sets the integration time of the external data logging
:VOLTage	
[:DC]:RANGe	
[:UPPer] <NRf+>, (@chanlist)	Sets the external data log voltage range
:AUTO <Bool>, (@chanlist)	Enables/disables measurement autoranging (N6781A, N6782A)
:FUNction "VOLTage" "CURRent" "NONE", (@chanlist)	Selects the measurement function (for backward compatibility)
:CURRent <Bool>, (@chanlist)	Enables/disables current measurements (replaces FUNction)
:VOLTage <Bool>, (@chanlist)	Enables/disables voltage measurements (replaces FUNction)
:INPut MAIN AUXiliary, (@chanlist)	Selects the voltage measurement input (only on N6781A) (Sweep commands only on N676xA, N678xA SMU and Option 054)
:SWEEP	
:OFFSet	
:POINts <NRf+>, (@chanlist)	Defines the trigger offset in the measurement sweep
:POINts <NRf+>, (@chanlist)	Defines the number of data points in the measurement
:TINterval <NRf+>, (@chanlist)	Sets the measurement sample interval
:RESolution RES20 RES40, (@chanlist)	Sets the measurement sample interval
:VOLTage	
[:DC]:RANGe	
[:UPPer] <NRf+>, (@chanlist)	Selects the voltage measurement range
:AUTO <Bool>, (@chanlist)	Enables/disables measurement autoranging (N6781A, N6782A)
:WINDow	
[:TYPE] HANNing RECTangular, (@chanlist)	Selects measurement window (N676xA, N678xA SMU, Option 054)

SENSe:CURRent[:DC]:RANGe[:UPPer]**Syntax**

```
SENSe:CURRent[:DC]:RANGe[:UPPer] <range> ,
(@<chanlist>)
```

```
SENSe:CURRent[:DC]:RANGe[:UPPer]? [MIN|MAX, ]
(@<chanlist>)
```

Description

This command selects a DC current measurement range on models that have multiple ranges. The value that you enter must be higher than the maximum current that you expect to measure. Units are in amperes. The instrument selects the range with the best resolution for the value entered. MIN selects the lowest range; MAX selects the highest range.

When queried, the returned value is the maximum DC current that can be measured on the range that is presently set.

Parameters

Name	Type	Range of Values	Default Value
<range>	NRf+	0 - maximum MIN MAX Values entered are model dependent.	MAX
<chanlist>	Numeric	One or more channels. (@2) - channel 2 (@1,4) - channels 1 and 4 (@1:3) - channels 1 through 3.	Required parameter

Return Format

```
<NR3>
```

The query command returns the range in the form +n.nnnnnnE+nn for each channel specified. Multiple responses are separated by commas.

Examples

The following command selects the 100 mA range on channel 3.

```
SENSe:CURR:RANG 0.1, (@3)
```

The following query returns the range selected on channel 3.

```
SENSe:CURR:RANG? (@3)
```

Typical Response: +1.000000E-01

See Also

[SENSe:VOLTage\[:DC\]:RANGe](#)

SENSe:CURRent[:DC]:RANGe:AUTO**Syntax**

```
SENSe:CURRent[:DC]:RANGe:AUTO <Bool>, (@<chanlist>)
```

```
SENSe:CURRent[:DC]:RANGe:AUTO? (@<chanlist>)
```

Description

This command enables/disables current measurement autoranging. Autoranging provides seamless measurement ranging, which results in a wide dynamic range with no data being lost across ranges. Autoranging does not include the 10 μ A range, which must be selected individually.

When enabled, this command overrides the [SENSe:CURRent\[:DC\]:RANGe](#) setting.

NOTE

This command only applies to models N6781A, N6782A.

Parameters

Name	Type	Range of Values	Default Value
<bool>	Boolean	OFF 0 ON 1	OFF
<chanlist>	Numeric	One or more channels. (@2) - channel 2 (@1,4) - channels 1 and 4 (@1:3) - channels 1 through 3.	Required parameter

Return Format

```
<NR1>
```

The query command returns 0 if current measurement autoranging is OFF, and 1 if current measurement autoranging is ON.

Examples

The following command turns current measurement autoranging ON for channel 2.

```
SENS:CURR:RANG:AUTO ON, (@2)
```

The following query returns the current measurement autorange setting of channel 1.

```
SENS:CURR:RANG:AUTO? (@1)
```

Typical Response: 0

See Also

[SENSe:CURRent\[:DC\]:RANGe](#)

SENSe:CURRent:CCOMpensate

Syntax

```
SENSe:CURRent:CCOMpensate <Bool>, (@<chanlist>)
```

```
SENSe:CURRent:CCOMpensate? (@<chanlist>)
```

Description

This command turns current measurement compensation ON or OFF on the specified output channel.

When turned ON, this function corrects the output current measurement for the current that flows into the output capacitor. This current is only significant when high dv/dt occurs, and because this current does not flow into the output load, it represents an error when not corrected. Note that turning on the current measurement compensation increases the peak to peak noise in current measurements.

NOTE

This command does not apply to Models N678xA SMU.

On Models N676xA this command only applies in the High current range.

On Models N6751A/N6752A this command requires Option LGA to be installed.

Parameters

Name	Type	Range of Values	Default Value
<bool>	Boolean	OFF 0 ON 1	OFF
<chanlist>	Numeric	One or more channels. (@2) - channel 2 (@1,4) - channels 1 and 4 (@1:3) - channels 1 through 3.	Required parameter

Return Format

```
<NR1>
```

The query command returns 0 if current measurement compensation is OFF, and 1 if current measurement compensation is ON.

Examples

The following command turns current measurement compensation ON for output channel 2.

```
SENS:CURR:CCOM ON, (@2)
```

The following query returns the current measurement compensation setting of channel 1.

```
SENS:CURR:CCOM? (@1)
```

Typical Response: 0

SENSe:ELOG:CURRent[:DC]:RANGe[:UPPer]**Syntax**

```
SENSe:ELOG:CURRent[:DC]:RANGe[:UPPer] <range>,
(@<chanlist>)
```

```
SENSe:ELOG:CURRent[:DC]:RANGe[:UPPer]? [MIN|MAX, ]
(@<chanlist>)
```

Description

This command selects the external datalog current measurement range on models that have multiple ranges. The value that you enter must be the highest value in amperes that you expect to measure.

The instrument selects the best range that can be used to make this measurement. MIN selects the lowest range; MAX selects the highest range.

When queried, the returned value is the maximum current that can be measured on the range that is presently set.

Parameters

Name	Type	Range of Values	Default Value
<range>	NRf+	0 - maximum MIN MAX Values entered are model dependent.	MAX
<chanlist>	Numeric	One or more channels. (@2) - channel 2 (@1,4) - channels 1 and 4 (@1:3) - channels 1 through 3.	Required parameter

Return Format

```
<NR3>
```

The query command returns the range in the form +n.nnnnnnE+nn for each channel specified. Multiple responses are separated by commas.

Examples

The following command selects the 100 mA range on channel 3.

```
SENSe:ELOG:CURR:RANG 0.1, (@3)
```

The following query returns the range selected on channel 3.

```
SENSe:ELOG:CURR:RANG? (@3)
```

Typical Response: +1.000000E-01

See Also

[SENSe:ELOG:VOLTage:RANGe](#)

SENSe:ELOG:CURRent[:DC]:RANGe:AUTO**Syntax**

```
SENSe:ELOG:CURRent[:DC]:RANGe:AUTO <Bool> ,
(@<chanlist>)
```

```
SENSe:ELOG:CURRent[:DC]:RANGe:AUTO? (@<chanlist>)
```

Description

This command enables/disables the external datalog current measurement autoranging. Autoranging provides seamless measurement ranging, which results in a wide dynamic range with no data being lost across ranges. Autoranging does not include the 10 μ A range, which must be selected individually.

When enabled, this command overrides the [SENSe:ELOG:CURRent:RANGe](#) setting.

NOTE

This command only applies to models N6781A, N6782A.

Parameters

Name	Type	Range of Values	Default Value
<bool>	Boolean	OFF 0 ON 1	OFF
<chanlist>	Numeric	One or more channels. (@2) - channel 2 (@1,4) - channels 1 and 4 (@1:3) - channels 1 through 3.	Required parameter

Return Format

```
<NR1>
```

The query command returns 0 if current data logging autoranging is OFF, and 1 if current data logging autoranging is ON.

Examples

The following command turns external current data logging autoranging ON for channel 2.

```
SENSe:ELOG:CURR:RANG:AUTO ON, (@2)
```

The following query returns the external current data logging autorange setting of channel 1.

```
SENSe:ELOG:CURR:RANG:AUTO? (@1)
```

Typical Response: 0

See Also

[SENSe:ELOG:CURRent:RANGe](#)

SENSe:ELOG:FUNction:CURRent

Syntax

```
SENSe:ELOG:FUNction:CURRent <Bool>, (@<chanlist>)
```

```
SENSe:ELOG:FUNction:CURRent? (@<chanlist>)
```

Description

This command turns external current data logging ON or OFF on the specified output channel.

Parameters

Name	Type	Range of Values	Default Value
<bool>	Boolean	OFF 0 ON 1	OFF
<chanlist>	Numeric	One or more channels. (@2) - channel 2 (@1,4) - channels 1 and 4 (@1:3) - channels 1 through 3.	Required parameter

Return Format

```
<NR1>
```

The query command returns 0 if external current data logging is OFF, and 1 if current data logging is ON.

Examples

The following command turns external current data logging ON for output channel 2.

```
SENSe:ELOG:FUNc:CURR ON, (@2)
```

The following query returns the external current data logging setting of channel 1.

```
SENSe:ELOG:FUNc:CURR? (@1)
```

Typical Response: 0

SENSe:ELOG:FUNction:CURRent:MINMax

Syntax

```
SENSe:ELOG:FUNction:CURRent:MINMax <Bool> ,
(@<chanlist>)
```

```
SENSe:ELOG:FUNction:CURRent:MINMax? (@<chanlist>)
```

Description

This command turns external current data logging of the minimum and maximum current measurements ON or OFF on the specified output channel.

Parameters

Name	Type	Range of Values	Default Value
<bool>	Boolean	OFF 0 ON 1	OFF
<chanlist>	Numeric	One or more channels. (@2) - channel 2 (@1,4) - channels 1 and 4 (@1:3) - channels 1 through 3.	Required parameter

Return Format

```
<NR1>
```

The query command returns 0 if external minimum and maximum current measurements is OFF, and 1 if minimum and maximum current measurements is ON.

Examples

The following command turns external minimum and maximum current measurements ON for output channel 2.

```
SENSe:ELOG:FUNction:CURRent:MINMax ON, (@2)
```

The following query returns the external minimum and maximum current measurements setting of channel 1.

```
SENSe:ELOG:FUNction:CURRent:MINMax? (@1)
```

Typical Response: 0

SENSe:ELOG:FUNction:VOLTage

Syntax

```
SENSe:ELOG:FUNction:VOLTage <Bool>, (@<chanlist>)
```

```
SENSe:ELOG:FUNction:VOLTage? (@<chanlist>)
```

Description

This command turns external voltage data logging ON or OFF on the specified output channel.

Parameters

Name	Type	Range of Values	Default Value
<bool>	Boolean	OFF 0 ON 1	ON
<chanlist>	Numeric	One or more channels. (@2) - channel 2 (@1,4) - channels 1 and 4 (@1:3) - channels 1 through 3.	Required parameter

Return Format

```
<NR1>
```

The query command returns 0 if external voltage data logging is OFF, and 1 if voltage data logging is ON.

Examples

The following command turns external voltage data logging ON for output channel 2.

```
SENSe:ELOG:FUNc:VOLT ON, (@2)
```

The following query returns the external voltage data logging setting of channel 1.

```
SENSe:ELOG:FUNc:VOLT? (@1)
```

Typical Response: 0

SENSe:ELOG:FUNction:VOLTage:MINMax

Syntax

```
SENSe:ELOG:FUNction:VOLTage:MINMax <Bool>,  
(@<chanlist>)
```

```
SENSe:ELOG:FUNction:VOLTage:MINMax? (@<chanlist>)
```

Description

This command turns external voltage data logging of the minimum and maximum voltage measurements ON or OFF on the specified output channel.

Parameters

Name	Type	Range of Values	Default Value
<bool>	Boolean	OFF 0 ON 1	OFF
<chanlist>	Numeric	One or more channels. (@2) - channel 2 (@1,4) - channels 1 and 4 (@1:3) - channels 1 through 3.	Required parameter

Return Format

```
<NR1>
```

The query command returns 0 if external minimum and maximum voltage measurements is OFF, and 1 if minimum and maximum voltage measurements is ON.

Examples

The following command turns external minimum and maximum voltage measurements ON for output channel 2.

```
SENSe:ELOG:FUNction:VOLTage:MINMax ON, (@2)
```

The following query returns the external minimum and maximum voltage measurements setting of channel 1.

```
SENSe:ELOG:FUNction:VOLTage:MINMax? (@1)
```

Typical Response: 0

SENSe:ELOG:PERiod

Syntax

```
SENSe:ELOG:PERiod <seconds>, (@<chanlist>)
SENSe:ELOG:PERiod? [MIN|MAX,] (@<chanlist>)
```

Description

This command sets the logging period (or integration) time of an external datalog measurement. Datalog measurement records are generated at the rate determined by this time interval.

Although the absolute minimum logging period is 102.4 microseconds, the actual minimum varies as a function of the number of channels and readings that are being logged. The limiting factor is the speed at which data can be fetched from the FIFO buffer. The actual minimum is (102.4 microseconds x number of parameters being logged at each interval). So for example if average voltage, minimum voltage, maximum voltage, and average current are being logged for a single channel, the minimum logging period is (4 parameters X 102.4) = 409.6 microseconds.

The logging period resolution can be set to either 20.48 microseconds or 40.96 microseconds by the [SENSe:SWEep:TINterval:RESolution](#) command. The 20-microsecond resolution allows up to 4 parameters to be logged. The 40-microsecond resolution allows up to 8 parameters to be logged.

Parameters

Name	Type	Range of Values	Default Value
<seconds>	Nrf+	0.0001024 to 60 MIN MAX	0.1
<chanlist>	Numeric	One or more channels. (@2) - channel 2 (@1,4) - channels 1 and 4 (@1:3) - channels 1 through 3.	Required parameter

Return Format

```
<NR1>
```

The query command returns the external datalog period in seconds.

Examples

The following command specifies an external datalog period of 0.01 seconds for channel 1.

```
SENS:ELOG:PER 0.01, (@1)
```

The following query returns the external datalog period from channel 1.

```
SENS:ELOG:PER? (@1)
```

Typical Response: 0.01

See Also

[SENSe:SWEp:TINterval:RESolution](#)

SENSe:ELOG:VOLTage[:DC]:RANGe[:UPPer]**Syntax**

```
SENSe:ELOG:VOLTage[:DC]:RANGe[:UPPer] <range>,
(@<chanlist>)
```

```
SENSe:ELOG:VOLTage[:DC]:RANGe[:UPPer]? [MIN|MAX, ]
(@<chanlist>)
```

Description

This command selects the external datalog voltage measurement range on models that have multiple ranges. The value that you enter must be the highest value in volts that you expect to measure. The instrument selects the best range that can be used to make this measurement. MIN selects the lowest range; MAX selects the highest range.

When queried, the returned value is the maximum voltage that can be measured on the range that is presently set.

Parameters

Name	Type	Range of Values	Default Value
<range>	NRf+	0 - maximum MIN MAX Values entered are model dependent.	MAX
<chanlist>	Numeric	One or more channels. (@2) - channel 2 (@1,4) - channels 1 and 4 (@1:3) - channels 1 through 3.	Required parameter

Return Format

```
<NR3>
```

The query command returns the range in the form +n.nnnnnnE+nn for each channel specified. Multiple responses are separated by commas.

Examples

The following command selects the 5 V range on channel 3.

```
SENSe:ELOG:VOLT:RANG 5,(@3)
```

The following query returns the range selected on channel 1.

```
SENSe:ELOG:VOLT:RANG? (@1)
```

Typical Response: +5.500000E+01

See Also

[SENSe:ELOG:CURRent:RANGe](#)

SENSe:ELOG:VOLTage[:DC]:RANGe:AUTO

Syntax

```
SENSe:ELOG:VOLTage[:DC]:RANGe:AUTO <Bool> ,
(@<chanlist>)
```

```
SENSe:ELOG:VOLTage[:DC]:RANGe:AUTO? (@<chanlist>)
```

Description

This command enables/disables the external datalog voltage measurement autoranging. Autoranging provides seamless measurement ranging, which results in a wide dynamic range with no data being lost across ranges.

When enabled, this command overrides the [SENSe:ELOG:VOLTage:RANGe](#) setting.

NOTE

This command only applies to models N6781A, N6782A.

Parameters

Name	Type	Range of Values	Default Value
<bool>	Boolean	OFF 0 ON 1	OFF
<chanlist>	Numeric	One or more channels. (@2) - channel 2 (@1,4) - channels 1 and 4 (@1:3) - channels 1 through 3.	Required parameter

Return Format

```
<NR1>
```

The query command returns 0 if voltage data logging autoranging is OFF, and 1 if voltage data logging autoranging is ON.

Examples

The following command turns external voltage data logging autoranging ON for channel 2.

```
SENSe:ELOG:VOLT:RANG:AUTO ON, (@2)
```

The following query returns the external voltage data logging autorange setting of channel 1.

```
SENSe:ELOG:VOLT:RANG:AUTO? (@1)
```

Typical Response: 0

See Also

[SENSe:ELOG:VOLTage:RANGe](#)

SENSe:FUNction

Syntax

```
SENSe:FUNction <"function">, (@<chanlist>)
```

```
SENSe:FUNction? (@<chanlist>)
```

Description

This command selects a measurement function on models that do not have simultaneous voltage and current measurement capability. This command is required so that the acquisition system knows which measurement function to acquire when a measurement is triggered. Selecting NONE disables the measurement function.

NOTE

This command has been superseded by the [SENSe:FUNction:CURRent](#) and [SENSe:FUNction:VOLTage](#) commands, which should be used in new applications. SENSe:FUNction is still available for backward compatibility.

Parameters

Name	Type	Range of Values	Default Value
<"function">	SPD	"CURRent" "VOLTage" "NONE" Parameters must be enclosed in single or double quotes	VOLTage
<chanlist>	Numeric	One or more channels. (@2) - channel 2 (@1,4) - channels 1 and 4 (@1:3) - channels 1 through 3.	Required parameter

Return Format

```
<SRD>
```

The query command returns an ASCII string enclosed in double quotes for each channel specified. Multiple responses are separated by commas. The short form of the parameter is always returned.

Examples

The following command selects the voltage function on channel 3.

```
SENS:FUNC "VOLT", (@3)
```

The following query returns the function selected on channel 1 (quotes are also returned).

```
SENS:FUNC? (@1)
```

Typical Response: "VOLT"

SENSe:FUNcTion:CURRent

Syntax

```
SENSe:FUNcTion:CURRent <Bool>, (@<chanlist>)
```

```
SENSe:FUNcTion:CURRent? (@<chanlist>)
```

Description

This command enables or disables the current measurement function for triggered data acquisitions. It applies to all models, including those that have simultaneous voltage and current measurement capability. On modules with simultaneous measurement capability, you can enable BOTH current and voltage measurements (see [SENSe:FUNcTion:VOLTagE](#)).

NOTE

This command replaces the previous [SENSe:FUNcTion](#) command and should be used in new applications. SENSe:FUNcTion is still available for backward compatibility.

Parameters

Name	Type	Range of Values	Default Value
<bool>	Boolean	OFF 0 ON 1	OFF
<chanlist>	Numeric	One or more channels. (@2) - channel 2 (@1,4) - channels 1 and 4 (@1:3) - channels 1 through 3.	Required parameter

Return Format

```
<NR1>
```

The query command returns 0 if the current measurements are disabled, and 1 if current measurements are enabled.

Examples

The following command enables current measurements on channel 3.

```
SENSe:FUNcTion:CURRent ON, (@3)
```

The following query returns the current measurement state of channel 3.

```
SENSe:FUNcTion:CURRent? (@3)
```

Typical Response: 1

See Also

[SENSe:FUNcTion:VOLTagE](#)

SENSe:FUNcTion:VOLTage

Syntax

```
SENSe:FUNcTion:VOLTage <Bool>, (@<chanlist>)
```

```
SENSe:FUNcTion:VOLTage? (@<chanlist>)
```

Description

This command enables or disables the voltage measurement function for triggered data acquisitions. It applies to all models, including those that have simultaneous voltage and current measurement capability. On modules with simultaneous measurement capability, you can enable BOTH current and voltage measurements (see [SENSe:FUNcTion:CURRent](#)).

NOTE

This command replaces the previous [SENSe:FUNcTion](#) command and should be used in new applications. SENSe:FUNcTion is still available for backward compatibility.

Parameters

Name	Type	Range of Values	Default Value
<bool>	Boolean	OFF 0 ON 1	OFF
<chanlist>	Numeric	One or more channels. (@2) - channel 2 (@1,4) - channels 1 and 4 (@1:3) - channels 1 through 3.	Required parameter

Return Format

```
<NR1>
```

The query command returns 0 if the voltage measurements are disabled, and 1 if voltage measurements are enabled.

Examples

The following command enables voltage measurements on channel 3.

```
SENSe:FUNcTion:VOLT ON, (@3)
```

The following query returns the voltage measurement state of channel 3.

```
SENSe:FUNcTion:VOLT? (@3)
```

Typical Response: 1

See Also

[SENSe:FUNcTion:CURRent](#)

SENSe:FUNcTion:VOLTage:INPut

Syntax

```
SENSe:FUNcTion:VOLTage:INPut <input>, (@<chanlist>)
```

```
SENSe:FUNcTion:VOLTage:INPut? (@<chanlist>)
```

Description

This command selects the voltage measurement input on models that have an auxiliary voltage measurement input. Selecting MAIN selects the front panel binding posts as the measurement inputs. Selecting AUXiliary selects the rear panel auxiliary voltage inputs as the measurement inputs.

NOTE

This command only applies to model N6781A, which has auxiliary voltage measurement capability.

Parameters

Name	Type	Range of Values	Default Value
<input>	CPD	MAIN AUXiliary	MAIN
<chanlist>	Numeric	One or more channels. (@2) - channel 2 (@1,4) - channels 1 and 4 (@1:3) - channels 1 through 3.	Required parameter

Return Format

```
<SRD>
```

The query command returns an ASCII string for each channel specified. Multiple responses are separated by commas. The short form of the parameter is always returned.

Examples

The following command selects the auxiliary voltage input on channel 3.

```
SENS:FUNC:VOLT:INP AUX, (@3)
```

The following query returns the function selected on channel 1.

```
SENS:FUNC:VOLT:INP? (@1)
```

Typical Response: MAIN

SENSe:SWEep:OFFSet:POINts

Syntax

```
SENSe:SWEep:OFFSet:POINts <points>, (@<chanlist>)
```

```
SENSe:SWEep:OFFSet:POINts? [MIN|MAX,] (@<chanlist>)
```

Description

This command defines the offset in a data sweep when the measurement is triggered on modules that have measurement controls. Programmed values can range from --(SENSe:SWE:POIN setting -1) through 2,000,000,000 (2E9). Positive values represent the delay after the trigger occurs but before the samples are acquired. Negative values represent data samples taken prior to the trigger. The maximum negative value that can be programmed is one less than the maximum allowable [SENSe:SWEep:POINts](#) value.

NOTE

This command is used only with models N676xA, N678xA SMU, or models that have Option 054 (High Speed Test Extensions).

Parameters

Name	Type	Range of Values	Default Value
<points>	NRf+	-524,287 - 2,000,000,000 MIN MAX	0
<chanlist>	Numeric	One or more channels. (@2) - channel 2 (@1,4) - channels 1 and 4 (@1:3) - channels 1 through 3.	Required parameter

Return Format

```
<NR3>
```

The query command returns the number of offset points for each channel specified. Multiple responses are separated by commas.

Examples

The following command specifies -2048 offset points on channel 3.

```
SENSe:SWE:OFFS:POIN -2048, (@3)
```

The following query returns the number of offset points specified for channel 1.

```
SENSe:SWE:OFFS:POIN? (@1)
```

Typical Response: +0

See Also

[SENSe:SWEep:POINts](#)

[SENSe:SWEep:TINterval](#)

SENSe:SWEep:POINts

Syntax

```
SENSe:SWEep:POINts <points>, (@<chanlist>)
```

```
SENSe:SWEep:POINts? [MIN|MAX,] (@<chanlist>)
```

Description

This command defines the number of points in a measurement. The number of samples (points) that can be specified depends on the number of measurement parameters selected. You can measure up to eight parameters (voltage and current X 4 outputs).

1 parameter: up to 512 K points

2 parameters: up to 256 K points

3 parameters: up to 128 K points

4 parameters: up to 64 K points

(K = 1024)

NOTE

This command is used only with models N676xA, N678xA SMU, or models that have Option 054 (High Speed Test Extensions).

Parameters

Name	Type	Range of Values	Default Value
<points>	NRf+	1 – 512 K* MIN MAX (*for 1 measurement parameter)	N678xA SMU: 4883 All other modules: 1024
<chanlist>	Numeric	One or more channels. (@2) - channel 2 (@1,4) - channels 1 and 4 (@1:3) - channels 1 through 3.	Required parameter

Return Format

```
<NR1>
```

The query command returns the number of points for each channel specified. Multiple responses are separated by commas.

Examples

The following command specifies 2048 measurement points on channel 3.

```
SENS:SWE:POIN 2048, (@3)
```

The following query returns the number of points specified for channel 1.

```
SENS:SWE:POIN? (@1)
```

Typical Response: +1024

See Also

[SENSe:SWEep:OFFSet:POINTs](#)

[SENSe:SWEep:TINTerval](#)

SENSe:SWEep:TINterval

Syntax

```
SENSe:SWEep:TINterval <interval>, (@<chanlist>)
```

```
SENSe:SWEep:TINterval? [MIN|MAX,] (@<chanlist>)
```

Description

This command defines the time period between samples in seconds on models that have measurement controls. Programmed values can range from 5.12 microseconds (for one measurement parameter on Models N678xA SMU) to 40,000 seconds. Note that the shortest time interval (fastest speed) that can be specified depends on the number of parameters that are being measured and the model that is doing the measuring. Values above 10.24 microseconds are rounded to the nearest 10.24-microsecond increment. Values above 20.48 microseconds are rounded to the nearest 20.48-microsecond increment.

5.12 microseconds: 1 parameter on Models N678xA only

10.24 microseconds: 1 or 2 parameters on all models

20.48 microseconds: 3 or 4 parameters on all models

NOTE

This command is used only with models N676xA, N678xA SMU, or models that have Option 054 (High Speed Test Extensions).

Parameters

Name	Type	Range of Values	Default Value
<interval>	NRf+	0.00000512 – 40,000 MIN MAX	0.00002048 seconds
<chanlist>	Numeric	One or more channels. (@2) - channel 2 (@1,4) - channels 1 and 4 (@1:3) - channels 1 through 3.	Required parameter

Return Format

```
<NR3>
```

The query command returns the time interval for each channel specified. The value returned is the time period rounded to the nearest 20.48 microsecond increment; which is not necessarily the value that was programmed. Multiple responses are separated by commas.

Examples

The following command specifies a time interval of 1 second between measurement points on channel 3.

```
SENS:SWE:TINT 1, (@3)
```

3 Commands by Subsystem

The following query returns the measurement time interval for channel 1.

```
SENS:SWE:TINT? (@1)
```

Typical Response: +2.048000E-5

See Also

[SENSe:SWEp:OFFSet:POINts](#)

[SENSe:SWEp:POINts](#)

SENSe:SWEep:TINTerval:RESolution

Syntax

```
SENSe:SWEep:TINTerval:RESolution <resolution>,
(@<chanlist>)

SENSe:SWEep:TINTerval:RESolution? (@<chanlist>)
```

Description

This command sets the resolution used in setting the time interval between digitized measurements for time intervals above 20.48 microseconds. Note that external data log measurements also use this resolution setting. The following resolutions may be specified:

RES20: rounds all values above 20.48 microseconds to the nearest multiple of 20.48 microseconds

RES40: rounds all values above 20.48 microseconds to the nearest multiple of 40.96 microseconds

NOTE

This command is used only with models N676xA, N678xA SMU, or models that have Option 054 (High Speed Test Extensions).

Parameters

Name	Type	Range of Values	Default Value
<resolution>	CPD	RES20 RES40	0.00002048 seconds
<chanlist>	Numeric	One or more channels. (@2) - channel 2 (@1,4) - channels 1 and 4 (@1:3) - channels 1 through 3.	Required parameter

Return Format

<NR3>

The query command returns the resolution for each channel specified.. Multiple responses are separated by commas.

Examples

The following command specifies a measurement resolution of 40 microseconds on channel 3.

```
SENSe:SWEep:TINT:RES RES40, (@3)
```

The following query returns the measurement resolution for channel 1.

```
SENSe:SWEep:TINT:RES? (@1)
```

Typical Response: RES20

See Also

[SENSe:SWEp:TINterval](#)

[SENSe:ELOG:PERiod](#)

SENSe:VOLTage[:DC]:RANGe[:UPPer]**Syntax**

```
SENSe:VOLTage[:DC]:RANGe[:UPPer] <range>,
(@<chanlist>)
```

```
SENSe:VOLTage[:DC]:RANGe[:UPPer]? [MIN|MAX, ]
(@<chanlist>)
```

Description

This command selects a DC voltage measurement range on models that have multiple ranges. The programmed value must be the maximum voltage that you expect to measure. Units are in volts. The instrument selects the range with the best resolution for the value entered. MIN selects the lowest range; MAX selects the highest range.

When queried, the returned value is the maximum DC voltage that can be measured on the range that is presently set.

Parameters

Name	Type	Range of Values	Default Value
<range>	NRf+	0 - maximum MIN MAX Values entered are model dependent.	MAX
<chanlist>	Numeric	One or more channels. (@2) - channel 2 (@1,4) - channels 1 and 4 (@1:3) - channels 1 through 3.	Required parameter

Return Format

```
<NR3>
```

The query command returns the range in the form +n.nnnnnnE+nn for each channel specified. Multiple responses are separated by commas.

Examples

The following command selects the 5 V range on channel 3.

```
SENS:VOLT:RANG 5,(@3)
```

The following query returns the range selected on channel 1.

```
SENS:VOLT:RANG? (@1)
```

Typical Response: +5.500000E+01

See Also

[SENSe:CURRent\[:DC\]:RANGe](#)

SENSe:VOLTage[:DC]:RANGe:AUTO**Syntax**

```
SENSe:VOLTage[:DC]:RANGe:AUTO <Bool>, (@<chanlist>)
```

```
SENSe:VOLTage[:DC]:RANGe:AUTO? (@<chanlist>)
```

Description

This command enables/disables voltage measurement autoranging. Autoranging provides seamless measurement ranging, which results in a wide dynamic range with no data being lost across ranges.

When enabled, this command overrides the [SENSe:VOLTage\[:DC\]:RANGe](#) setting.

NOTE

This command only applies to models N6781A, N6782A.

Parameters

Name	Type	Range of Values	Default Value
<bool>	Boolean	OFF 0 ON 1	OFF
<chanlist>	Numeric	One or more channels. (@2) - channel 2 (@1,4) - channels 1 and 4 (@1:3) - channels 1 through 3.	Required parameter

Return Format

```
<NR1>
```

The query command returns 0 if voltage measurement autoranging is OFF, and 1 if voltage measurement autoranging is ON.

Examples

The following command turns voltage measurement autoranging ON for channel 2.

```
SENS:VOLT:RANG:AUTO ON, (@2)
```

The following query returns the voltage measurement autorange setting of channel 1.

```
SENS:VOLT:RANG:AUTO? (@1)
```

Typical Response: 0

See Also

[SENSe:VOLTage\[:DC\]:RANGe](#)

SENSe:WINDow[:TYPE]

Syntax

SENSe:WINDow[:TYPE] <window>, (@<chanlist>)

SENSe:WINDow[:TYPE]? (@<chanlist>)

Description

This command sets a signal conditioning function used in DC measurement calculations on models that have measurement controls. Select from the following filter window types:

HANNing The Hanning window is a "raised cosine" function. It is a signal conditioning function that reduces errors in DC measurement calculations in the presence of periodic signals such as AC line ripple.

RECTangular A window that returns measurement calculations with no signal conditioning.

Note that neither window function alters the instantaneous voltage or current data returned in the measurement array.

NOTE

This command is used only with models N676xA, N678xA SMU, or models that have Option 054 (High Speed Test Extensions).

Parameters

Name	Type	Range of Values	Default Value
<window>	CPD	HANNing RECTangular	RECTangular
<chanlist>	Numeric	One or more channels. (@2) - channel 2 (@1,4) - channels 1 and 4 (@1:3) - channels 1 through 3.	Required parameter

Return Format

<CRD>

The query command returns the window setting for each channel specified. Multiple responses are separated by commas.

Examples

The following command specifies a RECTangular measurement window for channel 3.

```
SENS:WIND RECT, (@3)
```

The following query returns the measurement window for channel 1.

```
SENS:WIND? (@1)
```

Typical Response: RECT

SOURce Subsystem Introduction

The Source subsystem programs the current, digital, list, step, and voltage functions.

SCPI Command	Description
[SOURce:]	
CURRent	
[:LEVel]	
[:IMMEDIATE][:AMPLitude] <NRf+>, (@chanlist)	Sets the output current
:TRIGgered [:AMPLitude] <NRf+>, (@chanlist)	Sets the triggered output current
:LIMit	
[:POSitive]	
[:IMMEDIATE][:AMPLitude] <NRf+>, (@chanlist)	Sets the positive current limit (only on N678xA SMU, N6783A)
:COUPle <Bool>, (@chanlist)	Sets the current limit tracking state (only on N678xA SMU)
:NEGative	
[:IMMEDIATE][:AMPLitude] <NRf+>, (@chanlist)	Sets the negative current limit (only N678xA SMU, N6783A-BAT)
:MODE FIXed STEP LIST, (@chanlist)	Sets the current trigger mode
:PROTection	
:DELay	
[:TIME] <NRf+>, (@chanlist)	Sets the over-current protection programming delay
:STARt SCHange CCTRans, (@chanlist)	Sets the over-current protection programming mode
:STATe <Bool>, (@chanlist)	Enables/disables over-current protection on the selected output
:RANGe <NRf+>, (@chanlist)	Sets the output current range
:SLEW	
[:IMMEDIATE] <NRf+> INFIInity, (@chanlist)	Sets the output current slew rate (only N678xA SMU)
:MAXimum <Bool>, (@chanlist)	Enables/disables the maximum slew rate override (N678xA SMU)
DIGital	
:INPut:DATA?	Reads the state of the digital port pins
:OUTPut:DATA <NRf>	Sets the digital port
:PIN<1-7>	
:FUNctIon DIO DINPut TOUTput TINPut FAULt INHibit ONCOuple OFFCOuple	Sets the selected pin's function
:POLarity POSitive NEGative	Sets the selected pin's polarity
:TOUTput	
:BUS[:ENABle] <Bool>	Enables/disables BUS-generated triggers on digital pins
FUNCTION CURRent VOLTage, (@chanlist)	Specifies current priority or voltage priority mode (N678xA SMU)
LIST	(List commands only on N676xA, N678xA SMU and Option 054)
:COUNT <NRf+> INFIInity, (@chanlist)	Sets the list repeat count
:CURRent	
[:LEVel] <NRf> {,<NRf>}, (@chanlist)	Sets the current list
:POINts? (@chanlist)	Returns the number of current list points
:DWELI <NRf> {,<NRf>}, (@chanlist)	Sets the list of dwell times
:POINts? (@chanlist)	Returns the number of dwell list points
:STEP ONCE AUTO, (@chanlist)	Specifies how the list responds to triggers
:TERMinate	
:LAST <Bool>, (@chanlist)	Sets the list termination mode
:TOUTput	
:BOStep	
[:DATA] <Bool> {,<Bool>}, (@chanlist)	Generate triggers at the Beginning Of Step
:POINts? (@chanlist)	Returns the number of beginning of step list points

SCPI Command	Description
[SOURce:]LIST (continued)	
:EOStep [:DATA] <Bool> {,<Bool>}, (@chanlist) :POINts? (@chanlist)	Generate triggers at the End Of Step Returns the number of end of step list points
:VOLTage [:LEVel] <NRf> {,<NRf>}, (@chanlist) :POINts? (@chanlist)	Sets the voltage list Returns the number of voltage level points
POWer :LIMit <NRf+>, (@chanlist)	Sets the power limit on output channels
RESistance [:LEVel][:IMMEDIATE][:AMPLitude] <NRf+>, (@chanlist) :STATe <Bool>, (@chanlist)	Sets the output resistance (only on N6781A) Enables/disables output resistance programming (only N6781A)
STEP :TOUTput <Bool>, (@chanlist)	Generate a trigger output on the voltage or current step transient
VOLTage [:LEVel] [:IMMEDIATE][:AMPLitude] <NRf+>, (@chanlist) :TRIGgered[:AMPLitude] <NRf+>, (@chanlist) :BWIDth LOW HIGH1 HIGH2 HIGH3, (@chanlist) :LIMit [:POSitive] [:IMMEDIATE][:AMPLitude] <NRf+>, (@chanlist) :COUPle <Bool>, (@chanlist) :NEGative [:IMMEDIATE][:AMPLitude] <NRf+>, (@chanlist)	Sets the output voltage Sets the triggered output voltage Sets the voltage bandwidth (only on N678xA SMU) Sets the positive voltage limit (only on N678xA SMU) Sets the voltage limit tracking state (only on N6784A) Sets the negative voltage limit (only on N6784A)
:MODE FIXed STEP LIST, (@chanlist)	Sets the voltage trigger mode
:PROTection [:LEVel] <NRf+>, (@chanlist) :DELay[:TIME] <NRf+>, (@chanlist) :REMote [:POSitive][:LEVel] <NRf+>, (@chanlist) :NEGative[:LEVel] <NRf+>, (@chanlist)	Sets the over-voltage protection level Sets the over-voltage protection delay (only on N6783A) Sets the positive remote OV protection level (only on N678xA SMU) Sets the negative remote OV protection level (only on N6784A)
:TRACking [:STATe] <Bool>, (@chanlist) :OFFSet <NRf+>, (@chanlist)	(Tracking commands only on Option J01) Enables/disables tracking OVP Sets the tracking OVP offset
:RANGe <NRf+>, (@chanlist)	Sets the output voltage range
:SLEW [:IMMEDIATE] <NRf+> INFIinity, (@chanlist) :MAXimum <Bool>, (@chanlist)	Sets the output voltage slew rate Enables/disables the maximum slew rate override

[SOURce:]CURRent[:LEVel][:IMMediate][:AMPLitude]**Syntax**

```
[SOURce:]CURRent[:LEVel][:IMMediate][:AMPLitude]
<current>, (@<chanlist>)
```

```
[SOURce:]CURRent[:LEVel][:IMMediate][:AMPLitude]?
[MIN|MAX,] (@<chanlist>)
```

Description

This command sets the immediate current level of the specified output channel. Units are in amperes. The immediate level is the output current setting.

Parameters

Name	Type	Range of Values	Default Value
<current>	NRf+	0 - maximum MIN MAX The maximum value is dependent on the current rating of the power module.	80 mA
<chanlist>	Numeric	One or more channels. (@2) - channel 2 (@1,4) - channels 1 and 4 (@1:3) - channels 1 through 3.	Required parameter

Remarks

This command is coupled with [\[SOURce:\]CURRent:RANGe](#).

Return Format

```
<NR3>
```

The query command returns the programmed current level in the form +n.nnnnnnE+nn for each channel specified. Multiple responses are separated by commas.

Examples

The following command sets the output current to 3 A on channels 1 and 2.

```
CURR 3, (@1, 2)
```

The following query returns the programmed current level on channels 1 and 2.

```
CURR? (@1, 2)
```

Typical Response: +3.000000E+00, +3.000000E+00

See Also

[\[SOURCE:ICURRENT:RANGE](#)

[SOURce:]CURRent[:LEVel]:TRIGgered[:AMPLitude]**Syntax**

```
[SOURce:]CURRent[:LEVel]:TRIGgered[:AMPLitude]
<current>, (@<chanlist>)
```

```
[SOURce:]CURRent[:LEVel]:TRIGgered[:AMPLitude]?
[MIN|MAX,] (@<chanlist>)
```

Description

This command sets the triggered current level of the specified output channel. Units are in amperes. The triggered level is a stored value that is transferred to the output when an output Step is triggered.

Parameters

Name	Type	Range of Values	Default Value
<current>	NRf+	0 - maximum MIN MAX The maximum value is dependent on the current rating of the power module.	MIN
<chanlist>	Numeric	One or more channels. (@2) - channel 2 (@1,4) - channels 1 and 4 (@1:3) - channels 1 through 3.	Required parameter

Remarks

This command is coupled with [SOURce:]CURRent:RANGe.

Return Format

```
<NR3>
```

The query command returns the programmed triggered level in the form +n.nnnnnnE+nn for each channel specified. Multiple responses are separated by commas.

Examples

The following command sets the triggered current to 2 A on channels 1 and 2.

```
CURR:TRIG 2,(@1,2)
```

The following query returns the programmed triggered level on channels 1 and 2.

```
CURR:TRIG? (@1,2)
```

Typical Response: +2.000000E+00,+2.000000E+00

See Also

[\[SOURCE:|CURRENT\[:LEVEL\]\[:IMMEDIATE\]](#)

[\[SOURCE:|CURRENT:MODE](#)

[TRIGGER:TRANSIENT\[:IMMEDIATE\]](#)

[SOURce:]CURRent:LIMit[:POSitive][:IMMEDIATE][:AMPLitude]**Syntax**

```
[SOURce:]CURRent:LIMit[:POSitive][:IMMEDIATE]
[:AMPLitude] <limit>, (@<chanlist>)
```

```
[SOURce:]CURRent:LIMit[:POSitive][:IMMEDIATE]
[:AMPLitude]? [MIN|MAX,] (@<chanlist>)
```

Description

This command sets the positive current limit of the specified output channel. Units are in amperes. If [\[SOURce:\]CURRent:LIMit:COUPle](#) is enabled, this command also sets the value of the negative current limit. Refer to Appendix E in the N6700 User's Guide under "Voltage Priority" for more information about current limit operation.

NOTE

This command only applies to models N678xA SMU and N6783A.

Parameters

Name	Type	Range of Values	Default Value
<limit>	NRf+	0 - 3.06 MIN MAX	MAX (of selected range)
<chanlist>	Numeric	One or more channels. (@2) - channel 2 (@1,4) - channels 1 and 4 (@1:3) - channels 1 through 3.	Required parameter

Return Format

<NR3>

The query command returns the current limit in the form +n.nnnnnnE+nn for each channel specified. Multiple responses are separated by commas.

Examples

The following command sets the current limit to 3 A on channels 1 and 2.

```
CURR:LIM 3, (@1, 2)
```

The following query returns the current limit on channels 1 and 2.

```
CURR:LIM? (@1, 2)
```

Typical Response: +3.000000E+00, +3.000000E+00

See Also

[SOURce:]CURRent:LIMit:COUPle

[SOURce:]CURRent:LIMit:NEGative

[SOURce:]CURRent:LIMit:COUPle**Syntax**

```
[SOURce:]CURRent:LIMit:COUPle <Bool>, (@<chanlist>)
[SOURce:]CURRent:LIMit:COUPle? (@<chanlist>)
```

Description

This command sets the current limit tracking state. The enabled state is On (1); the disabled state is Off (0). If limit tracking is enabled, the negative current limit tracks the positive current limit setting. The [\[SOURce:\]CURRent:LIMit](#) command sets the value of the positive and negative current limits.

NOTE

This command only applies to models N678xA SMU.

Parameters

Name	Type	Range of Values	Default Value
<Bool>	Boolean	OFF 0 ON 1	OFF
<chanlist>	Numeric	One or more channels. (@2) - channel 2 (@1,4) - channels 1 and 4 (@1:3) - channels 1 through 3.	Required parameter

Return Format

```
<NR1>
```

The query command returns 1 if the current limit coupling is enabled, and 0 if the current limit coupling is disabled.

Examples

The following command sets the current limit coupling on for channel 4.

```
CURR:LIM:COUP ON, (@4)
```

The following query returns the current limit coupling state for channel 1.

```
CURR:LIM:COUP? (@1)
```

Typical Response: 0

See Also

[\[SOURce:\]CURRent:LIMit](#)

[\[SOURce:\]CURRent:LIMit:NEGative](#)

[SOURce:]CURRent:LIMit:NEGative[:IMMEDIATE][:AMPLitude]**Syntax**

```
[SOURce:]CURRent:LIMit:NEGative[:IMMEDIATE]
[:AMPLitude] <limit>, (@<chanlist>)
```

```
[SOURce:]CURRent:LIMit:NEGative[:IMMEDIATE]
[:AMPLitude]? [MIN|MAX,] (@<chanlist>)
```

Description

This command sets the negative current limit of the specified output channel. Units are in amperes. If [\[SOURce:\]CURRent:LIMit:COUple](#) is enabled, this command also sets the value of the positive current limit. Refer to Appendix E in the N6700 User's Guide under "Voltage Priority" for more information about current limit operation.

NOTE

This command only applies to models N678xA SMU and N6783A-BAT.

Parameters

Name	Type	Range of Values	Default Value
<limit>	NRf+	-3.06 to 0 MIN MAX (N678xA SMU) -2 to 0 MIN MAX (N6783A-BAT)	MIN (of selected range)
<chanlist>	Numeric	One or more channels. (@2) - channel 2 (@1,4) - channels 1 and 4 (@1:3) - channels 1 through 3.	Required parameter

Remarks

MIN refers to the most negative value of the range. MAX refers to the least negative value of the range.

Return Format

```
<NR3>
```

The query command returns the negative current limit in the form +n.nnnnnnE+nn for each channel specified. Multiple responses are separated by commas.

Examples

The following command sets the negative current limit to -3 A on channels 1 and 2.

```
CURR:LIM:NEG -3,(@1,2)
```

The following query returns the negative current limit on channels 1 and 2.

```
CURR:LIM:NEG? (@1,2)
```

Typical Response: -3.000000E+00,-3.000000E+00

See Also

[\[SOURCE:|CURRENT:LIMIT:COUPLE](#)

[\[SOURCE:|CURRENT:LIMIT](#)

[SOURce:]CURRent:MODE**Syntax**

```
[SOURce:]CURRent:MODE <mode>, (@<chanlist>)
```

```
[SOURce:]CURRent:MODE? (@<chanlist>)
```

Description

This command determines what happens to the output current when the transient system is initiated and triggered.

FIXed The output current remains at the immediate value.

STEP The output goes to the triggered level when a trigger occurs.

LIST The output follows the list values when a trigger occurs.

NOTE

List mode is only available with models N6761A/N6762A, or models that have Option 054 (High Speed Test Extensions).

Parameters

Name	Type	Range of Values	Default Value
<mode>	CPD	FIXed STEP LIST	FIXed
<chanlist>	Numeric	One or more channels. (@2) - channel 2 (@1,4) - channels 1 and 4 (@1:3) - channels 1 through 3.	Required parameter

Return Format

```
<CRD>
```

The query command returns the current mode for each channel specified. Multiple responses are separated by commas.

Examples

The following command sets the current mode of channel 4.

```
CURR:MODE STEP, (@4)
```

The following query returns the current mode of channel 1.

```
CURR:MODE? (@1)
```

Typical Response: FIX

See Also

[\[SOURce:\]VOLTage:MODE](#)

[INITiate\[:IMMediate\]:TRANsient](#)

[TRIGger:TRANsient\[:IMMediate\]](#)

[SOURce:]CURRent:PROTection:DELay[:TIME]**Syntax**

```
[SOURce:]CURRent:PROTection:DELay[:TIME] <time>,
(@<chanlist>)

[SOURce:]CURRent:PROTection:DELay[:TIME]? [MIN|MAX, ]
(@<chanlist>)
```

Description

This command sets the over-current protection delay. The over-current protection function will not be triggered on the specified output channel during the delay time. After the delay time has expired, the over-current protection function will be active. This prevents momentary changes in output status from triggering the over-current protection function. Programmed values can range from 0 to 255 milliseconds in increments of 1 millisecond.

The operation of over-current protection is affected by the setting of the current protection delay start event, which is specified by [\[SOURce:\]CURRent:PROTection:DELay:START](#).

Parameters

Name	Type	Range of Values	Default Value
<time>	NRf+	0 - 0.255 MIN MAX	20 ms
<chanlist>	Numeric	One or more channels. (@2) - channel 2 (@1,4) - channels 1 and 4 (@1:3) - channels 1 through 3.	Required parameter

Remarks

This command is the same as [OUTPut:PROTection:DELay](#).

Return Format

```
<NR3>
```

The query command returns the programmed delay time. The reading is in the form +n.nnnnnnE+nn.

Example

The following command sets a current protection delay of 0.5 seconds for channel 2.

```
CURR:PROT:DEL 0.5,(@2)
```

The following query returns the maximum allowable current protection delay of channel 1.

```
CURR:PROT:DEL? MAX,(@1)
```

3 Commands by Subsystem

Typical Response: +2.550000E-01

See Also

[\[SOURCE:|CURRENT:PROTECTION:DELAY](#)

[\[SOURCE:|CURRENT:PROTECTION:DELAY:START](#)

[\[SOURCE:|CURRENT:PROTECTION:STATE](#)

[OUTPUT:PROTECTION:CLEAR](#)

[SOURce:]CURRent:PROTection:DELAy:STARt**Syntax**

```
[SOURce:]CURRent:PROTection:DELAy:STARt <mode>,
(@<chanlist>)
```

```
[SOURce:]CURRent:PROTection:DELAy:STARt?
(@<chanlist>)
```

Description

This command sets the over-current protection delay start event as follows:

SCHange Transitions into constant current mode are automatically ignored during a programmed settings change in voltage, current, or output state. At the end of the settings change, the delay timer is started, allowing for additional protection delay time. There is no protection delay outside of these time windows. This is how the [OUTPut:PROTection:DELAy](#) command functioned prior to the availability of this command.

CCTRans The over-current protection delay timer is started by *any* transition of the output into constant current mode.

Parameters

Name	Type	Range of Values	Default Value
<mode>	CPD	SCHange CCTRans	SCHange
<chanlist>	Numeric	One or more channels. (@2) - channel 2 (@1,4) - channels 1 and 4 (@1:3) - channels 1 through 3.	Required parameter

Return Format

```
<CRD>
```

The query command returns SCH or CCTR.

Example

The following selects CCTRans as the current protection delay mode.

```
CURR:PROT:DEL:STAR CCTR, (@1)
```

The following query returns the current protection delay mode.

```
CURR:PROT:DEL:STAR? (@2)
```

Typical Response: SCH

See Also

[\[SOURCE:|CURRENT:PROTECTION:DELAY](#)

[\[SOURCE:|CURRENT:PROTECTION:STATE](#)

[SOURce:]CURRent:PROTection:STATe**Syntax**

```
[SOURce:]CURRent:PROTection:STATe <Bool>,
(@<chanlist>)

[SOURce:]CURRent:PROTection:STATe? (@<chanlist>)
```

Description

This command enables or disables the over-current protection (OCP) function. The enabled state is On (1); the disabled state is Off (0). If the over-current protection function is enabled and the output goes into constant current operation, the output is disabled and the Questionable Condition status register OCP bit is set.

Parameters

Name	Type	Range of Values	Default Value
<Bool>	Boolean	OFF 0 ON 1	OFF
<chanlist>	Numeric	One or more channels. (@2) - channel 2 (@1,4) - channels 1 and 4 (@1:3) - channels 1 through 3.	Required parameter

Remarks

The current limit setting determines when the output channel goes into constant current operation.

An over-current condition can be cleared with [OUTPut:PROTection:CLEar](#) after the cause of the condition is removed.

Return Format

<NR1>

The query command returns 0 if the current protection state is OFF, and 1 if the current protection state is ON.

Examples

The following command sets the current protection state of channel 4.

```
CURR:PROT:STAT ON, (@4)
```

The following query returns the current protection state of channel 1.

```
CURR:PROT:STAT? (@1)
```

Typical Response: 0

See Also

[OUTPut:PROTection:CLEar](#)

[SOURce:]CURRent:RANGe**Syntax**

```
[SOURce:]CURRent:RANGe <range>, (@<chanlist>)
```

```
[SOURce:]CURRent:RANGe? [MIN|MAX,] (@<chanlist>)
```

Description

This command sets the output current range on models that have multiple ranges. The value that you enter must be the highest value in amperes that you expect to source. The instrument selects the range with the best resolution for the value entered.

Parameters

Name	Type	Range of Values	Default Value
<range>	NRf+	0 - maximum MIN MAX Values entered are model dependent.	MAX
<chanlist>	Numeric	One or more channels. (@2) - channel 2 (@1,4) - channels 1 and 4 (@1:3) - channels 1 through 3.	Required parameter

Remarks

This command is coupled with the [SOURce:]CURRent command. This means that if a range command is sent that places an output on a range with a lower maximum current than the present current level, an error is generated. This also occurs if a current level is programmed with a value too large for the present range.

These types of errors can be avoided by sending the both level and range commands in the same SCPI message. When the range and setting information is received as a set, no range/setting conflict occurs.

If programming a range value causes a range change to occur while the output is enabled, the output will be temporarily disabled while the range switch occurs. The transition from on-to-off and then from off-to-on will also be delayed by the settings of OUTPut:DELAy:FALL and OUTPut:DELAy:RISE.

Return Format

```
<NR3>
```

The query command returns the maximum current that can be output on the range that is presently set. The current level is in the form +n.nnnnnnE+nn for each channel specified. Multiple responses are separated by commas.

Examples

The following command sets the output current range to 1 A on channels 1 and 2.

```
CURR:RANG 1,(@1,2)
```

The following query returns the programmed current range on channels 1 and 2.

```
CURR:RANG? (@1,2)
```

Typical Response: +1.000000E+00,+1.000000E+00

See Also

[\[SOURCE:|CURRENT\[:LEVEL\]\]\[:IMMEDIATE\]](#)

[SOURce:]CURRent:SLEW[:IMMediate]**Syntax**

```
[SOURce:]CURRent:SLEW[:IMMediate] <slew>|INFinity,
(@<chanlist>)
```

```
[SOURce:]CURRent:SLEW[:IMMediate]? [MIN|MAX, ]
(@<chanlist>)
```

Description

This command sets the current slew rate in amps per second. The slew rate setting affects all programmed current changes, including those due to the output state turning on or off. The slew rate can be set to any value between 0 and 9.9E+37. For very large values, the slew rate will be limited by the analog performance of the output circuit. The keywords MAX or INFinity set the slew rate to maximum.

The query returns the value that was sent, unless the value was less than the minimum slew rate, in which case the minimum value is returned. The LSB weight of the 24-bit register can be queried using CURRent:SLEW? MIN. The exact value varies slightly according to the current calibration.

NOTE

This command only applies to models N678xA SMU.

Parameters

Name	Type	Range of Values	Default Value
<slew>	NRf+	0 - 9.9E+37 MIN MAX INFinity	9.9E+37
<chanlist>	Numeric	One or more channels. (@2) - channel 2 (@1,4) - channels 1 and 4 (@1:3) - channels 1 through 3.	Required parameter

Return Format

```
<NR3>
```

The query command returns the programmed slew rate in the form +n.nnnnnnE+nn for each channel specified. Multiple responses are separated by commas. If a slew rate of 9.9E37 is returned, it means that the maximum or fastest slew rate has been set.

Examples

The following command sets the slew rate to 1 amp per second on channel 1.

```
CURR:SLEW 1,(@1)
```

The following query returns the programmed slew rate on channel 1.

```
CURR:SLEW? (@1)
```

Typical Response: +1.000000E+00

See Also

[\[SOURCE:VOLTage:SLEW\]](#)

[\[SOURCE:CURRENT:SLEW:MAX\]](#)

[SOURce:]CURRent:SLEW:MAXimum**Syntax**

```
[SOURce:]CURRent:SLEW:MAXimum <Bool>, (@<chanlist>)
[SOURce:]CURRent:SLEW:MAXimum? (@<chanlist>)
```

Description

This command sets the current slew rate maximum override. When enabled (ON), the power module's slew rate is set to its maximum value. When disabled (OFF), the power module's slew rate is set to the immediate value set by the [SOURce:]CURRent:SLEW command. [SOURce:]CURRent:SLEW:MAX does not affect the [SOURce:]CURRent:SLEW setting.

Use [SOURce:]CURRent:SLEW? MAX to query the maximum slew rate that was set.

NOTE

This command only applies to models N678xA SMU.

Parameters

Name	Type	Range of Values	Default Value
<Bool>	Boolean	OFF 0 ON 1	OFF
<chanlist>	Numeric	One or more channels. (@2) - channel 2 (@1,4) - channels 1 and 4 (@1:3) - channels 1 through 3.	Required parameter

Remarks

The [SOURce:]CURRent:SLEW:MAX command is coupled to the [SOURce:]CURRent:SLEW command. If [SOURce:]CURRent:SLEW sets the rate to MAX or INFINITY, [SOURce:]CURRent:SLEW:MAX is enabled. If the slew rate is set to any other value, [SOURce:]CURRent:SLEW:MAX is disabled.

Return Format

```
<NR1>
```

The query command returns 0 if the slew rate override is disabled, and 1 if the slew rate override is enabled.

Examples

The following command enables the slew rate maximum override on channel 1.

```
CURR:SLEW:MAX ON, (@1)
```

3 Commands by Subsystem

The following query returns the state of the slew rate override on channel 1.

```
CURR:SLEW:MAX? (@1)
```

Typical Response: 1

See Also

[\[SOURCE:|CURRENT:SLEW](#)

[\[SOURCE:|VOLTAGE:SLEW:MAXIMUM](#)

[SOURce:]DIGital:INPut:DATA?

Syntax

```
[SOURce:]DIGital:INPut:DATA?
```

Description

This query reads the state of the digital control port.

Return Format

```
<NR1>
```

The query returns the binary-weighted value of the state of pins 1 through 7 in bits 0 through 6 respectively.

Example

The following query returns the state of the digital control port pins.

```
DIG:INP:DATA?
```

Typical Response: +0

See Also

[\[SOURce:\]DIGital:OUTput:DATA](#)

[SOURce:]DIGital:OUTPut:DATA**Syntax**

```
[SOURce:]DIGital:OUTPut:DATA <value>
```

```
[SOURce:]DIGital:OUTPut:DATA?
```

Description

This command sets the output data on the digital control port when that port is configured for Digital I/O operation. The port has seven signal pins and a digital ground pin. In the binary-weighted value that is written to the port, the pins are controlled according to the following bit assignments:

Pin	Bit Number	Decimal Value
1	0	1
2	1	2
3	2	4
4	3	8
5	4	16
6	5	32
7	6	64

Parameters

Name	Type	Range of Values	Default Value
<value>	NRf	0 - 127	0

Return Format

```
<NR1>
```

The query returns the last programmed value of the bits. To read the actual state of the pin, use [\[SOURce:\]DIGital:INPut:DATA?](#)

Example

The following command programs pins 1, 3, and 5 on. (bit 0 = 1; bit 2 = 4; bit 4 = 16) (1 + 4 + 16 = 21)

```
DIG:OUTP:DATA 21
```

The following query returns the state of the digital control port pins.

```
DIG:OUTP:DATA?
```

Typical Response: +21

See Also

[\[SOURce:\]DIGital:INPut:DATA?](#)

[SOURce:]DIGital:PIN<1-7>:FUNction

Syntax

```
[SOURce:]DIGital:PIN<1-7>:FUNction <function>
[SOURce:]DIGital:PIN<1-7>:FUNction?
```

Description

This command sets the functions of the digital port pins. The pin functions are saved in non-volatile memory.

DIO	The pin is a general-purpose ground-referenced digital input/output. The output can be set with [SOURce:]DIGital:OUTPut:DATA .
DINPut	The pin is in digital input-only mode. The digital output data of the corresponding pin is ignored.
TOUTput	The pin is configured as a trigger output. When configured as a trigger output, the pin will only generate output triggers if the Step or List transient system has been configured to generated trigger signals. See: [SOURce:]STEP:TOUTput , [SOURce:]LIST:TOUTput:BOSTep , and [SOURce:]LIST:TOUTput:EOSTep
TINPut	The pin is configured as a trigger input. When configured as a trigger input, the pin can be selected as the source for measurement and transient trigger signals. See TRIGger:ACQuire:SOURce and TRIGger:TRANsient:SOURce
FAULT	<i>Applies only to pin 1.</i> Setting FAULt means that pin 1 functions as an isolated fault output. The fault signal is true when any output is in a protected state (from OC, OV, OT, INH, PF, or CP+ on some models). Note also that Pin 2 serves as the isolated common for pin 1. When pin 1 is set to the FAULt function, the instrument ignores any commands to program pin 2. Queries of pin 2 will return FAULt. If pin 1 is changed from FAULt to another function, pin 2 is set to DINPut.
INHibit	<i>Applies only to pin 3.</i> When pin 3 is configured as an inhibit input, a true signal at the pin will disable all output channels.
ONCouple	<i>Applies only to pins 4 -7.</i> When configured as an On control, the pin will synchronize the output On state between mainframes. Only one pin can be configured as an On control. The pin will function as both an input and an output. The polarity of the pin is fixed and cannot be programmed.
OFFCouple	<i>Applies only to pins 4-7.</i> When configured as an Off control, the pin will synchronize the output Off state between mainframes. Only one pin can be configured as an Off control. The pin will function as both an input and an output. The polarity of the pin is fixed and cannot be programmed.

Parameters

Name	Type	Range of Values	Default Value
<function>	CPD	DIO DINPut TOUTput TINPut FAULt INHibit ONCouple OFFCouple	Required parameter

Return Format

<CRD>

The query command returns DIO, DINP, TOUT, TINP, FAUL, INH, ONC, or OFFC.

Example

The following command sets pin 1 to Fault mode.

```
DIG:PIN1:FUNC FAUL
```

The following query returns the setting of pin 7.

```
DIG:PIN7:FUNC?
```

Typical Response: DIO

See Also

[\[SOURCE:\]DIGital:PIN<1-7>:POLarity](#)

[SOURce:]DIGital:PIN<1-7>:POLarity**Syntax**

```
[SOURce:]DIGital:PIN<1-7>:POLarity <polarity>
```

```
[SOURce:]DIGital:PIN<1-7>:POLarity?
```

Description

This command sets the polarity of the digital port pins. The pin polarities are saved in non-volatile memory.

POSitive Setting a polarity to POSitive means that a logical true signal is a voltage high at the pin. For trigger inputs and outputs, POSitive means a rising edge.

NEGative Setting the polarity NEGative means that a logical true signal is a voltage low at the pin. For trigger inputs and outputs, NEGative means a falling edge.

Parameters

Name	Type	Range of Values	Default Value
<function>	CPD	POSitive NEGative	Required parameter

Return Format

```
<CRD>
```

The query command returns POS or NEG.

Example

The following command sets pin 1 to negative polarity.

```
DIG:PIN1:POL NEGative
```

The following query returns the polarity of pin 7.

```
DIG:PIN7:POL?
```

Typical Response: POS

See Also

[\[SOURce:\]DIGital:PIN<1-7>:FUNCTION](#)

[SOURce:]DIGital:TOUTput:BUS[:ENABLE]**Syntax**

```
[SOURce:]DIGital:TOUTput:BUS[:ENABLE] <Bool>
```

```
[SOURce:]DIGital:TOUTput:BUS[:ENABLE]?
```

Description

This command allows a BUS trigger to be sent to any digital port pin that has been configured as a trigger output. The state is either ON (1) or OFF (0). A trigger is generated when the state is True (ON). A BUS trigger is generated using the *TRG command.

Parameters

Name	Type	Range of Values	Default Value
<Bool>	Boolean	OFF 0 ON 1	OFF

Remarks

Pins 1 – 7 must be configured as trigger outputs before they can generate a trigger signal. See [\[SOURce:\]DIGital:PIN<1-7>:FUNCTION](#) and [\[SOURce:\]DIGital:PIN<1-7>:POLarity](#).

Return Format

```
<NR1>
```

The query command returns 0 (OFF) if the trigger signal will NOT be generated when a BUS trigger command occurs, and 1(ON) if a trigger signal will be generated when a BUS trigger command occurs.

Examples

The following command enables BUS-generated trigger signals on the digital pins.

```
DIG:TOUT:BUS ON
```

The following query returns the state BUS-generated trigger signals on the digital pins.

```
DIG:TOUT:BUS?
```

Typical Response: 0

See Also

[\[SOURce:\]DIGital:PIN<1-7>:FUNCTION](#)

[\[SOURce:\]DIGital:PIN<1-7>:POLarity](#)

[SOURce:]FUNCTION**Syntax**

```
[SOURce:]FUNCTION <mode>, (@<chanlist>)
```

```
[SOURce:]FUNCTION? (@<chanlist>)
```

Description

This command selects whether the output regulation on models N678xA is in voltage priority or current priority mode. In voltage priority mode the output is controlled by a bi-polar constant voltage feedback loop, which maintains the output voltage at its positive or negative programmed setting. In current priority mode the output is controlled by a bi-polar constant current feedback loop, which maintains the output sourcing or sinking current at its programmed setting. Refer to Appendix E in the N6700 User's Guide for more information about priority mode operation.

NOTE

This command only applies to models N678xA SMU.

Parameters

Name	Type	Range of Values	Default Value
<mode>	CPD	CURRent VOLTage	VOLTage
<chanlist>	Numeric	One or more channels. (@2) - channel 2 (@1,4) - channels 1 and 4 (@1:3) - channels 1 through 3.	Required parameter

Return Format

```
<CRD>
```

The query command returns the priority mode setting for each channel specified. Multiple responses are separated by commas.

Examples

The following command selects voltage priority mode on channel 3.

```
FUNC VOLT, (@3)
```

The following query returns the mode selected on channel 1.

```
FUNC? (@1)
```

Typical Response: "VOLT"

[SOURce:]LIST:COUNT**Syntax**

```
[SOURce:]LIST:COUNT <count>|INFinity, (@<chanlist>)
```

```
[SOURce:]LIST:COUNT? [MIN|MAX|INFinity, ]  
(@<chanlist>)
```

Description

This command sets the number of times that the list is executed before it is completed. The list count range is 1 through 256.

NOTE

List mode is only available with models N676xA, N678xA SMU, or models that have Option 054 (High Speed Test Extensions).

Parameters

Name	Type	Range of Values	Default Value
<count>	NRf+	1 - 256 MIN MAX INFinity	1
<chanlist>	Numeric	One or more channels. (@2) - channel 2 (@1,4) - channels 1 and 4 (@1:3) - channels 1 through 3.	Required parameter

Remarks

Use the INFinity parameter to execute a list continuously.

Use [ABORt:TRANsient](#) to stop the list at any time. When the list is aborted, the output returns to the settings that were in effect before the list started.

Return Format

```
<NR1>
```

The query command returns the list count for each channel specified. Multiple responses are separated by commas. If a repeat count of 9.9E37 is returned, it means the list is set to repeat continuously.

Examples

The following command sets the list count to 10 on channel 1.

```
LIST:COUN 10, (@1)
```

The following query returns the list count of channel 1.

```
LIST:COUN? (@1)
```

Typical Response: +10

[SOURCE:]LIST:CURRENT[:LEVEL]**Syntax**

```
[SOURCE:]LIST:CURRENT[:LEVEL] <current>{,<current>},
(@<chanlist>)
```

```
[SOURCE:]LIST:CURRENT[:LEVEL]? (@<chanlist>)
```

Description

This command specifies the current setting for each list step in amperes. A comma-delimited list of up to 512 steps may be programmed.

NOTE

List mode is only available with models N676xA, N678xA SMU, or models that have Option 054 (High Speed Test Extensions).

Parameters

Name	Type	Range of Values	Default Value
<current>	NRf	0 – maximum The maximum value is dependent on the current rating of the power module.	1 step set to the minimum programmable value
<chanlist>	Numeric	One or more channels. (@2) - channel 2 (@1,4) - channels 1 and 4 (@1:3) - channels 1 through 3.	Required parameter

Remarks

The order in which the current values are entered determines the sequence when the list executes.

To create a valid list, the Voltage, Current, BOST, EOST, and Dwell lists must either all be the same length, or have a length of 1, which is interpreted as having the same length as the list with the maximum length.

This command overwrites any previously programmed current list; it does not append to the previous list.

Return Format

```
<NR3>
```

The query command returns the programmed current level in the form +n.nnnnnnE+nn. Multiple responses are separated by commas.

Examples

The following command programs a current list. The list contains 5 steps and is on channel 1.

```
LIST:CURR 5,4,3,2,1,(@1)
```

The following query returns the current list settings of channel 1.

```
LIST:CURR? (@1)
```

Typical Response:

```
+5.000000E+00,+4.000000E+00,+3.000000E+00,+2.000000  
E+00,+1.000000E+00
```

See Also

[\[SOURCE:LIST:DWEL\]](#)

[\[SOURCE:LIST:VOLTage\[:LEVel\]](#)

[SOURce:]LIST:CURRent:POINts?**Syntax**

```
[SOURce:]LIST:CURRent:POINts? (@<chanlist>)
```

Description

This query returns the number of points (steps) in the current list, not the point values.

NOTE

List mode is only available with models N676xA, N678xA SMU, or models that have Option 054 (High Speed Test Extensions).

Parameters

Name	Type	Range of Values	Default Value
<chanlist>	Numeric	One or more channels. (@2) - channel 2 (@1,4) - channels 1 and 4 (@1:3) - channels 1 through 3.	Required parameter

Return Format

```
<NR1>
```

The number of points in the current list. Multiple responses are separated by commas.

Example

The following query returns the number of points in a current list for channel 1.

```
LIST:CURR:POIN? (@1)
```

Typical Response: +1

[SOURce:]LIST:DWELL**Syntax**

```
[SOURce:]LIST:DWELL <time>{,<time>}, (@<chanlist>)
[SOURce:]LIST:DWELL? (@<chanlist>)
```

Description

This command specifies the dwell time for each list step. A comma-delimited list of up to 512 steps may be programmed. Dwell time is the time that the output will remain at a specific step. Dwell times can be programmed from 0 through 262.144 seconds with the following resolution:

Range in seconds	Resolution
0 - 0.262144	1 microsecond
0.262144 - 2.62144	10 microseconds
2.62144 - 26.2144	100 microseconds
26.2144 - 262.144	1 millisecond

NOTE

List mode is only available with models N676xA, N678xA SMU, or models that have Option 054 (High Speed Test Extensions).

Parameters

Name	Type	Range of Values	Default Value
<time>	NRf	0 - 262.144	1 step with a value of 0.001
<chanlist>	Numeric	One or more channels. (@2) - channel 2 (@1,4) - channels 1 and 4 (@1:3) - channels 1 through 3.	Required parameter

Remarks

At the end of the dwell time, the output state of the unit depends upon the [\[SOURce:\]LIST:STEP](#) program settings.

The order in which the dwell values are entered determines the sequence when the list executes.

To create a valid list, the Voltage, Current, BOST, EOST, and Dwell lists must either all be the same length, or have a length of 1, which is interpreted as having the same length as the list with the maximum length.

This command overwrites any previously programmed dwell list; it does not append to the previous list.

Return Format

<NR3>

The query command returns the programmed dwell time in the form +n.nnnnnE+nn. Multiple responses are separated by commas.

Examples

The following command programs a dwell list. The list contains 5 steps and is on channel 1.

```
LIST:DWEL 0.2,0.8,1.5,0.8,0.2,(@1)
```

The following query returns the dwell list settings of channel 1.

```
LIST:DWEL? (@1)
```

Typical Response:

```
+2.000000E-01,+8.000000E-01,+1.500000E+00,+8.000000E-01,+02.000000E-01
```

See Also

[\[SOURCE:\]LIST:CURRENT\[:LEVEL\]](#)

[\[SOURCE:\]LIST:VOLTAGE\[:LEVEL\]](#)

[SOURce:]LIST:DWEL:POINts?**Syntax**

```
[SOURce:]LIST:DWEL:POINts? (@<chanlist>)
```

Description

This query returns the number of points (steps) in the dwell list, not the point values.

NOTE

List mode is only available with models N676xA, N678xA SMU, or models that have Option 054 (High Speed Test Extensions).

Parameters

Name	Type	Range of Values	Default Value
<chanlist>	Numeric	One or more channels. (@2) - channel 2 (@1,4) - channels 1 and 4 (@1:3) - channels 1 through 3.	Required parameter

Return Format

```
<NR1>
```

The number of points in the dwell list. Multiple responses are separated by commas.

Example

The following query returns the number of points in a dwell list for channel 1.

```
LIST:DWEL:POIN? (@1)
```

Typical Response: +1

[SOURCE:]LIST:STEP**Syntax**

```
[SOURCE:]LIST:STEP <response>, (@<chanlist>)
```

```
[SOURCE:]LIST:STEP? (@<chanlist>)
```

Description

This command specifies how the list responds to triggers.

ONCE Causes the output to remain at the present step until a trigger advances it to the next step. Triggers that arrive during the dwell time are ignored.

AUTO Causes the output to automatically advance to each step, after the receipt of an initial starting trigger. The steps are paced by the dwell list. As each dwell time elapses, the next step is immediately output.

NOTE

List mode is only available with models N676xA, N678xA SMU, or models that have Option 054 (High Speed Test Extensions).

Parameters

Name	Type	Range of Values	Default Value
<response>	CPD	ONCE AUTO	AUTO
<chanlist>	Numeric	One or more channels. (@2) - channel 2 (@1,4) - channels 1 and 4 (@1:3) - channels 1 through 3.	Required parameter

Return Format

```
<CRD>
```

The query command returns the list step setting. Multiple responses are separated by commas.

Examples

The following command sets the list step setting of channel 1 to ONCE, causing the list steps to be paced by trigger signals.

```
LIST:STEP ONCE, (@1)
```

The following query returns the list step setting of channel 1.

```
VOLT:MODE? (@4)
```

Typical Response: ONCE

See Also

[\[SOURCE:LIST:TERMinate:LAST](#)

[SOURce:]LIST:TERMinate:LAST**Syntax**

```
[SOURce:]LIST:TERMinate:LAST <Bool>, (@<chanlist>)
```

```
[SOURce:]LIST:TERMinate:LAST? (@<chanlist>)
```

Description

This command determines the output value when the list terminates. The state is either ON (1) or OFF (0).

When ON, the output voltage or current remains at the value of the last list step. The value of the last voltage or current list step becomes the IMMEDIATE value when the list completes.

When OFF, and also when the list is aborted, the output returns to the settings that were in effect before the list started.

NOTE

List mode is only available with models N676xA, N678xA SMU, or models that have Option 054 (High Speed Test Extensions).

Parameters

Name	Type	Range of Values	Default Value
<Bool>	Boolean	OFF 0 ON 1	OFF
<chanlist>	Numeric	One or more channels. (@2) - channel 2 (@1,4) - channels 1 and 4 (@1:3) - channels 1 through 3.	Required parameter

Return Format

```
<NR1>
```

The query command returns 0 if the output returns to the settings that were in effect before the list started, and 1 if the output voltage or current remains at the value of the last list step.

Examples

The following command sets the list to terminate with the output voltage or current remaining at the value of the last list step on channel 2.

```
LIST:TERM:LAST ON, (@2)
```

The following query returns the list terminate setting of channel 1.

```
LIST:TERM:LAST? (@1)
```

Typical Response: 0

See Also

[\[SOURCE:LIST:STEP](#)

[SOURce:]LIST:TOUTput:BOST:POINts?**Syntax**

[SOURce:]LIST:TOUTput:BOST:POINts? (@<chanlist>)

Description

This query returns the number of points (steps) in the beginning of the step trigger list (BOSTep), not the point values.

NOTE

List mode is only available with models N676xA, N678xA SMU, or models that have Option 054 (High Speed Test Extensions).

Parameters

Name	Type	Range of Values	Default Value
<chanlist>	Numeric	One or more channels. (@2) - channel 2 (@1,4) - channels 1 and 4 (@1:3) - channels 1 through 3.	Required parameter

Return Format

<NR1>

The number of points in the BOSTep list. Multiple responses are separated by commas.

Example

The following query returns the number of points in a BOSTep list for channel 1.

```
LIST:TOUT:BOST:POIN? (@1)
```

Typical Response: +1

[SOURCE:]LIST:TOUTput:BOSTep[:DATA]**Syntax**

```
[SOURCE:]LIST:TOUTput:BOSTep[:DATA] <Bool>{ , <Bool> } ,
(@<chanlist>)
```

```
[SOURCE:]LIST:TOUTput:BOSTep[:DATA]? (@<chanlist>)
```

Description

This command specifies which list steps generate a trigger signal at the beginning of the step (BOSTep). A comma-delimited list of up to 512 steps may be programmed. The state is either ON (1) or OFF (0).

A trigger is only generated when the state is set to ON. The trigger signal can be used as a trigger source for measurements and transients of other channels, and for digital port pins configured as trigger outputs.

NOTE

List mode is only available with models N676xA, N678xA SMU, or models that have Option 054 (High Speed Test Extensions).

Parameters

Name	Type	Range of Values	Default Value
<Bool>	Boolean	OFF 0 ON 1	1 step with a value of OFF
<chanlist>	Numeric	One or more channels. (@2) - channel 2 (@1,4) - channels 1 and 4 (@1:3) - channels 1 through 3.	Required parameter

Remarks

The order in which the BOSTep values are entered determines the sequence when the list executes.

To create a valid list, the Voltage, Current, BOST, EOST, and Dwell lists must either all be the same length, or have a length of 1, which is interpreted as having the same length as the list with the maximum length.

This command overwrites any previously programmed BOSTep list; it does not append to the previous list.

Return Format

```
<NR1>
```

The query command returns 0 if no trigger is generated, and 1 if a trigger is generated. Multiple responses are separated by commas.

Examples

The following command specifies that triggers will be generated at the beginning of each list step. The list contains 5 steps and is on channel 1.

```
LIST:TOUT:BOST ON,ON,ON,ON,ON,(@1)
```

The following query returns the list step trigger settings of channel 1.

```
LIST:TOUT:BOST? (@1)
```

Typical Response: 1,1,1,1,1

See Also

[\[SOURCE:LIST:TOUTput:EOSTep\[:DATA\]\]](#)

[SOURCE:]LIST:TOUTput:EOST:POINts?**Syntax**

```
[SOURCE:]LIST:TOUTput:EOST:POINts? (@<chanlist>)
```

Description

This query returns the number of points (steps) in the end of the step trigger list (EOSTep), not the point values.

NOTE

List mode is only available with models N676xA, N678xA SMU, or models that have Option 054 (High Speed Test Extensions).

Parameters

Name	Type	Range of Values	Default Value
<chanlist>	Numeric	One or more channels. (@2) - channel 2 (@1,4) - channels 1 and 4 (@1:3) - channels 1 through 3.	Required parameter

Return Format

```
<NR1>
```

The number of points in the EOSTep list. Multiple responses are separated by commas.

Example

The following query returns the number of points in a EOSTep list for channel 1.

```
LIST:TOUT:EOST:POIN? (@1)
```

Typical Response: +1

[SOURCE:]LIST:TOUTput:EOSTep[:DATA]

Syntax

[SOURCE:]LIST:TOUTput:EOSTep[:DATA] <Bool>{,<Bool>},
(@<chanlist>)

[SOURCE:]LIST:TOUTput:EOSTep[:DATA]? (@<chanlist>)

Description

This command specifies which list steps generate a trigger signal at the end of the step (EOSTep). A comma-delimited list of up to 512 steps may be programmed. The state is either ON (1) or OFF (0).

A trigger is only generated when the state is set to ON. The trigger signal can be used as a trigger source for measurements and transients of other channels, and for digital port pins configured as trigger outputs.

NOTE

List mode is only available with models N676xA, N678xA SMU, or models that have Option 054 (High Speed Test Extensions).

Parameters

Name	Type	Range of Values	Default Value
<Bool>	Boolean	OFF 0 ON 1	1 step with a value of OFF
<chanlist>	Numeric	One or more channels. (@2) - channel 2 (@1,4) - channels 1 and 4 (@1:3) - channels 1 through 3.	Required parameter

Remarks

The order in which the EOStep values are entered determines the sequence when the list executes.

To create a valid list, the Voltage, Current, BOST, EOStep, and Dwell lists must either all be the same length, or have a length of 1, which is interpreted as having the same length as the list with the maximum length.

This command overwrites any previously programmed EOStep list; it does not append to the previous list.

Return Format

<NR1>

The query command returns 0 if no trigger is generated, and 1 if a trigger is generated. Multiple responses are separated by commas.

Examples

The following command specifies that triggers will be generated at the end of each list step. The list contains 5 steps and is on channel 1.

```
LIST:TOUT:EOST ON,ON,ON,ON,ON,(@1)
```

The following query returns the list step trigger settings of channel 1.

```
LIST:TOUT:EOST? (@1)
```

Typical Response: 1,1,1,1,1

See Also

[\[SOURCE:LIST:TOUTput:BOSTep\[:DATA\]\]](#)

[SOURce:]LIST:VOLTage[:LEVel]

Syntax

[SOURce:]LIST:VOLTage[:LEVel] <voltage>{,<voltage>},
(@<chanlist>)

[SOURce:]LIST:VOLTage[:LEVel]? (@<chanlist>)

Description

This command specifies the voltage setting for each list step in volts. A comma-delimited list of up to 512 steps may be programmed.

NOTE

List mode is only available with models N676xA, N678xA SMU, or models that have Option 054 (High Speed Test Extensions).

Parameters

Name	Type	Range of Values	Default Value
<voltage>	NRf	0 – maximum The maximum value is dependent on the voltage rating of the power module.	1 step set to the minimum programmable value
<chanlist>	Numeric	One or more channels. (@2) - channel 2 (@1,4) - channels 1 and 4 (@1:3) - channels 1 through 3.	Required parameter

Remarks

The order in which the voltage values are entered determines the sequence when the list executes.

To create a valid list, the Voltage, Current, BOST, EOSt, and Dwell lists must either all be the same length, or have a length of 1, which is interpreted as having the same length as the list with the maximum length.

This command overwrites any previously programmed voltage list; it does not append to the previous list.

Return Format

<NR3>

The query command returns the programmed voltage level in the form +n.nnnnnnE+nn. Multiple responses are separated by commas.

Examples

The following command programs a voltage list. The list contains 5 steps and is on channel 1.

3 Commands by Subsystem

```
LIST:VOLT 10,20,30,40,50,(@1)
```

The following query returns the voltage list settings of channel 1.

```
LIST:VOLT? (@1)
```

Typical Response:

```
+1.000000E+01,+2.000000E+01,+3.000000E+01,+4.000000  
E+01,+5.000000E+01
```

See Also

[\[SOURCE:LIST:DWEL\]](#)

[\[SOURCE:LIST:CURRENT\[:LEVEL\]\]](#)

[SOURce:]LIST:VOLTage:POINts?**Syntax**

```
[SOURce:]LIST:VOLTage:POINts? (@<chanlist>)
```

Description

This query returns the number of points (steps) in the voltage list, not the point values.

NOTE

List mode is only available with models N676xA, N678xA SMU, or models that have Option 054 (High Speed Test Extensions).

Parameters

Name	Type	Range of Values	Default Value
<chanlist>	Numeric	One or more channels. (@2) - channel 2 (@1,4) - channels 1 and 4 (@1:3) - channels 1 through 3.	Required parameter

Return Format

```
<NR1>
```

The number of points in the voltage list. Multiple responses are separated by commas.

Example

The following query returns the number of points in a voltage list for channel 1.

```
LIST:VOLT:POIN? (@1)
```

Typical Response: +1

[SOURce:]POWer:LIMit**Syntax**

```
[SOURce:]POWer:LIMit <power>, (@<chanlist>)
[SOURce:]POWer:LIMit? [MIN|MAX,] (@<chanlist>)
```

Description

This command sets the power limit on output channels. Units are in Watts.

For the majority of Agilent N6700 configurations, full power is available from all installed power modules. However, it is possible to configure a mainframe in which the combined ratings of the power modules exceed the power rating of the mainframe.

For these instrument configurations, the power allocation lets you programmatically limit the output power of some of the power modules so that the combined output power does not exceed the power rating of the mainframe. Refer to Appendix C in the User's Guide for more information.

Parameters

Name	Type	Range of Values	Default Value
<power>	NRf+	0 - maximum MIN MAX	MAX
<chanlist>	Numeric	One or more channels. (@2) - channel 2 (@1,4) - channels 1 and 4 (@1:3) - channels 1 through 3.	Required parameter

Remarks

Setting a power limit of MAX on an output channel sets the output channel to its maximum rated power limit. If the power limit is left at the maximum rating, then the power module will not enable its power limit function.

Querying MAX on an output channel returns the maximum rated power limit.

Return Format

```
<NR3>
```

The query command returns the programmed power level in the form +n.nnnnnnE+nn for each channel specified. Multiple responses are separated by commas.

Examples

The following command sets the power limit to 75 W on channels 1 and 2.

```
POW:LIM 75, (@1, 2)
```

The following query returns the programmed power limit on channels 1 and 2.

```
POW:LIM? (@1, 2)
```

Typical Response: +7.500000E+01, +7.500000E+01

[SOURce:]RESistance[:LEVel][:IMMediate][:AMPLitude]**Syntax**

```
[SOURce:]RESistance[:LEVel][:IMMediate][:AMPLitude]
<resistance>, (@<chanlist>)
```

```
[SOURce:]RESistance[:LEVel][:IMMediate][:AMPLitude]?
[MIN|MAX,] (@<chanlist>)
```

Description

This command sets the resistance level of the specified output channel. Units are in ohms. Resistance programming is enabled with [\[SOURce:\]RESistance:STATe](#).

NOTE

This command only applies to model N6781A.

Parameters

Name	Type	Range of Values	Default Value
<resistance>	NRf+	-40 mΩ to + 1 Ω MIN MAX	0
<chanlist>	Numeric	One or more channels. (@2) - channel 2 (@1,4) - channels 1 and 4 (@1:3) - channels 1 through 3.	Required parameter

Return Format

```
<NR3>
```

The query command returns the programmed resistance in the form +n.nnnnnnE+nn for each channel specified. Multiple responses are separated by commas.

Examples

The following command sets the output resistance to 0.5 A on channel 1.

```
RES 0.5, (@1)
```

The following query returns the programmed resistance level on channels 1 and 2.

```
RES? (@1)
```

Typical Response: +5.000000E-01

See Also

[\[SOURce:\]RESistance:STATe](#)

[SOURCE:]RESistance:STATe**Syntax**

```
[SOURCE:]RESistance:STATE <Bool>, (@<chanlist>)
```

```
[SOURCE:]RESistance:STATE? (@<chanlist>)
```

Description

This command enables or disables output resistance programming. The enabled state is ON (1); the disabled state is OFF (0). The output resistance level is set with [\[SOURCE:\]RESistance](#).

NOTE

This command only applies to model N6781A.

Parameters

Name	Type	Range of Values	Default Value
<Bool>	Boolean	OFF 0 ON 1	OFF
<chanlist>	Numeric	One or more channels. (@2) - channel 2 (@1,4) - channels 1 and 4 (@1:3) - channels 1 through 3.	Required parameter

Return Format

```
<NR1>
```

The query command returns 0 if resistance programming is disabled, and 1 if the resistance programming is enabled.

Examples

The following command enables resistance programming for channel 2.

```
RES:STAT ON, (@2)
```

The following query returns the resistance programming state of channel 1.

```
RES:STAT? (@1)
```

Typical Response: 0

See Also

[\[SOURCE:\]RESistance](#)

[SOURce:]STEP:TOUTput**Syntax**

```
[SOURce:]STEP:TOUTput <Bool>, (@<chanlist>)
```

```
[SOURce:]STEP:TOUTput? (@<chanlist>)
```

Description

This command specifies whether an output trigger signal is generated when a transient voltage or current step occurs. The state is either ON (1) or OFF (0). A trigger is generated when the state is True (ON).

Parameters

Name	Type	Range of Values	Default Value
<Bool>	Boolean	OFF 0 ON 1	OFF
<chanlist>	Numeric	One or more channels. (@2) - channel 2 (@1,4) - channels 1 and 4 (@1:3) - channels 1 through 3.	Required parameter

Return Format

```
<NR1>
```

The query command returns 0 if the trigger signal will NOT be generated (OFF) when a step occurs, and 1 if a trigger signal will be generated (ON) when a step occurs.

Examples

The following command sets the step trigger signal ON for channel 2.

```
STEP:TOUT ON, (@2)
```

The following query returns the step trigger signal state of channel 1.

```
STEP:TOUT? (@1)
```

Typical Response: 0

See Also

[TRIGger:ACQuire:SOURce](#)

[TRIGger:TRANsient:SOURce](#)

[SOURce:]VOLTage[:LEVel][:IMMediate][:AMPLitude]

Syntax

```
[SOURce:]VOLTage[:LEVel][:IMMediate][:AMPLitude]
<voltage>, (@<chanlist>)
```

```
[SOURce:]VOLTage[:LEVel][:IMMediate][:AMPLitude]?
[MIN|MAX,] (@<chanlist>)
```

Description

This command sets the immediate voltage level of the specified output channel. Units are in volts. The immediate level is the output voltage setting.

Parameters

Name	Type	Range of Values	Default Value
<voltage>	NRf+	0 - maximum MIN MAX The maximum value is dependent on the voltage rating of the power module.	MIN
<chanlist>	Numeric	One or more channels. (@2) - channel 2 (@1,4) - channels 1 and 4 (@1:3) - channels 1 through 3.	Required parameter

Remarks

This command is coupled with [\[SOURce:\]VOLTage:RANGe](#).

Return Format

```
<NR3>
```

The query command returns the programmed voltage level in the form +n.nnnnnnE+nn for each channel specified. Multiple responses are separated by commas.

Examples

The following command sets the output voltage to 50 V on channels 1 and 2.

```
VOLT 50, (@1, 2)
```

The following query returns the programmed voltage level on channels 1 and 2.

```
VOLT? (@1, 2)
```

Typical Response: +5.000000E+01, +5.000000E+01

See Also

[\[SOURce:VOLTage:RANGe](#)

[SOURce:]VOLTage[:LEVel]:TRIGgered[:AMPLitude]

Syntax

```
[SOURce:]VOLTage[:LEVel]:TRIGgered[:AMPLitude]
<voltage>, (@<chanlist>)
```

```
[SOURce:]VOLTage[:LEVel]:TRIGgered[:AMPLitude]?
[MIN|MAX,] (@<chanlist>)
```

Description

This command sets the triggered voltage level of the specified output channel. Units are in volts. The triggered level is a stored value that is transferred to the output when an output Step is triggered.

Parameters

Name	Type	Range of Values	Default Value
<voltage>	NRf+	0 - maximum MIN MAX The maximum value is dependent on the voltage rating of the power module.	MIN
<chanlist>	Numeric	One or more channels. (@2) - channel 2 (@1,4) - channels 1 and 4 (@1:3) - channels 1 through 3.	Required parameter

Remarks

This command is coupled with [SOURce:]VOLTage:RANGe.

Return Format

```
<NR3>
```

The query command returns the programmed triggered level in the form +n.nnnnnnE+nn for each channel specified. Multiple responses are separated by commas.

Examples

The following command sets the triggered voltage to 40 V on channels 1 and 2.

```
VOLT:TRIG 40,(@1,2)
```

The following query returns the programmed triggered level on channels 1 and 2.

```
VOLT:TRIG? (@1,2)
```

Typical Response: +4.000000E+01,+4.000000E+01

See Also

[\[SOURCE:VOLTage\[:LEVel\]\[:IMMediate\]](#)

[\[SOURCE:VOLTage:MODE](#)

[TRIGger:TRANsient\[:IMMediate\]](#)

[SOURce:]VOLTage:BWIDth**Syntax**

```
[SOURce:]VOLTage:BWIDth <mode>, (@<chanlist>)
```

```
[SOURce:]VOLTage:BWIDth? (@<chanlist>)
```

Description

This command specifies a voltage bandwidth, which lets you optimize output response time with capacitive loads. These compensation modes only apply when the unit is operating in Voltage Priority mode. The default bandwidth is optimized for stability with a wide range of output capacitors. Three additional bandwidth modes provide faster output response when the output capacitance is restricted to the indicated values.

Bandwidth Mode	Output Capacitance	Output sensing
LOW	0 - 150 microfarads	Local or Remote
HIGH1	0 - 1 microfarads	Remote only
HIGH2	1 - 7 microfarads	Remote only
HIGH3	7 - 150 microfarads	Remote only

NOTE

This command only applies to model N678xA SMU.

Parameters

Name	Type	Range of Values	Default Value
<mode>	CPD	LOW HIGH1 HIGH2 HIGH3	LOW
<chanlist>	Numeric	One or more channels. (@2) - channel 2 (@1,4) - channels 1 and 4 (@1:3) - channels 1 through 3.	Required parameter

Remarks

The HIGH compensation modes can only be used in conjunction with remote voltage sensing.

Connecting capacitive loads that fall outside the indicated ranges will result in output instability or oscillation. If output oscillation occurs, a protection function will detect the oscillation and latch the output off. The condition is annunciated by the OSC status bit. The oscillation detect function is always enabled.

To clear the OSC protection, first remove that condition that caused the oscillation by selecting a different bandwidth mode. Then send [OUTPut:PROTEction:CLEAR](#).

Return Format

<CRD>

The query command returns the bandwidth selection for each channel specified. Multiple responses are separated by commas.

Examples

The following command sets a bandwidth selection of 1 - 7 microfarads for channel 4.

```
VOLT:BWID HIGH2 , (@4)
```

The following query returns the bandwidth selection of channel 1.

```
VOLT:BWID? (@1)
```

Typical Response: LOW

See Also

[OUTPut:PROTection:OSCillation](#)

[SOURce:]VOLTage:LIMit[:POSitive][:IMMEDIATE][:AMPLitude]**Syntax**

```
[SOURce:]VOLTage:LIMit[:POSitive][:IMMEDIATE]
[:AMPLitude] <limit>, (@<chanlist>)
```

```
[SOURce:]VOLTage:LIMit[:POSitive][:IMMEDIATE]
[:AMPLitude]? [MIN|MAX,] (@<chanlist>)
```

Description

This command sets the positive voltage limit of the specified output channel. Units are in volts. If [\[SOURce:\]VOLTage:LIMit:COUPle](#) is enabled, this command also sets the value of the negative voltage limit. Refer to Appendix E in the N6700 User's Guide under "Current Priority" for more information about voltage limit operation.

NOTE

This command only applies to model N678xA SMU.

Parameters

Name	Type	Range of Values	Default Value
<limit>	NRf+	0 - 20.4 MIN MAX	MAX (of selected range)
<chanlist>	Numeric	One or more channels. (@2) - channel 2 (@1,4) - channels 1 and 4 (@1:3) - channels 1 through 3.	Required parameter

Return Format

<NR3>

The query command returns the voltage limit in the form +n.nnnnnnE+nn for each channel specified. Multiple responses are separated by commas.

Examples

The following command sets the voltage limit to 20 V on channels 1 and 2.

```
VOLT:LIM 20, (@1,2)
```

The following query returns the voltage limit on channels 1 and 2.

```
VOLT:LIM? (@1,2)
```

Typical Response: +2.000000E+01;+2.000000E+01

See Also

[\[SOURce:\]VOLTage:LIMit:COUPle](#)

[\[SOURce:\]VOLTage:LIMit:NEGative](#)

[SOURce:]VOLTage:LIMit:COUple**Syntax**

```
[SOURce:]VOLTage:LIMit:COUple <Bool>, (@<chanlist>)
```

```
[SOURce:]VOLTage:LIMit:COUple? (@<chanlist>)
```

Description

This command sets the voltage limit tracking state. The enabled state is On (1); the disabled state is Off (0). If limit tracking is enabled, The negative voltage limit tracks the positive voltage limit setting. The [\[SOURce:\]VOLTage:LIMit](#) command sets the value of the positive and negative voltage limits.

NOTE

This command only applies to model N6784A.

Parameters

Name	Type	Range of Values	Default Value
<Bool>	Boolean	OFF 0 ON 1	OFF
<chanlist>	Numeric	One or more channels. (@2) - channel 2 (@1,4) - channels 1 and 4 (@1:3) - channels 1 through 3.	Required parameter

Return Format

```
<NR1>
```

The query command returns 1 if the voltage limit coupling is enabled, and 0 if the voltage limit coupling is disabled.

Examples

The following command sets the voltage limit coupling on for channel 4.

```
VOLT:LIM:COUP ON, (@4)
```

The following query returns the voltage limit coupling state for channel 1.

```
VOLT:LIM:COUP? (@1)
```

Typical Response: 0

See Also

[\[SOURce:\]VOLTage:LIMit](#)

[\[SOURce:\]VOLTage:LIMit:NEGative](#)

[SOURce:]VOLTage:LIMit:NEGative[:IMMEDIATE][:AMPLitude]**Syntax**

```
[SOURce:]VOLTage:LIMit:NEGative[:IMMEDIATE]
[:AMPLitude] <limit>, (@<chanlist>)
```

```
[SOURce:]VOLTage:LIMit:NEGative[:IMMEDIATE]
[:AMPLitude]? [MIN|MAX,] (@<chanlist>)
```

Description

This command sets the negative voltage limit of the specified output channel. Units are in volts. If [\[SOURce:\]VOLTage:LIMit:COUPlE](#) is enabled, this command also sets the value of the positive voltage limit. Refer to Appendix E in the N6700 User's Guide under "Current Priority" for more information about voltage limit operation.

NOTE

This command only applies to model N6784A.

Parameters

Name	Type	Range of Values	Default Value
<limit>	NRf+	-20.4 to 0 MIN MAX	MIN (of selected range)
<chanlist>	Numeric	One or more channels. (@2) - channel 2 (@1,4) - channels 1 and 4 (@1:3) - channels 1 through 3.	Required parameter

Remarks

MIN refers to the most negative value of the range. MAX refers to the least negative value of the range.

Return Format

```
<NR3>
```

The query command returns the negative voltage limit in the form +n.nnnnnnE+nn for each channel specified. Multiple responses are separated by commas.

Examples

The following command sets the negative voltage limit to -19 V on channels 1 and 3.

```
VOLT:LIM:NEG -19, (@1, 3)
```

The following query returns the negative voltage limit on channels 1 and 2.

3 Commands by Subsystem

```
VOLT:LIM:NEG? (@1,3)
```

Typical Response: -1.900000E+01,-1.900000E+01

See Also

[\[SOURCE:VOLTage:LIMit:COUPle](#)

[\[SOURCE:VOLTage:LIMit](#)

[SOURce:]VOLTage:MODE**Syntax**

```
[SOURce:]VOLTage:MODE <mode>, (@<chanlist>)
```

```
[SOURce:]VOLTage:MODE? (@<chanlist>)
```

Description

This command determines what happens to the output voltage when the transient system is initiated and triggered.

FIXed The output voltage remains at the immediate value.

STEP The output goes to the triggered level when a trigger occurs.

LIST The output follows the programmed list values when a trigger occurs.

NOTE

List mode is only available with models N6761A/N6762A, or models that have Option 054 (High Speed Test Extensions).

Parameters

Name	Type	Range of Values	Default Value
<mode>	CPD	FIXed STEP LIST	FIXed
<chanlist>	Numeric	One or more channels. (@2) - channel 2 (@1,4) - channels 1 and 4 (@1:3) - channels 1 through 3.	Required parameter

Return Format

```
<CRD>
```

The query command returns the voltage mode for each channel specified. Multiple responses are separated by commas.

Examples

The following command sets the voltage mode of channel 4.

```
VOLT:MODE STEP, (@4)
```

The following query returns the voltage mode of channel 1.

```
VOLT:MODE? (@4)
```

Typical Response: FIX

See Also

[\[SOURce:\]CURRENT:MODE](#)

[INITiate\[:IMMediate\]:TRANSient](#)

[TRIGger:TRANSient\[:IMMediate\]](#)

[SOURce:]VOLTage:PROTection[:LEVel]**Syntax**

```
[SOURce:]VOLTage:PROTection[:LEVel] <voltage>,
(@<chanlist>)
```

```
[SOURce:]VOLTage:PROTection[:LEVel]? [MIN|MAX,]
(@<chanlist>)
```

Description

This command sets the over-voltage protection (OVP) level of the output channel. The values are programmed in volts. If the output voltage exceeds the OVP level, the output is disabled and the Questionable Condition status register OV bit is set. The output voltage is monitored at the + output and – output terminals.

Parameters

Name	Type	Range of Values	Default Value
<voltage>	NRf+	0 - maximum MIN MAX The maximum value is dependent on the voltage rating of the power module.	MAX
<chanlist>	Numeric	One or more channels. (@2) - channel 2 (@1,4) - channels 1 and 4 (@1:3) - channels 1 through 3.	Required parameter

Remarks

An over-voltage condition can be cleared with the OUTput:PROTection:CLEar command after the condition that caused the OVP trip is removed.

Return Format

```
<NR3>
```

The query command returns the programmed protection level in the form +n.nnnnnnE+nn for each channel specified. Multiple responses are separated by commas.

Examples

The following command sets the voltage protection level to 45 V on channel 1.

```
VOLT:PROT 45,(@1)
```

The following query returns the programmed voltage protection level on channel 1.

```
VOLT:PROT? (@1)
```

Typical Response: +4.500000E+01

See Also

[OUTPut:PROTection:CLEar](#)

[SOURce:]VOLTage:PROTection:DELay[:TIME]**Syntax**

```
[SOURce:]VOLTage:PROTection:DELay[:TIME] <time>,
(@<chanlist>)
```

```
[SOURce:]VOLTage:PROTection:DELay[:TIME]? [MIN|MAX,]
(@<chanlist>)
```

Description

This command sets the over-voltage protection delay. The over-voltage protection function will not be triggered on the specified output channel during the delay time. After the delay time has expired, the over-voltage protection function will be active. This prevents momentary changes in output status from triggering the over-current protection function. Programmed values can range from 60 microseconds to 5 milliseconds with a resolution of 20.48 microseconds.

NOTE

This command only applies to models N6783A.

Parameters

Name	Type	Range of Values	Default Value
<voltage>	NRf+	60 μ s - 5 ms MIN MAX The maximum value is dependent on the voltage rating of the power module.	0 (zero)
<chanlist>	Numeric	One or more channels. (@2) - channel 2 (@1,4) - channels 1 and 4 (@1:3) - channels 1 through 3.	Required parameter

Return Format

```
<NR3>
```

The query command returns the programmed delay time. The reading is in the form +n.nnnnnnE+nn.

Examples

The following command sets the voltage protection delay to 1 millisecond on channel 1.

```
VOLT:PROT:DEL 0.001,(@1)
```

The following query returns the programmed voltage protection delay on channel 1.

```
VOLT:PROT:DEL? (@1)
```

Typical Response: +1.000000E-03

See Also

[OUTPut:PROTection:CLEar](#)

[SOURce:]VOLTage:PROTection:REMOte[:POSitive][:LEVel]**Syntax**

```
[SOURce:]VOLTage:PROTection:REMOte[:POSitive][:LEVel]
<voltage>, (@<chanlist>)
```

```
[SOURce:]VOLTage:PROTection:REMOte[:POSitive][:LEVel]
]? [MIN|MAX,] (@<chanlist>)
```

Description

This command sets the positive over-voltage remote protection (OVP) level of the output channel. The values are programmed in volts. If the output voltage exceeds the OVP level, the output is disabled and the Questionable Condition status register OV bit is set.

For Models N678xA only, the OVP circuit senses the 4-wire sense terminals rather than the output terminals. This allows for more precise overvoltage monitoring directly at the load. Since incorrect sense terminal wiring such as reversed or open sense wires could defeat this feature, the OVP will automatically trip if the voltage at the output terminals rises more than 1.5 V above the voltage at the sense terminals.

NOTE

This command only applies to models N678xA SMU.

Parameters

Name	Type	Range of Values	Default Value
<voltage>	NRf+	0 - 22 MIN MAX	MAX
<chanlist>	Numeric	One or more channels. (@2) - channel 2 (@1,4) - channels 1 and 4 (@1:3) - channels 1 through 3.	Required parameter

Remarks

An over-voltage condition can be cleared with the OUTput:PROTection:CLEar command after the condition that caused the OVP trip is removed.

Return Format

```
<NR3>
```

The query command returns the over-voltage remote protection level in the form +n.nnnnnnE+nn for each channel specified. Multiple responses are separated by commas.

Examples

The following command sets the over-voltage remote protection level to 15 V on channel 1.

```
VOLT:PROT:REM 15, (@1)
```

The following query returns the over-voltage remote protection level on channel 1.

```
VOLT:PROT:REM? (@1)
```

Typical Response: +1.500000E+01

See Also

[OUTPut:PROTection:CLEAr](#)

[\[SOURce:\]VOLTage:PROTection:REMote:NEGative](#)

[SOURce:]VOLTage:PROTection:REMOte:NEGAtive[:LEVel]**Syntax**

```
[SOURce:]VOLTage:PROTection:REMOte:NEGAtive[:LEVel]
<voltage>, (@<chanlist>)
```

```
[SOURce:]VOLTage:PROTection:REMOte:NEGAtive[:LEVel]
? [MIN|MAX,] (@<chanlist>)
```

Description

This command sets the negative over-voltage remote protection (OVP) level of the output channel. The values are programmed in volts. If the output voltage exceeds the OVP level, the output is disabled and the Questionable Condition status register OV bit is set.

For Models N678xA only, the OVP circuit senses the 4-wire sense terminals rather than the output terminals. This allows for more precise overvoltage monitoring directly at the load. Since incorrect sense terminal wiring such as reversed or open sense wires could defeat this feature, the OVP will automatically trip if the voltage at the output terminals rises more than 1.5 V above the voltage at the sense terminals.

NOTE

This command only applies to model N6784A.

Parameters

Name	Type	Range of Values	Default Value
<voltage>	NRf+	-22 to 0 MIN MAX	MIN
<chanlist>	Numeric	One or more channels. (@2) - channel 2 (@1,4) - channels 1 and 4 (@1:3) - channels 1 through 3.	Required parameter

Remarks

An over-voltage condition can be cleared with the OUTput:PROTection:CLEar command after the condition that caused the OVP trip is removed.

MIN refers to the most negative value of the range. MAX refers to the least negative value of the range.

Return Format

```
<NR3>
```

The query command returns the negative over-voltage remote protection level in the form +n.nnnnnnE+nn for each channel specified. Multiple responses are separated by commas.

Examples

The following command sets the negative over-voltage remote protection level to -15 V on channel 1.

```
VOLT:PROT:REM:NEG -15,(@1)
```

The following query returns the negative over-voltage remote protection level on channel 1.

```
VOLT:PROT:REM:NEG? (@1)
```

Typical Response: -1.500000E+01

See Also

[OUTPut:PROTection:CLEar](#)

[\[SOURce:\]VOLTage:PROTection:REMOte](#)

[SOURce:]VOLTage:PROTection:TRACking[:STATe]**Syntax**

```
[SOURce:]VOLTage:PROTection:TRACking[:STATe] <Bool>,
(@<chanlist>)
```

```
[SOURce:]VOLTage:PROTection:TRACking[:STATe]?
(@<chanlist>)
```

Description

This command enables or disables the tracking over-voltage protection (OVP) function of the output channel.

NOTE

This command is only available on models N6752A, N6754A, and N6762A with Option J01.

Parameters

Name	Type	Range of Values	Default Value
<Bool>	Boolean	OFF 0 ON 1	OFF
<chanlist>	Numeric	One or more channels. (@2) - channel 2 (@1,4) - channels 1 and 4 (@1:3) - channels 1 through 3.	Required parameter

Remarks

An over-voltage condition can be cleared with the OUTput:PROTection:CLEar command after the condition that caused the OVP trip is removed.

Return Format

```
<NR1>
```

The query command returns 0 if the tracking OVP is OFF, and 1 if the tracking OVP is ON.

Examples

The following command sets the tracking OVP function on channel 1.

```
VOLT:PROT:TRAC ON, (@1)
```

The following query returns the tracking OVP setting on channel 1.

```
VOLT:PROT:TRAC? (@1)
```

Typical Response: 0

See Also

[OUTPut:PROTection:CLEar](#)

[\[SOURce:|VOLTage:PROTection:TRACking:OFFSet](#)

[SOURce:]VOLTage:PROTection:TRACking:OFFSet**Syntax**

```
[SOURce:]VOLTage:PROTection:TRACking:OFFSet
<voltage>, (@<chanlist>)
```

```
[SOURce:]VOLTage:PROTection:TRACking:OFFSet?
[MIN|MAX,] (@<chanlist>)
```

Description

This command set the tracking over-voltage protection (OVP) offset of the output channel. This lets you set an overvoltage protection limit that is an offset from the programmed voltage. This is an addition to the existing overvoltage limit. The tracking OVP threshold automatically tracks the programmed output setting. The output voltage is monitored at the + sense and - sense terminals.

NOTE

This command is only available on models N6752A, N6754A, and N6762A with Option J01.

Parameters

Name	Type	Range of Values	Default Value
<voltage>	Nrf+	0 - maximum MIN MAX The maximum value is dependent on the voltage rating of the power module.	MAX
<chanlist>	Numeric	One or more channels. (@2) - channel 2 (@1,4) - channels 1 and 4 (@1:3) - channels 1 through 3.	Required parameter

Remarks

An over-voltage condition can be cleared with the OUTput:PROTection:CLEar command after the condition that caused the OVP trip is removed.

Return Format

```
<NR3>
```

The query command returns the programmed offset voltage in the form +n.nnnnnnE+nn for each channel specified. Multiple responses are separated by commas.

Examples

The following command sets the tracking OVP offset to 2 volts on channel 1.

```
VOLT:PROT:TRAC:OFFS 2,(@1)
```

The following query returns the tracking OVP offset on channel 1.

```
VOLT:PROT:TRAC:OFFS? (@1)
```

Typical Response: +2.000000E+01

See Also

[OUTPut:PROTection:CLEar](#)

[\[SOURce:\]VOLTage:PROTection:TRACking\[:STATe\]](#)

[SOURce:]VOLTage:RANGe**Syntax**

```
[SOURce:]VOLTage:RANGe <range>, (@<chanlist>)
```

```
[SOURce:]VOLTage:RANGe? [MIN|MAX,] (@<chanlist>)
```

Description

This command sets the output voltage range on models that have multiple ranges. The value that you enter must be the highest value in volts that you expect to source. The instrument selects the range with the best resolution for the value entered.

Parameters

Name	Type	Range of Values	Default Value
<range>	NRf+	0 - maximum MIN MAX Values entered are model dependent.	MAX
<chanlist>	Numeric	One or more channels. (@2) - channel 2 (@1,4) - channels 1 and 4 (@1:3) - channels 1 through 3.	Required parameter

Remarks

This command is coupled with the [SOURce:]VOLTage command. This means that if a range command is sent that places an output on a range with a lower maximum voltage than the present voltage level, an error is generated. This also occurs if a voltage level is programmed with a value too large for the present range.

These types of errors can be avoided by sending the both level and range commands in the same SCPI message. When the range and setting information is received as a set, no range/setting conflict occurs.

If programming a range value causes a range change to occur while the output is enabled, the output will be temporarily disabled while the range switch occurs. The transition from on-to-off and then from off-to-on will also be delayed by the settings of OUTPut:DELAy:FALL and OUTPut:DELAy:RISE.

Return Format

```
<NR3>
```

The query command returns the maximum voltage that can be output on the range that is presently set. The voltage level is in the form +n.nnnnnnE+nn for each channel specified. Multiple responses are separated by commas.

Examples

The following command sets the output voltage range to 5 V on channels 1 and 2.

```
VOLT:RANG 5, (@1, 2)
```

The following query returns the programmed voltage range on channels 1 and 2.

```
VOLT:RANG? (@1, 2)
```

Typical Response: +5.500000E+00, +5.500000E+00

See Also

[\[SOURCE:VOLTage\[:LEVel\]\[:IMMediate\]](#)

[SOURce:]VOLTage:SLEW[:IMMediate]**Syntax**

```
[SOURce:]VOLTage:SLEW[:IMMediate] <slew>|INFinity,
(@<chanlist>)
```

```
[SOURce:]VOLTage:SLEW[:IMMediate]? [MIN|MAX, ]
(@<chanlist>)
```

Description

This command sets the voltage slew rate in volts per second. The slew rate setting affects all programmed voltage changes, including those due to the output state turning on or off. The slew rate can be set to any value between 0 and 9.9E+37. For very large values, the slew rate will be limited by the analog performance of the output circuit. The keywords MAX or INFinity set the slew rate to maximum.

The query returns the value that was sent, unless the value was less than the minimum slew rate, in which case the minimum value is returned. The LSB weight of the 24-bit register can be queried using [SOURce:]VOLTage:SLEW? MIN. The exact value varies slightly according to the voltage calibration.

Parameters

Name	Type	Range of Values	Default Value
<slew>	NRf+	0 - 9.9E+37 MIN MAX INFinity	9.9E+37
<chanlist>	Numeric	One or more channels. (@2) - channel 2 (@1,4) - channels 1 and 4 (@1:3) - channels 1 through 3.	Required parameter

Remarks

Internally, the slew rate is controlled by a 24-bit register. The slowest or minimum slew rate is a function of the full-scale voltage range. For a model with a 50 V range, the minimum slew rate is about 4.76 V/s. For other voltage ranges the minimum slew rate is proportional to this value, so for a model with a 5 V range the minimum slew rate is about 0.476 V/s. The unit accepts slew rates as low as 0 V/s, but values sent to the 24-bit register will be limited at 1 count.

Return Format

```
<NR3>
```

The query command returns the programmed slew rate in the form +n.nnnnnnE+nn for each channel specified. Multiple responses are separated by commas. If a slew rate of 9.9E37 is returned, it means that the maximum or fastest slew rate has been set.

Examples

The following command sets the slew rate to 5 volts per second on channel 1.

```
VOLT:SLEW 5,(@1)
```

The following query returns the programmed slew rate on channel 1.

```
VOLT:SLEW? (@1)
```

Typical Response: +5.000000E+00

See Also

[\[SOURCE:|CURRENT:SLEW](#)

[\[SOURCE:|VOLTage:SLEW:MAXimum](#)

[SOURce:]VOLTage:SLEW:MAXimum**Syntax**

```
[SOURce:]VOLTage:SLEW:MAXimum <Bool>, (@<chanlist>)
[SOURce:]VOLTage:SLEW:MAXimum? (@<chanlist>)
```

Description

This command sets the voltage slew rate maximum override. When enabled (ON), the power module's slew rate is set to its maximum value. When disabled (OFF), the power module's slew rate is set to the immediate value set by the [SOURce:]VOLTage:SLEW command. [SOURce:]VOLTage:SLEW:MAX does not affect the [SOURce:]VOLTage:SLEW setting.

Use [SOURce:]VOLTage:SLEW? MAX to query the maximum slew rate that was set.

Parameters

Name	Type	Range of Values	Default Value
<Bool>	Boolean	OFF 0 ON 1	OFF
<chanlist>	Numeric	One or more channels. (@2) - channel 2 (@1,4) - channels 1 and 4 (@1:3) - channels 1 through 3.	Required parameter

Remarks

The [SOURce:]VOLTage:SLEW:MAX command is coupled to the [SOURce:]VOLTage:SLEW command. If [SOURce:]VOLTage:SLEW sets the rate to MAX or INFINITY, [SOURce:]VOLTage:SLEW:MAX is enabled. If the slew rate is set to any other value, [SOURce:]VOLTage:SLEW:MAX is disabled.

Return Format

```
<NR1>
```

The query command returns 0 if the slew rate override is disabled, and 1 if the slew rate override is enabled.

Examples

The following command enables the slew rate maximum override on channel 1.

```
VOLT:SLEW:MAX ON, (@1)
```

The following query returns the state of the slew rate override on channel 1.

```
VOLT:SLEW:MAX? (@1)
```

Typical Response: 1

See Also

[\[SOURCE:VOLTage:SLEW](#)

[\[SOURCE:CURRENT:SLEW:MAXimum](#)

STATus Subsystem Introduction

Status register programming lets you determine the operating condition of the instrument at any time. The instrument has three groups of status registers; Operation, Questionable, and Standard Event. The Operation and Questionable status groups each consist of the Condition, Enable, and Event registers as well as NTR and PTR filters.

The Status subsystem is also programmed using Common commands. Common commands control additional status functions such as the Service Request Enable and the Status Byte registers.

Refer to the [Status System diagram](#).

SCPI Command	Description
STATus	
:OPERation	
[:EVENT]? (@chanlist)	Returns the value of the operation event register
:CONDition? (@chanlist)	Returns the value of the operation condition register
:ENABle <NRf>, (@chanlist)	Enables specific bits in the Event register
:NTRansition <NRf>, (@chanlist)	Sets the Negative transition filter
:PTRansition <NRf>, (@chanlist)	Sets the Positive transition filter
:PRESet	Presets all enable and transition registers to power-on
:QUEStionable	
[:EVENT]? (@chanlist)	Returns the value of the questionable event register
:CONDition? (@chanlist)	Returns the value of the questionable condition register
:ENABle <NRf>, (@chanlist)	Enables specific bits in the Event register
:NTRansition <NRf>, (@chanlist)	Sets the Negative transition filter
:PTRansition <NRf>, (@chanlist)	Sets the Positive transition filter

Operation Status Group

These registers record signals that occur during normal operation. The group consists of a Condition, PTR/NTR, Event, and Enable register. The outputs of the Operation Status register group are logically-ORed into the OPERation summary bit (7) of the Status Byte register.

Questionable Status Group

These registers record signals that indicate abnormal operation. The group consists of the same register types as the Operation Status group. The outputs of the Questionable Status group are logically-ORed into the QUEStionable summary bit (3) of the Status Byte register.

Standard Event Status Group

These registers are programmed by Common commands. The Standard Event event register latches events relating to communication status. It is a read-only register that is cleared when read. The Standard Event enable register functions similarly to the enable registers of the Operation and Questionable status groups.

Status Byte Register

This register summarizes the information from all other status groups as defined in the *IEEE 488.2 Standard Digital Interface for Programmable Instrumentation*.

MSS and RQS Bits

MSS is a real-time (unlatched) summary of all Status Byte register bits that are enabled by the Service Request Enable register. MSS is set whenever the instrument has one or more reasons for requesting service. *STB? reads the MSS in bit position 6 of the response but does not clear any of the bits in the Status Byte register.

The RQS bit is a latched version of the MSS bit. Whenever the instrument requests service, it sets the SRQ interrupt line true and latches RQS into bit 6 of the Status Byte register. When the controller does a serial poll, RQS is cleared inside the register and returned in bit position 6 of the response. The remaining bits of the Status Byte register are not disturbed.

MAV Bit and Output Queue

The Output Queue is a first-in, first-out (FIFO) data register that stores instrument-to-controller messages until the controller reads them. Whenever the queue holds one or more bytes, it sets the MAV bit (4) of the Status Byte register.

Status System Diagram

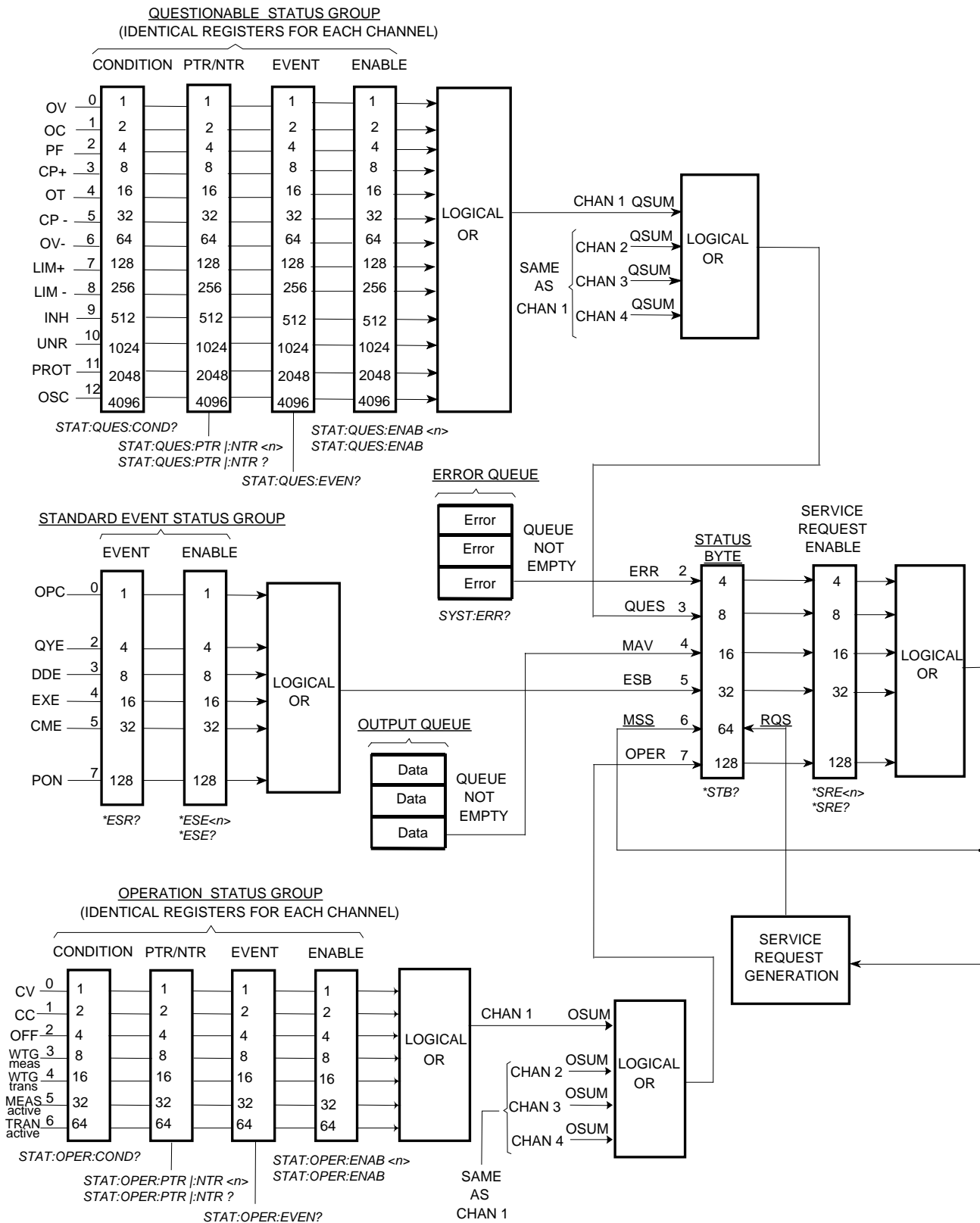

STATus:OPERation[:EVENT]?

Syntax

STATus:OPERation[:EVENT]? (@<chanlist>)

Description

This query returns the value of the Operation Status Event register. The Event register is a read-only register, which stores (latches) all events that are passed by the Operation NTR and/or PTR filter. Reading the Operation Status Event register clears it.

NOTE

For more information on the SCPI Status System, see the [Status System diagram](#)

Parameters

Name	Type	Range of Values	Default Value
<chanlist>	Numeric	One or more channels. (@2) - channel 2 (@1,4) - channels 1 and 4 (@1:3) - channels 1 through 3.	Required parameter

Remarks

The following table lists the bit definitions for the Operation Status registers.

Bit Number		Decimal Value	Definition
0	CV	1	The output is in constant voltage.
1	CC	2	The output is in constant current.
2	OFF	4	The output is programmed off.
3	WTG-meas	8	The measurement system is waiting for a trigger.
4	WTG-tran	16	The transient system is waiting for a trigger.
5	MEAS-active	32	The measurement system is initiated.
6	TRAN-active	64	The transient system is initiated.
7-15	Not Used	Not Used	0 is returned.

Once a bit is set, it remains set until cleared by reading the event register or the [*CLS](#) (clear status) command.

Return Format

<NR1>

The value returned is the binary-weighted sum of all bits set in the register. For example, if bit 3 (decimal value = 8) and bit 4 (decimal value = 16) are set, this command will return 24.

Example

The following command reads the Operation Status Event register.

```
STAT:OPER? (@1)
```

Typical Response: +24

See Also

[STATus:OPERation:ENABLE](#)

[*CLS](#)

STATus:OPERation:CONDition?

Syntax

STATus:OPERation:CONDition? (@<chanlist>)

Description

This query returns the value of the Operation Status Condition register. The Condition register is a read-only register, which holds the live (unlatched) operational status of the instrument. Reading the Operation Condition register does not clear it.

NOTE

For more information on the SCPI Status System, see the [Status System diagram](#)

Parameters

Name	Type	Range of Values	Default Value
<chanlist>	Numeric	One or more channels. (@2) - channel 2 (@1,4) - channels 1 and 4 (@1:3) - channels 1 through 3.	Required parameter

Remarks

The following table lists the bit definitions for the Operation Status registers.

Bit Number	Decimal Value	Definition
0 CV	1	The output is in constant voltage.
1 CC	2	The output is in constant current.
2 OFF	4	The output is programmed off.
3 WTG-meas	8	The measurement system is waiting for a trigger.
4 WTG-tran	16	The transient system is waiting for a trigger.
5 MEAS-active	32	The measurement system is initiated.
6 TRAN-active	64	The transient system is initiated.
7-15 Not Used	Not Used	0 is returned.

Return Format

<NR1>

The value returned is the binary-weighted sum of all bits set in the register. For example, if bit 3 (decimal value = 8) and bit 4 (decimal value = 16) are set, this command will return 24.

Example

The following command reads the Operation Status Condition register.

```
STAT:OPER:COND? (@1)
```

Typical Response: +24

STATus:OPERation:ENABLE

Syntax

STATus:OPERation:ENABLE <value>, (@<chanlist>)

STATus:OPERation:ENABLE? (@<chanlist>)

Description

This command and its query set and read the value of the Operation Status Enable register. The Enable register is a mask for enabling specific bits from the Operation Event register to set the operation summary bit (OPER) of the Status Byte register. This bit (bit 7) is the logical OR of all the Operational Event register bits that are enabled by the Operation Status Enable register.

NOTE

For more information on the SCPI Status System, see the [Status System diagram](#)

Parameters

Name	Type	Range of Values	Default Value
<value>	NR1	A decimal value which corresponds to the binary-weighted sum of the bits in the register (see table below).	Preset = 0
<chanlist>	Numeric	One or more channels. (@2) - channel 2 (@1,4) - channels 1 and 4 (@1:3) - channels 1 through 3.	Required parameter

For example, to enable bit 3 (decimal value = 8) and bit 4 (decimal value = 16), the corresponding decimal value would be 24 (8 + 16).

Remarks

The following table lists the bit definitions for the Operation Status registers.

Bit Number	Decimal Value	Definition
0 CV	1	The output is in constant voltage.
1 CC	2	The output is in constant current.
2 OFF	4	The output is programmed off.
3 WTG-meas	8	The measurement system is waiting for a trigger.
4 WTG-tran	16	The transient system is waiting for a trigger.
5 MEAS-active	32	The measurement system is initiated.
6 TRAN-active	64	The transient system is initiated.
7-15 Not Used	Not Used	0 is returned.

The [STATus:PRESet](#) command will clear all bits in the enable register.

Return Format

<NR1>

The value returned is the binary-weighted sum of all bits set in the register. For example, if bit 3 (decimal value = 8) and bit 4 (decimal value = 16) are set, this command will return 24.

Examples

The following command enables bits 0 and 1 (decimal value = 3) in the enable register.

```
STAT:OPER:ENAB 3, (@1)
```

The following query returns which bits are enabled in the register.

```
STAT:OPER:ENAB? (@1)
```

Typical Response: +3

See Also

[STATus:OPERation\[:EVENT\]?](#)

[STATus:PRESet](#)

STATus:OPERation:NTRansition

Syntax

STATus:OPERation:NTRansition <value>, (@<chanlist>)

STATus:OPERation:NTRansition? (@<chanlist>)

Description

These command sets and reads the value of the Operation NTR (Negative-Transition) register. This register serves as a polarity filter between the Operation Condition and Operation Event registers. When a bit in the Operation NTR register is set to 1, then a 1-to-0 transition of the corresponding bit in the Operation Condition register causes that bit in the Operation Event register to be set.

NOTE

For more information on the SCPI Status System, see the [Status System diagram](#)

Parameters

Name	Type	Range of Values	Default Value
<value>	NR1	A decimal value which corresponds to the binary-weighted sum of the bits in the register (see table below).	Preset = 0
<chanlist>	Numeric	One or more channels. (@2) - channel 2 (@1,4) - channels 1 and 4 (@1:3) - channels 1 through 3.	Required parameter

For example, to enable bit 3 (decimal value = 8) and bit 4 (decimal value = 16), the corresponding decimal value would be 24 (8 + 16).

Remarks

The following table lists the bit definitions for the Operation Status registers.

Bit Number	Decimal Value	Definition
0 CV	1	The output is in constant voltage.
1 CC	2	The output is in constant current.
2 OFF	4	The output is programmed off.
3 WTG-meas	8	The measurement system is waiting for a trigger.
4 WTG-tran	16	The transient system is waiting for a trigger.
5 MEAS-active	32	The measurement system is initiated.
6 TRAN-active	64	The transient system is initiated.
7-15 Not Used	Not Used	0 is returned.

If the same bits in both NTR and PTR registers are set to 1, then any transition of that bit at the Operation Condition register sets the corresponding bit in the Operation Event register.

If the same bits in both NTR and PTR registers are set to 0, then no transition of that bit at the Operation Condition register can set the corresponding bit in the Operation Event register.

The [STATus:PRESet](#) command will set all bits in the NTR register to 0.

Return Format

<NR1>

The value returned is the binary-weighted sum of all bits set in the register.

Examples

The following command enables bits 0 and 1 (decimal value = 3) in the NTR register.

```
STAT:OPER:NTR 3, (@1)
```

The following query returns which bits are enabled in the register.

```
STAT:OPER:NTR? (@1)
```

Typical Response: +3

See Also

[STATus:OPERation:PTRansition](#)

[STATus:PRESet](#)

STATus:OPERation:PTRansition

Syntax

STATus:OPERation:PTRansition <value>, (@<chanlist>)

STATus:OPERation:PTRansition? (@<chanlist>)

Description

These command sets and reads the value of the Operation PTR (Positive-Transition) register. This register serves as a polarity filter between the Operation Condition and Operation Event registers. When a bit in the Operation PTR register is set to 1, then a 0-to-1 transition of the corresponding bit in the Operation Condition register causes that bit in the Operation Event register to be set.

NOTE

For more information on the SCPI Status System, see the [Status System diagram](#)

Parameters

Name	Type	Range of Values	Default Value
<value>	NR1	A decimal value which corresponds to the binary-weighted sum of the bits in the register (see table below).	Preset = 127
<chanlist>	Numeric	One or more channels. (@2) - channel 2 (@1,4) - channels 1 and 4 (@1:3) - channels 1 through 3.	Required parameter

For example, to enable bit 3 (decimal value = 8) and bit 4 (decimal value = 16), the corresponding decimal value would be 24 (8 + 16).

Remarks

The following table lists the bit definitions for the Operation Status registers.

Bit Number	Decimal Value	Definition
0 CV	1	The output is in constant voltage.
1 CC	2	The output is in constant current.
2 OFF	4	The output is programmed off.
3 WTG-meas	8	The measurement system is waiting for a trigger.
4 WTG-tran	16	The transient system is waiting for a trigger.
5 MEAS-active	32	The measurement system is initiated.
6 TRAN-active	64	The transient system is initiated.
7-15 Not Used	Not Used	0 is returned.

If the same bits in both NTR and PTR registers are set to 1, then any transition of that bit at the Operation Condition register sets the corresponding bit in the Operation Event register.

If the same bits in both NTR and PTR registers are set to 0, then no transition of that bit at the Operation Condition register can set the corresponding bit in the Operation Event register.

The [STATus:PRESet](#) command will set all bits in the PTR register to 1.

Return Format

<NR1>

The value returned is the binary-weighted sum of all bits set in the register.

Examples

The following command enables bits 0 and 1 (decimal value = 3) in the PTR register.

```
STAT:OPER:PTR 3, (@1)
```

The following query returns which bits are enabled in the register.

```
STAT:OPER:PTR? (@1)
```

Typical Response: +3

See Also

[STATus:OPERation:NTRansition](#)

[STATus:PRESet](#)

STATus:PRESet**Syntax**

```
STATus:PRESet
```

Description

This command sets all defined bits in the status system's PTR registers and clears all bits in the NTR and Enable registers.

Operation Register	Questionable Register	Preset setting
STAT:OPER:ENAB	STAT:QUES:ENAB	0 - all bits disabled
STAT:OPER:NTR	STAT:QUES:NTR	0 - all bits disabled
STAT:OPER:PTR		127 all defined bits enabled
	STAT:QUES:PTR	8191 all defined bits enabled

Example

The following command presets the Operation and Questionable status registers.

```
STAT:PRES
```

STATus:QUEStionable[:EVENT]?**Syntax**

STATus:QUEStionable[:EVENT]? (@<chanlist>)

Description

This query returns the value of the Questionable Status Event register. The Event register is a read-only register, which stores (latches) all events that are passed by the Questionable NTR and/or PTR filter. Reading the Questionable Status Event register clears it.

NOTE

For more information on the SCPI Status System, see the [Status System diagram](#)

Parameters

Name	Type	Range of Values	Default Value
<chanlist>	Numeric	One or more channels. (@2) - channel 2 (@1,4) - channels 1 and 4 (@1:3) - channels 1 through 3.	Required parameter

Remarks

The following table lists the bit definitions for the Questionable Status registers.

Bit Number	Decimal Value	Definition
0 OV	1	The output is disabled by the over-voltage protection.
1 OC	2	The output is disabled by the over-current protection.
2 PF	4	The output is disabled by the power-fail - which may be caused by a low-line or brownout condition on the AC line.
3 CP+	8	The output is limited (or disabled) by the positive power limit.
4 OT	16	The over-temperature protection has tripped.
5 CP-	32	The output is limited by the negative power limit.
6 OV-	64	The negative over-voltage protection has tripped.
7 LIM+	128	The output is in positive voltage or current limit.
8 LIM-	256	The output is in negative voltage or current limit.
9 INH	512	The output is inhibited by an external signal.
10 UNR	1024	The output is unregulated.
11 PROT	2048	The output has been disabled because it is coupled to a protection condition that occurred on another channel.
12 OSC	4096	The oscillation detector has tripped.
13-15 Not Used	Not Used	0 is returned.

Once a bit is set, it remains set until cleared by reading the event register or the [*CLS](#) (clear status) command.

Return Format

<NR1>

The value returned is the binary-weighted sum of all bits set in the register. For example, if bit 10 is set, this command will return 1024.

Example

The following command reads the Questionable Status Event register.

```
STAT:QUES?
```

Typical Response: +1024

See Also

[STATus:QUEStionable:ENABle?](#)

[*CLS](#)

STATus:QUEStionable:CONDition?

Syntax

STATus:QUEStionable:CONDition? (@<chanlist>)

Description

This query returns the value of the Questionable Status Condition register. The Condition register is a read-only register, which holds the live (unlatched) questionable status of the instrument. Reading the Questionable Condition register does not clear it.

NOTE

For more information on the SCPI Status System, see the [Status System diagram](#)

Parameters

Name	Type	Range of Values	Default Value
<chanlist>	Numeric	One or more channels. (@2) - channel 2 (@1,4) - channels 1 and 4 (@1:3) - channels 1 through 3.	Required parameter

Remarks

The following table lists the bit definitions for the Questionable Status registers.

Bit Number	Decimal Value	Definition
0 OV	1	The output is disabled by the over-voltage protection.
1 OC	2	The output is disabled by the over-current protection.
2 PF	4	The output is disabled by the power-fail - which may be caused by a low-line or brownout condition on the AC line.
3 CP+	8	The output is limited (or disabled) by the positive power limit.
4 OT	16	The over-temperature protection has tripped.
5 CP-	32	The output is limited by the negative power limit.
6 OV-	64	The negative over-voltage protection has tripped.
7 LIM+	128	The output is in positive voltage or current limit.
8 LIM-	256	The output is in negative voltage or current limit.
9 INH	512	The output is inhibited by an external signal.
10 UNR	1024	The output is unregulated.
11 PROT	2048	The output has been disabled because it is coupled to a protection condition that occurred on another channel.
12 OSC	4096	The oscillation detector has tripped.
13-15 Not Used	Not Used	0 is returned.

Return Format

<NR1>

The value returned is the binary-weighted sum of all bits set in the register. For example, if bit 10 is set, this command will return 1024.

Example

The following command reads the Questionable Status Condition register.

```
STAT:QUES:COND? (@1)
```

Typical Response: +1024

STATus:QUEStionable:ENABle

Syntax

```
STATus:QUEStionable:ENABle <value>, (@<chanlist>)
```

```
STATus:QUEStionable:ENABle? (@<chanlist>)
```

Description

This command and its query set and read the value of the Questionable Status Enable register. The Enable register is a mask for enabling specific bits from the Questionable Event register to set the questionable summary bit (QUES) of the Status Byte register. This bit (bit 3) is the logical OR of all the Questionable Event register bits that are enabled by the Questionable Status Enable register.

NOTE

For more information on the SCPI Status System, see the [Status System diagram](#)

Parameters

Name	Type	Range of Values	Default Value
<value>	NR1	A decimal value which corresponds to the binary-weighted sum of the bits in the register (see table below).	Preset = 0
<chanlist>	Numeric	One or more channels. (@2) - channel 2 (@1,4) - channels 1 and 4 (@1:3) - channels 1 through 3.	Required parameter

For example, to enable bit 3 (decimal value = 8) and bit 5 (decimal value = 32), the corresponding decimal value would be 40 (8 + 32).

Remarks

The following table lists the bit definitions for the Questionable Status registers.

Bit Number	Decimal Value	Definition
0 OV	1	The output is disabled by the over-voltage protection.
1 OC	2	The output is disabled by the over-current protection.
2 PF	4	The output is disabled by the power-fail - which may be caused by a low-line or brownout condition on the AC line.
3 CP+	8	The output is limited (or disabled) by the positive power limit.
4 OT	16	The over-temperature protection has tripped.
5 CP-	32	The output is limited by the negative power limit.
6 OV-	64	The negative over-voltage protection has tripped.

Bit Number		Decimal Value	Definition
7	LIM+	128	The output is in positive voltage or current limit.
8	LIM-	256	The output is in negative voltage or current limit.
9	INH	512	The output is inhibited by an external signal.
10	UNR	1024	The output is unregulated.
11	PROT	2048	The output has been disabled because it is coupled to a protection condition that occurred on another channel.
12	OSC	4096	The oscillation detector has tripped.
13-15	Not Used	Not Used	0 is returned.

The [STATus:PRESet](#) command will clear all bits in the enable register.

Return Format

<NR1>

The value returned is the binary-weighted sum of all bits set in the register.

Examples

The following command enables bits 0 and 1 (decimal value = 3) in the enable register.

```
STAT:QUES:ENAB 3, (@1)
```

The following query returns which bits are enabled in the register.

```
STAT:QUES:ENAB? (@1)
```

Typical Response: +3

See Also

[STATus:QUESTIONable\[:EVENT\]?](#)

[STATus:PRESet](#)

STATUS:QUESTIONABLE:NTRANSITION

Syntax

```
STATUS:QUESTIONABLE:NTRANSITION <value>,
(@<chanlist>)
```

```
STATUS:QUESTIONABLE:NTRANSITION? (@<chanlist>)
```

Description

These command sets and reads the value of the Questionable NTR (Negative-Transition) register. This register serves as a polarity filter between the Questionable Condition and Questionable Event registers.

When a bit in the Questionable NTR register is set to 1, then a 1-to-0 transition of the corresponding bit in the Questionable Condition register causes that bit in the Questionable Event register to be set.

NOTE

For more information on the SCPI Status System, see the [Status System diagram](#)

Parameters

Name	Type	Range of Values	Default Value
<value>	NR1	A decimal value which corresponds to the binary-weighted sum of the bits in the register (see table below).	Preset = 0
<chanlist>	Numeric	One or more channels. (@2) - channel 2 (@1,4) - channels 1 and 4 (@1:3) - channels 1 through 3.	Required parameter

For example, to enable bit 3 (decimal value = 8) and bit 5 (decimal value = 32), the corresponding decimal value would be 40 (8 + 32).

Remarks

The following table lists the bit definitions for the Questionable Status registers.

Bit Number	Decimal Value	Definition
0 OV	1	The output is disabled by the over-voltage protection.
1 OC	2	The output is disabled by the over-current protection.
2 PF	4	The output is disabled by the power-fail - which may be caused by a low-line or brownout condition on the AC line.
3 CP+	8	The output is limited (or disabled) by the positive power limit.
4 OT	16	The over-temperature protection has tripped.

Bit Number		Decimal Value	Definition
5	CP-	32	The output is limited by the negative power limit.
6	OV-	64	The negative over-voltage protection has tripped.
7	LIM+	128	The output is in positive voltage or current limit.
8	LIM-	256	The output is in negative voltage or current limit.
9	INH	512	The output is inhibited by an external signal.
10	UNR	1024	The output is unregulated.
11	PROT	2048	The output has been disabled because it is coupled to a protection condition that occurred on another channel.
12	OSC	4096	The oscillation detector has tripped.
13-15	Not Used	Not Used	0 is returned.

If the same bits in both NTR and PTR registers are set to 1, then any transition of that bit at the Questionable Condition register sets the corresponding bit in the Questionable Event register.

If the same bits in both NTR and PTR registers are set to 0, then no transition of that bit at the Questionable Condition register can set the corresponding bit in the Questionable Event register.

The [STATus:PRESet](#) command will set all bits in the NTR register to 0.

Return Format

<NR1>

The value returned is the binary-weighted sum of all bits set in the register.

Examples

The following command enables bits 0 and 1 (decimal value = 3) in the NTR register.

```
STAT:QUES:NTR 3, (@1)
```

The following query returns which bits are enabled in the register.

```
STAT:QUES:NTR? (@1)
```

Typical Response: +3

See Also

[STATus:QUEStionable:PTRansition](#)

[STATus:PRESet](#)

STATus:QUEStionable:PTRansition

Syntax

```
STATus:QUEStionable:PTRansition <value>,
(@<chanlist>)
```

```
STATus:QUEStionable:PTRansition? (@<chanlist>)
```

Description

These command sets and reads the value of the Questionable PTR (Positive-Transition) register. This register serves as a polarity filter between the Questionable Condition and Questionable Event registers.

When a bit in the Questionable PTR register is set to 1, then a 0-to-1 transition of the corresponding bit in the Questionable Condition register causes that bit in the Questionable Event register to be set.

NOTE

For more information on the SCPI Status System, see the [Status System diagram](#)

Parameters

Name	Type	Range of Values	Default Value
<value>	NR1	A decimal value which corresponds to the binary-weighted sum of the bits in the register (see table below).	Preset = 8191
<chanlist>	Numeric	One or more channels. (@2) - channel 2 (@1,4) - channels 1 and 4 (@1:3) - channels 1 through 3.	Required parameter

For example, to enable bit 3 (decimal value = 8) and bit 5 (decimal value = 32), the corresponding decimal value would be 40 (8 + 32).

Remarks

The following table lists the bit definitions for the Questionable Status registers.

Bit Number	Decimal Value	Definition
0 OV	1	The output is disabled by the over-voltage protection.
1 OC	2	The output is disabled by the over-current protection.
2 PF	4	The output is disabled by the power-fail - which may be caused by a low-line or brownout condition on the AC line.
3 CP+	8	The output is limited (or disabled) by the positive power limit.
4 OT	16	The over-temperature protection has tripped.

Bit Number		Decimal Value	Definition
5	CP-	32	The output is limited by the negative power limit.
6	OV-	64	The negative over-voltage protection has tripped.
7	LIM+	128	The output is in positive voltage or current limit.
8	LIM-	256	The output is in negative voltage or current limit.
9	INH	512	The output is inhibited by an external signal.
10	UNR	1024	The output is unregulated.
11	PROT	2048	The output has been disabled because it is coupled to a protection condition that occurred on another channel.
12	OSC	4096	The oscillation detector has tripped.
13-15	Not Used	Not Used	0 is returned.

If the same bits in both NTR and PTR registers are set to 1, then any transition of that bit at the Questionable Condition register sets the corresponding bit in the Questionable Event register.

If the same bits in both NTR and PTR registers are set to 0, then no transition of that bit at the Questionable Condition register can set the corresponding bit in the Questionable Event register.

The [STATus:PRESet](#) command will set all bits in the PTR register to 1.

Return Format

<NR1>

The value returned is the binary-weighted sum of all bits set in the register.

Examples

The following command enables bits 0 and 1 (decimal value = 3) in the PTR register.

```
STAT:QUES:PTR 3, (@1)
```

The following query returns which bits are enabled in the register.

```
STAT:QUES:PTR? (@1)
```

Typical Response: +3

See Also

[STATus:QUEStionable:NTRansition](#)

[STATus:PRESet](#)

SYSTEM Commands Introduction

System commands control system functions that are not directly related to output control, measurement, or status functions.

Common commands also control system functions such as self-test, saving and recalling states, and others.

SCPI Command	Description
SYSTem	
:CHANnel	
[:COUNT]?	Returns the number of output channels in a mainframe
:MODEl? (@chanlist)	Returns the model number of the selected channel
:OPTion? (@chanlist)	Returns the option installed in the selected channel
:SERial? (@chanlist)	Returns the serial number of the selected channel
:COMMunicate	
:RLState LOCAL REMote RWLock	Specifies the Remote/Local state of the instrument
:TCPip	
:CONTRol?	Returns the control connection port number
:ERRor?	Returns the error number and error string
:GROup	(Group commands do NOT apply to N678xA SMU)
:CATalog?	Returns the groups that have been defined
:DEFine (@chanlist)	Group multiple channels to create a single output
:DELete <channel>	Removes the specified channel from a group
:ALL	Ungroups all channels
:PASSword	
:FPANel	
:RESet	Resets the front panel lock password to zero
:REBoot	Returns the unit to its power-on state
:VERSion?	Returns the SCPI version number

SYSTem:CHANnel[:COUNT]?

Syntax

```
SYSTem:CHANnel[:COUNT]?
```

Description

This query returns the number of output channels in a mainframe.

Return Format

<NR1>

The number of output channels.

Example

The following query returns the number of channels.

```
SYST:CHAN?
```

Typical Response: +4

SYSTem:CHANnel:MODEl?**Syntax**

SYSTem:CHANnel:MODEl? (@<chanlist>)

Description

This query returns the model numbers of the specified output channels.

Parameters

Name	Type	Range of Values	Default Value
<chanlist>	Numeric	One or more channels. (@2) - channel 2 (@1,4) - channels 1 and 4 (@1:3) - channels 1 through 3.	Required parameter

Return Format

<AARD>

The model number of the output channel. Multiple responses are separated by commas.

Example

The following query returns the model number in channels 2 and 3.

```
SYST:CHAN:MOD? (@2,3)
```

Typical Response: N6751A,N6761A

SYSTem:CHANnel:OPTion?

Syntax

SYSTem:CHANnel:OPTion? (@<chanlist>)

Description

This query returns a list of options installed in each channel specified in the channel list.

Parameters

Name	Type	Range of Values	Default Value
<chanlist>	Numeric	One or more channels. (@2) - channel 2 (@1,4) - channels 1 and 4 (@1:3) - channels 1 through 3.	Required parameter

Return Format

<SRD>

The query command returns an ASCII string enclosed in double quotes. If no option is installed, an empty quoted string ("") is returned. Multiple responses are separated by commas.

Example

The following query returns the options in channels 1 through 3.

```
SYST:CHAN:OPT? (@1:3)
```

Response with options installed in channels 1 and 2, none in channel 3:

```
"Opt 760","Opt 760", ""
```

SYSTem:CHANnel:SERial?**Syntax**

SYSTem:CHANnel:SERial? (@<chanlist>)

Description

This query returns the serial number of the specified output channels.

Parameters

Name	Type	Range of Values	Default Value
<chanlist>	Numeric	One or more channels. (@2) - channel 2 (@1,4) - channels 1 and 4 (@1:3) - channels 1 through 3.	Required parameter

Return Format

<AARD>

The serial number of the output channel. Multiple responses are separated by semicolons.

Example

The following query returns the serial numbers in channels 2 and 3.

```
SYST:CHAN:SER? (@2,3)
```

Typical Response: MY00123456;MY00234567

SYSTem:COMMunicate:RLState

Syntax

```
SYSTem:COMMunicate:RLState <state>
```

```
SYSTem:COMMunicate:RLState?
```

Description

This command configures the remote/local state of the instrument according to the following settings:

LOCal	The instrument is set to front panel and remote interface control.
REMOte	The instrument is set to front panel and remote interface control.
RWLock	The front panel keys are disabled. The instrument can only be controlled via the remote interface. This programmable setting is completely independent from the front panel lock/unlock function that is available from the front panel menu.

NOTE

The remote/local state is unaffected by *RST or any SCPI commands other than SYSTem:COMMunicate:RLState.

Parameters

Name	Type	Range of Values	Default Value
<state>	CPD	LOCAl REMote RWLock	LOCAl (set at power-on)

Remarks

The remote/local instrument state can also be set by other interface commands over the GPIB and some other I/O interfaces.

When multiple remote programming interfaces are active, the interface with the most recently changed remote/local state determines the instrument's remote/local state.

Return Format

```
<CRD>
```

The query command returns LOC, REM, or RWL.

Examples

The following command sets the remote/local state of the instrument.

```
SYST:COMM:RLST REMote
```

The following query returns the remote/local state of the instrument.

```
SYST:COMM:RLST?
```

Typical Response: LOC

SYSTem:COMMunicate:TCPip:CONTRol?

Syntax

SYSTem:COMMunicate:TCPip:CONTRol?

Description

This query returns the control connection port number. This is used to open a control socket connection to the instrument. Unlike the data socket, which uses a fixed port number (5025 for Agilent instruments), the port number for a control socket varies, and must be obtained using this query.

NOTE

Refer to chapter 3 of the User's Guide under "Using Sockets" for more information.

Remarks

After the control port number is obtained, a control socket connection can be opened.

The control socket connection can only be used by a client to send a [Device Clear](#) to the instrument or to detect Service Request (SRQ) events.

All commands to the control socket must be terminated with a newline <NL>, and all query responses returned on the control socket will be terminated with a newline.

Return Format

<NR1>

The Control connection port number.

Example

The following query returns the Control connection port number.

```
SYST:COMM:TCP:CONT?
```

Typical Response: +5000

SYSTem:ERRor?

Syntax

SYSTem:ERRor?

Description

This query returns the next error number and its corresponding message string from the error queue.

For a complete listing of instrument and system error messages, see [SCPI Error Messages](#).

Remarks

The front-panel **ERR** annunciator turns on when one or more errors are currently stored in the error queue.

Errors are retrieved in first-in-first-out (FIFO) order. The first error returned is the first error that was stored.

Errors are cleared as you read them. When you have read all errors from the error queue, the **ERR** annunciator turns off and the errors are cleared.

If more errors have accumulated than the queue can hold, the last error stored in the queue (the most recent error) is replaced with -350, "Error queue overflow". No additional errors are stored until you remove errors from the queue. If no errors have occurred when you read the error queue, the instrument responds with +0, "No error".

The error queue is cleared by the [*CLS](#) (Clear Status) command and when power is cycled. The errors are also cleared when you read the error queue.

Return Format

<NR1>,<SRD>

The error string may contain up to 80 characters and consists of an error number and an error string enclosed in double quotes. For example: -113,"Undefined header".

Example

The following query reads and clears one error.

```
SYST:ERR?
```

Typical Response: -101,"Invalid character"

SYSTem:GROup:CATalog?

Syntax

SYSTem:GROup:CATalog?

Description

This query returns information about channels that are grouped. The defined groups are enclosed in quotes.

NOTE

This command does NOT apply to models N678xA SMU.

Return Format

<SRD>

The defined groups in quotes. Multiple responses are separated by commas.

Example

The following query returns the channels that are grouped.

```
SYST:GRO:CAT?
```

Response with 4 channels; none grouped: "1", "2", "3", "4"

Response with channels 1 + 2 grouped; 3 + 4 grouped: "1,2", "3,4"

Response with channels 1 - 3 grouped; channel 4 not grouped:
"1,2,3", "4"

SYSTem:GROup:DEFine

Syntax

SYSTem:GROup:DEFine (@<chanlist>)

Description

This command defines a list of output channels as a paralleled group. This effectively creates a single output with higher current and power capability. You can group up to four channels per mainframe.

All channels in a group must have identical model numbers and have identical options installed.

All grouped channels must have their output terminals and, if remote sensing, their sense terminals connected in parallel.

After the channels are wired in parallel and defined as a group, they can be addressed using any of the channel-specific SCPI commands by sending the channel number of the **LOWEST** channel in the group.

NOTE

This command does NOT apply to models N678xA SMU.

Parameters

Name	Type	Range of Values	Default Value
<chanlist>	Numeric	Two or more channels. (@1,2) - channels 1 and 2 (@1:3) - channels 1 through 3.	Required parameter

Remarks

For the group changes to take effect, you must reboot the unit. Either cycle AC power or send the [SYSTem:REBoot](#) command.

Group channel definitions are stored in non-volatile memory and are unaffected by [*RST](#) or [*RCL](#).

Group channel *settings* (voltage, current, etc.) are set and saved by [*RST](#) or [*RCL](#).

This command also deletes any previously saved states.

Example

The following command defines channels 1, 2, and 3 as a group.

```
SYST:GRO:DEF (@1:3)
```

The following command defines channels 1 and 4 as a group.

```
SYST:GRO:DEF (@1,4)
```

SYSTem:GROup:DELeTe**Syntax**

```
SYSTem:GROup:DELeTe <channel>
```

Description

This command removes the indicated channel from a group. It leaves the other channels in the group intact.

When ungrouping a channel, you must also remove the parallel connections between the output and sense terminals of that channel.

NOTE

This command does NOT apply to models N678xA SMU.

Parameters

Name	Type	Range of Values	Default Value
<channel>	NR1	1 2 3 4	Required parameter

Remarks

For the group changes to take effect, you must reboot the unit. Either cycle AC power or send the [SYSTem:REBoot](#) command.

This command also deletes any previously saved states.

Example

The following command deletes channel 3 from a group.

```
SYST:GRO:DEL 3
```

SYSTem:GROup:DELeTe:ALL

Syntax

```
SYSTem:GROup:DELeTe:ALL
```

Description

This command deletes all groups on a mainframe. It returns any channels that have been grouped back to an ungrouped state.

When ungrouping channels, you must also remove all paralleled sense and output terminal connections between channels.

NOTE

This command does NOT apply to models N678xA SMU.

Remarks

For the group changes to take effect, you must reboot the unit. Either cycle AC power or send the [SYSTem:REBoot](#) command.

This command also deletes any previously saved states.

Example

The following command deletes all groups.

```
SYST:GRO:DEL:ALL
```

SYSTem:PASSword:FPANel:RESet

Syntax

```
SYSTem:PASSword:FPANel:RESet
```

Description

This command resets the front panel lockout password to the factory-shipped setting, which is zero (0). This command does not reset the calibration password.

NOTE

The front panel password can also be reset to 0 by setting an internal switch on the unit. Refer to the Service Manual under “Calibration Switches” for more information.

Example

The following command resets the front panel password.

```
SYST:PASS:FPAN:RES
```

See Also

[*RST](#)

SYSTem:REBoot

Syntax

SYSTem:REBoot

Description

This command causes the instrument to reboot to its power-on state.

Example

The following command reboots the instrument.

```
SYST:REB
```

See Also

[*RST](#)

SYSTem:VERSion?

Syntax

SYSTem:VERSion?

Description

This command returns the version of the SCPI (Standard Commands for Programmable Instruments) standard with which the instrument is in compliance.

Return Format

<SRD>

The command returns a string in the form "YYYY.V", where YYYY represents the year of the version and V represents a version for that year.

Example

The following query returns the SCPI version.

```
SYST:VERS?
```

Typical Response: "1997.0"

TRIGger Subsystem Introduction

Trigger commands control the remote triggering of the instrument. They specify the trigger source for the transient and the measurement system and also generate software triggers.

The Common command [*TRG](#) is also used to trigger the instrument.

SCPI Command	Description
TRIGger	
:ACQuire	(Acquire commands only on N676xA, N678xA SMU and Option 054)
[:IMMediate] (@chanlist)	Triggers the measurement immediately
:CURRent	
[:LEVel] <NRf>, (@chanlist)	Sets the current trigger level
:SLOPe POSitive NEGative, (@chanlist)	Sets the current trigger slope
:SOURce BUS CURRent<1-4> EXTernal PIN<1-7> TRANsient<1-4> VOLTage<1-4>, (@chanlist)	Sets the measurement trigger source
:TOUtput	
[:ENABle] <Bool>, (@chanlist)	Enables measurement triggers to be sent to a digital port pin
:VOLTage	
[:LEVel] <NRf>, (@chanlist)	Sets the voltage trigger level
:SLOPe POSitive NEGative, (@chanlist)	Sets the voltage trigger slope
:ELOG	
[:IMMediate] (@chanlist)	Triggers the external data logger immediately
:SOURce BUS EXTernal IMMediate PIN<n>, (@chanlist)	Sets the external data logger trigger source
:TRANsient	
[:IMMediate] (@chanlist)	Triggers the output immediately
:SOURce BUS EXTernal IMMediate PIN<1-7> TRANsient<1-4>, (@chanlist)	Sets the output trigger source

TRIGger:ACQuire[:IMMediate]**Syntax**

```
TRIGger:ACQuire[:IMMediate] (@<chanlist>)
```

Description

This command sends an immediate trigger to the measurement system. When the trigger system is initiated, a measurement trigger causes the instrument to measure the output voltage or current, and store the results in a buffer.

NOTE

This command is used only with models N676xA, N678xA SMU, or models that have Option 054 (High Speed Test Extensions).

Parameters

Name	Type	Range of Values	Default Value
<chanlist>	Numeric	One or more channels. (@2) - channel 2 (@1,4) - channels 1 and 4 (@1:3) - channels 1 through 3.	Required parameter

Remarks

You must initiate the measurement trigger system before you can send any triggers.

The measured quantity, either voltage or current, must be specified by the SENSE:FUNCTION command.

When the triggered measurement has completed, the WTG-meas bit in the Status Operation Condition register is cleared.

Example

The following command generates a measurement trigger on channels 1 and 2.

```
TRIG:ACQ (@1,2)
```

See Also

[INITiate\[:IMMediate\]:ACQuire](#)

[SENSe:FUNCTion](#)

[*TRG](#)

TRIGger:ACQuire:CURRent[:LEVel]**Syntax**

```
TRIGger:ACQuire:CURRent[:LEVel] <current>,
(@<chanlist>)
```

```
TRIGger:ACQuire:CURRent[:LEVel]? [MIN|MAX, ]
(@<chanlist>)
```

Description

This command sets the triggered current level of the specified output channel when the measurement trigger source is set to current. Units are in amperes.

NOTE

This command is used only with models N676xA, N678xA SMU, or models that have Option 054 (High Speed Test Extensions).

Parameters

Name	Type	Range of Values	Default Value
<current>	NRf+	0 - maximum MIN MAX The maximum value is dependent on the current rating of the power module.	MIN
<chanlist>	Numeric	One or more channels. (@2) - channel 2 (@1,4) - channels 1 and 4 (@1:3) - channels 1 through 3.	Required parameter

Remarks

The output channel specified with this command must match the output channel specified by [TRIGger:ACQuire:SOURce](#).

A non-programmable hysteresis for level triggers reduces false triggering on slow signals. The hysteresis is set to 0.0005 X maximum range value. For example, on the 10 A range, the hysteresis is approximately 5 mA.

Return Format

```
<NR3>
```

The query command returns the programmed trigger level in the form +n.nnnnnnE+nn for the specified output channel.

Examples

The following command sets the triggered current level to 2 A on channel 2.

```
TRIG:ACQ:CURR 2, (@2)
```

The following query returns the programmed triggered current level.

```
TRIG:ACQ:CURR (@2)
```

Typical Response: +2.000000E+00

See Also

[TRIGger:ACQuire:SOURce](#)

TRIGger:ACQuire:CURRent:SLOPe

Syntax

```
TRIGger:ACQuire:CURRent:SLOPe <slope>, (@<chanlist>)
```

```
TRIGger:ACQuire:CURRent:SLOPe? (@<chanlist>)
```

Description

This command sets the slope of the current signal of the specified output channel when the trigger source for the measurement is set to a current level.

POSitive Specifies a rising slope of the output signal.

NEGative Specifies a falling slope of the output signal.

NOTE

This command is used only with models N676xA, N678xA SMU, or models that have Option 054 (High Speed Test Extensions).

Parameters

Name	Type	Range of Values	Default Value
<slope>	CPD	POSitive NEGative	POS
<chanlist>	Numeric	One or more channels. (@2) - channel 2 (@1,4) - channels 1 and 4 (@1:3) - channels 1 through 3.	Required parameter

Remarks

The output channel specified with this command must match the output channel specified by [TRIGger:ACQuire:SOURce](#).

Return Format

```
<CRD>
```

The query command returns POS or NEG.

Examples

The following command sets the current slope to Positive on output channel 2.

```
TRIG:ACQ:CURR:SLOP POS, (@2)
```

The following query returns the current slope on output channel 2.

```
TRIG:ACQ:CURR:SLOP (@2)
```

Typical Response: POS

See Also

[TRIGger:ACQuire:SOURce](#)

TRIGger:ACQuire:SOURce

Syntax

```
TRIGger:ACQuire:SOURce <source>, (@<chanlist>)
```

```
TRIGger:ACQuire:SOURce? (@<chanlist>)
```

Description

This command selects the trigger source for the measurement trigger system. The following trigger sources can be selected:

BUS	Selects a remote interface trigger command.
CURRent<n>	Selects an output current level. <n> specifies the channel.
EXtErnal	Selects ALL connector pins that have been configured as trigger sources.
PIN<n>	Selects a digital port pin configured as a trigger input. <n> specifies the pin number.
TRANsient<n>	Selects the transient system of an output channel as the trigger source. <n> specifies the channel.
VOLTage<n>	Selects an output voltage level. <n> specifies the channel.

NOTE

This command is used only with models N676xA, N678xA SMU, or models that have Option 054 (High Speed Test Extensions).

Parameters

Name	Type	Range of Values	Default Value
<source>	CPD	BUS CURRent<1-4> PIN<1-7> TRANsient<1-4> VOLTage<1-4>	BUS
<chanlist>	Numeric	One or more channels. (@2) - channel 2 (@1,4) - channels 1 and 4 (@1:3) - channels 1 through 3.	Required parameter

Remarks

PIN<n> must be configured as trigger input before it can be used as a trigger source. See [\[SOURce:\]:DIGital:PIN<n>:FUNCTION](#) and [\[SOURce:\]:DIGital:PIN<n>:POLarity](#).

You can also configure the transient system to use it as a trigger source. See: [\[SOURce:\]:STEP:TOUTput](#), [\[SOURce:\]:LIST:TOUTput:BOSTep](#), and [\[SOURce:\]:LIST:TOUTput:EOSTep](#).

When specifying an output current or voltage level, you must also specify the level as well as the slope. See:

[TRIGger:ACQuire:CURRent\[:LEVel\]](#),
[TRIGger:ACQuire:CURRent:SLOPe](#),
[TRIGger:ACQuire:VOLTagE\[:LEVel\]](#), and
[TRIGger:ACQuire:VOLTagE:SLOPe](#).

Return Format

<CRD>

The query command returns BUS, CURR<n>, PIN<n>, TRAN<n>, or VOLT<n>.

Examples

The following command selects pin 1 as the measurement trigger source for channel 2.

```
TRIG:ACQ:SOUR PIN1,(@2)
```

The following query returns the measurement trigger source of channel 1.

```
TRIG:ACQ:SOUR? (@1)
```

Typical Response: BUS

See Also

[\[SOURce:\]DIGital:PIN<1-7>:FUNction](#)

[\[SOURce:\]DIGital:PIN<1-7>:POLarity](#)

[\[SOURce:\]STEP:TOUTput](#)

[\[SOURce:\]LIST:TOUTput:BOSTep](#)

[\[SOURce:\]LIST:TOUTput:EOSTep](#)

TRIGger:ACQuire:TOUTput[:ENABle]**Syntax**

```
TRIGger:ACQuire:TOUTput[:ENABle] <Bool>,
(@<chanlist>)
```

```
TRIGger:ACQuire:TOUTput[:ENABle]? (@<chanlist>)
```

Description

This command enables measurement triggers to be sent to any digital port pin that has been configured as a trigger output. The enabled state is ON (1); the disabled state is OFF (0).

When a measurement is initiated, the MEAS_active status bit is set true, allowing measurement triggers to be sent. Measurement triggers can continue to be sent until the measurement completes or is aborted and the MEAS_active status is set false.

NOTE

This command is used only with models N676xA, N678xA SMU, or models that have Option 054 (High Speed Test Extensions).

Parameters

Name	Type	Range of Values	Default Value
<Bool>	Boolean	OFF 0 ON 1	OFF
<chanlist>	Numeric	One or more channels. (@2) - channel 2 (@1,4) - channels 1 and 4 (@1:3) - channels 1 through 3.	Required parameter

Remarks

The digital port pin must be configured as a trigger output before it can source a trigger signal. See [\[SOURCE:|DIGital:PIN<n>:FUNCTION](#) and [\[SOURCE:|DIGital:PIN<n>:POLarity](#).

When the measurement trigger source is a transient trigger or output voltage/current level, ANY measurement trigger that occurs is sent to the configured trigger output pin. You must make sure that no trigger occurs other than the trigger of interest. TRIGger:ACQuire:TOUTput is disabled when the acquisition is complete.

If the measurement trigger source generates multiple trigger events, each trigger event will generate a measurement trigger signal at the configured trigger output pins. In this case, it may not be possible to identify which trigger event was the one that actually triggered the measurement.

Return Format

```
<NR1>
```

The query command returns 0 if the command is disabled, and 1 if the command is enabled.

Examples

The following command enables sending measurement triggers to digital output pins on channel 2.

```
TRIG:ACQ:TOUT ON, (@2)
```

The following query returns the state of TRIG:ACQ:TOUT on output channel 2.

```
TRIG:ACQ:TOUT? (@2)
```

Typical Response: 1

See Also

[TRIGger:ACQuire:SOURce](#)

TRIGger:ACQuire:VOLTage[:LEVel]

Syntax

```
TRIGger:ACQuire:VOLTage[:LEVel] <voltage>,
(@<chanlist>)
```

```
TRIGger:ACQuire:VOLTage[:LEVel]? [MIN|MAX, ]
(@<chanlist>)
```

Description

This command sets the triggered voltage level of the specified output channel when the measurement trigger source is set to voltage. Units are in volts.

NOTE

This command is used only with models N676xA, N678xA SMU, or models that have Option 054 (High Speed Test Extensions).

Parameters

Name	Type	Range of Values	Default Value
<voltage>	NRf+	0 - maximum MIN MAX The maximum value is dependent on the voltage rating of the power module.	MIN
<chanlist>	Numeric	One or more channels. (@2) - channel 2 (@1,4) - channels 1 and 4 (@1:3) - channels 1 through 3.	Required parameter

Remarks

The output channel specified with this command must match the output channel specified by [TRIGger:ACQuire:SOURce](#).

A non-programmable hysteresis for level triggers reduces false triggering on slow signals. The hysteresis is set to 0.0005 X maximum range value. For example, on the 50 V range, the hysteresis is approximately 25 mV

Return Format

```
<NR3>
```

The query command returns the programmed trigger level in the form +n.nnnnnnE+nn for the specified output channel.

Examples

The following command sets the triggered voltage level to 5 V on channel 2.

3 Commands by Subsystem

```
TRIG:ACQ:VOLT 5, (@2)
```

The following query returns the programmed triggered voltage level.

```
TRIG:ACQ:VOLT (@2)
```

Typical Response: +5.000000E+00

See Also

[TRIGger:ACQuire:SOURce](#)

TRIGger:ACQuire:VOLTage:SLOPe

Syntax

```
TRIGger:ACQuire:VOLTage:SLOPe <slope>, (@<chanlist>)
```

```
TRIGger:ACQuire:VOLTage:SLOPe? (@<chanlist>)
```

Description

This command sets the slope of the voltage signal of the specified output channel when the trigger source for the measurement is set to a voltage level.

POSitive Specifies a rising slope of the output signal.

NEGative Specifies a falling slope of the output signal.

NOTE

This command is used only with models N676xA, N678xA SMU, or models that have Option 054 (High Speed Test Extensions).

Parameters

Name	Type	Range of Values	Default Value
<slope>	CPD	POSitive NEGative	POS
<chanlist>	Numeric	One or more channels. (@2) - channel 2 (@1,4) - channels 1 and 4 (@1:3) - channels 1 through 3.	Required parameter

Remarks

The output channel specified with this command must match the output channel specified by [TRIGger:ACQuire:SOURce](#).

Return Format

```
<CRD>
```

The query command returns POS or NEG.

Examples

The following command sets the voltage slope to Positive on output channel 2.

```
TRIG:ACQ:VOLT:SLOP POS, (@2)
```

The following query returns the voltage slope on output channel 2.

```
TRIG:ACQ:VOLT:SLOP? (@2)
```

Typical Response: POS

See Also

[TRIGger:ACQuire:SOURce](#)

TRIGger:ELOG[:IMMediate]**Syntax**

```
TRIGger:ELOG[:IMMediate] (@<chanlist>)
```

Description

This command sends an immediate trigger signal to the external data logger. This will trigger the external data log regardless of the selected trigger source.

Parameters

Name	Type	Range of Values	Default Value
<chanlist>	Numeric	One or more channels. (@2) - channel 2 (@1,4) - channels 1 and 4 (@1:3) - channels 1 through 3.	Required parameter

Remarks

You must initiate (run) the external data logger before you trigger it.

Example

The following command triggers the external data logger on channel 1.

```
TRIG:ELOG @1
```

See Also

[INITiate\[:IMMediate\]:ELOG](#)

[SENSe:ELOG:FUNction:CURRent](#)

[SENSe:ELOG:FUNction:VOLTage](#)

[*TRG](#)

TRIGger:ELOG:SOURce

Syntax

```
TRIGger:ELOG:SOURce <source>, (@<chanlist>)
```

```
TRIGger:ELOG:SOURce? (@<chanlist>)
```

Description

This command selects the trigger source for the external data logger. The following trigger sources can be selected:

BUS	Selects a remote interface trigger command.
EXTernal	Selects ALL connector pins that have been configured as trigger sources.
IMMediate	Sets the trigger source true, so that as soon as the external data logger is INITiated it will send the trigger immediately.
PIN<n>	Selects a digital port pin configured as a trigger input. <n> specifies the pin number.

Parameters

Name	Type	Range of Values	Default Value
<source>	CPD	BUS EXTernal IMMediate PIN<1-7>	BUS
<chanlist>	Numeric	One or more channels. (@2) - channel 2 (@1,4) - channels 1 and 4 (@1:3) - channels 1 through 3.	Required parameter

Remarks

PIN<n> must be configured as trigger input before it can be used as a trigger source. See [\[SOURce:JDIGital:PIN<n>:FUNCTION\]](#) and [\[SOURce:JDIGital:PIN<n>:POLarity\]](#).

Return Format

```
<CRD>
```

The query command returns IMM, EXT, BUS, or PIN<n>.

Examples

The following command selects BUS as the external data log trigger source.

```
TRIG:ELOG:SOUR BUS,@1
```

The following query returns the data log trigger source.

```
TRIG:ELOG:SOUR? @1
```

Typical Response: BUS

TRIGger:TRANSient[:IMMediate]**Syntax**

```
TRIGger:TRANSient[:IMMediate] (@<chanlist>)
```

Description

This command generates an immediate transient trigger regardless of the selected trigger source. Output triggers affect the following functions: voltage, current, and current limit.

Parameters

Name	Type	Range of Values	Default Value
<chanlist>	Numeric	One or more channels. (@2) - channel 2 (@1,4) - channels 1 and 4 (@1:3) - channels 1 through 3.	Required parameter

Remarks

You must initiate the output trigger system before you can send any triggers.

When sent, the transient trigger will initiate an output change as specified by the CURRent:TRIGgered or VOLTage:TRIGgered commands.

When the transient trigger sequence has completed, the WTG-tran bit in the Status Operation Condition register is cleared.

Example

The following command generates an output trigger on channels 1 and 2.

```
TRIG:TRAN (@1,2)
```

See Also

[INITiate\[:IMMediate\]:TRANSient](#)

[\[SOURce\]:\[CURRent\[:LEVel\]:TRIGgered](#)

[\[SOURce\]:\[VOLTage\[:LEVel\]:TRIGgered](#)

[*TRG](#)

TRIGger:TRANSient:SOURce

Syntax

```
TRIGger:TRANSient:SOURce <source>, (@<chanlist>)
```

```
TRIGger:TRANSient:SOURce? (@<chanlist>)
```

Description

This command selects the trigger source for the output trigger system. The following trigger sources can be selected:

BUS	Selects a remote interface trigger command.
EXTernal	Selects ALL connector pins that have been configured as trigger sources.
IMMediate	Sets the trigger source true, so that as soon as the data logger is INITiated it will send the trigger immediately.
PIN<n>	Selects a digital port pin configured as a trigger input. <n> specifies the pin number.
TRANSient<n>	Selects the transient system of an output channel as the trigger source. <n> specifies the channel.

Parameters

Name	Type	Range of Values	Default Value
<source>	CPD	BUS EXTernal IMMediate PIN<1-7> TRANSient<1-4>	BUS
<chanlist>	Numeric	One or more channels. (@2) - channel 2 (@1,4) - channels 1 and 4 (@1:3) - channels 1 through 3.	Required parameter

Remarks

PIN<n> must be configured as trigger input before it can be used as a trigger source. See [\[SOURCE:|DIGital:PIN<n>:FUNCTION\]](#) and [\[SOURCE:|DIGital:PIN<n>:POLarity\]](#).

You can also configure the transient system to use it as a trigger source. See: [\[SOURCE:|STEP:TOUTput\]](#), [\[SOURCE:|LIST:TOUTput:BOStep\]](#), and [\[SOURCE:|LIST:TOUTput:EOStep\]](#).

Return Format

```
<CRD>
```

The query command returns BUS, PIN<n>, or TRAN<n>.

Examples

The following command selects pin 1 as the output trigger source for channel 2.

```
TRIG:TRAN:SOUR PIN1, (@2)
```

The following query returns the output trigger source of channel 1.

```
TRIG:TRAN:SOUR? (@1)
```

Typical Response: BUS

See Also

[\[SOURCE:|DIGital:PIN<1-7>:FUNCTION](#)

[\[SOURCE:|DIGital:PIN<1-7>:POLarity](#)

[\[SOURCE:|STEP:TOUTput](#)

[\[SOURCE:|LIST:TOUTput:BOSTep](#)

[\[SOURCE:|LIST:TOUTput:EOSTep](#)

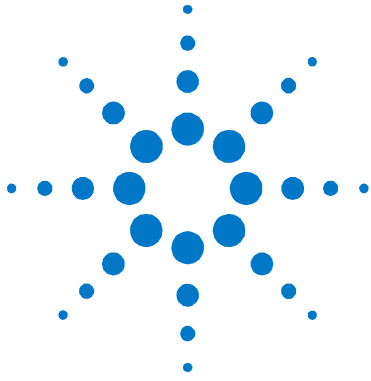

4

Command Quick Reference

SCPI Command Summary	322
Non-Volatile Settings	328
Reset Settings (*RST)	329

SCPI Command Summary

Subsystem Commands

NOTE

Some [optional] commands have been included for clarity. All settings commands have a corresponding query. Not all commands apply to all models.

SCPI Command	Description
ABORt	
:ACQuire (@chanlist)	Resets the measurement trigger system to the Idle state
:ELOG (@chanlist)	Stops the external data log
:TRANsient (@chanlist)	Resets the transient trigger system to the Idle state
CALibrate	
:CURRent	
[:LEVel] <NRf>, (@channel)	Calibrates the output current programming
:LIMit	
:NEGative <NRf>, (@channel)	Calibrates the negative current limit (only on N6783A)
:POSitive <NRf>, (@channel)	Calibrates the positive current limit (only on N678xA SMU)
:MEASure <NRf>, (@channel)	Calibrates the current measurement
:PEAK (@channel)	Calibrates the peak current limit (only on N675xA, N676xA)
:DATA <NRf>	Enters the calibration value
:DATE <"date">, (@channel)	Sets the calibration date
:DPRog (@channel)	Calibrates the current downprogrammer
:LEVel P1 P2 P3	Advances to the next calibration step
:PASSword <NRf>	Sets the numeric calibration password
:RESistance 20 6, (@channel)	Calibrates the output resistance (only on N6781A)
:SAVE	Saves the new cal constants in non-volatile memory
:STATE <Bool> [,<NRf>]	Enables/disables calibration mode
:VOLTage	
[:LEVel] <NRf>, (@channel)	Calibrates the output voltage programming
:CMRR (@channel)	Calibrates common mode rejection ratio (only N675xA, N676xA)
:LIMit	
:POSitive <NRf>, (@channel)	Calibrates the positive voltage limit (only on N678xA SMU)
:MEASure <NRf>, (@channel)	Calibrates the voltage measurement
:AUXiliary (@channel)	Calibrates the auxiliary voltage measurement (only on N6781A)
DISPlay	
[:WINDow]	
:CHANnel <channel>	Selects the channel in 1-channel meter view
:VIEW METER1 METER4	Selects 1-channel or 4-channel meter view
FETCh	(Fetch commands only on N676xA, N678xA SMU and Option 054)
[:SCALar]	
:CURRent	
[:DC]? (@chanlist)	Returns the average current
:ACDC? (@chanlist)	Returns the total rms current (AC + DC)
:HIGH? (@chanlist)	Returns the high level of a current pulse
:LOW? (@chanlist)	Returns the low level of a current pulse
:MAXimum? (@chanlist)	Returns the maximum current
:MINimum? (@chanlist)	Returns the minimum current

SCPI Command	Description
FETCh[:SCALar] (continued)	
:POWer	
[:DC]? (@chanlist)	Returns the average output power
:VOLTage	
[:DC]? (@chanlist)	Returns the average voltage
:ACDC? (@chanlist)	Returns the total rms voltage (AC + DC)
:HIGH? (@chanlist)	Returns the high level of a voltage pulse
:LOW? (@chanlist)	Returns the low level of a voltage pulse
:MAXimum? (@chanlist)	Returns the maximum voltage
:MINimum? (@chanlist)	Returns the minimum voltage
:ARRay	
:CURRent [:DC]? (@chanlist)	Returns the instantaneous output current
:POWer [:DC]? (@chanlist)	Returns the instantaneous output power
:VOLTage [:DC]? (@chanlist)	Returns the instantaneous output voltage
:ELOG <NR1>, (@chanlist)	Returns the most recent external data log records
FORMat	
[:DATA] ASCII REAL	Returns data as ASCII or binary
:BORDER NORMal SWAPped	Sets the byte order of the external data log data
INITiate	
[:IMMEDIATE]	(Acquire command only on N676xA, N678xA SMU and Option 054)
:ACQuire (@chanlist)	Enables the measurement system to receive triggers
:ELOG (@chanlist)	Enables external data log measurements
:TRANsient (@chanlist)	Enables the output transient system to receive triggers
:CONTInuous	
:TRANsient <Bool>, (@chanlist)	Enables/disables continuous transient triggers
MEASure	
[:SCALar]	
:CURRent	
[:DC]? (@chanlist)	Takes a measurement; returns the average current
:ACDC? (@chanlist)	Takes a measurement; returns the total rms current (AC + DC)
:HIGH? (@chanlist)	Takes a measurement; returns the high level of a current pulse
:LOW? (@chanlist)	Takes a measurement; returns the low level of a current pulse
:MAXimum? (@chanlist)	Takes a measurement; returns the maximum current
:MINimum? (@chanlist)	Takes a measurement; returns the minimum current
:POWer	
[:DC]? (@chanlist)	Takes a measurement; returns the average output power
:VOLTage	
[:DC]? (@chanlist)	Takes a measurement; returns the average voltage
:ACDC? (@chanlist)	Takes a measurement; returns the total rms voltage (AC + DC)
:HIGH? (@chanlist)	Takes a measurement; returns the high level of a voltage pulse
:LOW? (@chanlist)	Takes a measurement; returns the low level of a voltage pulse
:MAXimum? (@chanlist)	Takes a measurement; returns the maximum voltage
:MINimum? (@chanlist)	Takes a measurement; returns the minimum voltage
:ARRay	(Array commands only on N676xA, N678xA SMU and Option 054)
:CURRent [:DC]? (@chanlist)	Takes a measurement; returns the instantaneous output current
:POWer [:DC]? (@chanlist)	Takes a measurement; returns the instantaneous output power
:VOLTage [:DC]? (@chanlist)	Takes a measurement; returns the instantaneous output voltage

4 Command Quick Reference

SCPI Command	Description
OUTPut	
[:STATe] <Bool> [,NORelay], (@chanlist)	Enables/disables the specified output channel(s)
:COUPle	
[:STATe] <Bool>	Enables/disables channel coupling for output synchronization
:CHANnel [<NR1> {,<NR1>}]	Selects which channels are coupled
:DOFFset <NRf>	Specifies a maximum delay offset to synchronize output changes
:MAX	
:DOFFset?	Returns the maximum delay offset required for a mainframe
:DELay	
:FALL <NRf+>, (@chanlist)	Sets the output turn-off sequence delay
:RISE <NRf+>, (@chanlist)	Sets the output turn-on sequence delay
:PMODE VOLTage CURRent, (@chanlist)	Sets the mode for turn on/off transitions (N6761A, N6762A)
:TMODE HIGHZ LOWZ, (@chanlist)	Specifies the turn-on/turn-off impedance (only on N678xA SMU)
:INHibit	
:MODE LATChing LIVE OFF	Sets the remote inhibit input
:PON	
:STATe RST RCL0	Programs the power-on state
:PROTection	
:CLEar (@chanlist)	Resets latched protection
:COUPle <Bool>	Enables/disables channel coupling for protection faults
:DELay <NRf+>, (@chanlist)	Sets over-current protection programming delay
:OSCillation <Bool>, (@chanlist)	Enables/disables output oscillation protection (N678xA SMU)
:WDOG	
[:STATe] <Bool>	Enables/disables the I/O watchdog timer
:DELay <NRf+>	Sets the watchdog timer delay
:RELay	
:POLarity NORMal REVerse, (@chanlist)	Sets the output relay polarity (Option 760)
SENSe	
:CURRent	
:CCOMpensate <Bool>, (@chanlist)	Enables/disables the capacitive current compensation
[:DC]:RANGe	
[:UPPer] <NRf+>, (@chanlist)	Selects the current measurement range
:AUTO <Bool>, (@chanlist)	Enables/disables measurement autoranging (N6781A N6782A)
:ELOG	
:CURRent	
[:DC]:RANGe	
[:UPPer] <NRf+>, (@chanlist)	Sets the external data log current range
:AUTO <Bool>, (@chanlist)	Enables/disables measurement autoranging (N6781A N6782A)
:FUNCTion	
:CURRent <Bool>, (@chanlist)	Enables/disables external current data logging
:MINMax <Bool>, (@chanlist)	Enables/disables external min/max current data logging
:VOLTage <Bool>, (@chanlist)	Enables/disables external voltage data logging
:MINMax <Bool>, (@chanlist)	Enables/disables external min/max voltage data logging
:PERiod <NR1>, (@chanlist)	Sets the integration time of the external data logging
:VOLTage	
[:DC]:RANGe	
[:UPPer] <NRf+>, (@chanlist)	Sets the external data log voltage range
:AUTO <Bool>, (@chanlist)	Enables/disables measurement autoranging (N6781A N6782A)
:FUNCTion "VOLTage" "CURRent" "NONE", (@chanlist)	Selects the measurement function (for backward compatibility)
:CURRent <Bool>, (@chanlist)	Enables/disables current measurements (replaces FUNCTion)
:VOLTage <Bool>, (@chanlist)	Enables/disables voltage measurements (replaces FUNCTion)
:INPut MAIN AUXiliary, (@chanlist)	Selects the voltage measurement input (only on N6781A)

SCPI Command	Description
SENSe (continued)	
:SWEep	(Sweep commands only on N676xA, N678xA SMU and Option 054)
:OFFSet	
:POINts <NRf+>, (@chanlist)	Defines the trigger offset in the measurement sweep
:POINts <NRf+>, (@chanlist)	Defines the number of data points in the measurement
:TINTerval <NRf+>, (@chanlist)	Sets the measurement sample interval
:RESolution RES20 RES40, (@chanlist)	Sets the measurement resolution
:VOLTage	
[:DC]:RANGe	
[:UPPer] <NRf+>, (@chanlist)	Selects the voltage measurement range
:AUTO <Bool>, (@chanlist)	Enables/disables measurement autoranging (N6781A N6782A)
:WINDow	
[:TYPE] HANNing RECTangular, (@chanlist)	Selects measurement window (N676xA, N678xA SMU, Option 054)
[SOURce:]	
CURRent	
[:LEVel]	
[:IMMEDIATE][:AMPLitude] <NRf+>, (@chanlist)	Sets the output current
:TRIGgered [:AMPLitude] <NRf+>, (@chanlist)	Sets the triggered output current
:LIMit	
[:POSitive]	
[:IMMEDIATE][:AMPLitude] <NRf+>, (@chanlist)	Sets the positive current limit (only on N678xA SMU, N6783A)
:COUPle <Bool>, (@chanlist)	Sets the current limit tracking state (only on N678xA SMU)
:NEGative	
[:IMMEDIATE][:AMPLitude] <NRf+>, (@chanlist)	Sets the negative current limit (only on N678xA SMU, N6783A-BAT)
:MODE FIXed STEP LIST, (@chanlist)	Sets the current trigger mode
:PROTection	
:DELay	
[:TIME] <NRf+>, (@chanlist)	Sets the over-current protection programming delay
:STARt SChange CCTRans, (@chanlist)	Sets the over-current protection programming mode
:STATe <Bool>, (@chanlist)	Enables/disables over-current protection on the selected output
:RANGe <NRf+>, (@chanlist)	Sets the output current range
:SLEW	
[:IMMEDIATE] <NRf+> INFInity, (@chanlist)	Sets the output current slew rate (only N678xA SMU)
:MAXimum <Bool>, (@chanlist)	Enables/disables the maximum slew rate override (N678xA SMU)
DIGital	
:INPut:DATA?	Reads the state of the digital port pins
:OUTPut:DATA <NRf>	Sets the digital port
:PIN<1-7>	
:FUNction DIO DINPut TOUTput TINPut FAULT INHibit ONCouple OFFCouple	Sets the selected pin's function
:POLarity POSitive NEGative	Sets the selected pin's polarity
:TOUTput	
:BUS[:ENABle] <Bool>	Enables/disables BUS-generated triggers on digital pins
FUNction CURRent VOLTage, (@chanlist)	Specifies current priority or voltage priority mode (N678xA SMU)
LIST	
:COUNt <NRf+> INFInity, (@chanlist)	(List commands only on N676xA, N678xA SMU and Option 054) Sets the list repeat count
:CURRent	
[:LEVel] <NRf> {,<NRf>}, (@chanlist)	Sets the current list
:POINts? (@chanlist)	Returns the number of current list points

4 Command Quick Reference

SCPI Command	Description
[SOURce:]LIST:TOUTput (continued)	
:DWELI <NRf> {,<NRf>}, (@chanlist)	Sets the list of dwell times
:POINTs? (@chanlist)	Returns the number of dwell list points
:STEP ONCE AUTO, (@chanlist)	Specifies how the list responds to triggers
:TERMinate	
:LAST <Bool>, (@chanlist)	Sets the list termination mode
:TOUTput	
:BOSTep	
[:DATA] <Bool> {,<Bool>}, (@chanlist)	Generate triggers at the Beginning Of Step
:POINTs? (@chanlist)	Returns the number of beginning of step list points
:EOSTep	
[:DATA] <Bool> {,<Bool>}, (@chanlist)	Generate triggers at the End Of Step
:POINTs? (@chanlist)	Returns the number of end of step list points
:VOLTage	
[:LEVel] <NRf> {,<NRf>}, (@chanlist)	Sets the voltage list
:POINTs? (@chanlist)	Returns the number of voltage level points
POWer	
:LIMit <NRf+>, (@chanlist)	Sets the power limit on output channels
RESistance	
[:LEVel][:IMMEDIATE][:AMPLitude] <NRf+>, (@chanlist)	Sets the output resistance (only on N6781A)
:STATe <Bool>, (@chanlist)	Enables/disables output resistance programming (only N6781A)
STEP	
:TOUTput <Bool>, (@chanlist)	Generate a trigger output on the voltage or current step transient
VOLTage	
[:LEVel]	
[:IMMEDIATE][:AMPLitude] <NRf+>, (@chanlist)	Sets the output voltage
:TRIGgered [:AMPLitude] <NRf+>, (@chanlist)	Sets the triggered output voltage
:BWIDth LOW HIGH1 HIGH2 HIGH3, (@chanlist)	Sets the voltage bandwidth (only on N678xA SMU)
:LIMit	
[:POSitive]	
[:IMMEDIATE][:AMPLitude] <NRf+>, (@chanlist)	Sets the positive voltage limit (only on N678xA SMU)
:COUple <Bool>, (@chanlist)	Sets the voltage limit tracking state (only on N6784A)
:NEGative	
[:IMMEDIATE][:AMPLitude] <NRf+>, (@chanlist)	Sets the negative voltage limit (only on N6784A)
:MODE FIXed STEP LIST, (@chanlist)	Sets the voltage trigger mode
:PROTection	
[:LEVel] <NRf+>, (@chanlist)	Sets the over-voltage protection level
:DELay[:TIME] <NRf+>, (@chanlist)	Sets the over-voltage protection delay (only on N6783A)
:REMote	
[:POSitive][:LEVel] <NRf+>, (@chanlist)	Sets the positive remote OV protection level (only on N678xA SMU)
:NEGative[:LEVel] <NRf+>, (@chanlist)	Sets the negative remote OV protection level (only on N6784A)
:TRACking	(Tracking commands only on Option J01)
[:STATe] <Bool>, (@chanlist)	Enables/disables tracking OVP
:OFFSet <NRf+>, (@chanlist)	Sets the tracking OVP offset
:RANGe <NRf+>, (@chanlist)	Sets the output voltage range
:SLEW	
[:IMMEDIATE] <NRf+> INFinity, (@chanlist)	Sets the output voltage slew rate
:MAXimum <Bool>, (@chanlist)	Enables/disables the maximum slew rate override

SCPI Command	Description
STATus	
:OPERation	
[:EVENT]? (@chanlist)	Returns the value of the operation event register
:CONDition? (@chanlist)	Returns the value of the operation condition register
:ENABle <NRf>, (@chanlist)	Enables specific bits in the Event register
:NTRansition <NRf>, (@chanlist)	Sets the Negative transition filter
:PTRansition <NRf>, (@chanlist)	Sets the Positive transition filter
:PRESet	Presets all enable and transition registers to power-on
:QUEStionable	
[:EVENT]? (@chanlist)	Returns the value of the questionable event register
:CONDition? (@chanlist)	Returns the value of the questionable condition register
:ENABle <NRf>, (@chanlist)	Enables specific bits in the Event register
:NTRansition <NRf>, (@chanlist)	Sets the Negative transition filter
:PTRansition <NRf>, (@chanlist)	Sets the Positive transition filter
SYSTem	
:CHANnel	
[:COUNT]?	Returns the number of output channels in a mainframe
:MODEl? (@chanlist)	Returns the model number of the selected channel
:OPTion? (@chanlist)	Returns the option installed in the selected channel
:SERial? (@chanlist)	Returns the serial number of the selected channel
:COMMunicate	
:RLState LOCal REMote RWLock	Specifies the Remote/Local state of the instrument
:TCPip:CONTRol?	Returns the control connection port number
:ERRor?	Returns the error number and error string
:GROup	
:CATalog?	Returns the groups that have been defined
:DEFine (@chanlist)	Group multiple channels to create a single output
:DELete <channel>	Removes the specified channel from a group
:ALL	Ungroups all channels
:PASSword:FPANel:RESet	Resets the front panel lock password to zero
:REBoot	Returns the unit to its power-on state
:VERSion?	Returns the SCPI version number
TRIGger	
:ACQuire (Acquire commands only on N676xA, N678xA SMU and Option 054)	
[:IMMEDIATE] (@chanlist)	Triggers the measurement immediately
:CURRent	
[:LEVel] <NRf>, (@chanlist)	Sets the current trigger level
:SLOPe POSitive NEGative, (@chanlist)	Sets the current trigger slope
:SOURce BUS CURRent<1-4> EXTernal PIN<1-7> TRANsient<1-4> VOLTage<1-4>, (@chanlist)	Sets the measurement trigger source
:TOUTput[:ENABle] <Bool>, (@chanlist)	Enables measurement triggers to be sent to a digital port pin
:VOLTage	
[:LEVel] <NRf>, (@chanlist)	Sets the voltage trigger level
:SLOPe POSitive NEGative, (@chanlist)	Sets the voltage trigger slope
:ELOG	
[:IMMEDIATE] (@chanlist)	Triggers the external data log immediately
:SOURce BUS EXTernal IMMEDIATE PIN<1-7>, (@chanlist)	Sets the external data log trigger source
:TRANsient	
[:IMMEDIATE] (@chanlist)	Triggers the output immediately
:SOURce BUS EXTernal IMMEDIATE PIN<1-7> TRANsient<1-4>, (@chanlist)	Sets the output trigger source

Common Commands

Command	Description	Command	Description
*CLS	Clear status	*RDT?	Return output channel descriptions
*ESE <NRf>	Standard event status enable	*RST	Reset
*ESR?	Return event status register	*SAV <NRf>	Saves an instrument state
*IDN?	Return instrument identification	*SRE <NRf>	Set service request enable register
*LRN	Returns a sequence of SCPI commands	*STB?	Return status byte
*OPC	Enable "operation complete" bit in ESR	*TRG	Trigger
*OPT?	Return option number	*TST?	Performs self-test, then returns result
*RCL <NRf>	Recalls a saved instrument state	*WAI	Waits until all device commands are done

Non-Volatile Settings

The following tables show the factory-shipped non-volatile settings of the instrument. Information in non-volatile memory is **NOT** lost when power is turned off. These settings are all customer-configurable.

The factory-shipped LAN settings can be restored by selecting the front panel Reset control located in the System\I/O\LAN\Config\Reset menu.

All non-volatile settings including LAN, can be restored by selecting the front panel Reset control located in the System\Admin\Nvram menu

Factory-shipped non-volatile LAN settings			
Get IP Address	Automatic	Dynamic DNS naming service	Enabled
IP Address	169.254.67.0	NetBIOS naming service	Enabled
Subnet Mask	255.255.0.0	Domain name	Blank
Default Gateway	0.0.0.0	TCP keepalive	Enabled
Obtain DNS server from DHCP	Enabled	TCP keepalive seconds	1800
DNS server	Blank	Ethernet Auto-negotiation	Enabled
Host name	A-N67xxx-xxxxx	Ping server	Enabled
		Web password	Blank

Other factory-shipped non-volatile settings			
Admin/Calibration password	0 (zero)	On/Off key affects all channels	Disabled
Calibration date	March 5, 2003	Output Inhibit mode	Off
Channel grouping	No groups	Saved states	*RST command
Digital port function (all pins)	Digital In	Screen contrast	50%
Digital port polarity (all pins)	Positive	Screen saver	Enabled
Front panel lockout	Disabled	Screen saver delay	60 minutes
Front panel meter view	1-channel	USB interface	Enabled
GPIB Address	5	Wake on I/O	Enabled
Key clicks	Enabled	Web server	Enabled
LAN interface	Enabled		

Reset Settings (*RST)

CAL:STAT	OFF	SENS:ELOG:CURR:RANG:AUTO	OFF
CURR	0.08 or MIN	SENS:ELOG:FUNC:CURR	ON
CURR:LIM	MAX	SENS:ELOG:FUNC:CURR:MINM	OFF
CURR:LIM:COUP	ON	SENS:ELOG:FUNC:VOLT	OFF
CURR:LIM:NEG	MIN	SENS:ELOG:FUNC:VOLT:MINM	OFF
CURR:MODE	FIX	SENS:ELOG:PER	0.1
CURR:PROT:DEL	0.02	SENS:ELOG:VOLT:RANG:AUTO	OFF
CURR:PROT:DEL:STAR	SCH	SENS:FUNC	"VOLT"
CURR:PROT:STAT	OFF	SENS:FUNC:CURR	OFF
CURR:RANG	MAX	SENS:FUNC:VOLT	ON
CURR:SLEW	9.9E+37	SENS:FUNC:VOLT:INP	MAIN
CURR:SLEW:MAX	ON	SENS:SWE:POIN	1024 or 4883
CURR:TRIG	MIN	SENS:SWE:OFFS:POIN	0
DIG:OUTP:DATA	0	SENS:SWE:TINT	20.48E-6
DISP:VIEW	METER1	SENS:SWE:TINT:RES	RES20
INIT:CONT:TRAN	OFF	SENS:VOLT:RANG	MAX
LIST:COUN	1	SENS:VOLT:RANG:AUTO	OFF
LIST:CURR	MIN	SENS:WIND	RECT
LIST:DWEL	0.001	STEP:TOUT	FALSE
LIST:STEP	AUTO	TRIG:ACQ:CURR	MIN
LIST:TERM:LAST	OFF	TRIG:ACQ:CURR:SLOP	POS
LIST:TOUT:BOST	OFF	TRIG:ACQ:SOUR	BUS
LIST:TOUT:EOST	OFF	TRIG:ACQ:TOUT	OFF
LIST:VOLT	MIN	TRIG:ACQ:VOLT	MIN
OUTP	OFF	TRIG:ACQ:VOLT:SLOP	POS
OUTP:COUP	OFF	TRIG:ELOG:SOUR	BUS
OUTP:DEL:FALL	0	TRIG:TRAN:SOUR	BUS
OUTP:DEL:RISE	0	VOLT	MIN
OUTP:PMOD	VOLT	VOLT:BWID	LOW
OUTP:TMOD	LOWZ	VOLT:LIM	MAX
OUTP:PROT:COUP	OFF	VOLT:LIM:COUP	ON
OUTP:PROT:DEL	0.02	VOLT:LIM:NEG	MIN
OUTP:PROT:OSC	ON	VOLT:MODE	FIX
OUTP:PROT:WDOG	OFF	VOLT:PROT:DEL	0
OUTP:REL:POL	NORM	VOLT:PROT:REM	MAX
POW:LIM	MAX	VOLT:PROT:REM:NEG	MIN
RES	0	VOLT:RANG	MAX
RES:STAT	OFF	VOLT:SLEW	9.9E+37
SENS:CURR:CCOM	ON	VOLT:SLEW:MAX	ON
SENS:CURR:RANG	MAX	[SOUR:]VOLT:TRIG	MIN
SENS:CURR:RANG:AUTO	OFF		

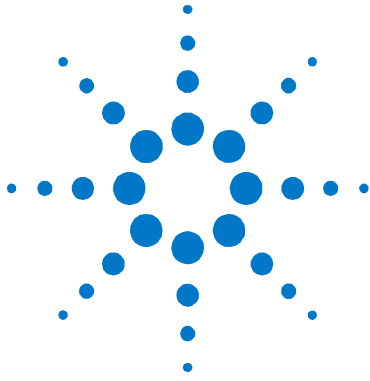

5 Programming Examples

Output Programming Example	332
List Programming Example	334
Digitizer Programming Example	336

This chapter contains several example programs to help you develop programs for your own application. The example programs are for illustration only, and are provided with the assumption that you are familiar with the programming language being demonstrated and the tools used to create and debug procedures. See chapter 3, “Commands by Subsystem” for the SCPI command syntax.

You have a royalty-free right to use, modify, reproduce and distribute the example programs (and/or any modified version) in any way you find useful, provided you agree that Agilent Technologies has no warranty, obligations, or liability for any example programs.

The example programs are written in Microsoft Visual Basic 6.0 using the VISA COM IO library. The VISA COM library must be downloaded from the Automation-Ready CD-ROM to use these programs. For information about using VISA COM in another Visual Basic project, refer to “Programming Your Instruments” in the *USB/LAN/GPIB Interfaces Connectivity Guide*, also included on the Automation-Ready CD-ROM.

NOTE

Example programs for the following programming environments are also included on the Product-Reference CD-ROM located at the back of this guide:

Microsoft Visual Basic 6.0

Microsoft Visual C++ 6.0

Microsoft Excel

Agilent VEE Pro

The CD also contains IVI-COM and VXIplug&play drivers for your instrument.

Output Programming Example

This is a simple program that sets a voltage, current, over-voltage, and the status of over-current protection. When done, the program checks for instrument error and gives a message if there is an error.

```

Sub output_programming_example()
  Dim IDN As String
  Dim GPIBaddress As String
  Dim ErrString As String

  ' This variable controls the channel number to be programmed
  Dim channel As String

  ' This variable controls the voltage
  Dim VoltSetting As Double

  ' This variable measures the voltage
  Dim MeasureVoltString As String

  ' This variable controls the current
  Dim CurrSetting As Double

  ' This variable controls the over voltage protection setting
  Dim overVoltSetting As Double

  'These variables are necessary to initialize the VISA COM.
  Dim ioMgr As AgilentRMLib.SRMCLs
  Dim Instrument As VisaComLib.FormattedIO488

  ' The following command line provides the program with the VISA name of the
  ' interface that it will communicate with. It is currently set to use GPIB.
  GPIBaddress = "GPIB0::5::INSTR"

  ' Use the following line instead for LAN communication
  ' TCPIPAddress="TCPIP0::141.25.36.214"

  ' Use the following line instead for USB communication
  ' USBaddress = "USB0::2391::1799::US00000002"

  ' Initialize the VISA COM communication
  Set ioMgr = New AgilentRMLib.SRMCLs
  Set Instrument = New VisaComLib.FormattedIO488
  Set Instrument.IO = ioMgr.Open(GPIBaddress)

  ' The next three command lines set the voltage, current, and over voltage
  VoltSetting = 3
  CurrSetting = 1.5                               ' amps
  overVoltSetting = 10

  ' This variable can be changed to program any channel in the mainframe
  channel = "@1"                                   ' channel 1

  With Instrument
    ' Send a power reset to the instrument
    .WriteString "*RST"

    ' Query the instrument for the IDN string
    .WriteString "*IDN?"
    IDN = .ReadString
  End With
End Sub

```

```

' Set the voltage
.WriteString "VOLT" & Str$(VoltSetting) & "," & channel

' Set the over voltage level
.WriteString "VOLT:PROT:LEV " & Str$(overVoltSetting) & "," & channel

' Set current level
.WriteString "CURR " & Str$(CurrSetting) & "," & channel

' Turn on over current protection
.WriteString "CURR:PROT:STAT ON," & channel

' Turn the output on
.WriteString "OUTP ON," & channel

' Wait for previous commands to complete.
.WriteString "*OPC?"
.ReadString

' Measure the voltage
.WriteString "MEAS:VOLT? " & channel
MeasureVoltString = .ReadString
MsgBox "Measured Voltage is " & MeasureVoltString & "At channel" & channel

' Check instrument for any errors
.WriteString "Syst:err?"
ErrString = .ReadString

' give message if there is an error
If Val(ErrString) Then
    MsgBox "Error in instrument!" & vbCrLf & ErrString
End If
End With

End Sub

```

List Programming Example

This program executes a 10 point current and voltage list. It also specifies 10 different dwell times. When done, the program checks for instrument error and gives a message if there is an error.

```

Sub list_programming_example()
  Dim IDN As String
  Dim GPIBAddress As String
  Dim ErrString As String
  Dim channel As String

  'These variable are necessary to initialize the VISA COM.
  Dim ioMgr As AgilentRMLib.SRMCLs
  Dim Instrument As VisaComLib.FormattedIO488

  ' The following command line provides the program with the VISA name of the
  ' interface that it will communicate with. It is currently set to use GPIB.
  GPIBAddress = "GPIB1::5::INSTR"

  ' Use the following line instead for LAN communication
  ' TCPIPAddress="TCPIP0::141.25.36.214"

  ' Use the following line instead for USB communication
  ' USBAddress = "USB0::2391::1799::US00000002"

  ' Initialize the VISA COM communication
  Set ioMgr = New AgilentRMLib.SRMCLs
  Set Instrument = New VisaComLib.FormattedIO488
  Set Instrument.IO = ioMgr.Open(GPIBAddress)

  ' These next three strings are the points in the list.
  ' All three strings are the same length.
  ' The first one controls voltage, the second current, and the third dwell time
  Const voltPoints = "1,2,3,4,5,6,7,8,9,10"
  Const currPoints = "0.5,1,1.5,2,2.5,3,3.5,4,4.5,5"
  Const dwellPoints = "1,2,0.5,1,0.25,1.5,0.1,1,0.75,1.2"

  ' This variable can be changed to program any channel in the mainframe
  channel = "(@1)" ' channel 1

  With Instrument
    ' Send a power reset to the instrument
    .WriteString "*RST"

    ' Query the instrument for the IDN string
    .WriteString "*IDN?"
    IDN = .ReadString

    ' Set the voltage mode to list
    .WriteString "VOLT:MODE LIST," & channel

    ' Set the current mode to list
    .WriteString "CURR:MODE LIST," & channel

    ' Send the voltage list points
    .WriteString "LIST:VOLT " & voltPoints & "," & channel

    ' Send the Current list points
    .WriteString "LIST:CURR " & currPoints & "," & channel
  End With
End Sub

```

```
' Send the dwell points
.WriteString "LIST:DWEL " & dwellPoints & ", " & channel

' Turn the output on
.WriteString "OUTP ON," & channel

' Wait for output to settle in the ON state.
.WriteString "*OPC?"
.ReadString

' Set the trigger source to bus
.WriteString "TRIG:TRAN:SOUR BUS," & channel

' Initiate the transient system
.WriteString "INIT:TRAN " & channel

' Trigger the unit
.WriteString "*TRG"

' Check instrument for any errors
.WriteString "Syst:err?"
ErrString = .ReadString

' give message if there is an error
If Val(ErrString) Then
    MsgBox "Error in instrument!" & vbCrLf & ErrString
End If
End With

End Sub
```

Digitizer Programming Example

This program uses the voltage in step mode and also demonstrates how to set up and use the digitizer. When done, the program checks for instrument error and gives a message if there is an error.

```

Sub digitizer_programming_example()
  Dim IDN As String
  Dim GPIBaddress As String
  Dim ErrString As String
  Dim channel As String
  Dim measPoints As Long
  Dim measOffset As Long
  Dim VoltSetting As Double
  Dim finalVoltage As Double
  Dim timeInterval As Double
  Dim VoltPoints() As Variant
  Dim i As Long
  Const WTG_MEAS = 8
  Const WTG_TRANS = 16

  'These variables are necessary to initialize the VISA COM.
  Dim ioMgr As AgilentRMLib.SRMCLs
  Dim Instrument As VisaComLib.FormattedIO488

  ' The following command line provides the program with the VISA name of the
  ' interface that it will communicate with. It is currently set to use GPIB.
  GPIBaddress = "GPIB0::5::INSTR"

  ' Use the following line instead for LAN communication
  ' TCPIPAddress="TCPIP0::141.25.36.214"

  ' Use the following line instead for USB communication
  ' USBAddress = "USB0::2391::1799:US00000002"

  ' Initialize the VISA COM communication
  Set ioMgr = New AgilentRMLib.SRMCLs
  Set Instrument = New VisaComLib.FormattedIO488
  Set Instrument.IO = ioMgr.Open(GPIBaddress)

  ' This controls the number of points the measurement system measures
  measPoints = 100

  ' This controls the number of points to offset the measurement (positive for
  ' forward, negative for reverse)
  measOffset = 0

  ' This sets the time between points
  timeInterval = 0.0025

  ' This controls the voltage
  VoltSetting = 5

  ' This is the final voltage that will be triggered
  finalVoltage = 10

  ' This variable can be changed to program any channel in the mainframe
  channel = "@1)"          ' channel 1

```



```

With Instrument
' Send a power reset to the instrument
.WriteString "*RST"

' Query the instrument for the IDN string
.WriteString "*IDN?"
IDN = .ReadString

' Put the Voltage into step mode which causes it to transition from one
' voltage to another upon receiving a trigger
.WriteString "VOLT:MODE STEP," & channel

' Set the voltage
.WriteString "VOLT" & Str$(VoltSetting) & "," & channel

' Go to final value
.WriteString "VOLT:TRIG" & Str$(finalVoltage) & "," & channel

' Turn the output on
.WriteString "OUTP ON," & channel

' Wait for output to turn on.
.WriteString "*OPC?"
.ReadString

' Set the bus as the transient trigger source
.WriteString "TRIG:TRAN:SOUR BUS," & channel

' Set the number of points for the measurement system to use as an offset
.WriteString "SENS:SWE:OFFS:POIN" & Str$(measOffset) & "," & channel

' Set the number of points that the measurement system uses
.WriteString "SENS:SWE:POIN" & Str$(measPoints) & "," & channel

' Set the time interval between points
.WriteString "SENS:SWE:TINT" & Str$(timeInterval) & "," & channel

' Set the measurement trigger source
.WriteString "TRIG:ACQ:SOUR BUS," & channel

' Initiate the measurement trigger system
.WriteString "INIT:ACQ " & channel

' Initiate the transient trigger system
.WriteString "INIT:TRAN " & channel

' Wait for INITiate commands to complete
Do
    .WriteString "STAT:OPER:COND? " & channel
    Status = .ReadString
Loop Until (Status And (WTG_MEAS + WTG_TRANS)) = (WTG_MEAS + WTG_TRANS)

' Trigger the unit
.WriteString "*TRG"

' Read back the voltage points
.WriteString "FETC:ARR:VOLT? " & channel
VoltPoints = .ReadList

' Print the first 10 voltage points
For i = 0 To 9
    Debug.Print i, VoltPoints(i)
Next i

```

5 Programming Examples

```
' Check instrument for any errors
.WriteString "Syst:err?"
ErrString = .ReadString

' give message if there is an error
If Val(ErrString) Then
    MsgBox "Error in instrument!" & vbCrLf & ErrString
End If
End With

End Sub
```

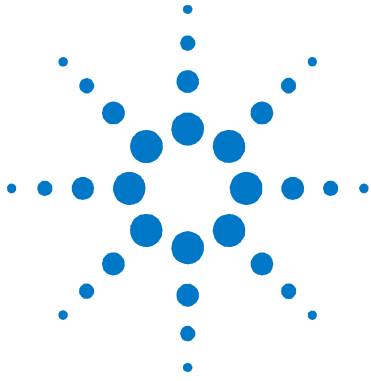

6 SCPI Error Messages

Introduction	340
Error List	340

This appendix gives the error numbers and descriptions that are returned by the Agilent N6700.

Introduction

The front-panel ERR annunciator turns on when one or more errors are currently stored in the error queue.

Errors are retrieved in first-in-first-out (FIFO) order. The first error returned is the first error that was stored.

Errors are cleared as you read them. When you have read all errors from the error queue, the ERR annunciator turns off and the errors are cleared.

If more errors have occurred than can fit in the buffer, the last error stored in the queue (the most recent error) is replaced with -350,"Error queue overflow". No additional errors are stored until you remove errors from the queue. If no errors have occurred when you read the error queue, the instrument responds with +0,"No error".

The error queue is cleared by the *CLS (Clear Status) command and when power is cycled. The errors are also cleared when you read the error queue. The error queue is not cleared by a Factory Reset (*RST command) or an Instrument Preset (SYSTem:PRESet command).

Front-Panel Operation:

If the ERR annunciator is on, press the Error key to view the errors. Use the navigation keys to scroll through the error list. All errors are cleared when you exit the menu.

Remote Interface Operation:

SYSTem:ERRor? Reads and clears one error from the queue
 Errors have the following format (the error string may contain up to 80 characters):
 -113,"Undefined header"

Error List

Error	Device-dependent Errors (these errors set Standard Event Status register bit #3)
0	No error This is the response to the ERR? query when there are no errors.
100	Too many channels You have specified more channels than are installed in the mainframe.
101	Calibration state is off Calibration is not enabled. The instrument will not accept calibration commands.
102	Calibration password is incorrect The calibration password is incorrect.
103	Calibration is inhibited by switch setting Calibration mode is locked out by the calibration switch.
104	Bad sequence of calibration commands Calibration commands have not been entered in the proper sequence.

Device-dependent Errors (continued)	
105	<p>Unexpected output current The measured output current is outside the acceptable range.</p>
106	<p>Zero measurement out of range error The "zero" measurement value is outside the acceptable range.</p>
107	<p>Programming cal constants out of range The programmed calibration constant is outside the acceptable range.</p>
108	<p>Measurement cal constants out of range The measurement calibration constant is outside the acceptable range.</p>
109	<p>Over voltage cal constants out of range The over voltage calibration constant is outside the acceptable range.</p>
110	<p>Wrong V+I The instrument was unable to set the correct voltage or current value.</p>
111	<p>Aux vloc cal constants out of range Calibration constants on the internal auxiliary local ADC are outside the acceptable range.</p>
112	<p>Aux vrem cal constants out of range Calibration constants on the internal auxiliary remote ADC are outside the acceptable range.</p>
113	<p>Aux imon cal constants out of range Calibration constants on the internal auxiliary imon ADC are outside the acceptable range.</p>
114	<p>Wrong status An incorrect status function has been reported.</p>
116	<p>Locked out by internal switch setting This function has been locked out by an internal switch in the mainframe.</p>
117	<p>Calibration error A calibration error has occurred. Do not save calibration constants. Try re-calibrating the unit.</p>
200	<p>Hardware error channel <channel> A hardware error has occurred on the specified channel.</p>
201	<p>Invalid configuration, empty slots There is an empty slot between modules. This configuration is not allowed.</p>
202	<p>Selftest Fail A selftest failure has occurred. See selftest failure list for details.</p>
203	<p>Compatibility function not implemented The requested compatibility function is not available.</p>
204	<p>NVRAM checksum error A checksum error has occurred in the instrument's nonvolatile random access memory.</p>
205	<p>NVRAM full The nonvolatile random access memory of the instrument is full.</p>
206	<p>File not found The internal calibration file or the internal channel attribute file was not found in NVRAM.</p>
207	<p>Cal file version error The calibration file was written or read using old firmware. Firmware must be updated.</p>
208	<p>Running backup firmware The instrument is presently running the backup (previous) version of the firmware.</p>
209	<p>Modules do not match group NV config One or more modules that have their output coupled do not match the instrument state settings.</p>
210	<p>Frame NVRAM error A non-volatile RAM error has occurred in the mainframe</p>

Device-dependent Errors (continued)	
211	Output state couple modules do not match One or more modules in the group does not match the non-volatile configurations settings.
302	Option not installed The option that is programmed by this command is not installed.
303	There is not a valid acquisition to fetch from There is no valid data in the measurement buffer.
304	Volt and curr in incompatible transient modes Voltage and current cannot be in Step and List mode at the same time.
305	A triggered value is on a different range A triggered value is on a different range than the one that is presently set.
306	Too many list points Too many list points have been specified.
307	List lengths are not equivalent One or more lists are not the same length.
308	This setting cannot be changed while transient trigger is initiated Setting cannot be changed while the instrument is waiting for or executing a trigger sequence.
309	Cannot initiate, voltage and current in fixed mode Cannot initiate transient generator. Either the voltage or current function is set to Fixed mode.
310	The command is not supported by this model This power modules either does not have the hardware capability or the options required to support this command.
311	This group of channel has non-identical features One or more modules in this group does not match the ratings or options of the other modules.
312	The command is disabled when the channel is grouped This command is disabled when the output channel is grouped.
315	Settings conflict error A data element could not be programmed because of the present instrument state.
320	Firmware update error This may be due to the instrument hardware not being able to support the firmware version.
Command Errors (these errors set Standard Event Status register bit #5)	
-100	Command error Generic syntax error.
-101	Invalid character An invalid character was found in the command string.
-102	Syntax error Invalid syntax was found in the command string. Check for blank spaces.
-103	Invalid separator An invalid separator was found in the command string. Check for proper use of , ; :
-104	Data type error A different data type than the one allowed was found in the command string.
-105	GET not allowed A group execute trigger is not allowed in a command string.
-108	Parameter not allowed More parameters were received than were expected.
-109	Missing parameter Fewer parameters were received than were expected.

Command Errors (continued)	
-110	Command header error An error was detected in the header.
-111	Header separator error A character that was not a valid header separator was found in the command string.
-112	Program mnemonic too long The header contains more than 12 characters.
-113	Undefined header A command was received that was not valid for this instrument.
-114	Header suffix out of range The value of the numeric suffix is not valid.
-120	Numeric data error Generic numeric data error.
-121	Invalid character in number An invalid character for the data type was found in the command string.
-123	Exponent too large The magnitude of the exponent was larger than 32000.
-124	Too many digits The mantissa of a numeric parameter contained more than 255 digits, excluding leading zeros.
-128	Numeric data not allowed A numeric parameter was received but a character string was expected.
-130	Suffix error Generic suffix error
-131	Invalid suffix A suffix was incorrectly specified for a numeric parameter.
-134	Suffix too long The suffix contains more than 12 characters.
-138	Suffix not allowed A suffix is not supported for this command.
-140	Character data error Generic character data error
-141	Invalid character data Either the character data element contains an invalid character, or the element is not valid.
-144	Character data too long The character data element contains more than 12 characters.
-148	Character data not allowed A discrete parameter was received, but a string or numeric parameter was expected.
-150	String data error Generic string data error
-151	Invalid string data An invalid character string was received. Check that the string is enclosed in quotation marks.
-158	String data not allowed A character string was received, but is not allowed for this command.
-160	Block data error Generic block data error
-161	Invalid block data The number of data bytes sent does not match the number of bytes specified in the header.

Command Errors (continued)	
-168	Block data not allowed Data was sent in arbitrary block format but is not allowed for this command.
-170	Expression error Generic expression error
-171	Invalid expression data The expression data element was invalid.
-178	Expression data not allowed Expression data element was sent but is not allowed for this command.
Execution Errors (these errors set Standard Event Status register bit #4)	
-200	Execution error Generic syntax error
-220	Parameter error A data element related error occurred.
-221	Settings conflict A data element could not be executed because of the present instrument state.
-222	Data out of range A data element could not be executed because the value was outside the valid range.
-223	Too much data A data element was received that contains more data than the instrument can handle.
-224	Illegal parameter value An exact value was expected but not received.
-225	Out of memory The device has insufficient memory to perform the requested operation.
-226	Lists not same length One or more lists are not the same length.
-230	Data corrupt or stale Possible invalid data. A new reading was started but not completed.
-231	Data questionable The measurement accuracy is suspect.
-232	Invalid format The data format or structure is inappropriate.
-233	Invalid version The version of the data format is incorrect to the instrument.
-240	Hardware error The command could not be executed because of a hardware problem with the instrument.
-241	Hardware missing The command could not be executed because of missing hardware, such as an option.
-260	Expression error An expression program data element related error occurred.
-261	Math error in expression An expression program data element could not be executed due to a math error.
Query Errors (these errors set Standard Event Status register bit #2)	
-400	Query Error Generic error query
-410	Query INTERRUPTED A condition causing an interrupted query error occurred.

Query Errors (continued)	
-420	Query UNTERMINATED A condition causing an unterminated query error occurred.
-430	Query DEADLOCKED A condition causing a deadlocked query error occurred.
-440	Query UNTERMINATED after indefinite response A query was received in the same program message after a query indicating an indefinite response was executed.

Selftest Errors (these errors set Standard Event Status register bit #3)	
202	Selftest Fail Aux Adc 0 expected <n1> to <n2>, measured <n3>, chan <n4> Auxiliary ADC failed. n1 and n2 are the expected limits. n3 is the measured value. n4 is the channel location of the failed module.
202	Selftest Fail DACs 0 expected <n1> to <n2>, measured <n3>, chan <n4> Both voltage and current DACs are at zero. n1 and n2 are the expected limits. n3 is the measured value. n4 is the channel location of the failed module.
202	Selftest Fail DACs 1 expected <n1> to <n2>, measured <n3>, chan <n4> Voltage DAC is at zero; current DAC is at full scale. n1 and n2 are the expected limits. n3 is the measured value. n4 is the channel location of the failed module.
202	Selftest Fail DACs 2 expected <n1> to <n2>, measured <n3>, chan <n4> Voltage DAC is at full scale; current DAC is at zero. n1 and n2 are the expected limits. n3 is the measured value. n4 is the channel location of the failed module.
202	Selftest Fail DACs 3 expected <n1> to <n2>, measured <n3>, chan <n4> Both voltage and current DACs are at full scale. n1 and n2 are the expected limits. n3 is the measured value. n4 is the channel location of the failed module.

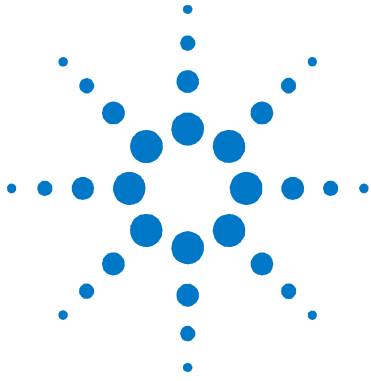

7

Agilent 662xA Compatibility

Differences – In General	348
Compatibility Command Summary	349

The Agilent N6700 Modular Power System is programmatically compatible with the Agilent 6621A – 6629A DC power supplies. This means that you can program the power system using the same commands that are used to program the Agilent 662xA power supplies.

Agilent 662xA commands will only work in mainframes that contain combinations of Agilent N675xA or N676xA power modules.

NOTE

Agilent 662xA commands will NOT work in mainframes that contain any Agilent of N673xA/B, N674xA/B, N677xA, or N678XA power modules. This is true even if the mainframes also contain Agilent N675xA or N676xA power modules.

Differences – In General

The following table documents the general differences between the way Compatibility programming commands work on the Agilent N6700 Modular Power System and the way they work on the Agilent 662xA series DC power supplies.

Item	Differences
Queries	<p>The Agilent N67xxA modules will respond to multiple queries.</p> <p>It will not allow a space separator between numbers.</p> <p>It will not allow a user to query information, read back only a portion of the information, send another command, and finish reading back the information from the original query.</p> <p>Sending a second query without reading the response to the first will generate an error.</p> <p>Model number queries will only return the N6700 model number.</p>
Status functions	<p>Serial Poll will be controlled by the SCPI status model and will not act like a 662xA serial poll.</p> <p>SRQ will be controlled by the SCPI status model.</p> <p>Parallel poll will not work.</p> <p>The Agilent N67xxA modules will never set the CC- bit. All other status bits are translated to the closest 662xA bits.</p>
Settings	<p>The full-scale limits will match the Agilent N67xxA module limits.</p> <p>There is no automatic setting adjustment.</p>
Measurement	<p>Measurements use the present settings for points, time interval, etc.</p> <p>Floating point numbers returned by the power system may not have exactly the same syntax or number of digits.</p>
Calibration	<p>Calibration must be done in SCPI.</p>
Storage states	<p>The Agilent N67xxA modules have 2 non-volatile states and 9 volatile states. The 9 volatile states are only available when using compatibility commands.</p>
Protection functions	<p>OVRST and OCRST will reset all latched protection functions, not just over-voltage or over-current.</p>

Compatibility Command Summary

The following table documents the compatibility commands that the Agilent N6700 MPS supports. All compatibility commands are accepted; however, some commands will generate an error.

Agilent 662xA Command	Description	Similar SCPI Command
ASTS? <ch>	Queries the accumulated status (ASTS) of the specified output channel. The response represents the sum of the binary weights of the ASTS register bits. The ASTS register is automatically set to the present status after being queried.	STAT:OPER:EVEN? STAT:QUES:EVEN? *ESE?
CLR	Returns the entire power system (all outputs) to the power-on state, except the unit is not unaddressed and its store/recall registers are not changed.	*RST
CMODE <on/off>	Generates error –113. The unit must be calibrated using SCPI commands.	see Appendix B
CMODE?	Generates error –113. The unit must be calibrated using SCPI commands.	see Appendix B
DC <ch>, < on/off >	Turns the specified output channel on or off. On/off = 0 turns the channel off; on/off = 1 turns the channel on.	OUTP:STAT
DC? <ch>	Queries whether the specified output channel is on or off. Response is either 1 (on) or 0 (off).	OUTP:STAT?
DPCON < on/off >	Sets the power-on state of the output channels. For on/off = 0, all outputs will be off state when the unit is turned on. For on/off = 1 all outputs will be in the on state when the power system is turned on. This command requires the output power-on state to be set to RCL0.	OUTP:PON:STAT RCL0
DPCON?	Returns a 1 if any channels are set to turn on their output at power on.	OUTP:PON:STAT?
DLY <ch>, <delay>	Sets the reprogramming delay for the specified output channel. This delay is used to mask the CV, CC, CP-, UNR, and other status bits from the fault register and the OCP function for the specified delay period.	OUTP:PROT:DEL
DLY? <ch>	Queries the present reprogramming delay of the specified output channel.	OUTP:PROT:DEL?
DSP <on/off>	Does nothing.	None
DSP?	Always returns a 1.	None
DSP "xxxxxxxxxxx"	Does nothing.	None
ERR?	Queries the present programming or hardware error. An error code number is returned over the GPIB to identify the error.	SYST:ERR?
FAULT? <ch>	Queries the fault register of the specified output channel. A bit is set in the fault register when the corresponding bit in both the status and the mask registers. The response is an integer 0 to 255. The fault register is cleared after being read.	STAT:OPER? STAT:QUES? *ESE?
ID?	Queries the model number of the power system.	*IDN?
IDATA <ch>, <llo>, <lhi>	Generates error –113. Unit must be calibrated using SCPI commands.	see Appendix B

Agilent 662xA Command	Description	Similar SCPI Command
IHI <ch>	Generates error –113. Unit must be calibrated using SCPI commands.	see Appendix B
ILO <ch>	Generates error –113. Unit must be calibrated using SCPI commands.	see Appendix B
IOUT? <ch>	Queries the measured output current of the specified output channel. The response is a real number. The front panel display can be used to monitor the measured output current (and voltage) of the selected output channel.	MEAS:CURRE?
IRLO <ch>	Generates error –113.	None
IRHI <ch>	Generates error –113.	None
IRLN <ch>	Generates error –113.	None
IRHN <ch>	Generates error –113.	None
IRSET <ch>, <x>	Sets the full-scale current range programming for an output channel. The power system will select the lowest operating range that will contain the value (x). If the present operating current is greater than the full-scale range selected, the present output current will be reduced to the full-scale value of the new range selected. If the current entered is larger than the highest possible range, an error will result.	SENS:CURRE:RANG
IRSET? <ch>	Queries the full-scale current range setting of an output channel.	SENS:CURRE:RANG?
ISET <ch>, <current>	Sets the current of the specified output channel.	CURRE
ISET? <ch>	Queries the present current setting of the specified output channel. The response is a real number.	CURRE?
ISTEP <ch>, <x>	Increases or decreases the output channel current in steps. If the step value <x> is positive, output current will increase by the step value, if the step value is negative, the output current will decrease by the step value. Stepping beyond the active operating range causes an error.	LIST:CURRE
METER <ch>	Does nothing.	None
METER?	Always returns a 1.	None
OCP <ch>, <on/off>	Enables the over-current protection circuit for the specified output channel. This circuit, when enabled, causes the output to go to the off state when the output is in + CC mode. On/off is a 1 to turn on (enable) or a 0 to turn off (disable) the circuit.	CURRE:PROT:STAT
OCP? <ch>	Queries the over-current protection circuit on/off status for the specified output channel. Response is either a 1 (on) or a 0 (off).	CURRE:PROT:STAT?
OCRST <ch>	Returns the specified output channel to its previous settings after it has been turned off by a protection shutdown.	OUTP:PROT:CLE
OUT <ch>, <on/off>	Turns the specified output channel on or off. <on/off> equals 1 to turn the output on and equals 0 to turn the output off.	OUTP
OUT? <ch>	Queries whether the specified output channel is turned on or off. The response is either 1 (on) or 0 (off).	OUTP?

Agilent 662xA Command	Description	Similar SCPI Command
OVCAL < ch >	Generates error –113. Unit must be calibrated using SCPI commands.	see Appendix B
OVRST < ch >	Returns the specified output channel to its previous settings after it has been turned off by a protection shutdown.	OUTP:PROT:CLE
OVSET <ch>, <ovpoint>	Sets the over-voltage trip point for the specified output channel.	VOLT:PROT:LEV
OVSET? < ch >	Queries the present over-voltage setting of the specified output channel. The response is a real number.	VOLT:PROT:LEV?
PON < on/off >	Does nothing.	*SRE
PON?	Always returns a 0.	*SRE?
RCL < reg >	Recalls the settings for all output channels from the specified internal register. These settings were previously stored using the STO command. RCL programs all output channels in sequential order to these stored settings.	*RCL
RELAY < on/off >	Generates error 203. This Option 750 capability is not supported.	None
RELAY?	Generates error 203. This Option 750 capability is not supported.	None
RIRST < ch >	Resets all protection functions for the specified channel. This Option 750 capability is supported	OUTP:PROT:CLE
ROM?	Queries the revision of the power system's firmware.	*IDN?
SROM?	Queries the revision of the power system's firmware.	*IDN?
SRQ < setting >	Does nothing.	*SRQ
SRQ?	Always returns a 0.	*SRQ?
STO <reg>	Stores the present settings for all output channels in the specified register. These settings can be recalled when desired.	*SAV
STS? <ch>	Queries the present status of the specified output channel. The response represents the sum of the binary weights of the status register bits.	STAT:OPER:COND? STAT:QUES:COND?
TEST?	Always returns a 0.	*TST?
UNMASK <ch>, <setting>	Sets the bits in the mask register of the specified output channel to the setting. The setting is an integer that represents the sum of the binary weights of the bits. The mask register operates in conjunction with the status and fault registers.	STAT:OPER:NTR STAT:OPER:PTR STAT:QUES:NTR STAT:QUES:PTR
UNMASK? <ch>	Queries the present setting of the mask register of the specified output channel. The response is an integer from 0 to 255.	STAT:OPER:NTR? STAT:OPER:PTR? STAT:QUES:NTR? STAT:QUES:PTR?
VDATA <ch>, <Vlo>, <Vhi>	Generates error –113. Unit must be calibrated using SCPI commands.	see Appendix B
VHI <ch>	Generates error –113.	None
VLO <ch>	Generates error –113.	None

7 Agilent 662xA Compatibility

Agilent 662xA Command	Description	Similar SCPI Command
VMUX? <ch>, <input>	Generates error –113.	None
VOUT? <ch>	Queries the measured output voltage of the specified output channel. The response is a real number. The front panel display can be used to monitor the measured output voltage (and current) of the selected output channel.	MEAS:VOLT?
VRLO <ch>	Generates error –113.	None
VRHI <ch>	Generates error –113.	None
VRSET <ch>, <x>	Sets the full-scale voltage range programming for an output channel. The power system will select the lowest operating range that will contain the value (x). If the present operating voltage is greater than the full-scale range selected, the present output voltage will be reduced to the full-scale value of the new range selected. If the voltage entered is larger than the highest possible range, an error message will result.	None
VRSET? <ch>	Queries the full scale voltage range setting of an output channel.	None
VSET <ch>, <voltage>	Sets the voltage of the specified output channel.	VOLT
VSET? <ch>	Queries the present voltage setting of the specified output channel. The response is a real number.	VOLT?
VSTEP <ch>, <x>	Increases or decreases the output channel voltage in steps. If the step value < x > is positive, output voltage will increase by the step value, if the step value is negative, the output voltage will decrease by the step value. Trying to step beyond the operating range will cause a number range error.	LIST:VOLT

Index

	A		
abort commands.....	18	*RST.....	54
ABOR ACO.....	19	*SAV.....	55
ABOR ELOG.....	20	*SRE.....	56
ABOR TRAN.....	21	*STB.....	58
		*TRG.....	60
		*TST.....	61
		*WAI.....	62
	C	combining.....	11
calibrate		compatibility	
password.....	32	command summary.....	349
calibrate commands		differences.....	348
CAL CURR.....	23	models.....	347
CAL CURR LIM NEG.....	24	contact numbers.....	7
CAL CURR LIM POS.....	25	conventions used in this guide.....	14
CAL CURR MEAS.....	26	coupled commands.....	12
CAL CURR PEAK.....	27	current	
CAL DATA.....	28	measurement compensation.....	153
CAL DATE.....	29	measurement range.....	151
CAL DPR.....	30	output range.....	195
CAL LEV.....	31		
CAL PASS.....	32	D	
CAL RES.....	33	device clear.....	16
CAL SAVE.....	34	digitizer	
CAL STAT.....	35	programming example.....	336
CAL VOLT.....	37	display commands	
CAL VOLT CMRR.....	38	DISP CHAN.....	65
CAL VOLT LIM POS.....	39	DISP VIEW.....	64
CAL VOLT MEAS.....	40		
CAL VOLT MEAS AUX.....	41	E	
channel		error codes.....	340
parameter.....	13	displaying.....	340
range.....	13		
command		F	
combining.....	11	fetch commands	
completion.....	16	FETC ARR CURR?.....	84
coupling.....	12	FETC ARR POW?.....	86
synchronization.....	16	FETC ARR VOLT?.....	88
common commands.....	17	FETC CURR ACDC?.....	68
*CLS.....	43	FETC CURR HIGH?.....	69
*ESE.....	44	FETC CURR LOW?.....	71
*ESR.....	46	FETC CURR MAX?.....	73
*IDN?.....	48	FETC CURR MIN?.....	74
*LRN?.....	49	FETC CURR?.....	67
*OPC.....	50	FETC ELOG?.....	90
*OPT?.....	51	FETC POW?.....	75
*RCL.....	52	FETC VOLT ACDC?.....	77
*RDT?.....	53		

S	
SCPI	
command completion.....	16
common commands.....	42, 328
device clear.....	16
header path.....	10
message structure.....	12
message unit.....	13
multiple commands.....	10
program message.....	12
response message.....	12
subsystem commands.....	322
sense commands	
SENS CURR CCOM.....	153
SENS CURR RANG.....	151
SENS CURR RANG AUTO.....	152
SENS ELOG CURR RANG.....	154
SENS ELOG CURR RANG AUTO.....	155
SENS ELOG FUNC CURR.....	156
SENS ELOG FUNC CURR MINM.....	157
SENS ELOG FUNC VOLT.....	158
SENS ELOG FUNC VOLT MINM.....	159
SENS ELOG PER.....	160
SENS ELOG VOLT RANG.....	162
SENS ELOG VOLT RANG AUTO.....	163
SENS FUNC.....	164
SENS FUNC CURR.....	165
SENS FUNC VOLT.....	166
SENS FUNC VOLT INP.....	167
SENS SWE OFFS POIN.....	168
SENS SWE POIN.....	169
SENS SWE TINT.....	171, 173
SENS VOLT RANG.....	175
SENS VOLT RANG AUTO.....	176
SENS WIND.....	177
source commands	
[SOUR] CURR.....	180
[SOUR] CURR LIM	
COUP.....	185
NEG.....	186
POS.....	184
[SOUR] CURR MODE.....	188
[SOUR] CURR PROT DEL.....	189
[SOUR] CURR PROT DEL STAR.....	191
[SOUR] CURR PROT STAT.....	193
[SOUR] CURR RANG.....	195
[SOUR] CURR SLEW.....	197
[SOUR] CURR SLEW MAX.....	199
[SOUR] CURR TRIG.....	182
[SOUR] DIG INP DATA?.....	201
[SOUR] DIG OUTP DATA.....	202
[SOUR] DIG PIN<1-7> FUNC.....	203
[SOUR] DIG PIN<1-7> POL.....	205
[SOUR] DIG TOUT BUS.....	206
[SOUR] FUNC.....	207
[SOUR] LIST COUN.....	208
[SOUR] LIST CURR.....	209
[SOUR] LIST CURR POIN?.....	211
[SOUR] LIST DWEL.....	212
[SOUR] LIST DWEL POIN?.....	214
[SOUR] LIST STEP.....	215
[SOUR] LIST TERM LAST.....	217
[SOUR] LIST TOUT BOST.....	220
[SOUR] LIST TOUT BOST POIN.....	219
[SOUR] LIST TOUT EOST.....	223
[SOUR] LIST TOUT EOST POIN.....	222
[SOUR] LIST VOLT.....	225
[SOUR] LIST VOLT POIN?.....	227
[SOUR] POW LIM.....	228
[SOUR] RES.....	230
[SOUR] RES STAT.....	231
[SOUR] STEP TOUT.....	232
[SOUR] VOLT [IMM].....	233
[SOUR] VOLT BWID.....	237
[SOUR] VOLT LIM COUP.....	240
[SOUR] VOLT LIM NEG.....	241
[SOUR] VOLT LIM POS.....	239
[SOUR] VOLT MODE.....	243
[SOUR] VOLT PROT.....	244
[SOUR] VOLT PROT DEL.....	246
[SOUR] VOLT PROT REM [POS].....	248
[SOUR] VOLT PROT REM NEG.....	250
[SOUR] VOLT PROT TRAC.....	252
[SOUR] VOLT PROT TRAC OFFS.....	254
[SOUR] VOLT RANG.....	256
[SOUR] VOLT SLEW.....	258
[SOUR] VOLT SLEW MAX.....	260
[SOUR] VOLT TRIG.....	235
standard event status group.....	262
status byte.....	263
status commands	
STAT OPER COND?.....	267
STAT OPER ENAB.....	269
STAT OPER NTR.....	271
STAT OPER PTR.....	273
STAT OPER?.....	265
STAT PRES.....	275
STAT QUES COND?.....	278

Index

STAT QUES ENAB	280
STAT QUES NTR	282
STAT QUES PTR	284
STAT QUES?	276
subsystem commands.....	17
suffixes	15
system commands	
SYST CHAN MOD?	287, 288
SYST CHAN OPT?	289
SYST CHAN SER?	290
SYST COMM RLST	291
SYST COMM TCP CONT.....	292
SYST ERR?.....	293
SYST GRO CAT?	294
SYST GRO DEF.....	295
SYST GRO DEL.....	296
SYST GRO DEL ALL	297
SYST PASS FPAN RES.....	298
SYST REB	299
SYST VERS?	300

T

trigger commands	
TRIG ACQ.....	302
TRIG ACQ CURR	303
TRIG ACQ CURR SLOP	305
TRIG ACQ SOUR	307
TRIG ACQ TOUT.....	309
TRIG ACQ VOLT	311
TRIG ACQ VOLT SLOP	313
TRIG ELOG	315
TRIG ELOG SOUR	316
TRIG TRAN	317
TRIG TRAN SOUR.....	318
types of SCPI commands	10

V

voltage	
measurement range.....	175

W

Web server.....	6
Web URL's	6, 7