

R&S® SMW200A VECTOR SIGNAL GENERATOR



The fine art of signal generation



Product Brochure
Version 06.00

ROHDE & SCHWARZ

Make ideas real



AT A GLANCE

The R&S®SMW200A is the vector signal generator for the most demanding applications. As a result of its flexibility, performance and intuitive operation, it is a perfect tool for generating complex, digitally modulated signals of high quality.

The R&S®SMW200A is the ideal generator for digitally modulated signals required for the development of new wideband communications systems, the verification of 4G and 5G base stations or in the aerospace and defense sector.

The I/Q modulation bandwidth of up to 2 GHz with internal baseband satisfies fourth and fifth generation standards (e.g. 5G, LTE-Advanced and IEEE 802.11ac/ad), and the R&S®SMW200A is designed to meet future requirements. Its modular scalable architecture allows users to optimize the generator to their applications and to upgrade it as required.

A second RF path can be added, as well as a maximum of two baseband and four fading simulator modules – without compromising signal quality. As a result, the R&S®SMW200A can create signal scenarios that previously required multiple instruments or could not be implemented at all. From MIMO up to 8x8 and LTE-Advanced carrier aggregation including fading to multistandard radio – never before has an instrument offered such high class signal generation capability.

If more than two RF paths are required, additional R&S®SGMA signal generator modules can be connected. The intuitive, touchscreen based operating concept provides the user with an overview of measurements, no matter how complex, and quickly delivers the desired results.

KEY FACTS

- ▶ Frequency range from 100 kHz to 3 GHz, 6 GHz, 7.5 GHz, 12.75 GHz, 20 GHz, 31.8 GHz, 40 GHz or 44 GHz
- ▶ Optional second RF path with 100 kHz up to 3 GHz, 6 GHz, 7.5 GHz, 12.75 GHz, 20 GHz, 31.8 GHz or 44 GHz
- ▶ Up to 2 GHz I/Q modulation bandwidth (in RF) with internal baseband
- ▶ Options for all important digital communications standards
- ▶ Optional integrated fading simulator with up to 800 MHz bandwidth
- ▶ Support of all key MIMO modes including 3x3, 4x4, 8x4, 4x8 and 4x2x2
- ▶ Intuitive operation via touchscreen with block diagram as key element

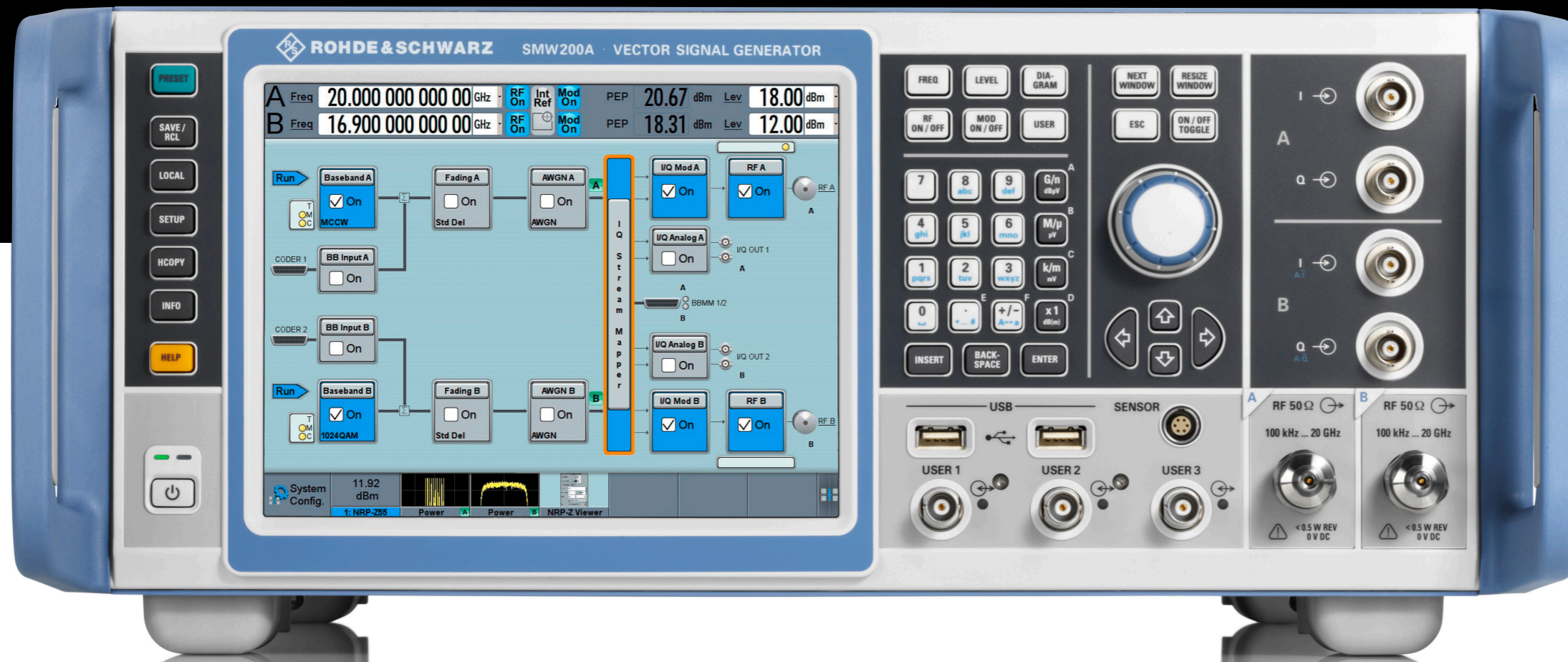

BENEFITS AND KEY FEATURES

For all your needs

- ▶ Frequency range from 100 kHz to 3 GHz, 6 GHz, 7.5 GHz, 12.75 GHz, 20 GHz, 31.8 GHz, 40 GHz or 44 GHz
 - ▶ Optional second RF path with 100 kHz up to 3 GHz, 6 GHz, 7.5 GHz, 12.75 GHz, 20 GHz, 31.8 GHz or 44 GHz
 - ▶ Versatile configuration: from single-path vector signal generator to multichannel MIMO receiver tester
 - ▶ Ideal for MIMO, MSR or LTE-Advanced applications thanks to up to eight signal sources and up to 64 fading channels
 - ▶ Modular architecture for optimal adaptation to the application at hand
- ▶ [page 6](#)

Simplify your setup

- ▶ Wideband baseband and vector signal generator in one box
 - ▶ Easy generation of complex signals
 - ▶ Max. eight baseband generators on two internal baseband modules with realtime coder and ARB
 - ▶ Internal digital adding of baseband signals, even with frequency and level offset
 - ▶ Support of all important digital standards such as 5G New Radio, LTE (up to Release 15), NB-IoT, eMTC, 3GPP FDD/HSPA/HSPA+, GSM/EDGE/EDGE Evolution, WLAN IEEE802.11a/b/g/n/l/p/ac/ax/ad
 - ▶ No separate PC software required for digital standards
 - ▶ Generation of radar signal scenarios for module, receiver and DFS tests
 - ▶ 5G NR, LTE and 3GPP test case wizards for easy base station conformance testing in line with 3GPP TS38.141, 3GPP TS36.141 or 3GPP TS25.141
 - ▶ Envelope tracking and AM/AM, AM/φM predistortion options for full testing and verification of ET modulator chipsets
- ▶ [page 8](#)

Bring reality to your lab

- ▶ Optional integrated fading section for channel emulation with up to 800 MHz bandwidth
 - ▶ All important fading scenarios available as presets
 - ▶ Installation of up to four fading modules, providing as many as 64 "logical" faders
 - ▶ Implementation of all key MIMO fading scenarios such as 2x2, 3x3, 4x4, 8x4 and 4x8 using a single instrument
 - ▶ Support of complex applications such as dual-carrier HSPA, LTE carrier aggregation with MIMO and multi-user LTE
 - ▶ Connection of R&S®SGT100A signal generator modules to provide up to eight RF paths
- ▶ [page 12](#)

Make your device even better

- ▶ Excellent signal quality for high accuracy in spectral and modulation measurements
 - ▶ Up to 2 GHz I/Q modulation bandwidth (in RF) with internal baseband
 - ▶ Exceptional modulation frequency response of < 0.4 dB (meas.) over 2 GHz bandwidth
 - ▶ High-end pulse modulation with on/off ratio > 80 dB and rise/fall time < 10 ns
 - ▶ Excellent spectral purity (SSB phase noise -150 dBc (typ.) at 1 GHz, 10 kHz offset)
 - ▶ Phase coherence option, e.g. for beamforming applications
 - ▶ 3 GHz, 6 GHz, 7.5 GHz and 12.75 GHz RF paths with electronic attenuator
- ▶ [page 14](#)

Speed up your development

- ▶ Intuitive operating concept and clever help functions for quick success
 - ▶ Block diagram as key operating element to visualize signal flow
 - ▶ Adaptive GUI for overview of both simple and complex scenarios
 - ▶ Graphical signal monitoring at practically every point in the signal flow
 - ▶ Context-sensitive online help system with complete user documentation
 - ▶ SCPI macro recorder and code generator for generating executable remote control code from manual operating steps (for MATLAB®, CVI, etc.)
- ▶ [page 18](#)

Grows with your needs

- ▶ Customizing of instrument to accommodate virtually every application
 - ▶ Advanced plug-in system for retrofitting baseband modules without instrument recalibration
 - ▶ Software upgrades possible at any time, simple and quick activation via key codes
- ▶ [page 20](#)

Development of new wideband communications systems with the R&S®SMW200A

The R&S®SMW200A is the ideal signal generator for developing new wideband communications systems. It flexibly generates 5G NR signals.

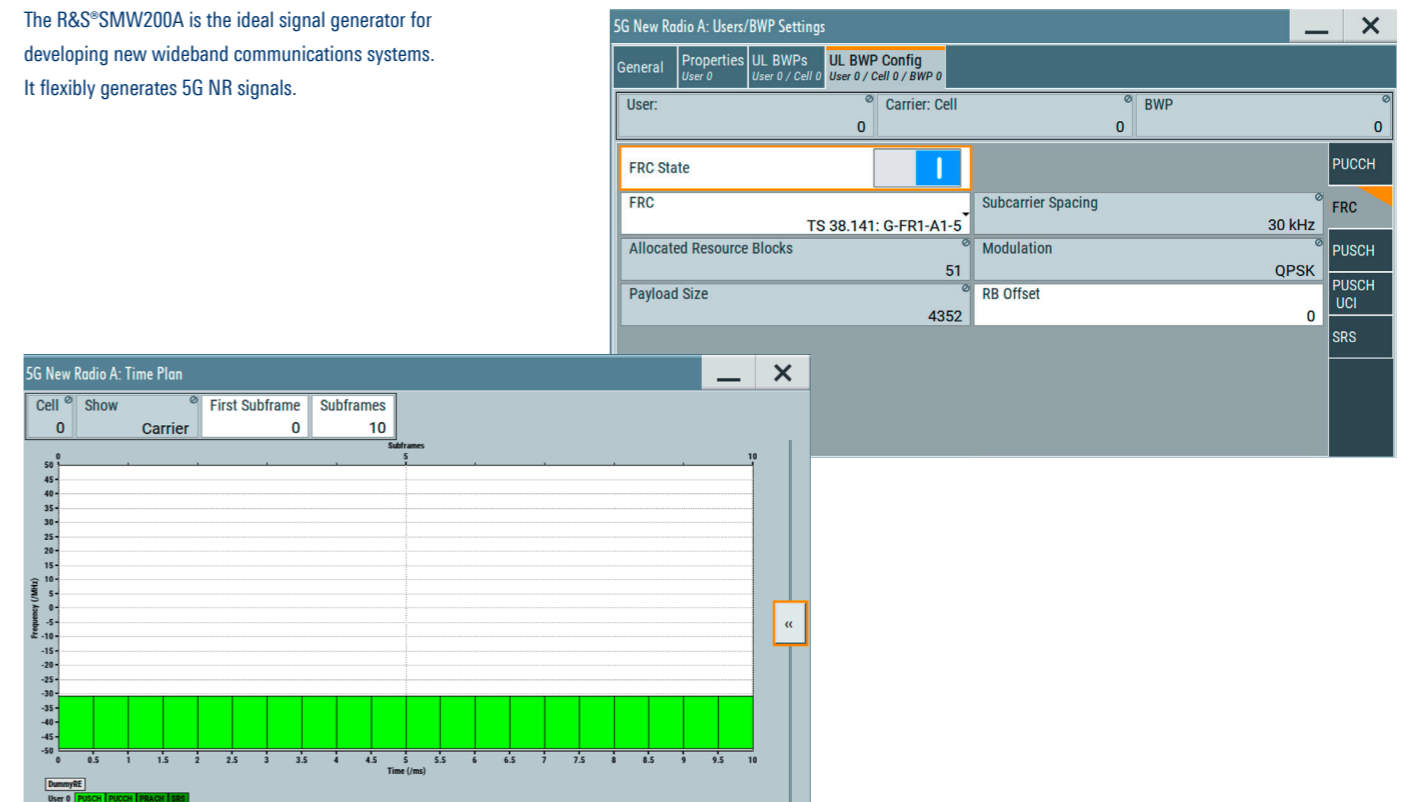

FOR ALL YOUR NEEDS

Advanced RF measuring equipment must, above all, be flexible. Performance and functionality requirements vary depending on test setup and application. The R&S®SMW200A is unrivaled in mastering this challenge and sets new standards for signal generators. In development and verification, for any type of DUT (components, modules, complete base stations) – the R&S®SMW200A always generates the appropriate test signals.

Versatile configuration

Thanks to its modular design, the R&S®SMW200A can be equipped with the exact options required for a specific application. Any configuration is possible, from a classic single-path vector signal generator to a multichannel MIMO receiver tester.

The generator can be equipped with a maximum of two internal baseband modules and four fading simulator modules. It is also possible to install a second RF path. This concept yields two full-featured vector signal generators in a single unit, so that even complex signal scenarios (e.g. wanted signal + interferer, dual cell, TX/RX diversity) can be created easily.

R&S®SMW200A vector signal generator with two R&S®SGMA signal generator modules on top

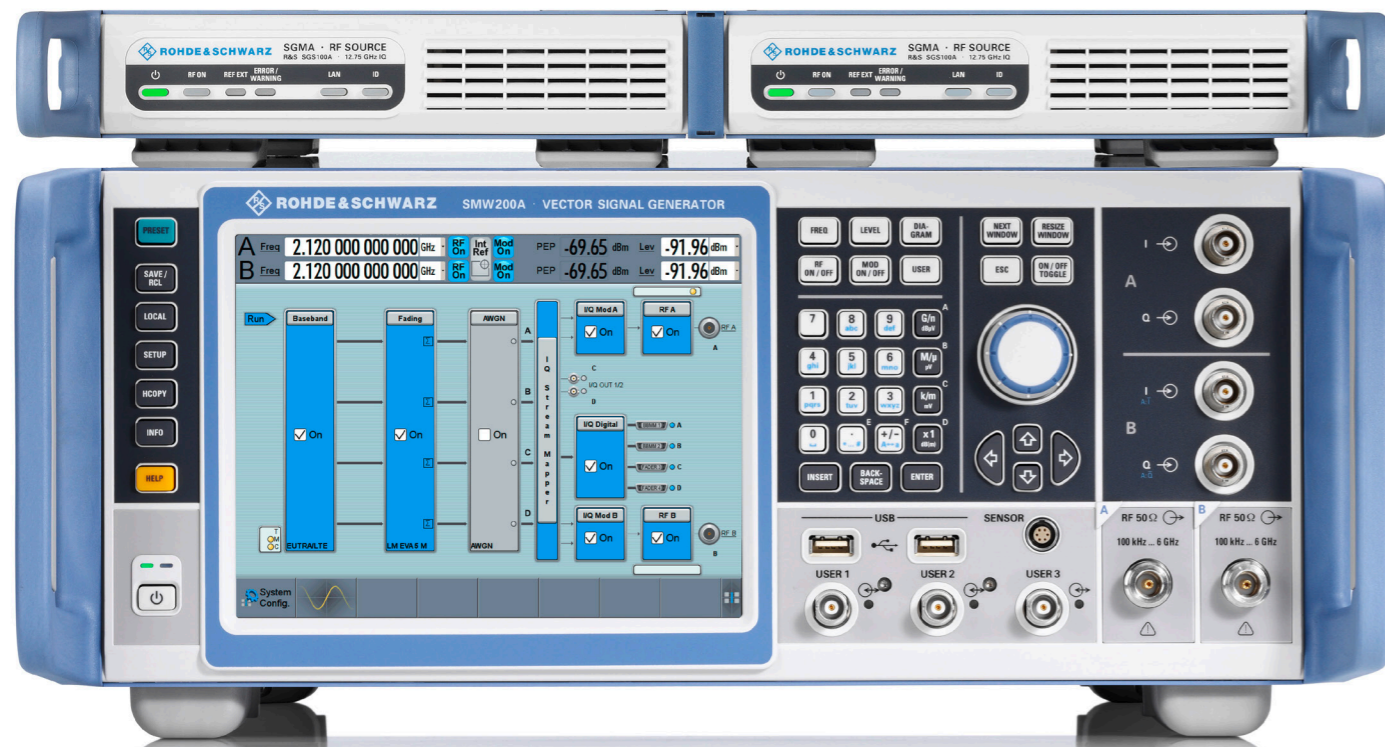

Ideal for MIMO, MSR or LTE-Advanced applications

And that is by far not all. The capabilities of the R&S®SMW200A surpass those of two conventional generators combined. When the instrument is fully equipped, the baseband section provides up to eight independent signal sources and up to 64 logical faders. This makes the R&S®SMW200A ideal for MIMO and other complex applications encountered in LTE-Advanced (carrier aggregation), HSPA (dual carrier) and multistandard radio, etc.

Modular architecture for optimal adaptation to the application at hand

Almost all options of the R&S®SMW200A can be retrofitted, most of them simply via key code. Starting from the basic configuration as a classic single-path vector signal generator, the R&S®SMW200A can be customized as required for any application. Users only have to purchase what they currently need and are free to decide on upgrades according to their future requirements.

Basic R&S®SMW200A architecture

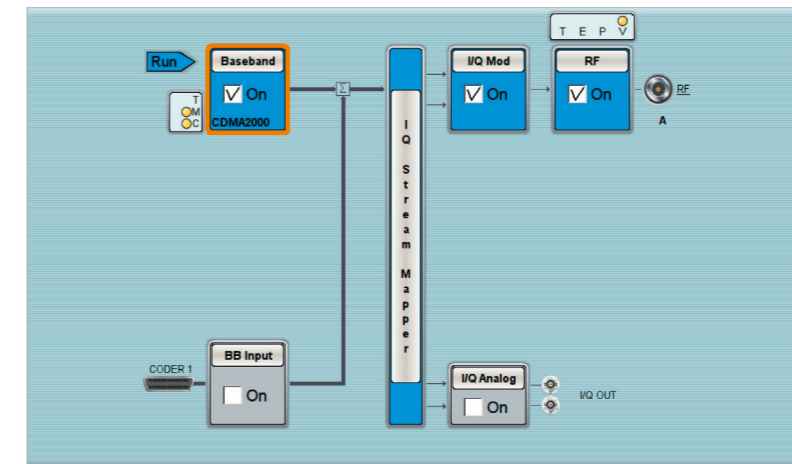

Configuration example 1:

A single-path R&S®SMW200A with internal baseband can be used for measurements on components or for fundamental receiver testing.

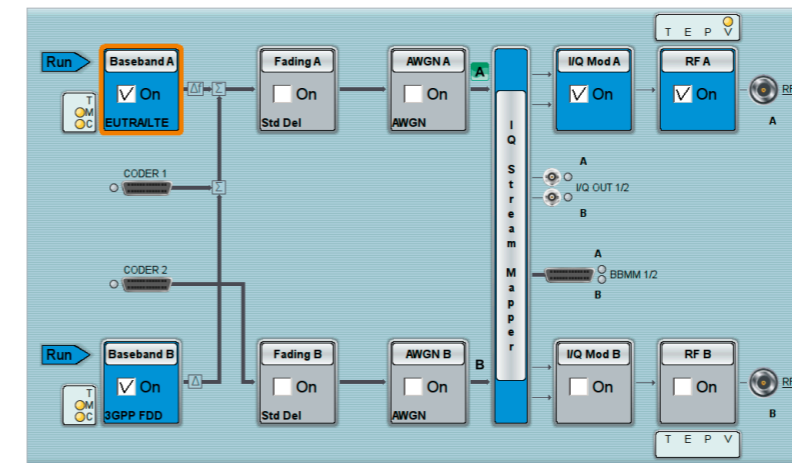

Configuration example 2:

A two-path R&S®SMW200A is ideal for receiver and performance tests on base stations. One generator can generate the wanted signal plus interferer (in this example, a wanted LTE signal and a 3GPP FDD interferer).

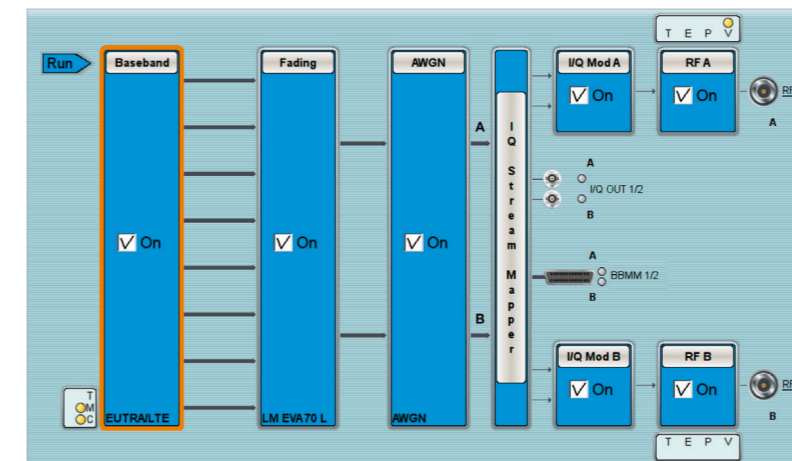

Configuration example 3:

A fully equipped R&S®SMW200A with MIMO option covers all key MIMO scenarios, such as 8x2 shown in the screenshot. In this case, the baseband section provides eight signal sources and 32 "logical" faders, i.e. MIMO channels.

SIMPLIFY YOUR SETUP

Wideband baseband and vector signal generator in one box

A vector signal generator needs a powerful baseband section to meet the requirements of advanced communications systems. The R&S®SMW200A sets standards in this field too. It can be equipped with a baseband section that provides up to 2 GHz internal RF modulation bandwidth. This option makes the R&S®SMW200A the first vector signal generator to offer a fully calibrated wideband solution up to 44 GHz in a single device.

One or two baseband generators can be installed in a single instrument, which makes it possible to generate two independent wideband signals up to 44 GHz with any type of modulation using just one instrument.

Each of the two available baseband modules contains a realtime coder and an arbitrary waveform generator with max. 2 Gsample memory depth. The bandwidth of up to 2 GHz covers modern digital standards, such as 5G NR, LTE and WLAN IEEE802.11ac, as well as wideband multicarrier or multistandard radio signals.

Easy generation of complex signals

The baseband signals can be digitally added, provided with a frequency offset of max. ± 1 GHz and varied in power and phase relative to each other. This makes it incredibly simple to generate multicarrier scenarios and combinations of different digital standards with the R&S®SMW200A.

A single two-path R&S®SMW200A is all that is needed to create the wanted signal plus interferer scenarios often required in receiver testing. Depending on the scenario's overall bandwidth and the desired level difference between wanted signal and interferer, the signals can in many cases be output by using only one RF path. The second RF path is available for other tasks, e.g. generation of an additional CW interferer.

Advanced multichannel signal generation

The R&S®SMW200A generator's advanced baseband architecture enables it to simulate even complex scenarios. Up to eight internal baseband sources make it easy to generate multiple signals required, for example, for LTE carrier aggregation, multicell/multi-user simulation, interference testing or multistandard radio (MSR) tests. Optional fading and noise simulation for each of the eight individual channels is also possible.

Flexible routing capabilities and internal realtime addition of the baseband signals allow a parallelized testing approach. All signals are generated with their own periodicity. This allows the simultaneous generation of multiple carriers with nontruncated data sequences and enables a DUT to perform demodulation tests for each of the signals at the same time. As a result, the overall test time is reduced and only a minimum of hardware investment is needed.

Ready for future technologies: 5G and IEEE 802.11ad

The R&S®SMW200A is the ideal tool for every engineer who develops components, devices or infrastructure for the next generation of mobile communications. 5G New Radio signals are directly created on the instrument, helping users to efficiently master their design challenges. Typical test scenarios such as co-existence tests with LTE or wideband 5G signal generation in the microwave range are covered by a single instrument. WLAN IEEE802.11ad signals with a symbol rate of 1.76 Gsample/s in single carrier mode are supported as well. Due to its intelligent internal modulation frequency response compensation, the R&S®SMW200A also excels in I/Q flatness and modulation quality for all wideband signals.

Two-path R&S®SMW200A

In a two-path R&S®SMW200A, baseband signals can be digitally added and provided with baseband frequency offset. This makes it possible to easily generate multicarrier scenarios or wanted signal plus interferer scenarios.

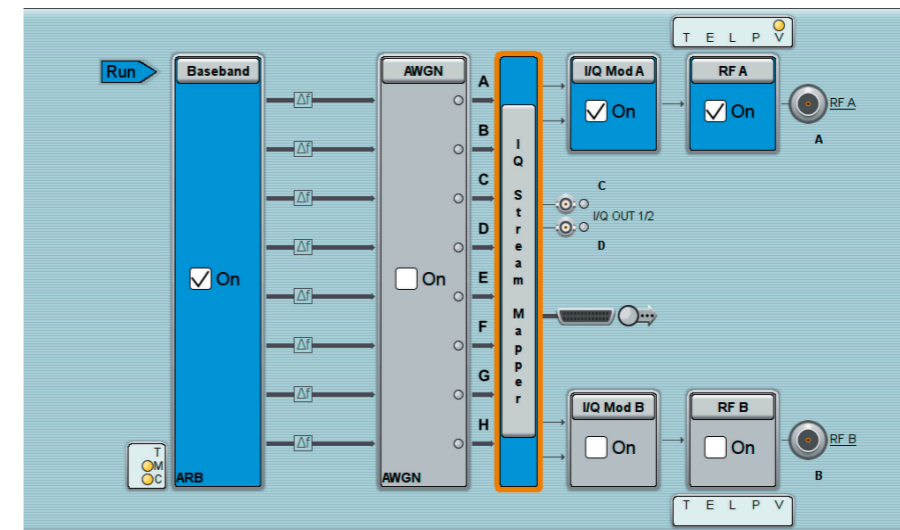
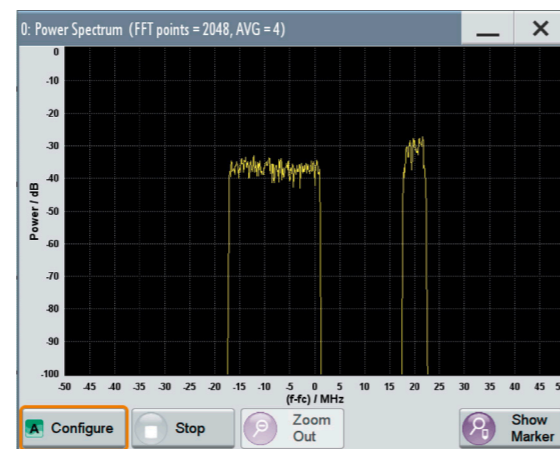
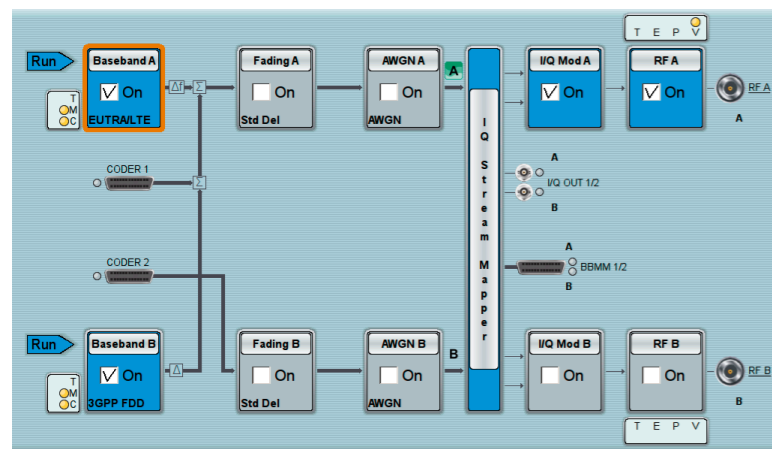

The R&S®SMW200A is the ideal generator for multistandard radio and interference tests. In this example, it is generating eight different frequency-spaced signals that are added up in realtime for receiver testing.

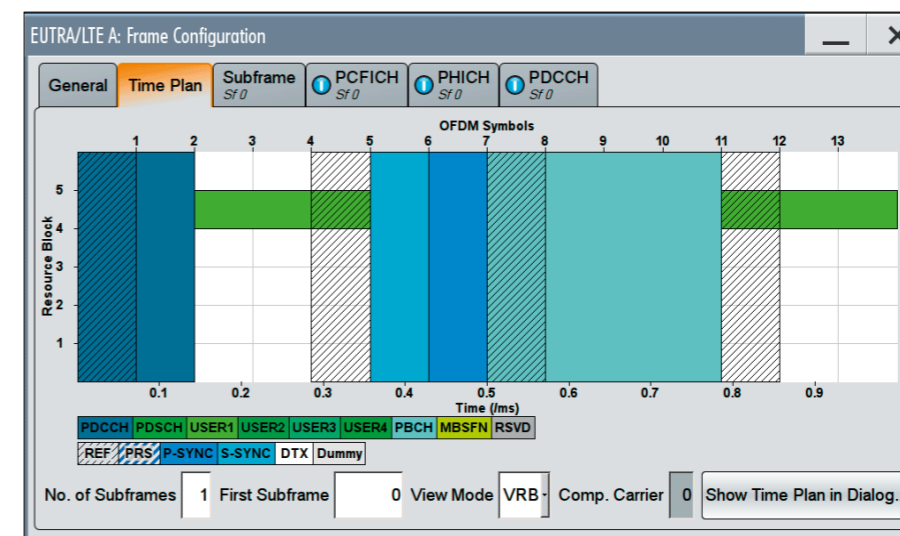

Time plan display in the LTE option of the R&S®SMW200A.

Support of all important digital standards

The R&S®SMW200A uses software options to generate signals for all important digital standards, particularly 5G NR, LTE/LTE-Advanced (up to Release 15), 3GPP FDD/HSPA/HSPA+, GSM/EDGE/EDGE Evolution and WLAN IEEE802.11a/b/g/n/j/p/ac/ax/ad. The entire physical layer is simulated, as well as channel coding for the majority of standards. As a result, the R&S®SMW200A is perfect for standard-compliant receiver measurements, e.g. tests on base stations in line with 3GPP TS38.141 (for 5G NR) or 3GPP TS36.141 (for LTE/LTE-Advanced).

In contrast to many other solutions on the market, the signals for the digital standards can be configured and generated directly on the R&S®SMW200A. Because the software options integrate seamlessly into the instrument's firmware, there is no need for additional PC software. This simplifies operation and also saves valuable testing time, since no time-consuming waveform transfer from the external PC software to the signal generator's output memory has to be performed.

As a result of its outstanding performance, the R&S®SMW200A responds virtually without delay to new settings, even when they require comprehensive signal calculations. Therefore, test scenarios can easily and quickly be adapted to new requirements. Parameters can be varied with immediate effect for optimization or troubleshooting, without causing unproductive interruptions or waiting time.

Users benefit from numerous help functions. Predefined settings can be used to configure standard-compliant signals (e.g. test models defined in the standard) at the

press of a button. Visual aids such as the time plan in the LTE option provide a graphical overview of the signal structure. They help users keep track of even complex signal scenarios and quickly set the desired parameters. The test case wizards for complex digital standards such as 5G NR, LTE and 3GPP FDD (UMTS) are powerful tools that simplify the user's task. It only takes a few steps to configure the R&S®SMW200A for base station tests in line with 3GPP TS38.141, 3GPP TS36.141 or 3GPP TS25.141.

Generating signals for radar module and receiver tests

Together with the R&S®Pulse Sequencer software the R&S®SMW200A generates simple pulses, pulse trains as well as complex multi-emitter and multichannel radar scenarios. For each individual pulse, the pulse timing and the intrapulse modulation such as AM/FM, wideband chirp, Barker or polyphase can flexibly be configured. Control elements such as nested loops, overlays and subsequences allow dynamic sequencing applications. Deterministic or random interpulse modulation profiles enable the user to configure time-varying pulse train characteristics with minimum effort.

Antenna diagrams and antenna scans can be added to the defined pulse sequences to simulate realistic radar emitters. For scenario simulation, multiple emitters and a receiver can be placed on a 2D map, including attitude and height information. Using an additionally configured receiver antenna diagram and antenna scan, the R&S®SMW200A creates real-world signals as they occur at the RF output of a receiver antenna. This allows inexpensive conducted receiver tests in the lab instead of costly over-the-air field tests. The emulated receiver can even be configured to carry multiple antennas, each with individual

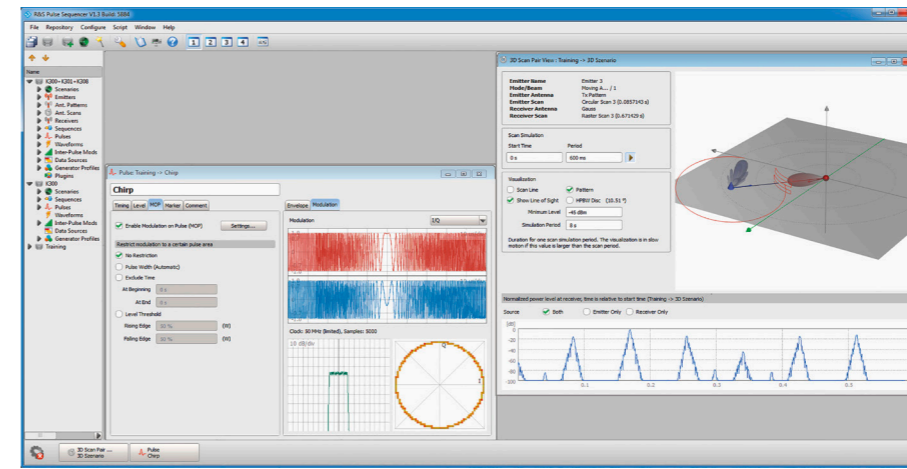

R&S®Pulse Sequencer software for creating radar signals and scenarios with the R&S®SMW200A.

antenna pattern, position and pointing direction. This turns the R&S®SMW200A into a powerful platform for testing radar modules as well as multichannel receivers in direction finding applications.

Furthermore, the R&S®SMW200A together with the R&S®Pulse Sequencer software can create radar signals as specified by FCC, ETSI or the TELEC T403 standard for dynamic frequency selection (DFS) tests. This makes the R&S®SMW200A the ideal solution for testing WLAN devices for correct behavior in the presence of a radar signal in the same frequency band.

Efficient testing of amplifiers with envelope tracking

The objective of envelope tracking (ET) is to reduce power consumption and the amplifier's overall energy consumption. Instead of receiving a constant supply voltage, the amplifier is fed a voltage from a DC modulator. This

voltage tracks the envelope of the RF signal. Extremely precise synchronization is crucial since even deviations in the nanosecond range would cause significant modulation errors (EVM).

The R&S®SMW200A offers options that allow users to very easily generate the right envelope signal for an RF signal in realtime and output it at the analog I/Q output. Since both signals come from the same instrument, users do not need to worry about synchronization. The delay between the RF signal and the envelope signal relative to each other can be set in realtime with a 1 ps resolution in order to compensate for different delays in the test setup. The digital predistortion option enables AM/AM and AM/φM predistortion of the signals in realtime. This flexibility and its outstanding signal performance make the R&S®SMW200A the perfect signal source for precise and efficient ET measurements.

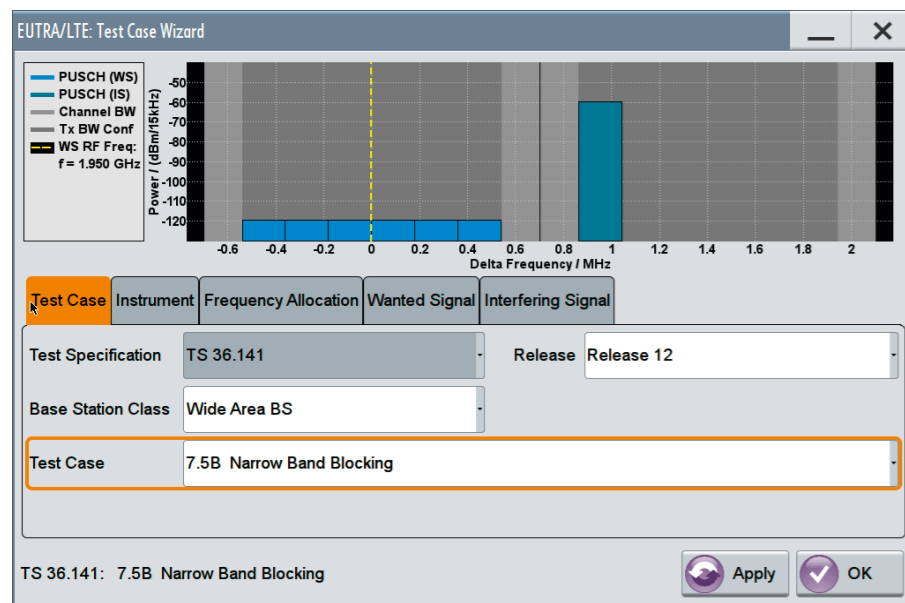

The LTE test case wizard allows the R&S®SMW200A to be conveniently and cleverly configured for BTS tests in line with 3GPP TS36.141. In this example, wanted signal and interferer for a narrowband blocking test are set.

Test setup for envelope tracking with the R&S®SMW200A and the R&S®FSW

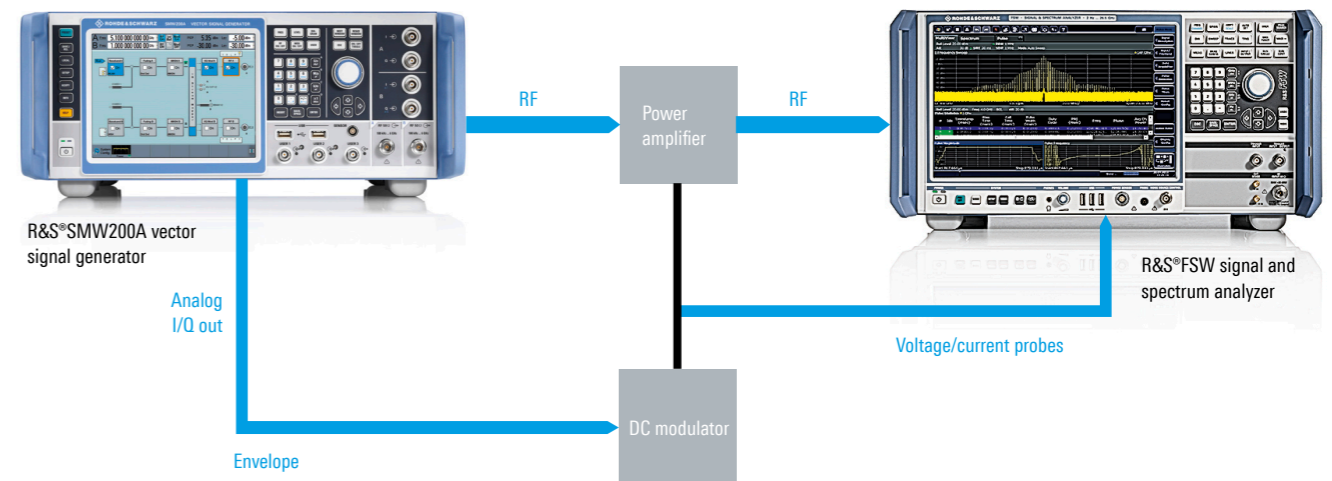

BRING REALITY TO YOUR LAB

Advanced, state-of-the-art channel emulation

The internal fading simulator option is another element that distinguishes the R&S®SMW200A from other RF vector signal generators. Using latest FPGA technology the hardware was designed for exceptional compactness so that up to four of the powerful fading modules can be installed. These modules can simultaneously emulate as many as 64 fading channels. The maximum fading bandwidth is 800 MHz. As a result, the R&S®SMW200A can realistically map even MIMO scenarios such as 3x3 MIMO for WLAN IEEE 802.11.

Inside buildings, there are more reflections than in open terrain. The time difference between different echoes normally is in the range of only a few nanoseconds. Its time resolution of 2 ps and its ability to simulate up to 20 paths

per fading channel enable the R&S®SMW200A to realistically simulate indoor fading scenarios. All in all, the R&S®SMW200A offers a fading performance that has so far only been achieved by significantly more expensive special instruments (e.g. RF faders).

The user can select the fading scenarios required for all major standards directly from the predefined settings. In addition to classic multipath scenarios with Rayleigh, Rice or pure Doppler fading, the R&S®SMW200A can also simulate the dynamic scenarios specified in recent standards, such as birth-death, moving propagation and high-speed train. Profiles for car-to-car communications are supported as well. All parameters can also be set manually, which makes it easy to implement user-specific fading configurations.

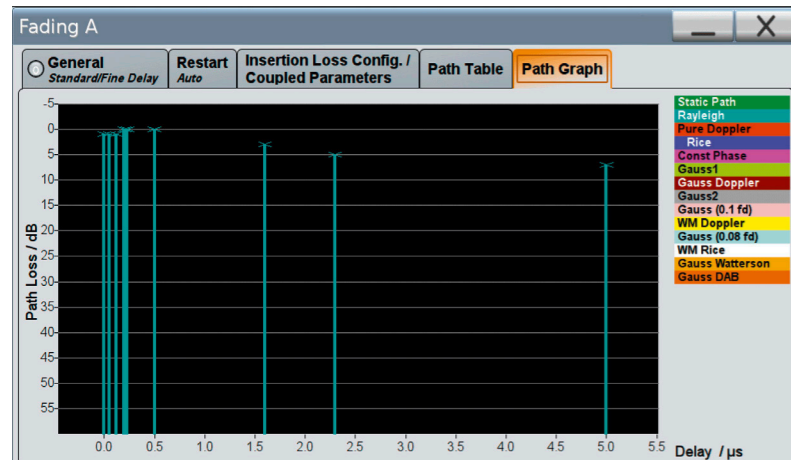

The fading settings of the R&S®SMW200A can be visualized to support the user. The screenshot shows the fading path configuration of an LTE ETU300 scenario.

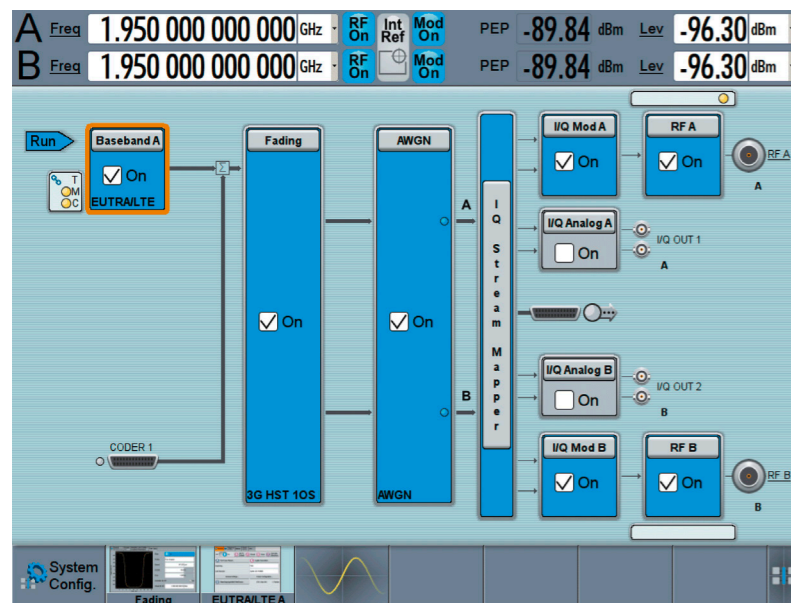

The R&S®SMW200A is perfect for LTE base station performance tests in line with 3GPP TS36.141. In this example, the block diagram (screenshot on the left) and fading settings (screenshot below) for testing with high-speed train fading are shown.

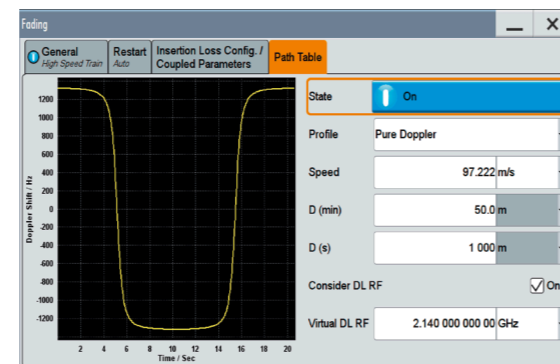

Prestigious discipline: MIMO

All modern wireless communications standards utilize MIMO technology to increase the effective data throughput. A test generator must be able to simulate MIMO scenarios exactly as they are present at the receive antennas of a receiver – even with complex MIMO receivers. This is where the multipath and fading capabilities of the R&S®SMW200A come into their own. The built-in baseband modules allow the simultaneous generation of up to eight signals. For MIMO scenarios, the signals from all transmit antennas – with antenna-specific coding – can be directly generated in a single instrument.

In addition, the R&S®SMW200A is able to simulate the entire MIMO channel. Up to 64 logical faders cover all key MIMO scenarios such as 3x3, 4x4, 8x4 and 4x8. The user can also set the correlations between the propagation paths. Multistandard setups, such as simultaneous 2x2 MIMO for LTE and 3GPP FDD HSPA, are possible as well. Furthermore, carrier aggregation scenarios with four LTE component carriers (each with 2x2 MIMO) can be simulated with a single instrument. No matter how complicated the application – the R&S®SMW200A handles unique stimulus generation and channel simulation in parallel.

The R&S®SMW200A can be equipped with one or two internal RF paths. If necessary, more RF paths can be added: Two additional I/Q-modulated R&S®SGT100A signal generator modules turn the R&S®SMW200A into an extremely compact 4x4 MIMO complete solution. Adding another four R&S®SGT100A modules enhances the solution to cover even 4x8 or 2x4x4 MIMO scenarios. The additional hardware is operated and remotely controlled directly from the R&S®SMW200A.

The R&S®SMW200A easily handles even complex MIMO setups. The global system configuration dialog can be used to reconfigure the signal generator according to the

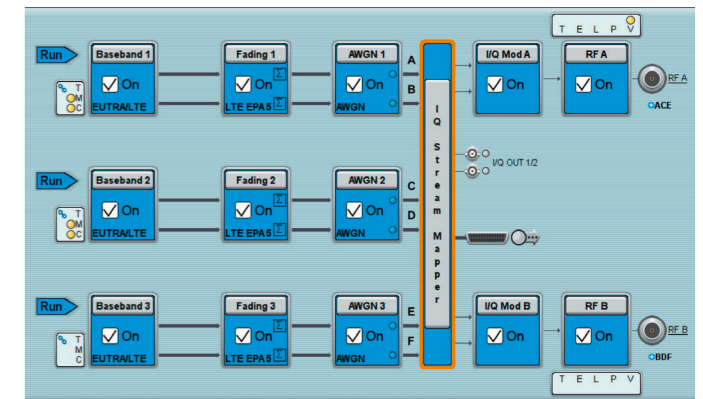

Block diagram of the R&S®SMW200A configured for the generation of an LTE Release 11 fciCIC test scenario. One R&S®SMW200A simultaneously generates the LTE serving cell as well as the two aggressor cells, each with 2x2 MIMO, with correlated fading channels.

required signal scenario. The block diagram on the GUI changes with the application so that the user can see at a glance which signal scenario is being generated. Every system configuration is accompanied by typical application examples. Users who “think beyond the standard” will also easily find an optimal scenario for their needs.

In the case of MIMO-capable standards such as 5G NR, LTE or WLAN, the transmit signals depend on each other. Therefore, the R&S®SMW200A features a shared menu (coupled sources mode) with which multi-antenna signals can be configured quickly and conveniently.

As an alternative, the signals can be set individually in the R&S®SMW200A (separate sources mode). This mode allows the simultaneous generation of signals for different standards, which makes the R&S®SMW200A ideal for testing multistandard base stations. Combinations (e.g. LTE, WCDMA and GSM) are possible as well as the use of user-defined ARB signals.

4x8 MIMO setup

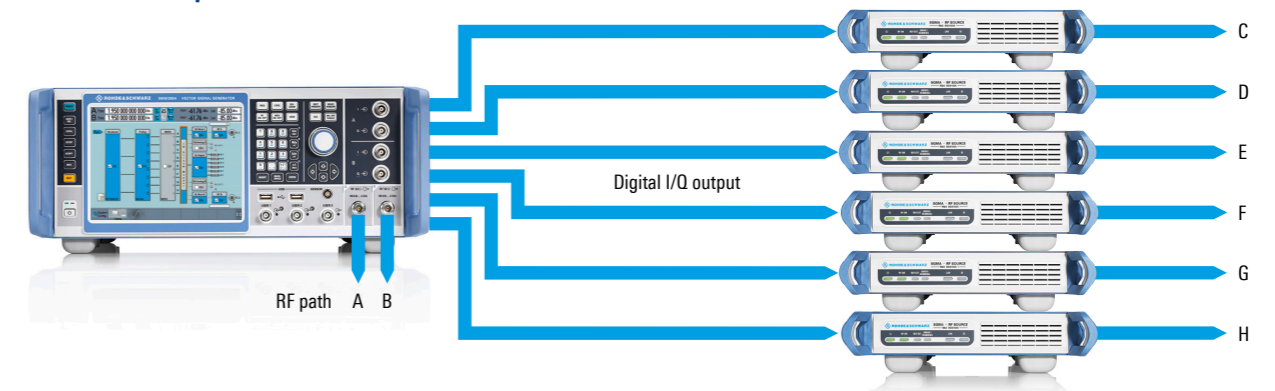

4x8 MIMO setup, consisting of a two-path R&S®SMW200A and six R&S®SGT100A signal generator modules operated from the R&S®SMW200A. The modules provide RF paths 3 to 8. The R&S®SMW200A fully performs baseband signal generation and fading.

MAKE YOUR DEVICE EVEN BETTER

Excellent signal quality

Testing high performance DUTs requires a signal generator solution that features significantly better RF characteristics than the DUT itself. Otherwise, the measurement results might be falsified by the signal generator. The R&S®SMW200A fully meets this requirement, enabling the DUT's entire potential to be utilized.

Exceptional modulation characteristics

The R&S®SMW200A features a wideband I/Q modulator with up to 2 GHz RF bandwidth. With this bandwidth, it covers practically all applications in its frequency range, including wireless and satellite communications, radar, research and education. The internal baseband makes it

possible to generate signals with a maximum width of 2 GHz.

State-of-the-art D/A converters and an excellent RF chain ensure exceptional modulation characteristics. All in all, a modulation frequency response of < 0.4 dB (meas.) over 2 GHz bandwidth can be achieved. The R&S®SMW200A generates 5G NR signals (100 MHz channel bandwidth, 64QAM PDSCH, 39 GHz carrier frequency) with an EVM of -43 dB (meas.). Other signal types such as WCDMA, LTE, wideband QAM-modulated carriers or chirped pulses as well as multicarrier CW scenarios can also be output with highest quality.

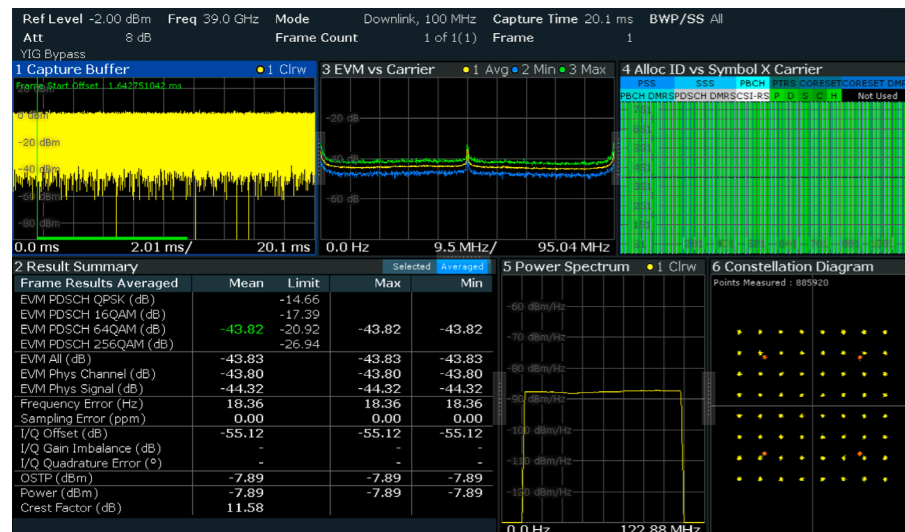

Measured EVM of a 5G NR signal (100 MHz channel bandwidth, 64QAM PDSCH, 39 GHz carrier frequency).

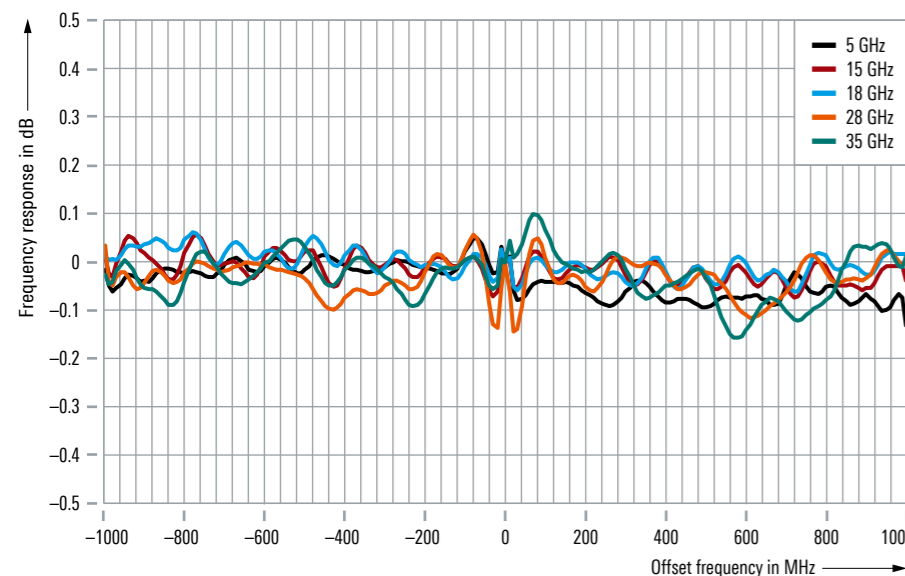

Measured I/Q modulation frequency response with internal wideband baseband

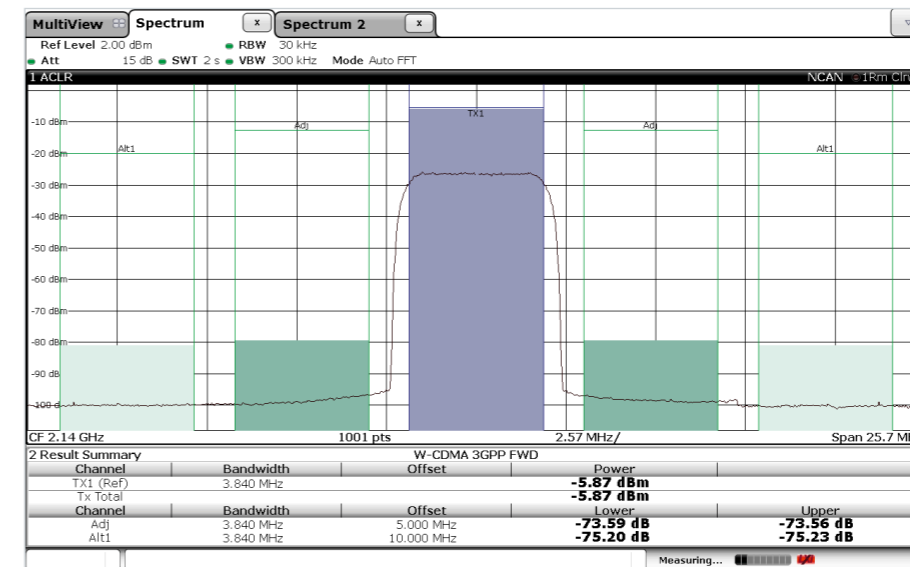

Measured ACPR for 3GPP test model 1, 64 DPCH.

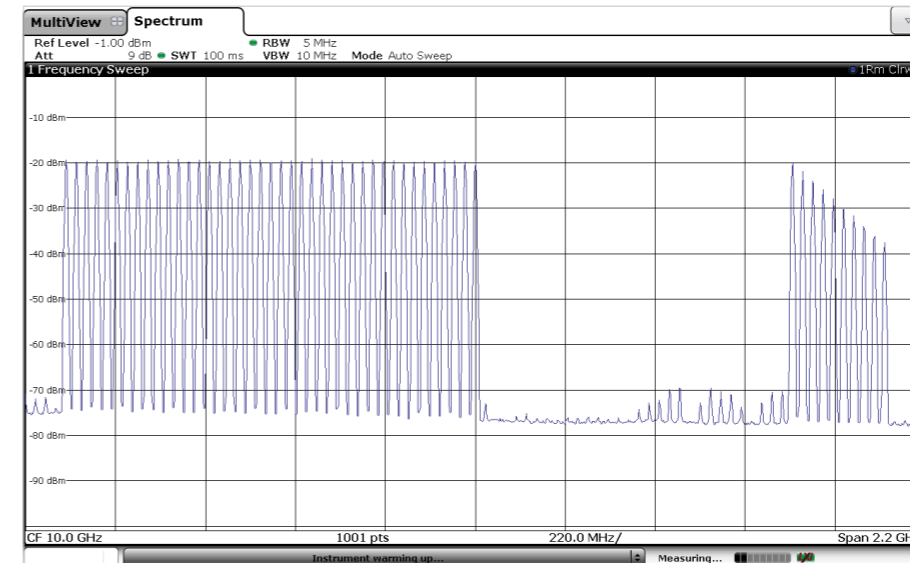

The R&S®SMW200A generates top-quality wideband signals, including signals that are asymmetrical to the center frequency. In this example, at 10 GHz a 2 GHz wide multicarrier CW scenario with 41 equal-power carriers is generated on the left and 10 carriers with graduated power on the right.

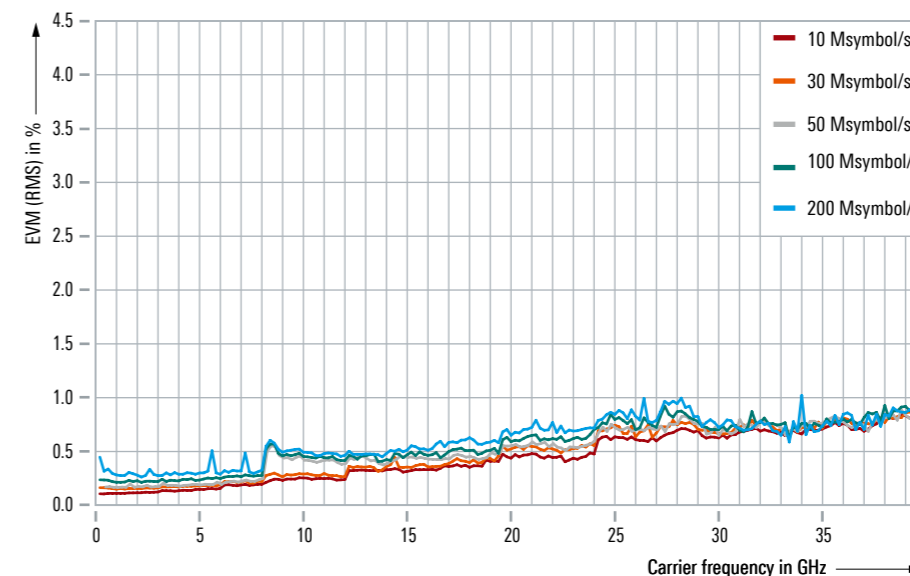

Measured EVM versus carrier frequency for 16QAM

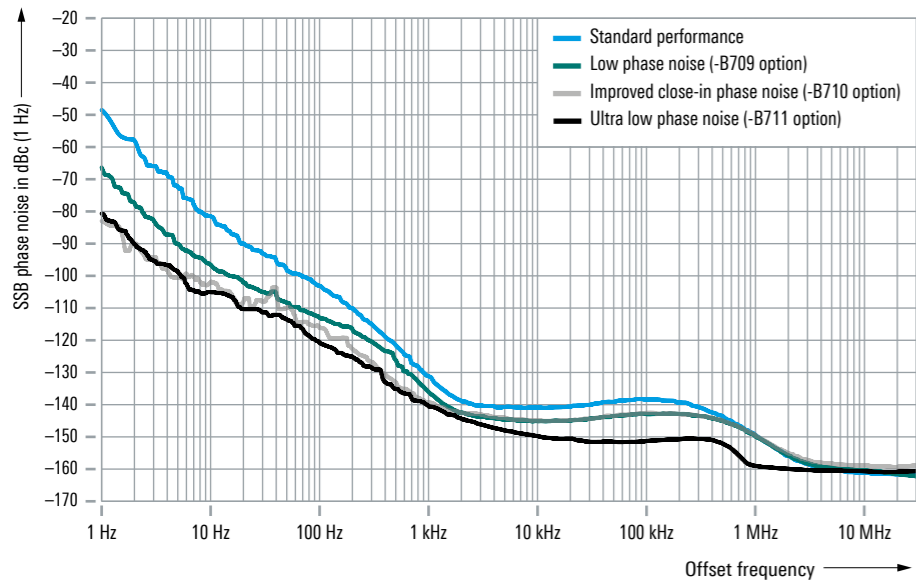

Measured SSB phase noise performance at $f = 1$ GHz, CW mode, standard performance versus the R&S®SMW-B709, R&S®SMW-B710 and R&S®SMW-B711 options

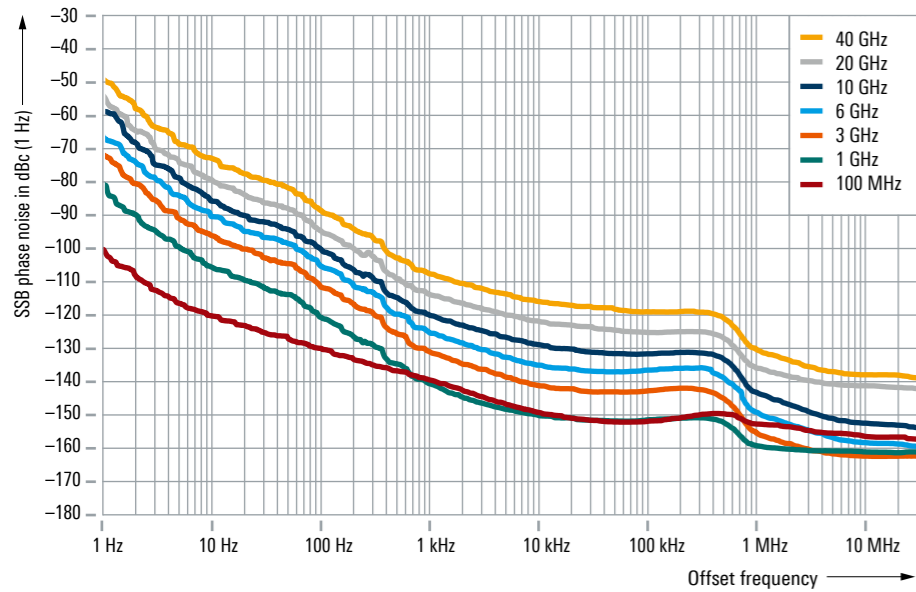

Measured SSB phase noise performance, with R&S®SMW-B711/-B721 options, CW mode

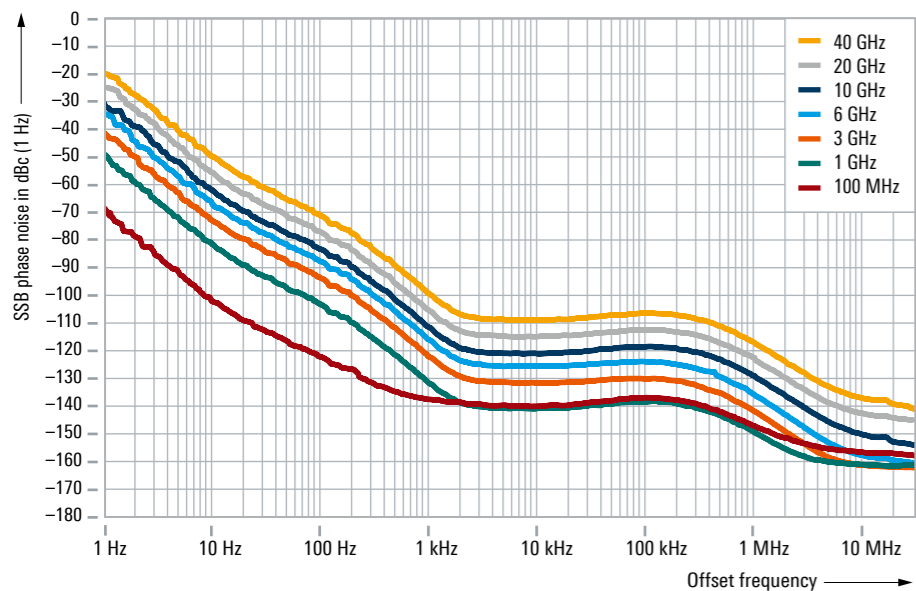

Measured SSB phase noise performance, standard instrument, CW mode

Very good RF characteristics

The RF characteristics of the R&S®SMW200A are simply impressive. The absolute level accuracy is better than 0.5 dB ($f \leq 3$ GHz) across the entire specified level range from -120 dBm to +18 dBm, without additional options being required. Frequency and level setting times of 600 μ s (typ.) via IEC/IEEE bus make the R&S®SMW200A the fastest high-end vector signal generator on the market and help save valuable time. Thanks to its excellent pulse modulator with on/off ratio > 80 dB and rise/fall time < 10 ns, the R&S®SMW200A is ideal for generating pulsed signals for radar applications.

The high-end synthesizer, which is included in the standard version of the R&S®SMW200A, already delivers exceptional SSB phase noise and nonharmonic values. The user can choose between several low phase noise options to improve performance even more. The R&S®SMW-B711/-B721 ultra low phase noise options provide best possible performance for all carrier offsets. The R&S®SMW200A is perfect for measurements that place high requirements on spectral purity.

Phase-coherent signals up to 44 GHz

Beamforming applications, such as for measurements on active antenna systems, require high quality, phase-coherent test signals. More than just a common reference signal is usually needed to make sure that the relative phases remain stable over a long time period. The LO coupling offered by the R&S®SMW200A enables extremely precise and stable long-term phase synchronization of both generator paths. Up to 20 GHz, the generator can provide two phase-coherent RF paths in a single instrument, without additional cabling. If more phase-coherent carriers are needed, the internal LO signal of the R&S®SMW200A can be connected to another R&S®SMW200A or an R&S®SGS100A or R&S®SGU100A signal generator module.

Setup for antenna testing

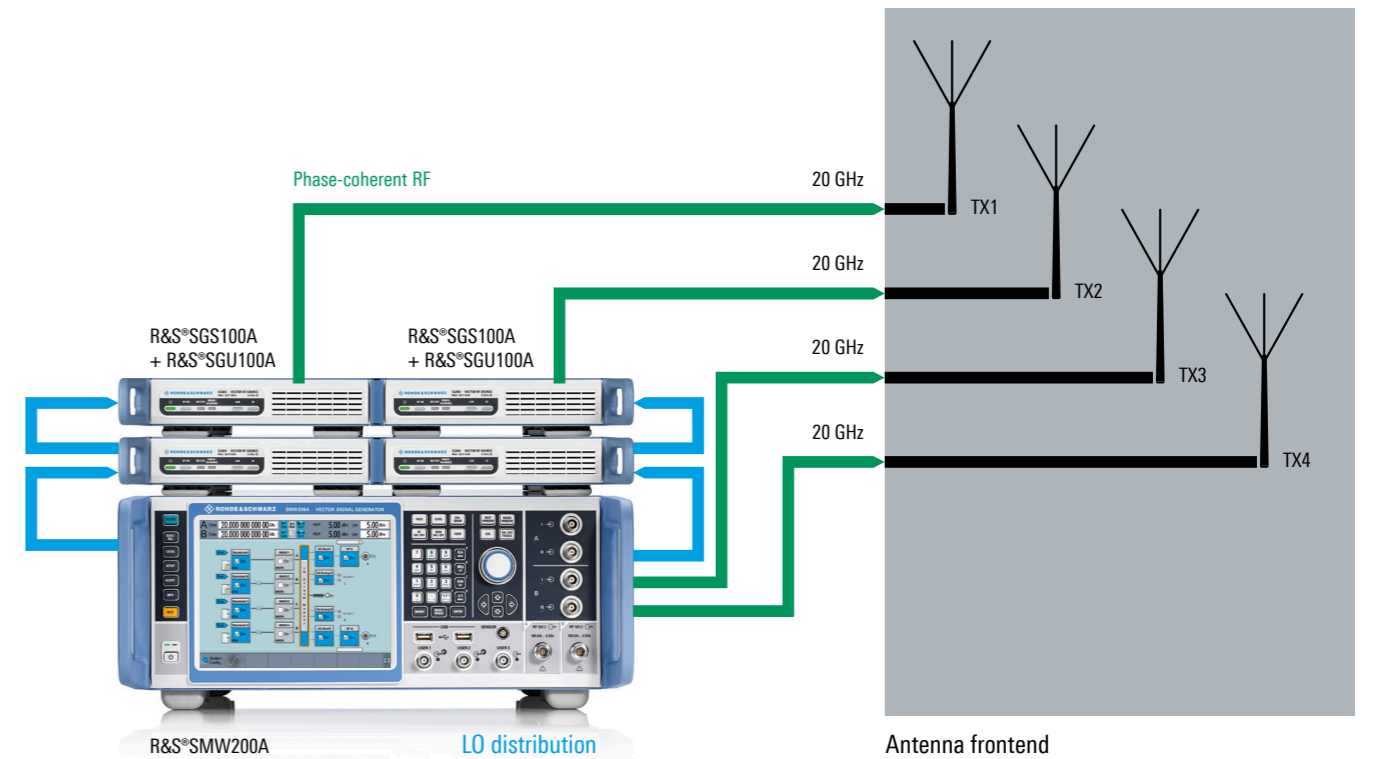

Setup with a two-path R&S®SMW200A, two R&S®SGS100A and two R&S®SGU100A to generate four phase-coherent CW or modulated signals, for example for antenna testing up to 20 GHz. The setup can be scaled to 40 GHz and duplicated if more RF paths are required.

SPEED UP YOUR DEVELOPMENT

Increasing cost pressure results in ever shorter development cycles. At the same time, testing requirements are becoming more stringent. The R&S®SMW200A accomplishes complex measurement tasks quickly and efficiently. Numerous innovations in intuitive user guidance make work extremely easy.

Ergonomic design for maximum operating convenience

A high resolution touchscreen and an easy-to-use graphical user interface make for ergonomic operation. A block diagram provides a clear overview at all times. The user sees at a glance the signal flow and the status of all inputs and outputs. The drag&drop functionality makes signal flow reconfiguration simpler than ever. For MIMO and other complex applications, the block diagram is adapted to the prevailing signal scenario.

All menu feature tabs for fast access to signal parameters. A context-sensitive online help system provides information about every parameter, such as setting range, detailed circuit description and SCPI command. Various functions facilitate everyday work, e.g. each parameter can be individually reset to its specific preset status.

The built-in graphics function of the R&S®SMW200A allows the generated signals to be displayed in realtime in up to eight simultaneous windows. The user can select the type of display (I and Q versus time, frequency spectrum, vector diagram, etc.) and the point in the signal flow where the measurement will be performed.

The baseband measurement function allows realtime measurement of the level of a signal or signal component at defined points in the signal flow. This feature is especially useful when the level of specific components of a complex signal is to be determined or varied during a measurement, as for example in closed-loop scenarios.

Automation made easy

The R&S®SMW200A can be controlled via all common remote interfaces. The user benefits from a number of help functions when programming an automatic test sequence control. The SCPI commands for every setting parameter can be displayed directly and all modifications of the instrument's preset status can be highlighted graphically. This makes it easy to identify all parameters that are important for remote control.

The R&S®SMW200A also has a built-in SCPI macro recorder with code generator, which records all manual operating steps to generate a file with a remote command sequence. Code templates are provided for directly generating executable code for MATLAB® or CVI. User-specific templates can also be used. As a result, the R&S®SMW200A contributes to minimizing the time required for test automation, saving development resources.

A fast instrument for speedy work

The LINUX based operating system of the R&S®SMW200A helps ensure short boot times. The high computer performance speeds up work even when settings require comprehensive signal calculation.

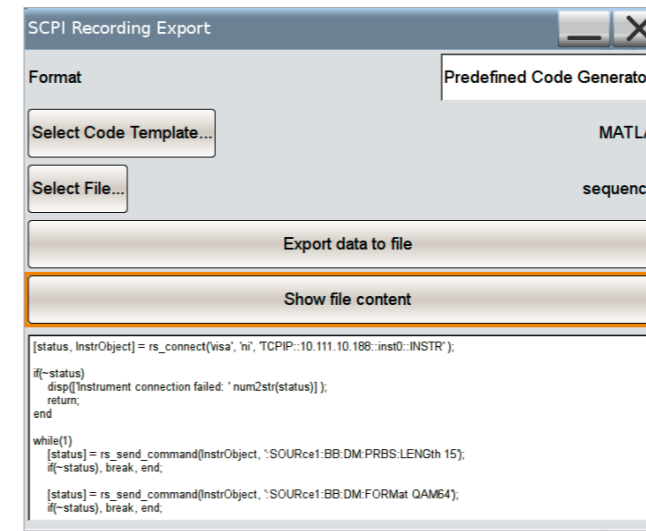

The built-in SCPI macro recorder and code generator supports fast, convenient generation of SCPI program sequences.

Context-sensitive online help system of the R&S®SMW200A

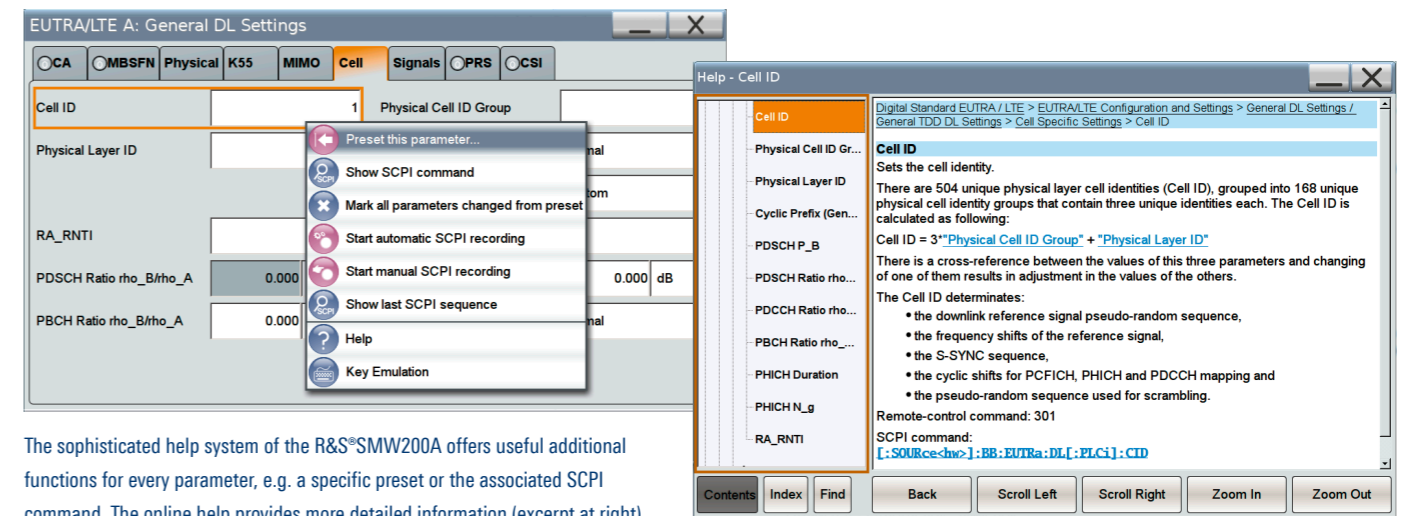

The sophisticated help system of the R&S®SMW200A offers useful additional functions for every parameter, e.g. a specific preset or the associated SCPI command. The online help provides more detailed information (excerpt at right).

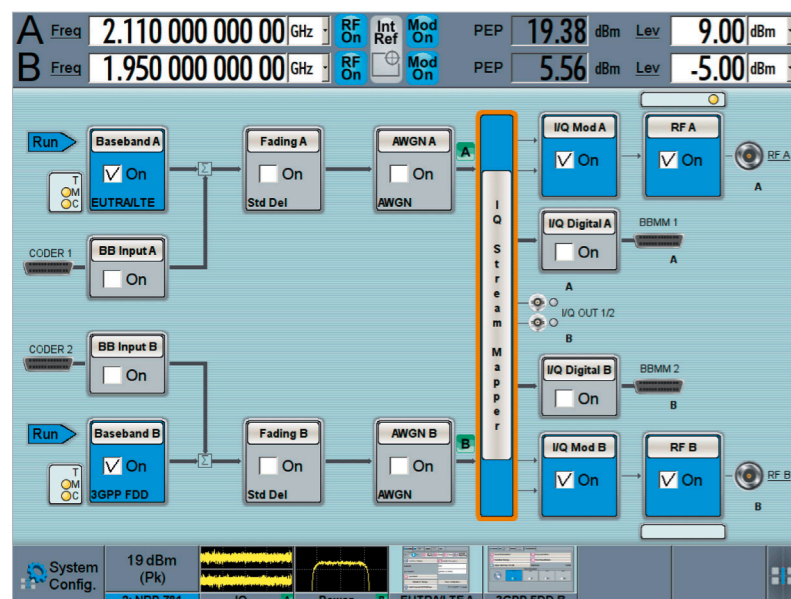

User interface of the R&S®SMW200A. The header shows the frequency, level and important instrument statuses. The footer provides quick access to open menus. The generated signals and the measurement results of any connected R&S®NRP-Zxx power sensor(s) can be displayed as well (second field from left in footer).

Graphical signal monitoring in realtime

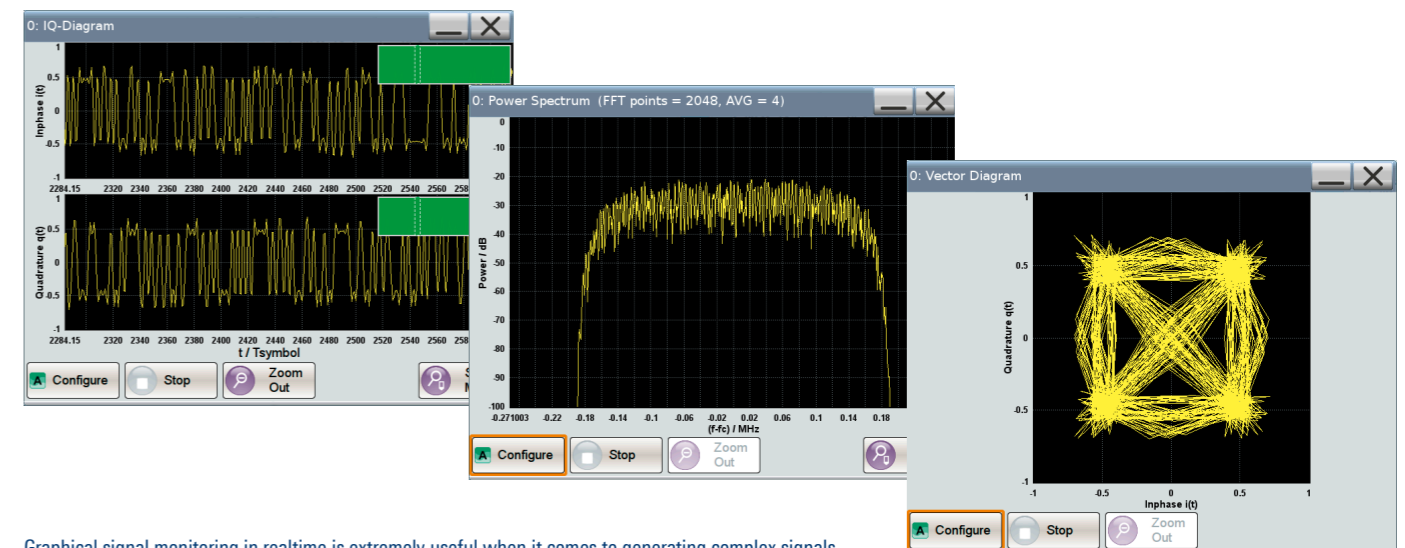

Graphical signal monitoring in realtime is extremely useful when it comes to generating complex signals.

GROWS WITH YOUR NEEDS

Advanced technology and a modular, upgradeable hardware concept make the R&S®SMW200A a future-ready investment.

R&S®SMW200A hardware options can be retrofitted with minimum effort. The baseband modules come as plug-ins and can easily be inserted into the rear panel without opening or recalibrating the instrument.

Software functions (e.g. digital standards) are simply activated via key codes. The R&S®SMW200A firmware can be updated from a USB flash drive or via LAN. Free updates can be downloaded from www.rohde-schwarz.com/product/smw200a.

In this way, the R&S®SMW200A can be precisely customized to suit the applications at hand and can be enhanced whenever new requirements arise. Users only have to purchase what they currently need and are free to decide on upgrades according to future requirements.



The R&S®SMW200A vector signal generator with a power sensor

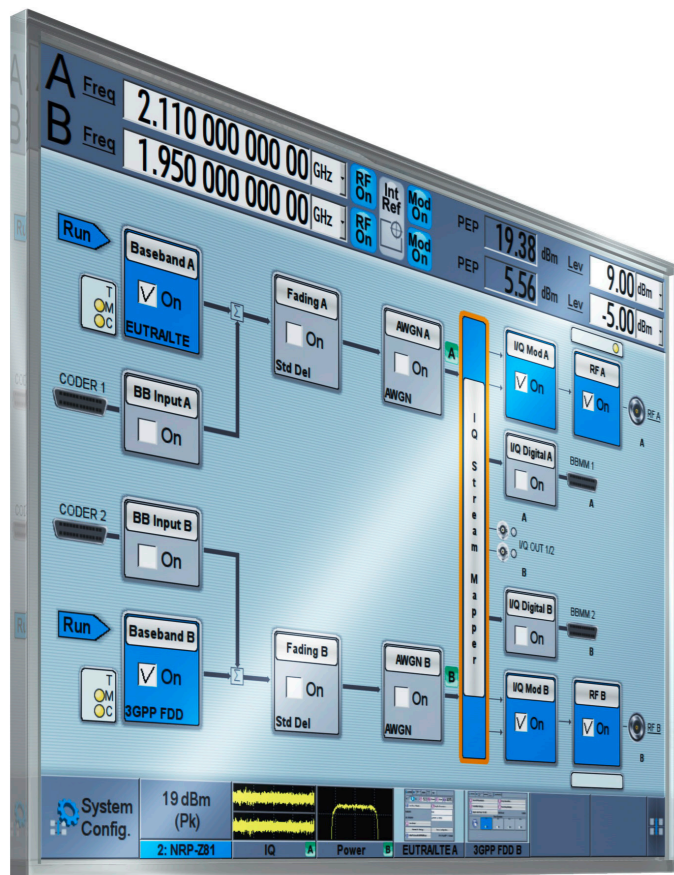

The R&S®SMW200A can be upgraded with various hardware and software options. For example, a large variety of digital standards is offered as software options.

The R&S®SMW200A can be used together with many other Rohde & Schwarz instruments

R&S®SMW200A function/connection	Related option(s)	Rohde & Schwarz partner instrument	Application example
Digital baseband input	R&S®SMW-B9/-B10	e.g. R&S®IQW IQ wideband recorder	record and replay of I/Q data
Digital baseband output	R&S®SMW-K18/-K19	e.g. R&S®SGT100A signal generator module	provides additional RF paths
Analog I/Q output	R&S®SMW-K16/-K17	e.g. R&S®SGS100A signal generator module	provides additional RF paths
R&S®NRP sensor connector	—	R&S®NRPxxS power sensors, R&S®NRP-Z28/-Z98 level control sensors	high precision power measurement, result display on the R&S®SMW200A

SPECIFICATIONS IN BRIEF

Specifications in brief		
Frequency		
Frequency range, RF path A	R&S®SMW-B1003	100 kHz to 3 GHz
	R&S®SMW-B1006	100 kHz to 6 GHz
	R&S®SMW-B1007	100 kHz to 7.5 GHz
	R&S®SMW-B1012	100 kHz to 12.75 GHz
	R&S®SMW-B1020	100 kHz to 20 GHz
	R&S®SMW-B1031	100 kHz to 31.8 GHz
	R&S®SMW-B1040/-B1040N	100 kHz to 40 GHz
	R&S®SMW-B1044/-B1044N	100 kHz to 44 GHz
Frequency range, RF path B (optional, see R&S®SMW200A data sheet for possible RF path configurations)	R&S®SMW-B2003	100 kHz to 3 GHz
	R&S®SMW-B2006	100 kHz to 6 GHz
	R&S®SMW-B2007	100 kHz to 7.5 GHz
	R&S®SMW-B2012	100 kHz to 12.75 GHz
	R&S®SMW-B2020	100 kHz to 20 GHz
	R&S®SMW-B2031	100 kHz to 31.8 GHz
	R&S®SMW-B2044/-B2044N	100 kHz to 44 GHz
Setting time	SCPI mode, $f < 6$ GHz	< 1.2 ms, 600 μ s (typ.)
Level		
Specified level range	$3 \text{ MHz} \leq f \leq 20 \text{ GHz}$	-120 dBm to +18 dBm (PEP)
	R&S®SMW-B1031/-B1040/-B1040N/-B1044/-B1044N/-B2020/-B2031/-B2044/-B2044N	-120 dBm to +11/+18 dBm (PEP), depending on RF
Setting time	SCPI mode	< 1 ms, 600 μ s (typ.)
	R&S®SMW-B1020/-B1031/-B1040/-B1040N/-B1044/-B1044N/-B2020/-B2031/-B2044/-B2044N, with switching of mechanical step attenuator	< 25 ms
Spectral purity		
Harmonics	level < 10 dBm, CW	< -30 dBc
	R&S®SMW-B1020/-B1031/-B1040/-B1040N/-B1044/-B1044N/-B2020, $f > 3.5$ GHz	< -55 dBc
Nonharmonics	CW or vector modulation with full-scale DC input, $200 \text{ MHz} < f \leq 1500 \text{ MHz}$	level > -10 dBm, carrier offset > 10 kHz
	standard	< -85 dBc
	with R&S®SMW-B711/-B721 option	< -95 dBc
SSB phase noise	CW, carrier offset = 10 kHz, $f = 1$ GHz	
	standard	< -134 dBc
	with R&S®SMW-B709/-B719 option	< -139 dBc
	with R&S®SMW-B711/-B721 option	< -144 dBc, -150 dBc (typ.)
	CW, carrier offset = 10 kHz, $f = 10$ GHz	
	standard	< -114 dBc
	with R&S®SMW-B709/-B719 option	< -119 dBc
	with R&S®SMW-B711/-B721 option	< -124 dBc, -130 dBc (typ.)
Analog modulation		
Supported analog modulation modes	depending on options	AM, FM, ϕ M, pulse

Specifications in brief		
I/Q modulation		
RF modulation bandwidth	with internal wideband baseband, "I/Q wideband" on	
	$1 \text{ MHz} \leq f \leq 300 \text{ MHz}$	$\pm 32\%$ of carrier frequency
	$300 \text{ MHz} < f \leq 2.5 \text{ GHz}$	$\pm 40\%$ of carrier frequency
	$f > 2.5 \text{ GHz}$	± 1 GHz
	with internal standard baseband, "I/Q wideband" on	
	$1 \text{ MHz} \leq f \leq 250 \text{ MHz}$	$\pm 32\%$ of carrier frequency
	$f > 250 \text{ MHz}$	± 80 MHz
Modulation frequency response in specified RF modulation bandwidth	with internal baseband, "I/Q wideband" on	< 1.0 dB, < 0.4 dB (meas.)
Wideband baseband generator		
	R&S®SMW-B9 option, up to two wideband baseband generators can be installed	
Signal bandwidth	standard	500 MHz
	with R&S®SMW-K525 option	1 GHz
	with R&S®SMW-K525 and -K527 options	2 GHz
ARB memory depth	standard	256 Msample
	with R&S®SMW-K515 option	2 Gsample
Frequency offset	standard	-250 MHz to +250 MHz
	with R&S®SMW-K525 option	-500 MHz to +500 MHz
	with R&S®SMW-K525 and -K527 options	-1000 MHz to +1000 MHz
Standard baseband generator		
	R&S®SMW-B10 option, up to two baseband generators can be installed	
Signal bandwidth	standard	120 MHz
	with R&S®SMW-K522 option	160 MHz
ARB memory depth	standard	64 Msample
	with R&S®SMW-K511 option	512 Msample
	with R&S®SMW-K511 and -K512 options	1 Gsample
Frequency offset	standard	-60 MHz to +60 MHz
	with R&S®SMW-K522 option	-80 MHz to +80 MHz
Digital standards		
Supported standards and modulation systems	5G NR Releases 15 and 16, LTE Releases 8 to 15, NB-IoT, eMTC, 3GPP FDD/HSPA/HSPA+, GSM/EDGE/EDGE Evolution, WLAN IEEE 802.11a/b/g/n/j/p/ac/ax/ad/be, GNSS, AWGN and more	
Fading and MIMO		
Fading simulator	R&S®SMW-B14/-B15 option, up to four fading modules can be installed	
Fading bandwidth	depending on options	max. 800 MHz
Fading channels	depending on options	max. 64
MIMO fading scenarios	depending on options	2x2, 3x3, 4x4, 8x4, 4x8, 2x2x2, 2x4x2, 2x2x4, 4x2x2 and more
Fading modes	depending on options	multipath, moving delay, birth-death, high speed train, two-channel interferer
Fading profiles	depending on options	Rayleigh, Rice, pure Doppler, static path, Gaussian, customized and more

The Bluetooth® word mark and logos are registered trademarks owned by Bluetooth SIG, Inc. and any use of such marks by Rohde&Schwarz is under license. CDMA2000® is a registered trademark of the Telecommunications Industry Association (TIA-USA).

Options for digital communications standards (selection)

Standard/technology	Options	Key features
5G NR	R&S®SMW-K144/-K145/-K148/-K175	<ul style="list-style-type: none"> ▶ In line with 3GPP Releases 15 and 16 ▶ Downlink and uplink signals for FR1 and FR2 ▶ All numerologies and channel bandwidths ▶ Support of multiple bandwidth part (BWP) with mixed numerology ▶ Support of uplink closed-loop base station tests in line with 3GPP TS38.141
LTE/LTE-Advanced	R&S®SMW-K55/-K69/-K81/-K84/-K85/-K112/-K113/-K119	<ul style="list-style-type: none"> ▶ In line with 3GPP LTE Releases 8, 9, 10, 11, 12, 13, 14, 15 ▶ FDD and TDD ▶ Downlink (OFDMA) and uplink (SC-FDMA) ▶ Carrier aggregation ▶ Support of uplink closed loop base station tests in line with 3GPP TS36.141 ▶ LTE test case wizard
Cellular IoT	R&S®SMW-K115/-K143/-K146	<ul style="list-style-type: none"> ▶ In line with 3GPP Releases 13, 14, 15 ▶ NB-IoT and eMTC downlink and uplink signal generation ▶ NB-IoT in-band, guard band and standalone modes ▶ Realtime processing of HARQ feedback commands for closed loop base station tests
3GPP FDD/HSPA/HSPA+	R&S®SMW-K42/-K83	<ul style="list-style-type: none"> ▶ In line with 3GPP FDD Release 11 ▶ Downlink and uplink ▶ HSDPA H-sets ▶ Higher order modulation, MIMO, CPC ▶ Support of base station tests in line with 3GPP TS25.141 ▶ 3GPP test case wizard

Standard/technology	Options	Key features
GSM/EDGE/EDGE Evolution	R&S®SMW-K40/-K41	<ul style="list-style-type: none"> ▶ MSK, FSK, AQPSK, 8PSK, 16QAM and 32QAM modulation ▶ Mixed frames with GSM, EDGE and EGPRS2 slots ▶ VAMOS support ▶ Support of higher symbol rates (325 kHz) ▶ “Framed double” sequence mode for generating realistic test scenarios with changing frame content
WLAN IEEE802.11a/b/g/n/j/p/ac/ax/be	R&S®SMW-K54/-K86/-K142/-K147	<ul style="list-style-type: none"> ▶ Support of all mandatory physical layer modes ▶ VHT frames with up to 160 MHz transmission bandwidth ▶ BPSK, QPSK, 16QAM and 256QAM modulation ▶ MIMO modes with four transmit antennas ▶ Frame block sequencer for alternating legacy frames in line with 11a/b/g/j/p, 11n or 11ac
WLAN IEEE802.11ad	R&S®SMW-K141	<ul style="list-style-type: none"> ▶ In line with IEEE802.11ad-2012 ▶ Support of control, single carrier, OFDM and low-power single carrier modes ▶ Modulation and coding schemes 0 to 31 ▶ Support of aggregated MPDUs
GNSS	R&S®SMW-K44/-K66/-K94/-K98/-K106/-K107/-K132	<ul style="list-style-type: none"> ▶ Support of GPS, GLONASS, Galileo, BeiDou and QZSS/SBAS, including hybrid constellations ▶ Realtime simulation of realistic constellations with unlimited simulation time ▶ Flexible scenario generation including moving scenarios, dynamic power control and atmospheric modeling ▶ Configuration of realistic user environments, including obscuration and multipath, antenna characteristics and vehicle attitude

Rear panel of the R&S®SMW200A.

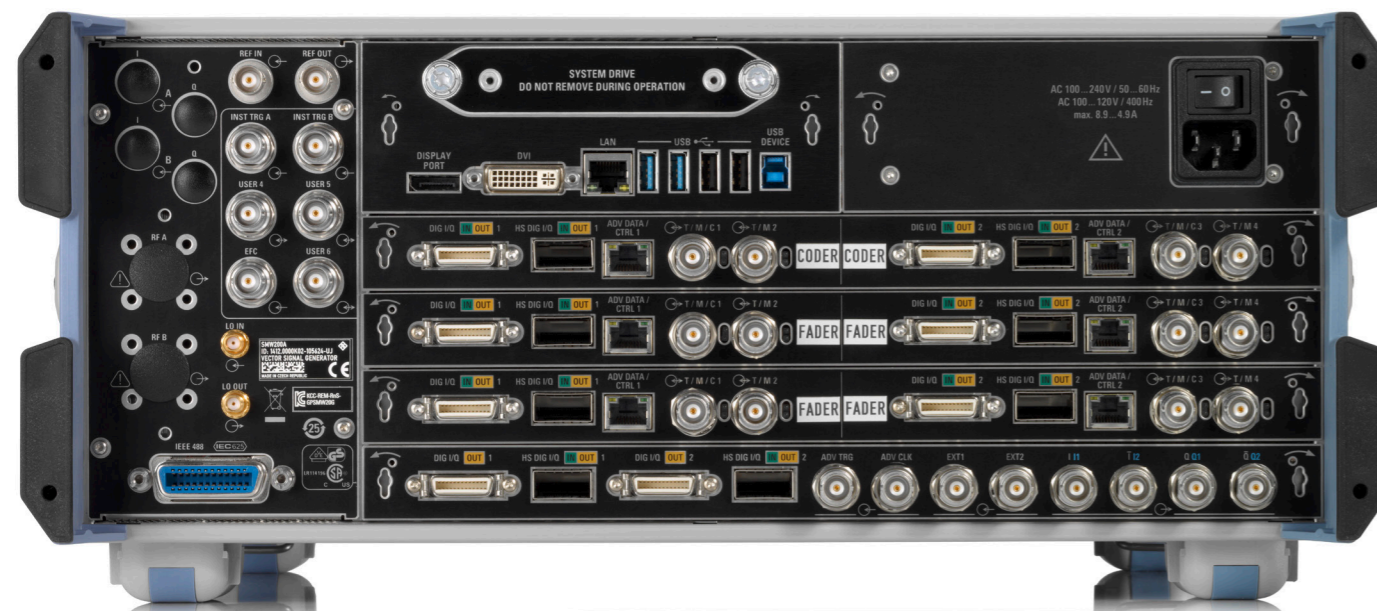

For more information, see www.rohde-schwarz.com/product/smw200a and

- ▶ R&S®SMW200A data sheet (PD 3606.8037.22)
- ▶ R&S®SMW200A configuration guide (PD 3606.8037.92)
- ▶ “Digital Standards for Signal Generators” data sheet (PD 5213.9434.22)
- ▶ “GNSS and Avionics Simulation for Rohde&Schwarz Signal Generators” data sheet (PD 3607.6896.22)

ORDERING INFORMATION

Designation	Type	Order No.
Vector signal generator¹⁾ including power cable and quick start guide	R&S®SMW200A	1412.0000.02
Options R&S®SMW-Bxxx = hardware option R&S®SMW-Kxxx = software/keycode option		
Frequency options, RF path A		
100 kHz to 3 GHz	R&S®SMW-B1003	1428.4700.02
100 kHz to 6 GHz	R&S®SMW-B1006	1428.4800.02
100 kHz to 7.5 GHz	R&S®SMW-B1007	1428.7700.02
100 kHz to 12.75 GHz	R&S®SMW-B1012	1428.4900.02
100 kHz to 20 GHz	R&S®SMW-B1020	1428.5107.02
100 kHz to 31.8 GHz	R&S®SMW-B1031	1428.5307.02
100 kHz to 40 GHz	R&S®SMW-B1040	1428.8506.02
100 kHz to 40 GHz, I/Q modulation bandwidth and minimum pulse width limited	R&S®SMW-B1040N	1428.8606.02
100 kHz to 44 GHz	R&S®SMW-B1044	1428.5507.02
100 kHz to 44 GHz, I/Q modulation bandwidth and minimum pulse width limited	R&S®SMW-B1044N	1428.5407.02
Signal routing and baseband main modules		
Signal routing and baseband main module, one I/Q path to RF	R&S®SMW-B13	1413.2807.02
Signal routing and baseband main module, two I/Q paths to RF	R&S®SMW-B13T	1413.3003.02
Wideband signal routing and baseband main module, two I/Q paths to RF	R&S®SMW-B13XT	1413.8005.02
Phase noise performance options, RF path A		
Low phase noise for RF path A	R&S®SMW-B709	1428.7300.02
Improved close-in phase noise performance for RF path A	R&S®SMW-B710	1428.6503.02
Ultra low phase noise for RF path A	R&S®SMW-B711	1428.6703.02
Platform option		
Deeper chassis ²⁾	R&S®SMW-B94L	1438.8150.02
Frequency options, RF path B		
100 kHz to 3 GHz	R&S®SMW-B2003	1428.5707.02
100 kHz to 6 GHz	R&S®SMW-B2006	1428.5807.02
100 kHz to 7.5 GHz	R&S®SMW-B2007	1428.7900.02
100 kHz to 12.75 GHz	R&S®SMW-B2012	1438.8950.02
100 kHz to 20 GHz	R&S®SMW-B2020	1428.6103.02
100 kHz to 31.8 GHz	R&S®SMW-B2031	1438.8750.02
100 kHz to 44 GHz	R&S®SMW-B2044	1438.8350.02
100 kHz to 44 GHz, I/Q modulation bandwidth and minimum pulse width limited	R&S®SMW-B2044N	1438.8550.02
Phase noise performance options, RF path B		
Low phase noise for RF path B	R&S®SMW-B719	1428.7500.02
Improved close-in phase noise performance for RF path B	R&S®SMW-B720	1428.6903.02
Ultra low phase noise for RF path B	R&S®SMW-B721	1428.7100.02
Other RF options		
Phase coherence	R&S®SMW-B90	1413.5841.02
Pulse modulator	R&S®SMW-K22	1413.3249.02
Pulse generator	R&S®SMW-K23	1413.3284.02
Multifunction generator	R&S®SMW-K24	1413.3332.02
100 MHz, 1 GHz ultra low noise reference input/output	R&S®SMW-K703	1413.7380.02
Flexible reference input from 1 MHz to 100 MHz	R&S®SMW-K704	1414.6541.02

¹⁾ The base unit can only be ordered with an R&S®SMW-B10xx frequency option and an R&S®SMW-B13, R&S®SMW-B13T or R&S®SMW-B13XT signal routing and baseband main module.

²⁾ This option is required (and only possible) for RF path combinations 2 × 12.75 GHz, 2 × 31.8 GHz and 2 × 44 GHz.

Designation	Type	Order No.
AM/FM/φM	R&S®SMW-K720	1413.7438.02
Differential analog I/Q inputs	R&S®SMW-K739	1413.7167.02
Standard baseband		
Baseband generator with ARB (64 Msample) and digital modulation (realtime), 120 MHz RF bandwidth	R&S®SMW-B10	1413.1200.02
Baseband generator for GNSS with high dynamics, with ARB (64 Msample) and digital modulation (realtime), 120 MHz RF bandwidth	R&S®SMW-B10F	1414.4303.02
Differential analog I/Q outputs	R&S®SMW-K16	1413.3384.02
Digital baseband output	R&S®SMW-K18	1413.3432.02
Extended sequencing	R&S®SMW-K501	1413.9218.02
ARB memory extension to 512 Msample	R&S®SMW-K511	1413.6860.02
ARB memory extension to 1 Gsample	R&S®SMW-K512	1413.6919.02
Baseband extension to 160 MHz RF bandwidth	R&S®SMW-K522	1413.6960.02
Slow I/Q	R&S®SMW-K551	1413.9724.02
Wideband baseband		
Wideband baseband generator with ARB (256 Msample), 500 MHz RF bandwidth	R&S®SMW-B9	1413.7350.02
Wideband differential analog I/Q outputs	R&S®SMW-K17	1414.2346.02
Digital baseband output	R&S®SMW-K19	1414.3865.02
Wideband extended sequencing	R&S®SMW-K502	1413.9260.02
Realtime control interface	R&S®SMW-K503	1414.3620.02
Realtime control interface with enhanced PDW rate and control PDWs	R&S®SMW-K504	1414.3665.02
ARB memory extension to 2 Gsample	R&S®SMW-K515	1413.9360.02
Baseband extension to 1 GHz RF bandwidth	R&S®SMW-K525	1414.6129.02
Baseband extension to 2 GHz RF bandwidth	R&S®SMW-K527	1414.6158.02
Baseband enhancements		
Additive white Gaussian noise (AWGN)	R&S®SMW-K62	1413.3484.02
Bit error rate tester	R&S®SMW-K80	1414.6187.02
Envelope tracking	R&S®SMW-K540	1413.7215.02
AM/AM, AM/φM predistortion	R&S®SMW-K541	1413.7267.02
User-defined frequency response correction	R&S®SMW-K544	1414.3707.02
Digital Doherty	R&S®SMW-K546	1414.6487.02
Crest factor reduction	R&S®SMW-K548	1414.6641.02
Enhanced noise generation	R&S®SMW-K810	1414.6341.02
Notched signals	R&S®SMW-K811	1414.6364.02
Multichannel, MIMO and fading		
Fading simulator	R&S®SMW-B14	1413.1500.02
Fading simulator and signal processor	R&S®SMW-B15	1414.4710.02
Dynamic fading	R&S®SMW-K71	1413.3532.02
Enhanced fading models	R&S®SMW-K72	1413.3584.02
OTA-MIMO fading enhancements	R&S®SMW-K73	1414.2300.02
MIMO fading/routing	R&S®SMW-K74	1413.3632.02
Higher order MIMO	R&S®SMW-K75	1413.9576.02
Multiple entities	R&S®SMW-K76	1413.9624.02
Radar echo generation	R&S®SMW-K78	1414.1833.02
Stream extender	R&S®SMW-K550	1413.7315.02
Customized dynamic fading	R&S®SMW-K820	1414.2581.02
MIMO subsets for higher order MIMO	R&S®SMW-K821	1414.4403.02
Fading bandwidth extension to 400 MHz	R&S®SMW-K822	1414.6712.02
Fading bandwidth extension to 400 MHz	R&S®SMW-K823	1414.6735.02

Designation	Type	Order No.
Digital standards		
GSM/EDGE	R&S°SMW-K40	1413.3684.02
EDGE Evolution	R&S°SMW-K41	1413.3732.02
3GPP FDD	R&S°SMW-K42	1413.3784.02
GPS	R&S°SMW-K44	1413.3832.02
CDMA2000°	R&S°SMW-K46	1413.3884.02
1xEV-DO	R&S°SMW-K47	1413.3932.02
IEEE 802.16	R&S°SMW-K49	1413.3984.02
TD-SCDMA	R&S°SMW-K50	1413.4039.02
TD-SCDMA enhanced BS/MS tests	R&S°SMW-K51	1413.4080.02
DVB-H/DVB-T	R&S°SMW-K52	1413.6090.02
IEEE 802.11 (a/b/g/n)	R&S°SMW-K54	1413.4139.02
EUTRA/LTE	R&S°SMW-K55	1413.4180.02
Bluetooth° EDR	R&S°SMW-K60	1413.4239.02
Multicarrier CW signal generation	R&S°SMW-K61	1413.4280.02
Galileo	R&S°SMW-K66	1413.4380.02
TETRA Release 2	R&S°SMW-K68	1413.4439.02
LTE closed-loop BS test	R&S°SMW-K69	1413.4480.02
Log file generation	R&S°SMW-K81	1413.4539.02
3GPP FDD HSPA/HSPA+, enhanced BS/MS tests	R&S°SMW-K83	1413.4580.02
EUTRA/LTE Release 9 and enhanced features	R&S°SMW-K84	1413.5435.02
EUTRA/LTE Release 10 (LTE-Advanced)	R&S°SMW-K85	1413.5487.02
IEEE 802.11ac	R&S°SMW-K86	1413.5635.02
1xEV-DO Rev. B	R&S°SMW-K87	1413.6519.02
NFC A/B/F	R&S°SMW-K89	1413.6619.02
GLONASS	R&S°SMW-K94	1414.1485.02
NavIC/IRNSS	R&S°SMW-K97	1414.6258.02
Modernized GPS	R&S°SMW-K98	1414.1533.02
SBAS/QZSS	R&S°SMW-K106	1414.2923.02
BeiDou	R&S°SMW-K107	1414.1585.02
Real-world scenarios	R&S°SMW-K108	1414.2975.02
GNSS realtime interfaces (RT remote control)	R&S°SMW-K109	1414.3013.02
LTE Release 11 and enhanced features	R&S°SMW-K112	1413.8505.02
EUTRA/LTE Release 12	R&S°SMW-K113	1414.1933.02
OFDM signal generation	R&S°SMW-K114	1414.1985.02
Cellular IoT	R&S°SMW-K115	1414.2723.02
DVB-S2/DVB-S2X	R&S°SMW-K116	1414.2630.02
Bluetooth° 5.x	R&S°SMW-K117	1414.3336.02
Verizon 5GTF signals	R&S°SMW-K118	1414.3465.02
LTE Release 13/14/15	R&S°SMW-K119	1414.3542.02
OneWeb user-defined signal generation	R&S°SMW-K130	1414.3788.02
LoRa°	R&S°SMW-K131	1414.6464.02
Modernized BeiDou	R&S°SMW-K132	1414.6606.02
Upgrade to dual-frequency GNSS	R&S°SMW-K134	1414.6770.02
Upgrade to triple-frequency GNSS	R&S°SMW-K135	1414.6793.02
6 additional GNSS channels	R&S°SMW-K136	1414.6812.02
12 additional GNSS channels	R&S°SMW-K137	1414.6835.02
24 additional GNSS channels	R&S°SMW-K138	1414.6858.02
48 additional GNSS channels	R&S°SMW-K139	1414.6935.02
IEEE 802.11ad	R&S°SMW-K141	1414.1333.02
IEEE 802.11ax	R&S°SMW-K142	1414.3259.02
Cellular IoT Release 14	R&S°SMW-K143	1414.6064.02
5G New Radio	R&S°SMW-K144	1414.4990.02

Designation	Type	Order No.
5G New Radio closed-loop BS test	R&S°SMW-K145	1414.6506.02
Cellular IoT Release 15	R&S°SMW-K146	1414.6564.02
IEEE 802.11be	R&S°SMW-K147	1413.6677.02
5G New Radio Release 16	R&S°SMW-K148	1414.6664.02
HRP UWB	R&S°SMW-K149	1414.6912.02
U-plane generation	R&S°SMW-K175	1413.3261.02
OneWeb reference signals	R&S°SMW-K355	1414.3742.02
ERA-GLONASS test suite	R&S°SMW-K360	1414.2800.02
eCall test suite	R&S°SMW-K361	1414.2846.02
Baseband power sweep	R&S°SMW-K542	1413.9876.02
Digital standards using R&S°WinIQSIM2™ ³⁾		
GSM/EDGE	R&S°SMW-K240	1413.4739.02
EDGE Evolution	R&S°SMW-K241	1413.4780.02
3GPP FDD	R&S°SMW-K242	1413.4839.02
GPS 1 satellite	R&S°SMW-K244	1413.4880.02
CDMA2000°	R&S°SMW-K246	1413.4939.02
1xEV-DO	R&S°SMW-K247	1413.4980.02
IEEE 802.16	R&S°SMW-K249	1413.5035.02
TD-SCDMA	R&S°SMW-K250	1413.5087.02
TD-SCDMA enhanced BS/MS tests	R&S°SMW-K251	1413.5135.02
DVB-H/DVB-T	R&S°SMW-K252	1413.6190.02
DAB/T-DMB	R&S°SMW-K253	1413.6248.02
IEEE 802.11n	R&S°SMW-K254	1413.5187.02
EUTRA/LTE	R&S°SMW-K255	1413.5235.02
Bluetooth° EDR	R&S°SMW-K260	1413.5287.02
Multicarrier CW signal generation	R&S°SMW-K261	1413.5335.02
Additive white Gaussian noise (AWGN)	R&S°SMW-K262	1413.6460.02
Galileo 1 satellite	R&S°SMW-K266	1413.7015.02
TETRA Release 2	R&S°SMW-K268	1413.5387.02
3GPP FDD HSPA/HSPA+, enhanced BS/MS tests	R&S°SMW-K283	1413.6290.02
EUTRA/LTE Release 9 and enhanced features	R&S°SMW-K284	1413.5535.02
EUTRA/LTE Release 10 (LTE-Advanced)	R&S°SMW-K285	1413.5587.02
IEEE 802.11ac	R&S°SMW-K286	1413.5687.02
1xEV-DO Rev. B	R&S°SMW-K287	1413.6560.02
NFC A/B/F	R&S°SMW-K289	1413.6654.02
Glionass 1 satellite	R&S°SMW-K294	1413.7067.02
Beidou 1 satellite	R&S°SMW-K407	1413.7115.02
LTE Release 11 and enhanced features	R&S°SMW-K412	1413.8557.02
EUTRA/LTE Release 12	R&S°SMW-K413	1414.2030.02
OFDM signal generation	R&S°SMW-K414	3636.0434.02
Cellular IoT	R&S°SMW-K415	1414.2769.02
DVB-S2/DVB-S2X	R&S°SMW-K416	1414.2681.02
Bluetooth° 5.x	R&S°SMW-K417	1414.3371.02
Verizon 5GTF signals	R&S°SMW-K418	1414.3507.02
LTE Release 13/14/15	R&S°SMW-K419	1414.3588.02
OneWeb user-defined signal generation	R&S°SMW-K430	1414.3820.02
LoRa°	R&S°SMW-K431	1414.6441.02
IEEE 802.11ad	R&S°SMW-K441	1414.1385.02
IEEE 802.11ax	R&S°SMW-K442	1414.3294.02
Cellular IoT Release 14	R&S°SMW-K443	1414.6093.02
5G New Radio	R&S°SMW-K444	1414.5022.02
Cellular IoT Release 15	R&S°SMW-K446	1414.6587.02

³⁾ R&S°WinIQSIM2™ requires an external PC.

Designation	Type	Order No.
Options with external R&S®Pulse Sequencer software or R&S®Pulse Sequencer (DFS) software		
Pulse sequencing	R&S®SMW-K300	1413.8805.02
Enhanced pulse sequencing	R&S®SMW-K301	1413.9776.02
Moving emitters and receiver	R&S®SMW-K304	1413.8957.02
Multiple emitters (interleaved)	R&S®SMW-K306	1413.9053.02
Direction finding	R&S®SMW-K308	1414.1433.02
Pulse-on-pulse simulation	R&S®SMW-K315	1414.6529.02
DFS signal generation	R&S®SMW-K350	1413.9160.02
Waveform packages for signals from R&S®WinIQSIM2™ 4)		
1 waveform	R&S®SMW-K200	1414.6870.71
5 waveforms	R&S®SMW-K200	1414.6870.72
50 waveforms	R&S®SMW-K200	1414.6870.75
Other options		
Rear panel connectors for RF path A (3/6 GHz) and I/Q	R&S®SMW-B81	1413.5893.02
Rear panel connectors for RF path B (3/6 GHz)	R&S®SMW-B82	1413.5941.02
Rear panel connectors for RF path A (20/31.8/40 GHz) and I/Q	R&S®SMW-B83	1414.0937.02
Rear panel connectors for RF path B (20 GHz)	R&S®SMW-B84	1414.1033.02
Solid state drive	R&S®SMW-B93	1414.1885.02
Recommended extras		
19" rack adapter	R&S®ZZA-KN4	1175.3033.00
Cable for connecting Rohde & Schwarz digital baseband interfaces	R&S®SMU-Z6	1415.0201.02
Cable for HS digital I/Q interface (optical cable, QFSP+ plug)	R&S®DIGIQ-HS	3641.2948.03
USB serial adapter for RS-232 remote control	R&S®TS-USB1	6124.2531.00
Adapters for instruments with an R&S®SMW-B1012/-B2012/-B1020/-B2020/-B1031/-B2031/-B1040/-B1040N frequency option		
Test port adapter, 2.92 mm female		1036.4790.00
Test port adapter, 2.92 mm male		1036.4802.00
Test port adapter, N female		1036.4777.00
Test port adapter, N male		1036.4783.00
Adapters for instruments with an R&S®SMW-B1044/-B2044/-B1044N/-B2044N frequency option		
Coaxial adapter 1.85 mm (f) – 1.85 mm (f)		3588.9654.00
Coaxial adapter 1.85 mm (f) – 2.92 mm (f)		3628.4728.02
Documentation		
Documentation of calibration values	R&S®DCV-2	0240.2193.18
R&S®SMW200A accredited calibration, up to 6 GHz	R&S®ACASMW200A	3596.7005.03
R&S®SMW200A accredited calibration, 7.5 GHz	R&S®ACASMW200A	3598.3507.03
R&S®SMW200A accredited calibration, 12.75 GHz to 44 GHz	R&S®ACASMW200A	3596.7011.03

4) A maximum of 250 waveforms per instrument can be registered.

Your local Rohde & Schwarz expert will help you determine the optimum solution for your requirements.

To find your nearest Rohde & Schwarz representative, visit

www.sales.rohde-schwarz.com

Warranty		
Base unit	3 years	
All other items ¹⁾	1 year	
Options		
Extended warranty, one year	R&S®WE1	
Extended warranty, two years	R&S®WE2	
Extended warranty with calibration coverage, one year	R&S®CW1	Please contact your local
Extended warranty with calibration coverage, two years	R&S®CW2	Rohde & Schwarz sales office.
Extended warranty with accredited calibration coverage, one year	R&S®AW1	
Extended warranty with accredited calibration coverage, two years	R&S®AW2	

¹⁾ For options that are installed, the remaining base unit warranty applies if longer than 1 year. Exception: all batteries have a 1 year warranty.

FROM PRESALES TO SERVICE. AT YOUR DOORSTEP.

The Rohde & Schwarz network in over 70 countries ensures optimum on-site support by highly qualified experts.

User risks are reduced to a minimum at all project stages:

- ▶ Solution finding/purchase
- ▶ Technical startup/application development/integration
- ▶ Training
- ▶ Operation/calibration/repair

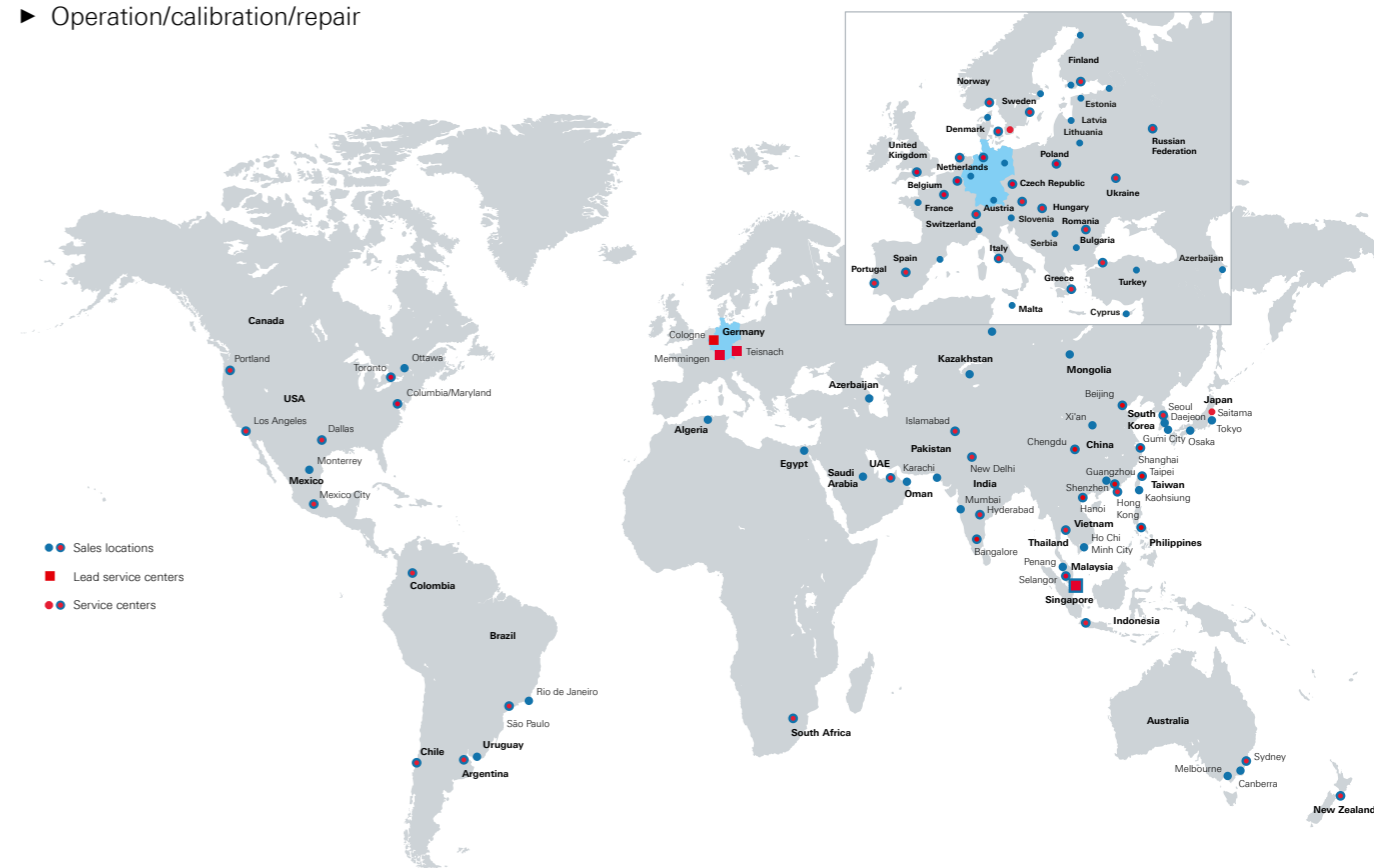

Service that adds value

- ▶ Worldwide
- ▶ Local and personalized
- ▶ Customized and flexible
- ▶ Uncompromising quality
- ▶ Long-term dependability

Rohde & Schwarz

The Rohde & Schwarz electronics group offers innovative solutions in the following business fields: test and measurement, broadcast and media, secure communications, cybersecurity, monitoring and network testing. Founded more than 80 years ago, the independent company which is headquartered in Munich, Germany, has an extensive sales and service network with locations in more than 70 countries.

www.rohde-schwarz.com

Sustainable product design

- ▶ Environmental compatibility and eco-footprint
- ▶ Energy efficiency and low emissions
- ▶ Longevity and optimized total cost of ownership

Certified Quality Management

ISO 9001

Certified Environmental Management

ISO 14001

Rohde & Schwarz training

www.training.rohde-schwarz.com

Rohde & Schwarz customer support

www.rohde-schwarz.com/support

