

# E5080B ENA Series Vector Network Analyzers

9 kHz to 53 GHz, 2/4-port

Drive Down the Cost of Test

9 kHz to 4.5/6.5/9/14/18/20 GHz

100 kHz to 26.5/32/44/53 GHz



# Table of Contents

E5080B ENA Series Vector Network Analyzer Configurations .....	4
Test set options .....	4
Spectrum analysis hardware options.....	5
Internal bias tees options.....	5
Hardware options.....	6
Application software.....	7
Calibration options .....	8
Accessories .....	8
E5080B Test set options and Block Diagrams .....	9
E5080B Option 240/260/290/2D0/2K0 (2-port base options).....	9
E5080B Option 2L0/2M0/2N0/2P0 (2-port base options).....	9
E5080B Option 440/460/490/4D0/4K0 (4-port base options).....	10
E5080B Option 4L0/4M0/4N0/4P0 (4-port base options).....	10
E5080B Option 442/462/492/4D2/4K2 (4-port second source option).....	11
E5080B Option 4L2/4M2/4N2/4P2 (4-port second source options) .....	11
Measurement Application Software.....	12
Automatic fixture removal (S96007B).....	12
Time domain analysis (S96010B).....	12
Enhanced time domain analysis with TDR (S96011B).....	12
Real time S-parameter and power measurement uncertainty (S96015B) .....	12
Basic pulsed-RF measurements (S96025B) .....	13
Noise figure measurements with vector correction (S96029B) .....	13
Impedance analysis (S96041B).....	14
Scalar mixer/converter measurements (S96082B) .....	14
Vector and scalar mixer/converter measurements (S96083B).....	14
Embedded LO capability (S96084B) .....	15
Gain compression measurements (S96086B) .....	15
Intermodulation distortion measurements (S96087B) .....	15
Source phase control (S96088B) .....	15
Differential and I/Q device measurements (S96089B) .....	16
Spectrum analysis (S96090B) .....	16
True-mode stimulus (S96460B).....	16
Multiport calibration assistant (S96552B).....	17
Material measurements .....	17
N1930xB Physical Layer Test System (PLTS) software .....	17
Vector Network Analyzer (VNA) simulator (S9405xB) .....	17
Device Measurement eXpert (DMX) (S94601B) .....	17
Limit assistant (S94602B).....	18
Automated Measurement Expert (AMX).....	18
USB Type-C interconnects compliance test software (S94USBCB).....	18
E5080B Hardware Configurations .....	19
Pulse modulation hardware (Option 021) .....	19
Pulse modulation hardware (Option 022).....	19
High stability time base (Option 1E5) .....	19
Internal bias tees (Option 120 or 140).....	19
Analog input and output (Option 175).....	20
Device Test I/O .....	20
Application I/O .....	20

Direct Receiver Access (DRA) Configurations .....	21
DRA configuration with high-power .....	21
Keysight Software Licensing Options Provide Flexibility and Support .....	22
Choose your term. Choose your type. Keep control of your budget. ....	22
KeysightCare Software Support Subscription provides peace of mind amid evolving technologies. ....	23
Ordering Information.....	23
E5092A Configurable Multiport Test Set .....	24
Test set options .....	24
Cable and adapter options .....	24
Docking plate options .....	24
Accessories, calibration options .....	25
Measurement Accessories .....	25
Cable and adapter sets.....	25
Calibration kits .....	26
For devices with 1.85 mm connectors.....	27
For devices with 2.4 mm connectors.....	28
For devices with K connectors (2.92 mm) .....	30
For devices with 3.5 mm or SMA connectors.....	31
For devices with Type-N connectors .....	37
For devices with 7 mm connectors .....	42
For devices with waveguide .....	42
Verification kits.....	44
Accessories .....	45
Upgrade Your System .....	45
E5080B and E5071C Comparison .....	46
Literature Information.....	47
Web Resources .....	47

## E5080B ENA Series Vector Network Analyzer Configurations

This configuration guide describes standard configurations, options, accessories, upgrade kits and compatible peripherals for the Keysight E5080B ENA Series vector network analyzer (VNA). All documentation of the E5080B is available on the product page at: [www.keysight.com/find/e5080b](http://www.keysight.com/find/e5080b)

### Test set options

Choose one of the frequencies and test set options for the E5080B. Option 2xx indicates two test ports and option 4xx indicates four test ports. To add options to a product, order the corresponding item number (E5080B-xxx).

Option number	Description	Test port connectors
<b>2-port Options</b>		
E5080B-240	2-port test set, 9 kHz to 4.5 GHz	Type-N (f)
E5080B-260	2-port test set, 9 kHz to 6.5 GHz	Type-N (f)
E5080B-290	2-port test set, 9 kHz to 9 GHz	Type-N (f)
E5080B-2D0	2-port test set, 9 kHz to 14 GHz	Type-N (f), 3.5 mm (m)
E5080B-2H0	2-port test set, 9 kHz to 18 GHz	Type-N (f), 3.5 mm (m)
E5080B-2K0	2-port test set, 9 kHz to 20 GHz	3.5 mm (m)
E5080B-2L0	2-port test set, 100 kHz to 26.5 GHz	3.5 mm (m)
E5080B-2M0	2-port test set, 100 kHz to 32 GHz	2.4 mm (m)
E5080B-2N0	2-port test set, 100 kHz to 44 GHz	2.4 mm (m)
E5080B-2P0	2-port test set, 100 kHz to 53 GHz <sup>1</sup>	1.85 mm (m)
<b>4-port Options</b>		
E5080B-440	4-port test set, 9 kHz to 4.5 GHz	Type-N (f)
E5080B-460	4-port test set, 9 kHz to 6.5 GHz	Type-N (f)
E5080B-490	4-port test set, 9 kHz to 9 GHz	Type-N (f)
E5080B-4D0	4-port test set, 9 kHz to 14 GHz	Type-N (f), 3.5 mm (m)
E5080B-4H0	4-port test set, 9 kHz to 18 GHz	Type-N (f), 3.5 mm (m)
E5080B-4K0	4-port test set, 9 kHz to 20 GHz	3.5 mm (m)
E5080B-4L0	4-port test set, 100 kHz to 26.5 GHz	3.5 mm (m)
E5080B-4M0	4-port test set, 100 kHz to 32 GHz	2.4 mm (m)
E5080B-4N0	4-port test set, 100 kHz to 44 GHz	2.4 mm (m)
E5080B-4P0	4-port test set, 100 kHz to 53 GHz <sup>1</sup>	1.85 mm (m)
<b>4-port Options with internal second source</b>		
E5080B-442	4-port test set, 9 kHz to 4.5 GHz with second source	Type-N (f)
E5080B-462	4-port test set, 9 kHz to 6.5 GHz with second source	Type-N (f)
E5080B-492	4-port test set, 9 kHz to 9 GHz with second source	Type-N (f)
E5080B-4D2	4-port test set, 9 kHz to 14 GHz with second source	Type-N (f), 3.5 mm (m)
E5080B-4H2	4-port test set, 9 kHz to 18 GHz with second source	Type-N (f), 3.5 mm (m)
E5080B-4K2	4-port test set, 9 kHz to 20 GHz with second source	3.5 mm (m)
E5080B-4L2	4-port test set, 100 kHz to 26.5 GHz with second source	3.5 mm (m)
E5080B-4M2	4-port test set, 100 kHz to 32 GHz with second source	2.4 mm (m)
E5080B-4N2	4-port test set, 100 kHz to 44 GHz with second source	2.4 mm (m)
E5080B-4P2	4-port test set, 100 kHz to 53 GHz with second source <sup>1</sup>	1.85 mm (m)

1. Frequency is settable up to 54 GHz.

## Spectrum analysis hardware options

Choose one of spectrum analysis hardware to the E5080B (Option 09x). The frequency of Option 09x must match with the operation frequency of test set options. S96090B application software is required for spectrum analysis using the Option 09x.

Option number	Description	Additional information
E5080B-090	Spectrum analysis hardware, 9 kHz to 4.5 GHz	
E5080B-091	Spectrum analysis hardware, 9 kHz to 6.5 GHz	
E5080B-092	Spectrum analysis hardware, 9 kHz to 9 GHz	
E5080B-093	Spectrum analysis hardware, 9 kHz to 14 GHz	
E5080B-094 <sup>1</sup>	Spectrum analysis hardware, 9 kHz to 20 GHz	
E5080B-095	Spectrum analysis hardware, 100 kHz to 26.5 GHz	
E5080B-096	Spectrum analysis hardware, 100 kHz to 32 GHz	
E5080B-097	Spectrum analysis hardware, 100 kHz to 44 GHz	
E5080B-098	Spectrum analysis hardware, 100 kHz to 53 GHz	

1. Order Option 094 for 18 GHz options (opt.2H0/4H0/4H2). The maximum frequency of spectrum analysis is limited at 18 GHz.

## Internal bias tees options

Choose one of internal bias tees options.<sup>1</sup>

Option number	Description	Additional information
E5080B-120	Add internal bias tees for 2-port E5080B	Available with 4.5/6.5/9/14/20 GHz options only
E5080B-140	Add internal bias tees for 4-port E5080B	Available with 4.5/6.5/9/14/20 GHz options only

1. Internal bias tees options cannot be combined with 14 or 18 GHz options with Type-N connectors.

## Hardware options

Option number	Description	Additional information
E5080B-021	Add pulse modulator to internal 1 <sup>st</sup> source	This option adds the internal pulse modulators on the analyzer's source. On the single source models, the pulse modulation works at port 1 and 2 (on 2-port models) and at all four ports (on 4-port models). On the second source models, opt. 021 pulse modulation works only for the port 1 and 2. S96025B application software is required for pulsed-RF measurements.
E5080B-022	Add pulse modulator to internal 2 <sup>nd</sup> source	This option adds the internal pulse modulators on the analyzer's source. This option is available only on the second source models (opt. 4x2) and pulse modulation works for the port 3 and 4. S96025B application software is required for pulsed-RF measurements.
E5080B-1E5	Add high stability time base	Adds higher stability time base reference.
E5080B-1NC	Equipped with Type-N connectors	Adds Type-N connectors for 14 and 18 GHz options (opt.2D0/4D0/4D2/2H0/4H0/4H2). Can not be combined with internal bias tees options (opt.120 or 140).
E5080B-172	Add GPIB interface	
E5080B-175	Add analog input and output	Provides two DC sources and four input ports for DC measurements.

## Application software

Model number <sup>1</sup>	Description	Additional information
S96007B	Automatic fixture removal	
S96010B	Time domain analysis	
S96011B	Enhanced time domain analysis with TDR	Includes all capabilities of S96010B
S96015B	Real-time S-parameter and power measurement uncertainty	Displays the measurement uncertainty dynamically (real-time) on the measurement trace.
S96025B	Basic pulsed-RF measurements	Requires hardware option 021 at least.
S96029B <sup>2</sup>	Noise figure measurements with vector correction	Standard receivers are used.
S96041B	Impedance analysis	Provides impedance analysis of small-sized surface mount devices (SMD) up to 10 GHz. Requires 16198A option 010 test fixture <sup>3</sup> and 85052DH02 mechanical cal kit.
S96082B <sup>2</sup>	Scalar mixer/converter measurements	Provides SMC measurement class.
S96083B <sup>2</sup>	Vector and scalar mixer/converter measurements	Provides SMC + phase measurement class. Provides vector mixer characterization.
S96084B <sup>2</sup>	Embedded-LO capability	
S96086B <sup>2</sup>	Gain-compression measurements	
S96087B <sup>2,4</sup>	Intermodulation distortion measurements	Requires option 4x0 or 4x2 (4-port E5080B).
S96088B	Source phase control	Requires option 4x2 (internal second source option).
S96089B <sup>2</sup>	Differential and I/Q device measurements	Requires option 4x2 (internal second source option).
S96460B	True-mode stimulus	Requires option 4x2 (internal second source option).
S96090B <sup>2</sup>	Spectrum analysis	Requires hardware option 09x.
S96552B	Multiport calibration assistant	Provides a tool to flexibly define cal sets of multiport measurements. Requires one ECal module.
S94050B	Vector network analyzer (VNA) simulator – Standard	Runs on your PC and simulates standard S-parameter measurement class of Keysight's VNAs.
S94051B	Vector network analyzer (VNA) simulator - Advanced	Runs on your PC and simulates VNA functions including advanced features of S96xxxB software <sup>5</sup> .
S94601B	Device measurement expert (DMX)	Assists the users in setting up measurements automatically with customizable templates.
S94602B	Limit assistant	Allows to acquire the data from the VNA, and easily generate limit masks for production tests.
S94701A S94702A KS8400A	Automated measurement expert (AMX)	A smart software solution for automated multiport S-parameter measurements with the E5080B and E5092A <sup>6</sup> . Order each software model and install in a PC or the analyzer.
S94USBCB <sup>7,8</sup>	USB Type-C interconnects compliance test software	Performs automated compliance tests of USB Type-C interconnects (ex. cable assemblies, connectors, or raw cables) using 4-port E5080B.

1. The S96xxxB software has six license types, please refer to "Keysight Software Licensing Options Provide Flexibility and Support" for more detail.
2. Provides frequency offset mode (FOM) to independently set the frequency of internal source(s) and receivers, and to configure external sources using External Device Configuration.
3. The 16198A option 010 is connected with the E5080B's options up to 20 GHz with either Type-N or 3.5-mm connectors. It offers optional fixtures to mount 0402 mm (0402 mm / 01005 inch) and 0201 (0201 mm / 008005 inch) devices with option 200 and 100 respectively.

4. S96087B requires a direct receiver access (DRA) configuration using a 4-port E5080B. Additionally, an external source, a dual directional coupler, and a combiner are required.
5. Features of S96007B and S96552B are not supported with the S94051B.
6. A 4-port ECal module (ex. N4431D or N4433D) is recommended for multiport measurements.
7. Requires S96011B, KS8400B PathWave Test Automation, and KS8104B HTML5 Result Listener Plugin.
8. Supports L8990M-0LZ 20-port switch matrix to configure a multiport test system which eliminates the need for reconnections of test cables with DUT.

## Calibration options

Option number	Description	Additional information
E5080B-1A7	ISO 17025 compliant calibration	
E5080B-A6J	ANSI Z540 compliant calibration	

## Accessories

Option number	Description	Additional information
E5080B-1CM	Rack mount kit for installation without handles	Adds a rackmount flange kit (5063-1543) and a rail kit (E3663AC) for use without handles.
E5080B-1CP	Rack mount kit for installation with handles	Adds handles, a rack mount flange kit (5063-1555), and a rail kit (E3663AC) for use with handles.
E5080B-181	Add keyboard	
E5080B-182	Add mouse	



# E5080B Test set options and Block Diagrams

## E5080B Option 240/260/290/2D0/2K0 (2-port base options)

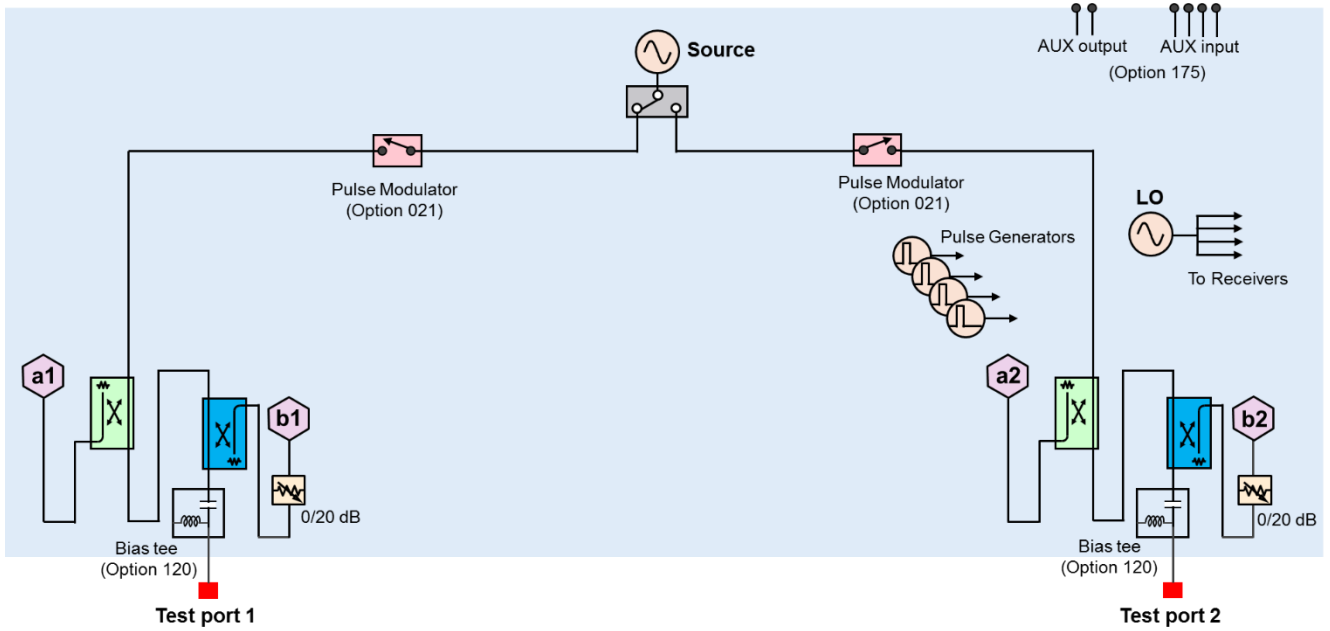

## E5080B Option 2L0/2M0/2N0/2P0 (2-port base options)

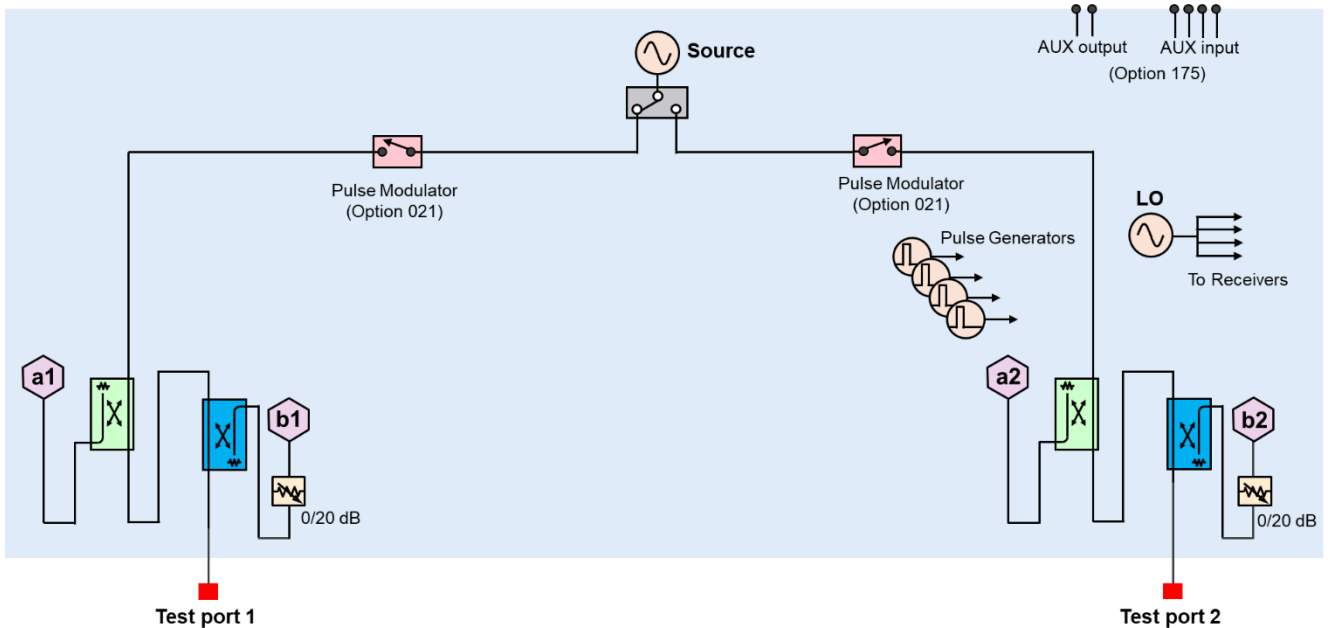

## E5808B Option 440/460/490/4D0/4K0 (4-port base options)

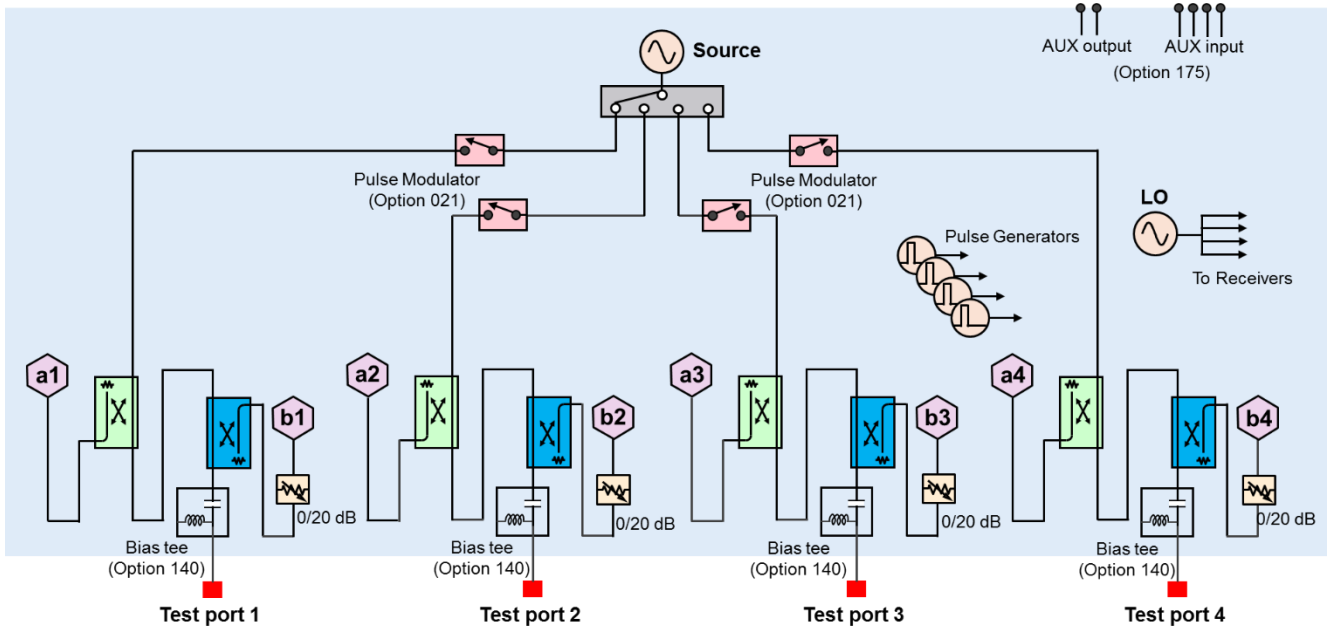

## E5808B Option 4L0/4M0/4N0/4P0 (4-port base options)

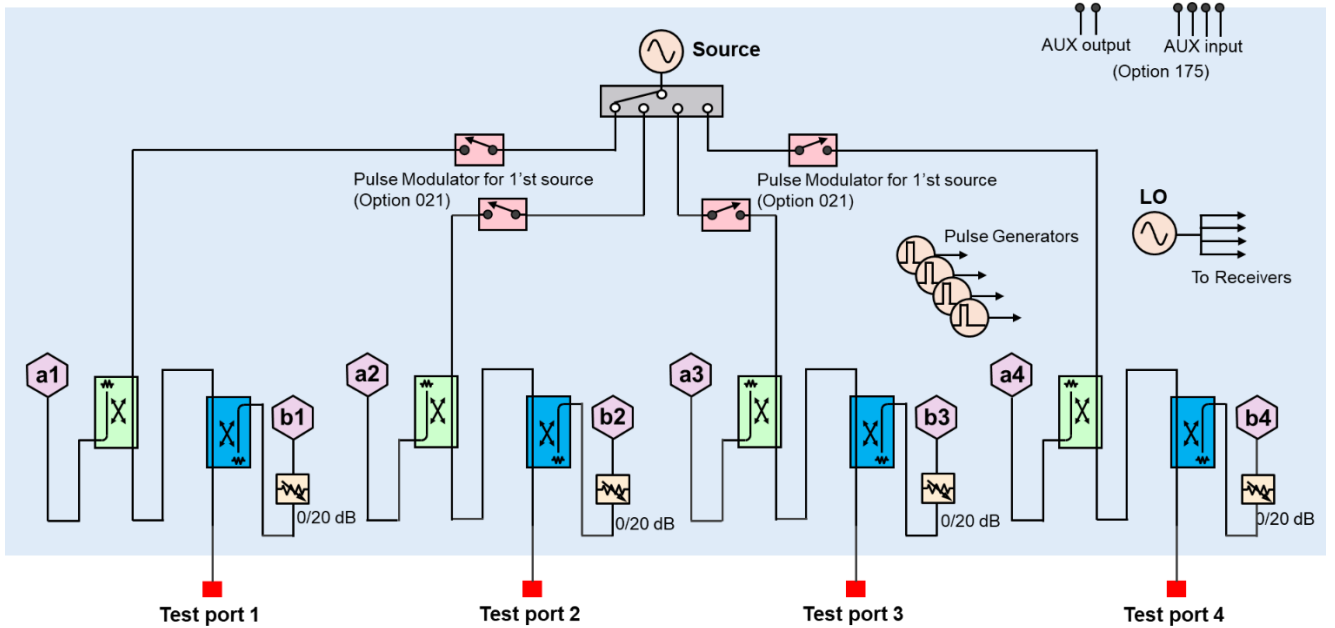

E5080B Option 442/462/492/4D2/4K2 (4-port second source option)

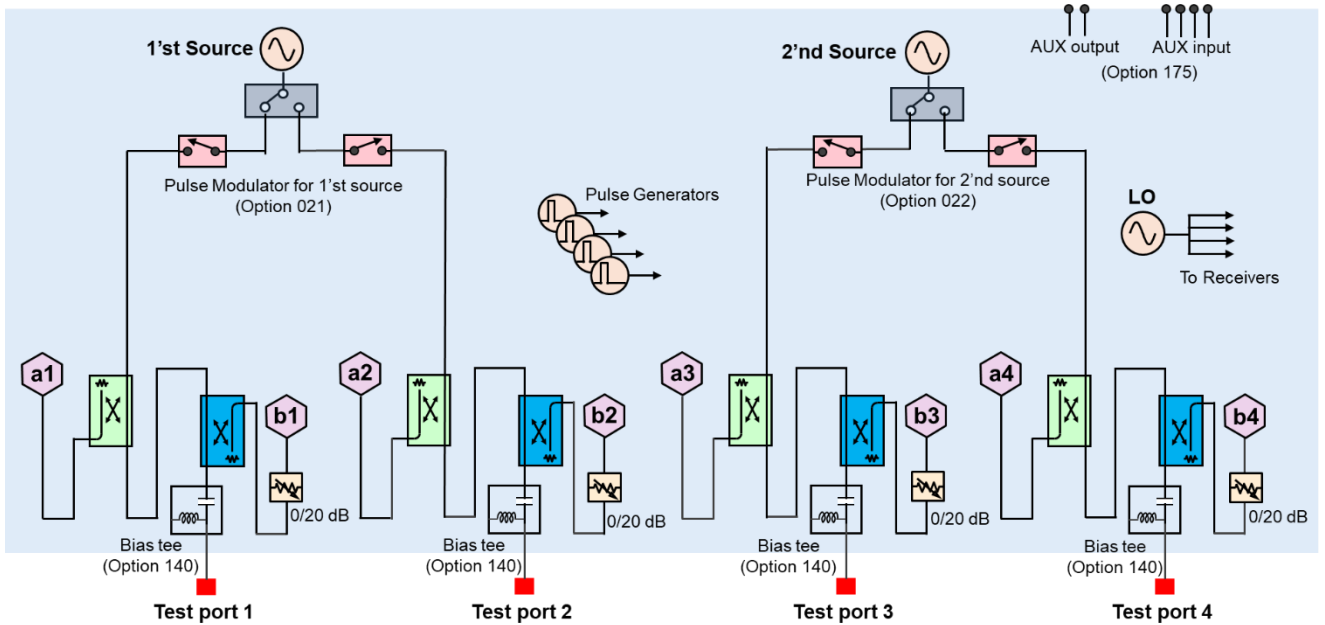

E5080B Option 4L2/4M2/4N2/4P2 (4-port second source options)

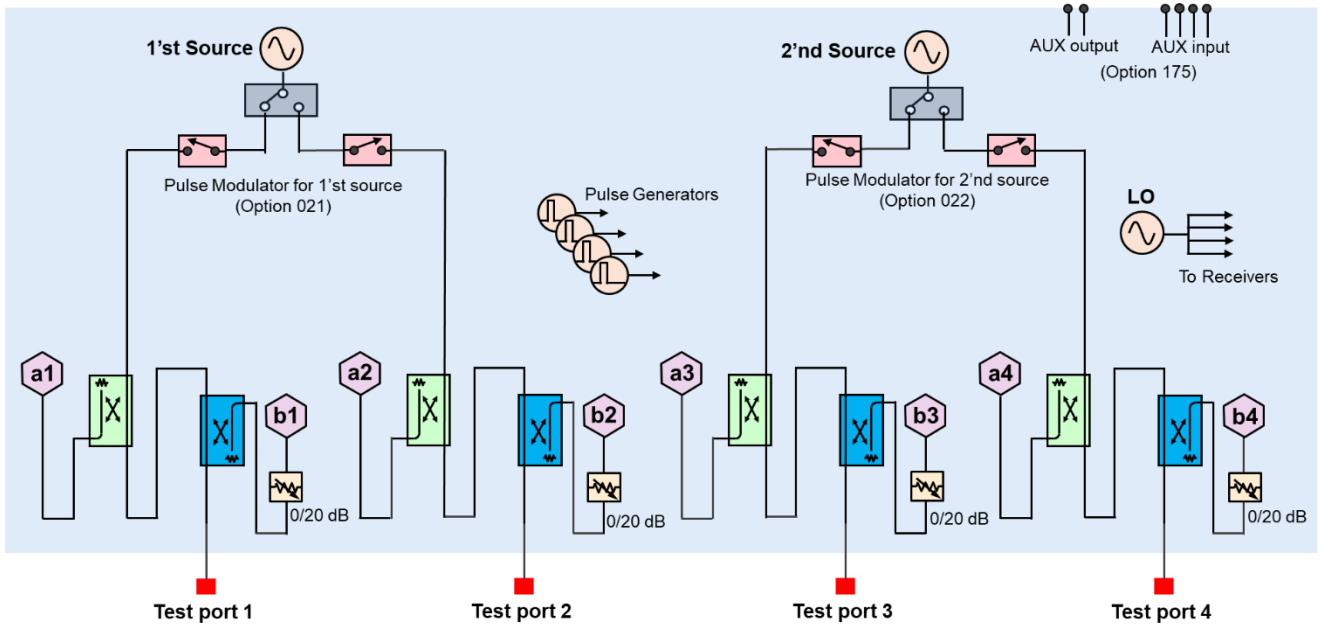

## Measurement Application Software

### Automatic fixture removal (S96007B)

Many devices do not have coaxial connectors and are put in fixtures in order to measure them in a coaxial environment. Accurately removing the effects of the fixture is required to get a good measurement of the device under test (DUT). This application adds a powerful application wizard to guide you through characterizing a fixture and removing it from the measurement. Devices can be single-ended or differential. Files can be saved in a variety of formats for later use in ENA, PNA, PXI VNA, Streamline Series VNA, ADS, and PLTS.

### Time domain analysis (S96010B)

This application enables the analyzer to view reflection and transmission responses in time or distance. Use time domain to tune filters, gate out the response of fixtures and cables, characterize the impedance of transmission lines and more.

### Enhanced time domain analysis with TDR (S96011B)

This application enables the analyzer to perform enhanced time domain analysis for high-speed data applications. All functionalities of the S96010B are included (TDR/TDT mode). In addition, the S96011B enables more detailed measurements and evaluations, such as eye-diagram/mask modes, without adding PLTS software. Jitters and/or emphasis/equalization capabilities enables simulation of real-world signals and environment. S96011B covers up to 53 GHz bandwidth with 8.42 psec rise time. Full calibration is available and the automatic deskew ensures easy removal of fixture and probe effects. To get the best accuracy, mechanical calibration kits or ECal with DC option (ex. N443xD or N469xD with Option 0DC) are recommended.

### Real time S-parameter and power measurement uncertainty (S96015B)

This application provides uncertainties for both S-parameter and power measurements on the E5080B. The real-time display of the uncertainty associated with power and S-parameter traces increases the confidence in the reproducibility of measurements. This allows users to implement pass/fail tests easily because now the instrument quantifies the gray region that is in between a full pass or a full fail, apply more realistic limit lines which can increase the production yield and reduce the defect percentage on the finished products. This application easily establishes a metric to quantify the quality of the measurement process, so your company's quality control procedures are simplified. It includes the uncertainty information for most Keysight calibration kits and provides national metrology institute traceability through Keysight's calibration kits. This application also helps you to include uncertainty information for your product's specifications and data sheets.

## Basic pulsed-RF measurements (S96025B)

This application enables internal pulse generators that can be used to control the internal pulse modulators, and it provides an integrated pulse application that uses the wideband-detection method. The software requires hardware option 021 or 022 pulse modulator hardware.

The pulse application provides an easy way to set up point-in-pulse measurements with pulse width as narrow as 1 us, and pulse-profile measurements with 40 ns minimum timing resolution. Using the built-in pulse modulators, the E5080B is a complete pulsed-RF measurement solution, eliminating the need for external test sets and pulse generators. S96025B also controls external pulse generators and modulators and can synchronize to external master pulses. The application I/O connector on the rear panel of the analyzer is recommended if using external master pulses or external pulse modulators.

## Noise figure measurements with vector correction (S96029B)

This software application enables high-accuracy noise figure and noise-power measurements of amplifiers, frequency converters, and mixers, utilizing Keysight's unique vector-source-correction technique that uses Keysight N469xD series ECal module as a source-impedance tuner<sup>1</sup> to remove the effects of imperfect system-source match. This approach yields accuracy that surpasses that provided by the Y-factor method and other cold-source implementations, especially for in-fixture, on-wafer, and automated-test environments. S96029B controls N469xD Series ECal modules configured as impedance tuners for use with the E5080B. A scalar-calibrated method is also available that offers less accuracy but is faster and does not require an impedance tuner. This method requires an external switch to isolate the E5080B's source signal during noise figure measurements. A 50-ohm load must be connected to the DUT's input using the switch.

The analyzer's standard receivers are used for noise figure measurements with the S96029B. An external preamplifier, filter(s) and switches are required for devices with < 30 dB of excess noise (gain plus noise figure in dB). A typical block diagram of vector-calibrated noise figure measurements is shown.

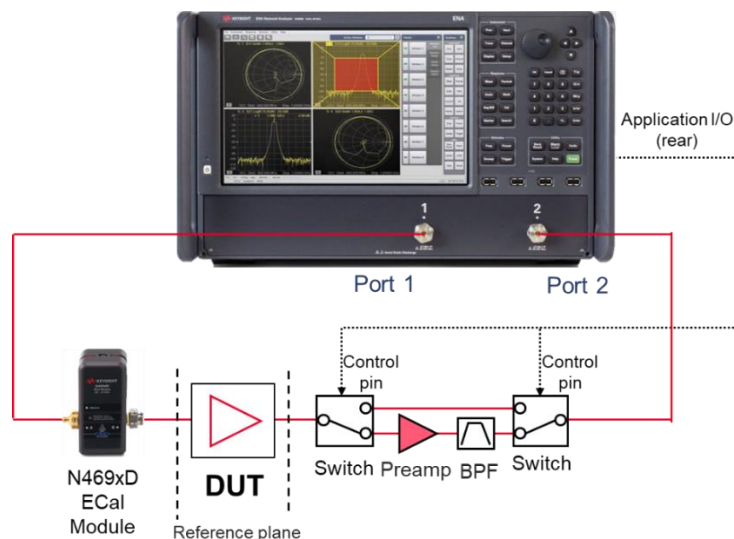

1. 8509x, N443x or N755xA Series ECal modules are not supported.

For calibration, a standard mechanical cal kit or ECal module is required for the S-parameter portion of the cal (an ECal used as a tuner cannot be shared for calibration). To calibrate a standard receiver for noise figure measurements, a power meter is required. All calibration accessories and external hardware must be ordered separately.

Noise figure measurements with the E5080B are verified between 50 MHz and 45 GHz.

### Impedance analysis (S96041B)

This software application enables the E5080B to measure impedance parameters of surface mount devices (SMDs) such as capacitors or inductors up to 10 GHz. The high-frequency impedance analysis solution consists of E5080B, S96041B and 16198A test fixture with option 010 to mount a small-sized SMD under test, with either 0402 mm (01005 inch) or 0201 mm (008004 inch) size. S96041B computes impedance parameters from measured data of E5080B using the 1-port reflection measurement method.

For calibration, S96041B provides two-step calibration for accurate impedance measurements – full 1-port calibration and enhanced fixture compensation. The 85052DH02 data-based calibration kit is required to perform full 1-port calibration to define the calibration plane at the 3.5-mm coaxial connector of 16198A's adapter. Then, fixture effects are removed with the special compensation method. Open/short fixture compensation eliminates the effects of residual impedance and stray admittance around the fixture's electrodes. The whole calibration process eliminates system errors associated with cables and test fixture and delivers accurate impedance measurements.

### Scalar mixer/converter measurements (S96082B)

S96082B provides frequency offset mode (FOM) to set the frequency of the internal source(s) independently from where the receivers are tuned, and to configure external sources using External Device Configuration. This functionality is also included with S96029/083/084/086/089/090, both B and A models.

With a simple setup and calibration, this application delivers the highest accuracy for scalar conversion-loss/gain measurements by combining one-port and power-meter calibrations to remove mismatch errors. S96082B provides an intuitive and easy-to-use user interface for setting up mixer and converter measurements, with single or dual conversion stages. It can control external signal generators for use as LO signals. Supported external sources include the Keysight ESG, PSG, EXG, and MXG Series, as well as other SCPI-controlled signal generators.

S96082B is compatible with S96084B, which enables measurements of converters with internal LOs.

### Vector and scalar mixer/converter measurements (S96083B)

This application includes the scalar mixer/converter plus phase (SMC+Phase) measurement class that provides fully calibrated conversion gain/loss, relative phase, and absolute group delay measurements of mixers and converters without the need for reference or calibration mixers. Eliminating the calibration mixer requires a U9391C/F/G comb generator<sup>1</sup> and an external DC power supply capable of sourcing +15 V and 300 mA for U9391C/F or 800 mA for U9391G. A vector mixer characterization (VMC) is also

included for measuring group delay of frequency converting devices. VMC is used to characterize a calibration mixer supplied by the user.

SMC+Phase with the S96083B provides an intuitive and easy-to-use user interface for setting up mixer and converter measurements, with single or dual conversion stages. It can control the analyzer's built-in source(s) as well as external signal generators for use as LO signals. Supported external sources include the Keysight ESG, PSG, EXG, and MXG Series, as well as other SCPI-controlled signal generators. S96083B is a superset of S96082B, so they should not be installed together. S96083B is compatible with S96084B, which enables measurements of converters with internal LOs.

1. When a comb generator is used as a phase reference for calibration and the start frequency of the measurement is less than 630 MHz, a user-supplied calibration mixer is required.

### Embedded LO capability (S96084B)

This application tunes the analyzer's receivers to the output frequency of the converter under test without the need for access to internal LOs or a common reference signal. S96084B is intended to work with S96082B and S96083B measurement applications.

### Gain compression measurements (S96086B)

The gain compression application (GCA) provides input power, output power, gain, and phase at the compression point of an amplifier or frequency converters, over a specified frequency range. GCA's SMART Sweep is very fast and easy-to-use. GCA also includes a guided calibration that corrects for absolute power levels, frequency response, and mismatch errors.

### Intermodulation distortion measurements (S96087B)

The intermodulation distortion (IMD) application makes it very easy to set up and calibrate swept-IMD measurements of both amplifiers and frequency converters. It controls the frequency and power of internal and external sources and tunes the receivers to the main tones as well as the IMD products in a single measurement channel. You can sweep either the center frequency of the two stimulus signals, the frequency spacing of the two stimulus signals about a fixed center frequency, the power of one or both stimulus signals, or the power of the LO signal.

The analyzer can measure intermodulation distortion products of order 2, 3, 5, 7, or 9, and display the associated intercept points. S96087B requires the use of the Direct Receiver Access (DRA) configuration using a 4-port E5080B. Additionally, an external source, dual directional coupler, and an external combiner are required.

### Source phase control (S96088B)

This application allows users to set calibrated, arbitrary phase differences between two internal sources with the E5080B's option 4x2. The phase difference can be fixed or swept between two specified phase values. S96088B also controls the relative power level between the sources using the receiver-leveling feature. S96088B is targeted for active-load control, where the analyzer provides a precise,

electronically settable impedance to the output port of a device, while gain and output power are measured. This capability can be combined with external load-pull software to create traditional load-pull power contours. Not available with the E5080B option 2x0 or 4x0 with a single internal source.

### Differential and I/Q device measurements (S96089B)

This application combines source-phase control of multiple internal or external sources with frequency-offset mode, enabling simplified test of I/Q modulators/converters and differential mixers, and harmonic measurements of differential amplifiers. The phase difference between sources can be fixed (for example, at 90 or 180 degrees), or swept between two specified phase values. Providing accurate control of the relative phase between sources eliminates the need for hybrid couplers and baluns to create quadrature or differential signals. After achieving the desired phase alignment, the instrument's receivers can be tuned to all frequencies needed to characterize the DUT. On an I/Q modulator for example, measurements can be made of both the desired and suppressed conversion bands, along with LO leakage, harmonics and other spurious signals. Phase sweeps can be used to determine a DUT's phase imbalance versus frequency. Users can specify measurements with individual receivers or multiple receivers combined with a wide range of mathematical operators. Power measurements can employ match correction for increased accuracy. S96089B only works on the E5080B with option 4x2 (internal second source option).

### Spectrum analysis (S96090B)

The spectrum analyzer (SA) application adds high-performance microwave spectrum analysis to the analyzer. With fast stepped-FFT sweeps resulting from optimized data processing, the SA application provides quick spurious searches over broad frequency ranges. Simultaneous spectrum measurements can be done using test and reference receivers. This multi-channel SA can be used with the internal swept-signal generators for efficient measurements of spurious signals emanating from mixers and frequency converters. The SA application employs source-power and receiver-response calibration as well as fixture de-embedding, providing in-fixture and on-wafer spectrum measurements with the highest level of accuracy. Accurate and fast noise power ratio (NPR) measurement capability is also included in this software application. It provides the ability of setting up and controlling of external signal generator/arbitrary waveform generators and performing the calibration of the flatness of a wideband signal and distortion signals in notches and achieving very fast NPR measurements. Optional external attenuators should be connected with the VNA's test ports to avoid receiver compression when measuring large signals.

S96090B software requires option 09x spectrum analysis hardware of the E5080B.

### True-mode stimulus (S96460B)

The application provides mismatch-corrected true-mode (true differential mode and true common mode) stimulus and enables accurate balanced measurements under real operating conditions. It also provides balanced measurements with forward-only sweeps, reverse-only sweeps, and frequency or power sweeps with arbitrary phase and amplitude offsets.

S96460B only works on the E5080B with option 4x2 (internal second source option).



## Multiport calibration assistant (S96552B)

This application software provides a tool to flexibly create and manage cal sets for multiport measurements. For example, two cal sets with independent test ports can be combined as one cal set with a greater number of test ports. The software also offers a way to re-calibrate using a certain set of test ports to refresh the cal set.

At least one ECal module is required for the operation of S96552B.

## Material measurements

The Keysight N1500A materials measurement suite streamlines the process of measuring complex permittivity and permeability with a vector network analyzer. Various type of measurements, such as transmission line and free space, arch reflectivity, resonant cavity, and coaxial probe are available as options. The easy-to-use software guides the user through setup and measurement, instantly converting S-parameter network analyzer data into the data format of your choice and displaying the results within seconds. Results can be charted in a variety of formats:  $\epsilon_r'$ ,  $\epsilon_r''$ , tand,  $\mu_r'$ ,  $\mu_r''$ , tand $\mu$ , and Cole-Cole.

## N1930xB Physical Layer Test System (PLTS) software

The PLTS software platform has become an industry standard for calibration, measurement, and analysis of linear passive interconnects such as cables, connectors, backplanes, and printed circuit boards. Utilizing either a vector network analyzer (VNA) or a time domain reflectometer (TDR), fast and accurate measurements can be obtained without in-depth knowledge of microwave measurement techniques. Refer to [www.keysight.com/find/plts](http://www.keysight.com/find/plts) or the technical overview (literature number 5989-6841EN) for more details.

## Vector Network Analyzer (VNA) simulator (S9405xB)

VNA simulator runs on your PC and simulates operations of Keysight's latest VNAs (PNA/ENA/PXI or Streamline Series VNA), eliminating the need for a VNA for your test program development. The simulator has standard and advanced versions. The standard version (S94050B) supports operations of standard S-parameter measurement class. The advanced version (S94051B) gives access to all advanced capabilities with S96xxxB software (ex. spectrum analysis) for the E5080B except S96007B or S96552B software.

S9405xB is available on subscription licenses only.

## Device Measurement eXpert (DMX) (S94601B)

S94601B assists the users in setting up measurements automatically with customizable templates to use consistent measurement settings in different stages of design and test workflow. It supports various types of DUTs, and once the right DUT is selected, appropriate measurement parameters are listed, and the users can select the parameters of interest.

It provides intelligent algorithms that optimizes measurement setups based on instrument and DUT performance limitations and protects both the DUT and the instrument.

### Limit assistant (S94602B)

S94602B allows the users to acquire the data from a VNA or data file in csv, s2p or prn format and easily generate limit masks for complex limit test conditions with an intuitive and convenient graphical interface for production test applications.

### Automated Measurement Expert (AMX)

This software package is a smart software solution for automated multiport S-parameter measurements with the 4-port E5080B and E5092A. The S94701A AMX test plan builder provides an interactive GUI which helps you edit your multiport DUT test plans and generate test sequence files for the network analyzers. The S94702A and KS8400A software running on the analyzer executes the test sequences according to the optimized test sequence files generated by the S94701A.

A 4-port ECal module (i.e. N4431D or N4433D) is recommended for calibration wizard.



Figure 1. Multiport setup using the E5092A

### USB Type-C interconnects compliance test software (S94USBCB)

This application software provides a fast and automated way to characterize and debug USB Type-C interconnect products such as cable assemblies, connectors, or raw cables on USB4, USB 3.2, USB

3.1, and USB 2.0 technologies. It allows to automatically execute compliance tests with a 4-port VNA based on the latest USB Type-C Compliance Test Specification (CTS) by USB-IF, and displays the comprehensive test results including test limits, margins, and pass/fail status of each test parameter.

S94USBCB supports multipoint configurations using a 4-port VNA and L8990M-0LZ (e.g. 20-port switch matrix), which fully automates the test procedure and dramatically reduces the test time by eliminating manual cable reconnections.

S94USBCB requires S96011B, KS8400B PathWave Test Automation and KS8401B HTML5 Result Listener Plugin.

Refer to [www.keysight.com/find/S94USBCB](http://www.keysight.com/find/S94USBCB) or S94USBCB USB Type-C Interconnects Compliance Software data sheet (literature number [3122-1253](#)) for more details.

## E5080B Hardware Configurations

### Pulse modulation hardware (Option 021)

Internal pulse modulator hardware on Source 1. On the single source options, the pulse modulation works for the port 1 and 2 (on Option 2x0 2 port models) and all four ports (on Option 4x0 4 port models). On the second source models, Option 021 pulse modulation works only for the port 1 and 2. The modulators can be controlled via the Application I/O D-sub connector on the rear panel of the analyzer using an external pulse generator, or by using one of the internal pulse generators. S96025B is required to enable the internal pulse modulators.

### Pulse modulation hardware (Option 022)

Internal pulse modulator hardware on Source 2 on the second source options (Option 4x2). Option 022 pulse modulation works for the port 3 and 4. The modulators can be controlled via the Application I/O D-sub connector on the rear panel of the analyzer using an external pulse generator, or by using one of the internal pulse generators. S96025B is required to enable the internal pulse modulators.

### High stability time base (Option 1E5)

The option improves specification of frequency accuracy within  $\pm 0.45$  ppm.

### Internal bias tees (Option 120 or 140)

Broadband internal bias tees are integrated for each test port with Option 120 or 140. Order Option 120 for 2-port options and order Option 140 for 4-port options. DC power can be provided via BNC female connectors on the rear panel of the analyzer for the operation of active components under test such as tower mounted amplifiers (TMAs). Internal bias tees are available on the models with the highest frequency is equal or lower than 20 GHz.

## Analog input and output (Option 175)

The E5080B Option 175 adds analog input and output ports with BNC female connectors on the rear panel of the analyzer to enable DC measurements with the E5080B. Two integrated variable DC sources provide  $\pm 10$  VDC with maximum current of 200 mA. Synchronized DC voltage sweep is performed using the E5080B's firmware.

For more comprehensive analysis, four analog inputs with BNC female connectors are provided to allow sensing of DC voltages from the DUT.

## Device Test I/O

Device test I/O with a 25-pin D-sub connector on the rear panel of the analyzer allows users to control the device under test (DUT) directly with serial or parallel digital interface. Signals from the I/O are applied to select operation modes of the RF front-end module which integrates power amplifiers, switches, low noise amplifiers, duplexers or filters in a single component.

The device test I/O has two independent 8-bit digital I/Os (DIOs). Each 8-bit DIO can provide either 8-bit parallel signals or 4-channels of RFFE-like interface. Output DC voltage or clock rate (25 MHz maximum) are selectable according to the specification of DUTs.

Quick and easy setup of DUT control signals can be done with the E5080B's firmware, and the operation of the device test I/O is synchronized with the measurement sweep of the analyzer.

## Application I/O

Application I/O with a 15-pin D-sub connector on the rear panel of the analyzer provides required signals for synchronized measurements using the E5080B and external peripherals such as pulse generators, pulse modulators, RF switches for NF measurements, or signal generators.

N1966A pulse I/O adapter is recommended if using an external pulse generator. N1966A enables coaxial connections between the Application I/O D-sub connector on the rear panel of the analyzer and the coaxial inputs and outputs of external pulse generators and external pulse modulators. Coaxial connectors are SMB male. A connector saver (P/N: Z2342-37605) and hex standoff (P/N: 0380-5625) are required for the connection of the E5080B and N1966A.

## Direct Receiver Access (DRA) Configurations

The 4-port E5080B supports direct receiver access (DRA) configurations to flexibly set up test systems with optimized performance by integrating with external components<sup>1</sup> such as booster amplifiers, attenuators, or directional couplers. This function (included in the VNA firmware) combines three physical test ports of the E5080B and defines them as a single logical port. You can perform measurements including calibration and post processing using the logical ports.

### DRA configuration with high-power

One example using the DRA configuration is S-parameter measurements with high power. When you need an input level higher than the analyzer's source can provide, pre-amplifiers are necessary to boost the power level prior to the DUT. However, the reference signal is measured before the booster amplifier with a standard configuration of a 2-port VNA, and temperature drift or high reverse isolation of a booster amplifier will prevent accurate reflection measurements of the DUT's input.

A typical configuration for high-power measurements with the 4-port E5080B is shown. Reflected and transmitted signals of the DUT are detected with all the logical receivers, and the VNA firmware provides measured high-power S-parameters.

Physical port  
(Logical or DRA port)

$$\begin{aligned} S_{11} &= b_1/a_1 \\ S_{21} &= b_2/a_1 \\ S_{12} &= b_1/a_2 \\ S_{22} &= b_2/a_2 \end{aligned}$$

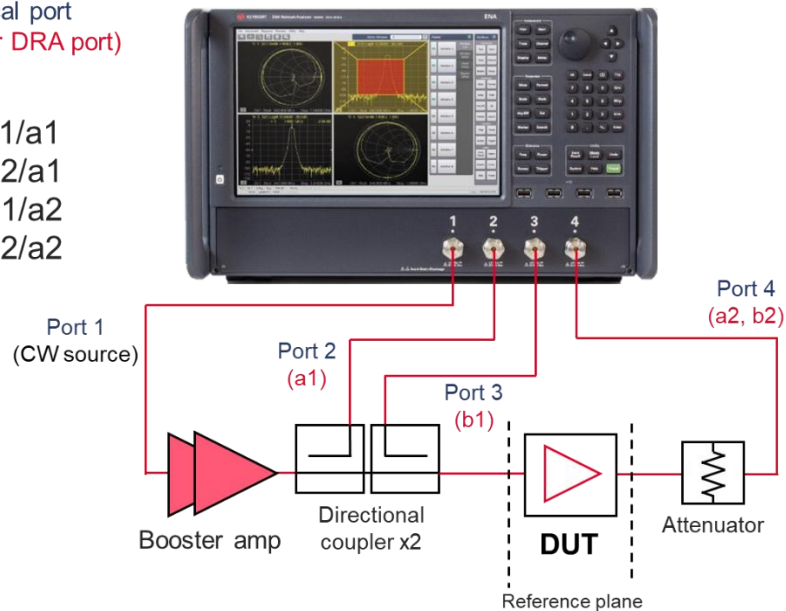

External components should be selected based on their high-power limits or frequency range specifications. Be sure that these components can handle the output power level of the booster amplifier.

1. External components are not included in the E5080B. Must be purchased separately.

## Keysight Software Licensing Options Provide Flexibility and Support

Projects ramp up and down, teams grow and shrink, and projects move location. In such a dynamic environment, you need flexible licensing options that allow you to balance your project's requirements. Whether your software will be a staple for years to come or you have a short-term need for a leading-edge measurement application, Keysight's licensing puts you in charge.

### Choose your term. Choose your type. Keep control of your budget.

- Select a node-locked, transportable, USB portable or floating license type, depending on how much flexibility you need.
- Select a subscription or perpetual license term, depending on how long you need to use the software.
- Each license is sold with a KeysightCare software support subscription which provides technical support with ensured response time, proactive software updates and enhancements.

Choose a license term and type that best suits your requirements from the table below.

#### License term

License term	Descriptions
Perpetual	Perpetual licenses can be used indefinitely.
Subscription	Licenses can be used through the term of the subscription (6, 12, 24, or 36 month)

#### License type

License type	Descriptions
Node locked	License can be used on one specified instrument/computer.
Transportable	License can be used on one instrument/computer at a time but may be transferred to another using Keysight Software Manager (internet connection required).
USB portable	License can be used on one instrument/computer at a time but can be transferred to another using a certified USB dongle (available for additional purchase, Keysight part number E8900-D10).
Floating	Networked instruments/computers can access a license from a server one at a time. Multiple licenses may be purchased for concurrent usage. Three types of floating license are available: Single Site: 1-mile radius from the server Single Region <sup>1</sup> : Americas, Europe, Asia Worldwide (export restriction identified in End User License Agreement (EULA))

1. Americas (North, Central, and South America, Canada); Europe (European Continent, Middle Eastern Europe, Africa, India); Asia (North and South Asia Pacific Countries, China, Taiwan, Japan).

## KeysightCare Software Support Subscription provides peace of mind amid evolving technologies.

- Ensure your software is always current with the latest enhancements and measurement standards.
- Gain additional insight into your measurement problems with live access to our team of technical experts.
- Stay on schedule with fast turnaround times and priority escalations when you need support.

Subscription	Description
KeysightCare software support	Perpetual licenses are sold with a 12 (default), 24, 36, or 60-month software support subscription. Support subscriptions may be renewed for a fee after that.
	Software subscription licenses include a software support subscription through the term of the license.

## Ordering Information

- Step 1. Choose your software product.
- Step 2. Choose your license term: perpetual or subscription.
- Step 3. Choose your license type: node-locked, transportable, USB portable, or floating.
- Step 4. Depending on the license term, choose your subscription or support duration.

Product	License type	License term			
		Perpetual		Subscription	
S96xxxB		License		Support	License and support
	Node-locked (fixed)	R-A5B-001-A	+	R-A6B-001-z	R-A4B-001-z
	Transportable	R-A5B-004-D	+	R-A6B-004-z	R-A4B-004-z
	USB portable <sup>1</sup>	R-A5B-005-E	+	R-A6B-005-z	R-A4B-005-z
	Floating (single site)	R-A5B-002-B	+	R-A6B-002-z	R-A4B-002-z
	Floating (single region)	R-A5B-006-F	+	R-A6B-006-z	R-A4B-006-z
	Floating (worldwide)	R-A5B-010-J	+	R-A6B-010-z	R-A4B-010-z
				z = Duration	z = Duration
				L 12 months (default) <sup>2</sup>	F 6 months
				X 24 months	L 12 months
				Y 36 months	X 24 months
				Z 60 months	Y 36 months

1. USB portable license requires a certified USB dongle (available for additional purchase, Keysight part number E8900-D10).
2. For S96xxxB software, the fixed-perpetual with a 12-months, support subscription (R-A6B-001-L) is the only license type that can be ordered as part of the instrument and installed. The other license types for S96xxxB software must be ordered separately and installed from the web after the receipt of the instrument.

## E5092A Configurable Multiport Test Set

The E5092A configurable multiport test set is offered for use with the 4-port E5080B to extend the number of test ports. Multiport measurements from 50 MHz to 20 GHz can be made by connecting the optional interconnect semi-rigid cables to the E5092A's front panel.

### Test set options

Choose Option 020. Option 020 is the only test set option for the E5092A.

Option number	Description	Additional information
E5092A-020	20 GHz switching test set	Up to 22-port or 10-port full crossbar measurement.

### Cable and adapter options

Choose one of the interconnect cable and adapter set for your 4-port ENA.

Option number <sup>1</sup>	Description	Additional information
E5092A-08C	Cables and adapters for connection to E5071C Option 440/445/460/465/480/485	Adds SMA semi-rigid cables and type-N-to-SMA adapters for connection to the E5071C with type-N connectors.
E5092A-20C	Cables and adapters for connection to E5071C Option 4D5/4K5	Adds SMA semi-rigid cables and 3.5 mm-to -3.5 mm adapters for connection to the E5071C with 3.5-mm connectors.
E5092A-09A	Cable and adapters for connection to E5080A Option 445/465/495	Adds SMA semi-rigid cables and type-N-to-SMA adapters for connection to the E5080A with type-N connectors.
E5092A-09B	Cable and adapters for connection to E5080B Option 440/460/490	Adds SMA semi-rigid cables and type-N-to-SMA adapters for connection to the E5080B with type-N connectors.
E5092A-20B	Cable and adapters for connection to E5080B Option 4D0/4K0/4L0	Adds SMA semi-rigid cables and 3.5 mm-to -3.5 mm adapters for connection to the E5080B with 3.5-mm connectors.

1. E5092AU upgrade kits are available to add cable and adapter options after initial purchase. Order the corresponding item number (ex. E5092AU-09B or E5092AU-20B).

### Docking plate options

Choose option 300 for the connection of the E5080B and E5092A.

Option number <sup>1</sup>	Description	Additional information
E5092A-300	Docking plate kit for the E5080B	
E5092A-301	Docking plate kit for the E5071C	

1. E5092AU upgrade kits are available to add docking plate kit options after initial purchase. Order the corresponding item number (ex. E5092AU-300).



## Accessories, calibration options

Option number	Description	Additional information
E5092A-1CM	Rack mount kit only	Adds a rack mount kit for use without handles.
E5092A-1CN	Front handle kit only	Adds a front handle kit.
E5092A-1CP	Rack mount kit with handle kit	Adds a rack mount and front handle kit.
E5092A-1A7	ISO 17025 compliant calibration	
E5092A-A6J	ANSI Z540 compliant calibration	

## Measurement Accessories

A complete list of RF and microwave test accessories is available on our Web site:

[www.keysight.com/find/mta](http://www.keysight.com/find/mta)

Accessories are available in these connector types: 50  $\Omega$  Type-N, 3.5 mm, 7 mm, 2.4 mm, 2.92 mm, 1.85 mm, 1.0 mm, and waveguide. Test port cables and a calibration kit should be added for a complete measurement system. A verification kit is used to verify corrected system performance.

## Cable and adapter sets

Keysight offers cables in the following types:

- Single cables in semi-rigid and flexible
- Cable sets in semi-rigid and flexible

There are also adapter sets available that protect the test port and convert the port to the desired connector interface. These kits contain:

- One male adapter
- One female adapter

To attain the best mechanical rigidity for device connection, use a single cable and the appropriate special adapter set. To attain the greatest flexibility for device connection, use a cable set.

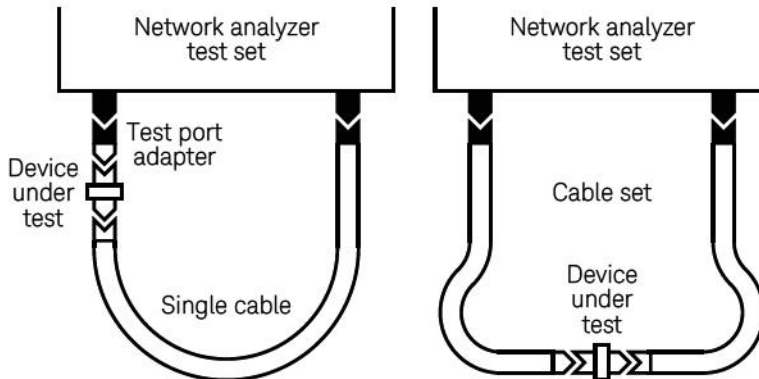

## Calibration kits

### Coaxial measurements

Mechanical calibration kits include standards, such as opens, shorts and loads, which are measured by the network analyzer for increased measurement accuracy.

Choose a calibration kit for each connector type to be used.

**Economy**, includes:

- Open standards (male and female)
- Short standards (male and female)
- Fixed-termination standards (male and female)

**Standard**, includes the devices in the economy kit and adds:

- Sliding load standards (male and female) or a series of offset shorts

**Precision**, includes the devices in the economy kit and adds:

- 50  $\Omega$  airline(s) for TRL calibration
- TRL adapters

Electronic calibration (ECal) kits replace mechanical calibration standards with one solid-state calibration module that is controlled by the network analyzer via USB, to present many different impedances to the test ports. A full two-port calibration can be performed quickly with a single connection. This technique reduces operator errors and connector wear and abrasion.

For more information about ECal modules, refer to the technical overview 5963-3743E (N4690, 85090, N4430 and N7550 Series).

## Waveguide measurements

For waveguide measurements, Keysight offers mechanical calibration kits that include:

- Waveguide-to-coax adapters (X, P, K, R, Q, U, V)
- Precision waveguide section
- Flush short circuit
- Fixed terminations
- Straight section

## For devices with 1.85 mm connectors

### Mechanical calibration kit

85058B standard: DC to 67 GHz. Includes:

- 85058-60101 1.85 mm (m) short 5.4 mm
- 85058-60102 1.85 mm (m) short 6.3 mm
- 85058-60103 1.85 mm (m) short 7.12 mm
- 85058-60104 1.85 mm (m) short 7.6 mm
- 85058-60105 1.85 mm (f) short 5.4 mm
- 85058-60106 1.85 mm (f) short 6.3 mm
- 85058-60107 1.85 mm (f) short 7.12 mm
- 85058-60108 1.85 mm (f) short 7.6 mm
- 85058-60109 1.85 mm male open
- 85058-60110 1.85 mm female open
- 85058-60111 1.85 mm male load
- 85058-60112 1.85 mm female load
- 85058-60113 1.85 mm (m) to 1.85 mm (m) adapter
- 85058-60114 1.85 mm (f) to 1.85 mm (f) adapter
- 85058-60115 1.85 mm (m) to 1.85 mm (f) adapter

85058E economy: DC to 67 GHz. Includes:

- 85058-60101 1.85 mm (m) short 5.4 mm
- 85058-60105 1.85 mm (f) short 5.4 mm
- 85058-60109 1.85 mm male open
- 85058-60110 1.85 mm female open
- 85058-60123 1.85 mm male load
- 85058-60124 1.85 mm female load
- 85058-60113 1.85 mm (m) to 1.85 mm (m) adapter
- 85058-60114 1.85 mm (f) to 1.85 mm (f) adapter
- 85058-60115 1.85 mm (m) to 1.85 mm (f) adapter

### Electronic calibration kits

N4694D Microwave ECal: DC or 10 MHz to 67 GHz, 2-ports. Includes:

- Option F0F: Both connectors are 1.85 mm female on module
- Option M0F: 1 female and 1 male 1.85 mm connector on module
- Option M0M: Both connectors are 1.85 mm male on module
- Option 0DC: DC to 67 GHz
- Option 100: 10 MHz to 67 GHz
- Option 00A adds:
  - 85058-60113 1.85 mm (m) to 1.85 mm (m) adapter

- 85058-60114 1.85 mm (f) to 1.85 mm (f) adapter

## Cables

- N4697J<sup>1</sup> Single, flexible: 1.85 mm (f) to 1.85 mm (f), 96.5 cm, 38 inches
- N4697K<sup>1</sup> Set, flexible:
  - One 1.85 mm (f) to 1.85 mm (f) cable, 62.2 cm, 24.5 inches, p/n N4697-60100
  - One 1.85 mm (f) to 1.85 mm (m) cable, 62.2 cm, 24.5 inches, p/n N4697-60200
- N4421B-K67 Single, flexible: 1.85 mm (f) to 1.85 mm (m), 91.4 cm, 36 inches

## Adapter set

- 85130H<sup>1</sup> 1.85 mm to 1.85 mm
  1. Special rugged female connector specifically for connecting to the network analyzer test port, but does not mate with a standard male connector. The N4697J/K replace the N4697E/F, which will be discontinued on June 1, 2020.

## For devices with 2.4 mm connectors

### Mechanical calibration kit

85056A standard: DC to 50 GHz. Includes:

- 00901-60003 2.4 mm (m) fixed broadband load
- 00902-60004 2.4 mm (f) fixed broadband load
- 00915-60003 2.4 mm (m) sliding load
- 00915-60004 2.4 mm (f) sliding load
- 85056-60005 2.4 mm (m) to 2.4 mm (m) adapter
- 85056-60006 2.4 mm (f) to 2.4 mm (f) adapter
- 85056-60007 2.4 mm (m) to 2.4 mm (f) adapter
- 85056-60020 2.4 mm (m) short
- 85056-60021 2.4 mm (f) short
- 85056-60022 2.4 mm (m) open
- 85056-60023 2.4 mm (f) open

85056D economy: DC to 50 GHz. Includes:

- 00901-60003 2.4 mm (m) fixed broadband load
- 00902-60004 2.4 mm (f) fixed broadband load
- 85056-60005 2.4 mm (m) to 2.4 mm (m) adapter
- 85056-60006 2.4 mm (f) to 2.4 mm (f) adapter
- 85056-60007 2.4 mm (m) to 2.4 mm (f) adapter
- 85056-60020 2.4 mm (m) short
- 85056-60021 2.4 mm (f) short
- 85056-60022 2.4 mm (m) open
- 85056-60023 2.4 mm (f) open

## Electronic calibration kits

N4693D<sup>1</sup> Microwave ECal: DC or 10 MHz to 50 GHz, 2-ports. Includes:

- Option F0F: Both connectors are 2.4 mm female on module
- Option M0F: 1 female and 1 male 2.4 mm connector on module
- Option M0M: Both connectors are 2.4 mm male on module
- Option 0DC: DC to 50 GHz
- Option 100: 10 MHz to 50 GHz
- Option 00A adds:
  - 85056-60005 2.4 mm (m) to 2.4 mm (m) adapter
  - 85058-60006 2.4 mm (f) to 2.4 mm (f) adapter

## Cables

Note: Keysight offers the following 2.4 mm test port cables. Adapters will be necessary when using these cables for 2.92 mm measurements.

- 85133C<sup>1</sup> single, semi-rigid: 2.4 mm (f) to PSC-2.4 mm (f), 81 cm, 32 inches
- 85133D<sup>1</sup> set, semi-rigid:
  - One 2.4 mm (f) to 2.4 mm (m), 53 cm, 21 inches, p/n 85133-60001
  - One 2.4 mm (f) to 2.4 mm (f), 53 cm, 21 inches, p/n 85133-60002
- 85133E<sup>1</sup> single, flexible: 2.4 mm (f) to PSC-2.4 mm (f), 97 cm, 38 inches
- 85133F<sup>1</sup> set, flexible:
  - One 2.4 mm (f) to 2.4 mm (f), 63 cm, 25 inches, p/n 85133-60016
  - One 2.4 mm (f) to 2.4 mm (m), 63 cm, 25 inches, p/n 85133-60017
- 85133H<sup>1</sup> Single, flexible: 2.4 mm (f) to 2.4 mm (m), 63 cm, 25 inches
- N4421AK20 Single, flexible: 2.4 mm (f) to 2.4 mm (m), 91.4 cm, 36 inches

## Adapter set

- 85130E 2.4 mm<sup>1</sup> to 7 mm
- 85130F 2.4 mm<sup>1</sup> to 3.5 mm
- 85130G 2.4 mm<sup>1</sup> to 2.4 mm

1. Special rugged female connector specifically for connecting to the network analyzer test port, but does not mate with a standard male connector.

## For devices with K connectors (2.92 mm)

### Mechanical calibration kits

#### 85056KE01 DC to 40 GHz

For use with user supplied 2.92 mm test port cables. 2.92 mm (K connector) calibration kit with fixed and sliding loads. The Keysight 85056KE01 calibration kit is an ordering convenience to allow the pass-through ordering from Keysight for the Maury 8770E47 calibration kit.

#### 85056KE02 DC to 40 GHz

For use with user supplied 2.92 mm test ports cables. 2.92 mm (K connector) calibration kit with fixed loads only. The Keysight 85056KE02 calibration kit is an ordering convenience to allow the pass-through ordering from Keysight for the Maury 8770F47 calibration kit.

The 85056KE01 and 85056KE02 contains one NMD 2.4 mm<sup>1</sup> (f) to 2.92 mm (f) and one NMD 2.4 mm<sup>1</sup> (f) to 2.92 mm (m) test port adapter to adapt the 2.4 mm test ports of the VNA to 2.92 mm. It also supplies 2.92 mm to 2.92 mm in-series adapters (3 adapters) and a VNA Cal Coefficients on a USB stick. Users must supply their own 2.92 mm or K-connector test port cables. Also included is a 2.92 mm torque wrench.

Maury Microwave Terms and Conditions for Warranty and Return apply. Maury Microwave Corp. calibration kits are to be returned directly to Maury Microwave for service, repair, or calibration issues and not to Keysight Technologies. For additional information go to [www.maurymicrowave.com](http://www.maurymicrowave.com).

Keysight Technologies does not guarantee the performance of the Maury calibration kits or the system performance when connected to Keysight Vector network analyzers.

1. Special rugged female connector specifically for connecting to the network analyzer test port, but does not mate with standard 2.4 mm male connector

### Electronic calibration kits

N4692D Microwave ECal: DC or 10 MHz to 40 GHz, 2-ports. Includes:

- Option F0F: Both connectors are 2.92 mm female on module
- Option M0F: 1 female and 1 male 2.92 mm connector on module
- Option M0M: Both connectors are 2.92 mm male on module
- Option 0DC: DC to 40 GHz
- Option 100: 10 MHz to 40 GHz
- Option 00A adds:
  - N4692-60021 2.92 mm (m) to 2.92 mm (m) adapter
  - N4692-60022 2.92 mm (f) to 2.92 mm (f) adapter

## Cables

Note: Keysight offers the following 2.4 mm test port cables. Adapters will be necessary when using these cables for 2.92 mm measurements.

85133C<sup>1</sup> single, semi-rigid: 2.4 mm (f) to PSC-2.4 mm (f), 81 cm, 32 inches

85133D<sup>1</sup> set, semi-rigid: One 2.4 mm (f) to 2.4 mm (m), 53 cm, 21 inches, p/n 85133-60001

One 2.4 mm (f) to 2.4 mm (f), 53 cm, 21 inches, p/n 85133-60002

85133E<sup>1</sup> single, flexible: 2.4 mm (f) to PSC-2.4 mm (f), 97 cm, 38 inches

85133F<sup>1</sup> set, flexible: One 2.4 mm (f) to 2.4 mm (f), 63 cm, 25 inches, p/n 85133-60016

One 2.4 mm (f) to 2.4 mm (m), 63 cm, 25 inches, p/n 85133-60017

85133H<sup>1</sup> Single, flexible: 2.4 mm (f) to 2.4 mm (m), 63 cm, 25 inches

N4421AK20 Single, flexible: 2.4 mm (f) to 2.4 mm (m), 91.4 cm, 36 inches

## Adapters

- 11904A 2.4 mm (m) to 2.92 mm (m)
- 11904B 2.4 mm (f) to 2.92 mm (f)
- 11904C 2.4 mm (m) to 2.92 mm (f)
- 11904D 2.4 mm (f) to 2.92 mm (m)
- 11904S 2.4 mm to 2.92 mm: Adapter set, contains 4 matched adapters

1. Special rugged female connector specifically for connecting to the network analyzer test port, but does not mate with a standard male connector.

## For devices with 3.5 mm or SMA connectors

### Mechanical calibration kits

85033E economy: DC to 9 GHz. Includes:

- 85033-60016 3.5 mm (m) load
- 85033-60017 3.5 mm (f) load
- 85033-60018 3.5 mm (m) open
- 85033-60019 3.5 mm (f) open
- 85033-60020 3.5 mm (m) short
- 85033-60021 3.5 mm (f) short
- 8710-1761 torque wrench

Option 85033E-100 adds:

- 85027-60005 3.5 mm (f) to 3.5 mm (f) adapter

Option 85033E-200 adds:

- 85027-60007 3.5 mm (m) to 3.5 mm (m) adapter

Option 85033E-300 adds:

- 85027-60006 3.5 mm (m) to 3.5 mm (f) adapter

Option 85033E-400 adds:

- 1250-1744 3.5 mm (f) to 50  $\Omega$  Type-N (m) adapter
- 1250-1743 3.5 mm (m) to 50  $\Omega$  Type-N (m) adapter
- 1250-1745 3.5 mm (f) to 50  $\Omega$  Type-N (f) adapter
- 1250-1750 3.5 mm (m) to 50  $\Omega$  Type-N (f) adapter

Option 85033E-500 adds:

- 1250-1746 3.5 mm (m) to 7 mm adapter (two included)
- 1250-1747 3.5 mm (f) to 7 mm adapter (two included)

85052B standard: DC to 26.5 GHz. Includes:

- 00902-60003 3.5 mm (m) fixed load
- 00902-60004 3.5 mm (f) fixed load
- 00911-60019 3.5 mm (m) sliding load
- 00911-60020 3.5 mm (f) sliding load
- 85052-60006 3.5 mm (m) short
- 85052-60007 3.5 mm (f) short
- 85052-60008 3.5 mm (m) open
- 85052-60009 3.5 mm (f) open
- 85052-60012 3.5 mm (f) to 3.5 mm (f) adapter
- 85052-60013 3.5 mm (f) to 3.5 mm (m) adapter
- 85052-60014 3.5 mm (m) to 3.5 mm (m) adapter

85052C precision TRL: DC to 26.5 GHz. Includes:

- 00902-60003 3.5 mm (m) fixed load
- 00902-60004 3.5 mm (f) fixed load
- 85052-60006 3.5 mm (m) short
- 85052-60007 3.5 mm (f) short
- 85052-60008 3.5 mm (m) open
- 85052-60009 3.5 mm (f) open
- 85052-60032 3.5 mm (f) to 3.5 mm (f) adapter
- 85052-60033 3.5 mm (m) to 3.5 mm (m) adapter
- 85052-60034 3.5 mm (f) to 3.5 mm (m) adapter
- 85052-60035 3.5 mm short TRL line
- 85052-60036 3.5 mm long TRL line



85052D economy: DC to 26.5 GHz. Includes:

- 00902-60003 3.5 mm (m) fixed load
- 00902-60004 3.5 mm (f) fixed load
- 85052-60006 3.5 mm (m) short
- 85052-60007 3.5 mm (f) short
- 85052-60008 3.5 mm (m) open
- 85052-60009 3.5 mm (f) open
- 85052-60012 3.5 mm (f) to 3.5 mm (f) adapter
- 85052-60013 3.5 mm (f) to 3.5 mm (m) adapter
- 85052-60014 3.5 mm (m) to 3.5 mm (m) adapter

85052DH02 economy with data-based calibration standards: DC to 26.5 GHz. Includes:

- 5972-3342 USB flash drive
- 00902-60003 3.5 mm (m) fixed load
- 00902-60004 3.5 mm (f) fixed load
- 85052-60006 3.5 mm (m) short
- 85052-60007 3.5 mm (f) short
- 85052-60008 3.5 mm (m) open
- 85052-60009 3.5 mm (f) open
- 85052-60012 3.5 mm (f) to 3.5 mm (f) adapter
- 85052-60013 3.5 mm (f) to 3.5 mm (m) adapter
- 85052-60014 3.5 mm (m) to 3.5 mm (m) adapter

### Electronic calibration (ECal) modules

85093C RF ECal: 300 kHz to 9 GHz, 2-ports.

- Option 00F: Both 3.5 mm connectors are female
- Option 00M: Both 3.5 mm connectors are male
- Option M0F: One female and one male connector, both 3.5 mm
- Option 150: Replaces standard storage container with a wooden box
- 85093-00A: Adds 3.5 mm adapters
  - 85052-60012 3.5 mm (f) to 3.5 mm (f) adapter
  - 85052-60014 3.5 mm (m) to 3.5 mm (m) adapter

85093C mixed-connector options

Port A Option			Port B Option		
Connector type	Female	Male	Connector type	Female	Male
3.5 mm	101	102	Type-N 50 Ω	203	204
			7-16	205	206

N4431D Microwave ECal: DC to 13.5 GHz, 4 ports.

Frequency option (mandatory)

- Option 0DC: DC to 13.5 GHz

Connector options

- Option 010: 3.5 mm female connector on four ports on module
- Option 020: Type-N female connector on four ports on module

Connector type	Port A Option	Port B Option	Port C Option	Port D Option
Four 3.5 mm (f)	010			
Four Type-N 50 Ω (f)	020			
3.5 mm (f)	101	201	301	401
3.5 mm (m)	102	202	302	402
Type-N 50 Ω (f)	103	203	303	403
Type-N 50 Ω (m)	104	204	304	404
7-16 (f)	105	205	305	405
7-16 (m)	106	206	306	406
4.3-10 (f)	107	207	307	407
4.3-10 (m)	108	208	308	408

N4433D ECal: DC/300 kHz to 26.5 GHz, 4-ports.

Frequency options

- Option 0DC: DC to 26.5 GHz
- Option 003: 300 kHz to 26.5 GHz

Connector options:

- Option 010: 3.5 mm female connector on four ports on module

Connector type	Port A Option	Port B Option	Port C Option	Port D Option
Four 3.5 mm (f)	010			
3.5 mm (f)	101	201	301	401
3.5 mm (m)	102	202	302	402

N4691D Microwave ECal, DC or 300 kHz to 26.5 GHz, 2-ports. Includes:

- Option F0F: Both 3.5 mm connectors are female
- Option M0F: One female and one male connector, both 3.5 mm
- Option M0M: Both 3.5 mm connectors are male
- Option 0DC: DC to 26.5 GHz
- Option 003: 300 kHz to 26.5 GHz
- Option 00A adds:
  - 85052-60012 3.5 mm (f) to 3.5 mm (f) adapter
  - 85052-60014 3.5 mm (m) to 3.5 mm (m) adapter

N755XA Series Economy ECal, 2-ports:

- N7550A DC to 4 GHz, 2-ports
- N7551A DC to 6.5 GHz, 2-ports
- N7552A DC to 9 GHz, 2-ports
- N7553A DC to 14 GHz, 2-ports
- N7554A DC to 18 GHz, 2-ports
- N7555A DC to 26.5 GHz, 2-ports

N755xA Series includes:

- Option 3FF: Both 3.5 mm connectors are female
- Option 3MF: One female and one male connector, both 3.5 mm
- Option 3MM: Both 3.5 mm connectors are male
- Option 150: Plastic storage box
- N7550X-151: 3.5 mm or 2.92 mm torque wrench

## Cables

85131C<sup>1</sup> single, semi-rigid:

- 3.5 mm (f) to PSC-3.5 mm (f), 81 cm, 32 inches

85131D<sup>1</sup> set, semi-rigid:

- 85131-60009 One 3.5 mm (f) to 3.5 mm (m), 53 cm, 21 inches
- 85131-60010 One 3.5 mm (f) to PSC-3.5 mm (f), 53 cm, 21 inches

85131E<sup>1</sup> single, flexible:

- 3.5 mm (f) to PSC-3.5 mm (f), 96.5 cm, 38 inches

85131F<sup>1</sup> set, flexible:

- 85131-60012 One 3.5 mm (f) to 3.5 mm (m), 62.2 cm, 24.5 inches
- 85131-60013 One 3.5 mm (f) to PSC-3.5 mm (f), 62.2 cm, 24.5 inches

85131H<sup>1</sup> single, flexible:

- 3.5 mm (f) to 3.5 mm (m), 62.2 cm, 24.5 inches

85134E<sup>1</sup> single, flexible:

- PSC-3.5 mm (f) to 2.4 mm (f), 96 cm, 38 inches

85134F<sup>1</sup> set, flexible:

- 85134-60004 One 2.4 mm (f) to PSC-3.5 mm (f), 53 cm, 21 inches
- 85134-60003 One 2.4 mm (f) to PSC-3.5 mm (m), 53 cm, 21 inches

85134H<sup>1</sup> single, flexible:

- 2.4 mm (f) to PSC-3.5 mm (m), 53 cm, 21 inches

N4419AK20 single, flexible:

- 3.5 mm (m) to 3.5 mm (f), 91.4 cm, 36 inches

Z5623A-K20 single, flexible:

- 3.5 mm (m) to 3.5 mm (m), 91.4 cm, 36 inches

## Adapter sets

85130D 3.5 mm<sup>1</sup> to 3.5 mm

1. Special rugged female connector specifically for connecting to the network analyzer test port, but does not mate with a standard male connector.

## Connector repair kit

3.5 mm connector repair kit

- 85052-60049 Repair kit slotless
- 85052-60050 Contact – 3.5 package of 10
- 85052-60051 Repair kit slotless

## Test fixture

16198A bottom electrode SMD test fixture

- Option 010 10 GHz test fixture and adapter box
- Option 100 Standard set for 0201 (0.2 x 0.1 mm) surface mount devices (SMDs) <sup>1,2</sup>
- Option 200 Standard set for 0402 (0.4 x 0.2 mm) surface mount devices (SMDs) <sup>1,3</sup>
- Option 101 Contact board (Guide PCA 0201, 70 micrometer)
- Option 102 Contact board (Guide PCA 0201, 100 micrometer)
- Option 201 Contact board (Guide PCA 0402, 100 micrometer)
- Option 110 0201 short bar 5-piece set
- Option 210 0402 short bar 5-piece set
- Option 520 Weight 50 g
- Option 521 Weight 100 g
- Option 522 Weight 200 g
- Option 530 Carrying case
- Option 531 Torque driver

1. 16198A Option 100 and 200 are mutually exclusive.
2. Includes all accessories of Option 101/102/110/520/521/522.
3. Includes all accessories of Option 201/210/520/521/522.

## For devices with Type-N connectors

### Mechanical calibration kits

85032F standard, DC to 9 GHz Includes:

- 85032-60017 Type-N (m) fixed load
- 85032-60018 Type-N (f) fixed load
- 85032-60013 Type-N (m) open
- 85032-60014 Type-N (f) open
- 85032-60016 Type-N (m) short
- 85032-60015 Type-N (f) short

Option 85032F-100 adds:

- 85032-60021 Type-N (f) to Type-N (f) adapter

Option 85032F-200 adds:

- 85032-60019 Type-N (m) to Type-N (m) adapter

Option 85032F-300 adds:

- 85032-60020 Type-N (m) to Type-N (f) adapter

Option 85032F-500 adds:

- 85054-60001 Type-N (f) to 7 mm adapter (two included)
- 85054-60009 Type-N (m) to 7 mm adapter (two included)

85054B standard: DC to 18 GHz. Includes:

- 00909-60011 Type-N (m) fixed low-band load
- 00909-60012 Type-N (f) fixed low-band load
- 85054-60025 Type-N (m) short
- 85054-60026 Type-N (f) short
- 85054-60027 Type-N (m) open
- 85054-60028 Type-N (f) open
- 85054-60031 Type-N (f) to 7mm adapter
- 85054-60032 Type-N (m) to 7mm adapter
- 85054-60037 Type-N (f) to Type-N (f) adapter
- 85054-60038 Type-N (m) to Type-N (m) adapter
- 85054-80010 Type-N (f) sliding load
- 85054-80009 Type-N (m) sliding load
- 85054-60050 Type-N (f) connector gage
- 85054-60052 Type-N (f) gage master
- 85054-60051 Type-N (m) connector gage
- 85054-60053 Type-N (m) gage master

85054D economy: DC to 18 GHz. Includes:

- 85054-60025 Type-N (m) short
- 85054-60026 Type-N (f) short
- 85054-60027 Type-N (m) open
- 85054-60028 Type-N (f) open
- 85054-60031 Type-N (f) to 7mm adapter
- 85054-60032 Type-N (m) to 7mm adapter
- 85054-60037 Type-N (f) to Type-N (f) adapter
- 85054-60038 Type-N (m) to Type-N (m) adapter
- 85054-60046 Type-N (m) fixed load
- 85054-60047 Type-N (f) fixed load

## Electronic calibration (ECal) modules

85092C RF ECal: 300 kHz to 9 GHz, 2 ports. Includes:

- Option 00F: both Type-N connectors are female
- Option 00M: both Type-N connectors are male
- Option M0F: one female and one male connector, both Type-N
- Option 00A adds:
  - 85054-60037 Type-N (f) to Type-N (f) adapter
  - 85054-60038 Type-N (m) to Type-N (m) adapter

N4431D Microwave ECal: DC to 13.5 GHz, 4 ports.

Frequency option (mandatory)

- Option 0DC: DC to 13.5 GHz

Connector options

- Option 010: 3.5 mm female connector on four ports on module
- Option 020: Type-N female connector on four ports on module

Connector type	Port A Option	Port B Option	Port C Option	Port D Option
Four 3.5 mm (f)	010			
Four Type-N 50 Ω (f)	020			
3.5 mm (f)	101	201	301	401
3.5 mm (m)	102	202	302	402
Type-N 50 Ω (f)	103	203	303	403
Type-N 50 Ω (m)	104	204	304	404
7-16 (f)	105	205	305	405
7-16 (m)	106	206	306	406
4.3-10 (f)	107	207	307	407
4.3-10 (m)	108	208	308	408

N4432D Microwave ECal: DC/300 kHz to 18 GHz, 4-ports.

Frequency option (mandatory)

- Option 0DC: DC to 18 GHz
- Option 003 300 kHz to 18 GHz

Connector options

- Option 020: Type-N female connector on four ports on module

Connector type	Port A Option	Port B Option	Port C Option	Port D Option
Four Type-N 50 Ω (f)	020			
3.5 mm (f)	101	201	301	401
3.5 mm (m)	102	202	302	402
Type-N 50 Ω (f)	103	203	303	403
Type-N 50 Ω (m)	104	204	304	404

N4690D Microwave ECal, DC or 300 kHz to 18 GHz, 2-ports. Includes:

- Option F0F: Both Type-N connectors are female
- Option M0F: One female and one male connector, both Type-N connectors
- Option M0M: Both Type-N connectors are male
- Option 0DC: DC to 18 GHz
- Option 003: 300 kHz to 18 GHz
- Option 00A adds:
  - 85054-60037 Type-N (f) to Type-N (f) adapter
  - 85054-60038 Type-N (m) to Type-N (m) adapter

N755XA Series Economy ECal, 2-ports:

- N7550A DC to 4 GHz, 2-ports
- N7551A DC to 6.5 GHz, 2-ports
- N7552A DC to 9 GHz, 2-ports
- N7553A DC to 14 GHz, 2-ports
- N7554A DC to 18 GHz, 2-ports

N755xA Series includes:

- Option NFF: Both Type-N connectors are female
- Option NMF: One female and one male connector, both Type-N
- Option NMM: Both Type-N connectors are male
- Option 150: Plastic storage box
- N7550X-152: Type-N torque wrench

## Cables

N6314A 50  $\Omega$  Type-N RF cable, DC to 12.4 GHz Includes:

- 8120-8862 one 610 mm (24 in) cable with male connectors

N6315A 50  $\Omega$  Type-N RF cable, DC to 12.4 GHz Includes:

- 8121-0027 one 610 mm (24 in) cable with both female and male connectors



## Adapter sets

11853A 50  $\Omega$  Type-N accessory kit. Includes:

- 1250-1472 Type-N (f) to Type-N (f) adapter (two included)
- 1250-1475 Type-N (m) to Type-N (m) adapter (two included)
- 11511A Type-N (f) short
- 11512A Type-N (m) short

11878A Type-N to 3.5 mm adapter kit. Includes:

- 1250-1744 3.5 mm (f) to 50  $\Omega$  Type-N (m) adapter
- 1250-1743 3.5 mm (m) to 50  $\Omega$  Type-N (m) adapter
- 1250-1745 3.5 mm (f) to 50  $\Omega$  Type-N (f) adapter
- 1250-1750 3.5 mm (m) to 50  $\Omega$  Type-N (f) adapter

11524A 7 mm to Type-N (f) adapter

11525A 7 mm to Type-N (m) adapter

85130C 3.5 mm to Type-N Includes:

- 85054-60029 3.5 mm to Type-N (f)
- 85054-60030 3.5 mm to Type-N (m)

## For devices with 7 mm connectors

### Mechanical calibration kits

85050B standard: DC to 18 GHz. Includes:

- 00909-60008 7 mm coax termination
- 85050-60006 7 mm fixed broadband load
- 85050-80007 7 mm short
- 85050-80010 7 mm open
- 85050-80011 7 mm sliding load

85050C precision TRL: DC to 18 GHz. Includes:

- 00909-60008 7 mm coax termination
- 85050-60003 7 mm to 7 mm airline
- 85050-60005 7 mm to 7 mm TRL adapter
- 85050-60006 7 mm fixed broadband load
- 85050-80008 7 mm short
- 85050-80009 7 mm short with collect
- 85050-80010 7 mm open

85050D economy: DC to 18 GHz. Includes:

- 85050-60006 7 mm fixed broadband load
- 85050-80007 7 mm short
- 85050-80010 7 mm open

### Electronic calibration (ECal) modules

N4696D Microwave ECal: DC or 300 kHz to 18 GHz, 2-ports, 7 mm connectors. Includes:

- Option 0DC: DC to 18 GHz
- Option 003: 300 kHz to 18 GHz

## For devices with waveguide

### Mechanical calibration kits

X-Band

X11644A standard, WR-90: 8.2 to 12.4 GHz. Includes:

- 00896-60008 X-band standard section
- 00910-60003 X-band termination
- 11644-20018 X-band short
- 11644-20021 X-band shim

X281C adapter (included in calibration kit): WR-90 to 7 mm

## P Band

P11644A standard, WR-62: 12.4 to 18 GHz. Includes:

- 00896-60007 P-band standard section
- 00910-60002 P-band termination
- 11644-20017 P-band short
- 11644-20020 P-band shim
- P281C adapter (included in calibration kit): WR-62 to 7 mm

## K Band

K11644A standard, WR-42: 18 to 26.5 GHz. Includes:

- 00896-60006 K-band standard section
- 00910-60001 K-band termination
- 11644-20016 K-band short
- 11644-20019 K-band shim

K281C adapter (included in calibration kit): WR-42 to 3.5 mm (f) Option 012 WR-42 to 3.5 mm (m)

## R Band

R11644A standard, WR-28: 26.5 to 40 GHz. Includes:

- 00914-20028 R-band termination
- 11644-20005 R-band short
- 11644-20003 R-band shim
- 11644-60001 R-band 10 cm straight waveguide
- 11644-60016 R-band 5 cm straight waveguide

## Q Band

Q11644A standard, WR-22: 33 to 50 GHz. Includes:

- 11644-60005 Q-band termination
- 11644-20004 Q-band short
- 11644-20001 Q-band shim
- 11644-60002 Q-band 10 cm straight waveguide
- 11644-60017 Q-band 5 cm straight waveguide

## U Band

U11644A standard, WR-19: 40 to 60 GHz. Includes:

- 11644-60006 U-band termination
- 11644-20004 U-band short
- 11644-20002 U-band shim
- 11644-60003 U-band 10 cm straight waveguide
- 11644-60018 U-band 5 cm straight waveguide

## Verification kits

All Keysight verification kits include:

- Precision Z0 airline or match thru
- Mismatched airline or mismatch thru
- Fixed attenuators
- Traceable measured data and uncertainties

### 85051B 45 MHz to 18 GHz 7 mm kit

Includes attenuators, airline and mismatch airline with data on a USB drive for use in confirming calibrated system performance, traceable to national standards. Test procedure is provided in the service manual.

### 85053B 300 kHz to 26.5 GHz 3.5 mm kit

Includes attenuators, airline and mismatch airline with data on a USB drive for use in confirming calibrated system performance, traceable to national standards. Test procedure is provided in the service manual.

### 85055A 300 kHz to 18 GHz Type-N kit

Includes attenuators, airline and mismatch airline with data on a USB drive for use in confirming calibrated system performance, traceable to national standards. Test procedure is provided in the service manual.

### 85057B 45 MHz to 50 GHz 2.4 mm kit

Includes attenuators, airline and mismatch airline with data on a USB drive for use in confirming calibrated system performance, traceable to national standards. Test procedure is provided in the service manual.

### 85058V 45 MHz to 67 GHz 1.85 mm kit

Includes attenuators, match thru and mismatch thru with data on a USB drive for use in confirming calibrated system performance, traceable to national standards. Test procedure is provided in the service manual.

## Accessories

### CalPod calibration refresh modules (8553xB/4xB)

CalPod calibration refresh modules allow in-situ calibration refreshes to be performed at the push of a button without removing the DUT or re-connecting calibration standards. CalPods are designed for any measurement situation where it is desirable to ensure that a valid calibration is present before recording measurement data. For example, they are useful for removing environmental effects such as cable movement and thermal-based changes of cables, connectors, and adapters, as well as connector and switch-matrix repeatability errors. The modules are especially useful in temperature, or thermal-vacuum chamber testing. CalPod modules are equipped with 2.92 mm connectors.

- 85530B 20 GHz ambient-temperature CalPod
- 85531B 20 GHz temperature-compensated CalPod
- 85532B 20 GHz thermal-vacuum compatible CalPod
- 85540B 40 GHz ambient-temperature CalPod
- 85541B 40 GHz temperature-compensated CalPod
- 85542B 40 GHz thermal-vacuum compatible CalPod
- 85523B CalPod controller (provides control for up to 4 CalPods)
- 85556A CalPod drive-cable splitter (allows control for up to 12 CalPods)
- 85554A CalPod drive cable extension (10-meter cascable extension cable)

### Spare drive

E5080BU-180 Solid State Drive (SSD) Spare Kit

## Upgrade Your System

Upgrade kits are available to add options after initial purchase. To upgrade the E5080B ENA, order the corresponding item number. To add application software, order the appropriate standalone model numbers (S96xxxB).

A complete list of E5080B upgrade kits is available on our Web site:

[www.keysight.com/find/e5080bupgrades](http://www.keysight.com/find/e5080bupgrades)

## E5080B and E5071C Comparison

Switching from the E5071C to the E5080B simplifies complex measurements with integrated functionality and applications. You also get reliability and repeatability from best-in-class performance in dynamic range, trace noise, speed, and frequency range.

Features	E5071C	E5080B
Frequency range	9 kHz to 4.5/6.5/8.5 GHz (Option 2x0, 4x0, without bias tees) 100 kHz to 4.5/6.5/8.5 GHz (Option 2x5, 4x5, with bias tees) 300 kHz to 14/20 GHz (with bias tees)	9 kHz to 4.5/6.5/9/14/18/20 GHz (option 2x0, 4x0, 4x2, without bias tees) 100 kHz to 26.5/32/44/53 GHz (option 2x0, 4x0, 4x2, without bias tees)
Test port connectors	Type-N (female) (4.5/6.5/8.5 GHz) 3.5 mm (male) (14/20 GHz)	Type-N (female) (4.5/6.5/8.5/14/18 GHz) 3.5 mm (male) (14/18/20/26.5 GHz) 2.4 mm (male) (32/44 GHz) 1.85 mm (male) (53 GHz)
High stability timebase	Optional (Option 1E5)	Optional (Option 1E5)
GPIB interface	Standard	Optional (Option 172)
Analog DC output (DC sources)	None	Optional (Option 175)
Internal bias tees	Standard (Option 2x5, 4x5. Up to 20 GHz)	Optional (Option 120, 140. Up to 20 GHz)
Data storage	Built-in HDD (standard. Option 019) Removable HDD (Option 017)	Removable SSD (standard)
Pulse modulator hardware	None	Optional (Option 021/022)
Spectrum analysis hardware	None	Optional (Option 09x)
Internal second source	None	Optional (Option 4x2)
Frequency offset mode / scaler calibrated mixer measurements	Option 008	S96082B
Time domain analysis	Option 010	S96010B
Enhanced time domain analysis with TDR	Option TDR	S96011B

## Literature Information

Keysight E5080B ENA Series Vector Network Analyzer – Data Sheet, [5992-3843EN](#)

Keysight E5071C to E5080B Code Migration Guide, [5992-3873EN](#)

Keysight Vector Network Analyzer – Selection Guide, [5989-7603EN](#)

Electric Calibration (ECal) Modules – Technical Overview, [5963-3743E](#)

Drive Down the Cost of Test Using the ENA – Application Note, [5992-0195EN](#)

## Web Resources

[www.keysight.com/find/ena](http://www.keysight.com/find/ena)

[www.keysight.com/find/na](http://www.keysight.com/find/na)

[www.keysight.com/find/vnasoftware](http://www.keysight.com/find/vnasoftware)

[www.keysight.com/find/ecal](http://www.keysight.com/find/ecal)

Learn more at: [www.keysight.com](http://www.keysight.com)

For more information on Keysight Technologies' products, applications, or services, please contact your local Keysight office. The complete list is available at: [www.keysight.com/find/contactus](http://www.keysight.com/find/contactus)

