

# DLRO-H200

## Micro-ohmmeter



- **Up to 220 A**
- **Battery supplied**
- **Lightweight – 1 kg**
- **Safe test – DualGround™**
- **Auto range: 1 μΩ to 1000 mΩ**
- **Bluetooth® PC communication**
- **Complies with IEEE and IEC standards**

### DESCRIPTION

The DLRO-H200 is designed to measure the resistance of circuit breaker contacts, bus-bar joints and other high-current links. This product is designed with safety, ease of use and versatility in mind.

The micro-ohmmeter can be used anywhere to measure a low resistance value with high accuracy.

DLRO-H200 uses an ultra capacitor to generate the high output current. The ultra capacitor is able to store a huge amount of energy compared to conventional capacitors and can deliver very high current during the discharge thanks to its very low internal resistance.

While testing, the capacitor is discharged through the test object and the voltage drop across- and the current flow through the test object are continuously and synchronously sampled. The resistances calculated from the individual samples are then averaged to obtain the final value.

With DLRO-H200 it is possible to make measurements according to the DualGround™ method. This means that the test object will be grounded on both sides throughout the test giving a safer, faster and easier workflow.

The ruggedness and lightweight makes DLRO-H200 a handheld instrument very suitable for field work, such as in substations. The unit comes with a strong rubber holster accessory which makes it extra durable. DLRO-H200 is dimensioned to make a full day's work of testing without recharge. It can store 190 test values and transfer test data to a PC via Bluetooth.

### APPLICATIONS

DLRO-H200 test system is designed to serve a number of applications. The most common are contact resistance measurements of low-, medium- and high-voltage breakers and also at bus-bar joints, and other high current links.

If the contact resistance is too high this will lead to power loss and temperature rise, which often leads to serious trouble. To avoid such problems, it is necessary to check the resistance at regular intervals.

The following table demonstrates how important low resistance is at high currents:

Current	Contact resistance	Power loss
10 kA	1 mΩ	100 kW
10 kA	0.1 mΩ	10 kW
1 kA	1 mΩ	1 kW
1 kA	0.1 mΩ	100 W

At 10 kA a contact with the resistance 0.1 mΩ gives a power loss of 10 kW. This power loss in one single point will definitely confer a temperature rise, which may result in overheating and possibly premature failure.

**FEATURES AND BENEFITS**

1. Current output terminal (-)
2. Current output terminal (+)
3. Display  
The display offers a combination of analogue arc and a dual digital readout:
  - Analogue arc:  
Indicates level of the capacitor charge.
  - Dual digital display:  
Large main digital readout for good visibility of all main measurement results  
Second digital display for additional data.
4. Ground (earth) terminal
5. Keys for navigation and to make settings in the display
6. TEST-button
7. Stand-by/Wake up (Press shortly to toggle)  
Clear log (Press and hold for 5 seconds)

**8. Function selector**

<b>OFF</b>		
<b>I nom</b>	<b>0.1 s</b>	Test positions Measurement time with minimum current guarantee
	<b>0.6 s</b>	
	<b>3 s</b>	
<b>I max</b>	<b>0.1 s</b>	Test positions Measurement time with max. charge
	<b>0.6 s</b>	
	<b>3 s</b>	
<b>Setup</b>		Bluetooth "pair units"
		<ul style="list-style-type: none"> <li>▪ Set date and time</li> <li>▪ Set volume for the internal buzzer</li> <li>▪ Discharge the DLRO-H200 internal capacitor</li> </ul>
	<b>I nom</b>	Minimum current guarantee setting
	<b>LOG</b>	Data log settings
	<b>P/F</b>	Pass/Fail settings
	<b>PC COM</b>	PC communication (dump data to PC)
<b>Presets</b>	<b>1</b>	Test positions
	<b>2</b>	Stored settings
	<b>3</b>	(Set from PC SW)

9. Connector for the voltage (-) sense lead
10. Connector for the voltage sense (+) lead and the trig function
11. Connector for the battery charger
12. Battery charger indicator

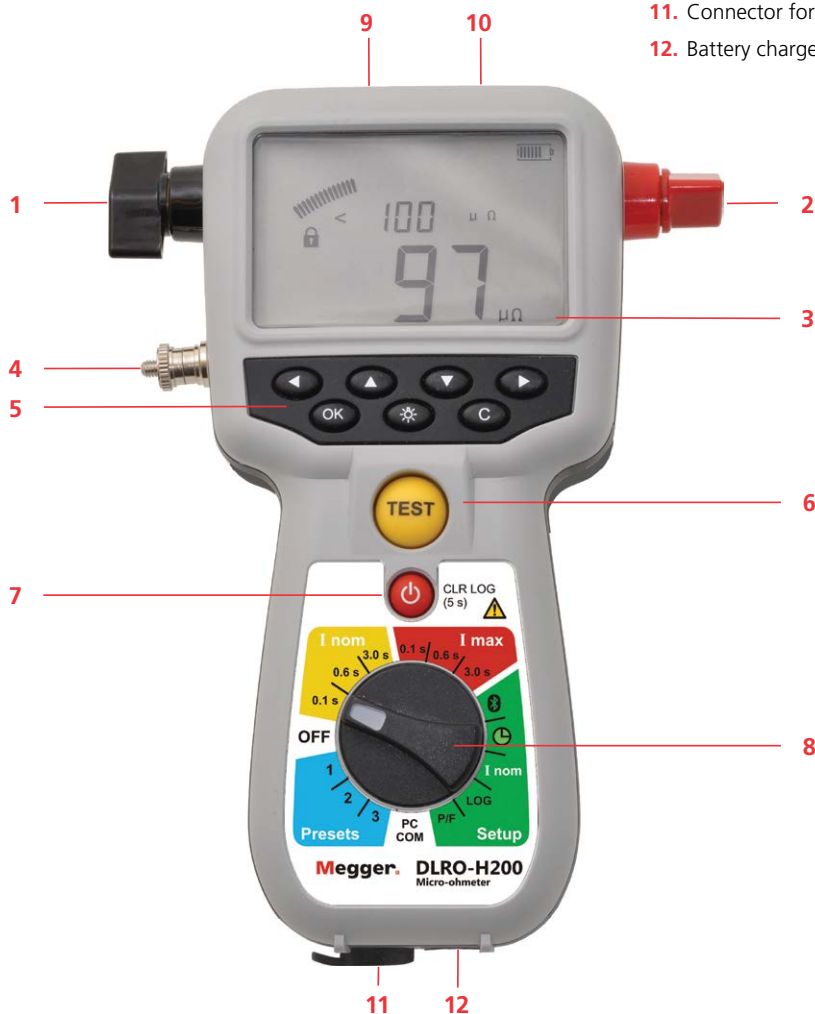

**APPLICATION EXAMPLES**

**Circuit Breaker testing**

- Test of circuit breaker contacts
- Test of the connections to the breaker

**Testing of Bus-bar**

- Test of Bus-bar joints
- Test of connections

**Everywhere you need to test a low resistance/  
high current connection**

- Switches
- Disconnecting devices
- Safety ground connections
- Welding points
- Fuses
- Cables



Hold probes / attach Kelvin clamps to CB and press trig / TEST button. A signal indicates whether test was pass or fail and result is logged in unit for later dump to PC.

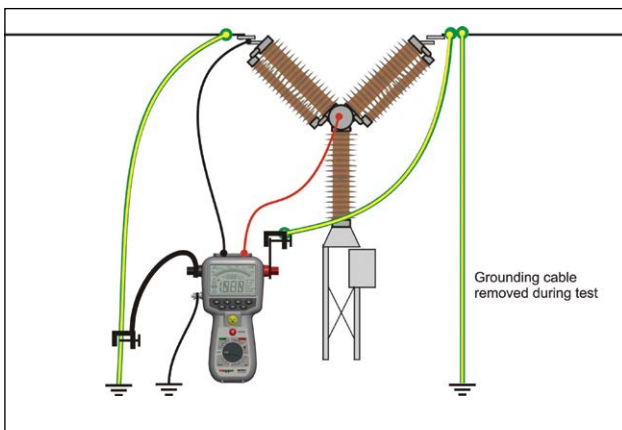

Traditional measurement from ground. Injection is done through existing grounding cable (earthing). Use any of the optional cable kits, GA-00380/82/84, with 5, 10 or 15 m cables.

**BOTH SIDES GROUNDED**

Many utilities require safety grounds to remain in place during station outages, therefore, the DLRO-H200 was designed with this field safety constraint in mind. DualGround means that the test object will be grounded on both sides throughout the test giving a safer, faster and easier workflow. Minimum time shall be spent in the substation and focus shall be on the test rather than the equipment.

Conventional vs. DualGround	
Site preparation (isolate work area, apply safety ground, issue permit to work)	Site preparation (isolate work area, apply safety ground, issue permit to work)
Hook up test equipment. Issue sanction for test	Hook up test equipment. Issue sanction for test
Authorised person removes the ground	Risky step left out
Perform testing	Safe testing with both sides grounded
Authorised person applies ground	Risky step left out
Cancel sanction for test. Disconnect test equipment	Cancel sanction for test. Disconnect test equipment
Site closing (cancel permit to work, disconnect ground)	Site closing (cancel permit to work, disconnect ground)



Equipment and methods that supports DualGround™ testing are associated with the DualGround symbol. This symbol certifies the use of groundbreaking technology and methods that enables a safe, fast and easy workflow with both sides grounded throughout the test.

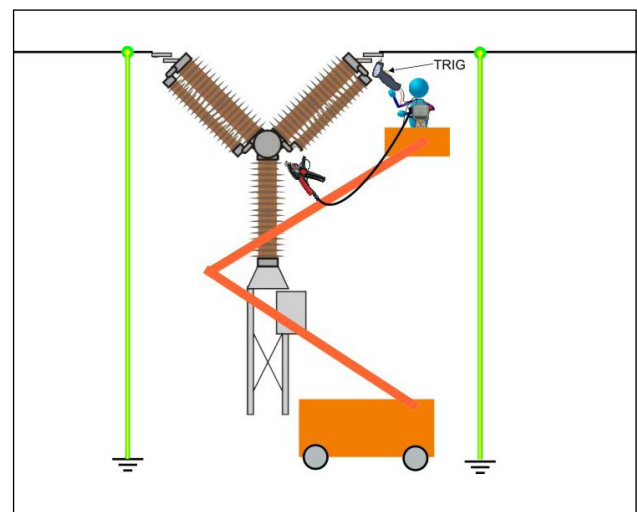

Measurement on CB with both sides grounded, DualGround. Here is a combination of one clamp and one probe used.

4 WIRE KELVIN TEST

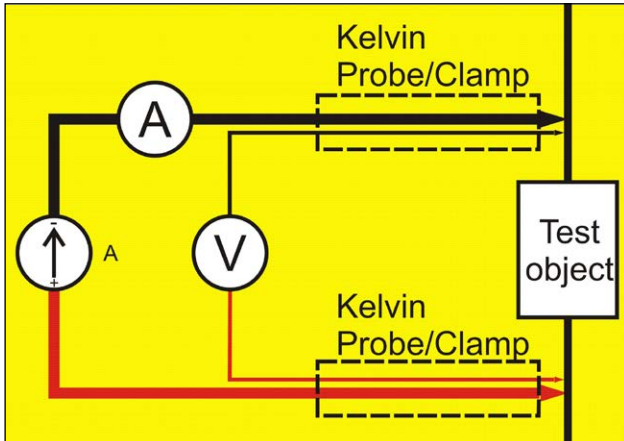

The Kelvin probes (incl. in BD-59090) are used for a 4 wire Kelvin test. This is a way of measuring continuity resistances ensuring all contact and lead resistances are compensated for, which allows a much greater accuracy in measurements. Each Kelvin probe assembly has two probe tips. One tip is for the current generated and the other will measure the very small voltage present.

The Kelvin clamps (incl. in BD-59092) uses the same principle.

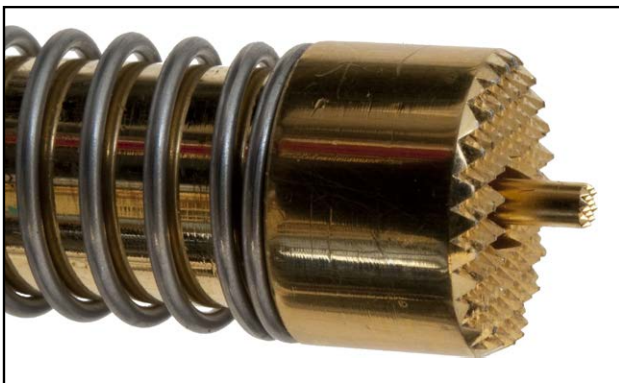

The "double" probe tip showing the springy center tip.



DLRO-H200 (BD-59192) with Transport case, Charger, Kelvin clamps, Rubber holster, Carrying strap, Belt clip, DLRO-H200 Win.

**SPECIFICATIONS**

Specifications are valid at fully charged batteries and an ambient temperature of +25°C, (77°F). Specifications are subject to change without notice.

**Environment**

*Application field* For use in high-voltage substations and industrial environments.

*Temperature*

*Operation* -20°C to +50°C (-4°F to +122°F) \*)  
*Storage* -40°C to +70°C (-40°F to +158°F)

*Relative humidity %RH* 5%-95%, non condensing

*Pollution degree* 2

*Shock* IEC 60068-2-27

*Vibration* IEC 60068-2-6

*Transport* ISTA 2A

\*) Battery operation temperature 0°C to +50° (32°F to +122°F)  
Battery charging temperature +10°C to +40° (50°F to +104°F)

**CE-marking**

*EMC* 2004/108/EC

*LVD* 2006/95/EC

**General**

*Battery power* Five AA (HR6) 2700 mAh NiMH cells

*Recharge time* < 12 h

*Typical recharge time at 25°C* 3 h

*Battery charger*

*Mains voltage* 100-250 V AC, 50 / 60 Hz

*Power consumption* 60 W

*Protection* Against wrong battery type, low/high temperature.

*Real time clock battery life* ≥10 years

*Audible feedback* Different buzzer sounds

*User presets* 3

*Field calibration* Yes

*Encapsulation* IP54

*Dimensions (excl. binding posts)* 217 x 104 x 72 mm  
8.5 x 4.1 x 2.8 in.

*Weight* 1.0 kg (2.2 lbs) instrument only  
5.0 kg (11 lbs) with accessories and carrying case

**Measurement section**

*Minimum current guarantee* Selectable 50 A / 100 A  
Valid at resistance ≤2mΩ

*Pass / Fail* Settable from 1 μΩ to 1999 mΩ

*Number of measurements on fully charged batteries* typ. 2200 at I min = 50 A and 0.1 s  
typ. 800 at I min = 100 A and 0.1 s

*Interference suppression* Yes

*Range* 0 - 1000 mΩ

*Range selection* Auto

*Resolution*

0 – 999 μΩ 1 μΩ

1.0 – 9.99 mΩ 0.01 mΩ

10.0 – 99.9 mΩ 0.1 mΩ

100 – 1000 mΩ 1 mΩ

*Inaccuracy*

0 – 1999 μΩ ±1 % of reading ±1 digit

2 – 1000 mΩ ±2 % of reading ±1 digit

500 – 1000 mΩ ±4 % of reading ±1 digit

**Outputs + / -**

*Range* > 100 A DC (R < 2 mΩ)

*Output voltage (max)* 2.5 V DC

*Generation duration* Selectable: 0.1 s, 0.6 s, 3 s

**Recovery time at I min set to 100 A and load 100 μΩ**

Generation time	Max	Typ
0.1 s	10 s	8 s
0.6 s	20 s	16 s
3 s	130 s	100 s

**Inputs**

*SENSE + / -*

*Connector* 4 mm banana jack

*Voltage* ±3 V DC

*Trigger input* Threshold 8 V DC

*DC IN* 12 – 24 V DC, 2 A max

**Logger**

*Logger, Data* Label, Timestamp, I max, I min, I Limit, Resistance, Meas.time, P/F limit

*Labeling schemes* Circuit breaker oriented or running numbers

*Capacity* 190 measurements

**Wireless communication**

*Headset* Bluetooth

*PC communication* Bluetooth

**ACCESSORIES**



Test cables with Kelvin probes (incl. in BD-59090)



Test cables with Kelvin clamps (incl. in BD-59092)

**OPTIONAL ACCESSORIES**



Calibration kit



Bluetooth headset



Bluetooth dongle

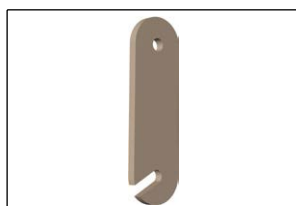

Connection plate, used together with the cable kits.



Soft carrying case

**ORDERING INFORMATION**

Item	Art. No.
<b>DLRO-H200</b> <i>Incl.</i> Charger, DLRO-H200 Win	BD-59100
<b>DLRO-H200</b> <i>Incl.</i> 2 x 1.3 m (4 ft) test cables with Kelvin probes (one with trig button) Transport case, Charger, Rubber holster, Carrying strap, Belt clip, DLRO-H200 Win	BD-59190
<b>DLRO-H200</b> <i>Incl.</i> 1.3 m (4 ft) test cable red with Kelvin clamp 3 m (10 ft) test cable black with Kelvin clamp Transport case, Charger, Rubber holster, Carrying strap, Belt clip, DLRO-H200 Win	BD-59192
<b>DLRO-H200</b> <i>Incl.</i> 1.3 m (4 ft) test cable red with Kelvin clamp 5 m (16 ft) test cable black with Kelvin clamp Transport case, Charger, Rubber holster, Carrying strap, Belt clip, DLRO-H200 Win	BD-59193
<b>Optional accessories</b>	
<b>Test cables with Kelvin probes</b> (current & sense) 2 x 1.3 (4 ft) m (one with trig button)	GA-90000
<b>Test cables with Kelvin clamps</b> (current & sense) 1.3 m (4 ft) red, 3 m (10 ft) black	GA-90001
<b>Current cable with Kelvin clamp</b> 3 m (10 ft) black, 16 mm <sup>2</sup>	GA-00372
<b>Current cable with Kelvin clamp</b> 1.3 m (4 ft) red, 16 mm <sup>2</sup>	GA-00373
<b>Current cable with Kelvin clamp</b> 5 m (16 ft) black, 25 mm <sup>2</sup>	GA-00374
<b>Current cable with Kelvin clamp</b> 10 m (33 ft) black, 16 mm <sup>2</sup>	GA-00376
<b>Cable kit 5 m</b> (for use with the std. ground connectors) Current cable 0.5 m (1.6 ft), Connection plate and sense cables 5 m (16 ft), Ground cable	GA-00380
<b>Cable kit 10 m</b> Current cable 0.5 m (1.6 ft), Connection plate and sense cables 10 m (33 ft), Ground cable	GA-00382
<b>Cable kit 15 m</b> Current cable 0.5 m (1.6 ft), Connection plate and sense cables 15 m (49 ft), Ground cable	GA-00384
<b>Bluetooth kit</b> Bluetooth headset and dongle for PC	XC-06000
<b>Calibration kit</b>	BD-90002
<b>Soft carrying case</b> For DLRO-H200, Charger and Cables	GD-00620