

# Understanding FMCW Automotive Radar

## And How to Obtain Precise Measurements for Mission-Critical Radar Devices

In this application note, we will look at frequency modulated continuous waveform (FMCW) radar technology in detail, particularly the wideband 76 - 81 GHz range. We will describe how you can use Keysight's solutions to test your designs to ensure maximum efficiency, reliability, repeatability, and most importantly, ensure that your devices work to the highest safety standards possible.

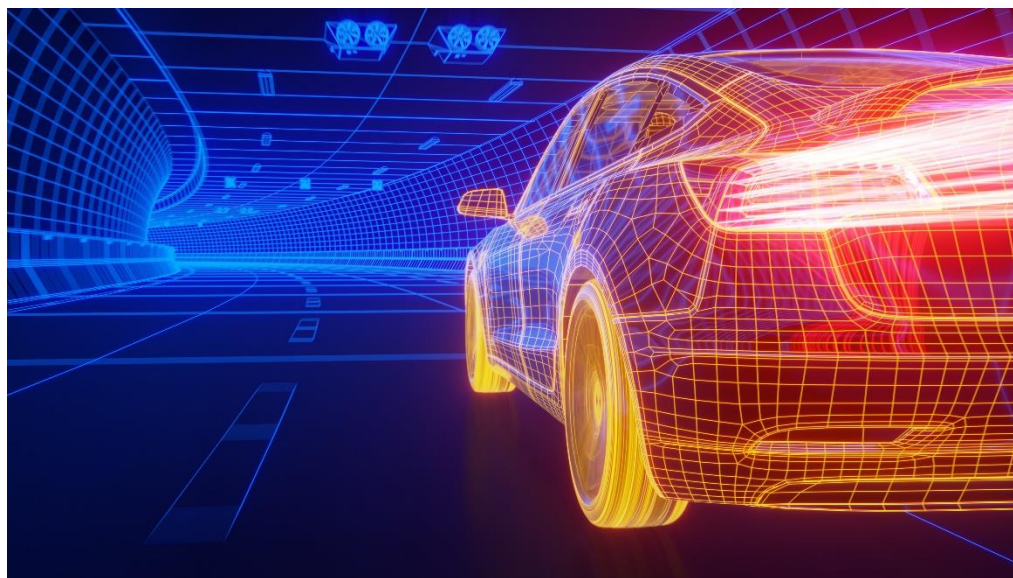

## Introduction

It is reported that 1.35 million <sup>1</sup> people die from road accidents every year, with thousands more injured. This is the main reason why radar specialists have been recruited by key players in the automotive industry, to develop automotive radar systems that not only improve car safety, but also meet key criteria such as size and cost. Because of this market demand, various radar systems, such as adaptive cruise control (ACC), stop-and-go, blind spot detection (BSD), lane change assist (LCA), and rear crash warning (RCW), are now widely used in vehicles.

Radars based on a frequency modulated continuous waveform (FMCW) is the key technology used in most automotive radar applications today. Unlike more traditional pulsed radar, FMCW radar using continuous wave modulation can avoid high peak-to-average power ratio (PAPR) in transmission, which simplifies the design process for antennas and RF components like power amplifiers. Consequently, an automotive radar system based on this technology offers more advantages, such as better performance with simplified RF components, small size, light weight, and low cost.

In this application note, we will study FMCW radar technology in a little more detail, particularly the wideband 77 - 81 GHz range, and describe how Keysight's solutions can help you test your designs to ensure maximum efficiency, reliability, repeatability and most importantly, ensure that your devices work to the highest safety standards possible. Key test parameters discussed include frequency linearity, chirp rate, phase error, power deviation and many more.



### Why are people investing now?

In a word – safety. There are millions of road deaths annually and both car makers and law makers want the future of the automobile to be safe and secure.

1. World Health Organization – Global status report on road safety 2018.

## What Is FMCW and Why Use It?

FMCW is a type of radar sensor that can continuously transmit signals like a simple continuous-wave (CW) radar. However, unlike CW radar, the operating frequency of FMCW can be changed during the measurement, therefore we can say that the transmitted signal is frequency modulated. This type of radar has been around for many years, but these days the most widely used application is within the automotive radar domain.

So why is FMCW used so widely in automotive radar? Here are the advantages:

- Potential narrow resolution allows measurement of very small ranges. The minimal measurable range is comparable to the transmitted wavelength.
- Very high accuracy of range measurements.
- Unlike pulsed radar, with FMCW you can simultaneously transmit and measure the received signal.
- Because the transmit and receive signals are “always on”, there is zero blind range. This means that there is no “blind spot” in between transmit and receive, where something could be missed.
- Pulsed radar systems have high levels of peak power; this is not the case for FMCW.
- The received signal is mixed down to lower frequencies, so the processing circuitry and algorithms need not be so complicated.
- Because of the simpler circuit design, and the capabilities of modern digital signal processors (DSPs), overall cost and the size and weight of FMCW radar modules are lower than other radar standards.

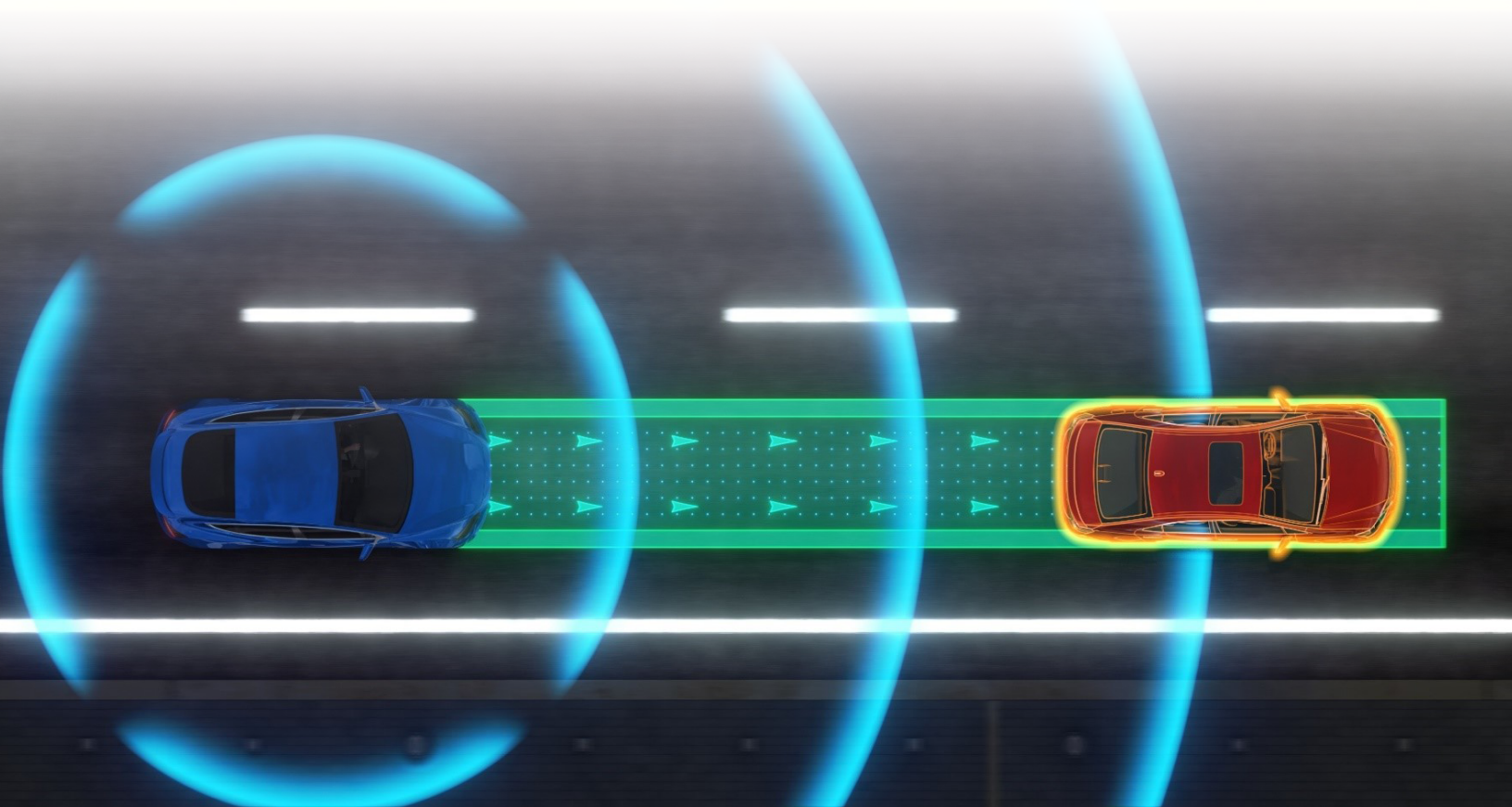

## FMCW – How does it work?

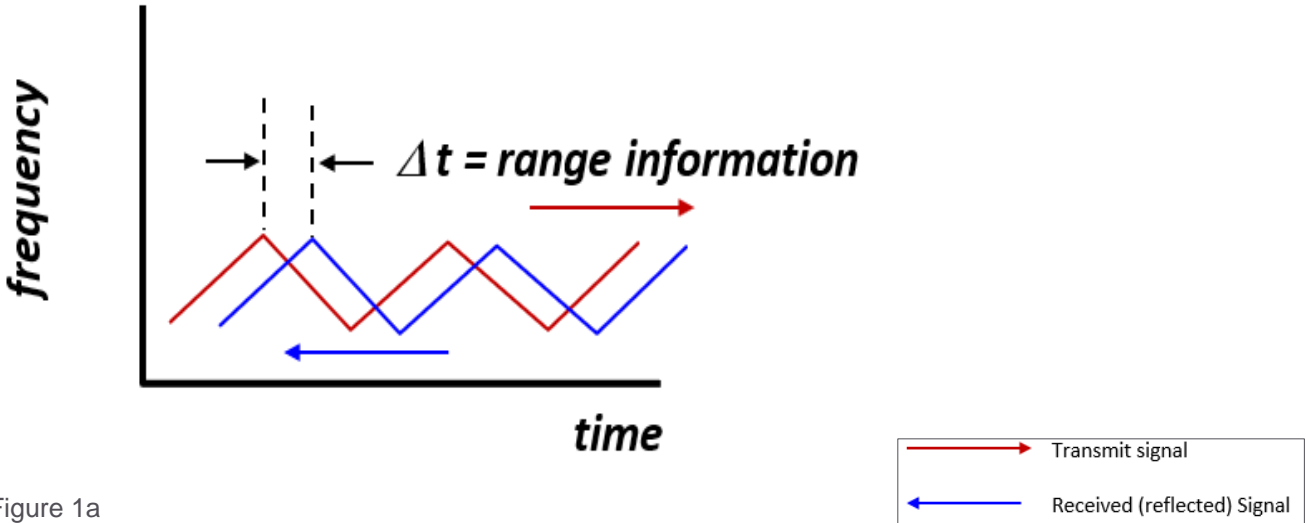

Figure 1a

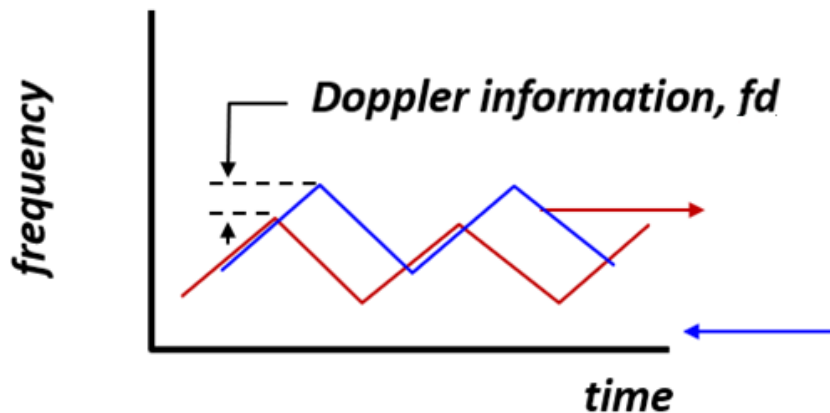

Figure 1b

Figures 1a and 1b give a visual overview of FMCW radar detection. A shift in both time and frequency between the transmit and receive signals determine range and velocity of targets.

The received signal is a time-delayed version of the transmitted signal where the delay,  $\Delta t$  (delay in time), gives the range information and  $f_d$  (delay in frequency) is the Doppler information. Because the signal is always sweeping through a set frequency band (for example 77 - 81 GHz), at any moment during the sweep, the frequency difference between the transmit and receive signals,  $f_1$  and  $f_2$ , is constant.

Both  $f_1$  and  $f_2$  are usually called the beat frequency, and there are two measurements made, both on the rising and falling edge of the signal (also called the chirp). In the case of a single target, both the rising and falling beat frequencies are required to ensure the equations can be solved unambiguously. Because the sweep is linear, we can derive the time delay from the beat frequency, and from this also calculate the range.

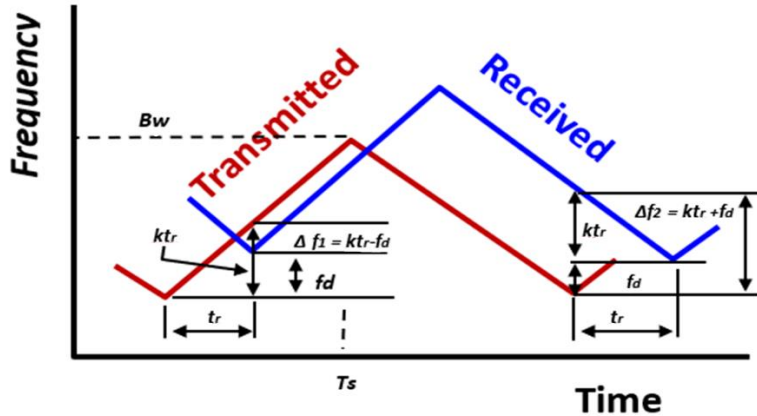

Figure 2

Figure 2 gives us a more in-depth overview of the different parameters required to make real measurements to calculate the range and velocity.

$$\Delta f_1 = ktr - fd$$

$$\Delta f_2 = ktr + fd$$

$k$  = frequency slope

$tr$  = time delay and  $ktr$  is the frequency shift due to time delay.

To calculate the Doppler shift,  $fd = (2 / \lambda c) * Vr$ , where  $Vr$  is the radial velocity of the object.

To calculate  $ktr$ ,  $ktr = ((2 / C) * (Bw / Ts)) * R$ , where  $C$  = constant,  $Bw$  is the signal bandwidth,  $Ts$  is the chirp duration and  $R$  is the range to the target.

Use the beat frequency for both the rising and falling chirp to determine the velocity and range. <sup>2</sup>

$$\Delta f_1 = ((2 / \lambda c) * Vr) - (((2 / C) * (Bw / Ts)) * R)$$

$$\Delta f_2 = ((2 / \lambda c) * Vr) + (((2 / C) * (Bw / Ts)) * R)$$

2. In multi-target scenarios, things get a little more complicated. For example, for two targets we would have two beat frequencies from each target, so four beat frequencies in total. What is not known is which of these beat frequencies are from the same target and thus belong together. In this situation, the above equations cannot be solved unambiguously and would result in four individual targets, two of which would be "ghost targets". "Ghost targets" can only be resolved by increasing the number of chirps with varying slopes.

## Key measurements

Here are the key questions you need to ask, to accurately characterize an FMCW radar signal.

1. **Is the sweep bandwidth of the signal correct?** Typical automotive radar technology works in the 24 GHz, 77 GHz and 79 GHz frequency bands, and each of these can have a different sweep bandwidth. For example, at 24 GHz, we typically see bandwidths in the order of 100's of MHz, where at the higher frequencies, bandwidths can be 1 GHz and greater. A traditional swept-tuned spectrum analyzer can sweep across the entire band to view the envelope of the signal.
  - a. **Why a larger bandwidth at higher frequency bands?** Greater bandwidths allow finer resolution, thus allowing much better target separation capability. Using higher center frequencies also increases the Doppler resolution. Therefore, automotive radar standards are moving from 24 GHz to 77/79 GHz.
2. **Validate the linearity of the FM sweep.** Since FMCW is comprised of a frequency sweep, the linearity of that sweep is important. Any ripples or anomalies with the sweep can cause a degradation in the accuracy and resolution of the range and radial velocity.
3. **Measure the chirp length and chirp rate.** The chirp length and rate affect the ability to determine the radial velocity. Due to possible “ghost targets”, multiple chirps are analyzed to give greater measurement confidence.
4. **What about signal power?**

## System Validation – How Does It Work?

Effective radar system design requires comprehensive system validation – a time-consuming and expensive process. Radar engineers are not only required to validate the radar transmitter performance (signal analysis) but also need to test the radar receiver performance. Radar receivers must be tested with realistic threats, sensitivity and jamming scenarios. Generating ultra-wideband (UWB) signals with Doppler frequency offsets, target echoes and clutter to perform receiver verification can be challenging. Designing and testing UWB radar systems requires a variety of signal sources, target environment setups and measurements. Carefully designed and optimized waveforms are essential to ensure excellent real-world performance.

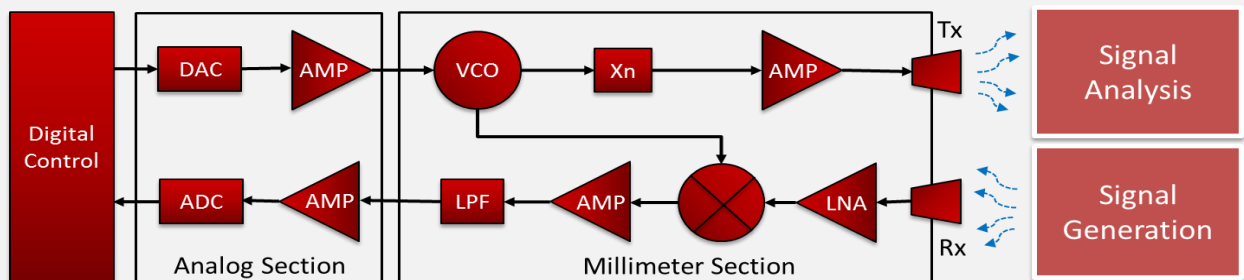

Figure 3. FMCW automotive radar FMCW block diagram

## Signal Generation

Before we show a measurement, we want to show how you can use Keysight signal generators to create an FMCW signal. This is useful if you do not have multiple devices available to test, or if you want to create a signal interference solution to allow testing of your devices in the presence of other (not necessarily FMCW) signals.

In this section, we will introduce signal generation using a Keysight M8195A arbitrary waveform generator (AWG), and then show how you can use option BHP of Keysight's VSA (vector signal analysis) software to analyze FMCW radar signals. Option BHP is a dedicated option for FMCW signal types and allows easy setup and detection of these signals. While there are multiple configurations available for automotive radar analysis with Keysight, we will be using option 060 which includes the Keysight N9041B, 2 Hz to 110 GHz spectrum analyzer to capture the signal. This allows us to capture the signal without using any external mixing, thus maintaining the highest signal integrity.

The signal generation configuration consists of the three instruments below:

- M8195A 65 GSa/s Arbitrary Waveform Generator
- N5183B MXG Microwave Analog Signal Generator, 9 kHz – 40 GHz
- N9029ACST-U12 WR12 VDI compact Upconverter



Figure 4. Receiver verification instrument setup

Channel 1 Data Out on the M8195A is connected to the intermediate frequency (IF) input of the N9029ACST-U12 via a 6-dB attenuator pad, while the Channel 1 Complement Data Out is terminated with a 50 Ohm load. The IF input power is recommended to be kept at < -15 dBm for linear region operation.

The local oscillator (LO) signal is provided by N5183B analog signal generator. The N9029ACST-U12 upconverter requires a LO frequency that is half of the carrier frequency  $F_c$ , thus users can select the LO frequency in the range of 30 – 45 GHz.

A simplified block diagram of the system is shown in the figure below. M8195A AWG provides an IF signal to be mixed with a fixed LO signal from the MXG to produce a millimeter wave signal. The up-conversion process generates a millimeter wave signal with both upper and lower sideband spectrum. The mixing product is either  $F_c - F_{IF}$  (lower sideband) or  $F_c + F_{IF}$  (upper sideband), therefore a bandpass filter is needed to remove the unwanted mixing signal. In this example the IF signal is a linear frequency sweep from 2 GHz – 6 GHz and is mixed with the LO signal at frequency 75 GHz ( $37.5 \text{ GHz} \times 2$ ) to produce a 77 - 81 GHz FMCW radar signal. As radar signals at the lower 24 GHz frequency range are still widely in use, the same instrumentation can be used at this lower frequency.

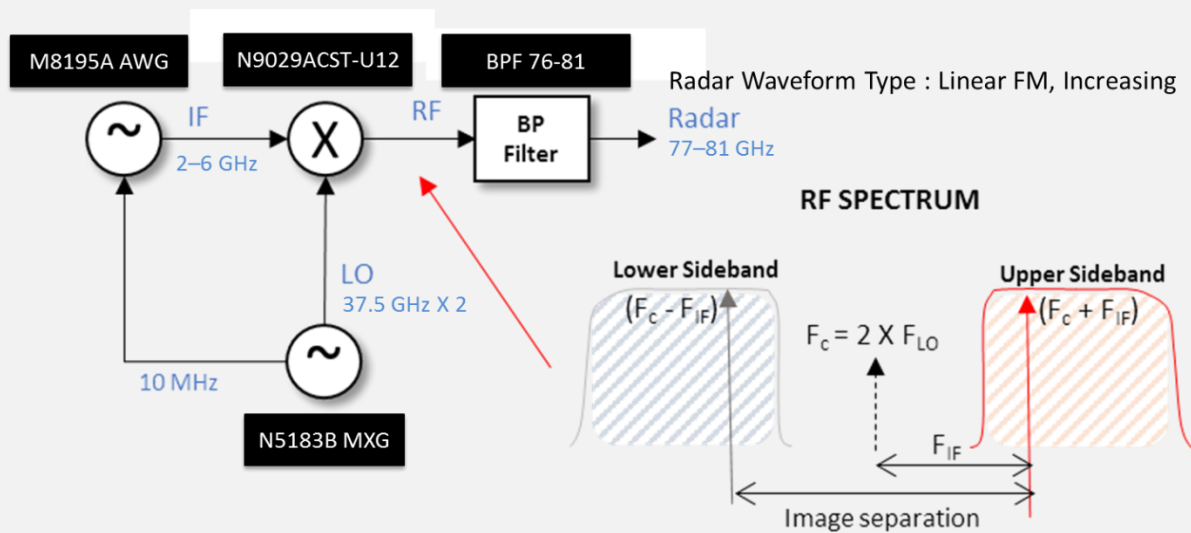

Figure 5. Block diagram of the receiver validation measurement setup

## Why an AWG Is Used In Modern IF Signal Generation?

Older 24 GHz generation radars only required bandwidths in the MHz range which are possible to create using the internal wideband generation capabilities of traditional RF vector signal generators. Modern automotive radar applications require continually increasing modulation bandwidths such as 79 GHz radar applications in pedestrian detection or autonomous emergency braking in urban areas. These applications require better resolution and better object distinction. Traditional RF signal generators offer good signal purity but are typically too limited in their modulation bandwidth to support these new wideband requirements. Therefore, a high precision arbitrary waveform generator (AWG) is used to generate IF signals in this configuration. Although an AWG has less dynamic range compared with RF signal generator, it offers several significant benefits which make it a preferable choice for IF signal generation.



An AWG offers an extremely wide modulation bandwidth without compromising on the signal fidelity and distortions. In the case of Keysight's M819xA AWGs, it is possible to create signals with up to 25 GHz bandwidth. 79 GHz automotive radar signals typically have a 4 - 5 GHz bandwidth for better distance resolution detection, hence the new requirement for higher performance, digital equipment as opposed to vector signal generators.

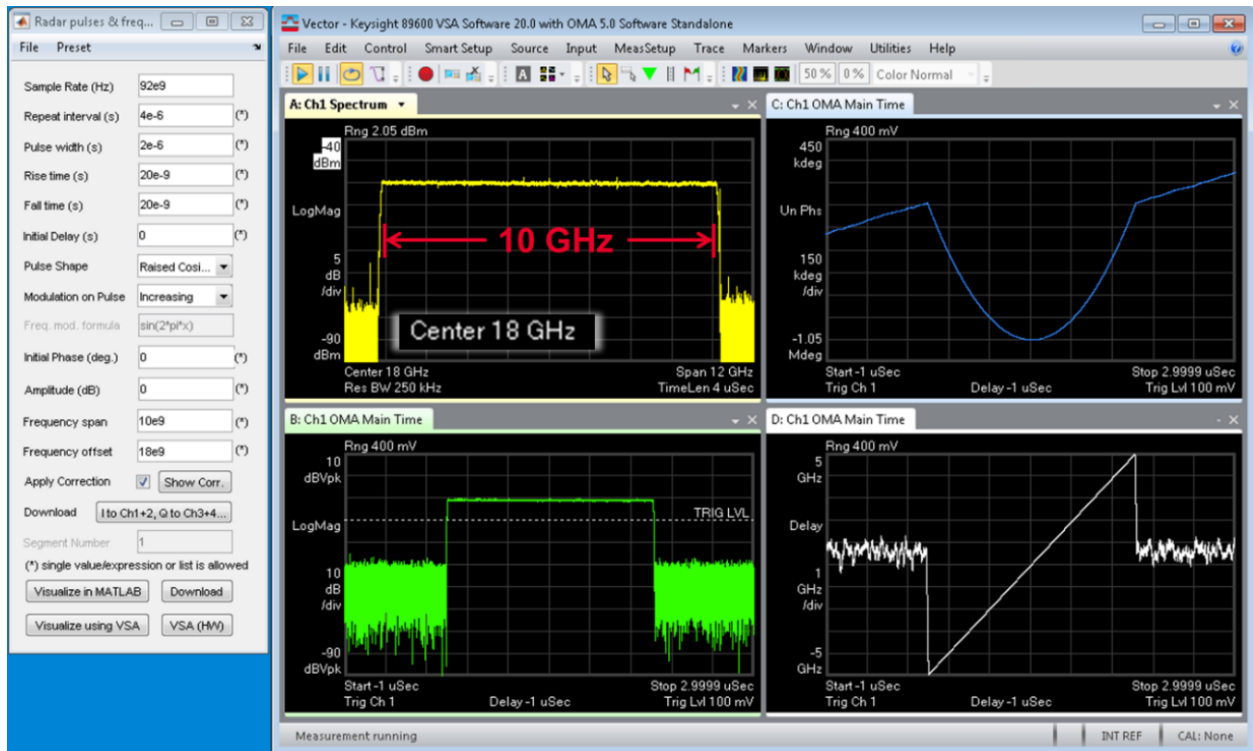

Figure 6. Wide modulation bandwidth shown on a Keysight AWG

Another interesting capability of an AWG is instantaneous frequency hopping. Unlike a traditional signal generator, an AWG can switch between frequencies almost instantaneously – the effective switching time is a single cycle of the generated frequency.

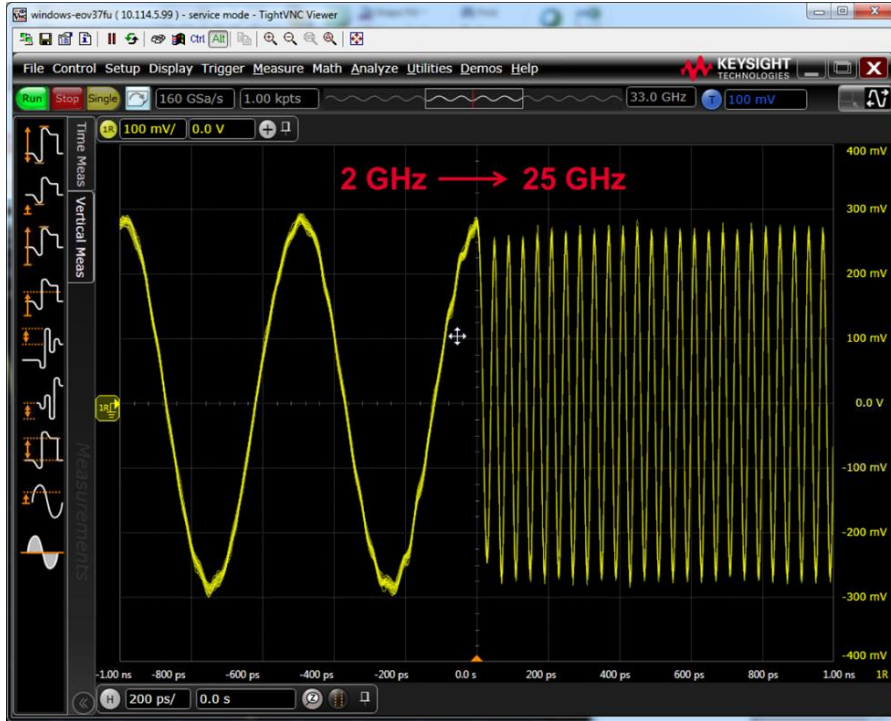

Figure 7. A waveform where frequencies are switched from 2 GHz to 25 GHz with less than 5 0ps

Complex modulated signals can be found in today's automotive radar technologies, although the most common waveform is FMCW. The rapid evolution of modulation schemes and coding systems requires the signal generators to be able to supply multiple standard signals so receiver designs and components can be properly validated. An AWG is an ideal solution as it can provide multiple flexible modulation formats including CW, FMCW, PMCW, LFM chirp, Barker, non-linear chirp and even user-defined frequency and phase modulation.

Any mathematical expression can be used to describe the modulation on the pulse

Incl. CW, FMCW, LFM chirp, Barker, non-linear chirp, user-defined frequency- and phase modulation

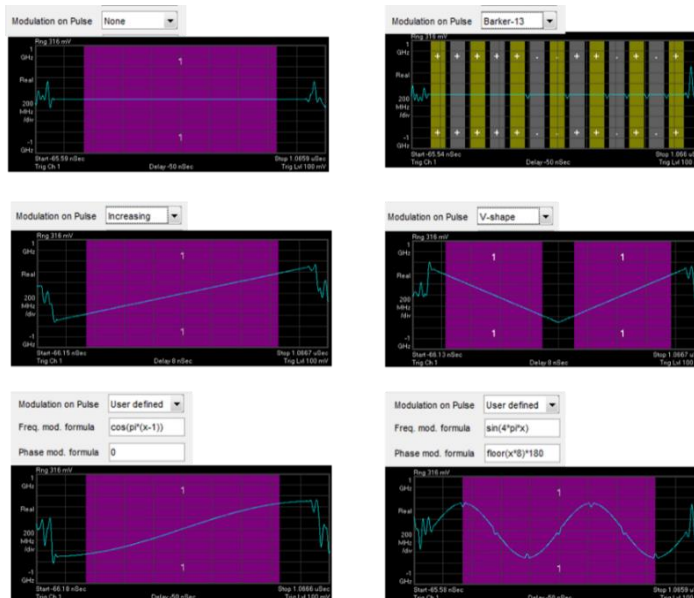

Figure 8. The flexibility of an AWG

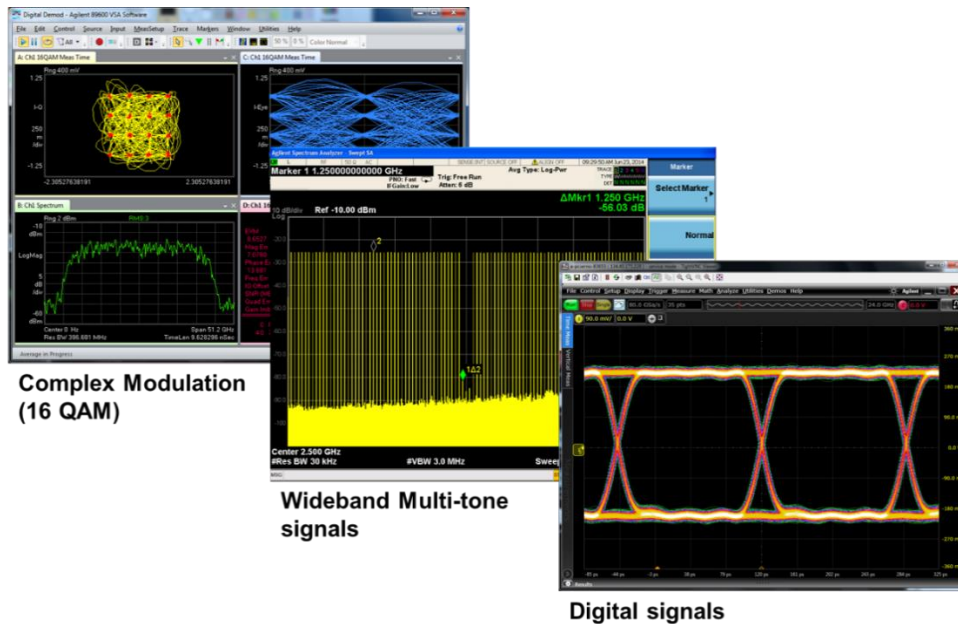

Figure 9. Examples of other signals that can be generated

Finally, waveforms in AWGs are calculated mathematically, therefore we can calibrate the frequency and phase response. If the frequency response of the AWG plus the channel is known, it can be de-embedded from the signal. Keysight's method is to use multitone signals to measure the relative amplitude response of the system. It then utilizes this information to pre-distort the generated waveform so that the resulting waveform at the output of the system is corrected and has a flat response as shown in the figure below.

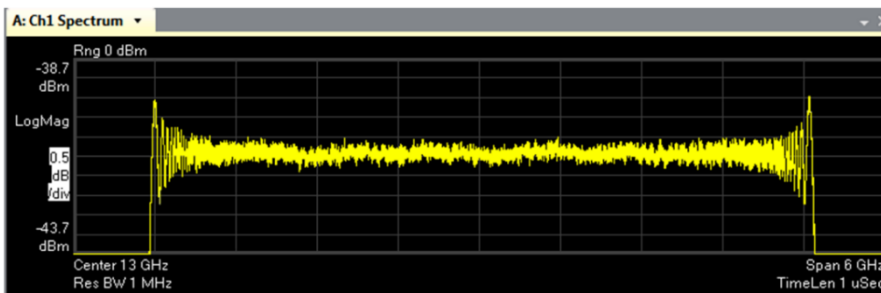
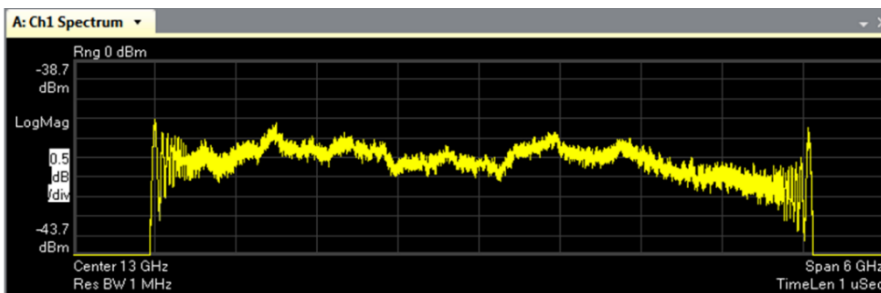

Figure 10. Create stable, flat, wideband signals with built-in frequency correction

The table below summarizes the comparison between high speed AWGs and signal generators.

High speed AWG	Signal generator
Extremely wide modulation bandwidth	Higher signal fidelity for narrow-band signals
Instantaneous frequency hopping	Better out-of-band spur suppression
Multi-emitter pulse generation with overlapping pulses at different frequencies	Better phase noise performance
Synchronized multi-channel pulse generation	Wider output power range
Repeatable phase from pulse-to-pulse and channel-to-channel	Carrier frequency adjustable without waveform re-calculation
Flexible modulation formats	External modulation inputs
Frequency and phase response can be calibrated to be flat – even with very wide modulation bandwidth	Additional features such as ALC

## Signal Analysis

The Keysight Vector Signal Analyzer (VSA) software is a powerful software tool to demodulate and analyze signals. There are libraries available for 5G, automotive radar, and many other signal standards. The VSA software is hardware agnostic and can be used with multiple different types of Keysight instrumentation, including X-series signal analyzers and oscilloscopes, as well as offline use when needing to analyze previously saved waveform captures.

## Vector Signal Analysis – How Does It Work?

Much of the information in this section can be found in the Keysight “Vector Signal Analysis Basics” application note, publication number [5990-7451EN](#). For detailed explanations of vector signal analysis and its theory please go to this app note.

Analog, swept-tuned spectrum analyzers use super-heterodyne technology to cover wide frequency ranges; from audio, through microwave, to millimeter wave frequencies. Fast Fourier transform (FFT) analyzers use digital signal processing (DSP) to provide high-resolution spectrum and network analysis. Today’s wide-bandwidth, vector-modulated (also called complex or digitally modulated), time-varying signals benefit greatly from the capabilities of FFT analysis and other DSP techniques. VSA provides fast, high-resolution spectrum measurements, demodulation, and advanced time-domain analysis. VSA is especially useful for characterizing complex signals such as burst, transient, or modulated signals used in communications, video, broadcast, radar, and software-defined radio applications.

Figure 11 shows a simplified VSA block diagram. VSA implements a very different measurement approach than traditional swept analysis; the analog IF section is replaced by a digital IF section incorporating FFT and digital signal processing algorithms. Traditional swept-tuned spectrum analysis is an analog system; VSA is fundamentally a digital system that uses digital data and mathematical algorithms to perform data analysis. VSA software accepts and analyzes digitized data from many measurement front ends, allowing you to troubleshoot throughout the system block diagram.

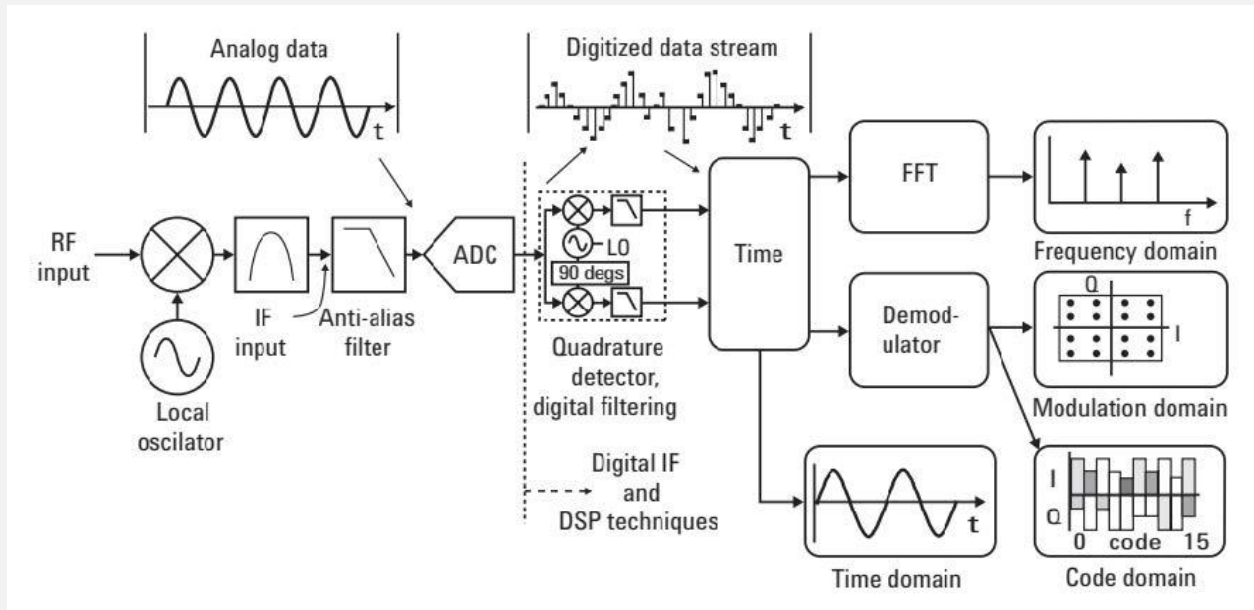

Figure 11. A simplified VSA block diagram

The vector signal analysis process requires a digitized analog input signal and then uses DSP technology process and provide data outputs; the FFT algorithm produces frequency domain results, the demodulation algorithms produce modulation and code domain results.

In Figure 12 below, we show a more Keysight-specific approach to the DSP techniques, including the following fundamental measurement stages:

No.	Measurement front-end	No.	VSA software
1	Signal conditioning with frequency translation. Depending on the front-end hardware used, different signal conditioning steps may be needed and/or available.	4	Digital filtering and resampling
2	Analog-to-digital conversion	5	Data windowing
3	Quadrature detection	6	FFT analysis (for vector modulation, blocks 5 and 6 are replaced with the demodulator block)

The first stage of the measurement process is called signal conditioning. This stage includes several important functions that condition and optimize the signal for the analog-to-digital conversion and FFT analysis. The first function is AC and DC coupling. This option is necessary if you need to remove unwanted DC biases in the measurement setup. Next, the signal is either amplified or attenuated for optimal signal level into the mixer. The mixer stage provides frequency translation, or RF-to-IF downconversion, and mixes the signal down to the final IF. This operation is the same as the super-heterodyne function of swept-tuned analysis and extends FFT analysis capabilities through the microwave frequency range. In practice, it may take several downconversion stages to reach the final IF frequency. Some signal analyzers provide external IF input capability; by providing your own IF, you can extend the VSA's upper frequency range to match a receiver you provide.

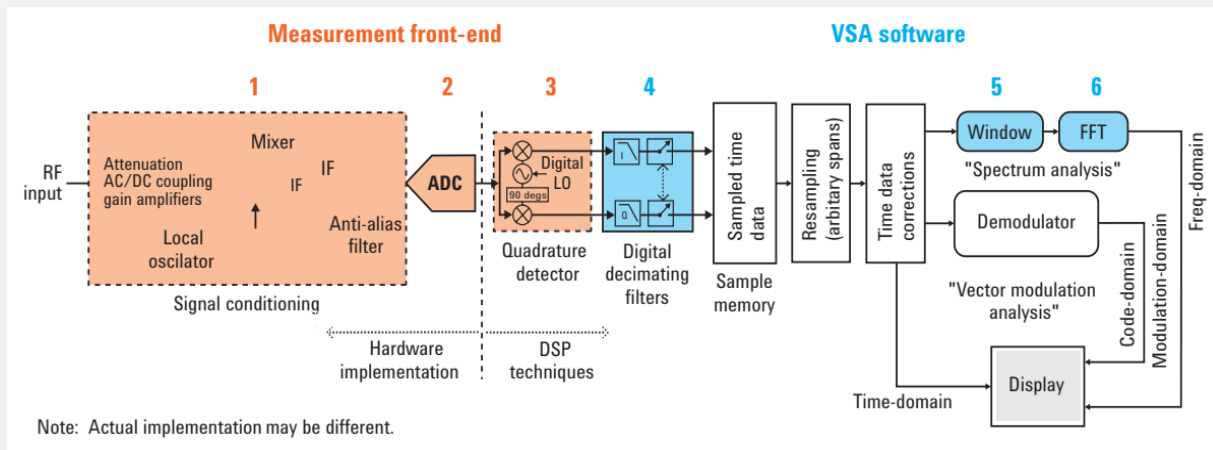

Figure 12. Simplified block diagram showing RF hardware front end and vector signal analysis software

Using the above techniques and more that can be found in the full VSA application note, we can make measurements on a complex, wideband signal such as 4 GHz automotive radar signals using a Keysight UXA series spectrum analyser as the “measurement front end”, with the VSA software taking care of the DSP techniques.

## Automotive Radar Automation

One portion of our solution that we have not spoken about yet is the KS83200A Automation Software for Automotive Radar. This is a Keysight Pathwave Test Automation Platform (TAP) based software that can sit on a separate Windows PC or on any Windows based instrument in your measurement setup. This is a test management suite which can be used to control all hardware and software in your setup, from hardware connections and control, to connecting to appropriate software such as VSA to make one-click measurements.

In addition to simpler setups, many standards bodies including the European Telecommunications Standards Institute (ETSI) are working towards conformance and compliance testing for radar devices which require specific instrument setups for each test. Because the KS83200A can control and setup multiple instruments, setting up your Keysight signal analyzer or signal generator to make measurements is made much simpler as the instrument setups for all ETSI standards <sup>3</sup> are built-in, so it is a one-click setup to enable compliance testing. Below you can see a list of some of the ETSI tests available. It simple takes one click to add them to your test plan, and then running the TAP software automates the instrument setup.

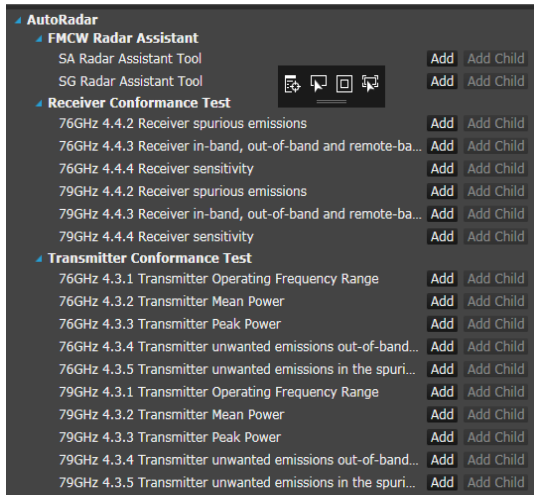

Figure 13a. Easy-to-see lists of ETSI-based tests with automated instrument setup

The figures below show how the KS83200A software gives a clear diagram of the hardware setup, depending on the Keysight automotive radar solution configuration. You can also see that the software is capable of controlling the generation hardware including an AWG, signal generator and radar target simulator.

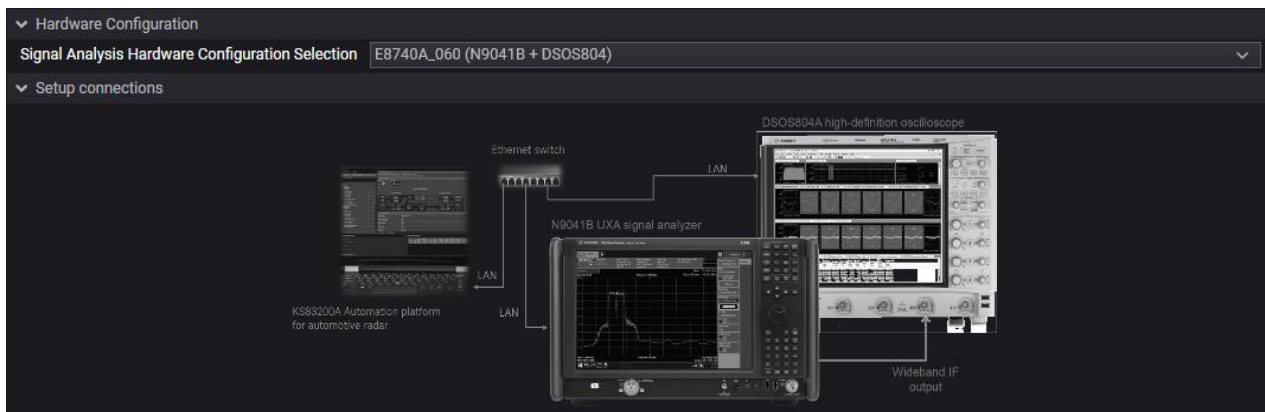

Figure 13b. Analysis measurement hardware setup example

3. As of March 2020.

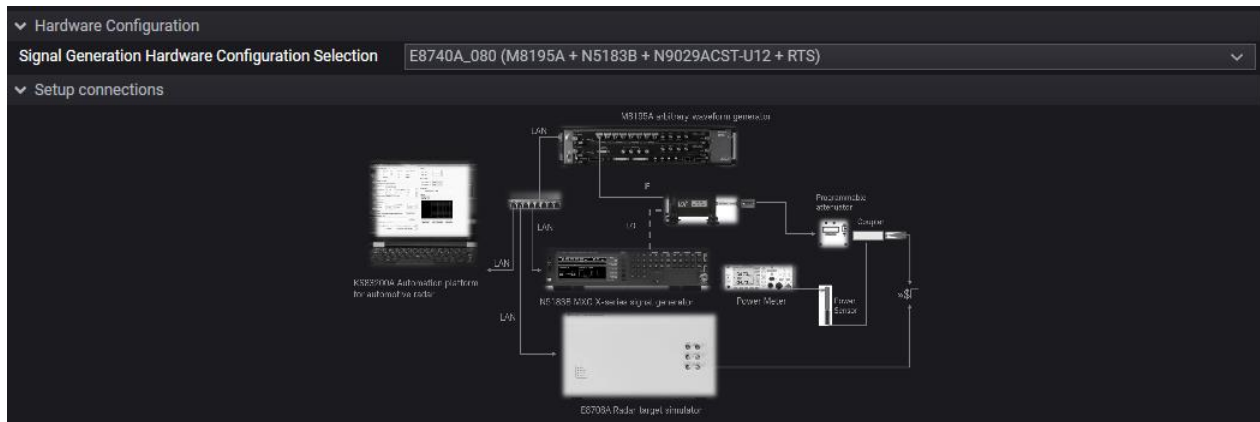

Figure 13c. Signal generation hardware setup example

## Measurement Example

For more in-depth information on how to set up this measurement, please refer to the [E8740A start up guide](#). As mentioned in the radar generation section, there are multiple configurations available, all of which are highlighted in great detail in the above configuration guide, but for this measurement, we will use E8740A-060 which is based on the Keysight N9041B UXA series signal analyzer plus DSOS604A oscilloscope.

The N9041B, has an internal analysis bandwidth of 1 GHz. However, as future radar modules are expected to have up to 4 GHz of bandwidth, this instrument has the capability to route this wideband IF signal external to an oscilloscope of appropriate bandwidth. The VSA software can be used to control the oscilloscope to perform the measurements.

The measurement instrumentation used in this section includes, and is grouped as part number E8740A-060:

- Keysight N9041B UXA signal analyzer
  - Option-H1G, 1 GHz Analysis Bandwidth
  - Option-CRW, Wideband (> 5 GHz) IF out connector
- Keysight D/MSOS804A Oscilloscope
  - Option 400
- Keysight 89600 series Vector Signal Analyzer (VSA) software
  - Keysight 89601200C, Basic vector signal analysis and hardware connectivity
  - Keysight 89601BHPC, FMCW radar analysis option
- Keysight KS83200A Automation Software for Automotive Radar



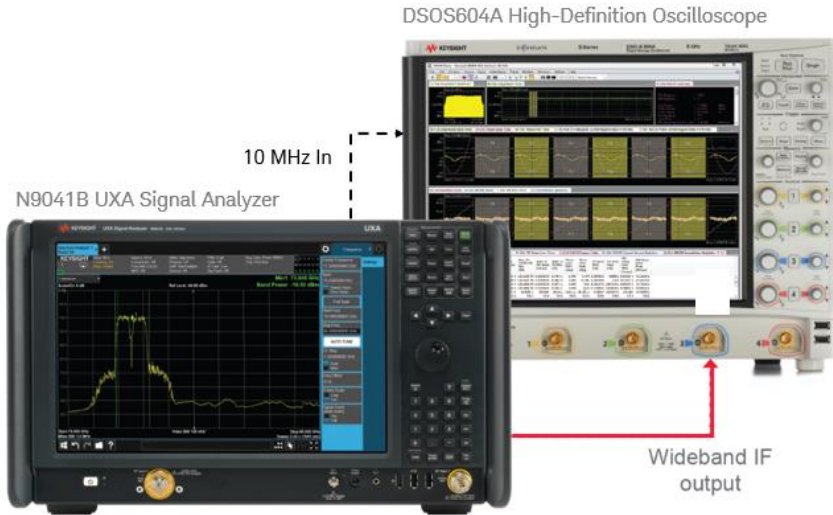

Figure 14. Configuration of the analysis solution

The sample signal to be measured is a repeating FMCW modulation signal pattern consisting of multiple repeating linear FM (LFM) up-chirps. The signal comprises of a repeating pattern of LFM up-chirps deviating from -500 MHz to +500 MHz relative to the center frequency (1 GHz total deviation) over a 90 usec time interval. The power level remains on constantly, and there is no time gap in between each successive LFM up-chirp occurrence.

The main software component of this solution is the powerful Keysight VSA software, used in conjunction with option BHP (FMCW radar analysis option) which contains the measurement algorithms that will be used to make measurements on the FMCW signals.

The power of VSA is highlighted in the initial setup screen that you can see in the screen capture below.



Figure 15. One VSA capture provides information for multiple simultaneous measurements

## 1. Acquisition Spectrum

You can see that we have a spectrum display in the upper left of Figure 15 showing the bandwidth, along with start and stop frequencies. This first measurement is akin to a standard swept-tuned spectrum analysis measurement, where we can use markers to determine the swept bandwidth of the signal. This enables a check that the occupied bandwidth of their signal is as it should be. This measurement can be made on a signal analyzer, a direct input into an oscilloscope, or feeding the signal into an oscilloscope from the wideband IF output of a signal analyzer, as we are doing in this example. Alternatively, the VSA software can make this measurement remotely from a previously recorded signal.

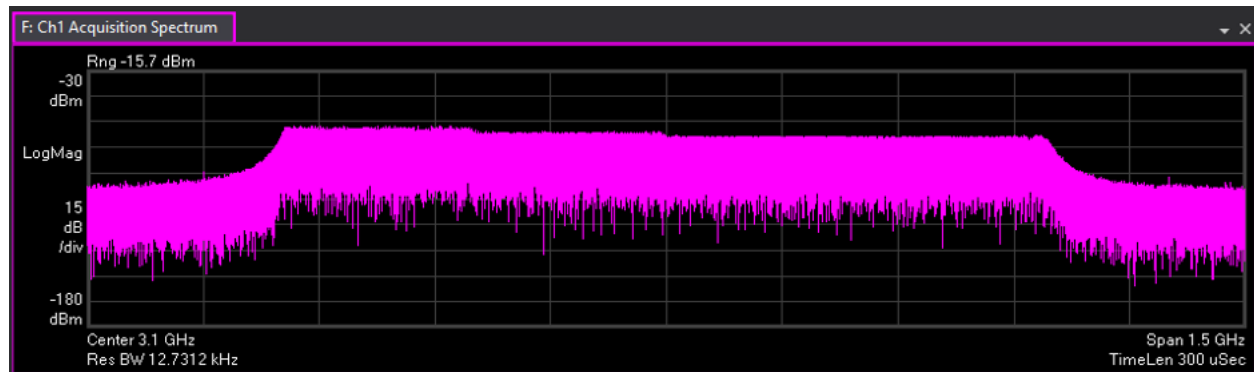

Figure 16. Spectrum display

## 2. Acquisition Time

Next to this you can see an example that highlights VSA's additional capabilities. As VSA is a time-sampled system, you can view the signal behavior over a set time. As seen in the figure below, VSA software with the FMCW analysis option automatically detects each sweep region and labels them accordingly. In this example we see six regions, but the capability is auto detected as required. This view is useful for measuring how the amplitude of your signal varies over time, enables you to gain greater insights into the power output profile of your device, and can allow you to see and define the shape of the signal in the time domain.

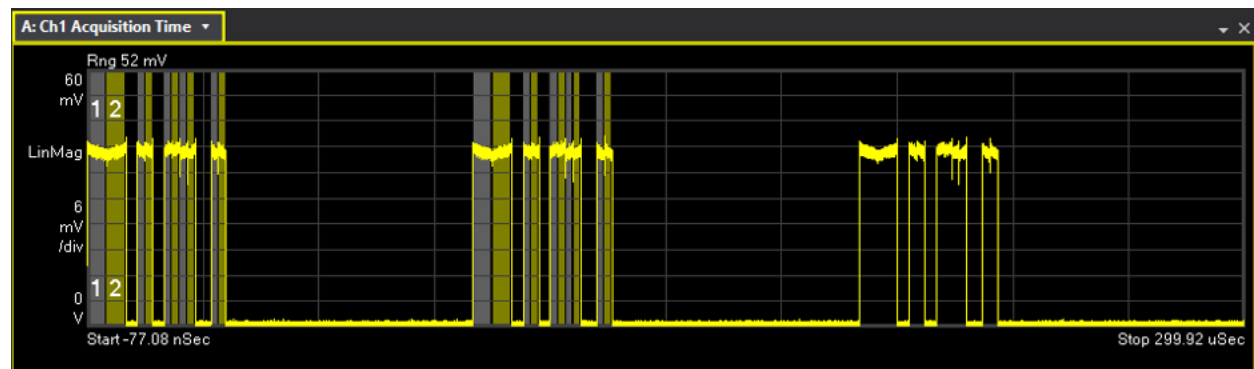

Figure 17. Acquisition time

### 3. Further Views

In the remaining views you can see many of the key measurements that were mentioned, also being made simultaneously. For example, in section 3 we can show how frequencies deviate over time. These measurements are particularly important as radar device manufacturers will have specifications that they must meet for frequency sweep time and FM linearity, and at times it is also important to be able to correlate between different results' views, which is possible within VSA. For example, you can place a marker on a "FM vs time" plot, a marker on a "phase vs time" plot, then these markers can be linked to each to give you an insight in to how your signal is behaving in different domains.

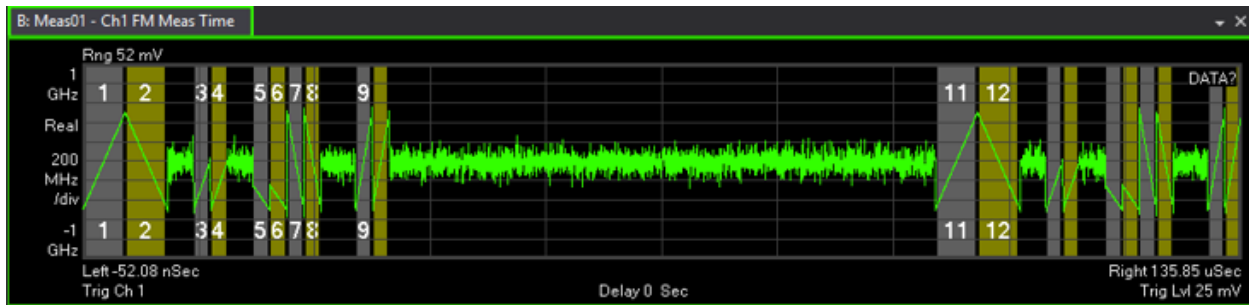

Figure 18. FM vs. time

The final indicators give you statistical information about your signals. You can see in the images below a view called FMCW Region Table, which gives you detailed information on your signal. Parameters such as the mean power, time length of each FMCW sweep and phase/FM error can be easily viewed with the added option of being able to download the data for your records.

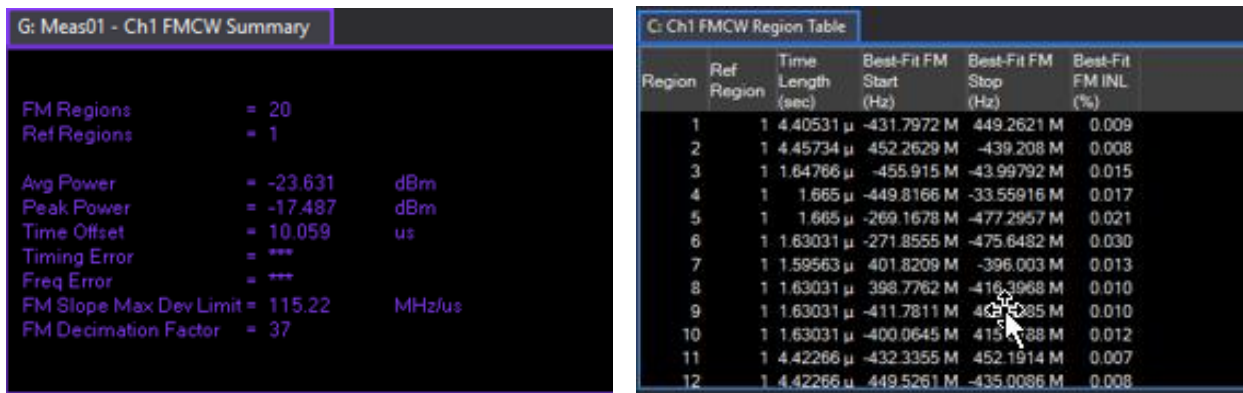

Figure 19. FMCW summary information (left) and FMCW region table (right)

## Summary and Conclusion

In this application note, we have discussed the modulation schemes and technologies currently being used within the automotive radar space. We gave an overview of the automotive radar signal generation and analysis solutions available from Keysight and a quick snapshot into the capabilities of the VSA software. Using VSA in conjunction with the Keysight N9041B UXA signal analyzer and S-series oscilloscope ensures that your device is working correctly, and also adheres to the strictest tolerances, giving multiple insights to many signal parameters that can affect the end quality of the radar device. Keysight's patented measurement science enables the performance of all the above-mentioned instruments, whether used separately or in tandem, ensuring your time is spent measuring the parameters of your device and not the specifications of your test equipment.

We also discussed the Keysight signal generation capabilities and the flexibility an AWG gives us: wide bandwidth and multi-channel signal generation which, when used in conjunction with the analysis solution and a radar target simulator, can be used for lab-based interference testing using the AWG to create real world signals.

Finally, we spoke about the KS83200A software which can be used to control all hardware and software in your setup, from hardware connections and control, to connecting to appropriate software such as VSA to make one-click measurements. In addition, many standards bodies including the European Telecommunications Standards Institute (ETSI) are working towards conformance and compliance testing for radar devices which require specific instrument setups for each test – these test setups are one-click setups allowing for less setup time, and more time to test.

Keysight's solutions enable you to test your designs to ensure maximum efficiency, reliability, repeatability, and most importantly, ensure that your devices work to the highest safety standards possible. In a world where safety is of the utmost importance, working with Keysight can ensure you achieve maximum reliability with confidence.

Learn more at: [www.keysight.com](http://www.keysight.com)

For more information on Keysight Technologies' products, applications or services, please contact your local Keysight office. The complete list is available at: [www.keysight.com/find/contactus](http://www.keysight.com/find/contactus)

