

Signal Studio for WLAN 802.11a/b/g/j/p/n/ac/ah/ax

N7617B

- Create Keysight validated and performance optimized reference signals compliant with the IEEE 802.11a/b/g/j/p/n/ac/ah/ax standards
- Use basic options to provide partially-coded signals for testing components such as power amplifiers
- Use advanced options to provide signals with full channel coding, flexible configuration of MAC headers, spatial stream mapping, and application of channel models for testing receivers
- Support MIMO testing with up to 8 streams/antennas
- N7607B Signal Studio for DFS Radar Profiles enables creation of FCC, ETSI, Japan MIC, Korean or Chinese radar test signals for DFS test
- Accelerate the signal creation process with a user interface based on parameterized and graphical signal configuration and tree-style navigation

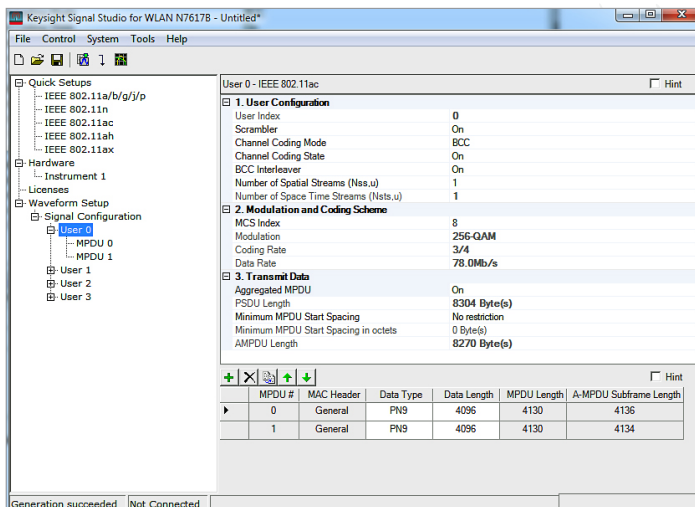

Simplify WLAN Signal Creation

Keysight Technologies, Inc. Signal Studio software is a flexible suite of signal-creation tools that will reduce the time you spend on signal simulation. For WLAN, Signal Studio's performance-optimized reference signals—validated by Keysight—enhance the characterization and verification of your devices. Through its application-specific user-interface you'll create standards-based and custom test signals for component, transmitter, and receiver test.

Component and transmitter test

Signal Studio's basic capabilities use waveform playback mode to create and customize waveform files needed to test components and transmitters. Its user-friendly interface lets you configure signal parameters, calculate the resulting waveforms and download files for playback.

The applications for these partially-coded, statistically correct signals include:

- Parametric test of components, such as amplifiers and filters
- Performance characterization and verification of RF sub-systems

Receiver test

Signal Studio's advanced capabilities enable you to create fully channel-coded signals for receiver packet-error-rate (PER) analysis. Applications include:

- Performance verification and functional test of receivers, during RF/baseband integration and system verification
- Coding verification of baseband subsystems, including FPGAs, ASICs, and DSPs

Performance test

N7617B Signal Studio for WLAN 802.11a/b/g/j/p/n/ac/ah/ax and N7607B Signal Studio for DFS Radar Profiles can be integrated to set up a test system for WLAN performance tests including DFS test.

Typical Measurements

Test components with basic capabilities:

- IMD/NPR
- ACLR
- CCDF
- EVM
- Modulation accuracy
- Channel power
- Occupied bandwidth

Verify receivers with advanced capabilities:

- Sensitivity
- Maximum input level
- Adjacent and nonadjacent channel rejection
- Clear channel assessment

Component and Transmitter Test



Figure 1. Typical component test configuration using Signal Studio's basic capabilities with a Keysight X-Series signal generator and an X-Series signal analyzer.

Signal Studio's basic capabilities enable you to create and customize a variety of WLAN 802.11 waveforms including 802.11a/b/g/j/p/n/ac/ah/ax to characterize the power and modulation performance of your transmitter or receiver components, such as amplifiers and IQ modulators. Easy manipulation of a variety of signal parameters, including standard format, transmission bandwidth, guard interval, data rate, and modulation type, simplifies signal creation.

- Create spectrally-correct signals for channel power, ACP, spectral mask, and spurious testing
- Set parameters such as channel bandwidth and modulation and coding scheme (MCS) for modulation verification and analysis, such as EVM tests
- Configure up to three 802.11a/b/g/j/p carriers with individual channel parameters such as data rate, modulation type, payload data, PN data seed value, and frequency offset
- The 802.11ac option provides a downclocking ratio parameter to allow creation of signals proposed by IEEE 802.11af.
- View CCDF, spectrum and time domain graphs to investigate the effects of modulation formats, power changes, filtering, and other effects on the test signal

Apply your signals in real-world testing

Once you have set up your signals in Signal Studio, you can download them to a variety of Keysight instruments and software platforms. Signal Studio software complements these platforms by providing a cost-effective way to tailor them to your test needs in design, development and production test.

- Vector signal generators
 - X-Series: MXG and EXG
 - PSG
 - ESG
 - First-generation MXG
 - M9381A PXIe VSG
- M9420A/M9421A PXIe vector transceiver
- PXB baseband generator and channel emulator
- M8190A arbitrary waveform generator
- DigRF exerciser module
- SystemVue simulation software
- Waveform Creator software
- E6630A wireless test set

Receiver Test

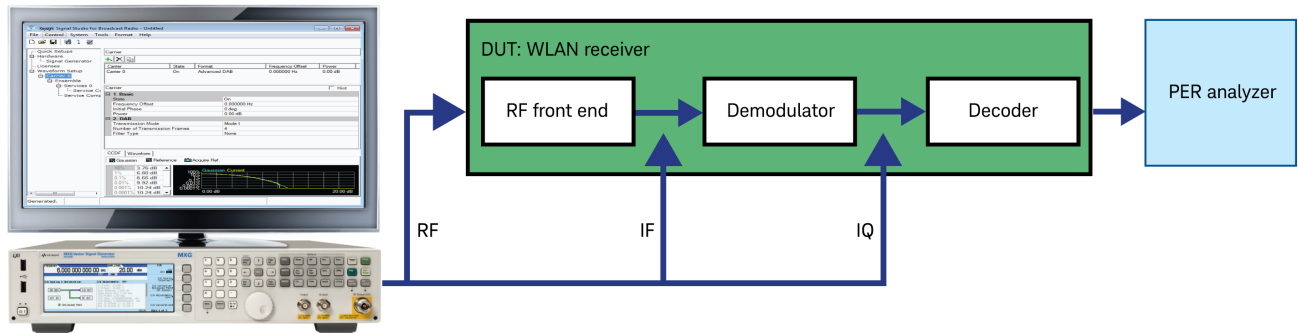

Figure 2. Generate fully channel-coded signals to evaluate the PER of your receiver with Keysight X-Series signal generators and Signal Studio's advanced capabilities.

Signal Studio's advanced mode capabilities provide additional features to help you create IEEE 802.11 WLAN standard-compliant signals for testing receiver designs in all stages of development. Use the baseband signal to perform demodulation and decoding verification on ASIC and DSP chips. To thoroughly test the demodulation capabilities of a receiver, a fully-coded test signal is necessary. This level of coding enables you to determine if each functional stage of a receiver is operating correctly and enables you to use this test signal to perform PER measurements.

- Enable or disable channel coding, scrambling and interleaving
- Configure MAC header settings, MAC FCS, sequence control, data type, and data length
- A multi-frame waveform with an incrementing Sequence Control field can be created for PER testing
- For the 802.11n, 802.11ac, 802.11ah and 802.11ax options, the software also supports Aggregation MPDU mode and LDPC encoding
- Test MIMO receivers with up to 4 antennas for 802.11n and 802.11ah or up to 8 antennas for 802.11ac and 802.11ax (hardware dependent). Choose the number of transmit chains and space-time streams, and select direct mapping or configure a spatial expansion matrix. The effects of fading can also be incorporated into a longer waveform file with MIMO channel modeling. Users can choose one of the 802.11n or 802.11ac channel models (A through F), or select a user-defined channel model. A beamforming matrix can be added for 802.11ac.
- Support 802.11ax OFDMA testing with configuration of different number and location of allocated Resource Units (RU) in the 20/40/80/80+80/160 MHz signal bandwidths. For each RU, the user can further configure Single-User or Multi-User MIMO and the spatial mapping will be applied at the RU level instead of the entire signal bandwidth.

Features Summary

802.11 WLAN	Component & transmitter testing		Receiver testing	
	Basic waveform playback mode		Advanced waveform playback mode	
802.11a/b/g/j/p				
Modulation types				
OFDM	<input type="checkbox"/>		<input type="checkbox"/>	
DSS-OFDM	<input type="checkbox"/>		<input type="checkbox"/>	
DSSS/PBCC/CCK	<input type="checkbox"/>		<input type="checkbox"/>	
ERP-PBCC	<input type="checkbox"/>		<input type="checkbox"/>	
Data source types: all 0s, PN9, PN15, user-defined file	<input type="checkbox"/>		<input type="checkbox"/>	
PN9 and PN15 seed value	<input type="checkbox"/>		<input type="checkbox"/>	
Preamble type: long DSSS, short DSSS, OFDM	<input type="checkbox"/>		<input type="checkbox"/>	
Multi-carrier support (up to 3)	<input type="checkbox"/>		<input type="checkbox"/>	
Baseband I/Q impairments	<input type="checkbox"/>		<input type="checkbox"/>	
OFDM subcarrier mask	<input type="checkbox"/>		<input type="checkbox"/>	
Windowing and filtering for spectrum control	<input type="checkbox"/>		<input type="checkbox"/>	
Multipath, up to 20 paths	<input type="checkbox"/>		<input type="checkbox"/>	
Multi-frame control	<input type="checkbox"/>		<input type="checkbox"/>	
Channel encoder				
Scrambler ON/OFF			<input type="checkbox"/>	
Convolutional encoder ON/OFF			<input type="checkbox"/>	
OFDM scrambler and reserved service bits			<input type="checkbox"/>	
PBCC encoder ON/OFF			<input type="checkbox"/>	
DSSS scrambler			<input type="checkbox"/>	
MAC parameter configuration				
Header			<input type="checkbox"/>	
FCS			<input type="checkbox"/>	
Sequence number			<input type="checkbox"/>	
802.11n				
20 or 40 MHz bandwidth	<input type="checkbox"/>		<input type="checkbox"/>	
MCS index from 0 to 32	<input type="checkbox"/>		<input type="checkbox"/>	
MCS index from 33 to 76	<input type="checkbox"/>		<input type="checkbox"/>	
Data source types: all 0s, PN9, PN15, user-defined file	<input type="checkbox"/>		<input type="checkbox"/>	
PN9 and PN15 seed value	<input type="checkbox"/>		<input type="checkbox"/>	
Operating mode: legacy, mixed, green field	<input type="checkbox"/>		<input type="checkbox"/>	
Beacon frame			<input type="checkbox"/>	
Windowing and filtering for spectrum control	<input type="checkbox"/>		<input type="checkbox"/>	
MIMO configurations for up to 4 transmitter signals	<input type="checkbox"/>		<input type="checkbox"/>	
Direct mapping or spatial expansion	<input type="checkbox"/>		<input type="checkbox"/>	
Space-time block coding	<input type="checkbox"/>		<input type="checkbox"/>	
MIMO channel models A through F or user-defined	<input type="checkbox"/>		<input type="checkbox"/>	
Channel encoder				
Scrambler ON/OFF			<input type="checkbox"/>	
Channel coding ON/OFF			<input type="checkbox"/>	
BCC encoding			<input type="checkbox"/>	
LDPC encoding			<input type="checkbox"/>	
Interleaver On/Off			<input type="checkbox"/>	
MAC parameter configuration				
Header (general, RTS, CTS)			<input type="checkbox"/>	
FCS			<input type="checkbox"/>	
Sequence number			<input type="checkbox"/>	
Aggregation MPDU			<input type="checkbox"/>	
Minimum MPDU start spacing			<input type="checkbox"/>	
Frequency selective I/Q impairment (VHT-PPDU)	<input type="checkbox"/>		<input type="checkbox"/>	

802.11 WLAN	Component & transmitter testing	Receiver testing
	Basic waveform playback mode	Advanced waveform playback mode
802.11ac		
20, 40, 80, 80+80, or 160 MHz bandwidth	<input type="checkbox"/>	<input type="checkbox"/>
Non-HT and VHT NDP format generation	<input type="checkbox"/>	<input type="checkbox"/>
Beacon frame		<input type="checkbox"/>
MCS index from 0 to 9	<input type="checkbox"/>	<input type="checkbox"/>
1024QAM	<input type="checkbox"/>	<input type="checkbox"/>
Data source types: all 0s, PN9, PN15, user-defined file	<input type="checkbox"/>	<input type="checkbox"/>
PN9 and PN15 seed value	<input type="checkbox"/>	<input type="checkbox"/>
Windowing and filtering for spectrum control	<input type="checkbox"/>	<input type="checkbox"/>
Downclocking ratio	<input type="checkbox"/>	<input type="checkbox"/>
MIMO configurations for up to 8 transmitter signals	<input type="checkbox"/>	<input type="checkbox"/>
Direct mapping or spatial expansion	<input type="checkbox"/>	<input type="checkbox"/>
Space-time block coding	<input type="checkbox"/>	<input type="checkbox"/>
Beamforming	<input type="checkbox"/>	<input type="checkbox"/>
802.11ac MIMO channel models A through F or user-defined	<input type="checkbox"/>	<input type="checkbox"/>
Channel encoder ON/OFF		<input type="checkbox"/>
Scrambler ON/OFF		<input type="checkbox"/>
BCC or LDPC channel coding		<input type="checkbox"/>
Interleaver On/Off		<input type="checkbox"/>
MAC parameter configuration		
Header (general, RTS, CTS)		<input type="checkbox"/>
FCS		<input type="checkbox"/>
Sequence number		<input type="checkbox"/>
Aggregation MPDU		<input type="checkbox"/>
Minimum MPDU start spacing		<input type="checkbox"/>
Single or multi-user MIMO (up to 8 streams)		<input type="checkbox"/>
Frequency selective I/Q impairment (VHT-PPDU)	<input type="checkbox"/>	<input type="checkbox"/>

802.11 WLAN	Component & transmitter testing	Receiver testing
	Basic waveform playback mode	Advanced waveform playback mode
802.11ah		
1, 2, 4, 8, 16 MHz bandwidth	<input type="checkbox"/>	<input type="checkbox"/>
PPDU Format, NDP for sounding or NDP MAC	<input type="checkbox"/>	<input type="checkbox"/>
Format of S1G, 1 MHz duplicate, 2 MHz duplicate	<input type="checkbox"/>	<input type="checkbox"/>
Preamble of S1G Short and S1G Long	<input type="checkbox"/>	<input type="checkbox"/>
MCS0-10	<input type="checkbox"/>	<input type="checkbox"/>
Data Source types: all 0s, PN9, PN15, user-defined file	<input type="checkbox"/>	<input type="checkbox"/>
Windowing and filtering for spectrum control	<input type="checkbox"/>	<input type="checkbox"/>
Oversampling ratio	<input type="checkbox"/>	<input type="checkbox"/>
MIMO configuration for up to 4 transmitter signals	<input type="checkbox"/>	<input type="checkbox"/>
Direct mapping or spatial expansion	<input type="checkbox"/>	<input type="checkbox"/>
Space-time block coding	<input type="checkbox"/>	<input type="checkbox"/>
Beamforming	<input type="checkbox"/>	<input type="checkbox"/>
Channel encoder ON/OFF		<input type="checkbox"/>
Scrambler ON/OFF		<input type="checkbox"/>
BCC or LDPC channel coding		<input type="checkbox"/>
Interleaver ON/OFF		<input type="checkbox"/>
MAC parameter configuration		
Header (general, RTS, CTS, or short frame)		<input type="checkbox"/>
MAC FCS		<input type="checkbox"/>
Sequencer number		<input type="checkbox"/>
Aggregated MPDU		<input type="checkbox"/>
Minimum MPDU start spacing		<input type="checkbox"/>
Frequency selective I/Q impairment	<input type="checkbox"/>	<input type="checkbox"/>

802.11 WLAN	Component & transmitter testing		Receiver testing	
	Basic waveform playback mode		Advanced waveform playback mode	
802.11ax				
20, 40, 80, 80+80, or 160 MHz bandwidth	<input type="checkbox"/>		<input type="checkbox"/>	
OFDMA Resource Units configuration	<input type="checkbox"/>		<input type="checkbox"/>	
Dual-Carrier Modulation	<input type="checkbox"/>		<input type="checkbox"/>	
Non-HT, HE NDP, HE SU/Extended Range SU/MU PPDU formats generation	<input type="checkbox"/>		<input type="checkbox"/>	
HE trigger based PPDU generation			<input type="checkbox"/>	
HE Extended-Range SU PPDU with single 106-tone RU			<input type="checkbox"/>	
LTF Symbol Interval Mode	<input type="checkbox"/>		<input type="checkbox"/>	
MCS index from 0 to 11	<input type="checkbox"/>		<input type="checkbox"/>	
1024QAM	<input type="checkbox"/>		<input type="checkbox"/>	
Data source types: all Os, PN9, PN15, user-defined file	<input type="checkbox"/>		<input type="checkbox"/>	
PN9 and PN15 seed value	<input type="checkbox"/>		<input type="checkbox"/>	
Windowing and filtering for spectrum control	<input type="checkbox"/>		<input type="checkbox"/>	
MIMO configurations for up to 8 transmitter signals	<input type="checkbox"/>		<input type="checkbox"/>	
Spatial Mapping Matrix	<input type="checkbox"/>		<input type="checkbox"/>	
Space-time block coding	<input type="checkbox"/>		<input type="checkbox"/>	
Channel encoder ON/OFF			<input type="checkbox"/>	
Scrambler ON/OFF			<input type="checkbox"/>	
BCC or LDPC channel coding			<input type="checkbox"/>	
BCC Interleaver On/Off			<input type="checkbox"/>	
Trigger frame			<input type="checkbox"/>	
MAC parameter configuration				
Header (general, RTS, CTS, or short frame)			<input type="checkbox"/>	
FCS			<input type="checkbox"/>	
Sequencer number			<input type="checkbox"/>	
Aggregated MPDU			<input type="checkbox"/>	
Minimum MPDU start spacing			<input type="checkbox"/>	
Single or multi-user MIMO (up to 8 streams)			<input type="checkbox"/>	

Supported Standards

WLAN format	Approval date	IEEE technical specification
802.11a	1999	
802.11b	1999	802.11-2007
802.11g	2003	802.11-2010
802.11j	2004	802.11-2012
802.11p	2010	802.11ac/D7.0
802.11n	2009	802.11-03/940r4 ¹
802.11ac	2013	802.11-09/0308r12 ²
802.11ah	2016	802.11ah/D1.1
802.11ax	2019 (planned)	802.11ax/D1.3

1. 802.11n channel models.
2. 802.11ac channel models.

Performance Characteristics

Definitions

Typical (typ):

Represents characteristic performance, which 80% of the instruments manufactured will meet. This data is not warranted, does not include measurement uncertainty, and is valid only at room temperature (approximately 25 °C).

Characteristic:

Non-warranted value based on testing during development phase of this product.

In the following table, characteristics for the N5162A/N5182A apply to all instruments with serial number 4742xxxx or greater, and to instruments with lower serial numbers that have Option 1EA (high power output).

EVM (typical), valid power range							
Standard	Frequency	N5172B/ N5182B	N5162A/ N5182A	E4438C	E8267D	M9381A	M9420A
802.11a/g/j/p OFDM	2.412 GHz	< 0.28%, ≤ +10 dBm	< 0.28%, ≤ +10 dBm	< 1%, ≤ -1 dBm	< 0.8%, ≤ -1 dBm	< 0.27%, ≤ +6 dBm	–
	5.805 GHz	< 0.35%, ≤ +4 dBm	< 0.45%, ≤ +4 dBm	< 1%, ≤ -1 dBm	< 0.6%, ≤ +6 dBm	< 0.47%, ≤ 0 dBm	0.6%, -5 dBm
802.11b/g DSSS	2.412 GHz	< 0.34%, ≤ +10 dBm	< 0.34%, ≤ +10 dBm	< 1%, ≤ -1 dBm	< 0.7%, ≤ +8 dBm	< 0.24%, ≤ +10 dBm	4%, 0 dBm
802.11n OFDM 20 MHz BW	2.412 GHz	< 0.35%, ≤ +10 dBm	< 0.3%, ≤ +10 dBm	< 0.5%, ≤ +4 dBm	< 0.8%, ≤ -2 dBm	< 0.27%, ≤ +4 dBm	–
	5.805 GHz	< 0.5%, ≤ +6 dBm	< 0.4%, ≤ +6 dBm	< 0.5%, ≤ 0 dBm	< 0.5%, ≤ +6 dBm	< 0.49%, ≤ 0 dBm	0.7%, -5 dBm
802.11n OFDM 40 MHz BW	2.422 GHz	< 0.35%, ≤ +10 dBm	< 0.35%, ≤ +10 dBm	< 0.5%, ≤ +4 dBm	< 0.8%, ≤ -2 dBm	< 0.24%, ≤ +4 dBm	–
	5.795 GHz	< 0.4%, ≤ +6 dBm	< 0.4%, ≤ +6 dBm	< 0.5%, ≤ 0 dBm	< 0.5%, ≤ +6 dBm	< 0.49%, ≤ 0 dBm	0.6%, -5 dBm
802.11ac OFDM 40 MHz BW	5.795 GHz	< 0.5%, ≤ +4 dBm	< 0.5%, ≤ +4 dBm	< 0.5%, ≤ 0 dBm	< 0.5%, ≤ +6 dBm	< 0.45%, ≤ 0 dBm	–
802.11ac OFDM 80 MHz BW	5.775 GHz	< 0.5%, ≤ +4 dBm	< 0.5%, ≤ +4 dBm	< 1%, ≤ 0 dBm	< 0.6%, ≤ +6 dBm	< 0.49%, ≤ 0 dBm	–
802.11ac OFDM 160 MHz BW	5.25 GHz	< 0.5%, ≤ +4 dBm	Not supported	Not supported	Not supported	< 0.64%, ≤ +2 dBm	–
802.11ah 1 MHz BW	850 MHz	< 0.34%, ≤ +10 dBm	< 0.40%, ≤ +10 dBm	< 0.60%, ≤ +10 dBm	< 0.72%, ≤ +10 dBm	–	–
802.11ah 2 MHz BW	920 MHz	< 0.20%, ≤ +10 dBm	< 0.28%, ≤ +10 dBm	< 0.36%, ≤ +10 dBm	< 0.40%, ≤ +10 dBm	–	–
802.11ax OFDM 80 MHz BW	5.775 GHz	< 0.5%, ≤ +5 dBm	–	–	–	–	–
802.11ax OFDM 160 MHz BW	5.25 GHz	< 0.5%, ≤ +5 dBm	–	–	–	–	–

All EVM measurements were made with an N9030A PXA signal analyzer with Option B1X (160 MHz bandwidth), using the 89601B vector signal analyzer software with Options B7R, B7Z, B7J, B7H and B7X for 802.11a/b/g/j/p, 802.11n, 802.11ac, 802.11ah, and 802.11ax modulation analysis.

	802.11a/g/ j/p OFDM	802.11b/g DSSS	802.11n OFDM 20 MHz BW	802.11n OFDM 40 MHz BW	802.11ac OFDM 80 MHz BW	802.11ah 2 MHz BW	802.11ax OFDM 80 MHz BW	802.11ax OFDM 160 MHz BW
Software settings								
Data rate	54 Mbps	11 Mbps	–	–	–	–	–	–
MCS index	–	–	15	15	6	8	11	11
Modulation	64QAM	–	64QAM	64QAM	64QAM	256QAM	1024QAM	1024QAM
Coding rate	3/ 4	–	5/6	5/6	3/ 4	3/ 4	5/6	5/6
Encoder	On	CCK	On	On	On (BCC)	On (BCC)	–	–
Scrambler	On	DSSS On	On	On	On	On	On	On
Interleaver	On	On	On	On	On	On	–	–
Scrambler initialization	93	–	93	93	93	93	93	93
Support carrier setup	all channels active	–	–	–	–	–	–	–
Idle interval	100 μ s	100 μ s	20 μ s	20 μ s	20 μ s	20 μ s	20 us	20 us
Oversampling ratio	≥ 2	≥ 2	≥ 2	2	1.25	2	2	1.25
Data type	PN15	PN15	PN15	PN15	PN15	PN15	PN15	PN15
Data length	1024	1024	1024	1024	1024	1024	16384	16384
Window length	≥ 8	–	≥ 16	≥ 16	2	2	2	4
Spectrum control filter type	–	Gaussian	–	–	Root raised cosine	–	Root raised cosine	Root raised cosine
Length (symbols)	–	6	–	–	100	–	17	9
Filter parameter	–	BT = 0.7	–	–	Alpha = 0.05	–	Alpha = 0.05	Alpha = 0.05
Bandwidth	–	–	20 MHz	40 MHz	80 MHz	2 MHz	80 MHz	160 MHz
Aggregation MPDU	–	–	Off	Off	On	On	On	On
Signal generation settings								
Reconstruction filter	Thru	Thru	Thru	Thru	Thru	Thru	Thru	Thru
ALC	On	On	On	On	On	On	On	On
RF blanking	Off	Off	Off	Off	Off	Off	Off	Off
Modulation attenuation	8 to 10 dBm	8 to 10 dBm	Auto	Auto	Auto	Auto	Auto	Auto
Waveform runtime scaling	70%	70%	70%	70%	70%	70%	70%	70%
89601B settings								
Range			Optimal	Optimal	Optimal	Optimal	Optimal	Optimal
Equalizer training			Preamble, pilots & data	Preamble, pilots & data	Preamble, pilots & data	Preamble & data	Preamble, pilots & data	Preamble, pilots & data

Ordering Information

Software licensing and configuration

Signal Studio offers flexible licensing options, including:

- **Fixed license:** Allows you to create unlimited I/Q waveforms with a specific Signal Studio product and use them with a single, specific platform.
- **Transportable/floating license:** Allows you to create unlimited I/Q waveforms with a specific Signal Studio product and use them with a single platform (or PC in some cases) at a time. You may transfer the license from one product to another.
- **Waveform license:** Allows you to generate up to 545 user-configured I/Q waveforms with any Signal Studio product and use them with a single, specific platform.

The table below lists fixed, perpetual licenses only; additional license types may be available. For detailed licensing information and configuration assistance, please refer to the Licensing Options web page at www.keysight.com/find/SignalStudio_licensing.

N7617B Signal Studio for WLAN 802.11a/b/g/j/p/n/ac/ah/ax

Model-Option	Description
Connectivity	
N7617B-1FP	Connect to E4438C ESG
N7617B-2FP	Connect to E8267D PSG
N7617B-3FP	Connect to N5182/62 MXG, N5172 EXG
N7617B-6FP	Connect to N5106A PXB
N7617B-7FP	Connect to Keysight simulation software
N7617B-9FP	Connect to M9381A
N7617B-AFP	Connect to M8190A arbitrary waveform generator
Capability	
N7617B-FFP	Basic 802.11a/b/g/j/p/n
N7617B-GFP	Basic 802.11ac WLAN
N7617B-JFP	Basic 802.11ah
N7617B-RFP	Advanced 802.11a/b/g/j/p/n
N7617B-TFP	Advanced 802.11ac WLAN
N7617B-UFP	Advanced 802.11ah
N7617B-VFP	Advanced 802.11ax

Try Before You Buy!

Free 30-day trials of Signal Studio software provide unrestricted use of the features and functions, including signal generation, with your compatible platform. Redeem a trial license online at

www.keysight.com/find/SignalStudio_trial

Hardware configurations

To learn more about compatible hardware and required configurations, please visit: www.keysight.com/find/SignalStudio_platforms

PC requirements

A PC is required to run Signal Studio. www.keysight.com/find/SignalStudio_pc

Additional Information

Websites

Signal Studio

Signal Studio and Signal Creation Software:
www.keysight.com/find/SignalStudio

Signal Studio for WLAN:
www.keysight.com/find/n7617b or www.keysight.com/find/ss-wlan

Signal Studio for DFS Radar Profiles:
www.keysight.com/find/n7607b

Access the comprehensive online documentation, which includes the complete software HELP, download the software, and request a trial license.

Keysight's WLAN design and test solutions

www.keysight.com/find/wlan

Literature

Eye on 802.11ax: What it is and How to Overcome the Test Challenges it Creates, White Paper, 5992-1581EN

Testing New-generation Wireless LAN, Application Note, 5990-8856EN

Creating and Optimizing 802.11ac Signals and Measurements, Application Note, 5991-0574EN

Testing Very High Throughput 802.11ac Signals, Application Note, 5990-9987EN

Signal Studio Software, Brochure, 5989-6448EN

Learn more at: www.keysight.com

For more information on Keysight Technologies' products, applications or services, please contact your local Keysight office. The complete list is available at:
www.keysight.com/find/contactus

