

# Keysight Technologies

## Scalar Network Analyzer

### Migrating from Scalar to Vector Network Analyzer Systems

Selection Guide

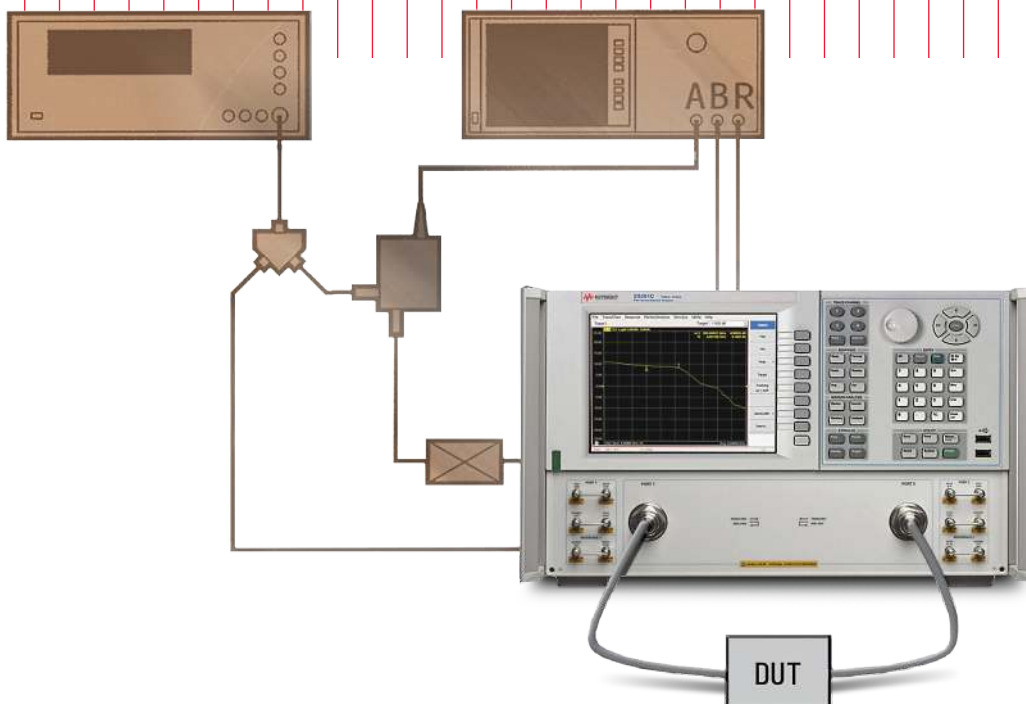

## A New Standard for Low-cost Basic RF Network Analysis

In the fast paced world of RF manufacturing test, it is important to stay current and competitive.

The popularity of scalar analyzers for network analysis measurements has declined greatly over the past ten years, as the usage of low-cost, accurate, and easy-to-use vector network analyzers (VNAs) has dramatically increased. With the advent of lower-cost VNAs, the economic benefits of a scalar solution have diminished. The majority of scalar network analyzer users have already begun migrating to high-performance, low-cost network analyzers such as Keysight Technologies, Inc's ENA, ENA-L, and PNA-L network analyzers. Now is the time to consider a test migration path.

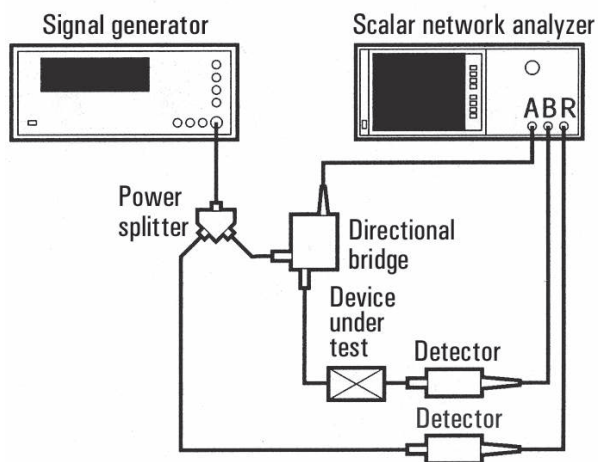

Figure 1. Typical scalar network analyzer measurement system.

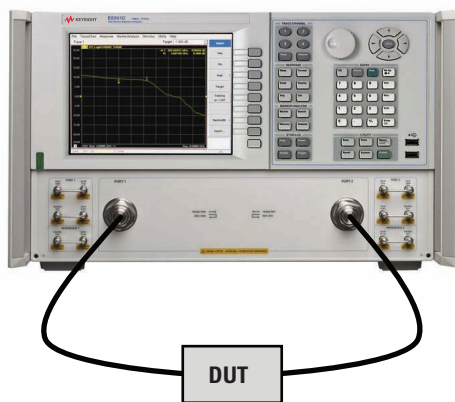

Figure 2. Typical VNA measurement system.

## A New Standard for Low-cost Basic RF Network Analysis (continued)

### Historical advantages of scalar analyzers

Scalar analyzers have been very popular for making basic RF and microwave measurements for many years. Scalar analyzers combine a simple measurement configuration with basic scalar measurements to provide fast, economical scalar measurements on a variety of RF and microwave devices. Scalar analyzers have been used to measure gain and gain flatness of amplifiers, filter responses, return loss, and mixer conversion loss. For these basic measurements a scalar analyzer has been a simple, basic, and cost-effective measurement solution.

### Today's advantages of vector network analyzers – more measurements and better accuracy

The demand for new types of measurements and improved test performance has accelerated the need for higher performance measurements, which has driven the advancement of VNAs, both in capabilities as well as driving the price point of vector analyzers down. Today, VNAs provide significantly greater measurement capabilities and accuracies than are available from scalar measurement solutions.

VNAs measure amplitude and phase response, which allows vector error correction techniques to be used for calibration, removing systematic measurement errors, and providing greater measurement accuracy. Phase measurements also provide additional information about the devices, characterizing the complex impedance of the device as well as the group delay response. The ability to measure phase allows for more complete characterization of devices, as well as more accurate measurements. Additionally, VNAs utilize a tuned receiver approach, as opposed to a broadband detector used by scalar analyzers, and this provides greater dynamic range, and eliminates false measurement responses due to extraneous signals such as source harmonics. VNAs also utilize modern data archiving techniques, making it very easy to store, retrieve, and print a data trace using the modern Windows capabilities of vector network analyzers.

While VNAs have many advanced measurement capabilities, they also have the ability to make basic measurements similar to a scalar analyzer. A VNA can perform a trace normalization or simple response calibration, without using a calibration kit, providing measurement capabilities similar to a scalar analyzer. Unlike scalar network analyzers a VNA system offers greater than 100 dB of dynamic range.

Clearly the advantages of the vector network analyzer have driven the migration from scalar analyzer systems to vector systems.

## A New Standard for Low-cost Basic RF Network Analysis (continued)

### Take a look at a price comparison

Did you know you can buy a 50 GHz VNA for about the same price as a 50 GHz scalar analyzer system?

In the past, one of the basic advantages of scalar analyzers was their ability to make basic microwave measurements with a lower initial capital investment in the measurement system. With the evolution and advancements in vector analyzers, the price advantage of scalar analyzers has diminished. The table below illustrates the comparative prices between a VNA system and a scalar analyzer system by frequency ranges. For RF frequencies below 3 GHz, a VNA costs only 40-50% of a comparable scalar analyzer system. The cost of a vector and scalar system are approximately equivalent for a 6 GHz measurement system. A 20 GHz vector measurement system is 1.5 times the cost of a scalar system, while a 40 GHz system is approximately 1.3 times the cost, and a 50 GHz vector system is only 1.1 times the cost of a scalar system. For millimeter-wave frequencies above 67 GHz in waveguide bands, scalar measurement systems still have a price advantage.

Table 1. Price comparison ratio by frequency range – VNA price relative to scalar analyzer system price

Price comparison	1 GHz	3 GHz	6 GHz	20 GHz	40 GHz	50 GHz
Vector network analyzer price	0.4\$	0.5\$	\$	1.5\$	1.3\$	1.1\$
Scalar network analyzer price	\$	\$	\$	\$	\$	\$

# A Variety of Frequency Ranges and Measurement Capabilities

Select the vector network analyzer that meets your measurement requirements:  
[www.keysight.com/find/na](http://www.keysight.com/find/na)

Table 2. VNA frequency selection table

9 kHz	100 kHz	300 kHz	10 MHz	1.5 GHz	3 GHz	4.5 GHz	6 GHz	8.5 GHz	13.5 GHz	20 GHz	40 GHz	50 GHz	60 GHz	110 GHz
-------	---------	---------	--------	---------	-------	---------	-------	---------	----------	--------	--------	--------	--------	---------

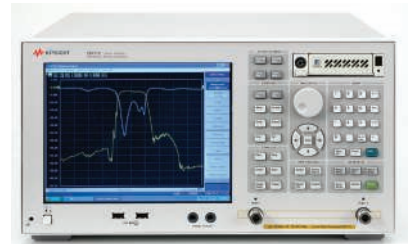
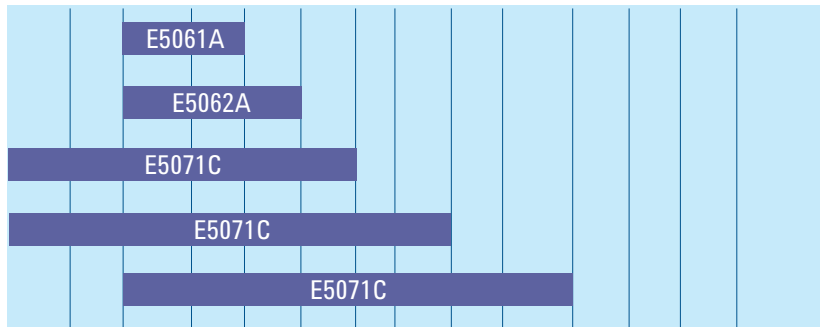

ENA network analyzers

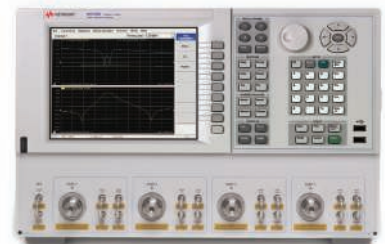
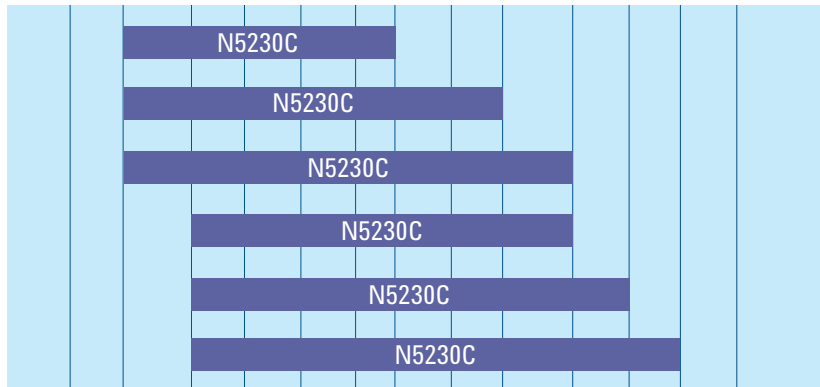

PNA-L network analyzers

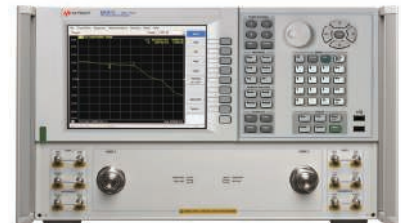
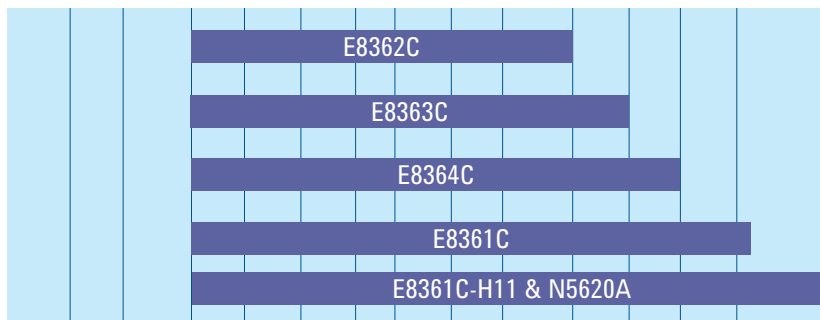

PNA network analyzers

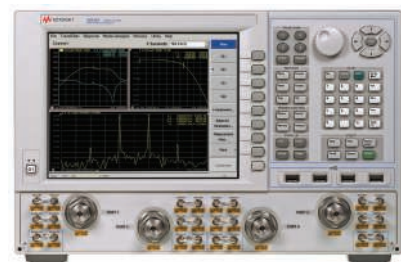
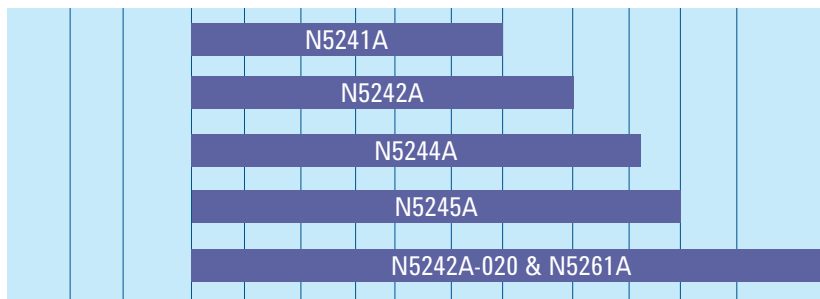

PNA-X network analyzers

## Application Comparison

Scalar analyzers have been used for many years to make basic network analyzer measurements on a variety of RF and microwave components. Shown here are some of the more common devices measured by scalar analyzers, and the equivalent configurations, features, and capabilities available from various recommended replacement VNAs.

### Amplifier measurements

Scalar analyzers have been used for many years to make basic measurements on amplifiers. Common measurements performed with scalar analyzers are gain, gain flatness, gain compression, return loss and/or VSWR, reverse isolation, and absolute power measurements. The calibration of a scalar analyzer system utilizes a short, open, and thru connection. The averaging of the short and open response provides normalization for the reflection frequency response. The thru characterizes the transmission frequency response of the measurement system. Systematic errors due to directivity, source and load match are present in both the calibration and measurement of the amplifier, and are not removed by the open, short, and load calibration of the scalar analyzer, and thus contribute to measurement uncertainty when measured with a scalar analyzer.

VNAs have become quite popular for measuring amplifiers for many reasons. Vector analyzers have built-in RF sources, signal separation devices, and detectors, which greatly simplify the measurement configuration and the measurements. Vector analyzers can measure magnitude and phase responses, allowing systematic errors of source match, load match, and directivity to be completely characterized and mathematically removed from the measurement, greatly reducing the measurement uncertainty, and improving the measurement accuracy. Additionally, the ability to measure the phase response of an amplifier allows the VNA to measure S-parameters to characterize the complex impedance of the amplifier, and measure group delay and deviation from linear phase contributed by the amplifier. For all these reasons, VNAs have become the preferred instrumentation system for complete and accurate characterization of amplifiers.

## Application Comparison (continued)

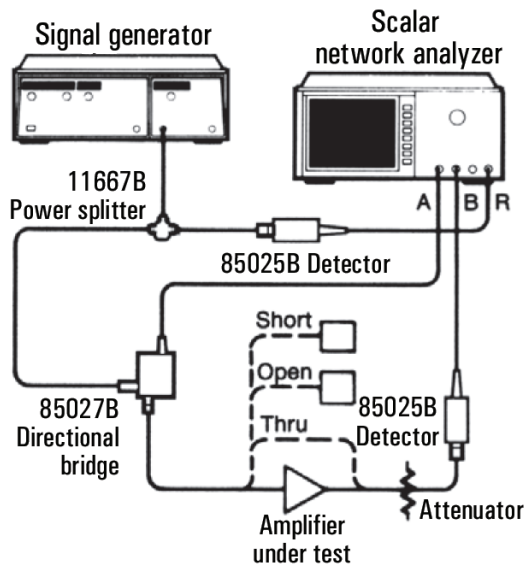

Figure 3. Scalar network analyzer test setup for simultaneous measurement of amplifier gain and input return loss.

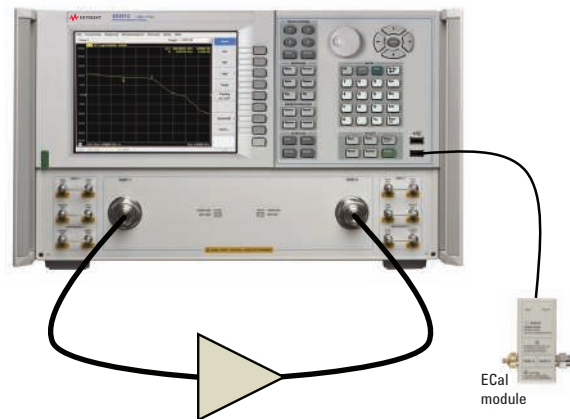

Figure 4. VNA test setup for simultaneous measurement of amplifier gain, and input return loss.

## Application Comparison (continued)

### Amplifier measurements

Shown here are some of the more common measurements made on amplifiers. Scalar analyzers perform all the basic amplifier measurements, while VNAs perform the basic measurements made by scalar analyzers, as well as additional measurements that cannot be measured by scalar analyzers. Complete characterization of an amplifier's performance requires a VNA.

Table 3. Keysight VNA amplifier measurement capabilities

### Keysight network analyzer

Measurement type	Scalar 8757	ENA-L	ENA	PNA-L	PNA	PNA-X	mm-wave PNA
<b>Basic measurements</b>							
Gain, gain compression, flatness	✓	✓	✓	✓	✓	✓	✓
Return loss and VSWR	✓	✓	✓	✓	✓	✓	✓
S-parameters (complex impedance)		✓	✓	✓	✓	✓	✓
Reverse isolation	✓	✓	✓	✓	✓	✓	✓
Group delay and phase		✓	✓	✓	✓	✓	✓
AM-PM conversion	✓	✓	✓	✓	✓	✓	
Automated gain compression						✓	
<b>High-power measurements</b>							
Absolute power measurements	✓		✓	✓	✓	✓	✓
High-power measurements	✓		✓	✓	✓	✓	
Source attenuator		✓	✓	✓	✓	✓	✓
Receiver attenuator					✓	✓	✓
Connection loop before reference path						✓	
Configurable test set			✓	✓	✓	✓	✓
<b>Harmonic measurements</b>							
Harmonics (with frequency offset mode)						✓	
Frequency offset mode			✓	✓	✓	✓	✓
Low source harmonics						✓	
Receiver attenuator					✓	✓	✓
<b>Inter-modulation distortion (IMD) measurements</b>							
Frequency offset mode			✓	✓	✓	✓	✓
Second internal source				✓		✓	
Internal combining network						✓	
Simplified swept-IMD setup						✓	
<b>Additional measurement capabilities</b>							
Noise figure						✓	
Hot-S22						✓	
DC inputs for power added efficiency			✓		✓	✓	
Internal bias tee			✓		✓	✓	✓



## Mixers and Frequency Translating Devices

A scalar network analyzer system can measure the conversion loss of a mixer. Using a VNA will provide higher accuracy conversion loss measurements, since mismatch errors can be characterized and removed during both the calibration and measurement, by combining a power meter and 2-port calibration. Additionally, a VNA can also be used to perform vector mixer measurements, providing accurate measurements of phase and absolute group delay, in addition to the conversion loss.

### Mixer measurements with a scalar analyzer

The configuration shown in Figure 5 is commonly used to measure the conversion loss of a mixer, and as shown in this configuration, can also simultaneously measure the input match of the mixer. Since the diode detectors of the scalar analyzer can detect a very wide band of frequencies, the output IF frequency, which is different from the input frequency to the mixer, can be detected and measured. Thus magnitude-only measurements of conversion loss, absolute output power, return loss, and isolation can be made, as well as nonlinear magnitude measurements such as gain compression.

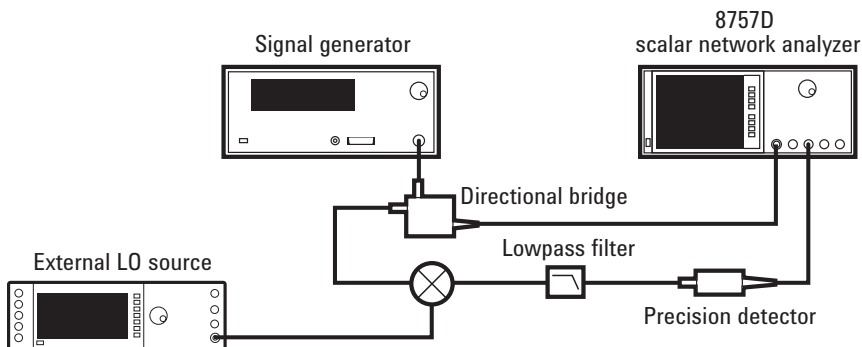

Figure 5. Scalar network analyzer configuration for measuring conversion loss and input match of a mixer.

## Mixers and Frequency Translating Devices (continued)

### Scalar mixer measurements with a vector network analyzer

A VNA can be used to perform scalar mixer measurements. A useful feature of using a vector network analyzer is the ability of a vector analyzer to completely characterize systematic errors such as directivity, source match, and load match of the measurement system, and mathematically remove these systematic errors from the measurement. The Keysight patented scalar mixer calibration technique combines a 2-port vector calibration with a power-meter calibration. Thus mismatch errors that are present during both the calibration and measurement phase are effectively removed from the measurement, providing the highest accuracy scalar conversion-loss and match measurements with a configuration that is simple to set up, calibrate, and measure. The scalar mixer calibration technique can be applied to mixers that utilize an external LO source, or also to mixers with an embedded internal LO source.

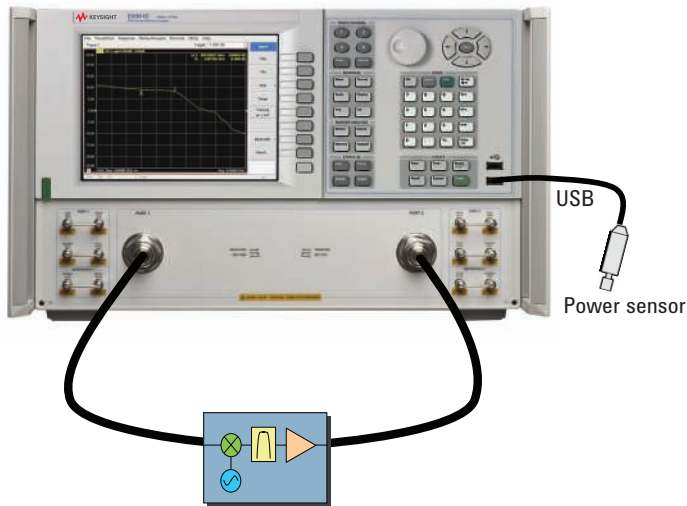

Figure 6. A very accurate scalar mixer measurement configuration using a vector network analyzer, which provides enhanced accuracy by combining a 2-port vector calibration with an external power meter calibration.

## Mixers and Frequency Translating Devices (continued)

### Vector mixer measurements with a vector network analyzer

A VNA can be used to perform very accurate measurements of phase and absolute group delay for a mixer. Using Keysight's patented vector mixer calibration (VMC) technique, a characterized reference mixer is used as a calibration standard, along with the usual open, short, and load standards. VMC removes magnitude and phase errors for both transmission and reflection measurements. This technique requires an external reference mixer that is used as a phase reference, but is not needed for phase-locking the source and receivers with an offset, as offset sweeps are achieved with the VNA's internal hardware. The VMC techniques can be applied to mixers that utilize an external LO source, or also to mixers with an embedded internal LO source.

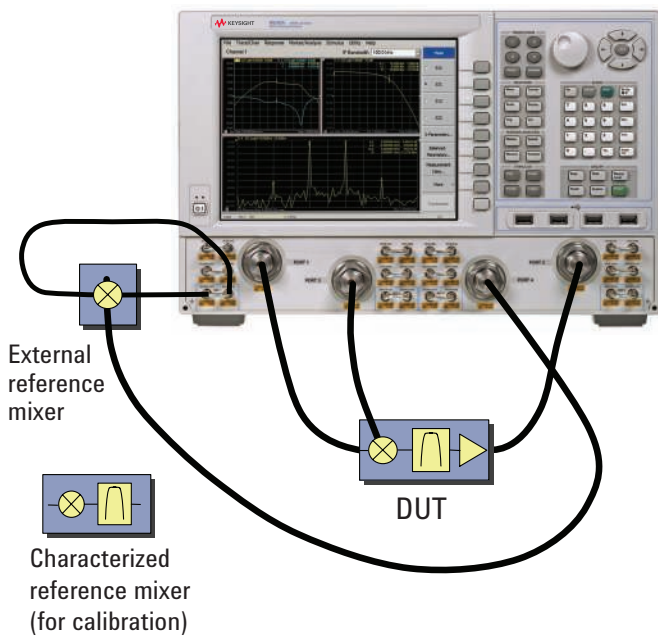

Figure 7. Vector mixer measurement configuration. Provides measurements of conversion loss, match, phase and absolute group delay for a mixer.

## Mixers and Frequency Translating Devices (continued)

### Mixer measurements

Shown here are some of the more common measurements made on mixers and frequency translation devices. Scalar analyzers perform all the basic mixer measurements, while VNA perform these basic measurements made by scalar analyzers, as well as additional measurements that cannot be measured by scalar analyzers. For the most complete characterization of a mixer or frequency translation device's performance, a VNA provides the most accurate and complete performance characterization.

Table 4. Keysight VNA mixer measurement capabilities

	8757	ENA-L	ENA	PNA-L	PNA	PNA-X	mm-wave PNA
<b>Basic measurements</b>							
Scalar conversion loss	✓	✓	✓	✓	✓	✓	✓
Return loss & VSWR	✓	✓	✓	✓	✓	✓	✓
S-parameters (complex impedance)		✓	✓	✓	✓	✓	✓
Isolation	✓	✓	✓	✓	✓	✓	✓
Match corrected conversion loss		✓	✓	✓	✓	✓	✓
Phase and group delay		✓	✓	✓	✓	✓	✓
<b>Measurement and analysis</b>							
Magnitude measurements	✓		✓	✓	✓	✓	✓
Relative phase measurement				✓	✓	✓	✓
Absolute phase measurement			✓	✓	✓	✓	✓
Compression test	✓		✓	✓	✓	✓	✓
Embedded LO measurements					✓	✓	✓
Internal dual source				✓		✓	
External source control			✓	✓	✓	✓	✓
<b>Calibration</b>							
Power meter calibration			✓	✓	✓	✓	✓
Scalar mixer calibration			✓	✓	✓	✓	
Vector mixer calibration			✓		✓	✓	✓

## Filters and Frequency Selective Devices

Scalar analyzers have been widely used to measure and tune frequency selective devices such as filters, diplexers, and duplexers. The scalar analyzer was popular for tuning these types of devices due to its ability to provide fast sweeps that allowed real-time tuning capability, as well as the ability to display transmission and input match responses simultaneously. A VNA can provide the same display capabilities, and fast sweeps required for real-time tuning of filters and frequency selective devices, plus improved measurement accuracy due to vector error correction.

VNAs have several significant advantages over scalar analyzers. Vector analyzers have typically  $-110$  dBm sensitivity, while scalar analyzers with their broadband detectors have  $-60$  dBm sensitivity. Consider a filter with a  $-100$  dB rejection band response. A scalar analyzer will measure a  $-60$  dB rejection band, while a vector analyzer will correctly measure  $-100$  dB. Thus vector analyzers provide much better characterization of rejection band responses. Vector analyzers also utilize tuned receivers, while scalar analyzers utilize broad-band detection. Scalar analyzers are thus prone to measurement errors due to source harmonics. Consider a 4 GHz band-pass filter. When the source is tuned to 2 GHz, and the filter rejection is 60 dB, but the source second harmonic at 4 GHz is  $-30$  dB, the scalar analyzer will incorrectly report the 2 GHz rejection as  $-30$  dB instead of  $-60$  dB.

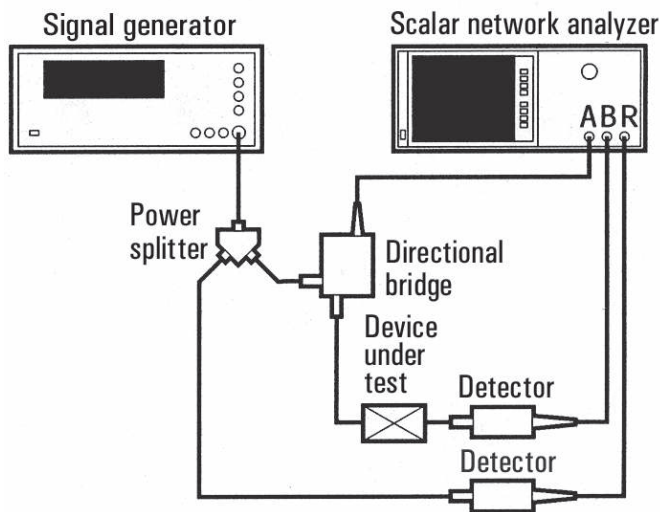

Figure 8. Typical scalar analyzer configuration for measuring a filter.

# Filters and Frequency Selective Devices (continued)

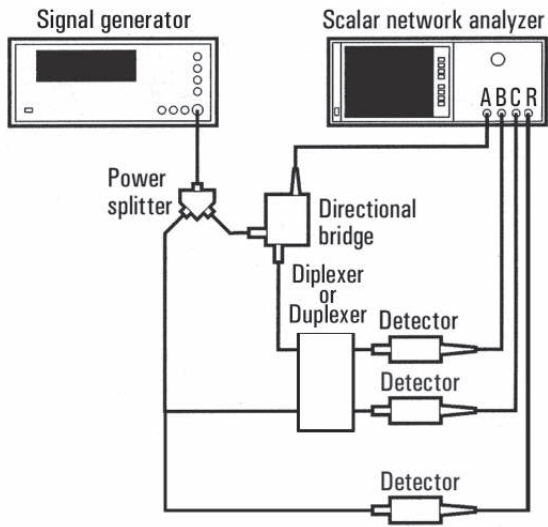

Figure 9. Typical scalar analyzer configuration for measuring a diplexer or duplexer.

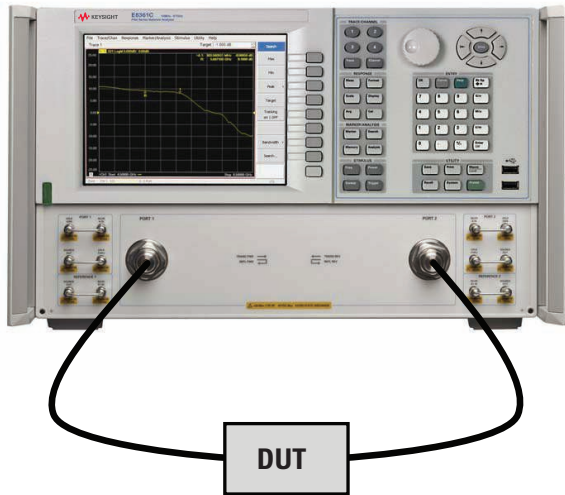

Figure 10. Vector analyzer configuration for measuring a filter.

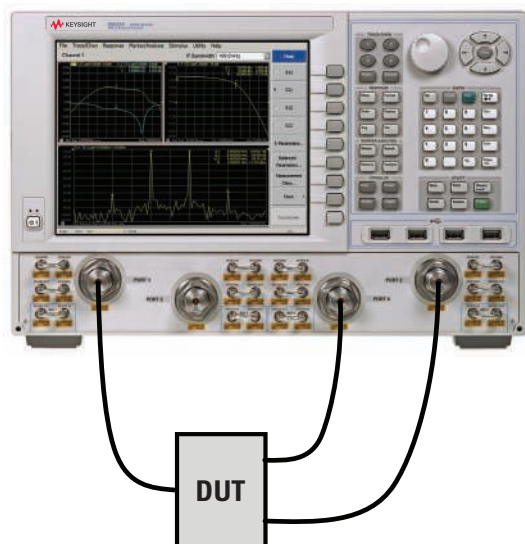

Figure 11. Vector analyzer configuration for measuring a diplexer or duplexer.

## Filters and Frequency Selective Devices (continued)

### Frequency selective devices

Shown here are some of the more common measurements made on filters and frequency selective devices. Scalar analyzers perform all the basic measurements, while VNAs perform the basic measurements as well as additional measurements that cannot be measured by scalar analyzers. For the most complete characterization of frequency selective devices, a vector network analyzer provides the most accurate and complete performance characterization.

Table 5. Keysight VNA filter and frequency selective device measurement capabilities

	8757	ENA-L	ENA	PNA-L	PNA	PNA-X	mm-wave PNA
<b>Basic measurements</b>							
Insertion loss and pass-band flatness	✓	✓	✓	✓	✓	✓	✓
Return loss & VSWR	✓	✓	✓	✓	✓	✓	✓
S-parameters (complex impedance)		✓	✓	✓	✓	✓	✓
Group delay and phase		✓	✓	✓	✓	✓	✓
<b>Dynamic range</b>							
Wide dynamic range		✓	✓	✓	✓	✓	✓
Direct receiver access to obtain widest possible dynamic range				✓	✓	✓	✓
<b>Calibration</b>							
Adapter removal calibration			✓	✓	✓	✓	✓
SOLR (unknown thru)			✓	✓	✓	✓	✓
Interpolated calibration		✓	✓	✓	✓	✓	✓
<b>Measurement and analysis</b>							
Segment sweep		✓	✓	✓	✓	✓	✓
Four-parameter display		✓	✓	✓	✓	✓	✓
Marker statistics function		✓	✓	✓	✓	✓	✓
<b>Other functions</b>							
Time domain mode & gating		✓	✓	✓	✓	✓	✓
Balanced measurement capability			✓	✓	✓	✓	
Multi-port measurement capability		✓	✓	✓	✓	✓	

## Research and Development

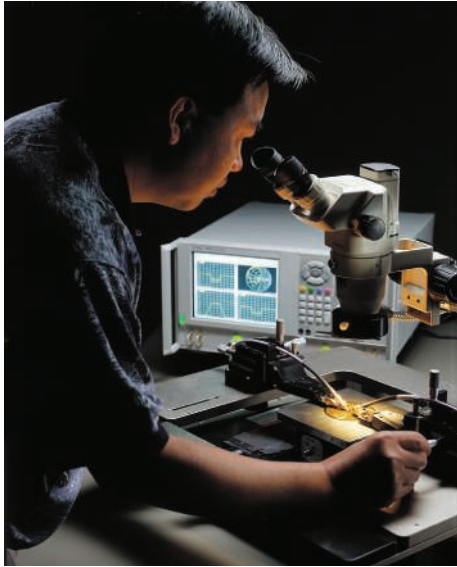

Research and development (R&D) activities require a wide range of measurement capability and flexibility from the measurement instrumentation. For any given development effort, a variety of different types of measurements generally need to be made to fully evaluate the design. R&D assets also need to be flexible to accommodate a variety of different development projects and activities. Thus R&D activities place the most stringent demands on instrumentation for both capabilities and flexibility. While scalar analyzers have been used in the past for R&D activities, with the advanced capabilities and flexibility offered by vector network analyzers, they have become the preferred measurement instrumentation for R&D applications. Shown below is a comparison of the capabilities of a scalar analyzer to a variety of VNAs. Clearly the vector analyzers provide significantly more capability and flexibility than scalar analyzers, making them the obvious choice for R&D environments.



## Research and Development (continued)

Table 6. Keysight VNA R&D measurement capabilities

	8757	ENA-L	ENA	PNA-L	PNA	PNA-X	mm-wave PNA
<b>Basic measurements</b>							
S-parameters		✓	✓	✓	✓	✓	✓
Transmission/reflection test set	✓	✓					
Absolute power	✓		✓	✓	✓	✓	✓
Spectrum analyzer function						✓	
<b>Non-coaxial devices</b>							
TRL calibration (on-wafer measurements)			✓	✓	✓	✓	✓
Waveguide measurements	✓		✓	✓	✓	✓	✓
<b>Non-insertable devices</b>							
Adapter removal calibration			✓	✓	✓	✓	✓
SOLR (unknown thru calibration)			✓	✓	✓	✓	✓
Ecal support for different connector types		✓	✓	✓	✓	✓	✓
<b>Applications</b>							
Time-domain mode/gating		✓	✓	✓	✓	✓	✓
Frequency offset mode			✓	✓	✓	✓	✓
TOI and harmonics				✓	✓	✓	✓
Noise figure measurements						✓	
Pulsed RF: Wide pulse width			✓	✓	✓	✓	✓
Pulsed RF: Narrow pulse width					✓	✓	✓
Frequency conversion application			✓		✓	✓	✓
Scalar-calibrated converter measurements			✓	✓	✓	✓	✓
Antenna			✓	✓	✓	✓	
Materials measurement		✓	✓	✓	✓	✓	✓
Automated gain compression						✓	
<b>Programming and connectivity</b>							
Windows		✓	✓	✓	✓	✓	✓
GP-IB interface	✓	✓	✓	✓	✓	✓	✓
LAN interface		✓	✓	✓	✓	✓	✓
Internal programming capability		✓	✓	✓	✓	✓	✓
Keysight's Advanced Design System linkage			✓	✓	✓	✓	✓
VEE linkage	✓			✓	✓	✓	✓
IntuiLink		✓	✓	✓	✓		✓
LXI compliance		✓	✓				
Touch screen display		✓	✓	✓	✓	✓	✓

## Manufacturing Test



VNAs are replacing scalar analyzers in manufacturing environments.

Manufacturing test is about economics and providing the best value in a product, and companies that can provide this will thrive and grow. Providing the best value involves reducing the cost of test by making it faster, simpler, and easier, while at the same time providing accurate testing to ensure a reliable, quality product. Thus the demands on the test equipment used in manufacturing test are to quickly and accurately characterize the device. Scalar analyzers have been very popular in manufacturing environments due to their low capital cost, fast sweeps that minimize measurement times, and allow real-time tuning, and their ability to display both transmission and reflection responses simultaneously.

VNAs have become very well accepted in manufacturing test environments also. They provide the same features and benefits that are needed in manufacturing test; such as low capital cost, fast sweeps, real time tuning, and the ability to display multiple measurements simultaneously. Additionally VNAs have other features and capabilities not found in scalar analyzers that provide additional benefits to manufacturing test, as shown in the accompanying comparison. Keysight has developed vector network analyzers such as the ENA, ENA-L, and PNA-L family of products that specifically address the needs of the manufacturing test environment, to help manufacturers be successful in providing the best value products.

## Manufacturing Test (continued)

Table 7. Keysight VNA manufacturing test measurement capabilities

	8757	ENA-L	ENA	PNA-L	PNA	PNA-X	mm-wave PNA
<b>Basic measurements</b>							
Fast sweeps	✓	✓	✓	✓	✓	✓	✓
Real time tuning capability	✓	✓	✓	✓	✓	✓	✓
Transmission and reflection simultaneously	✓	✓	✓	✓	✓	✓	✓
S-parameters		✓	✓	✓	✓	✓	✓
Absolute power	✓		✓	✓	✓	✓	✓
<b>Programming</b>							
Internal programming capability (I-Basic)		✓	✓				
Macro programming capability				✓	✓	✓	✓
Fast data transfer		✓	✓	✓	✓	✓	✓
<b>Calibration</b>							
Adapter-removal calibration			✓	✓	✓	✓	✓
SOLR (unknown thru)			✓	✓	✓	✓	✓
ECal support		✓	✓	✓	✓	✓	✓
<b>Measurement and analysis</b>							
Segment sweep		✓	✓	✓	✓	✓	✓
Pass/fail testing	✓	✓	✓	✓	✓	✓	✓
Embedding and de-embedding			✓	✓	✓	✓	✓
Waveform analysis command		✓	✓				
<b>Interface</b>							
GPIB	✓	✓	✓	✓	✓	✓	✓
LAN		✓	✓	✓	✓	✓	✓
I/O port		✓	✓	✓	✓	✓	✓
Parts handler interface		✓	✓	✓	✓	✓	✓
VGA output	✓	✓	✓	✓	✓	✓	✓

## Millimeter-wave Measurements

Scalar analyzers measure mm-wave devices in waveguide bands, utilizing waveguide banded source modules, and waveguide couplers and detectors. The system measures scalar values of transmission and reflection. The advantage of scalar analyzers has been their lower cost for a given waveguide band, but they can also require a lot of banded hardware to cover the full mm-wave range.

Vector mm-wave network analyzers are also available in waveguide bands, or there is a broad-band mm-wave solution that covers 10 MHz to 110 GHz in a single sweep through 1.0 mm coaxial ports. Vector mm-wave network analyzers provide both magnitude and phase measurements for both transmission and reflection, full S-parameter characterization, and do not require manually reversing the test device. MM-wave VNAs typically have a higher price point than scalar analyzer systems, but also provide much more measurement capability.

### Scalar millimeter-wave analyzer

Scalar transmission and reflection measurements

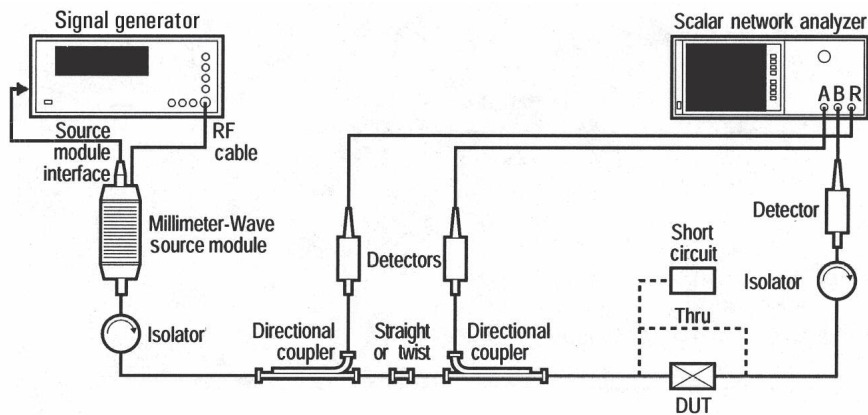

Figure 12. Typical mm-wave scalar network analyzer system utilizing banded mm-wave source modules.

## Millimeter-wave Measurements (continued)

### Vector millimeter-wave analyzers

Full S-parameter magnitude and phase measurements

Several different configurations and versions of vector mm-wave network analyzers are available. Banded vector mm-wave measurement systems provide just the frequency bands required, while broadband systems provide the ultimate in capability, flexibility, and ease of use. Traditional 2-port banded systems are available for traditional S-parameter measurements, and 4-port banded systems are available for differential measurements at millimeter frequencies. MM-wave VNAs typically have a higher price point than scalar analyzer systems, but also provide much more measurement capability.

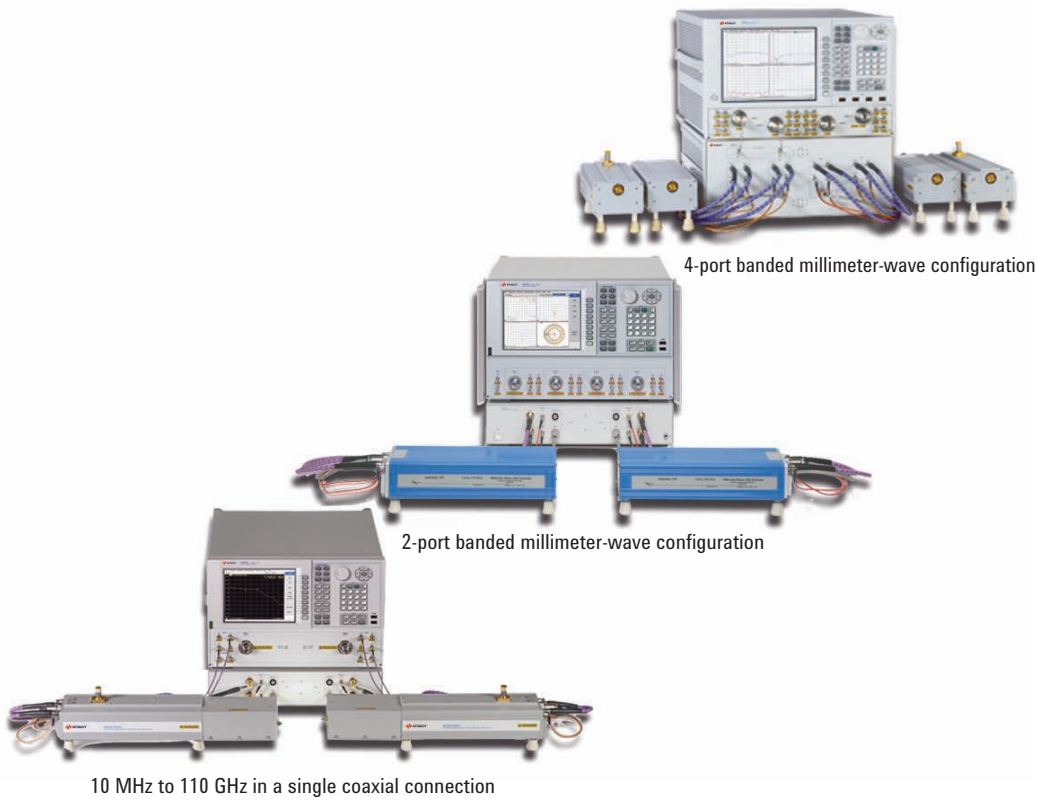

Figure 13. A wide selection of mm-wave vector network analyzers to meet your measurement needs.

## Other Unique Measurement Applications

Scalar analyzers have been in use for over 35 years, and they have found their way into many unique applications. Keysight has the measurement products and application expertise to assist you in migrating your measurements from scalar instrumentation to other equivalent measurement systems. With the evolution and progression of instrumentation, the newer system is often a better measurement solution at a lower cost.

Shown below are some unique measurement systems that have used scalar network analyzers in the past, and some new ideas, and instruments to allow making the same types of measurements. Keysight is ready to help you when you are ready to migrate from your current scalar analyzer systems.

### Remote transmission, reflection, and power measuring applications

Scalar analyzers have the ability to remote their power detectors up to 200 feet away from the scalar analyzer. Thus some scalar analyzer applications have their detectors located far from the analyzer, and sometimes in a location that is difficult to access, as illustrated below.

Scalar analyzer application

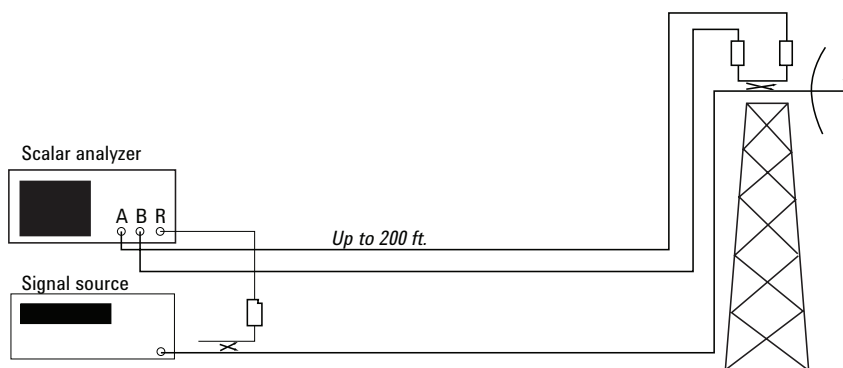

Figure 14. Typical scalar analyzer application with detectors located far from the analyzer.

# Portable RF Analyzer

## N9912A FieldFox RF analyzer

In the continuing evolution of RF and microwave measurement capabilities, Keysight has developed a portable RF analyzer. Keysight's FieldFox RF analyzer is the world's most integrated handheld for wireless installation and maintenance. Many of the unique measurement applications that used a scalar network analyzer in the past can now be measured with the FieldFox RF analyzer. In most cases, the new handheld RF analyzer will have better measurement capabilities, be more flexible, and be a significantly lower cost solution than a scalar analyzer system.



FieldFox is a small, portable instrument with powerful measurement capabilities.

### Key measurements

- Cable and antenna test (distance to fault, return loss, etc.)
- Cable loss measurements
- Insertion loss and transmission measurements
- Spectrum analyzer
- Interference analyzer
- Power meter with USB power sensor
- Vector network analysis with Smith chart display
- Vector voltmeter

### Key differentiators

- Integrated QuickCal calibrates without a calibration kit
- Immediate calibration with CalReady
- 50 percent faster than traditional handheld instruments
- Superior dynamic range (96 dB) and sensitivity (-148 dBm) in the spectrum analysis mode
- Easy-to-use, task-driven user interface

# Portable RF Analyzer (continued)

## Network analysis

The FieldFox RF analyzer has an optional network analyzer mode that provides standard vector network analyzer measurements such as  $S_{11}$ ,  $S_{11}$  phase, a Smith chart display, and  $S_{21}$  magnitude. FieldFox supports both 50 ohm and 75 ohm systems.

## Innovative calibration

FieldFox is CalReady at the RF output port, immediately following power-on or preset. This means it is already calibrated and ready to make accurate measurements such as one port cable loss, VSWR, return loss,  $S_{11}$  or  $S_{11}$  phase and distance to fault at test port.

The industry's first and only built-in calibration system that allows you to calibrate the network analyzer without carrying a calibration kit in to the field. QuickCal can automatically extend the reference plane by connecting to adapters or to the end of a jumper cable without a calibration kit.

FieldFox allows you to make broadband calibrations, which means the instrument is calibrated over the maximum frequency span. After a broadband calibration, you can change the frequency range or number of points without recalibrating the instrument.

FieldFox also supports standard mechanical calibration kits, it also allows the user to load their own calibration kit via PC software.

## Power meter

The FieldFox RF analyzer can connect with the Keysight U2000 Series USB power sensor to make RF/microwave power measurements from 9 kHz to 24 GHz. FieldFox provides true average power measurements with a wide dynamic range from -60 to +44 dBm. The sensor has an internal zeroing function, and external calibration is not needed. For remote power measurement applications, a wireless LAN can be used with the FieldFox's LAN port to provide remote measurement capabilities.

## Transmission measurements

FieldFox provides a 2-port transmission measurement that measures insertion loss, amplifier gain, filter pass-band, and loss. It also makes a  $S_{21}$  scalar measurement if Option 303 is enabled. This option covers the 2 MHz to 6 GHz frequency range.

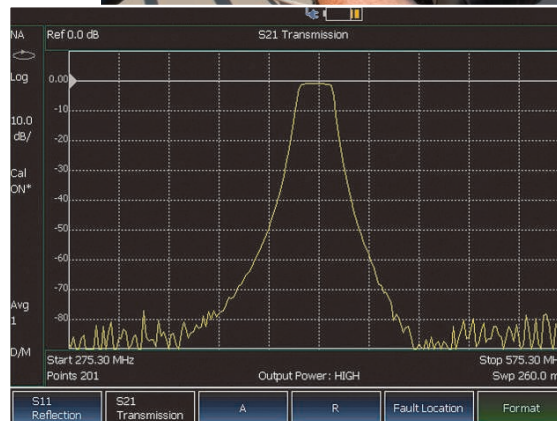



## Portable RF Analyzer (continued)

### Vector voltmeter

Using FieldFox's vector voltmeter (VVM), the phase shift and electrical length of a device can be measured. By utilizing the 'Zero' function, the phase and electrical length of one device can be measured relative to a 'golden device.' View results on the large display which can be seen as far as ten feet away. Since every FieldFox is CalReady, no calibration is needed if VVM measurements are done at the test port. FieldFox offers much of the VVM functionality of the popular Keysight 8508A, in a handheld portable form factor, and without the need for the source, bridge, and accessories required with the 8508A.

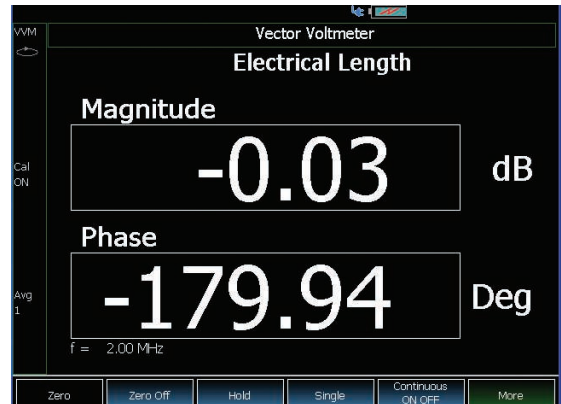

Vector voltmeter applications include: cable trimming of phase matched cables, verifying the isolation of 2-port components, radio-navigation- VHF omni-directional radio range (VOR) and instrumentation landing systems (ILS).

### Built-in spectrum analyzer

Interference can be a significant problem at remote measurement locations. FieldFox has an optional built-in spectrum analyzer that covers frequency ranges from 100 kHz to 6 GHz. It provides a fast spectrum scan to detect interference and RF burst capture to measure intermittent signals. It displays four traces at the same time, and you can choose different detector modes.

### Interference analyzer

FieldFox's interference analyzer is designed for identifying interference signals quickly in the field. FieldFox provides a spectrogram and waterfall display to detect intermittent interference signals. Signal traces can be recorded into internal memory or external flash memory devices. You can also listen to AM/FM signals to identify signal types



The spectrogram display makes it easy to detect and monitor intermittent interference signals.

### Broadband calibration

FieldFox allows you to make broadband calibrations, which means the instrument is calibrated over the maximum frequency span. After a broadband calibration, you can change the frequency range or number of points without recalibrating the instrument.

# Power Meters

Power meters provide a cost effective method of measuring power levels remotely, and with a remotely located signal separation device, can also measure transmission and reflection power levels. Typically power sensors have been able to be extended from a power meter by up to 200 feet. Advances in power sensors have also evolved to USB power sensors that do not require a power meter to measure power levels. Instead utilize software running on a PC, with the USB power sensor connecting directly to the USB connector on the PC. While USB is specified for 5 meter cable lengths, USB extenders are available that extends this distance up to 150 feet. With a USB to LAN hub, the hub can be located close to the USB sensors, and the LAN will provide virtually unlimited remote distances. One tradeoff of power sensors as compared to scalar analyzer diode detectors is power sensors have significantly slower measurement response times. The U2000 Series USB power sensors can measure up to 1000 readings per second, which is fast for a power sensor, but somewhat slower when compared to approximately 4000 data point readings per second for scalar analyzer detectors.

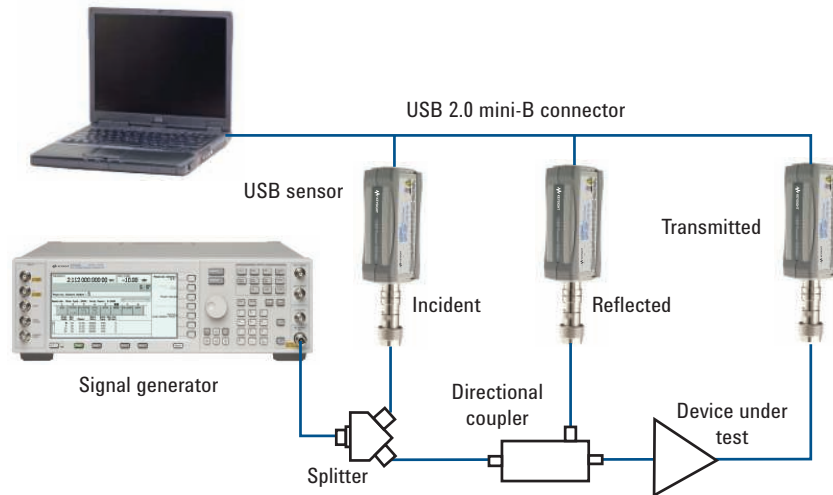

Figure 15. Configuration for using power sensors for scalar measurements on a device under test.

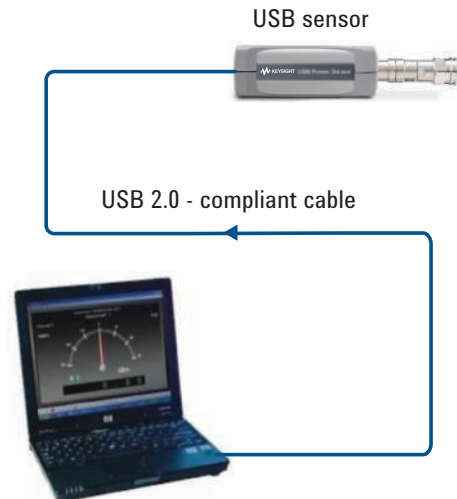

Figure 16. Remote power sensing utilizing USB power sensors with a PC and software.

## Power Meters (continued)

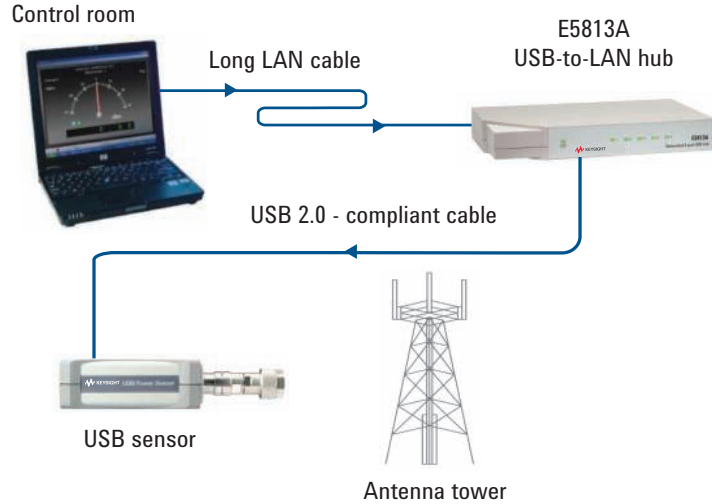

Figure 17. Remote power sensing over very long distances utilizing USB power sensors and a USB to LAN hub.

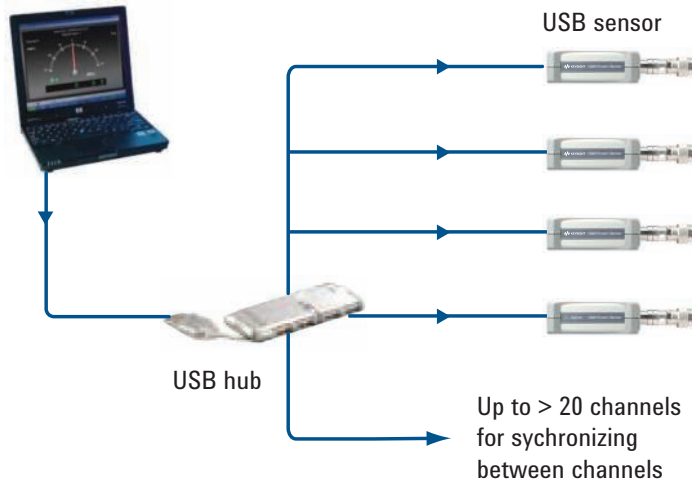

Figure 18. Multiple-channel remote power level measurement configuration.

The advantages of using a USB sensor for measuring power levels are many. They allow measuring power without a power meter, connect quickly and easily with USB 2.0, and perform accurate power measurements with other instruments. The USB power sensors can perform zeroing without disconnecting the power sensor from the device under test, and USB sensors do not require calibrating the sensor with a 1 mW reference signal. USB sensors are very linear and accurate, and can measure pulsed signals and the average power of a modulated signal. The feature packed software that is included with the USB sensors also provides quick and easy power level monitoring.

## Vector Network Analyzers and USB Power Sensors

VNAs can also use USB power sensors directly. For certain applications, such as measuring a mixer/frequency translation device with an embedded LO, using USB power sensors with a VNA may provide a cost effective solution. Embedded LOs tend to drift in frequency, and cannot be controlled precisely. Scalar network analyzers and USB power sensors have broadband detection capabilities, and can provide more accurate measurements than a tuned vector receiver in applications where the embedded LO is drifting by as much as half the vector analyzer's IF bandwidth. While a scalar analyzer system may have been used for this type of measurement in the past, a VNA with a USB power sensor would be an equivalent measurement configuration.

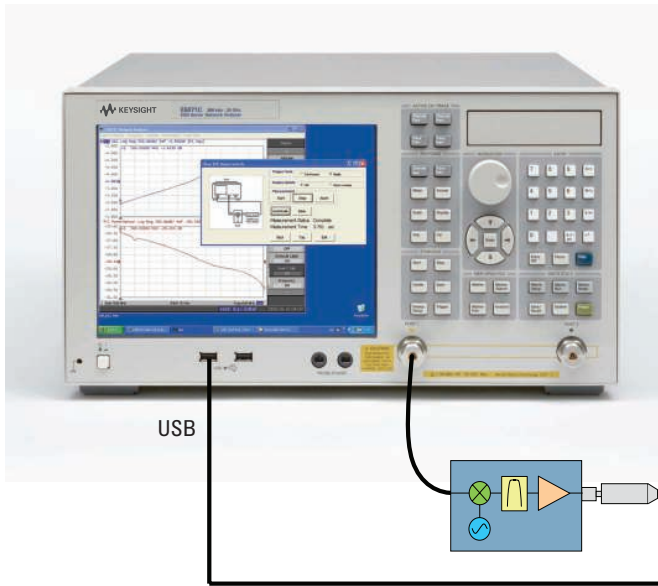

Figure 19. Measurement configuration for a frequency translation device with an embedded LO, utilizing a VNA and using a USB power sensor as a detector.

## Web Resources

Visit our Web sites for additional information and literature.

8757D Scalar Network Analyzer

[www.keysight.com/find/8757](http://www.keysight.com/find/8757)

Microwave and RF network analyzers:

[www.keysight.com/find/na](http://www.keysight.com/find/na)

ENA series network analyzers:

[www.keysight.com/find/ena](http://www.keysight.com/find/ena)

PNA series network analyzers:

[www.keysight.com/find/pna](http://www.keysight.com/find/pna)

FieldFox RF analyzer

[www.keysight.com/find/fieldfox](http://www.keysight.com/find/fieldfox)

USB power sensors

[www.keysight.com/find/usbsensor](http://www.keysight.com/find/usbsensor)

Mixer and converter applications:

[www.keysight.com/find/fca](http://www.keysight.com/find/fca)

Electronic calibration (ECal):

[www.keysight.com/find/ecal](http://www.keysight.com/find/ecal)

RF and microwave accessories:

[www.keysight.com/find/accessories7](http://www.keysight.com/find/accessories7)



**myKeysight**

[www.keysight.com/find/mykeysight](http://www.keysight.com/find/mykeysight)

A personalized view into the information most relevant to you.

**Keysight Channel Partners**

[www.keysight.com/find/channelpartners](http://www.keysight.com/find/channelpartners)

Get the best of both worlds: Keysight's measurement expertise and product breadth, combined with channel partner convenience.

Insert registered trademarks and copyright notes here. If none, remove row from table.

[www.keysight.com/find/na](http://www.keysight.com/find/na)

For more information on Keysight Technologies' products, applications or services, please contact your local Keysight office. The complete list is available at: [www.keysight.com/find/contactus](http://www.keysight.com/find/contactus)

**Americas**

Canada	(877) 894 4414
Brazil	55 11 3351 7010
Mexico	001 800 254 2440
United States	(800) 829 4444

**Asia Pacific**

Australia	1 800 629 485
China	800 810 0189
Hong Kong	800 938 693
India	1 800 112 929
Japan	0120 (421) 345
Korea	080 769 0800
Malaysia	1 800 888 848
Singapore	1 800 375 8100
Taiwan	0800 047 866
Other AP Countries	(65) 6375 8100

**Europe & Middle East**

Austria	0800 001122
Belgium	0800 58580
Finland	0800 523252
France	0805 980333
Germany	0800 6270999
Ireland	1800 832700
Israel	1 809 343051
Italy	800 599100
Luxembourg	+32 800 58580
Netherlands	0800 0233200
Russia	8800 5009286
Spain	800 000154
Sweden	0200 882255
Switzerland	0800 805353
	Opt. 1 (DE)
	Opt. 2 (FR)
	Opt. 3 (IT)
United Kingdom	0800 0260637

For other unlisted countries:  
[www.keysight.com/find/contactus](http://www.keysight.com/find/contactus)  
 (BP-09-23-14)

