

U3700 Series Options Guide

ADVANTEST



Option Guide

	Product name	Model number	Overview	Main unit support			
				U3741		U3751/3771/3772	
				1 ch	2 ch	1 ch	2 ch
50 Ω series ¹⁾	2 Channel input (50 Ω)	OPT.10	Addition of RF INPUT2 (9 kHz to 3 GHz) Individual RF measurement with RF INPUT 1 and RF INPUT 2	—	●	—	● ⁴⁾
	EMC filter	OPT.28	Addition of CISPR bandwidth for EMI measurement RBW (6 dB Down): 200 Hz, 9 kHz, 120 kHz, 1 MHz	●	●	●	●
	High-purity spectrum analysis ²⁾	OPT.70	Spectrum analysis with -102 dBc/Hz @ 10 kHz offset (Typical) Addition of RBW 30 Hz	●	×	●	×
	Tracking generator (3 GHz)	OPT.76	Frequency range: 100 kHz to 3 GHz Output level range: 0 to -60 dBm	●	●	● ³⁾	×
	Tracking generator (6 GHz)	OPT.77	Frequency range: 100 kHz to 6 GHz Output level range: 0 to -30 dBm	×	×	● ³⁾	×
75 Ω series ¹⁾	2 Channel input (75 Ω)	OPT.11	RF INPUT 2 (9 kHz to 2.2 GHz) in addition to OPT.15 Individual RF measurement with RF INPUT 1 and RF INPUT 2	—	●	—	×
	1 Channel input (75 Ω)	OPT.15	RF INPUT: 75 Ω (100 kHz to 2.2 GHz) For CATV and TV picture signal measurement. Channel table data installed.	●	—	×	—
	Tracking generator (2.2 GHz)	OPT.75	Frequency range: 100 kHz to 2.2 GHz. Output level range: 107 to 47 dBμV	●	●	×	×
Commons	High-stability frequency reference source	OPT.20	Reference oscillator with an aging rate of $\pm 2 \times 10^{-8}/\text{day}$, $\pm 1 \times 10^{-7}/\text{year}$	●	●	●	●
	Time-domain analysis (1 ch) ²⁾	OPT.53	Analyze the basic parameter of RF signal on a time domain (amplitude/phase/frequency/FFT/IQ/IQ output)	●	—	●	—
	Time-domain analysis (2 ch) ²⁾	OPT.54	Analyze the basic parameter of RF signal on a time domain (amplitude/phase/frequency/FFT/IQ/IQ output)	—	●	—	●

1) The options of 50 Ω series and 75 Ω series cannot be installed simultaneously. 2) OPT.70 cannot be installed simultaneously with OPT.53/54.
3) One must be selected from OPT.76/77.

● Available
× Not available

High-stability frequency reference source

OPT.20

Frequency of the high frequency signal was conventionally counted with a frequency counter. However, multi-carrier method is often employed for the recent communication system which uses high frequency signals which contains multiple frequency components, a frequency counter cannot count the frequency correctly. Therefore, the frequency counter of the spectrum analyzer attracts attention as an essential function. In a spectrum analyzer, just by pointing the marker at the spectrum separated as a sine wave of CW, not only the frequency

counting but also faint signal level counting is possible. OPT.20 improves the aging stability of the standard oscillator which determines the frequency counter accuracy of a spectrum analyzer.

	Aging rate
Standard	$\pm 2 \times 10^{-6}/\text{year}$
OPT.20	$\pm 2 \times 10^{-8}/\text{day}$, $\pm 1 \times 10^{-7}/\text{year}$

EMC filter

OPT.28

Option 28 adds 6 dB RBW CISPR bandwidths for EMI measurement of 200 Hz, 9 kHz, 120 kHz, and 1 MHz. A broadband sweep by the spectrum analyzer is very effective at measuring noise emitted from electrical devices. Installing OPT.28 allows measurement in CISPR-specified bandwidths. It enables simple, fast measurement using the Positive peak detector and Max Hold, which makes it effective at compensating for emitted noise. It guarantees an impulse bandwidth accuracy of 1 MHz. This capability conforms to the standard for noise measurement of 1 GHz or above.

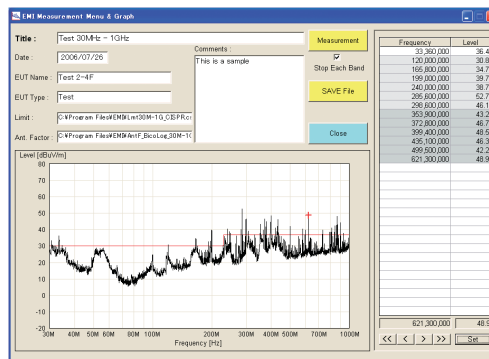

Measurement using EMI sample software

Two-channel input option (OPT.10/OPT.11) offers two independent lines of RF input. Various measurement conditions including measuring frequency and spans can be set independently for each RF input.

High-speed process by the parallel processing

- Simultaneous measurement of standard items (CH powers and OBW, etc.)
- Reduction in time by two-piece simultaneous measurement
- Simultaneous measurement of the different system, etc.
- Simultaneous measurement of different frequency (1 GHz or less and micro-wave) etc. at EMC measurement

Applications only possible for a two-channel spectrum analyzer

- Timing measurement between two channels by the synchronized sweep and synchronized trigger
- Simultaneous spectrum observation of the different frequency by the synchronized sweep when sweeping time is the same
- Simultaneous observation of the whole/part by the synchronized trigger
- Simultaneous monitoring of input/output devices



Simultaneous measurement of POWER and OBW

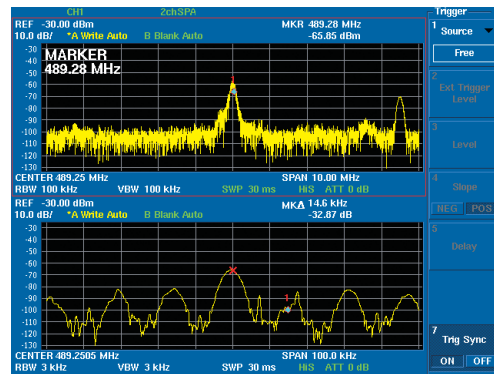

Simultaneous measurement of the broadband/narrowband by the synchronized sweep

Allocating Connectors on Front Panel (for U3741)

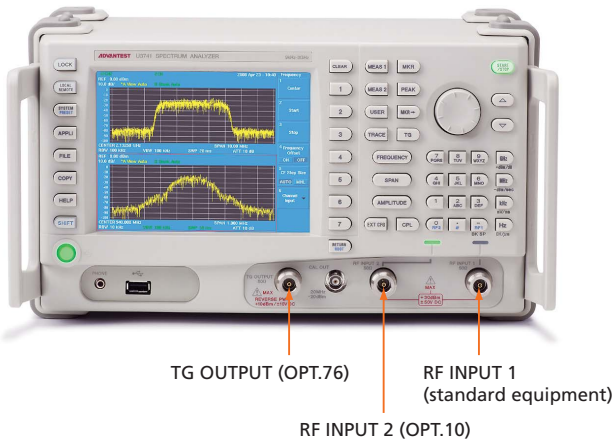

Simultaneous measurement of input/output for feed-forward amp

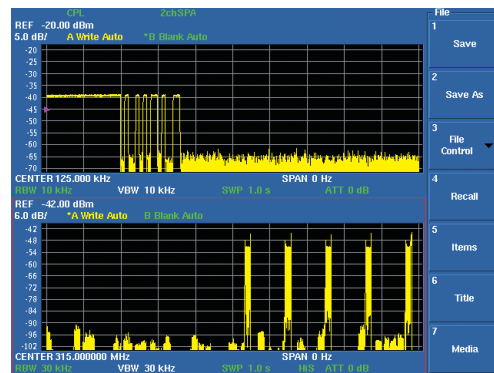

Timing measurement of TPMS by the synchronized trigger

Time-domain analysis

OPT.53
1 CH

OPT.54
2 CH

By installing this option in addition to the function of the conventional sweeping-type spectrum analyzer, a the time-domain analysis basic functions is added at low-cost.

Signal observation based on a domain different from sweeping-type spectrum analyzer

- Change in frequency over time by Freq. vs. Time analysis (ex. analysis of FSK signals, such as keyless entry and TPMS)
- Change in phase over time by Phase vs. Time analysis
- Change in power over time by Power vs. Time analysis
- High resolution (equivalent of 1 Hz RBW) high sensitivity measurement by FFT

Time-domain analysis for two signals (OPT.54)

The time-domain basic analysis function in the range of 9 kHz to 43 GHz (on main body) can be installed simultaneously for 2 channels. Unique analysis functions, such as Freq. vs Time during input and output are realized.

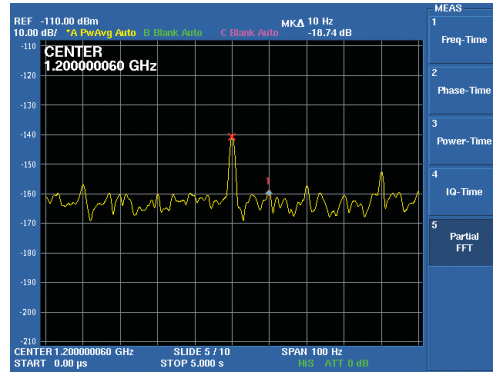

High sensitivity measurement by FFT (RBW 1Hz, -160dBm/Hz (typ))

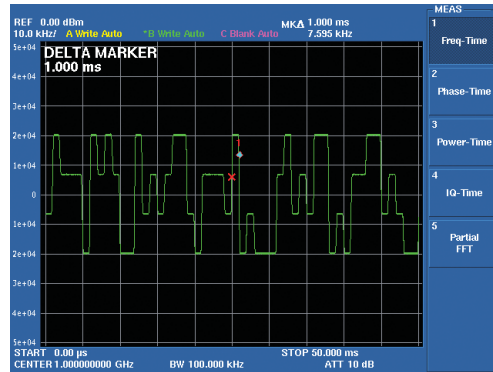

FREQ. vs. Time measurement of the 4 value FSK

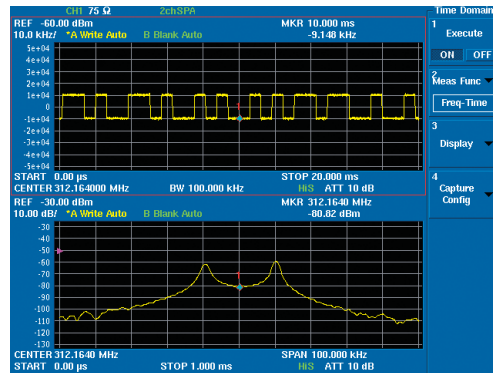

2 Ch time-domain basic analysis by OPT.54

Multi-Domain Analysis for a Modulation Signal

FFT Spectrum

Freq. vs. Time

Power vs. Time

Phase vs. Time

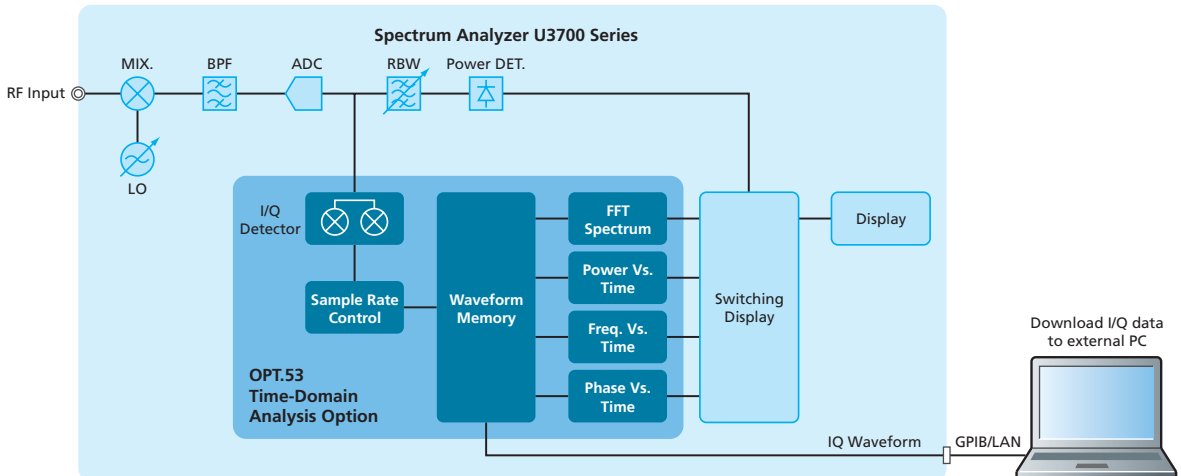

High-purity spectrum analysis

OPT.70

Phase noise measurement is indispensable to evaluation of the characteristics of high-frequency oscillation circuits or modules. The high-purity spectrum analysis option offered with the U3700 series can improve the phase noise measurement performance of the spectrum analyzer. Because the performance can be selected, selecting the most suitable spectrum analyzer for the device under test (DUT) is simple. At the same time, the added resolution bandwidth of 30 Hz enables reduction of the display average noise level and analysis in a high dynamic range.

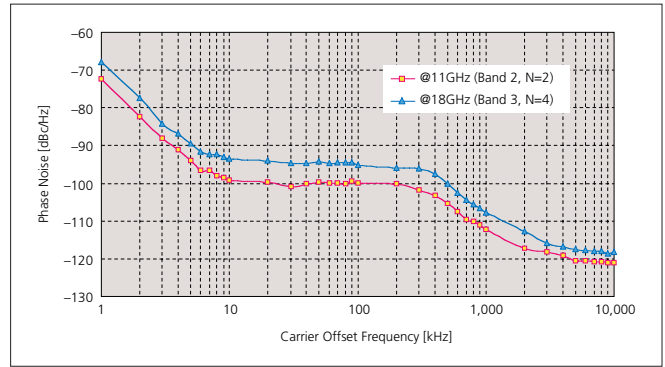

Phase noise characteristic graph (U3771/3772 representative values)

Tracking generator

OPT.75

OPT.76

OPT.77

Generates synchronized signals for frequency sweeps by the spectrum analyzer.

- OPT.75** Output impedance: 75 Ω
Output frequency range: 100 kHz to 2.2 GHz

- OPT.76** Output impedance: 50 Ω
Output frequency range: 100 kHz to 3 GHz
- OPT.77** Output impedance: 50 Ω
Output frequency range: 100 kHz to 6 GHz

Functions for evaluating frequency characteristics

The normalize function enables direct measurement of cable loss and filter characteristics. The frequency offset function of the tracking generator enables measurement of frequency characteristics and conversion loss characteristics of mixers and other frequency conversion devices.

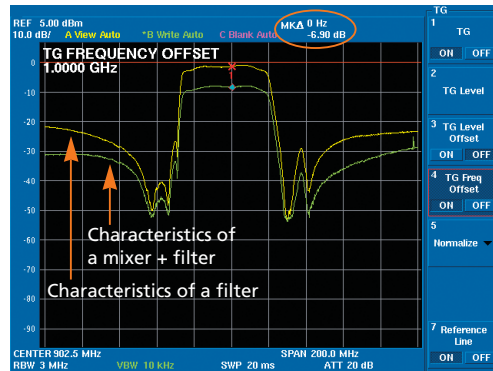
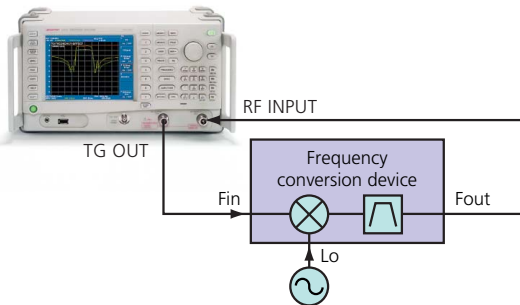

Measurement of mixer frequency conversion loss characteristics

Function for return loss measurement

The SWR bridge can be used to measure reflection characteristics of an antenna or filter. It can determine the return loss and evaluate the VSWR.

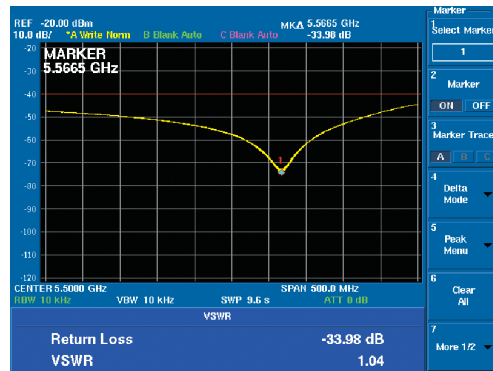
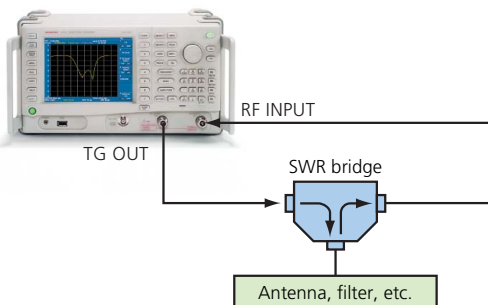

Filter return loss measurement

Specifications

OPT.10 2 Channel Input (50 Ω, 3 GHz)

Cross talk between input channels (between RF input 1 and RF input 2):	<-90 dBc (Input level -10 dBm, Input attenuator 0 dB, Preamplifier off)
RF input 2	
Connector:	N type female
Impedance:	50 Ω (nominal)
VSWR:	<1.5 : 1 (Input attenuator > 10 dB)
External trigger input:	An external trigger input can be selected as a trigger input of RF input 2 when installing the OPT.10. The input connector is only 1 system.
21.4 MHz IF output:	Only IF output which supports RF input 1, when installing the OPT.10.

Except for all items mentioned above, the frequency, sweep, amplitude range, amplitude accuracy, dynamic range, input/output, and performance of specifications follow the standard specifications of the RF input 1 option of the U3741 spectrum analyzer.

OPT.11 2 Channel Input (75 Ω, 2.2 GHz)

Cross talk between input channels (between RF input 1 and RF input 2):	<-90 dBc (Input level 98.8 dBμV, Input attenuator 0 dB, Preamplifier off)
RF input 2	
Connector:	N type female
Impedance:	75 Ω (nominal)
VSWR:	<1.5 : 1 (Input attenuator > 10 dB)
External trigger input:	An external trigger input can be selected as a trigger input of RF input 2 when installing the OPT.11. The input connector is only 1 system.
21.4 MHz IF output:	Only IF output which supports RF input 1, when installing the OPT.11.

Except for all items mentioned above, the frequency, sweep, amplitude range, amplitude accuracy, dynamic range, input/output, and performance of specifications follow the standard specifications of the RF input 1 option of the U3741 + OPT.15 spectrum analyzer.

OPT.20 High-Stability Frequency Reference Source

Frequency reference stability	
Aging rate:	±2 x 10 ⁻⁵ /day ±1 x 10 ⁻⁷ /year
Warm-up drift:	±5 x 10 ⁻⁶ (+25°C, 10 minutes after power-on)
Temperature stability:	±5 x 10 ⁻⁶ (0 to +40°C, with reference to 25°C)

OPT.28 EMC Filter

6 dB bandwidth:	200 Hz, 9 kHz, 120 kHz, 1 MHz
Bandwidth accuracy:	< ±10%

OPT.53 Time-Domain Analysis (1 ch)

RF range:	Follows U3700 series models.
RF amplitude range:	Noise level to +30 dBm ^{*1)}
Wave recording method:	I/Q vector time waveform
Measuring bandwidth (BW):	100 Hz to 3 MHz (1 to 3 steps)
IQ sampling rate:	713 Hz (BW 100 Hz) to 21.4 MHz (BW 3 MHz)
IQ waveform recording time:	49 msec (BW 3 MHz) to 1000 sec (BW 100 Hz)
Number of IQ waveform recording samples:	1 M samples (I/Q)

*1) The noise level follows the dynamic range of the U3700 series products.

OPT.54 Time-Domain Analysis (2 ch)

RF range:	Follows U3700 series models.
RF amplitude range:	Noise level to +30 dBm ^{*1)}
Wave recording method:	I/Q vector time waveform
Measuring bandwidth (BW):	100 Hz to 3 MHz (1 to 3 steps)
IQ sampling rate:	713 Hz (BW 100 Hz) to 21.4 MHz (BW 3 MHz)
IQ waveform recording time:	49 msec (BW 3 MHz) to 1000 sec (BW 100 Hz)
Number of IQ waveform recording samples:	1 M samples (I/Q)

*1) The noise level follows the dynamic range of the U3700 series products.

OPT.70 High-Purity Spectrum Analysis

Frequency span	
Range:	1 kHz to Full, zero span
Accuracy:	< ±1%
Resolution bandwidth	
Range:	U3741: 30 Hz to 1 MHz (1 to 3 steps) U3751: 30 Hz to 3 MHz (1 to 3 steps)
Accuracy:	< ±12%
Spectrum purity:	≤ -98 dBc/Hz (offset 10 kHz, span ≤ 1 MHz) -102 dBc/Hz (Typical)
Displayed average noise level:	Reference level < -45 dBm, Resolution bandwidth 30 Hz
U3741:	Frequency 10 MHz to 3 GHz
Pre-Amp OFF:	-126 dBm + 2f (GHz) dB (f < 2.5 GHz) -126 dBm + 2.5f (GHz) dB (f ≥ 2.5 GHz)
Pre-Amp ON:	-141 dBm + 3f (GHz) dB
U3751:	Frequency 10 MHz to 8 GHz
Pre-Amp OFF:	-126 dBm + 2f (GHz) dB (f ≤ 3.1 GHz, band 0) -125 dBm + 1f (GHz) dB (f ≥ 3 GHz, band 1)
Pre-Amp ON:	-141 dBm + 3f (GHz) dB (f ≤ 3.1 GHz, band 0) -142 dBm + 1.3f (GHz) dB (f ≥ 3 GHz, band 1)

OPT.75 Tracking Generator (75 Ω, 2.2 GHz)

Frequency range:	100 kHz to 2.2 GHz
Frequency offset	
Range:	0 Hz to 1 GHz
Accuracy:	±300 Hz
Resolution:	1 kHz
Output level range:	107 to 47 dBμV (0.5 dB steps)
Output level accuracy:	±0.5 dB (20 MHz, 97 dBμV, +20 to +30°C)
Output level flatness:	Using 20 MHz and 97 dBμV as a reference ±1.0 dB (1 MHz to 1 GHz) ±1.5 dB (100 kHz to 2.2 GHz)
Output level switch error:	Using 20 MHz and 97 dBμV as a reference ±1.0 dB (1 MHz to 1 GHz, 107 to 47 dBμV) ±2.0 dB (1 MHz to 2.2 GHz, 107 to 47 dBμV)
Frequency offset OFF:	±3.0 dB (100 kHz to 2.2 GHz, 107 to 77 dBμV) ±4.0 dB (100 kHz to 2.2 GHz, 76.5 to 47 dBμV)
Frequency offset ON:	±5.0 dB (100 kHz to 2.2 GHz)
Output spurious:	Output level 97 dBμV
Harmonic:	< -15 dBc (100 kHz to 1 MHz) < -20 dBc (1 MHz to 2.2 GHz)
Non-harmonic:	< -20 dBc (Frequency offset OFF)
TG leakage:	< 31 dBμV (Input attenuator 0 dB)
Output impedance:	75 Ω (nominal)
VSWR:	≤ 2.0 : 1 (Output level ≤ 97 dBμV)
Maximum allowable level:	117 dBμV, ±10 VDC

OPT.76 Tracking Generator (50 Ω, 3 GHz)

Frequency range:	100 kHz to 3 GHz
Frequency offset	
Range:	0 Hz to 1 GHz
Accuracy:	±300 Hz
Resolution:	1 kHz
Output level range:	0 to -60 dBm (0.5 dB steps)
Output level accuracy:	±0.5 dB (20 MHz, -10 dBm, +20 to +30°C)
Output level flatness:	Using 20 MHz and -10 dBm as a reference ±1.0 dB (1 MHz to 1 GHz) ±1.5 dB (100 kHz to 3 GHz)
Output level switch error:	Using 20 MHz and -10 dBm as a reference ±1.0 dB (1 MHz to 1 GHz, 0 to -60 dBm) ±2.0 dB (1 MHz to 2.6 GHz, 0 to -60 dBm)
Frequency offset OFF:	±3.0 dB (100 kHz to 3 GHz, 0 to -30 dBm) ±4.0 dB (100 kHz to 3 GHz, -30.5 to -60 dBm)
Frequency offset ON:	±5.0 dB (100 kHz to 3 GHz)
Output spurious:	Output level -10 dBm
Harmonic:	< -15 dBc (100 kHz to 1 MHz) < -20 dBc (1 MHz to 3 GHz)
Non-harmonic:	< -20 dBc (Frequency offset OFF)
TG leakage:	< -80 dBm (Input attenuator 0 dB)
Output impedance:	50 Ω (nominal)
VSWR:	≤ 2.0 : 1 (Output level ≤ -10 dBm)
Maximum allowable level:	+10 dBm, ±10 VDC

OPT.77 Tracking Generator (50 Ω, 6 GHz) ^{*2)}

Frequency range:	100 kHz to 6 GHz
Output level range:	0 to -30 dBm (0.5 dB step)
Output level accuracy:	≤ ±0.5 dB (20 MHz, -10 dBm, +20 to +30°C)
Output level flatness:	20 MHz on -10 dBm criterion, at +20 to +30°C ≤ ±1 dB (1 MHz to 1 GHz) ≤ ±1.5 dB (100 kHz to 3.1 GHz) ≤ ±2.0 dB (100 kHz to 6 GHz)
TG leakage:	≤ -80 dBm (input attenuator: 0 dB)
Output impedance:	50 Ω (nominal)
VSWR:	≤ 2.0 : 1 (Output level ≤ -10 dBm)
Maximum allowable level:	+10 dBm, ±10 VDC

*2) The OPT.77 is not allowed to be installed on the U3741.

A199001 6 GHz VSWR Bridge

Frequency range:	100 MHz to 6 GHz
Directivity:	≥34 dB (100 MHz to 1 GHz) ≥29 dB (1 to 3.8GHz) ≥25 dB (3.8 to 6GHz)
Maximum input power:	+15 dBm (Input Port)
DC voltage:	±30 VDC (Test Port)
Connector:	SMA (female)
External dimensions	
(W x H x D):	Approx. 103 x 35 x 20 mm
Mass:	100 g or less

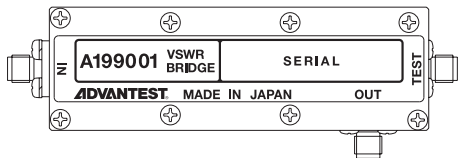

Ordering Information

Options	
2 channel input (50 Ω, 3 GHz):	OPT.10
2 channel input (75 Ω, 2.2 GHz):	OPT.11
1 channel input (75 Ω):	OPT.15
High-stability frequency reference source:	OPT.20
EMC filter:	OPT.28
Time-domain analysis (1 ch):	OPT.53
Time-domain analysis (2 ch):	OPT.54
High-purity spectrum analysis:	OPT.70
Tracking generator (75 Ω, 2.2 GHz):	OPT.75
Tracking generator (50 Ω, 3 GHz):	OPT.76
Tracking generator (50 Ω, 6 GHz):	OPT.77
Main units	
3 GHz spectrum analyzer:	U3741
8 GHz spectrum analyzer:	U3751
31.8 GHz spectrum analyzer:	U3771
43 GHz spectrum analyzer:	U3772
Accessory	
6 GHz VSWR bridge:	A199001

Please refer to product manual for complete system specifications.
Specifications may change without notification.

ADVANTEST[®]

<http://www.advantest.co.jp>

ADVANTEST CORPORATION
Shin-Marunouchi Center Building, 1-6-2 Marunouchi, Chiyoda-ku, Tokyo 100-0005, Japan Phone: +81-3-3214-7500