

Keysight Technologies

Infiniium DCA-X

86100D Wide-Bandwidth Oscilloscope Mainframe and Modules

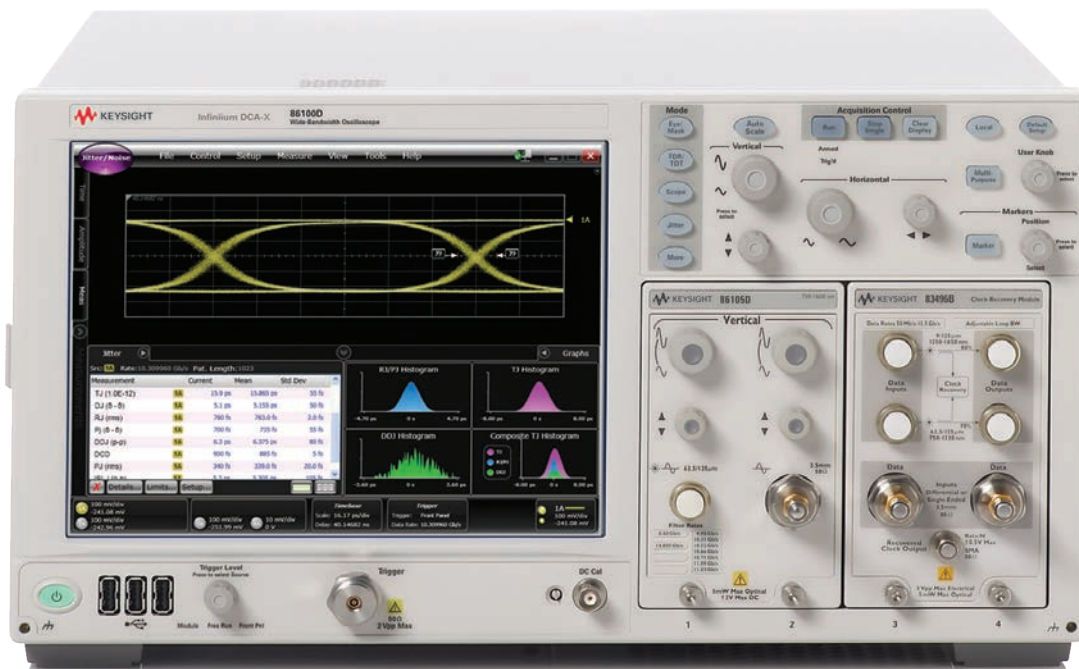

See the TRUE performance of your designs.

The 86100D DCA-X is the premier solution for accurate and precise measurements on high-speed digital designs from 50 Mb/s to over 80 Gb/s. Applications include:

- Optical-Transceiver design and manufacturing compliance test
- Electrical-ASIC/FPGA/IC design and channel characterization
- TDR/TDT/S-parameter-Serial bus design, cable, and PCB channel characterization

The DCA-X provides powerful analysis and measurement insight for the novice and expert user alike:

- Scope, eye diagram and mask testing
- Jitter and amplitude analysis
- Equalization, de-embedding, and embedding
- Phase locked loop (PLL) analysis
- Phase noise analysis

These basic instrument modes are further complemented by the following features that provide additional insight and analysis capability:

- De-embedding, embedding, equalizer capability
- Phase Noise/Jitter Spectrum Analysis
- Phase Locked Loop (PLL) Analysis
- Custom analysis (MATLAB)
- And more...

Overview of the Infiniium DCA-X

The 86100D DCA-X can be viewed as four powerful instruments in one:

Scope mode

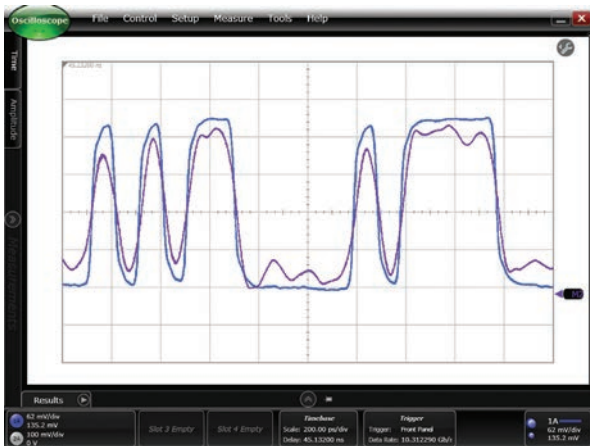

A full function oscilloscope providing high-fidelity waveform characterization

Jitter mode

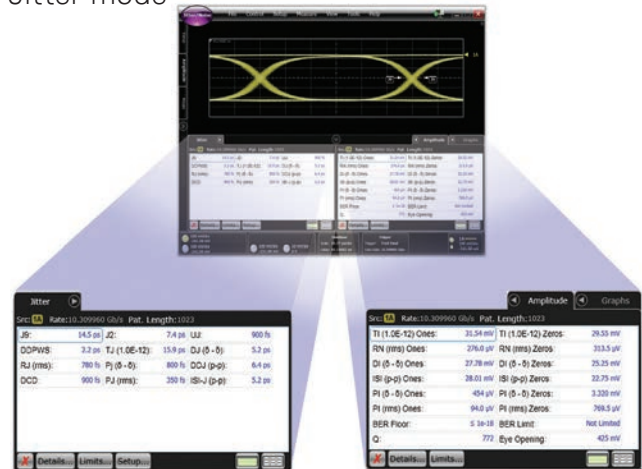

Precision jitter, amplitude, and frequency analysis capability

Eye/Mask mode

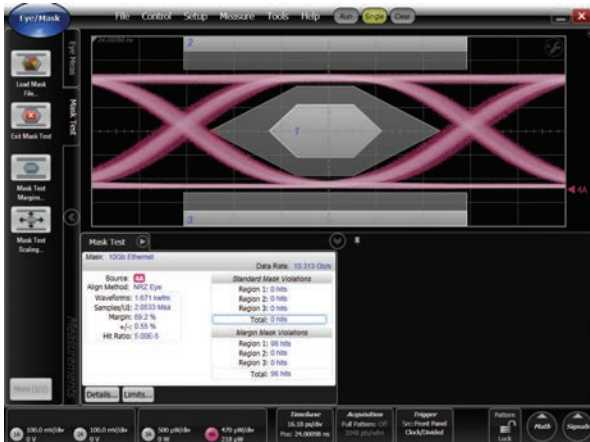

A digital communication analyzer providing fast transmitter characterization using eye diagram analysis, calibrated reference receivers, and automated mask margin measurements

TDR/TDT mode

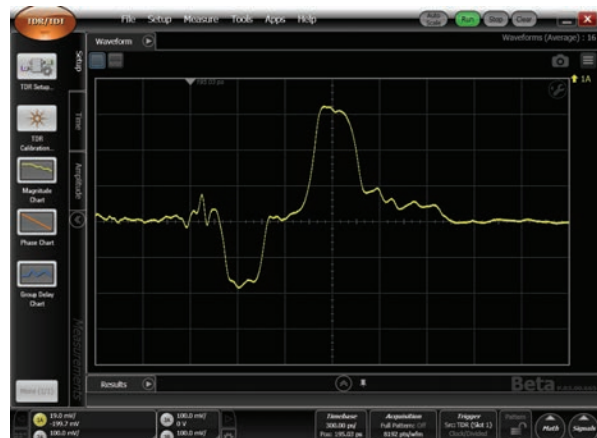

Accurate time domain reflectometry/transmission impedance and S-Parameter measurements

Benefits

The DCA-X provides users with a variety of benefits:

Improved margins, differentiated products

Standards are continually moving towards faster and faster data rates in response to market demands. As a result, data signals have shorter bit periods and faster edge speeds. In order for digital communication systems to approach error-free performance, engineers often employ techniques such as emphasis and equalization, and they take great care to minimize jitter and noise impairments on their signals.

The 86100D DCA-X is architected to provide the optimum combination of wide-bandwidth, low noise, and low jitter so that you measure the TRUE performance of your design, not the scope itself.

With bandwidth >90GHz, jitter <50fs, and noise as low as 250uV, the DCA-X provides industry-leading waveform fidelity that yields:

- more accurate waveform measurements
- lower jitter measurements
- improved mask margins, higher yields

With the addition of Option SIM InfiniSim-DCA, signal degradation due to fixtures or cables can be removed, or de-embedded, providing even more margin. Alternatively, it is also possible to simulate the signal at the end of a fixture or cable (embedding) for additional insight or compliance.

Industry standard compliance

The DCA makes it easy to perform industry standard compliance measurements accurately and quickly.

The 86100D provides:

- Over 50 built-in standards-based masks with automated mask margin analysis
- Optical reference receivers with the widest data rate coverage in the industry
- Fast, accurate, and compliant jitter measurements

Lower cost of test

Increased channel density and fast measurement functions and algorithms (such as fast Auto Scale and ER tuning) result in lower cost of test per port.

- High density channel count configurations
- Optimized algorithms for high volume manufacturing

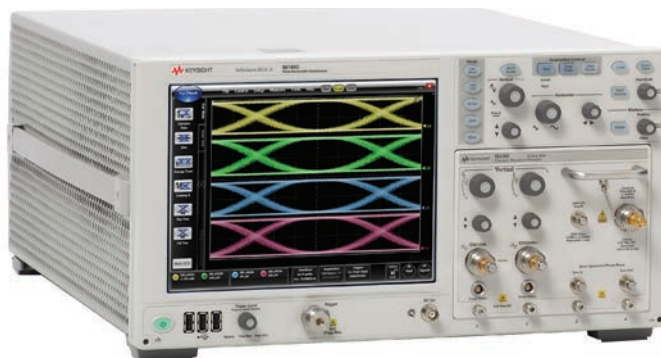

Faster time to market

Start making meaningful measurements quickly and get your product to market faster. With the ability to acquire and analyze up to 16 signals simultaneously, the 86100D DCA-X reduces the time to characterize high-speed designs. Additionally, the DCA-X user interface has been designed so that novice users quickly become proficient scope users.

- One-button mode buttons quickly configure standards-based measurements
- Built-in SCPI recorder to assist in creating automated test code
- Customizable displays

Upgradeable and backwards compatible

The modular architecture of the 86100D means that the instrument can evolve to meet your needs. There's no need to purchase capability until you need it.

- Modular - add capacity and/or new capabilities
- Protect your investment
 - 100% backwards compatible with all DCA modules (used with 54750A, 83480A, 86100A/B/C mainframes)
 - 100% code compatible with 86100C DCA-J
- Plan for the future - the DCA-X supports future modules and new measurement capability
- Optimized algorithms for high volume manufacturing

The 86100D Infiniium DCA-X Wide-Bandwidth Oscilloscope— Engineered for unmatched measurement accuracy, insight, and ease-of-use

High-resolution touch screen display

See your signal more clearly with a larger 10.4" XGA (1024 x 768) high-resolution color touch screen display

Dual user interfaces

A dual user interface comes standard. FlexDCA enables next generation measurement capability while the classic DCA-J user interface provides 100% backwards compatibility

FlexDCA Remote Access Software

The new user interface is also available as N1010A FlexDCA Remote Access Software, a PC-based application that provides connected (via LAN) and offline operation

Easy access to USB ports

Three front panel USB 2.0 host ports for your USB keyboard, mouse, and memory stick

De-embedding / embedding capability

Integrated de-embedding/embedding capability using 86100D-SIM InfiniiSim-DCA removes signal degradation from fixtures and provides greater insight

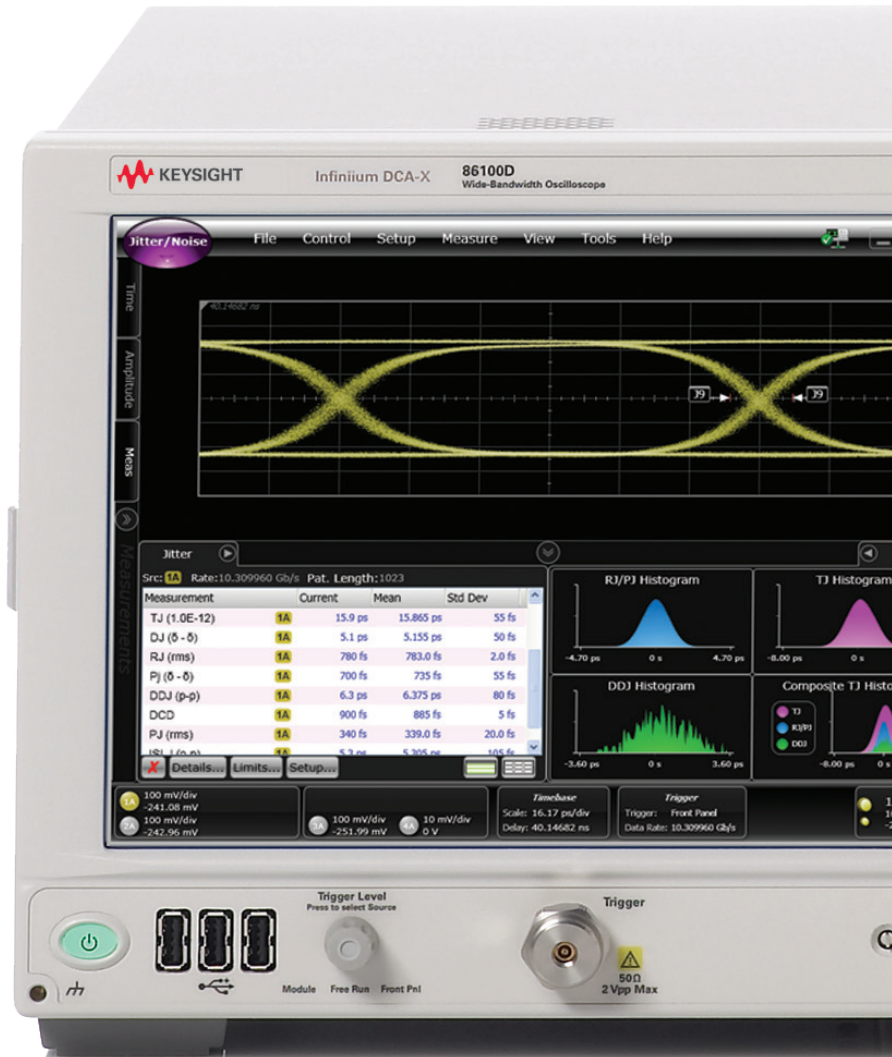

Display and document results quickly

Display up to 64 measurements simultaneously, ideal for documenting your results.

Probing

30 GHz differential and single-ended probing capability is available for the DCA Series scopes using the InfiniiMax III probing system and the N5477A probe adapter.

Dedicated mode buttons

One-touch Mode buttons quickly configure standards-based measurements

Customizable controls

Vertical gain and offset controls can be assigned to any channel or math function for quick and easy amplitude adjustments

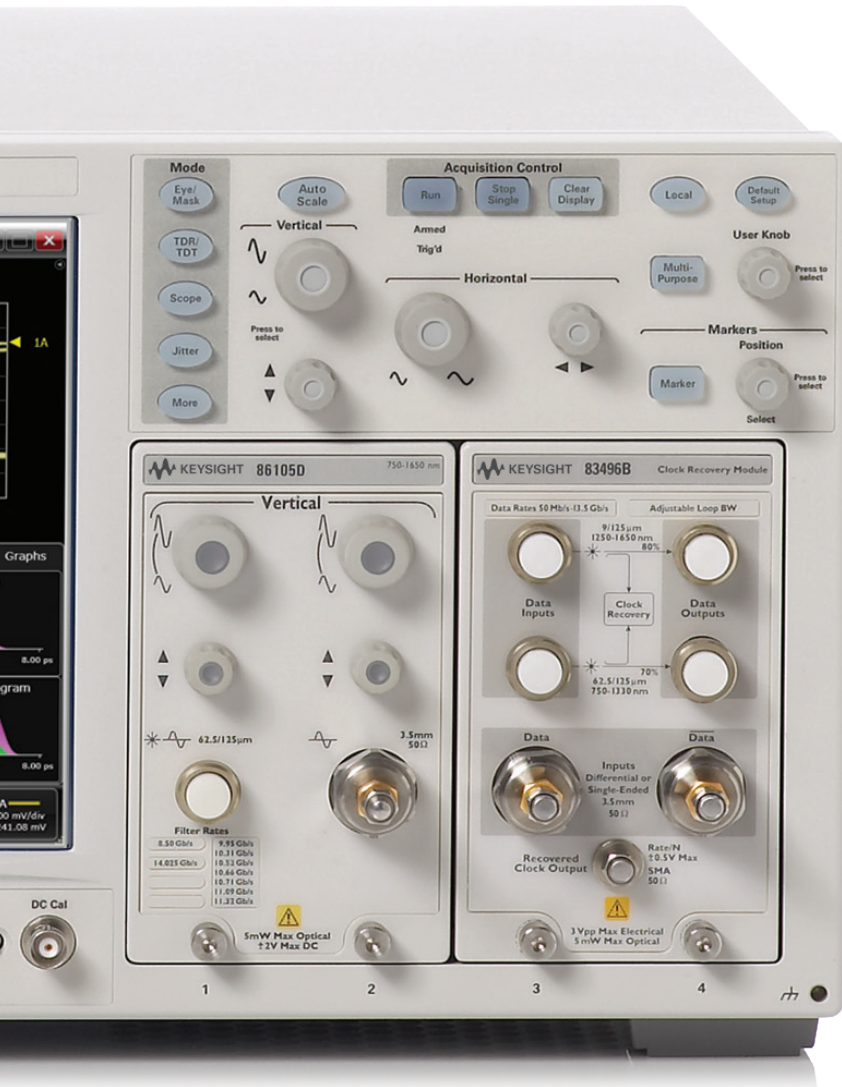

One-touch operation

Customizable multipurpose key can be configured to print/save screen shots, save waveforms or load a favorite setup.

Analog control

The User Knob controls any analog entry area that is active, making adjustments easier and faster than keying in numbers from a keypad.

Easy-to-use marker controls

Control multiple markers without lifting your fingers off of the controls! Simply push the knob to select another marker and start making adjustments quickly and easily.

Compatible

Fully backwards compatible with ALL legacy DCA modules (from 54750A, 83480A, and 86100A/B/C mainframes)

Modular

Choose from a variety of plug-in modules that perform precision optical, electrical, and TDR/TDT measurements. Select modules to obtain the specific bandwidth, filtering, and sensitivity that matches your measurement needs.

Foundation for the future

Supporting up to 16 measurement channels and next generation modules, the 86100D DCA-X provides the foundation for efficient testing of high-density ASIC / FPGA / SERDES and parallel designs

86100D DCA-X overview

Precision measurements on high-speed digital designs from 50 Mb/s to over 80 Gb/s

Applications include:

Optical

- Transceiver design and manufacturing compliance test

Electrical

- ASIC/FPGA/SERDES/IC design and characterization

TDR/TDT/S-parameter

- Serial bus design, cable and PCB characterization



86100D mainframe hardware options

Trigger and timebase options¹

- Option STR - Standard Trigger
For basic eye diagram measurements
- Option ETR - Enhanced Trigger
For pattern waveform and more advanced measurements such as jitter analysis. Option ETR increases trigger bandwidth to > 13 GHz adds pattern trigger capability, adds pattern waveform save capability for post-processing (up to 4096 samples/bit, up to 2²³ bits long), and adds support for clock recovery triggering through the module bay.
- Option PTB - Internal Precision Timebase
For accurate analysis of signals with low random jitter. Option PTB reduces the intrinsic timebase jitter of the oscilloscope to < 100 fs rms. Requires Option ETR.

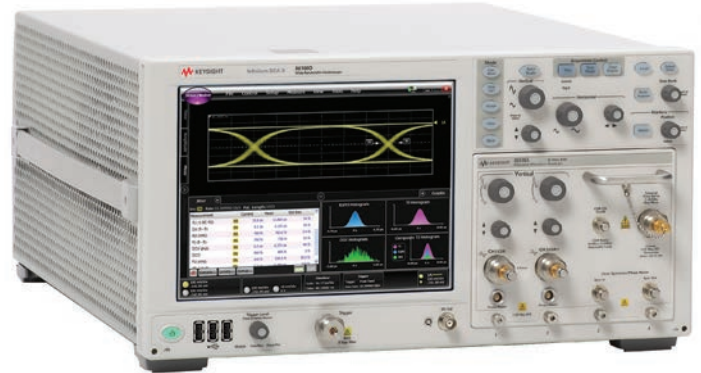

A standard unit may be upgraded later by ordering 86100DU-ETR or 86100DU-PTB, as appropriate.

Hard drive option

- Option 090 - Removable hard drive
- Option 092 - Fixed internal hard drive (default)

GPIO option

- Option GPI - GPIB card, factory installed (default)
- Option GPN - No GPIB card interface

To add a GPIB card later, order Keysight Technologies, Inc. part number 82351A or contact your local Keysight service center.

1. 86100D-ETR is recommended when using any DCA module equipped with a rear-panel trigger circuit. Examples include 54754A, 83496x, and 86108A/B modules. If operating these modules in an 86100D with Option STR, an external cable (such as P/N 5062-6690) must be connected from the module's front panel trigger/clock output to the 86100D's trigger input.

86100D DCA-X overview (continued)

Dual user interfaces

(standard with every 86100D)

The 86100D DCA-X includes two user interfaces for even greater ease-of-use and 100% backwards compatibility with the 86100C DCA-J. Switch between FlexDCA, the new vector-based interface, and the classic DCA user interface, at the touch of a button.

FlexDCA user interface

- De-embedding, embedding using Option SIM
- Jitter on long patterns (PRBS31), DDPWS, J2, J9 using 86100D Options 200/401
- Graphical signal processing
- Up to 64 simultaneous measurements

"Classic" DCA user interface

- Provides 100% backwards compatibility with the 86100C DCA-J

Same familiar user-interface that was used on earlier 86100 Series oscilloscopes

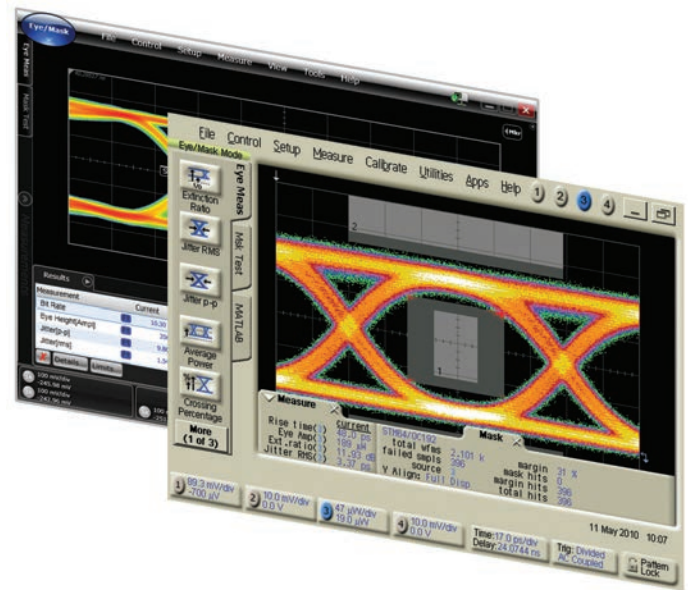

Eye diagram analysis and mask testing

(standard with every 86100D)

Characterize high-speed transmitters and transceivers quickly and accurately. Eye/Mask mode offers:

- Accurate Extinction Ratio and eye measurements
- Industry standard mask testing with built-in margin analysis
- '1' and '0' levels, jitter, rise or fall times and more
- Simultaneous acquisition on up to 16 channels provides highest throughput
- Parallel mask testing on up to 16 channels

For more detailed information:

www.keysight.com/find/86100D

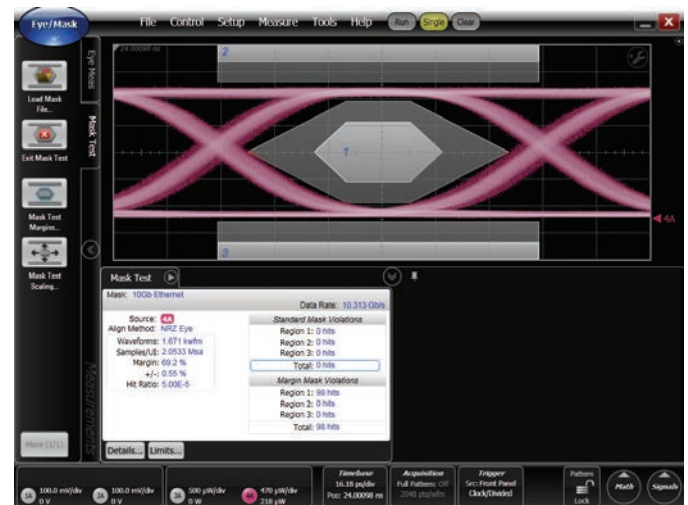

86100D DCA-X overview (continued)

Oscilloscope measurements (standard with every 86100D)

Highest accuracy waveforms. Wide-bandwidth, low-noise, and low-jitter samples result in accurate waveform measurements.

- Comprehensive time measurements such as rise time, fall time, jitter rms, jitter p-p
- Amplitude measurements such as Vamp1, Vpp, overshoot, Vrms, OMA
- Display and measure simulated waveforms

For more detailed information:
www.keysight.com/find/86100D

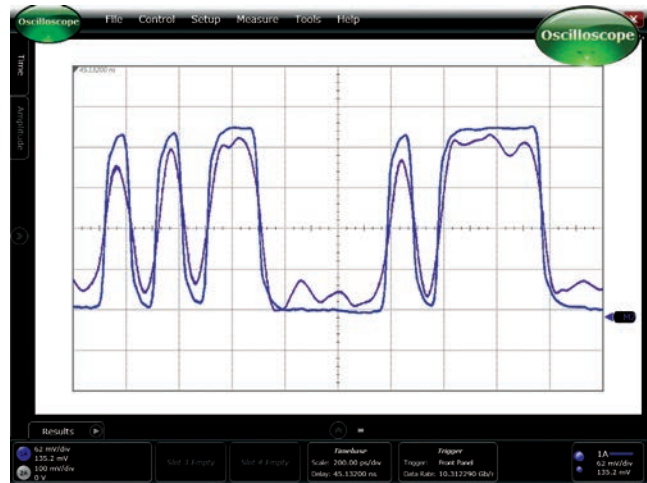

Time domain reflectometry/transmission (TDR/TDT)

(86100D with 54754A and N1055A1)

Precision impedance and S-parameter measurements on serial bus designs, cables, and printed circuit boards

Accurate impedance measurements

Integrated TDR calibration de-embeds cable and fixture losses (TDR Calibration is standard with every 86100D)

Live S-parameters at the touch of a single button

For more information, refer to the section on Enhanced Impedance and S-parameter software on page 11

Easy to use

Visual guides for novice and expert users

High channel count for greater throughput

Up to 16 TDR/TDT channels per 86100D mainframe

Fast and easy TDR/TDT calibration

Supports electronic calibration (ECal) modules for fast calibration and de-skew that yield more accurate results

Variable rise time

Increase the edge speed (e.g. to sub-10 ps) to locate closely spaced discontinuities; or decrease the edge speed (e.g. 50-200 ps) to emulate system level performance

Advanced signal integrity analysis using N1930B

Physical Layer Test System (PLTS)

For more detailed information refer to:
www.keysight.com/find/tdr



1. 86100D-ETR recommended.

86100D DCA-X overview (continued)

Jitter analysis (86100D-200¹)

As data rates increase in both electrical and optical applications, jitter is an ever increasing design and measurement challenge. The DCA-X provides:

- Simple, one button execution of jitter analysis
- Compliant, fast and accurate results on both optical and electrical signals
- Automated jitter decomposition into:
 - TJ/RJ/DJ/PJ/DDJ/ISI/DCD
 - UJ/J2/ J5/J9/DDPWS and more...
- Bounded Uncorrelated Jitter (BUJ) analysis

For more detailed information:
www.keysight.com/find/86100D-200



1. Requires 86100D-ETR.

Amplitude and noise analysis/RIN/Q-Factor (86100D-300²)

In addition to jitter, signal quality can also be impacted by impairments in the amplitude domain. Option 300 helps identify root cause of signal degradation in the ONE and ZERO level of the signal.

- Automated separation into: total interference (TI), random noise (RN), deterministic interference (DI), bounded uncorrelated noise (BUN), bounded uncor-related interference (BUI) and inter-symbol interference (ISI)
- Relative intensity noise (RIN), a common optical transceiver measurement
- Q-Factor, a figure of merit derived from the eye diagram

For more detailed information:
www.keysight.com/find/86100D-300

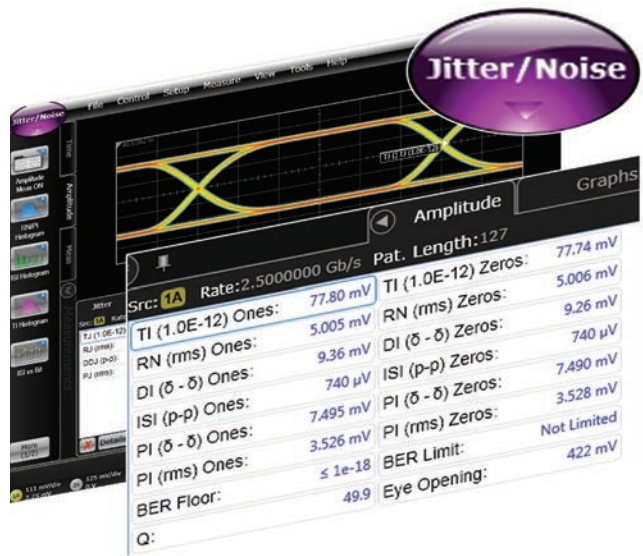

2. Requires 86100D-ETR/200

86100D DCA-X overview (continued)

De-embedding/embedding capability (86100D-SIM InfiniiSim-DCA)

Improve insight and design margins and comply with new standards based measurements. InfiniiSim-DCA provides an intuitive graphical interface that helps users:

- Improve margin by removing signal degradation caused by fixtures and cables (de-embedding)
- Simulate the signal at the end of a user-defined fixture or cable (embedding)
- Predict performance at a location you cannot directly observe
- Any measurement available for live signals can also be performed on simulated signals (jitter, waveform, eye analysis)

For more detailed information:

www.keysight.com/find/86100D-SIM

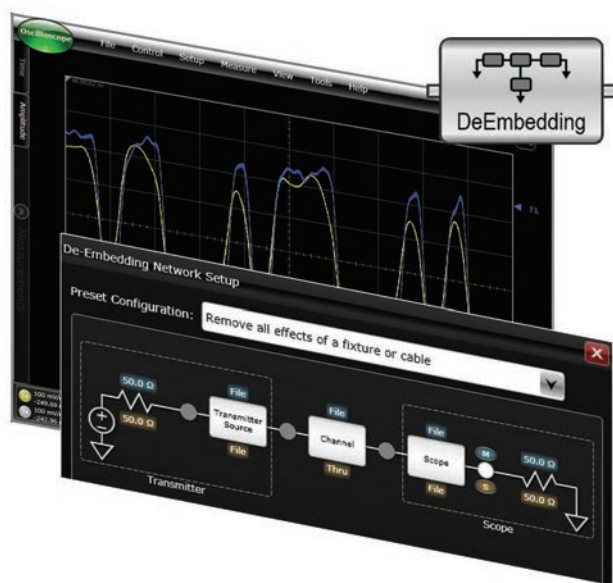

MATLAB – custom measurements (86100D-061/062¹)

MATLAB® is a powerful data analysis software environment and scripting language. It can be purchased directly from Keysight and installed on your scope to extend the functionality of your DCA-X².

- Create custom measurements using Matlab, displayed real-time on the DCA-X and similar to built-in measurements
- Design and apply your own filters or functions to waveforms
- Visualize signals using 2-D and 3-D plots

For more information:

www.keysight.com/find/matlab_oscilloscopes

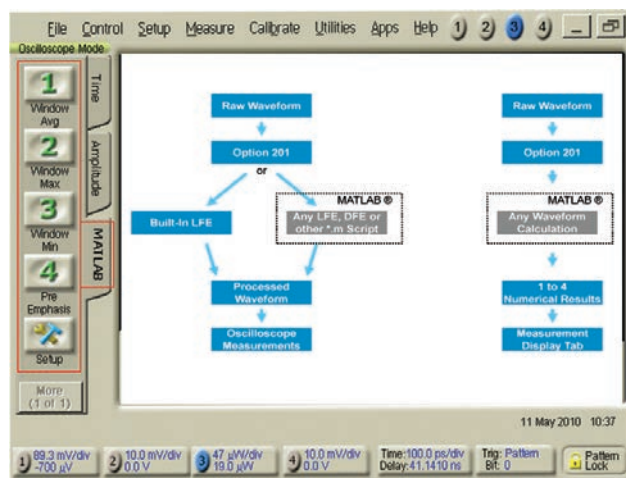

1. Requires 86100D-201.
2. Integrated operation with classic DCA user interface only.

86100D DCA-X overview (continued)

Equalization/deep memory waveform capture/Matlab interface (86100D-201)

Accelerate your design cycle using these powerful tools:

- Built-in equalizers
 - Simulate equalizer designs on actual signals before designing hardware
 - Linear feedforward equalizer (LFE/FFE)
 - Decision feedback equalizer (DFE)
 - Continuous-time linear equalizer (CTLE)
- Deep waveform memory capture²
 - Save .csv files up to 4096 samples/bit, up to 2²³ bits long; ideal for post-processing
- Real-time, integrated MATLAB interface³
 - Create custom measurements in MATLAB and have the scope display the results in real-time (MATLAB sold separately)

For more information:

www.keysight.com/find/86100D-201

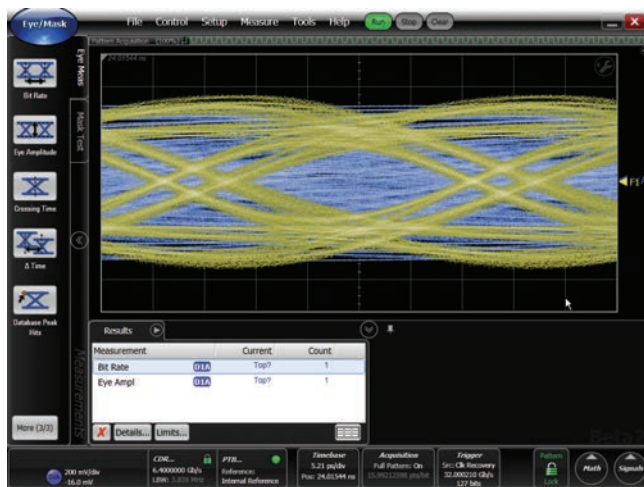

1. Requires 86100D-ETR.
2. This is a standard feature when using the FlexDCA user interface.
3. Integrated operation with classic DCA user interface only

Enhanced impedance and S-parameter software (86100D-202)

Accurately characterize serial bus designs, cables, and printed circuit boards. 86100D-202 complements TDR/TDT mode to provide:

- Integrated, calibrated and real-time S-parameter measurements – ideal for MFG and R&D
- S-parameters include magnitude, phase and group delay (user selectable)
- Accurate return loss, insertion loss (attenuation), near-end cross talk (NEXT), Far-end cross talk (FEXT), phase, and group delay measurements
- TDR peeling – remove unwanted effects from multiple reflections

For more information, refer to

www.keysight.com/find/86100D-202

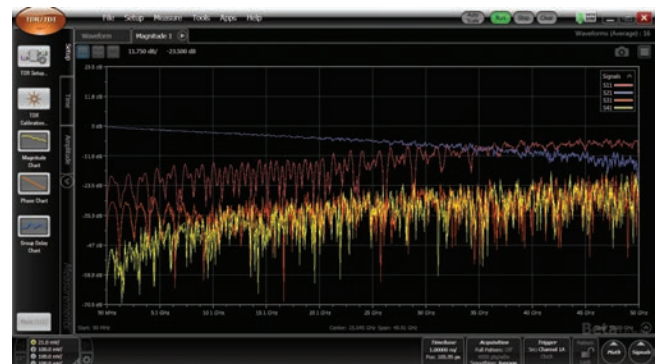

86100D DCA-X overview (continued)

Phase locked loop (PLL) and phase noise measurements (86100DU-4001)

Phase Locked Loops (PLL) are used in a wide variety of applications including clock extraction circuits, multiplier/dividers, and PLLs. Understanding their performance is of critical importance due to their influence on jitter. Option 400 is a PC based application that characterizes PLL bandwidth and peaking by controlling a precision jitter source and receiver.

- Automated PLL bandwidth and peaking measurements with report generation
- PCI Express PLL testing approved by PCI-SIG
- Flexible, can be customized for unique PLL applications
- Fast and accurate jitter spectrum/phase noise measurements on clock and data signals

For more information:
www.keysight.com/find/jtf

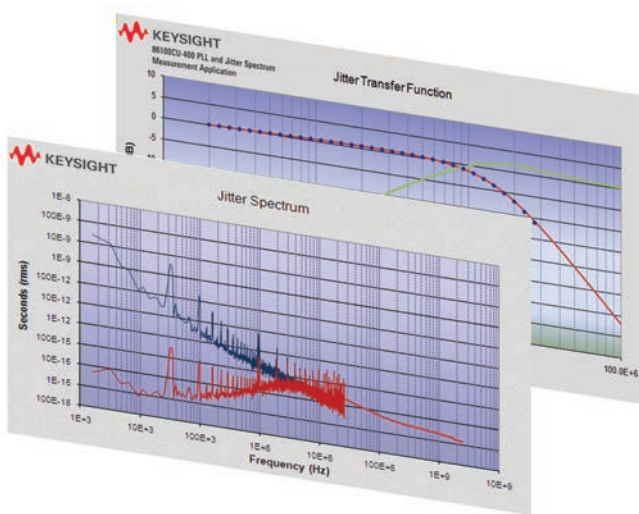

Advanced eye analysis, jitter on PRBS31 (86100DU-4012)

To ensure that digital communication systems approach error-free performance, data test patterns that emulate actual traffic are often used. Option 401 overcomes pattern length limitations of test equipment and performs:

- Jitter measurements on long patterns, including PRBS23, PRBS31, and live traffic
- Compliant jitter measurements such as:
 - TJ/RJ/DJ/J2/J9/DDPWS3

A Microsoft Excel-based workbook also provides precision mask testing using BER contour based masks.

For more information:
www.keysight.com/find/eye

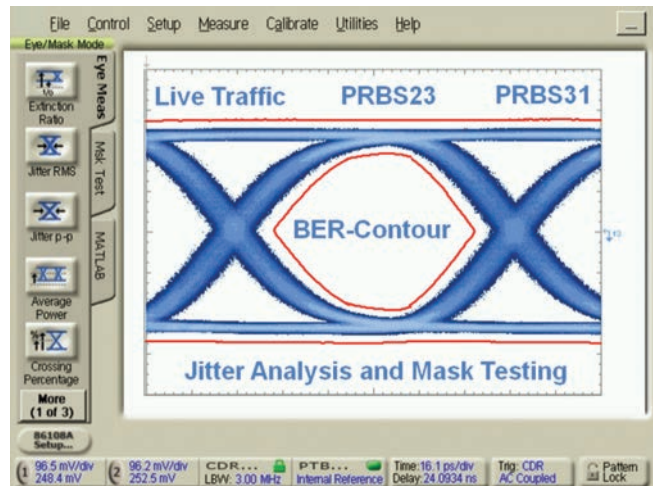

1. Requires an 83496A with Option UAB, 83496B, or 86108A/B module.

2. For best accuracy when measuring jitter on long patterns, it is recommended that 86100DU-401 be used in conjunction with 86100D-200.
 3. 3 DDPWS requires 86100D-200.

86100D DCA-X overview (continued)

Remote access software, connected or offline operation

(N1010A FlexDCA)

The FlexDCA user interface that comes standard on the 86100D DCA-X is also available as a standalone product. N1010A FlexDCA is a PC-based software application that

- Duplicates the integrated FlexDCA user interface for use from a PC (LAN control)
- Controls an 86100C or 86100D from the lab, office, or even from a remote site (great for troubleshooting)
- Provides offline analysis capability on saved waveforms or use the built-in waveform simulator
- Allows engineers to reproduce or simulate measurements and “what-if” simulations at a desk, without the need for hardware
- Uses N1010A and 86100D SW options when connected; uses N1010A SW options when operating offline
- Integrates with Keysight’s SystemVue electronic system-level (ESL) software. FlexDCA allows designers to visualize the simulated signals as if they were being displayed on an oscilloscope. Correlating simulated and measured waveforms becomes fast and efficient.

For more information:

www.keysight.com/find/flexdca

N1010A FlexDCA Connected (Hosted) vs Offline

Examples illustrating N1010A Flex DCA software option support model

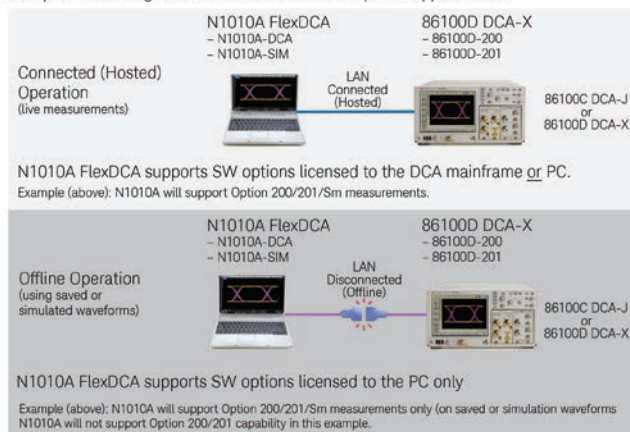

Module overview optical/electrical: 750-1650 nm

86105C - Engineered for highest flexibility

9 GHz optical/20 GHz electrical, 750 to 1650 nm
–SMF and MMF

The 86105C has the widest coverage of data rates with optical modulation bandwidth of 9 GHz and electrical bandwidth of 20 GHz. The outstanding sensitivity (to -21 dBm) makes the 86105C ideal for a wide range of design and manufacturing applications. Available filters cover all common data rates from 155 Mb/s through 11.3 Gb/s.

For more information:

www.keysight.com/find/86105C



86105D - Engineered for highest accuracy

20 or 34 GHz optical, 35 or 50 GHz electrical,
750-1650 nm, MMF and SMF

The 86105D is the premier solution for optical waveform analysis of high-speed signals using short or long wavelength technologies. Switchable compliance filters are available at all common rates from 8.5 to 14.025 Gb/s (16XFC). Option 281 provides 34 GHz optical bandwidth and reference receivers for 14, 25.78, and 28.05 Gb/s (excludes 8 to 11 Gb/s). Sensitivity to -12 dBm.

For more information:

www.keysight.com/find/86105D

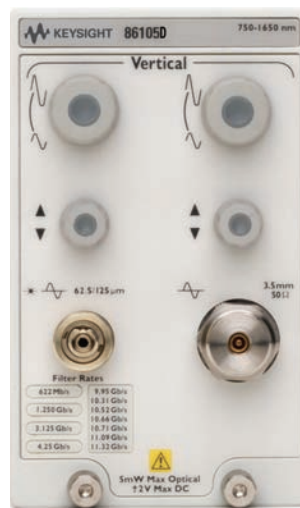

86115D- Engineered for highest productivity

20 GHz optical multi-port, 750-1650 nm, MMF
and SMF; designed for high-volume/parallel
optical transceiver test

For high volume manufacturing or testing of parallel optical systems, the 86115D can be used. The 86115D can be configured with two or four optical ports in a single plug-in module. Each port has specifications similar to the optical channel of the 86105D and covers all common rates from 8.5 to 14.025 Gb/s. (The 86115D does not have an electrical channel.) A multiple optical channel plug-in can offer significant savings compared to other configurations.

For more information:

www.keysight.com/find/86115D



Optical/electrical: 1000-1600 nm

86116C - Engineered for highest data rates 86116C-025

40 GHz optical/80 GHz electrical module, SMF

With more than 40 GHz optical bandwidth (1300-1620 nm), the 86116C-025 was engineered to address 100 Gb ethernet (4x 25 G) and 16X Fibre Channel (single mod variant) designs.

For more information:
www.keysight.com/find/86116C

86116C-041

65 GHz optical/80 GHz electrical module, SMF

With more than 70 GHz characteristic optical bandwidth and over 93 GHz characteristic electrical bandwidth, 86116C-041 has been optimized to accurately characterize high-speed telecom signals. It includes built-in compliance filters for 39.81, 41.25 and 43.02 Gb/s.

For more information:
www.keysight.com/find/86116C



Dual Electrical Modules



86108B - Engineered for highest precision and accuracy

Accuracy and ease-of-use for high-speed digital communications signals from 50 Mb/s to 32 Gb/s.

With industry-best residual jitter below 50 fs (typical), channel bandwidths to 50 GHz, and integrated clock recovery to 32 Gb/s, the 86108B allows users to be confident that they are seeing the true performance of their designs. Integration of several instrumentation blocks makes setups easy, improves measurement accuracy, and reduces equipment costs.

Option JSA provides jitter spectrum analysis and software clock recovery emulation for additional measurement insight and accuracy.

For more information:
www.keysight.com/find/86108B

86112A - Engineered for low noise applications

20 GHz dual channel electrical

The Keysight 86112A provides two accurate measurement channels with user-selectable bandwidths of 12.4 or 20 GHz. The lower bandwidth mode provides excellent oscilloscope noise performance for accurate measurement of small signals. The high bandwidth mode provides high-fidelity display and measurement of high-speed waveforms.

For more information:
www.keysight.com/find/A



Dual electrical modules

86117A - Engineered for highest waveform fidelity 50 GHz dual channel electrical

The Keysight 86117A provides designers and manufacturers with a cost-effective solution for testing 40 Gb/s electrical signals. The 86117A has 50 and 30 GHz bandwidth settings available on each electrical channel with 2.4 mm male electrical connectors.

For more information:
www.keysight.com/find/86117A



86118A - Engineered for closest proximity to DUT 70 GHz+ dual remote sampling head

The 86118A has two electrical channels, each housed in a compact remote sampling head, attached to the module with separate light weight cables. With over 80 GHz of bandwidth (typical), this module is intended for very high bit rate applications where signal fidelity is crucial. It is often paired with an 86107A Precision Timebase module required for extremely high-speed signal fidelity measurement applications. 86118A Option H01 provides hardware de-skew capability.

For more information:
www.keysight.com/find/86118A



N1045A1 - Engineered for testing DUTs with many channels

60 GHz+ dual/quad remote sampling head

The N1045A comes with two or four electrical channels per module², each housed in an ultra-compact remote sampling head. With over 65 GHz of bandwidth (typical) on up to 16 channels per mainframe, this module can greatly reduce capital costs and test time when characterizing a device having many ports. When extremely high-speed devices are being tested, it is often paired with an 86107A Precision Timebase module to obtain ultra-low timebase jitter of <200 fs rms. The N1045A includes hardware de-skew capability, and to minimize adapter use for a given application, users may choose between 1.85 mm male or female connectors³ for the remote heads.

For more information:
www.keysight.com/find/N1045A

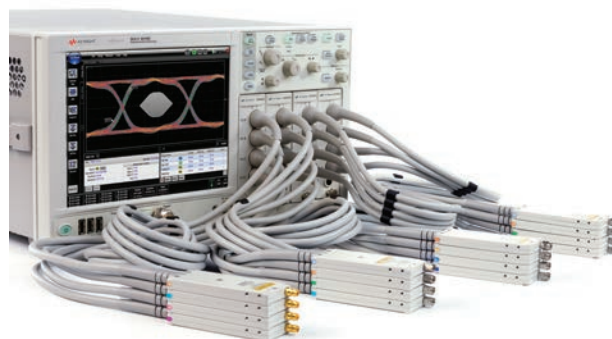

1. Module is compatible with 86100D DCA-X mainframe or later.
2. Upgradeable from 2 to 4 channels after purchase (return to Keysight upgrade)
3. Connector style is the same on all channels and is selected at the time of order.

Time domain reflectometry/transmission (TDR/TDT)

54754A - Engineered for novice and expert users¹ Differential & single-ended TDR/TDT module

The Keysight 54754A provides two 18 GHz channels that have built-in TDR step generators. With extremely well matched step responses, the two channels work in tandem to provide differential or common mode TDR stimulus/response, or may be used independently. Either channel works as a normal oscilloscope vertical system when the TDR/TDT step generators are turned off.

For more information:

www.keysight.com/find/54754A

N1055A - Engineered for high-performance TDR/TDT/S-parameter measurements² D35 or 50 GHz bandwidth, 2 or 4 channels

This is a fully-integrated TDR/TDT/S-parameter measurement system that provides calibrated results on up to 16 channels in real-time. The 2/4 port TDR/TDT remote heads can be configured with sampler bandwidth of 35 GHz (2.92 mm connector) or 50 GHz (1.85 mm connector), providing single-ended and differential measurement capability including True-Mode stimulus functionality. TDR step edge speeds are as fast as 8 ps. Calibrated scattering parameters (S-parameters) are generated in real-time using the 86100D-202. A special Keysight N4694A DC-67 GHz ECal module enables fast calibration and de-skew of the TDR/TDT system.

N1021B - Engineered for high-performance and durability

18 GHz differential TDR/TDT probe kit

The N1021B is an ergonomically designed high performance handheld probe to interface TDR/TDT modules such as the 54754A to printed circuit boards (PCBs) and components that lack common coaxial high-frequency connectors. The built-in wheel adjusts the pitch between the differential tips to make good contact to pads or access points. Hardened tips make the N1021B extremely durable.

For more information:

www.keysight.com/find/N1021B

1. Use with 86100A/B/C or 86100D-ETR mainframe otherwise an external trigger cable (such as P/N 5062-6690) is required.
2. Module is compatible with 86100D DCA-X mainframe or later.



Clock Recovery¹

83496B-100 - Engineered for flexibility and performance

Electrical clock recovery module with phase noise analysis capability

Increase eye-mask and jitter measurement accuracy with breakthrough performance in clock recovery circuitry. 83496B Option 100 provides instrument grade clock recovery covering any rate from 50 Mb/s-14.2 Gb/s. Adjustable loop bandwidth for standards compliant measurements. Jitter spectrum and phase noise analysis on clock and data signals is available with 86100CU-400 PLL and jitter spectrum analysis software.

For more information:

www.keysight.com/find/83496B



83496B-101 - Engineered for industry standard compliance

Optical/electrical clock recovery module with phase noise analysis capability

- 750-1330 nm MMF
- 1250-1650 nm SMF

Clock recovery performance matches that of the 83496B-100 (above). Option H05 adds internal electrical splitters providing data and databar signals to front panel SMA connectors.

For more information:

www.keysight.com/find/83496B



86108B - Engineered for highest precision and accuracy

Dual channel electrical module with integrated precision timebase and clock recovery to 32 Gb/s.

An integrated clock recovery circuit provides continuous data rate coverage from 50 Mb/s to 32 Gb/s. Adjustable loop bandwidth and peaking capability ensures compliant measurements. Analyze degraded signals such as “closed eyes” by triggering the 86100C/D DCA using the auxiliary CR input. Jitter spectrum analysis and software clock recovery emulation provides unique insight and complements Jitter Mode for enhanced measurement accuracy. For more information on the 86108B module, refer to the section on dual electrical modules.

For more information:

www.keysight.com/find/86108B



1. Use with 86100A/B/C or 86100D-ETR mainframe otherwise an external trigger cable (such as P/N 5062-6690) is required.

Precision timebase

86100D

The 86100D DCA-X wide-bandwidth oscilloscope uses a built-in timebase to acquire and display waveforms. While the standard timebase is sufficient for most applications, some high-speed measurements benefit from using the precision timebase capabilities of these modules. The precision timebase significantly reduces the scope's random jitter contribution and minimizes clock-data delay.

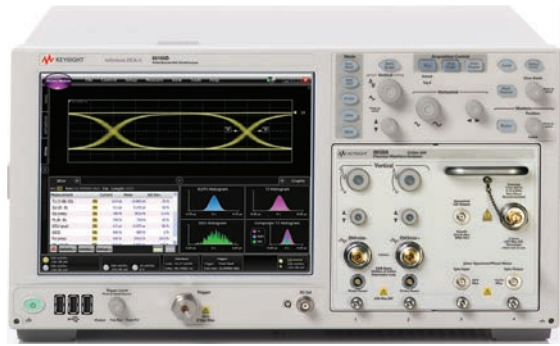

86107A

Precision timebase reference

Low oscilloscope jitter allows the true jitter performance of devices to be seen. The 86107A is used in tandem with any of the optical or electrical sampling modules to reduce mainframe trigger jitter below 100 fs. It is optionally configured to accept 10 G, 20 G, or 40 G input clock signals. (Oscilloscope jitter can be driven to even lower levels when using the 86108A/B precision waveform analyzer).

For more information:
www.keysight.com/find/86107A



86108A/B

Dual channel electrical with integrated precision timebase and clock recovery.

At less than 50 fs (typical), the 86108B provides the industry's lowest scope jitter. This means that the signal you see on the scope's display is not degraded by the scope itself. The 86108B can derive a clock from the test signal and internally feed the precision timebase section. Or an external timing reference can be provided to the precision timebase. Ultra-low jitter is achieved in either configuration.

For more information:
www.keysight.com/find/86108B



Probes

Active probes

The DCA Series oscilloscopes are designed to work with all Keysight InfiniMax probing systems. The InfiniMax system is comprised of a probe amplifier (choose your bandwidth) and probe head (choose the interface/tip for your application). Probe adapters, to interface the probe to your DCA module, are also available.



Probe adapters

- InfiniMax I active probes (1.5 to 7 GHz)
- requires N1022B Probe Adapter to interface to the DCA
- InfiniMax II active probes (10 to 13 GHz)
- requires N1022B Probe Adapter to interface to the DCA
- InfiniMax III active probes (16 to 30GHz)
- requires N5477A Probe Adapter to interface to the DCA



InfiniMax probes interface to DCA modules using a probe adapter.

- N1022B probe adapter is used for InfiniMax I and II systems
- N5477A probe adapter is used for InfiniMax III systems.



Probe power is supplied by the DCA module itself (a probe power connector(s) is available on some modules) or an 1143A external power supply.

InfiniMax III probe amplifiers

- N2803A 30 GHz probe amplifier
- N2802A 25 GHz probe amplifier
- N2801A 20 GHz probe amplifier
- N2800A 16 GHz probe amplifier

InfiniMax III probe heads

- N5439A InfiniMax III ZIF probe head
- N5441A InfiniMax III solder-in probe head
- N5444A InfiniMax III 2.92mm/3.5mm/SMA head
- N5445A InfiniMax III browser head
- N5448A InfiniMax III 2.92mm head flex cable



InfiniMax III probe adapters

- N5442A Precision BNC adapter
- N5443A Performance verification and deskew fixture
- N5449A High-impedance probe
- N5477A Sampling scope adapter (use this adapter to interface with DCA modules)
- N5449 High impedance adapter



Passive probes

- N1021B 18GHz Differential Probe Kit
- 54006A 6 GHz Passive Divider Probe Kit

Precision timebase

Dual channel electrical with integrated precision timebase and clock recovery.

The 86100D DCA-X wide-bandwidth oscilloscope uses a built-in timebase to acquire and display waveforms. While the standard timebase is sufficient for most applications, some high-speed measurements benefit from using the precision timebase capabilities of these modules. The precision timebase significantly reduces the scope's random jitter contribution and minimizes clock-data delay.

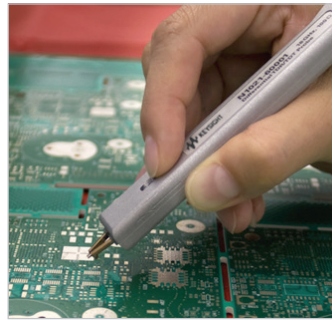

N1021B 18GHz Differential Probe Kit

Interfaces and accessories

Probes, adaptors and other interface kits

Other application-specific probe and interface kits are available from Keysight Technologies or its channel partners. See www.keysight.com or contact your local sales office for details.

N1027A-45A - Accessories kit for N1045x

- N1027A-45A N1045A accessory kit



N1024B TDR calibration kit

TDR/TDT accessories

- N1024B TDR calibration kit
- N9355CK01 DC coupled limiter
- 9300-1367 ESD wrist strap
- 9300-1484 ESD desk mat
- 9300-0980 ESD wrist strap ground cord
- N1027A-55A N1055A accessory kit
- N4694A-HMM/HFF/HMF ECal module DC to 67 GHz



N9355CK01 DC coupled limiter



N4694A-HMM ECal module for TDR/TDT calibration

Interfaces and accessories (continued)

www.keysight.com/find/parts

DCA accessories

- 86101-60017 module filler panel (1/4 bay width)
- 86101-60016 module filler panel (1/2 bay width)
- 0960-2929 USB keyboard (included with 86100D)
- 1150-7913 USB mouse (included with 86100D)
- 0950-4990 external DVD recorder multi format
- Kinesis Savant 2-action programmable foot switch P/N FS20A-USB-UL (<http://www.kinesis-ergo.com/>).
- 82351A PCIe-GPIB interface card
- N1027A-PT2 2.4 mm male-to-female phase trimmer
- N1027A-PT3 3.5 mm male-to-female phase trimmer
- N1000-40008 front impact cover
- 86100-60156 rack mount kit with handles
- 86100-60157 rack mount kit without handles



N1027A-PT3 3.5 mm phase adjuster



Kinesis USB foot switch



Module filler panels for 86100A/B/C/D

Optical connector interfaces

Note: All optical modules come standard with an FC/PC connector adapter interface (81000FI) installed on all optical ports

- 81000 AI Diamond HMS-10 connector
- 81000 FI FC/PC connector adapter
- 81000 SI DIN connector adapter
- 81000 VI ST connector adapter
- 81000 KI SC Connector adapter



Optical connector interfaces available for DCA optical modules

RF/Microwave accessories

- 11636B power divider, DC to 26.5 GHz, APC 3.5 mm
- 11636C power divider, DC to 50 GHz, 2.4 mm
- 11742A 45 MHz to 26.5 GHz DC blocking capacitor
- 11742A-K01 50 GHz DC blocking capacitor
- 8490D-020 2.4 mm 20 dB attenuator
- 8493C-020 3.5 mm 20 dB attenuator
- 11900B 2.4 mm (f-f) adapter
- 11901B 2.4 mm (f) to 3.5 mm (f) adapter
- 11901C 2.4 mm (m) to 3.5 mm (f) adapter
- 11901D 2.4 mm (f) to 3.5 mm (m) adapter
- 5061-5311 3.5 mm (f-f) adapter
- 1250-1666 SMA (f-f) adapter feedthru



11742A DC blocking capacitor



8490D attenuator



11636B DC to 26.5 GHz power divider



11636C DC to 50 GHz power divider

Complementary products

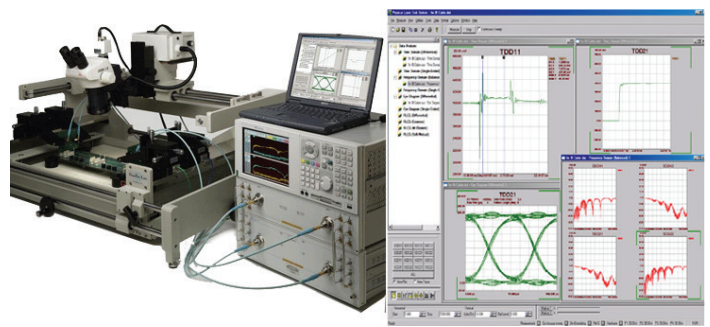
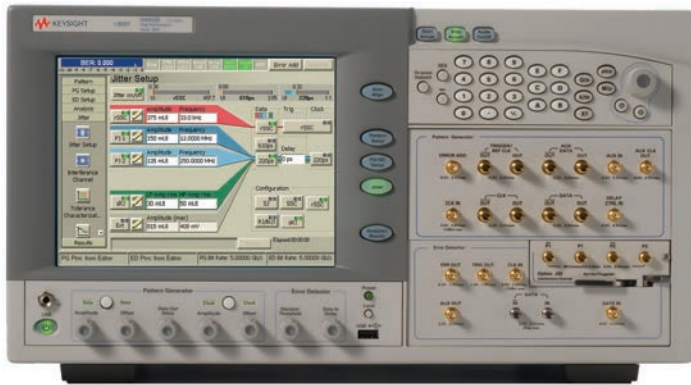

The N4903B J-BERT, in combination with the 86100D DCA-X, provides complete insight into the physical layer performance of your design.

The N1930B physical layer test system (PLTS) software provides confidence in your design through complete characterization and behavior model extraction of your device under test (DUT). It supports both TDR and VNA platforms from Keysight Technologies.

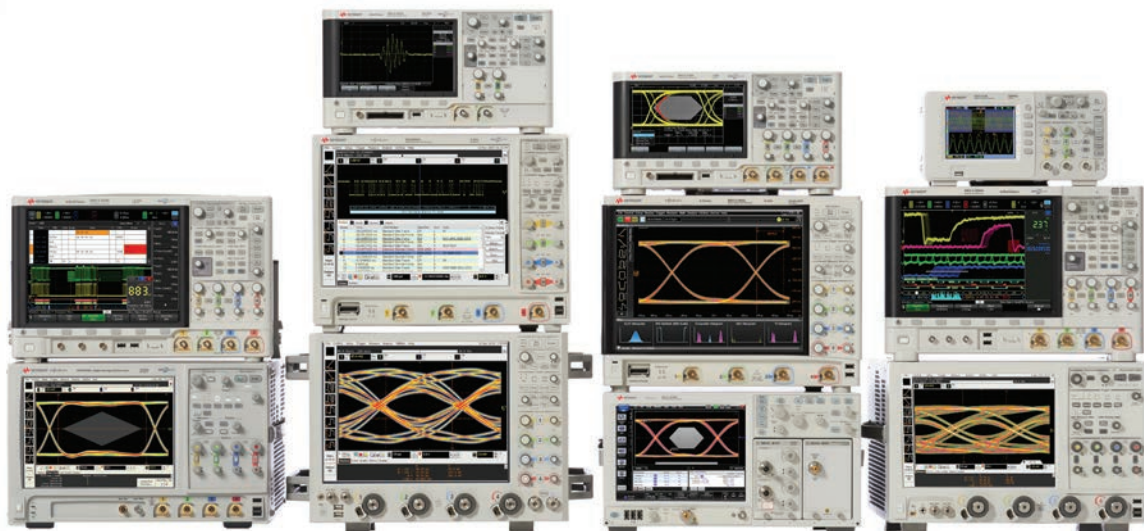

Keysight Oscilloscopes

Multiple form factors from 20 MHz to >90 GHz | Industry leading specs | Powerful applications

www.keysight.com/find/86100D



This information is subject to change without notice.
© Keysight Technologies, 2014 - 2017
Published in USA, December 5, 2017
5990-5822EN
www.keysight.com