

USB Power Sensor MA24106A

True-RMS, 50 MHz to 6 GHz

- Economical Alternative to Traditional Benchtop Meters
- True RMS Measurements Over a 63 dB Dynamic Range
- High Damage Power Levels and ESD Protection
- No Need for a Reference Calibrator
- Light Weight and Easy to Use



Handy, Highly Accurate and Reliable USB Sensor
for your RF Power Measurement Needs

Accurate Enough for Lab, Fast Enough for Manufacturing and Rugged Enough for Field Applications

Features

- True RMS detection over a 63 dB dynamic range enables accurate CW and modulated power measurements
- Ready for use in a wide variety of applications, including installation and maintenance of base stations, testing of 3G and 4G products, cell phones and general purpose RF devices
- High damage power levels and ESD protection provides ruggedness and reliability
- Low current consumption (100 mA) preserves laptop battery life
- Eliminating the need for a reference calibrator reduces test time and handling in production
- Light weight, economical and easy to use with a desktop or laptop PC
- One year calibration cycle and worldwide service centers ensure reduced downtime
- Compatible with PowerXpert™, Spectrum Master™, VNA Master™, BTS Master™, Site Master (S3xxE), Cell Master™ (MT8212E), and Economy Spectrum Analyzer (MS271xB)



N connector designed for use with a torque wrench ensures repeatable connections

Sturdy aluminum body with ergonomic design for better grip and feel



Two-color LED reports functional status of the sensor

USB Mini-B Port for PC connectivity

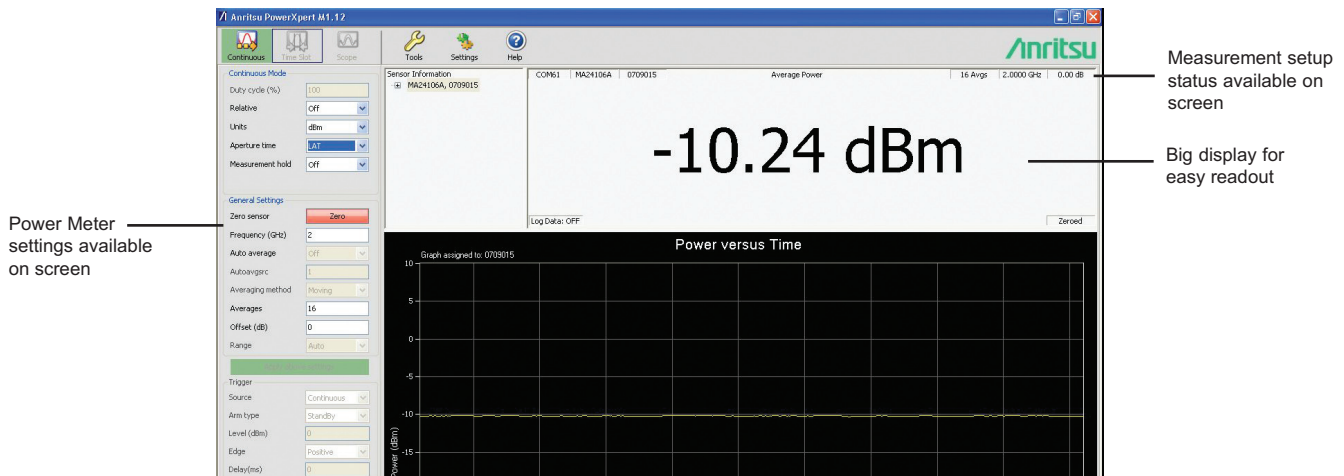

MA24106A Architecture

The MA24106A power sensor is a highly accurate instrument that communicates with a PC using the Universal Serial Bus interface (USB). Its measurement capability mimics a traditional thermal (thermo-electric) power sensor, but has a wider dynamic range. Therefore, the MA24106A is ideal for measuring average power of CW, multi-tone, and modulated RF waveforms such as 3G, 4G, and OFDM. It measures true RMS power regardless of the type or bandwidth of the input signal.

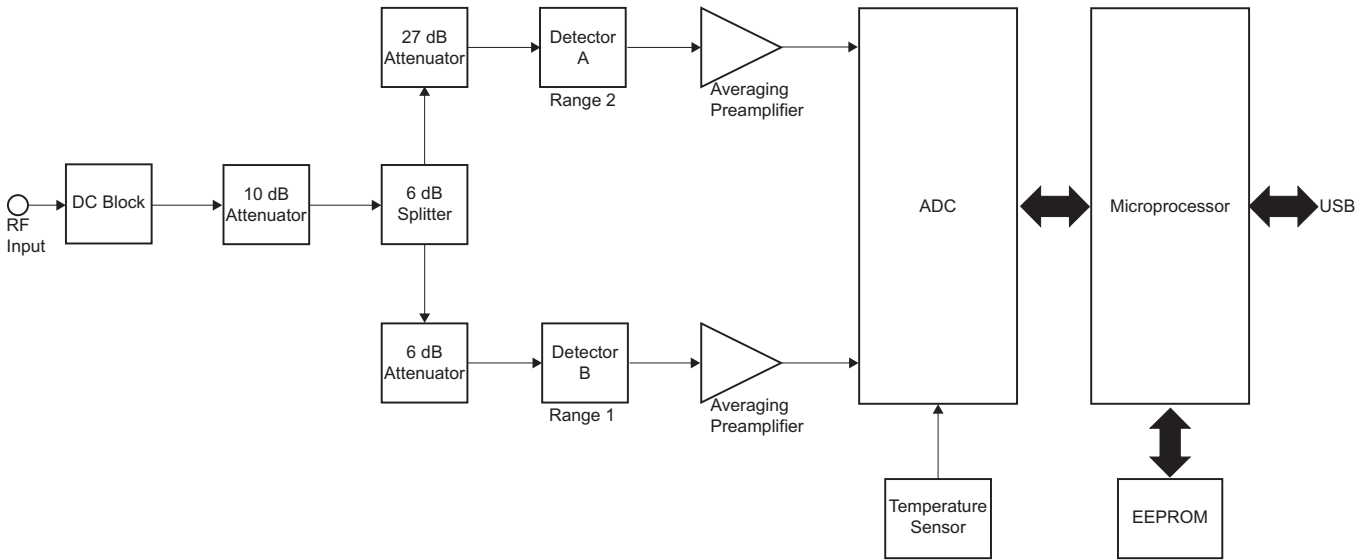

MA24106A Block Diagram

The sensor employs a “dual-path” architecture to achieve 63 dB of dynamic range. Highly accurate modulation measurements are facilitated by keeping the diode detectors in the “square law region” and by choosing the output of the appropriate detector path. A built-in attenuator provides excellent SWR performance thus minimizing mismatch error. The presence of a micro-controller along with signal conditioning circuitry, ADC, and power supply in the sensor makes it a complete miniature power meter. The PowerXpert application for personal computers running Microsoft® Windows® can be used to control and operate the sensor providing the user with a familiar power meter interface with advanced features.

Rugged for Field Use

The MA24106A power sensor provides lab performance accuracy in a rugged and portable field solution. Measurement accuracy over a wide temperature range is maintained by internally stored calibration factors with temperature compensation, thus making it perfect for base station installation and maintenance applications. Field and service technicians will appreciate the small size and light weight as they can carry it in their shirt pocket or laptop case. A very easy to use PC application with a large display makes operation straightforward for users with limited training. The high damage level (+33 dBm) and ESD protection (3.3 kV) provides ruggedness to this high performance sensor. Since the MA24106A is a low power device, laptop battery life is preserved.

Fast and Flexible for Production

The MA24106A facilitates lab quality measurements on the production floor for a fraction of the cost of traditional power meters. Valuable rack space is saved since the sensor is connected directly to a PC, eliminating the need for a bench top power meter. Sensor speed is optimized for best accuracy and noise performance making it suitable for a wide variety of ATE applications. Multiple sensors can be connected and remotely controlled via a single PC allowing flexibility to match specific measurement needs. The reference calibrator typically needed by power meters has been eliminated, minimizing test station complexity, sensor handling and reducing test times.

The offset table provides the ability to correct for the frequency response of RF devices present between the sensor and the DUT, thus providing better accuracy than just using a fixed offset. A simple interface allows entry of different offset values versus frequency. An unlimited number of offset tables can be stored on a PC's hard disk and easily recalled. The offset table employs linear interpolation to estimate offset correction for frequencies between user specified entries.

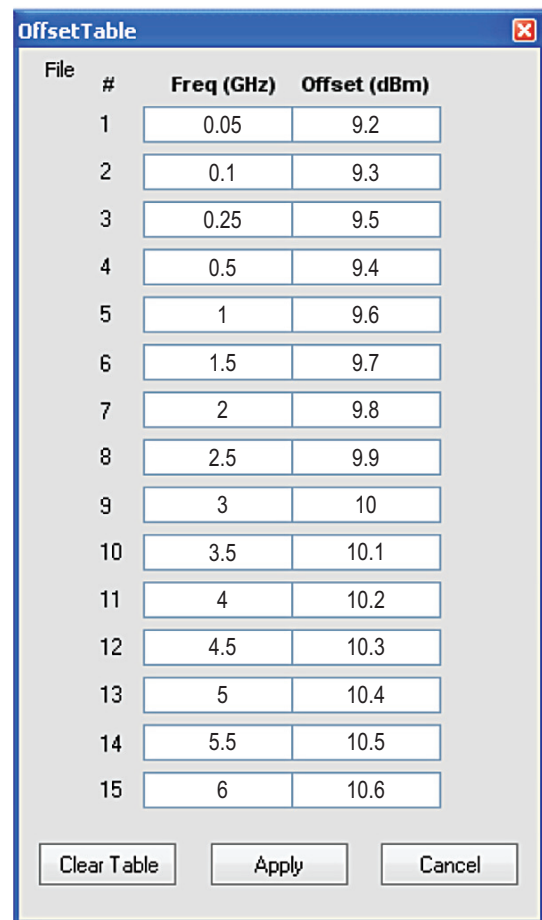

File #	Freq (GHz)	Offset (dBm)
1	0.05	9.2
2	0.1	9.3
3	0.25	9.5
4	0.5	9.4
5	1	9.6
6	1.5	9.7
7	2	9.8
8	2.5	9.9
9	3	10
10	3.5	10.1
11	4	10.2
12	4.5	10.3
13	5	10.4
14	5.5	10.5
15	6	10.6

Compensate for frequency response of RF devices with offset table. Values are easily saved to and recalled from the PC's hard disk.

High Accuracy for R&D Use

The MA24106A is an ideal general purpose R&D tool due to its low cost, ability to measure a variety of RF waveforms, wide dynamic range, and power accuracy. Its compact size saves space by replacing traditional bench top instruments. True RMS power measurements of modulated signals are made effortlessly with no limits on modulation bandwidths. Accuracy is assured because the calibration data is stored directly in the sensor and all necessary corrections (frequency and temperature) are done internally. The standards used to calibrate this sensor are directly traceable to NIST and periodic calibrations are supported by Anritsu's service centers worldwide.

The PowerXpert software provides an intuitive interface to control the sensor. It has advanced features such as average power versus time display and data logging, plus a customizable offset table enabling flexible data capture and accurate measurements versus frequency.

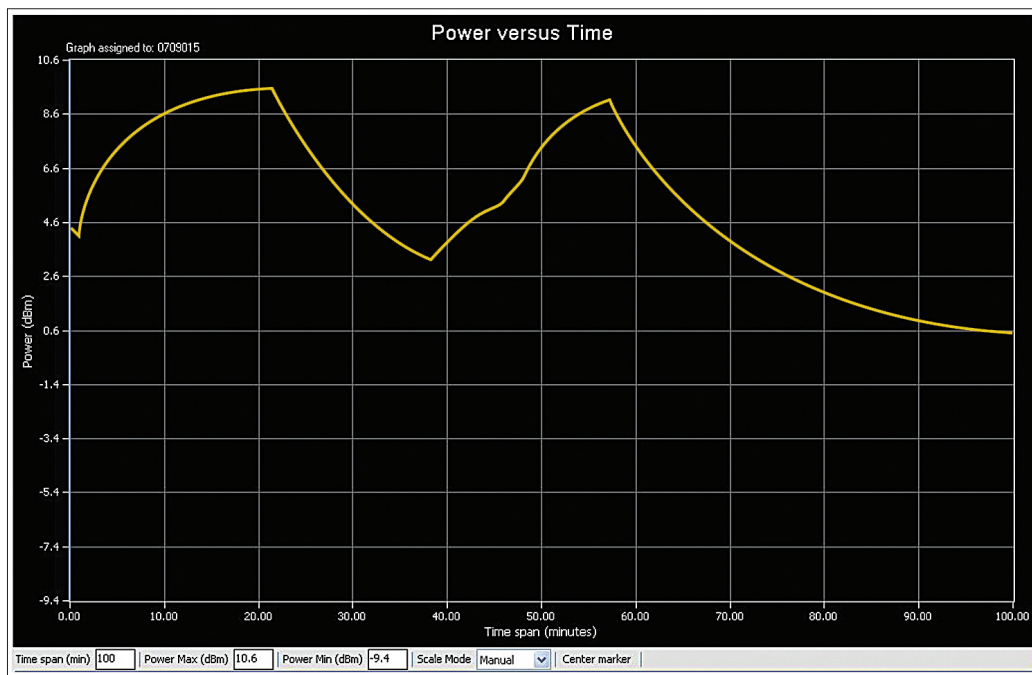

Power versus Time graph shows the effect of turning on and off the cooling fan of a 2 GHz power amplifier

The power graph plots power with respect to time. It is useful for drift testing, circuit tuning, or circuit monitoring as external stimuli are changed. The graph is continuously updated in real time at ten measurements per second.

Data logging is also available for recording power versus time to a hard disc or other storage media. This is useful for long term drift studies, environmental testing, and trend analysis. A user defined logging interval allows acquisition speed to match test requirements. Data are stored as a comma separated value (.csv) that can be opened in Microsoft® Excel® facilitating custom analysis.

Specifications

Sensor

Frequency range	50 MHz to 6 GHz
Dynamic range	-40 dBm to +23 dBm
Input return loss	>26 dB (50 MHz to <2 GHz) >20 dB, (2 GHz to 6 GHz)
Measurement ranges	Range 1, -40 dBm to -5 dBm Range 2, -5 dBm to +23 dBm
Signal channel bandwidth	100 Hz, typical

Measurement Uncertainty

Linearity	±0.13 dB (power level <+18 dBm) ±0.18 dB (power level ≥+18 dBm)
Calibration factor ⁽¹⁾	±0.06 dB
Noise ⁽²⁾	<2.5 nW (-40 dBm to -5 dBm) <0.6 μW (-5 dBm to +23 dBm)
Zero set	<10 nW (-40 dBm to -5 dBm) <1.7 μW (-5 dBm to +23 dBm)
Zero drift ⁽³⁾	<3.0 nW (-40 dBm to -5 dBm) <0.5 μW (-5 dBm to +23 dBm)
Temperature compensation ⁽⁴⁾ (0° C to 50° C)	±0.06 dB
Effect of digital modulation ⁽⁴⁾	±0.02 dB (power level <+18 dBm) ±0.10 dB (power level ≥+18 dBm)

System

Measurand	True-RMS/Average power
Measurement resolution	0.01 dB
Offset range	±100 dB
Averaging range	1 to 256
Measurement speed ⁽⁵⁾	10 measurement per second, typical
Range	Auto ranging between Range 1 and Range 2
Interface	USB 2.0
Host operating system (PowerXpert application compatibility)	Microsoft® Windows 7, Windows® Vista, Windows XP, and Windows 2000

General

Current (via host USB) ⁽⁶⁾	100 mA typical at 5V
Maximum DC voltage at RF port	±25 V
Maximum CW power	+33 dBm
Size (W x H x D) ⁽⁷⁾	56 mm x 30 mm x 85 mm typical (2.2 in. x 1.18 in. x 3.35 in.)
Weight	180 grams typical (6.4 oz.)

Environmental⁽⁸⁾

Operating Temperature Range	0° C to +55° C
Storage Temperature Range	-51° C to +71° C
Humidity	45% relative humidity at 55° C (non-condensing) 75% relative humidity at 40° C (non-condensing) 95% relative humidity at 30° C (non-condensing)
Shock	30 g half-sine, 11 ms duration
Vibration	Sinusoidal: 5-55 Hz, 3 g max. Random: 10-500 Hz, Power Spectral Density 0.03 g/Hz
EMC	Meets EN 61326, EN 55011
Safety	Meets EN 61010-1

Notes:

All specs are applicable after twenty minutes warm-up at room temperature unless specified otherwise.

⁽¹⁾ Expanded uncertainty with K=2 for absolute power measurements on CW signal at 0 dBm calibration level from 50 MHz to 6 GHz.

⁽²⁾ Expanded uncertainty with K=2 after zero operation when measured with 128 averages for 5 minutes.

In high aperture time mode, noise is 1.3 nW and 0.3 μW in range 1 and range 2 respectively.

⁽³⁾ After one hour warm-up and zero operation. Measured with 128 averages for one hour keeping the temperature within ±1° C.

⁽⁴⁾ Measurement error with reference to a CW signal of equal power and frequency at 25° C.

⁽⁵⁾ One measurement per second, typical in high aperture time mode.

⁽⁶⁾ 150 mA max.

⁽⁷⁾ Not including N connector.

⁽⁸⁾ Tests were performed per MIL-PRF-28800F (Class 2)

Ordering Information

MA24106A USB Power Sensor

Included Accessories

2000-1566-R 1.8 meters USB A to Mini-B cable
2300-526 Product CD - Anritsu PowerXpert and USB power sensors
10585-00021 Quick Start Guide

Available Options

MA24106A-097 Option 97, Accredited Calibration to ISO17025 and ANSI/NCSL Z540. Test report and uncertainty data included.
MA24106A-098 Option 98, Standard calibration to ISO17025 and ANSI/NCSL Z540.
MA24106A-099 Option 99, Premium calibration to ISO17025 and ANSI/NCSL Z540. Test report and uncertainty data included.

Optional Accessories

Cables

2000-1593-R 3 meters USB A to Mini-B cable
2000-1594-R 5 meters USB A to Mini-B cable

Calibrated Torque Wrenches

01-200 Calibrated torque wrench for N connector
01-204 Calibrated torque wrench for K and V connectors

Power Attenuators

3-1010-123 N(m) to N(f), DC to 8.5 GHz, 30 dB, 50 W, 50 Ω
3-1010-124 N(m) to N(f), DC to 8.5 GHz, 40 dB, 100 W, 50 Ω
3-1010-122 N(m) to N(f), DC to 12.4 GHz, 20 dB, 5 W, 50 Ω
42N50-20 N(m) to N(f), DC to 18 GHz, 20 dB, 5 W, 50 Ω
42N50-30 N(m) to N(f), DC to 18 GHz, 30 dB, 50 W, 50 Ω

Precision Coaxial Adapters

510-90 N(m) to 7/16 DIN(f), DC to 3.3 GHz
510-91 N(f) to 7/16 DIN(f), DC to 3.3 GHz
510-92 N(m) to 7/16 DIN(m), DC to 3.3 GHz
510-93 N(f) to 7/16 DIN(m), DC to 3.3 GHz
33N50B N(f) to N(f), DC to 18 GHz
33N50B N(m) to N(f), DC to 18 GHz
33N50B N(m) to N(m), DC to 18 GHz
34AN50 GPC-7 to N(m), DC to 18 GHz
34ANF50 GPC-7 to N(f), DC to 18 GHz
34NFK50 N(f) to K(m), DC to 18 GHz
34NFKF50 N(f) to K(f), DC to 18 GHz
34NK50 N(m) to K(m), DC to 18 GHz
34NKF50 N(m) to K(f), DC to 18 GHz



Anritsu Corporation

5-1-1 Onna, Atsugi-shi, Kanagawa, 243-8555 Japan
Phone: +81-46-223-1111
Fax: +81-46-296-1264

• U.S.A.

Anritsu Company

1155 East Collins Boulevard, Suite 100,
Richardson, Texas 75081 U.S.A.
Toll Free: 1-800-ANRITSU (267-4878)
Phone: +1-972-644-1777
Fax: +1-972-671-1877

• Canada

Anritsu Electronics Ltd.

700 Silver Seven Road, Suite 120, Kanata,
Ontario K2V 1C3, Canada
Phone: +1-613-591-2003
Fax: +1-613-591-1006

• Brazil

Anritsu Eletrônica Ltda.

Praca Amadeu Amaral, 27-1 Andar
01327-010 - Paraiso, São Paulo, Brazil
Phone: +55-11-3283-2511
Fax: +55-11-3288-6940

• Mexico

Anritsu Company, S.A. de C.V.

Av. Ejército Nacional No. 579 Piso 9, Col. Granada
11520 México, D.F., México
Phone: +52-55-1101-2370
Fax: +52-55-5254-3147

• U.K.

Anritsu EMEA Ltd.

200 Capability Green, Luton, Bedfordshire LU1 3LU, U.K.
Phone: +44-1582-433280
Fax: +44-1582-731303

• France

Anritsu S.A.

16/18 Avenue du Québec-SILIC 720
91961 COURTABOEUF CEDEX, France
Phone: +33-1-60-92-15-50
Fax: +33-1-64-46-10-65

• Germany

Anritsu GmbH

Nemetschek Haus, Konrad-Zuse-Platz 1
81829 München, Germany
Phone: +49 (0) 89 442308-0
Fax: +49 (0) 89 442308-55

• Italy

Anritsu S.p.A.

Via Elio Vittorini, 129, 00144 Roma, Italy
Phone: +39-06-509-9711
Fax: +39-06-502-2425

• Sweden

Anritsu AB

Borgafjordsgatan 13, 164 40 Kista, Sweden
Phone: +46-8-534-707-00
Fax: +46-8-534-707-30

• Finland

Anritsu AB

Teknobulevardi 3-5, FI-01530 Vantaa, Finland
Phone: +358-20-741-8100
Fax: +358-20-741-8111

• Denmark

Anritsu A/S

Kirkebjerg Allé 90 DK-2605 Brøndby, Denmark
Phone: +45-72112200
Fax: +45-72112210

• Spain

Anritsu EMEA Ltd.

Oficina de Representación en España

Edificio Veganova
Avda de la Vega, nº 1 (edf 8, pl1, of 8)
28108 ALCOBENDAS - Madrid, Spain
Phone: +34-914905761
Fax: +34-914905762

• Russia

Anritsu EMEA Ltd.

Representation Office in Russia

Tverskaya str. 16/2, bld. 1, 7th floor.
Russia, 125009, Moscow
Phone: +7-495-363-1694
Fax: +7-495-935-8962

• United Arab Emirates

Anritsu EMEA Ltd.

Dubai Liaison Office

P O Box 500413 - Dubai Internet City
Al Thuraya Building, Tower 1, Suite 701, 7th Floor
Dubai, United Arab Emirates
Phone: +971-4-3670352
Fax: +971-4-3688460

• Singapore

Anritsu Pte. Ltd.

60 Alexandra Terrace, #02-08, The Comtech (Lobby A)
Singapore 118502
Phone: +65-6282-2400
Fax: +65-6282-2533

• India

Anritsu Pte. Ltd.

India Liaison Office

Unit No.S-3, Second Floor, Esteem Red Cross Bhavan,
No.26, Race Course Road, Bangalore 560 001 India
Phone: +91-80-32944707
Fax: +91-80-22356648

• P. R. China (Hong Kong)

Anritsu Company Ltd.

Units 4 & 5, 28th Floor, Greenfield Tower, Concordia Plaza,
No. 1 Science Museum Road, Tsim Sha Tsui East,
Kowloon, Hong Kong, P.R. China
Phone: +852-2301-4980
Fax: +852-2301-3545

• P. R. China (Beijing)

Anritsu Company Ltd.

Beijing Representative Office

Room 1515, Beijing Fortune Building,
No. 5, Dong-San-Huan Bei Road,
Chao-Yang District, Beijing 100004, P.R. China
Phone: +86-10-6590-9230
Fax: +86-10-6590-9235

• Korea

Anritsu Corporation, Ltd.

8F Hyunju Bldg. 832-41, Yeoksam-Dong,
Kangnam-ku, Seoul, 135-080, Korea
Phone: +82-2-553-6603
Fax: +82-2-553-6604

• Australia

Anritsu Pty Ltd.

Unit 21/270 Ferntree Gully Road, Notting Hill
Victoria, 3168, Australia
Phone: +61-3-9558-8177
Fax: +61-3-9558-8255

• Taiwan

Anritsu Company Inc.

7F, No. 316, Sec. 1, Neihu Rd., Taipei 114, Taiwan
Phone: +886-2-8751-1816
Fax: +886-2-8751-1817

Please Contact:

