

# **DL750/DL750P** **ScopeCorder**

# U S E R ' S M A N U A L

---

***GiGAZoom***  
ENGINE™

# Contents

## User's Manual Part 1

Manuals That Come with the DL750/DL750P .....	Part 1:iii
Checking the Contents of the Package .....	Part 1:v
Safety Precautions .....	Part 1:ix
Conventions Used in This Manual .....	Part 1:xii
Functions Described in This Manual and the DL750/DL750P Version .....	Part 1:xiii
Flow of Operation .....	Part 1:xv

## Chapter 1 Names and Functions of Parts

1.1 Top Panel, Front Panel, Right Side Panel, and Left Side Panel .....	1-1
1.2 Panel Keys and Knobs .....	1-7
1.3 Display Screens .....	1-10

## Chapter 2 Explanation of Functions

2.1 System Configuration/Block Diagram .....	2-1
2.2 Setting the Horizontal and Vertical Axes .....	2-3
Horizontal Axis, Vertical Axis (Voltage Axis), Moving the Vertical Position of Waveforms, Offset Value, Zooming in or out of the Vertical Axis (Expand/Reduce), Input Coupling, Probe Type, Bandwidth Limit, Linear Scaling, Inverted Display, Pulse/Rotate Function, RMS Measurement, Temperature Measurement, Strain Measurement, Acceleration Measurement, Frequency (Number of Rotations, Period, Duty Cycle, Power Supply Frequency, Pulse Width, Pulse Integration, and Velocity) Measurement, Logic Waveforms, Event Waveforms	
2.3 Setting the Trigger .....	2-20
Trigger Type (Input Signal Trigger, External Trigger, Line Trigger, Timer Trigger, A -> B(N) Trigger, A Delay B Trigger, Edge on A Trigger, OR Trigger, B > Time Trigger, B < Time Trigger, and B TimeOut Trigger, Period Trigger, Window Trigger, Wave Window Trigger), Trigger Mode, Trigger Delay, Trigger Position, Trigger Source, Trigger Slope, and Trigger Level, Trigger Hysteresis, Trigger Hold-off, Action-on-Trigger, Manual Trigger	
2.4 Setting Waveform Acquisition Conditions and Display Conditions .....	2-31
Record Length, Acquisition Mode(Normal Mode, Averaging Mode, Envelope Mode, Box Average Mode), Sequential Store Function, History Memory Function, Dual Capture Function, Realtime Recording to the Internal Hard Disk, Action-on-Stop, Voice Memo Function, Backing Up the Acquisition Memory, Display Format and Waveform Mapping, Display Interpolation, All-Point Display and Decimation Display, Graticule , Accumulated Display, Extra Window, Scale Values, Waveform Labels, Level Indicators and Numeric Values, Translucent Mode Display , Displaying the Channel Information and Expanding the Waveform Display Area, X-Y Waveform Display, Zooming in on the Waveform Horizontally , Snapshot, Clearing Traces	
2.5 Recording in Recorder Mode (Realtime Recording) (DL750P Only) .....	2-43
Chart Recorder Mode, X-Y Recorder Mode, Reprinting on the Built-in Printer (Only during T-Y Recording), Creating a PDF File of the Reprint Image (Only during T-Y Recording)	
2.6 Waveform Computation .....	2-47
Addition, Subtraction, Multiplication, and Division, Binary Computation, Power Spectrum Display, Phase Shift (Phase Mode), User-Defined Computation, Scaling of Computed Waveforms, DSP Channels	
2.7 Waveform Analysis/Search .....	2-53
Displaying History Waveforms, History Search Function, Search and Zoom Function, Cursor Measurement, Automated Measurement of Waveform Parameters, Statistical Processing, GO/NO-GO Determination	
2.8 Communications .....	2-59
Command (GP-IB, Serial (RS-232), USB and Ethernet Communications), Saving/Loading Data to a Network Drive (FTP Client Function), Printing Screen Image Data on a Network Printer, Transmitting E-mail Messages (SMTP Client Function), Accessing the DL750/DL750P from a PC or Workstation (FTP Server Function), Web Server Function	
2.9 Other Useful Functions .....	2-61
Entering Values Directly from the NUM Keys, Entering Values and Strings from a USB Keyboard, Operations Using a USB Mouse, Initialization, Auto Setup, Printing the Screen Image Data, Saving and Loading Various Data on the Storage Medium, Creating a PDF File of the Print Image (DL750P Only), Voice Comment Function, Operating the instrument Using a Free Software Program, Connecting the DL750/DL750P and the PC via the SCSI	

<b>Chapter 3</b>	<b>Making Preparations for Measurements</b>	
	3.1 Handling Precautions .....	3-1
	3.2 Installing the Instrument .....	3-3
△	3.3 Installing Input Modules .....	3-5
△	3.4 Connecting the Power Supply and Turning the Power Switch ON/OFF .....	3-8
	3.5 Setting the Date and Time .....	3-13
△	3.6 Connecting Probes .....	3-15
△	3.7 Compensating the Probe (Phase Correction) .....	3-21
△	3.8 Connecting Measuring Leads .....	3-23
△	3.9 Connecting Thermocouples .....	3-24
△	3.10 Connecting a Bridge Head (Only on Strain Modules) .....	3-25
△	3.11 Connecting Logic Probes .....	3-28
△	3.12 Connecting Acceleration Sensors .....	3-30
△	3.13 Connecting Sensors to the Frequency Module .....	3-32
△	3.14 Connecting the Earphone Microphone with a PUSH Switch and Connecting the Speaker .....	3-33
<b>Chapter 4</b>	<b>Common Operations</b>	
	4.1 Operations and Functions of Keys and the Jog Shuttle .....	4-1
	4.2 Entering Values and Strings .....	4-3
	4.3 USB Keyboard/USB Mouse .....	4-7
	4.4 Initializing Settings .....	4-16
	4.5 Performing Auto Setup .....	4-18
	4.6 Performing Calibration .....	4-21
	4.7 Using the Help Function .....	4-22
<b>Chapter 5</b>	<b>Horizontal and Vertical Axes</b>	
	<b>Voltage Measurement (On the 701250, 701251, 701255, 701260, 701261, 701262, 701265, or 701275)</b>	
	5.1 Turning Channels ON/OFF .....	5-1
	5.2 Setting T/div .....	5-2
	5.3 Setting V/div .....	5-3
	5.4 Setting the Vertical Position of Waveforms .....	5-5
	5.5 Setting the Input Coupling .....	5-7
	5.6 Setting the Probe Type .....	5-9
	5.7 Setting the Bandwidth .....	5-10
	5.8 Zooming Vertically by Setting the Zoom Rate .....	5-12
	5.9 Zooming Vertically According to the Upper and Lower Limits of the Display Range .....	5-14
	5.10 Setting the Offset Value .....	5-16
	5.11 Using the Linear Scaling Function (AX+B, P1-P2) .....	5-18
	5.12 Inverting Waveforms .....	5-21
	5.13 Displaying the All Channel Setup Menu .....	5-22
	5.14 Setting the Time Base (Internal Clock/External Clock) .....	5-25
	5.15 Observing RMS Values .....	5-28

**Temperature Measurement (On the 701261, 701262, or 701265)**

5.1	Turning Channels ON/OFF .....	5-1
5.2	Setting T/div .....	5-2
5.5	Setting the Input Coupling .....	5-7
5.7	Setting the Bandwidth .....	5-10
5.13	Displaying the All Channel Setup Menu .....	5-22
5.14	Setting the Time Base (Internal Clock/External Clock) .....	5-25
5.16	Setting the Temperature Measurement .....	5-29

**Strain Measurement (On the 701270, or 701271)**

5.1	Turning Channels ON/OFF .....	5-1
5.2	Setting T/div .....	5-2
5.7	Setting the Bandwidth .....	5-10
5.11	Using the Linear Scaling Function (AX+B, P1-P2) .....	5-18
5.12	Inverting Waveforms .....	5-21
5.13	Displaying the All Channel Setup Menu .....	5-22
5.14	Setting the Time Base (Internal Clock/External Clock) .....	5-25
5.17	Setting the Strain Measurement .....	5-31

**Acceleration Measurement (On the 701275)**

5.1	Turning Channels ON/OFF .....	5-1
5.2	Setting T/div .....	5-2
5.4	Setting the Vertical Position of Waveforms .....	5-5
5.5	Setting the Input Coupling .....	5-7
5.7	Setting the Bandwidth .....	5-10
5.8	Zooming Vertically by Setting the Zoom Rate .....	5-12
5.9	Zooming Vertically According to the Upper and Lower Limits of the Display Range .....	5-14
5.13	Displaying the All Channel Setup Menu .....	5-22
5.14	Setting the Time Base (Internal Clock/External Clock) .....	5-25
5.18	Setting the Acceleration Measurement .....	5-38

**Frequency (Number of Rotations, Period, Duty Cycle, Power Supply Frequency, Pulse Width, Pulse Integration, and Velocity) Measurement (On the 701280)**

5.1	Turning Channels ON/OFF .....	5-1
5.2	Setting T/div .....	5-2
5.4	Setting the Vertical Position of Waveforms .....	5-5
5.8	Zooming Vertically by Setting the Zoom Rate .....	5-12
5.9	Zooming Vertically According to the Upper and Lower Limits of the Display Range .....	5-14
5.10	Setting the Offset Value .....	5-16
5.11	Using the Linear Scaling Function (AX+B, P1-P2) .....	5-18
5.13	Displaying the All Channel Setup Menu .....	5-22
5.14	Setting the Time Base (Internal Clock/External Clock) .....	5-25
5.19	Setting the Frequency (Number of Rotations, Period, Duty Cycle, Power Supply Frequency, Pulse Width, Pulse Integration, and Velocity) Measurement .....	5-40

**Logic Waveform Measurement**

5.1	Turning Channels ON/OFF .....	5-1
5.4	Setting the Vertical Position of Waveforms .....	5-5
5.8	Zooming Vertically by Setting the Zoom Rate .....	5-12
5.20	Setting Logic Waveforms .....	5-55



**Event Observation**

5.1	Turning Channels ON/OFF .....	5-1
5.4	Setting the Vertical Position of Waveforms .....	5-5
5.8	Zooming Vertically by Setting the Zoom Rate .....	5-12
5.21	Setting Event Waveforms .....	5-57

**Chapter 6**

**Triggering**

6.1	Setting the Trigger Mode .....	6-1
6.2	Setting the Trigger Position .....	6-3
6.3	Setting the Trigger Delay .....	6-5
6.4	Setting the Hold Off Time .....	6-6
6.5	Setting the Edge Trigger (SIMPLE) .....	6-8
6.6	Setting the External Trigger (SIMPLE) .....	6-11
6.7	Generating Triggers on the Power Signal (SIMPLE) .....	6-12
6.8	Setting the Timer Trigger (SIMPLE) .....	6-13
6.9	Setting the Logic Trigger (SIMPLE) .....	6-15
6.10	Setting the A -> B(N) Trigger (ENHANCED) .....	6-17
6.11	Setting the A Delay B Trigger (ENHANCED) .....	6-20
6.12	Setting the Edge on A Trigger (ENHANCED) .....	6-23
6.13	Setting the OR Trigger (ENHANCED) .....	6-27
6.14	Setting the B > Time, B < Time, or B TimeOut (Pulse Width) Trigger (ENHANCED) .....	6-30
6.15	Setting the Period Trigger (ENHANCED) .....	6-34
6.16	Setting the Window Trigger (ENHANCED) .....	6-37
6.17	Setting the Wave Window Trigger (ENHANCED) .....	6-40
6.18	Setting the Action-on-Trigger .....	6-45
6.19	Setting Manual Triggers .....	6-48

**Chapter 7**

**Acquisition and Display**

7.1	Starting/Stopping Waveform Acquisition .....	7-1
7.2	Setting the Record Length .....	7-3
7.3	Setting the Acquisition Mode .....	7-5
7.4	Acquiring Data Using Box Average .....	7-8
7.5	Acquiring Data Using the Sequential Store Function (Single (N) Mode) .....	7-10
7.6	Using the Dual Capture Function .....	7-11
7.7	Realtime Recording to the Internal Hard Disk (Optional) .....	7-16
7.8	Setting the Action When Waveform Display Is Updated (Action-on-Stop) .....	7-20
7.9	Using the Voice Memo Function .....	7-23
7.10	Using the Acquisition Memory Backup Function .....	7-29

**Chapter 8**

**Display**

8.1	Changing the Display Format .....	8-1
8.2	Setting the Display Interpolation Method .....	8-3
8.3	Changing the Graticule .....	8-5
8.4	Accumulated Waveform Display .....	8-6
8.5	Zooming the Waveform .....	8-8
8.6	Displaying X-Y Waveforms .....	8-12
8.7	Using the Snapshot Function and Clear Trace Function .....	8-15
8.8	Turning Translucent Mode ON/OFF .....	8-16
8.9	Turning the Scale Value Display ON/OFF .....	8-17
8.10	Setting Waveform Labels .....	8-18

8.11	Turning the Extra Window ON/OFF .....	8-19
8.12	Turning the Level Indicator and Numeric Value Display ON/OFF .....	8-21
8.13	Displaying Channel Information/Displaying Waveforms on a Full Screen (Expanding the Waveform Area) .....	8-22

**Chapter 9**

**Recording in Recorder Mode (Realtime Recording) (Only on the DL750P)**

9.1	Loading the Roll Paper into the DL750P Built-in Printer .....	9-1
9.2	Selecting the Recorder Mode .....	9-4
9.3	Setting the Record Conditions of T-Y Waveform Recording .....	9-6
9.4	Setting the Recording Format of T-Y Waveform Recording .....	9-8
9.5	Recording T-Y Waveforms (T-Y Waveform Recording) .....	9-12
9.6	Recording Numeric Values .....	9-14
9.7	Recording X-Y Waveforms (X-Y Waveform Recording) .....	9-17
9.8	Reprinting on the Built-in Printer .....	9-21
9.9	Creating a PDF File of the Reprint Image .....	9-26

<b>1</b>
<b>2</b>
<b>3</b>
<b>4</b>
<b>5</b>
<b>6</b>
<b>7</b>
<b>8</b>
<b>9</b>
<b>10</b>
<b>11</b>
<b>12</b>
<b>13</b>
<b>14</b>
<b>15</b>
<b>16</b>
<b>17</b>
<b>18</b>
<b>19</b>
<b>App</b>
<b>Index</b>

## User's Manual Part 2 (See IM701210-06E for the chapters listed below.)

Manuals That Come with the DL750/DL750P .....	Part 2:ii
Functions Described in This Manual and the DL750/DL750P Version .....	Part 2:iv
Flow of Operation .....	Part 2:vi

### Chapter 10 Waveform Computation

10.1 Adding, Subtracting, Multiplying, and Dividing Waveforms .....	10-1
10.2 Binary Computation .....	10-4
10.3 Performing Power Spectrum Computation (FFT) .....	10-7
10.4 Phase-Shifted Display .....	10-11
10.5 User-Defined Computation (Optional) .....	10-14

### Chapter 11 Waveform Analysis/Search

11.1 Displaying History Waveforms .....	11-1
11.2 Searching History Memory Data Using Zones (History Search Function) .....	11-5
11.3 Searching History Memory Data Using Parameters (History Search Function) .....	11-8
11.4 Search Data Using Search and Zoom Function .....	11-11
11.5 Measuring Waveforms Using Cursors .....	11-17
11.6 Automated Measurement of Waveform Parameters .....	11-31
11.7 Performing Statistical Processing .....	11-38
11.8 Performing GO/NO-GO Determination Using Zones .....	11-44
11.9 GO/NO-GO Determination Using Measured Waveform Parameters .....	11-50
11.10 Using the GO/NO-GO Determination I/O Function .....	11-55

### Chapter 12 Printing the Screen Image Data

12.1 Loading the Roll Paper and Paper Feeding .....	12-1
12.2 Printing on the Built-in Printer .....	12-4
12.3 Printing Screen Image Data to a USB Printer .....	12-14
12.4 Printing the Screen Image Data on a Network Printer .....	12-18

### Chapter 13 Saving and Loading Data

13.1 Floppy Disks/Zip Disks/PC Cards .....	13-1
13.2 Internal Hard Disk (Optional) .....	13-6
13.3 Connecting a USB Storage Device (MO Disk Drive, Hard Disk, or Flash Memory) to the USB PERIPHERAL Interface .....	13-7
13.4 Connecting a SCSI Device .....	13-9
13.5 Formatting the Storage Medium .....	13-10
13.6 Changing the SCSI ID Number .....	13-15
13.7 Saving/Loading the Waveform Data .....	13-17
13.8 Saving/Loading the Setup Data .....	13-26
13.9 Saving/Loading Snapshot Waveforms .....	13-31
13.10 Saving the Results of the Automated Measurement of Waveform Parameters ...	13-35
13.11 Saving Screen Image Data .....	13-38
13.12 Displaying Thumbnails of the Saved Screen Image Data .....	13-42
13.13 Creating PDF Files of the Printed Image (DL750P only) .....	13-46
13.14 Loading/Converting Realtime Recorded Waveforms .....	13-53
13.15 Changing the File Attributes and Deleting Files .....	13-56
13.16 Copying Files .....	13-60

	13.17 Changing the Directory/File Name of the Storage Medium and Creating Directories .....	13-63	
△	13.18 Connecting a PC to the DL750/DL750P via SCSI .....	13-67	
	13.19 Using the Voice Comment Function .....	13-70	
<b>Chapter 14</b>	<b>External Trigger I/O, External Clock Input, and Video Signal Output</b>		
△	14.1 External Trigger Input (TRIG IN) .....	14-1	
	14.2 Trigger Output (TRIG OUT) .....	14-2	
△	14.3 External Clock Input (EXT CLK IN) .....	14-3	
△	14.4 Video Signal Output (VIDEO OUT (SVGA)) .....	14-4	
	14.5 External Start/Stop Input (GO/NO-GO) .....	14-6	
<b>Chapter 15</b>	<b>Using the DSP Channel (Optional)</b>		
	15.1 DSP Channels (Optional) .....	15-1	
	15.2 Performing Addition, Subtraction, Multiplication, and Division (DSP Channels) ....	15-3	
	15.3 Using Filters (DSP Channels) .....	15-6	
	15.4 Performing Differentiation and Integration (DSP Channels) .....	15-10	
	15.5 Performing Addition, Subtraction, Multiplication, and Division with Coefficients (DSP Channels) .....	15-13	
	15.6 Using the Knocking Filter (DSP Channels) .....	15-16	
<b>Chapter 16</b>	<b>Ethernet Interface (Optional)</b>		
	16.1 Connecting the DL750/DL750P to the Network .....	16-1	
	16.2 Setting up the TCP/IP .....	16-3	
	16.3 Saving/Loading Data to a Network Drive (FTP Client Function) .....	16-8	
	16.4 Setting up the Network Printer .....	16-12	
	16.5 Sending Periodic Mail or Action Mail (SMTP Client Function) .....	16-14	
	16.6 Accessing the DL750/DL750P from a PC or Workstation (FTP Server Function)	16-20	
	16.7 Using the Web Server Function .....	16-23	
	16.8 Setting the Time Difference from GMT (Greenwich Mean Time)/SNTP .....	16-48	
	16.9 Checking the Presence of the Ethernet Interface and the MAC Address .....	16-50	
	16.10 Setting the FTP Passive Mode and LPR/SMTP Timeout .....	16-51	
	16.11 Using the Instrument as a Windows Network Drive .....	16-52	
<b>Chapter 17</b>	<b>Other Operations</b>		
	17.1 Changing the Menu/Message Language and Turning the Click Sound ON/OFF ..	17-1	
	17.2 Switching the Screen Display Font Size .....	17-2	
	17.3 Changing the USB Keyboard Language .....	17-3	
	17.4 Setting the Screen Color and Brightness .....	17-4	
	17.5 Turning OFF the Backlight and Setting the Brightness of the Backlight .....	17-6	
	17.6 Locking the Keys .....	17-7	
<b>Chapter 18</b>	<b>Troubleshooting, Maintenance, and Inspection</b>		
	18.1 Troubleshooting .....	18-1	
	18.2 Messages and Corrective Actions .....	18-2	
	18.3 Self-Diagnostic Test (Self Test) .....	18-13	
	18.4 Checking the System Conditions (Overview) .....	18-16	
	18.5 Recommended Replacement Parts .....	18-17	

<b>1</b>
<b>2</b>
<b>3</b>
<b>4</b>
<b>5</b>
<b>6</b>
<b>7</b>
<b>8</b>
<b>9</b>
<b>10</b>
<b>11</b>
<b>12</b>
<b>13</b>
<b>14</b>
<b>15</b>
<b>16</b>
<b>17</b>
<b>18</b>
<b>19</b>
<b>App</b>
<b>Index</b>



## Chapter 19

## Specifications

19.1	Input Section .....	19-1
19.2	Trigger Section .....	19-1
19.3	Time Axis .....	19-2
19.4	Display .....	19-3
19.5	Function .....	19-3
19.6	Built-in Printer .....	19-8
19.7	Storage .....	19-9
19.8	USB PERIPHERAL Interface .....	19-10
19.9	Auxiliary I/O Section .....	19-10
19.10	Computer Interface .....	19-13
19.11	General Specifications .....	19-14
19.12	Module Specifications .....	19-18
19.13	Logic Probe Specifications .....	19-41
19.14	External Dimensions .....	19-42

## Appendix

Appendix 1	Relationship between the Time Axis Setting, Sample Rate and Record Length .....	App-1
Appendix 2	Relationship between the Record Length and Acquisition Mode .....	App-5
Appendix 3	How to Calculate the Area of a Waveform .....	App-7
Appendix 4	ASCII Header File Format .....	App-9
Appendix 5	User-Defined Computation .....	App-14
Appendix 6	DSP Channel Computation (Optional) .....	App-23
Appendix 7	List of Defaults .....	App-46
Appendix 8	Assignment of Keys on the USB Keyboard .....	App-49
Appendix 9	Waveform Acquisition Operation When the Power Supply Recovers after a Power Failure .....	App-53
Appendix 10	Basic Defining Equation of Strain .....	App-54
Appendix 11	Shunt Calibration of the Strain Module .....	App-55
Appendix 12	Measurement Principles (Measurement Method and Update Rate) of the Frequency Module .....	App-60
Appendix 13	List of Preset Settings of the Frequency Module .....	App-64
Appendix 14	TCP and UDP Port Number Used in Ethernet Communications .....	App-66
Appendix 15	Relationship between the Chart Speed, Sample Rate, and Record Length during Recorder Mode .....	App-67

## Index

**DL750/DL750P**  
**ScopeCorder**

**U S E R ' S M A N U A L**

---

**Part 1**   **Part 2**

***GiGAZoom***  
ENGINE™

# Product Registration

Thank you for purchasing YOKOGAWA products.

YOKOGAWA provides registered users with a variety of information and services.

Please allow us to serve you best by completing the product registration form accessible from our homepage.

**<http://tmi.yokogawa.com/>**

---

Thank you for purchasing the DL750/DL750P ScopeCorder. This user's manual contains useful information about the instrument's functions and operating procedures and lists the handling precautions of the DL750/DL750P. It mainly focuses on the DL750. The user's manual is divided into two parts, Part 1 and Part 2. For details on the information covered in Part 1 and Part 2 as well as other DL750/DL750P manuals, see "Manuals That Come with the DL750/DL750P" on the next page. To ensure correct use, please read this manual thoroughly before beginning operation. After reading the manual, keep it in a convenient location for quick reference whenever a question arises during operation.

## Notes

- The contents of this manual are subject to change without prior notice as a result of continuing improvements to the instrument's performance and functions. The figures given in this manual may differ from those that actually appear on your screen.
- Every effort has been made in the preparation of this manual to ensure the accuracy of its contents. However, should you have any questions or find any errors, please contact your nearest YOKOGAWA dealer.
- Copying or reproducing all or any part of the contents of this manual without the permission of Yokogawa Electric Corporation is strictly prohibited.
- The TCP/IP software of this product and the document concerning the TCP/IP software have been developed/created by YOKOGAWA based on the BSD Networking Software, Release 1 that has been licensed from University of California.

## Trademarks

- Microsoft, Internet Explorer, MS-DOS, Windows, Windows NT, and Windows XP are either registered trademarks or trademarks of Microsoft Corporation in the United States and/or other countries.
- Adobe, Acrobat, and PostScript are trademarks of Adobe Systems Incorporated.
- Zip is either a registered trademark or trademark of Iomega Corporation in the United States and/or other countries.
- UNIX is either a registered trademark or trademark of The Open Group in the United States and/or other countries.
- Piezotron is a registered trademark of Kistler Instrument Corporation.
- ICP is a registered trademark of PCB Piezotronics Incorporated.
- ISOTRON is a registered trademark of ENDEVCO Corporation.
- GIGAZOOM ENGINE are pending trademark of Yokogawa Electric Corporation.
- For purposes of this manual, the TM and ® symbols do not accompany their respective trademark names or registered trademark names.
- Other company and product names are trademarks or registered trademarks of their respective holders.

## Revisions

- 1st Edition: February 2005
- 2nd Edition: May 2005
- 3rd Edition: December 2005
- 4th Edition: May 2009

---

## Waste Electrical and Electronic Equipment



### **Waste Electrical and Electronic Equipment (WEEE), Directive 2002/96/EC**

(This directive is only valid in the EU.)

This product complies with the WEEE Directive (2002/96/EC) marking requirement. This marking indicates that you must not discard this electrical/electronic product in domestic household waste.

### **Product Category**

With reference to the equipment types in the WEEE directive Annex 1, this product is classified as a “Monitoring and Control instrumentation” product.

Do not dispose in domestic household waste. When disposing products in the EU, contact your local Yokogawa Europe B. V. office.

# Manuals That Come with the DL750/DL750P

## DL750/DL750P Manuals

The following manuals are provided for the DL750/DL750P. Use them according to your application.

### User's Manual Part 1

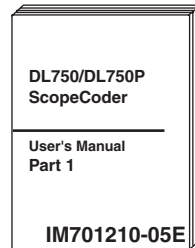

This manual. Contains chapters 1 to 9 of the DL750/DL750P User's Manual. Mainly describes the basic operations of the DL750/DL750P up to waveform acquisition.

#### [Contents]

- **Chapter 1** **Names and Functions of Parts**
- **Chapter 2** **Explanation of Functions**
- **Chapter 3** **Making Preparations for Measurements**
- **Chapter 4** **Common Operations**  
Operations and functions of keys and the jog shuttle, entering values and strings, operations on the USB keyboard/USB mouse, initializing settings, auto setup, calibration, and help function
- **Chapter 5** **Horizontal and Vertical Axes**
- **Chapter 6** **Triggering**
- **Chapter 7** **Acquisition and Display**  
Record length, acquisition mode, sequential store, dual capture, realtime recording to the internal hard disk, voice memo, and acquisition memory backup
- **Chapter 8** **Waveform Display and Information Display**
- **Chapter 9** **Recording in Recorder Mode (Realtime Recording) (DL750P Only)**
- **Index** Common to Part 1 and Part 2.

### User's Manual Part 2

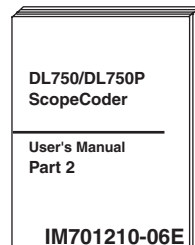

Contains chapters 10 to 19 and appendix of the DL750/DL750P User's Manual. Mainly describes operations after waveform acquisition and optional functions.

#### [Contents]

- **Chapter 10** **Waveform Computation**
- **Chapter 11** **Waveform Analysis/Search**  
Displaying of history waveforms, history search, search & zoom, cursor measurements, automated measurement of waveform parameters, statistical processing, and GO/NO-GO determination
- **Chapter 12** **Printing the Screen Image Data**
- **Chapter 13** **Saving and Loading Data**
- **Chapter 14** **External Trigger I/O, External Clock Input, and Video Signal Input**
- **Chapter 15** **Using the DSP Channel (Optional)**
- **Chapter 16** **Ethernet Interface (Optional)**
- **Chapter 17** **Other Operations**  
Changing the menu/message language, turning the click sound ON/OFF, changing the USB keyboard language, checking the USB keyboard, setting the screen color/brightness, setting the backlight, and locking the keys
- **Chapter 18** **Troubleshooting, Maintenance, and Inspection**
- **Chapter 19** **Specifications**
- **Appendix**
- **Index** Common to Part 1 and Part 2.

**Operation Guide**

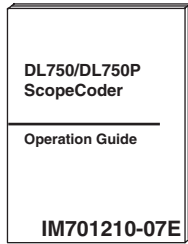

Familiarizes the first-time user with the basic operations of the DL750/DL750P. Latter half of the guide summarizes key points of each setup menu. Use this as a guide when setting up the DL750/DL750P.

**[Contents]**

- **Flow of DL750/DL750P Operation**
- **Front Panel Controls**
- **Parts of the Screen**
- **Basic Key & Jog Shuttle Operations**
- **Main Functions of the DL750/DL750P**
- **Operating the DL750/DL750P**

Making preparations before observation, displaying waveforms, changing the waveform display conditions, changing the trigger settings, measuring waveforms, zooming the waveform along the time axis, and printing/saving waveforms

- **Setup Menu Items**

**Communication Interface User's Manual**

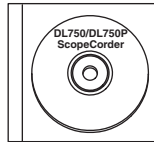

B8023YZ

A manual in PDF format that is stored in the accompanying CD-ROM. Describes the functions of each communication interface on the DL750/DL750P and commands.

**[Contents]**

- **Chapter 1 Overview of the GP-IB Interface**
- **Chapter 2 Overview of the Serial (RS-232) Interface**
- **Chapter 3 Overview of the USB Interface**
- **Chapter 4 Overview of the Ethernet Interface (Optional)**
- **Chapter 5 Before Programming**
- **Chapter 6 Commands**
- **Chapter 7 Status Reports**
- **Chapter 8 Sample Programs**
- **Appendix**
- **Index**

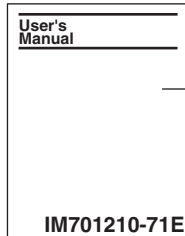

**Handling of the Communication Interface User's Manual CD-ROM**

Describes the handling precautions of the Communication Interface User's Manual CD-ROM.

# Checking the Contents of the Package

Unpack the box and check the contents before operating the instrument. If some of the contents are not correct, or if any items are missing or damaged, contact the dealer from whom you purchased them.

## DL750/DL750P

Check that the model name and suffix code given on the name plate on the left side panel of the CDM Signal Generator match those on your order. When contacting the dealer from which you purchased the instrument, please give them the instrument number.

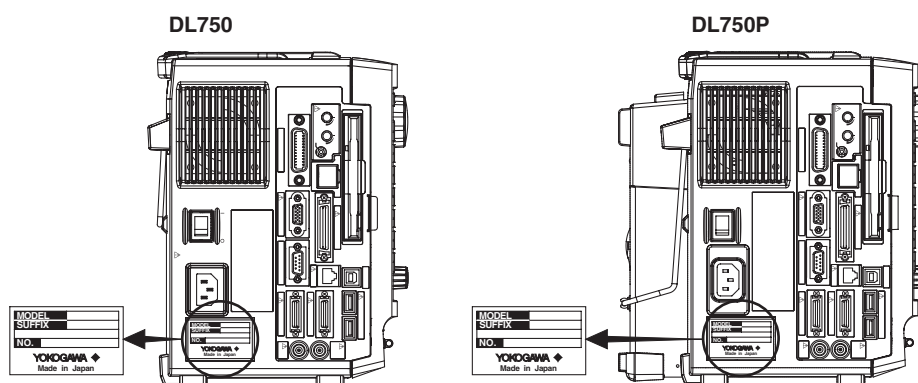

MODEL	Suffix Code	Description
701210 (DL750)		The input module is not included with the instrument. See the next page for information on the input module.
701230 (DL750P)		
Power cord	-D	UL/CSA Standard power cord (Part No.: A1006WD) [Maximum rated voltage: 125 V; Maximum rated current: 7A]
	-F	VDE Standard Power Cord (Part No.: A1009WD) [Maximum rated voltage: 250 V; Maximum rated current: 10 A]
	-Q	BS Standard Power Cord (Part No.: A1054WD) [Maximum rated voltage: 250 V; Maximum rated current: 10 A]
	-R	AS Standard Power Cord (Part No.: A1024WD) [Maximum rated voltage: 250 V; Maximum rated current: 10 A]
	-H	GB Standard Power Cord (Part No.: A1064WD) [Maximum rated voltage: 250 V; Maximum rated current: 10 A]
Default language	-HE	English
	-HJ	Japanese
	-HC	Chinese
	-HK	Korean
	-HG	German
	-HF	French
	-HL	Italian
	-HS	Spanish
Built-in media drive	-J1	Floppy disk drive <sup>*1</sup>
	-J2	Zip drive <sup>*1</sup> (DL750 only)
	-J3	PC card drive <sup>*1</sup>
Options	/M1	Memory extension to 10 MW/CH <sup>*2</sup> (250 MW maximum)
	/M2	Memory extension to 25 MW/CH <sup>*2</sup> (500 MW maximum)
	/M3	Memory extension to 50 MW/CH <sup>*2</sup> (1 GW maximum)
	/C8	Internal hard disk 30 GB (FAT32)
	/C10	Ethernet interface
	/DC	12 VDC Power (10 to 18 VDC) (DL750 only)
	/G2	User-defined computation
	/G3	DSP channel
/P4	Four probe power outputs	

\*1 For the built-in media drive on the DL750, select one from three types (two types for the DL750P).

\*2 Choose one from /M1, /M2, and /M3.

### No. (Instrument Number)

When contacting the dealer from which you purchased the instrument, please give them the instrument number.



## Checking the Contents of the Package

### Standard Accessories

The standard accessories below are supplied with the instrument. Check that all contents are present and undamaged.

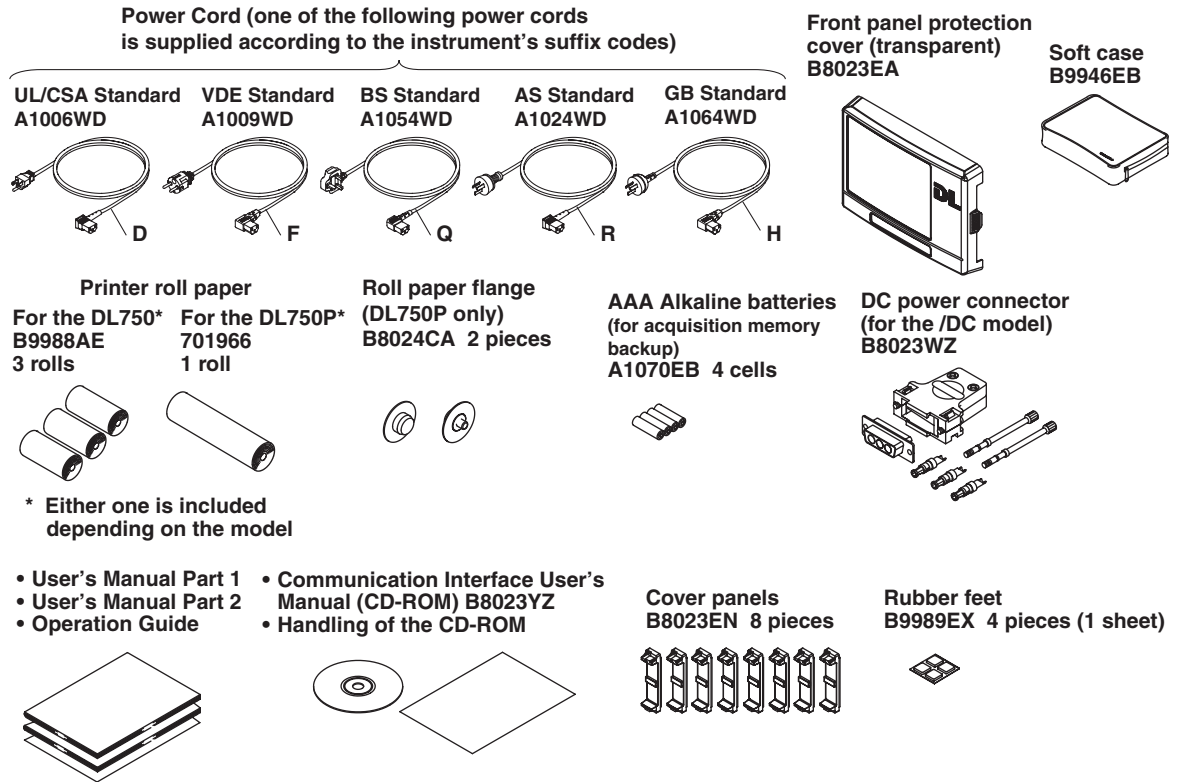

### Input Modules (Sold Separately)

Check that the MODEL indicated on the input module is what you ordered.

MODEL	Name	Abbreviation
701250	High-Speed 10 MS/s, 12-Bit Isolation Module	HS10M12
701251	High-Speed High-Resolution 1 MS/s, 16-Bit Isolation Module	HS1M16
701255	High-Speed 10 MS/s, 12-Bit Non-Isolation Module	NONISO_10M12
701260	High-Voltage 100 kS/s, 16-Bit Isolation Module (with RMS)	HV (with RMS)
701261	Universal (Voltage/Temp.) Module	UNIVERSAL
701262	Universal (Voltage/Temp.) Module (with AAF)	UNIVERSAL (AAF)
701265	Temperature, High Precision Voltage Isolation Module	TEMP/HPV
701270	Strain Module (NDIS)	STRAIN_NDIS
701271	Strain Module (DSUB, Shunt-Cal)	STRAIN_DSUB
701275	Acceleration/Voltage Module (with AAF)	ACCL/VOLT
701280	Frequency Module	FREQ

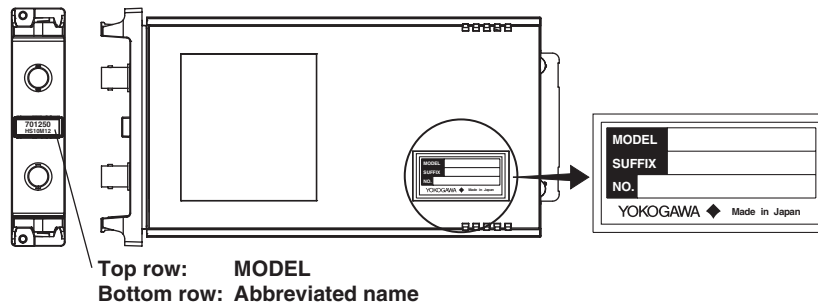

This user's manual refers to the input modules by MODEL (abbreviation).

For example, the High-Speed 10 MS/s, 12-Bit Isolation Module is indicated as 701250 (HS10M12). However, the module may be indicated only by the model (701250) if a description about the same module is given immediately before it.

## Optional Accessories (Sold Separately)

The optional accessories below are available for purchase separately. Check that all contents are present and undamaged. For information and ordering, contact your nearest YOKOGAWA dealer.

Name	Model	Safety standard <sup>*1</sup>	Description
1. Isolated probe	700929	1000 Vrms CAT II	10:1 safety probe, for the 701250/701251
2. Current probe	700937	300 Vrms CAT I	DC to 50 MHz bandwidth,Used by connecting to the probe power terminal
3. Current probe	701930	300 Vrms CAT III	DC to 10 MHz bandwidth,Used by connecting to the probe power terminal
4. Current probe	701931	300 Vrms CAT III	DC to 2 MHz bandwidth,Used by connecting to the probe power terminal
5. Current probe	701933	300 Vrms CAT I	DC to 50 MHz bandwidth, Used by connecting to the probe power terminal
6. Differential probe	700924	1000 Vrms CAT III <sup>*2</sup>	Switchable between 1000:1 and 100:1 Measurable voltage: 1400 Vpeak (1000 Vrms)
7. 10:1 Passive Probe for the DL750/DL750P	701940	-	For non-isolated input on the 701255: 600 V or less For isolated input other than above: 42 V or less
8. 1:1 BNC safety adapter lead	701901	1000 Vrms CATII	Used with the 701954, 701959, 758922, 758929, or 758921 sold separately
9. Alligator clip (dolphin type)	701954	1000 Vrms CAT III	2 pieces in one set (red/black)
10. Safety mini-clip (hook type)	701959	1000 Vrms CAT II	2 pieces in one set (red/black)
11. Alligator clip adapter	758922	300 Vrms CAT II	2 pieces in one set
12. Alligator clip adapter	758929	1000 Vrms CAT II	2 pieces in one set
13. Fork terminal adapter	758921	1000 Vrms CAT II	2 pieces in one set (red/black), for 4-mm screws
14. Cable <sup>*3</sup>	366926	-	For measuring low voltage of less than or equal to 42 V
15. Banana-alligator clip cable	366961	-	For measuring low voltage of less than or equal to 42 V for the 701261, 701262, or 701265
16. High-speed logic probe	700986	-	42 V or less, 8-bit non-isolated/response speed of 1 $\mu$ s
17. Isolated logic probe	700987	250 Vrms CAT II	8 bits, each channel isolated, response speed of 20 ms (for AC)
18. Measurement lead for isolated logic	758917	1000 Vrms CAT II	2 pieces in one set, used with the 758922 or 758929 adapter sold separately
19. Conversion adapter	366928	-	42 V or less,BNC (jack) to RCA (plug)
20. GO/NO-GO cable	366973	-	For GO/NO-GO determination I/O function
21. Earphone microphone PUSH switch	701951	-	For recording and playing voice memo/with a comment
22. Speaker cable	701952	-	For playing voice memo/comment
23. Safety BNC cable (1 m)	701902	1000 Vrms CAT II	
24. Safety BNC cable (2 m)	701903	1000 Vrms CAT II	
25. Safety BNC-to-banana adapter	758924	500 Vrms CAT II	
26. Bridge head	701955	-	NDIS, bridge resistance: 120 $\Omega$
	701956	-	NDIS, bridge resistance: 350 $\Omega$
	701957	-	DSUB, bridge resistance: 120 $\Omega$ , shunt-cal support
	701958	-	DSUB, bridge resistance: 350 $\Omega$ , shunt-cal support
27. Soft carrying case	701963	-	For the DL750 with three pockets
	701967	-	For the DL750P with three pockets
28. DC power cord (Cigarette lighter plug type)	701970	-	For the DC power supply model (/DC)
29. DC power cord (Alligator clip type)	701971	-	For the DC power supply model (/DC)













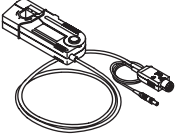
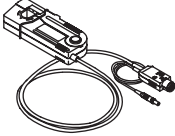
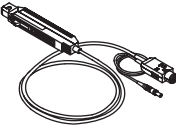
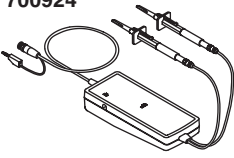
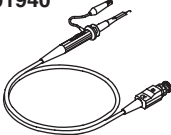







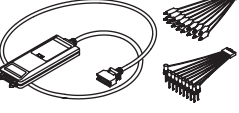
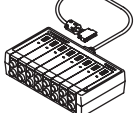
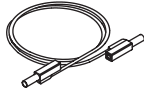

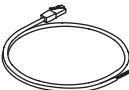
Sold in units of 1 piece.

\*1 The actual voltage that can be used is the lower voltage of the specifications of the DL750/DL750P and the cable.

\*2 Be sure to connect the GND lead provided with the 700924 to the functional ground terminal of the DL750/DL750P. A measurement of 1400 Vpeak is possible by connecting the GND lead to the DL750/DL750P.

\*3 Use cables (366926) that YOKOGAWA has been shipping since February 4, 1998. Cables (366926) shipped before this date cannot be used in combination with the DL750/DL750P input modules.

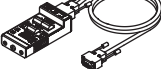
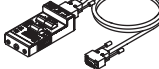
## Checking the Contents of the Package

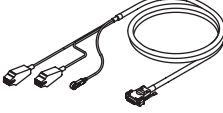
- |                                                                                                                                                                    |                                                                                                                                                   |                                                                                                                                             |                                                                                                                                   |                                                                                                                                     |
|--------------------------------------------------------------------------------------------------------------------------------------------------------------------|---------------------------------------------------------------------------------------------------------------------------------------------------|---------------------------------------------------------------------------------------------------------------------------------------------|-----------------------------------------------------------------------------------------------------------------------------------|-------------------------------------------------------------------------------------------------------------------------------------|
| 1. Isolated probe<br>700929<br>                                                   | 2. Current probe<br>700937<br>                                   | 3. Current probe<br>701930<br>                             | 4. Current probe<br>701931<br>                  | 5. Current probe<br>701933<br>                   |
| 6. Differential probe<br>700924<br>                                               | 7. 10:1 Passive Probe for the DL750/DL750P<br>701940<br>         | 8. 1:1 BNC safety dapter lead<br>701901*<br>               | 9. Alligator clip (dolphin type)<br>701954<br> | 10. Safety mini-clip (hook type)<br>701959<br>   |
| 11. Alligator clip adapter (Rated voltage 300 V)<br>758922<br>                    | 12. Alligator clip adapter (Rated voltage 1000 V)<br>758929<br>  | 13. Fork terminal adapter<br>758921<br>                    | 14. Cable<br>366926<br>                         | 15. Banana-alligator clip cable<br>366961<br>    |
| 16. High-speed logic probe<br>700986<br>                                         | 17. Isolated logic probe<br>700987<br>                          | 18. Measurement lead for isolated logic<br>758917*<br>    | 19. Conversion adapter<br>366928<br>          | 20. GO/NO-GO cable<br>366973<br>                |
| 21. Earphone microphone with a PUSH switch<br>701951<br>                        | 22. Speaker cable<br>701952<br>                                | 23. Safety BNC cable (1 m)<br>701902<br>                 | 24. Safety BNC cable (2 m)<br>701903<br>     | 25. Safety BNC-to-banana adapter<br>758924<br> |
| 26. Bridge head<br>701955 (NDIS, 120 Ω)<br>                                     | 26. Bridge head<br>701956 (NDIS, 350 Ω)<br>                    | 26. Bridge head<br>701957 (DSUB, 120 Ω)<br>              | 26. Bridge head<br>701958 (DSUB, 350 Ω)<br>  |                                                                                                                                     |
| 27. Soft carrying case<br>701963 (for the DL750)<br>701967 (for the DL750P)<br> | 28. DC power cable (Cigarette lighter plug type)<br>701970<br> | 29. DC power cable (Alligator clip type)<br>701971<br> |                                                                                                                                   |                                                                                                                                     |

\* Used by combining the alligator clip (dolphin type 701954), safety mini-clip (hook type: 701959), alligator adapter (758922 or 758929), and/or the fork terminal adapter (758921) accessories sold separately.

## Spare Parts (Sold Separately)

The spare parts below are available for purchase separately. Check that all contents are present and undamaged.

For information about the spare parts and ordering, contact your dealer.

Name	Part No.	Minimum Q'ty	Note
Printer roll paper (for the DL750)	B9988AE	10	Thermo-sensitive paper, 111 mm × 10 m
Printer roll paper (for the DL750P)	701966	6	Thermo-sensible paper, 210 mm × 20 m

---

# Safety Precautions

This instrument is an IEC safety class I instrument (provided with a terminal for protective earth grounding).

The general safety precautions described herein must be observed during all phases of operation. If the instrument is used in a manner not specified in this manual, the protection provided by the instrument may be impaired. Yokogawa Electric Corporation assumes no liability for the customer's failure to comply with these requirements.

## The following symbols are used on this instrument.



Warning: handle with care. Refer to the user's manual or service manual. This symbol appears on dangerous locations on the instrument which require special instructions for proper handling or use. The same symbol appears in the corresponding place in the manual to identify those instructions.



Protective grounding terminal



Functional ground terminal (do not use this terminal as a protective ground terminal.)



Alternating current



ON (power)



OFF (power)

**Be sure to observe with the precautions below. Not complying might result in injury or death.**



---

### **WARNING**

- **Use the Correct Power Supply**  
Before connecting the power cord, ensure that the source voltage matches the rated supply voltage of the instrument and that it is within the maximum rated voltage of the provided power cord.
- **Use the Correct Power Cord and Plug**  
To prevent the possibility of electric shock or fire, be sure to use the power cord supplied by YOKOGAWA. The main power plug must be plugged into an outlet with a protective earth terminal. Do not disable this protection by using an extension cord without protective earth grounding.
- **Connect the Protective Grounding Terminal**  
Make sure to connect the protective earth to prevent electric shock before turning ON the power. The power cord that comes with the instrument is a three-prong type power cord. Connect the power cord to a properly grounded three-prong outlet.
- **Do Not Impair the Protective Grounding**  
Never cut off the internal or external protective grounding wire or disconnect the wiring of the protective grounding terminal. Doing so poses a potential shock hazard.
- **Do Not Operate with Defective Protective Grounding or Fuse**  
Do not operate the instrument if the protective grounding or fuse might be defective. Also, make sure to check them before operation.
- **Do Not Operate in an Explosive Atmosphere**  
Do not operate the instrument in the presence of flammable liquids or vapors. Operation in such an environment constitutes a safety hazard.
- **Do Not Remove Covers**  
The cover should be removed by YOKOGAWA's qualified personnel only. Opening the cover is dangerous, because some areas inside the instrument have high voltages.
- **Ground the Instrument before Making External Connections**  
Securely connect the protective grounding before connecting to the item under measurement or to an external control unit. If you are going to touch the circuit, make sure to turn OFF the circuit and check that no voltage is present.
- **Precautions to Be Taken When Using the DC Power Supply**
  - Make sure to perform protective earth grounding to prevent electric shock.
  - Connect the DC power cord after checking that the power switch of the instrument is turned OFF. If you connect the power cord with the power switch turned ON, sparks may be emitted and can lead to fire.
- **Precautions to Be Taken When Using the Modules**
  - Do not apply input voltage exceeding the maximum input voltage, withstand voltage, or allowable surge voltage.
  - To prevent the possibility of electric shock, be sure to furnish protective earth grounding of the DL750/DL750P.
  - To prevent the possibility of electric shock, be sure to fasten the module screws. Otherwise, the electrical protection function and the mechanical protection function will not be activated.
  - Avoid continuous connection under an environment in which the allowable surge voltage or greater voltage may occur.

- **Precautions to Be Taken When Using the Probes**
  - When measuring high voltages using the 701250 (HS10M12) or the 701251 (HS1M16), use isolated probes (700929), 1:1 safety cable (combination of 701901 and 701954), or differential probes (700924).
  - Be sure to connect the GND lead of the differential probe (700924) to the functional ground terminal of the DL750/DL750P. High voltage may appear at the BNC connector of the differential probe. Be sure to connect the GND lead to the DL750/DL750P before connecting the probe to the parameter to be measured.
  - When using the 701255 (NONISO\_10M12), be sure to fasten the module screws. Fastening the module screws activates the protection function and the non-isolation function. It is extremely dangerous if you do not fasten the screws. In addition, when measuring high voltage above 42 V, be sure to use the Passive Probe for the DL750/DL750P (701940).
  - The BNC part of the Passive Probe for the DL750/DL750P (701940) is made of metal. Therefore, use the probe at 42 V or less for isolated inputs (701250 (HS10M12), 701251 (HS1M16), 701260 (HV(with RMS)), etc.) for safety reasons. (Do not connect voltage above 42 V to both the High and Low sides.) For non-isolated inputs (701255 (NONISO\_10M12), etc.), fasten the module screws as described before.
  - When applying high voltage using the 701260 (HV(with RMS)), use the 1:1 safety cable (combination of 701901 and 701954) or the isolated probe (700929).
  - The measurement category of the 701260 (HV (with RMS)) is 400V-CAT II for the low side and 700V-CAT II for the high side. Use caution because the overvoltage tolerance differs between the low and high sides.
- 

**See below for operating environment limitations.**

---

### **CAUTION**

This product is a Class A (for industrial environments) product. Operation of this product in a residential area may cause radio interference in which case the user will be required to correct the interference.

---

---

# Conventions Used in This Manual

## Unit

- k: Denotes 1000. Example: 100 kS/s (sampling rate)  
K: Denotes 1024. Example: 720 KB (storage capacity of a floppy disk)

## Displayed Characters

- Bold characters used in the procedural explanations indicate characters that are marked on the panel keys or the characters of the soft keys displayed on the screen menu.
- The SHIFT + xxx key refers to first pressing the SHIFT key (the indicator above the SHIFT key lights), and then pressing the xxx key. The menu marked in purple below the pressed key appears on the screen.

## Safety Markings

The following markings are used in this manual.



*Improper handling or use can lead to injury to the user or damage to the instrument.* This symbol appears on the instrument to indicate that the user must refer to the user's manual for special instructions. The same symbol appears in the corresponding place in the user's manual to identify those instructions. In the manual, the symbol is used in conjunction with the word "WARNING" or "CAUTION."

## WARNING

Calls attention to actions or conditions that could cause serious or fatal injury to the user, and precautions that can be taken to prevent such occurrences.

## CAUTION

Calls attentions to actions or conditions that could cause light injury to the user or damage to the instrument or user's data, and precautions that can be taken to prevent such occurrences.

## Note

Calls attention to information that is important for proper operation of the instrument.

## Subheadings

On pages that describe the operating procedure in chapters 3 through 9 of Part 1 and chapters 10 through 18 in Part 2, the following symbols are used to distinguish the procedure from their explanations.

### **Procedure**

Follow the numbered steps. All procedures are written with inexperienced users in mind; experienced users may not need to carry out all the steps.

### **Explanation**

This section describes the setup items and the limitations regarding the procedures. A detailed description of the function is not provided in this section. For details on the function, see chapter 2.

# Functions Described in This Manual and the DL750/ DL750P Version

The contents of this manual describe the DL750/DL750P version 6.20 or later. The table below shows the relationship between the DL750/DL750P versions and the new functions and supported modules. If the DL750/DL750P is not of the newest version, you will not be able to use all the functions covered in this manual. Check the DL750/DL750P version by referring to Soft Version on the overview screen that appears by selecting the MISC key > Overview soft key. For details on the procedure, see section 18.4 in the User's Manual Part 2. For up-to-date information about the DL750/DL750P versions and the procedure for upgrading your DL750/DL750P, check the following Web page.

<http://www.yokogawa.com/tm/DL750/>

## DL750/DL750P Versions and New Functions

Version	Suffix Code	New Functions	Reference Page/Section/Chapter
1.09 or later	Standard	<ul style="list-style-type: none"> <li>Voice memo and voice comment</li> </ul>	<i>Pages 2-36 and 2-64, sections 7.9 and 13.19</i>
2.02 or later	Standard  /G3	<ul style="list-style-type: none"> <li>Wave window trigger</li> <li>Cycle statistical processing</li> <li>Chinese menu and message support</li> <li>DSP channels</li> </ul>	<i>Page 2-26 and section 6.17 Page 2-57 and section 11.7 Section 17.1 Page 2-50, chapter 15, and appendix 6</i>
3.01 or later	Standard  /G3	<ul style="list-style-type: none"> <li>Numeric monitor display</li> <li>Added exponential window to FFT computation/increased number of points in FFT computation (up to 100 kpoints).</li> <li>Normal statistical processing/statistical processing of history memory</li> <li>Increased the number of parameters for automated measurement/statistical processing of waveform parameters (Up to 24000 increased to up to 48000)</li> <li>Added waveform data save formats for action-on-trigger and GO/NO-GO determination (select from binary, ASCII, and floating)</li> <li>Support for inverted display on the strain module</li> <li>Support for current probe (701931)</li> <li>Support for enhanced trigger (OR trigger and window trigger) on DSP channels</li> <li>Knocking filter</li> </ul>	<i>Page 2-39 and section 8.13 Page 2-47, section 10.5, page app-21 Page 2-57 and section 11.7 Sections 11.6 and 11.7  Pages 2-29 and 2-58, and Section 13.7 Page 2-14 and section 5.12 Page 2-9 and section 3.6 Pages 2-22 and 2-26, chapter 15 Section 15.6</i>
3.10 or later	Standard	<ul style="list-style-type: none"> <li>Added Korean to the menu languages. Added Korean, German, French, and Italian to message languages.</li> </ul>	<i>Section 17.1</i>
4.01 or later	Standard  Standard, /G3 /C10  /DC	<ul style="list-style-type: none"> <li>Changed the number of screens that can be captured on the dual capture function</li> <li>Selection of the traces to be displayed on the dual capture function</li> <li>Mail transmission using the dual capture trigger function</li> <li>Automated measurement of waveform parameters on the dual capture function</li> <li>Added the action on stop function.</li> <li>Parameter search of the history memory function</li> <li>Added H&amp;V cursor measurement to T-Y waveforms</li> <li>Filter Hz display</li> <li>SNTP function</li> <li>WebDAV server function</li> <li>Mail attachment function of image data</li> <li>Added the DC power supply option (DL750 only)</li> </ul>	<i>Page 2-34 and section 7.6  section 7.6 section 7.6 section 11.6  section 7.8 section 11.3 section 11.5 Sections 10.5 and 15.3 Sections 3.5 and 16.8 Section 16.11 Section 16.5 Section 3.4</i>
4.02 or later	Standard	<ul style="list-style-type: none"> <li>START/STOP key response time</li> </ul>	<i>Section 7.1</i>
5.01 or later	Standard	<ul style="list-style-type: none"> <li>Recording in recorder mode (DL750P only)</li> <li>Connection of USB storage device to the USB PERIPHERAL interface (DL750P only)</li> <li>Creation of PDF files of the printed image (DL750P only)</li> <li>Support for current probe (701933)</li> <li>Added 16 divided windows to the display format</li> <li>Added the output format to the built-in printer (Zoom Print) and changed the name of the function Long copy to Fine print</li> <li>Added the linear scaling display format</li> </ul>	<i>Chapter 9 Section 13.3  Section 13.13 Page 2-9 and section 3.6 Section 8.1 Section 12.2  Section 5.11</i>
6.01 or later	Standard  Standard, /G2	<ul style="list-style-type: none"> <li>Creation of PDF files of the reprint image in X-Y Recorder Mode (DL750P only)</li> <li>Creation of PDF files of the printed image (X-Y waveform) (DL750P only)</li> <li>Overall value display of the power spectrum computation (FFT)</li> </ul>	<i>Section 9.9  Section 13.3 Section 10.13, 10.5, 11.6, and page App-19</i>



## Functions Described in This Manual and the DL750/DL750P Version

Version	Suffix Code	New Functions	Reference Page/Section/Chapter
6.02 or later	Standard	<ul style="list-style-type: none"> <li>Connection of USB storage device to the USB PERIPHERAL interface (DL750)*</li> </ul>	<a href="#">Section 13.3</a>
6.20 or later	Standard	<ul style="list-style-type: none"> <li>Added waveform icons to the title of the CH/DSP/LOGIC/EVENT setup menus.</li> <li>Added All ON of Variable (Var.) to the all channel setup menu.</li> <li>Added ACQ Count to the action-on-trigger/action-on-stop setup menu.</li> <li>Added bandwidth limit to the channel information during temperature/strain measurement.</li> </ul>	<a href="#">Section 5.1</a> <a href="#">Section 5.13 (section 5.9)</a> <a href="#">Sections 6.18 and 7.8</a> <a href="#">Section 8.13</a>
		[Recording in recorder mode (DL750P only)] <ul style="list-style-type: none"> <li>Added an Extra Area ON/OFF function when the format is set to Dual, Triad, or Quad in the print settings of Chart Recorder mode.</li> <li>Added the Fine setting to Gauge in the print settings of Chart Recorder mode.</li> <li>Added A4 print to the print length during reprint in Chart Recorder mode.</li> <li>Selection of the print font size (Print Font) in the print settings of X-Y Recorder mode.</li> </ul>	<a href="#">Section 9.4</a> <a href="#">Section 9.4</a> <a href="#">Section 9.8</a> <a href="#">Section 9.7</a>
		<ul style="list-style-type: none"> <li>Support for phase shift even when external clock is selected.</li> </ul>	<a href="#">Section 10.4</a>
		[Printing on the built-in printer (DL750P only)] <ul style="list-style-type: none"> <li>Added A4 print to the output format.</li> <li>Added an Extra Area ON/OFF function when the format is set to Dual, Triad, or Quad in the print settings of fine print, zoom print, and A4 print.</li> <li>Added the Fine setting to Gauge in the print settings of fine print, zoom print, and A4 print.</li> <li>Creation of PDF files of the print image when all waveform display (Display Mode: All) is selected in the history memory function (DL750P only).</li> </ul>	<a href="#">Section 12.2</a> <a href="#">Section 12.2</a> <a href="#">Section 12.2</a> <a href="#">Section 13.13 (section 11.1)</a>
		<ul style="list-style-type: none"> <li>Added a function for switching the screen display font size (large or small).</li> </ul>	<a href="#">Chapter 17</a>
	/G2	<ul style="list-style-type: none"> <li>Added DUTYH and DUTYL to the user-defined computation.</li> </ul>	<a href="#">Section 10.5</a>

\* Applicable to DL750s on which "USB Storage: Yes" is displayed on the overview screen that appears when you press the MISC key followed by the Overview soft key.

## DL750/DL750P Versions and Supported Modules

Version	Supported Modules Reference Page Vertical Axis Settings	Specifications Concerning Horizontal/	Reference Section
1.07 or later	701250 High-Speed 10 MS/s, 12-Bit Isolation Module 701251 High-Speed High-Resolution 1 MS/s, 16-Bit Isolation Module 701265 Temperature, High Precision Voltage Isolation Module	<a href="#">Page 19-18</a> <a href="#">Page 19-20</a> <a href="#">Page 19-29</a>	<a href="#">Sections 5.1 to 5.15</a> <a href="#">Sections 5.1 to 5.15</a> <a href="#">Sections 5.1, 5.2, 5.5, 5.7, 5.13, 5.14, and 5.16</a>
2.02 or later	701255 High-Speed 10 MS/s, 12-Bit Non-Isolation Module 701260 High-Voltage 100 kS/s, 16-Bit Isolation Module (with RMS) 701270 Strain Module (NDIS) 701271 Strain Module (DSUB, Shunt-Cal)	<a href="#">Page 19-22</a> <a href="#">Page 19-24</a> <a href="#">Page 19-31</a> <a href="#">Page 19-33</a>	<a href="#">Sections 5.1 to 5.15</a> <a href="#">Sections 5.1 to 5.15</a> <a href="#">Sections 5.1, 5.2, 5.7, 5.11 to 5.14, and 5.17</a> <a href="#">Sections 5.1, 5.2, 5.7, 5.11 to 5.14, and 5.17</a>
3.01 or later	701275 Acceleration/Voltage Module (with AAF) 701280 Frequency Module	<a href="#">Page 19-35</a> <a href="#">Page 19-37</a>	<a href="#">Sections 5.1, 5.2, 5.4, 5.5, 5.7 to 5.9, 5.13, 5.14, and 5.18*</a> <a href="#">Sections 5.19, 5.1, 5.2, 5.4, 5.8 to 5.11, 5.13, and 5.14</a>
5.01 or later	701261 Universal (Voltage/Temp.) Module 701262 Universal (Voltage/Temp.) Module (with AAF)	<a href="#">Page 19-26</a> <a href="#">Page 19-26</a>	<a href="#">Sections 5.1, 5.2, 5.4, 5.5, 5.7 to 5.9, 5.13, and 5.14</a> <a href="#">Sections 5.1, 5.2, 5.4, 5.5, 5.7 to 5.9, 5.13, and 5.14</a>

\* Reference section for acceleration measurement.

# Flow of Operation

The figure below provides an overview of the flow of operations described in this manual. For a description of each item, see the relevant chapter or section.

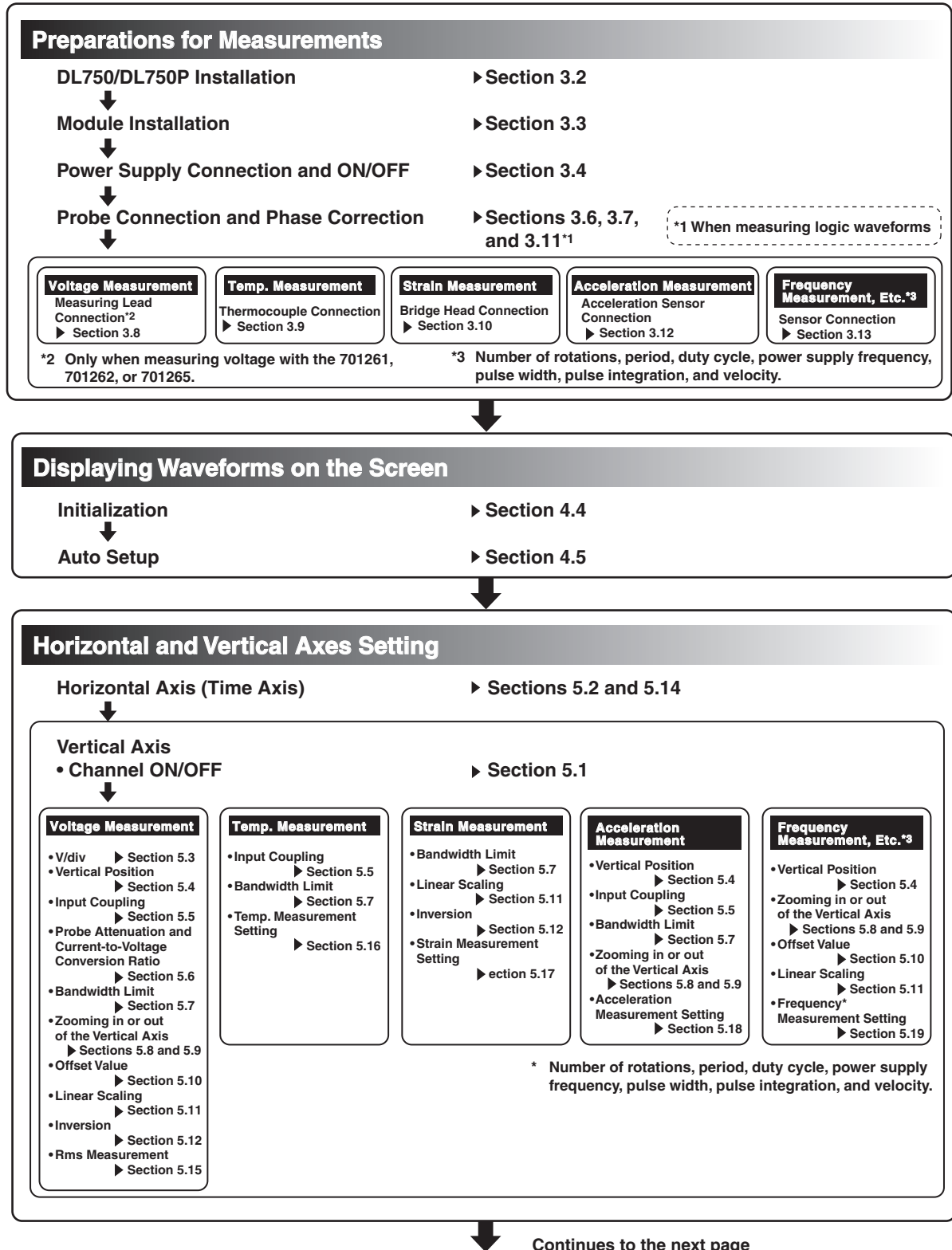

From the previous page

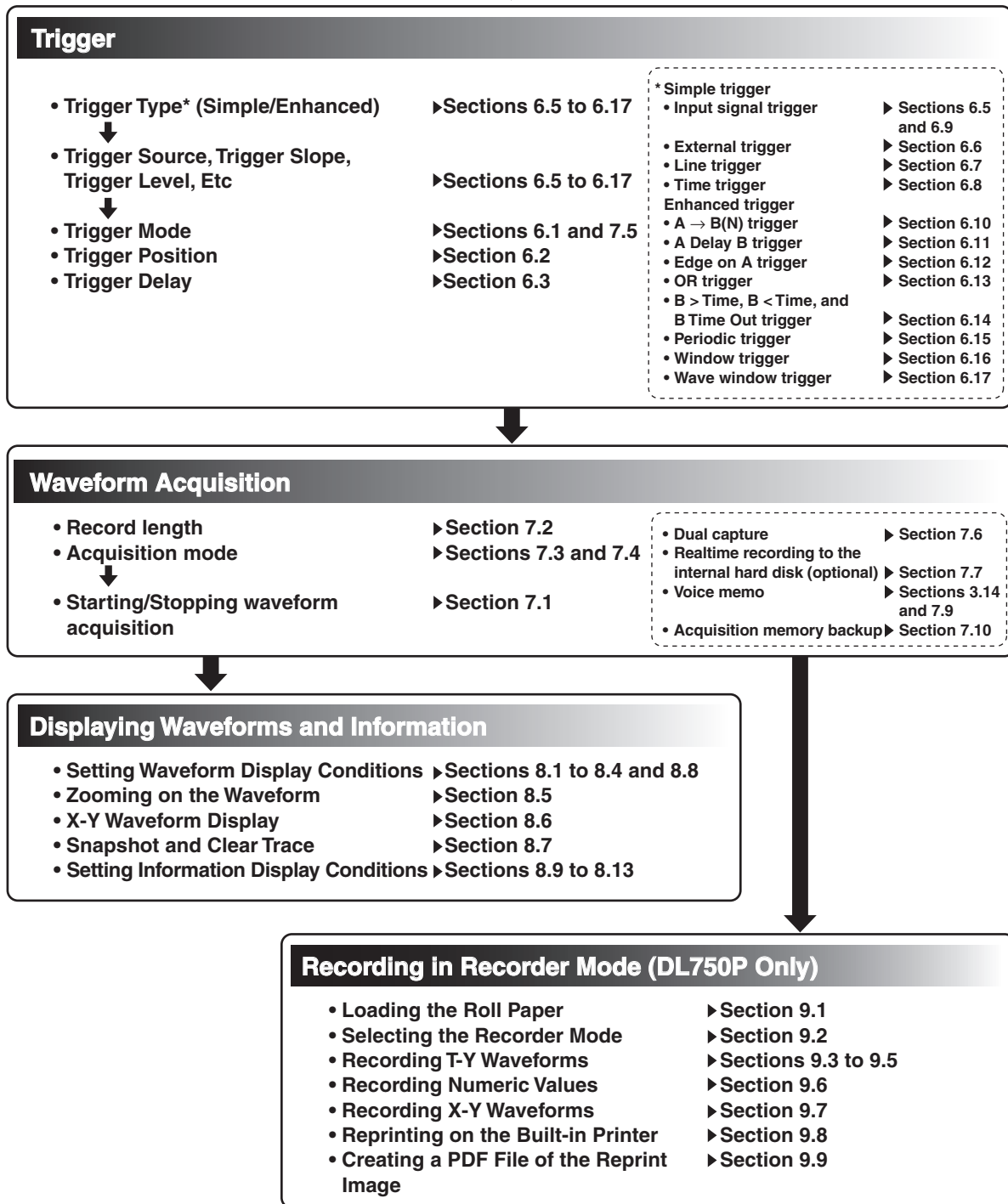

The functions below that are not covered in the flow of operations in this section are not explained in this manual. For their descriptions, see the User's Manual Part 2 (IM701210-06E).

- Computation, analysis, and searching of waveforms
- Printing of screen image data
- Saving and loading of data
- External trigger I/O, external clock input, video signal output, etc.
- DSP channels (option)
- Ethernet communications (option)

# 1.1 Top Panel, Front Panel, Right Side Panel, and Left Side Panel

## Top Panel

### DL750

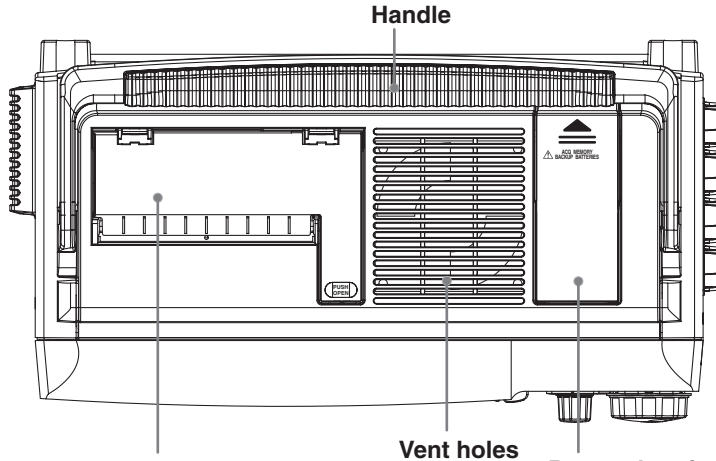

**Built-in printer**

Prints the displayed information.  
For the procedure in setting the roll paper, see section 12.1.  
For the printout procedure, see section 12.2.

**Vent holes**

**Battery box for memory backup**

Stores batteries used to back up the contents of the acquisition memory when the power is OFF.  
For the procedure in installing the batteries, see section 7.10.

### DL750P

**Built-in printer**

Prints the displayed information.  
For the procedure in setting the roll paper, see section 9.1.  
For the printout procedure, see section 12.2.

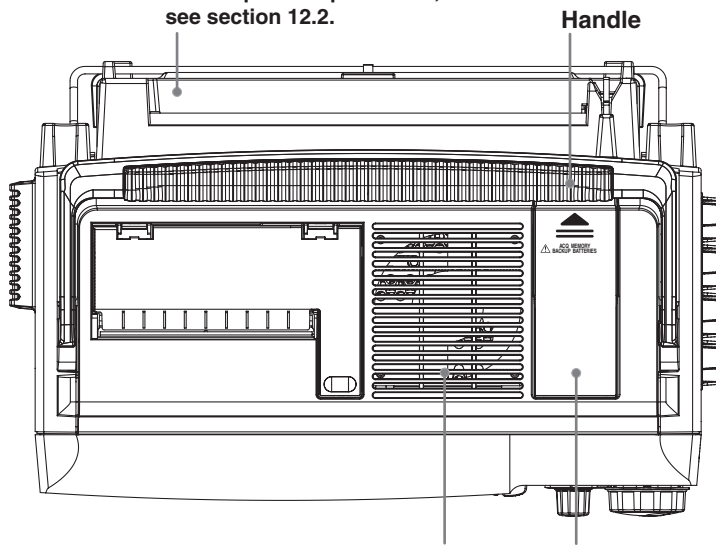

**Handle**

**Vent holes**

**Battery box for memory backup**

Front Panel

**DL750**

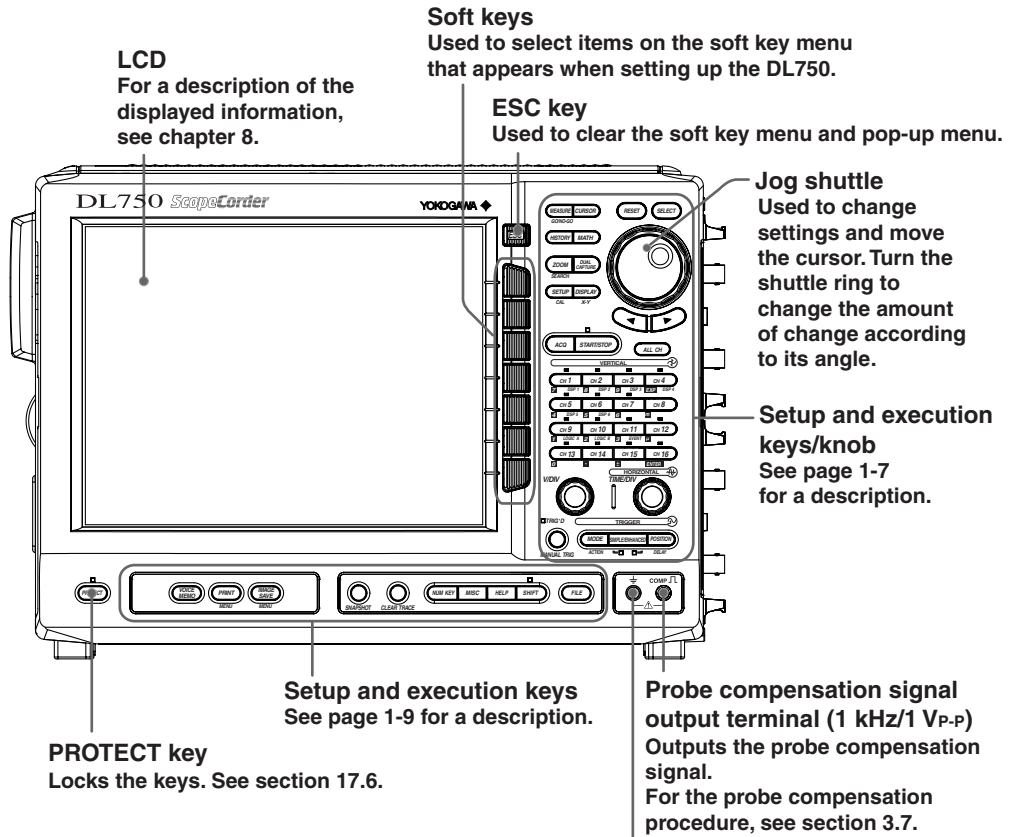

**DL750P**

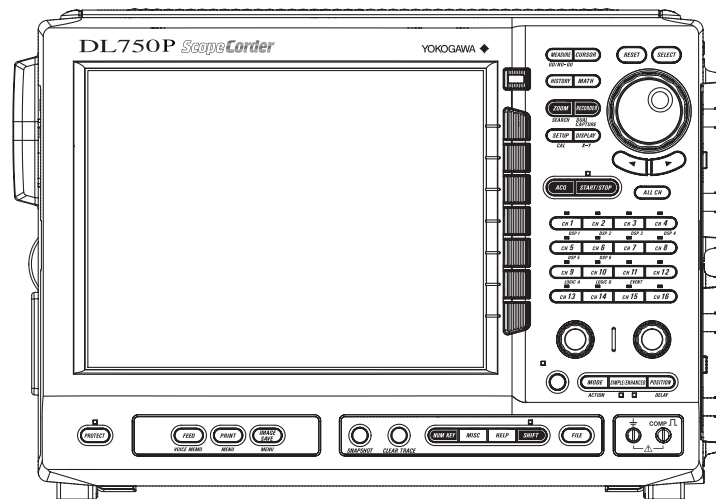

The name and function of each part are the same as the DL750.

Right Side Panel

**DL750**

**Acquisition memory backup ON/OFF**

Turns ON/OFF the battery power for backing up the acquisition memory.

For a description of the acquisition memory backup function, see section 7.10.

**Input module installation slot**

Eight slots on each row, top and bottom.

For the installation and removal procedure of the input module, see section 3.3.

**Input channel arrangement**

○ CH1	○ CH3	○ CH5	○ CH7
○ CH2	○ CH4	○ CH6	○ CH8
○ CH9	○ CH11	○ CH13	○ CH15
○ CH10	○ CH12	○ CH14	○ CH16

**Functional ground terminal**

Used to connect the ground line from the high-voltage differential probe or when enhancing the grounding of the measurement system. For the probe connection procedure, see section 3.6.

**Probe power supply terminal**

Used to supply power ( $\pm 12$  V) to the probes when using current probes. For the probe connection procedure, see section 3.6.

**Stand**

For the setup procedure, see section 3.2.

**Empty slot protection cover**  
Attached to the slots that are not used.

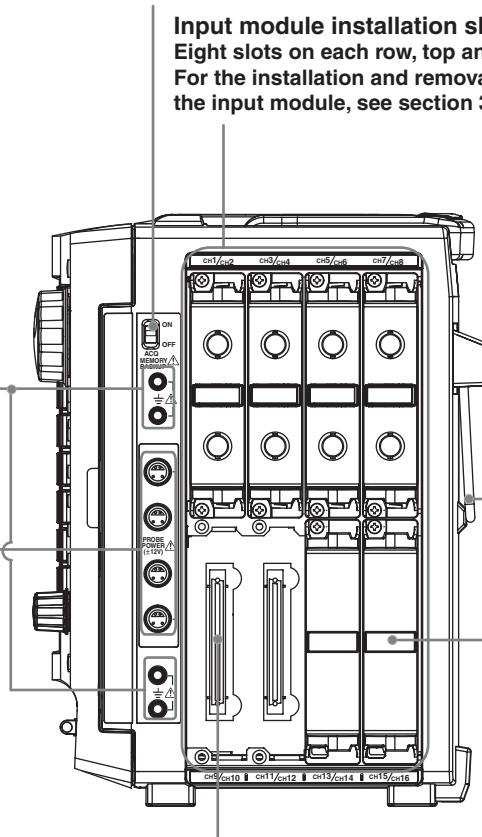

**Input module connector**

**DL750P**

**Input channel arrangement**

○ CH1	○ CH3	○ CH5	○ CH7
○ CH2	○ CH4	○ CH6	○ CH8
○ CH9	○ CH11	○ CH13	○ CH15
○ CH10	○ CH12	○ CH14	○ CH16

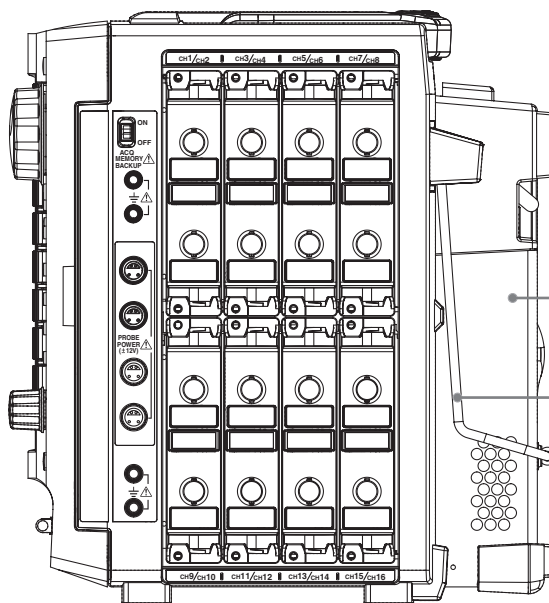

**Built-in printer**

**Stand**

The name and function of each part are the same as the DL750.

## 1.1 Top Panel, Front Panel, Right Side Panel, and Left Side Panel

### Input Module

The following 11 input modules are available.

**High-Speed 10 MS/s, 12-Bit Isolation Module**  
HS10M12 (model: 701250)

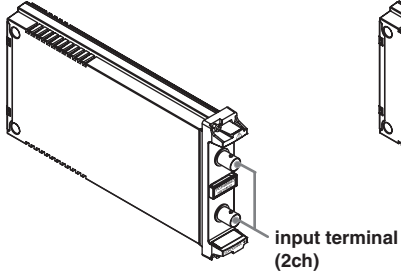

**701251 High-Speed High-Resolution 1 MS/s, 16-Bit Isolation Module**  
HS1M16 (model: 701251)

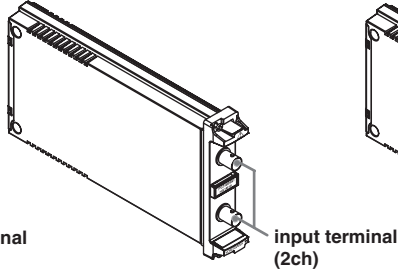

**High-Speed 10 MS/s, 12-Bit Non-Isolation Module**  
NONISO\_10M12 (model: 701255)

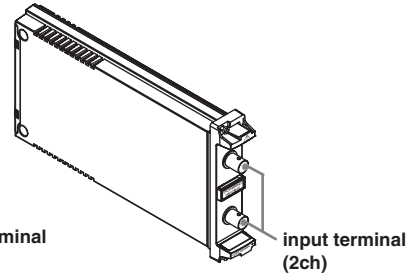

**High-Voltage 100kS/s, 16-Bit Isolation Module (with RMS)**  
HV (with RMS) (model: 701260)

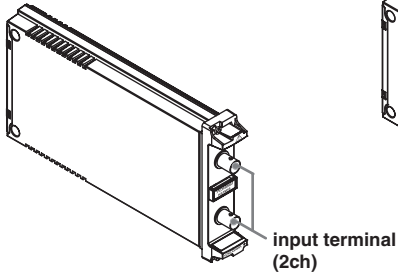

**Universal (Voltage/Temp.) Module**  
UNIVERSAL (model: 701261)

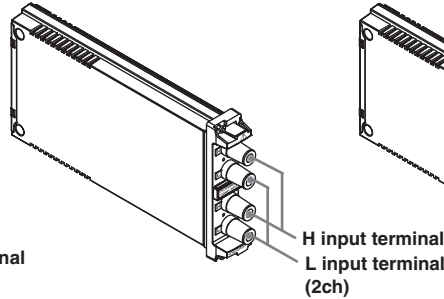

**Universal (Voltage/Temp.) Module (with AAF)**  
UNIVERSAL (AAF) (model: 701262)

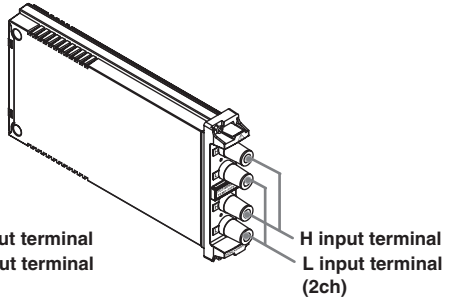

**Temperature, High Precision Voltage Isolation Module**  
TEMP/HPV (model: 701265)

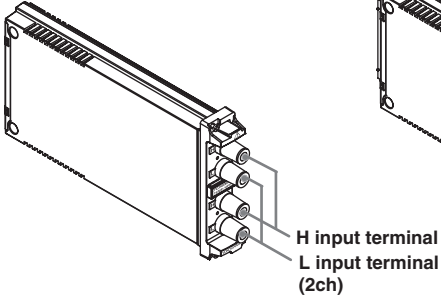

**Strain Module (NDIS)**  
STRAIN\_NDIS (model: 701270)

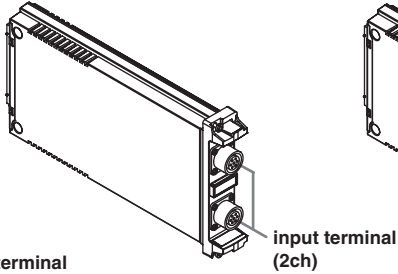

**Strain Module (DSUB, Shunt-Cal)**  
STRAIN\_DSUB (model: 701271)

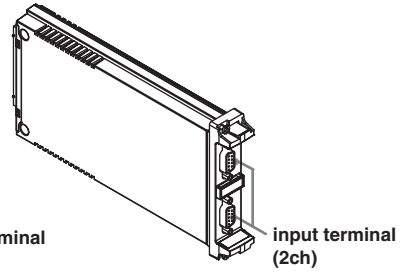

**Acceleration/Voltage Module (with AAF)**  
ACCL/VOLT (model: 701275)

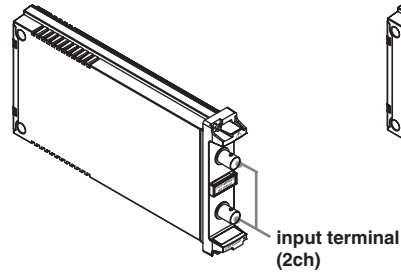

**Frequency Module**  
FREQ (model: 701280)

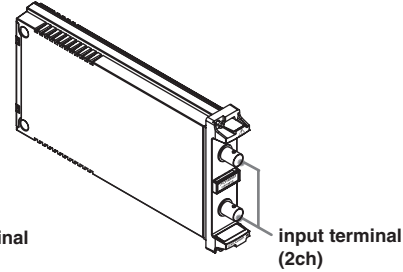

Left Side Panel

DL750

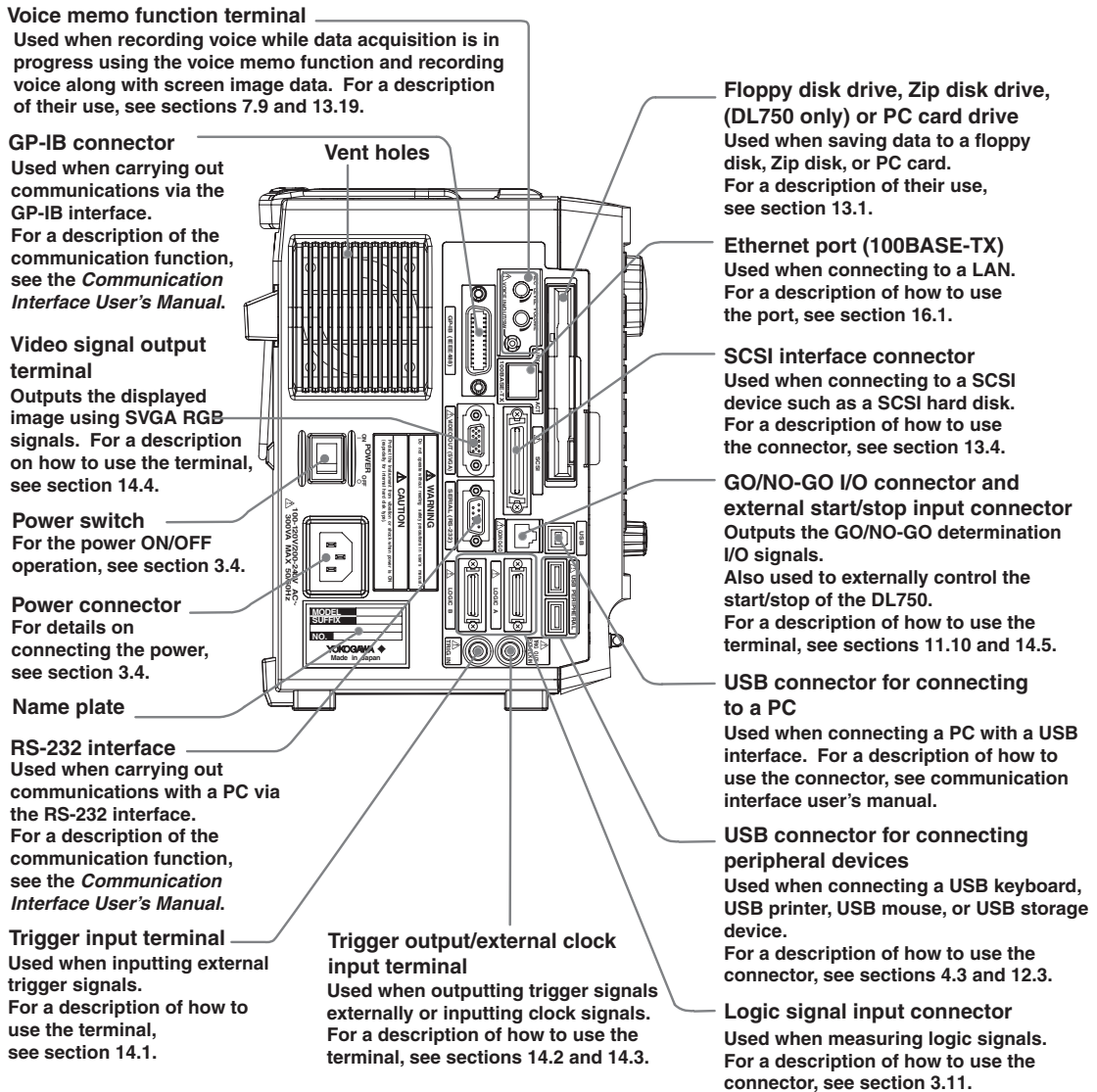

DC Power Supply Model (DL750 only)

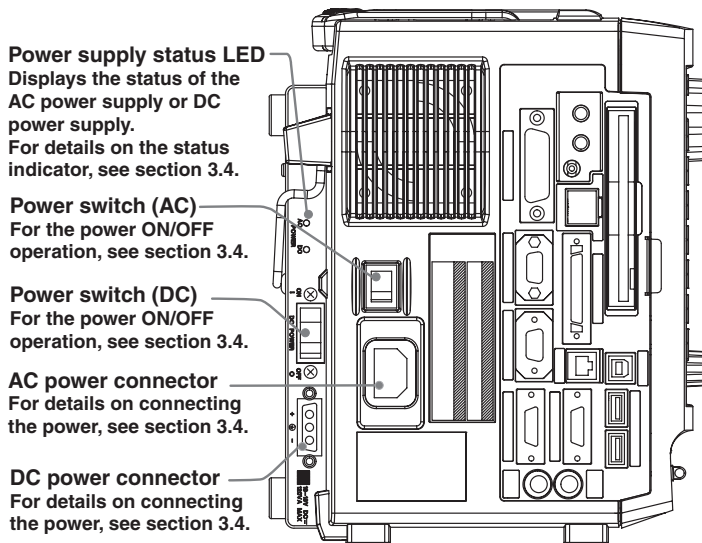



## 1.1 Top Panel, Front Panel, Right Side Panel, and Left Side Panel

---

### DL750P

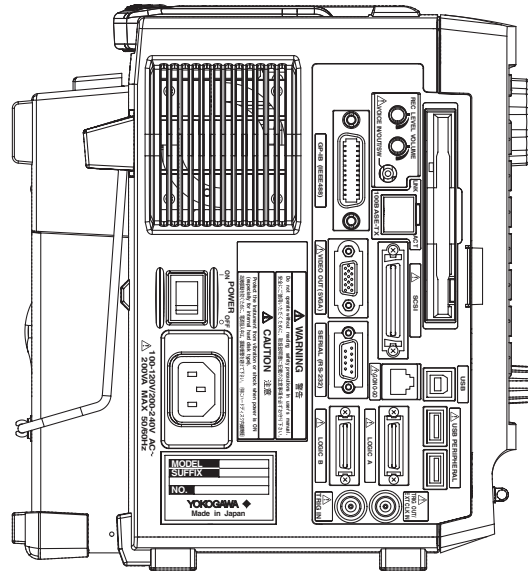

The name and function of each part are the same as the DL750.

## 1.2 Panel Keys and Knobs

### VERTICAL/HORIZONTAL Group Keys and Knobs

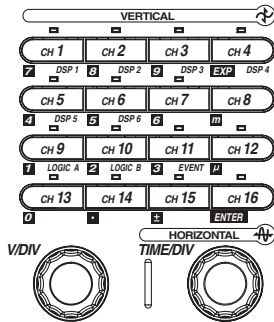

- **CH1 to CH16 Keys (Chapter 5)**

Displays a menu used to turn ON/OFF the display of each channel and set the vertical position, coupling, probe type, offset voltage, bandwidth limit, expansion or reduction of the vertical axis, linear scaling, and waveform labels. In addition, by pressing this key before operating the V/DIV knob, the channel that is to be controlled by the V/DIV knob can be selected. The indicator above each CH key illuminates when the corresponding channel is ON.

In addition, pressing the SHIFT key followed by a CH key displays a menu corresponding to the purple characters marked below and to the right of each key. (CH1 to CH6: DSP1 to DPS6, CH9: LOGIC A, CH10: LOGIC B, CH11: EVENT) Pressing the NUM KEY (see page 1-9) followed by a CH key causes the gray value marked below and to the left of each key to be entered.

- **V/DIV Knob (Section 5.3)**

You can set the voltage sensitivity using this knob. Before turning this knob, you press a key from CH1 to CH16 to select the target channel. If you change the setting while the waveform acquisition is stopped, the setting takes effect when you restart the waveform acquisition.

If you select a DSP channel (optional) by pressing the SHIFT key followed by one of the CH1 to CH6 keys before turning this knob, you can change the Value/Div setting of the DSP channel.

- **TIME/DIV Knob (Section 5.2)**

This knob is used to set the time axis scale. If you change the setting while the waveform acquisition is stopped, the setting takes effect when you restart the waveform acquisition.

### TRIGGER Group Keys

**TRIG'D indicator**  
Illuminates when a trigger is activated.

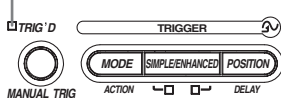

- **MANUAL TRIG Key (Section 6.19)**

Press the key to forcibly activate a trigger.

- **(SHIFT+) MODE Key (Sections 6.1 and 6.18)**

Displays a menu used to select the trigger mode. Pressing the SHIFT key followed by the MODE key displays a menu related to action-on-trigger or action-on-log-end.

- **SIMPLE/ENHANCED Key (Sections 6.4 to 6.17)**

Displays a trigger setup menu. If the indicator below and to the left of the key is illuminated, simple trigger is enabled; if the indicator below and to the right of the key is illuminated, enhanced trigger is enabled.

- **(SHIFT+) POSITION Key (Sections 6.2 and 6.3)**

Sets the trigger position. Pressing the SHIFT key followed by the POSITION key allows you to set the trigger delay.

Other Keys

DL750

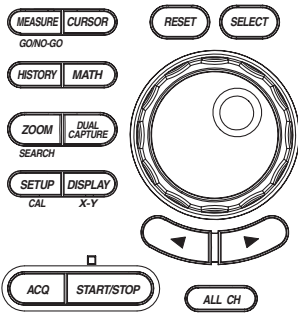

DL750P

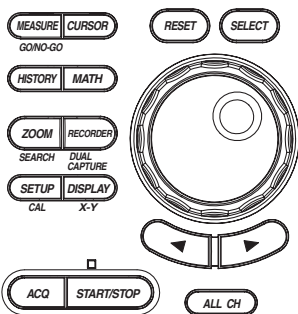

- **(SHIFT+) MEASURE Key (Sections 11.6 and 11.7)**  
Displays a menu used when performing automated measurement of waveform parameters. Pressing the SHIFT key followed by the MEASURE key displays a menu related to GO/NO-GO determination.
- **CURSOR Key (Section 11.5)**  
Displays a menu used when performing cursor measurements.
- **HISTORY Key (Sections 11.1 to 11.3)**  
Displays a menu used to recall data using the history memory function.
- **MATH Key (Sections 10.1 to 10.5)**  
Displays a menu used when performing waveform computation.
- **(SHIFT+) ZOOM Key (Sections 8.5 and 11.4)**  
Displays a menu related to the zoom display of waveforms. Pressing the SHIFT key followed by the ZOOM key displays a menu related to data search (search & zoom function).
- **DUAL CAPTURE Key (Section 7.6)**  
Displays a menu related to the dual capture function.
- **RECORDER Key (Chapter 9)**  
Available only on the DL750P. Displays a menu related to the recorder mode.
- **(SHIFT+) SETUP Key (Sections 4.4 to 4.6)**  
Displays a menu used to initialize the settings to factory defaults, perform auto setup, which automatically sets the DL750/DL750P according to the input signal, store or recall setting parameters, and so on. Pressing the SHIFT key followed by the SETUP key displays a menu related to calibration.
- **(SHIFT+) DISPLAY Key (Sections 8.1 to 8.4, 8.6, 8.8 to 8.13)**  
Displays a menu related to the screen display. Pressing the SHIFT key followed by the DISPLAY key displays a menu related to the X-Y display.
- **ACQ Key (Sections 5.14, 7.2 to 7.4, and 7.7)**  
Displays a menu used to set the waveform acquisition mode.
- **START/STOP Key (Section 7.1)**  
Starts/Stops waveform acquisition according to the trigger mode. Waveform acquisition is in progress when the indicator above the key is illuminated.
- **ALL CH Key (Section 5.13)**  
Displays a pop-up window containing a list of settings similar to those displayed on the menu when one of the CH1 to CH16 or DSP1 to DSP6 (optional) keys is pressed.
- **RESET Key**  
Resets the value to the initial value.
- **SELECT Key**  
Confirms the menu item that you selected using the jog shuttle.
- **Arrow Keys (◀▶ Keys)**  
Moves the numeric entry digit (cursor) left or right.

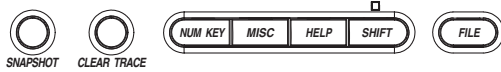

- **SNAP SHOT Key (Section 8.7)**  
Leaves the current displayed waveform on the screen in black and white. Waveforms acquired using the snap shot function can be saved and loaded.
- **CLEAR TRACE Key (Section 8.7)**  
Clears the waveform acquired using the snap shot function and accumulated waveforms.
- **NUM KEY Key (Section 4.2)**  
Press this key to use the CH1 to CH16 keys as number input keys.
- **MISC Key (Sections 3.5, 13.6, 16.2 to 16.10, 17.1 to 17.5)**  
Displays menus for setting the communication interface, setting the environment, checking the system status, setting the SCSI ID number, accessing the self-diagnostic function, turning ON/OFF the LCD backlight, etc.
- **HELP Key (Section 4.7)**  
Turns ON/OFF the help window that provides description about the procedure.
- **SHIFT Key**  
Pressing the key once causes the indicator above the key to illuminate and activate the function marked below the key in purple. Pressing the key again clears the shifted condition.
- **FILE Key (Sections 13.5, 13.7 to 13.12, 13.14 to 13.17, and 16.3)**  
Displays a menu used to save various data to, recall various data, or execute file operations on a storage medium such as a floppy disk, zip disk, PC card, external SCSI device (option).

**Note**

Pressing the SHIFT key followed by the CLEAR TRACE key clears the remote mode using the communication interface. For details, see the *Communication Interface User's Manual* (IM 701210-18E).

**DL750****DL750P**

- **PROTECT Key (Section 17.6)**  
Pressing this key causes the LED above the key to illuminate, and the front panel keys to be disabled. Pressing the key again clears the condition.
- **VOICE MEMO Key (Section 7.9)**  
Displays a menu related to the voice memo function.  
On the DL750P, (SHIFT+)FEED key is used to display the VOICE MEMO menu.
- **FEED Key (Section 9.1)**  
Available only on the DL750P. Pressing this key feeds the paper on the built-in printer.
- **(SHIFT+) PRINT Key (Sections 12.2 to 12.4, and 16.4)**  
Executes the printing of the screen image data. Pressing the SHIFT key followed by the PRINT key displays a menu used when printing the screen image to the internal printer, USB printer, or network printer.
- **(SHIFT+) IMAGE SAVE Key (Sections 13.11, 13.12, and 16.3)**  
Stores the screen image data to the storage medium. Pressing the SHIFT key followed by the IMAGE SAVE key displays a menu related to the saving of the screen image data.

# 1.3 Display Screens

## Normal Waveform Display

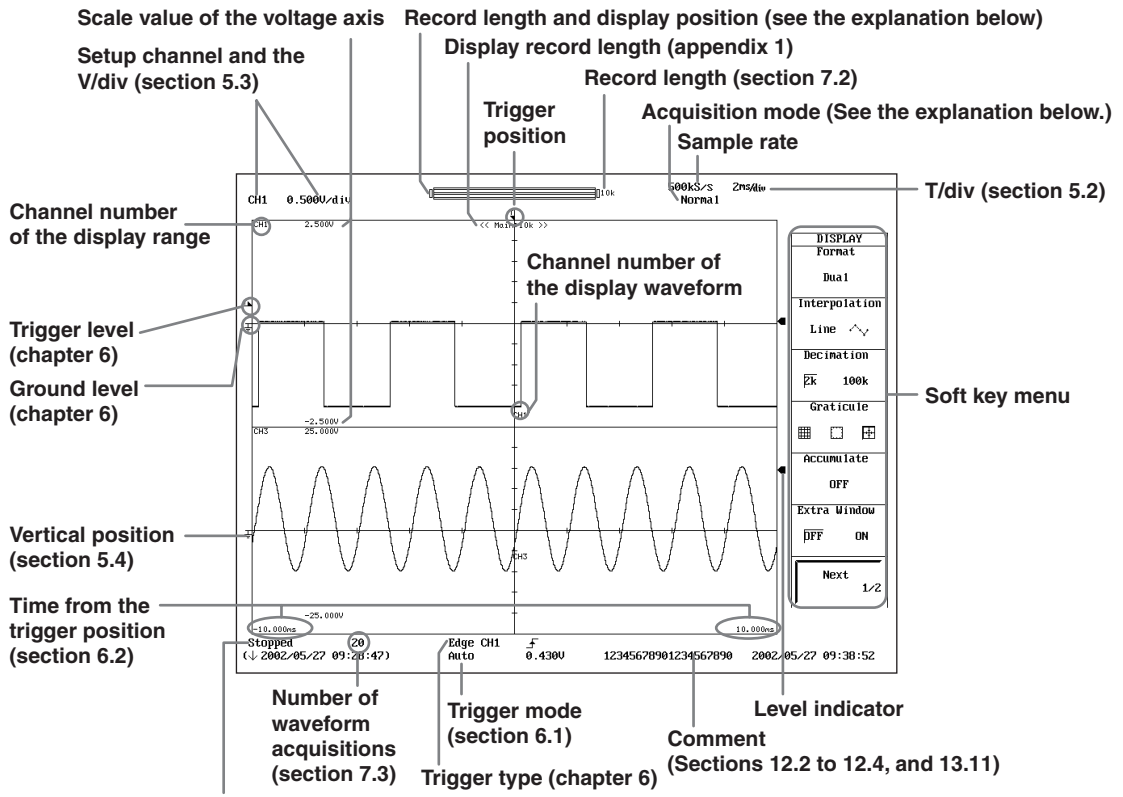

**Waveform acquisition condition**  
 Stopped                      Pre...: Acquiring pre data  
 Running                      Post...: Acquiring post data  
 Waiting for trigger  
 HD out: Continuous writing to hard disk

### Displaying the Record Length and Display Position

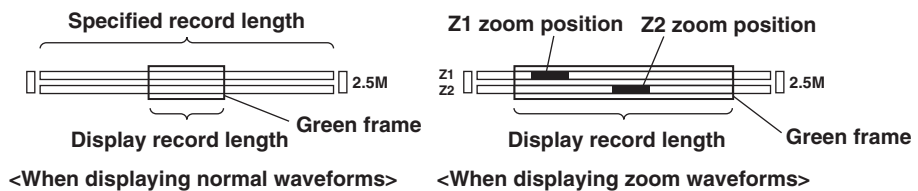

### Acquisition Mode Indication

- Normal: Normal mode
- Env: Envelope mode
- Avg: Average mode
- BoxAvg: Box average mode

### Note

In some cases, the LCD on the DL750/DL750P may include few defective pixels. For details, see section 19.4, "Display."

Zoom Waveform Display

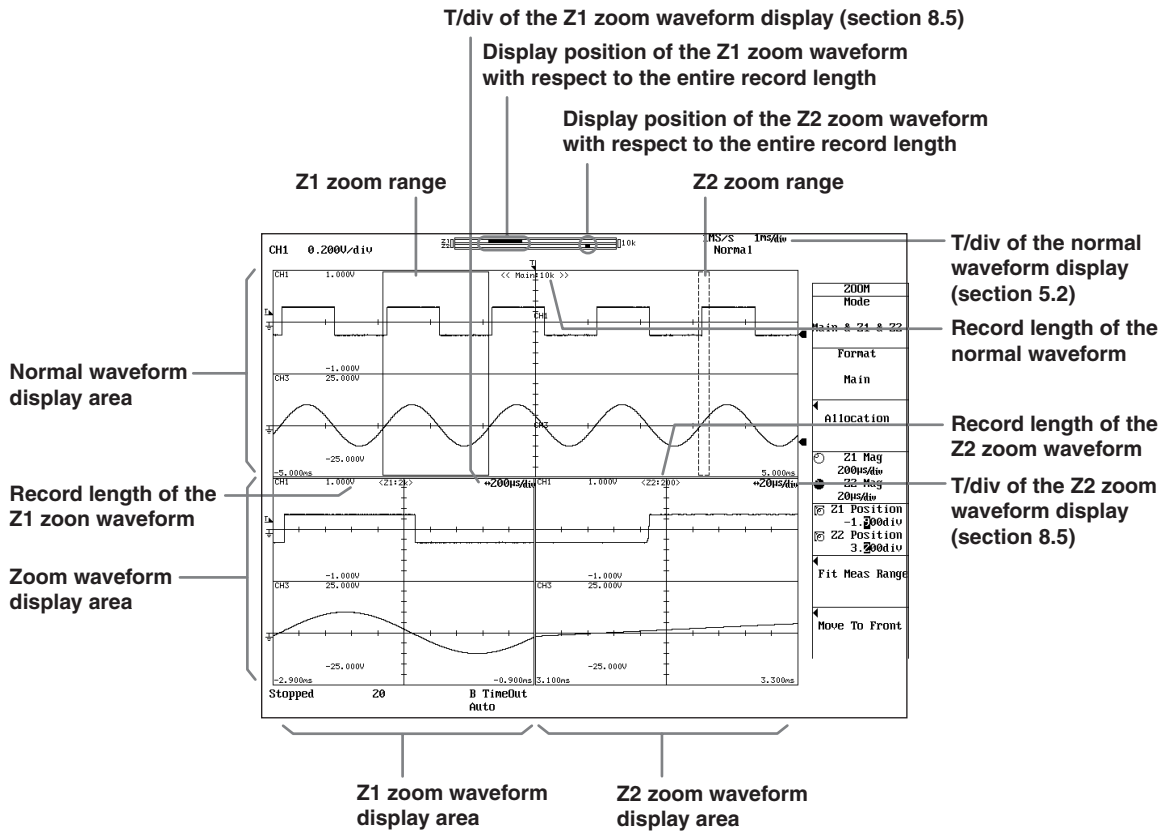

Dual Capture Display

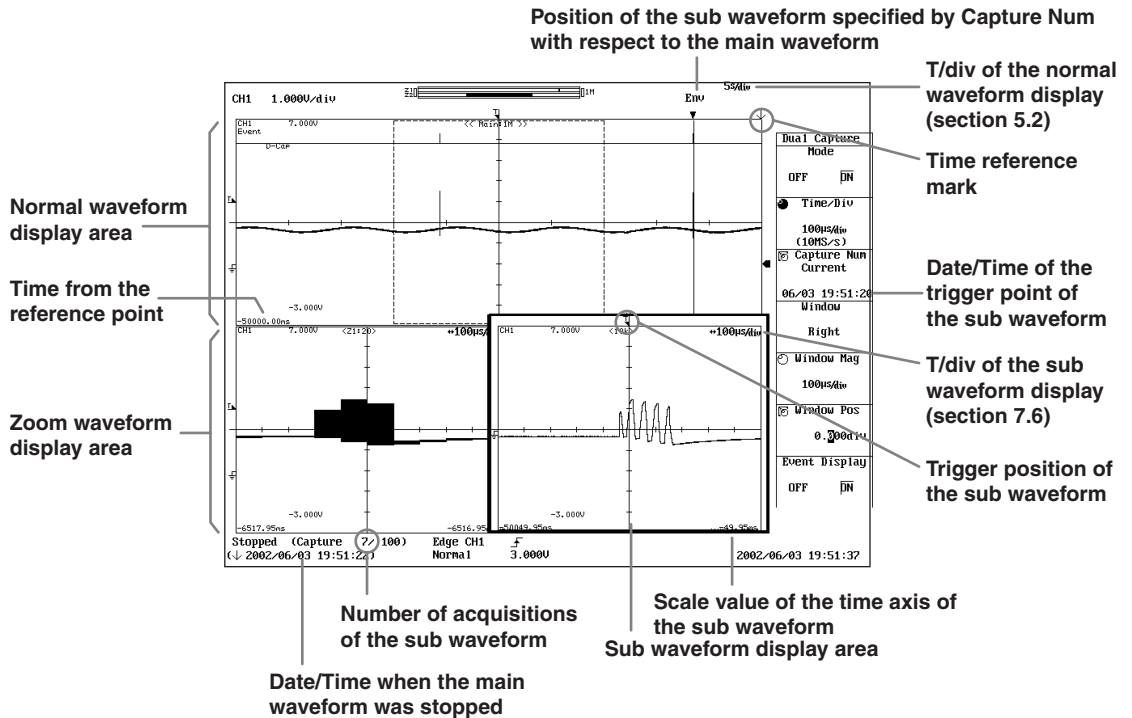

## 2.1 System Configuration/Block Diagram

### System Configuration

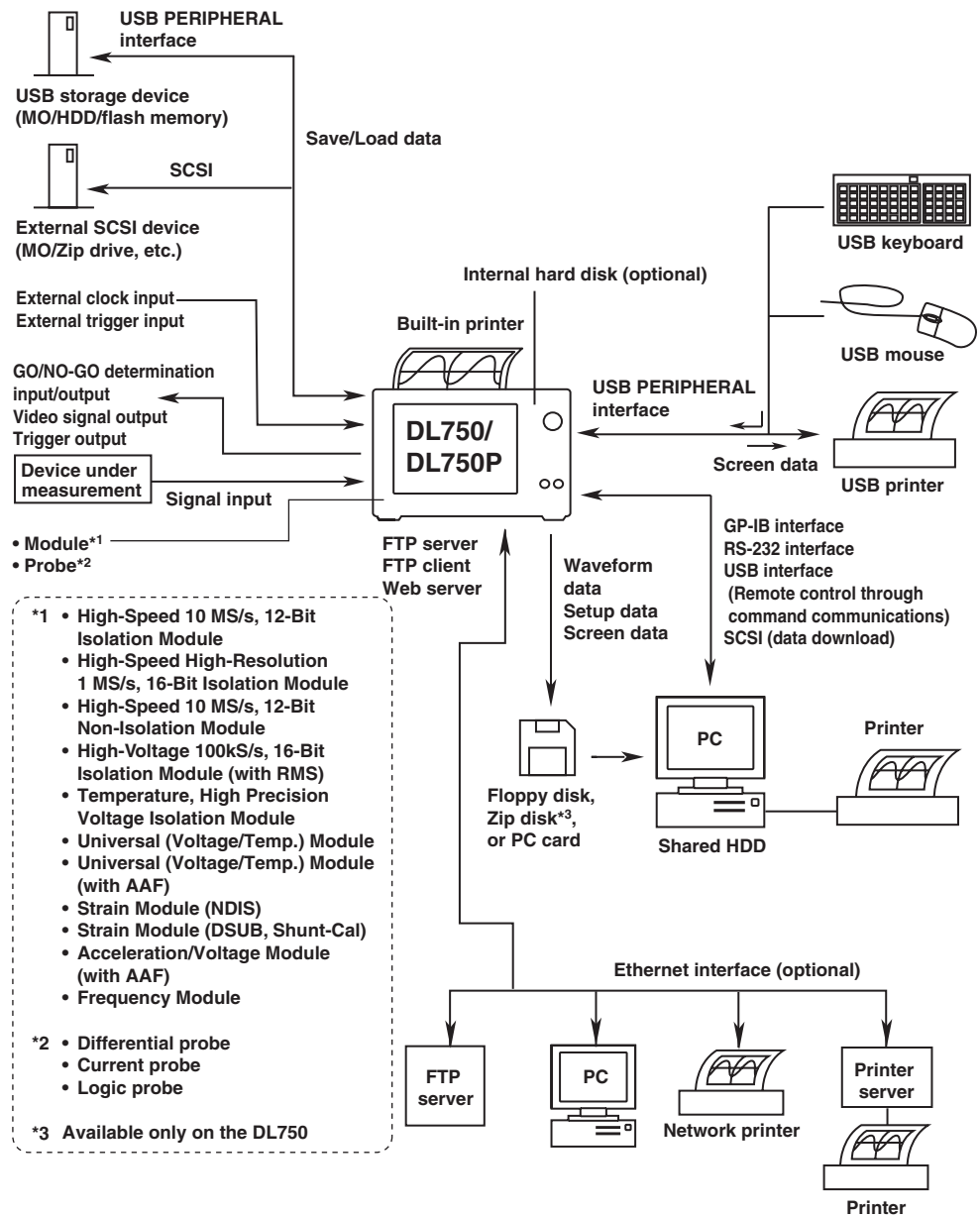

## 2.1 System Configuration/Block Diagram

### Block Diagram of the DL750/DL750P

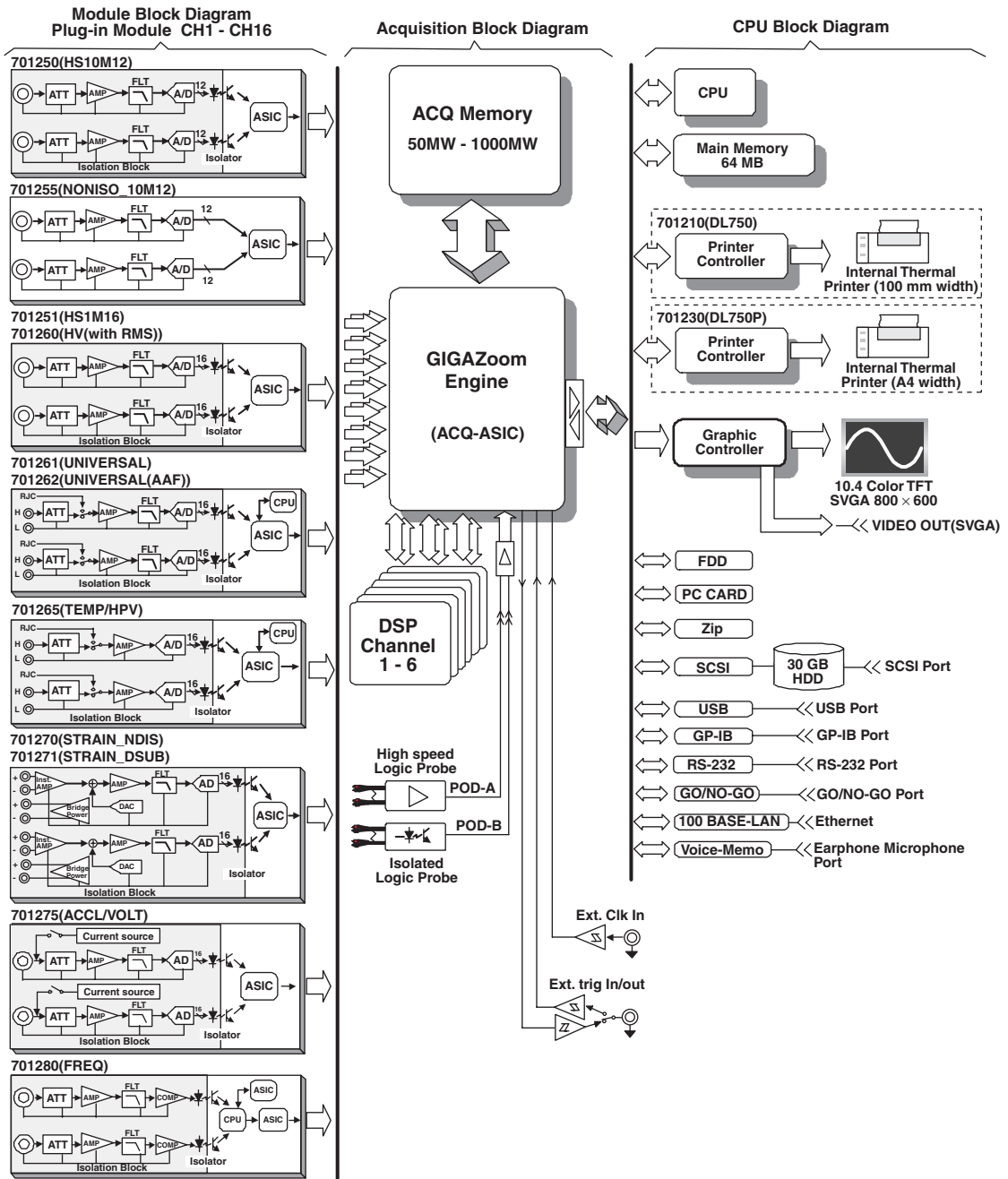

#### Signal Flow on the DL750/DL750P

The flow of the signal applied to the input signal varies depending on the module. Here, the High-Speed 10 MS/s, 12-Bit Isolation Module (HS10M12(701250)) is used as an example for the explanation. (For details on the flow of the signal of each module, see the block diagram.)

The signal applied to the two input terminals is first processed by the input section of each module.

On the HS10M12(701250), the input signal is attenuated/amplified by the attenuator and amplifier and its bandwidth is limited using the filter. The signal is then A/D converted, passed through the isolator and ASIC, and output to the main unit.

At the A/D converter, the input signal is sampled at a sample rate of 10 MS/s (10 million times per second) and converted to digital data.

The 16 channels of digital data collected at the CPU board pass through the GIGAZoom Engine (ACQ-ASIC) and stored in the ACQ Memory. The digital data stored in the ACQ Memory is compressed at high speeds by the GIGAZoom Engine (ACQ-ASIC), passed through the Graphic controller, and displayed on the SVGA TFT color display.

The DSP channel (optional) performs realtime computation between arbitrary channels using the A/D conversion data of an analog input channel (or the computed result of a DSP channel) as a computation source. Using DSP channels, the DL750/DL750P can acquire waveforms of up to 16 channels + 6 DSP channels + 16-bit digital data, simultaneously.



## 2.2 Setting the Horizontal and Vertical Axes

### Horizontal Axis <Section 4.2>

#### Setting the Time Axis

When using the internal clock<sup>1</sup>, the time axis is set in terms of the time per one grid square (1 div). The selectable range is 500 ns/div to 30 s/div, 1 min/div to 30 min/div, 1 hour/div to 12 hour/div, and 1 day/div to 3 day/div. The transition between seconds, minutes, hours, and day is automatically performed. Since the display span along the horizontal axis is 10 divisions, the time span of the displayed waveform is equal to “the time axis setting  $\times$  10.”

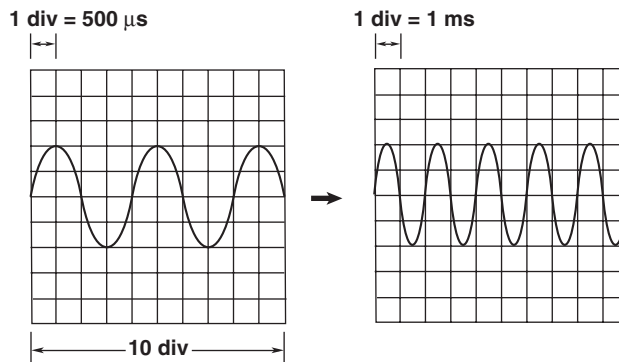

#### 1. Internal clock and external clock (time base selection)

Under the initial setting, the sampling timing of waveform data is controlled by the clock signal generated from the time base circuit within the DL750/DL750P (see section 1.3).

The timing can also be controlled by a clock signal applied externally. External clock signals are input through the external clock input terminal on the left panel facing the DL750/DL750P. This external clock input is useful for observing a signal whose period varies or for observing waveforms by synchronizing to the clock signal of the signal being measured.

#### Display in the Time Axis Direction

There are 10 divisions along the time axis, and 1001 points (logical number of points, not the dots on the screen) are used to draw the waveforms. Therefore, if the display record length (see page 2-31) is exactly 1 kW (the number of acquired data points is 1001), the waveform is displayed using 1001 points. However, if the display record length is greater than or equal to 2 kW, the maximum and minimum values are determined (P-P compression) and aligned at the same time position (total number of points: 2002) to draw the waveform.

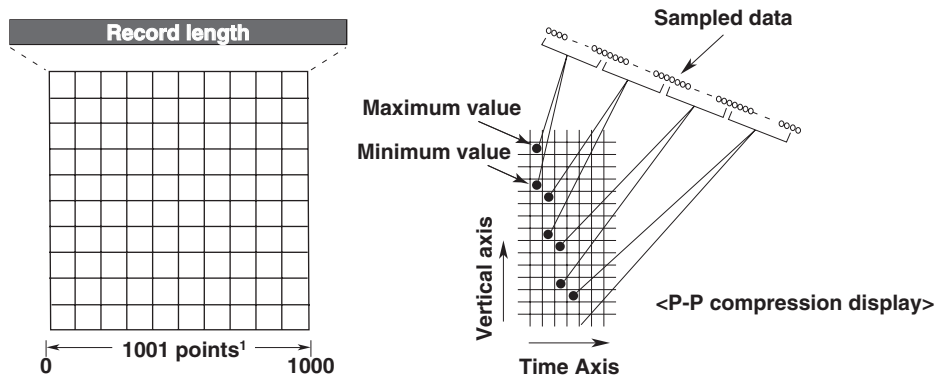

1. 1001 points is a logical number of points. On the screen the data is compressed to 651 dots (751 dots when the zoom waveform area is expanded) and displayed.

- **Zooming Horizontally and Drawing Waveforms**

The DL750/DL750P is capable of expanding (zooming) the waveform horizontally (see page 2-41). When the zoom rate of the waveform is increased, the number of displayed points decreases. The waveform is displayed P-P compressed until the number of display points falls to 2002 points. When the number of displayed points falls below 1001, the waveform can no longer be displayed using continuous lines. In this case, the display data is interpolated using the display interpolation function (see page 2-37) so that the number of displayed points is 1001 points.

- **Dot Display**

By default, the display interpolation function works automatically. However, you can also disable the display interpolation in which case the waveform is displayed using dots. In this setting, up to 2002 points or 100100 points (select either 2 k or 100 k points) of the acquired data are displayed without using P-P compression. For example, if the number of displayed points is set to 100 k and the display record length is 10 kW (the number of acquired data points is 10010 points), all the points of the waveform are drawn by aligning 10 points vertically at the same time axis positions. If the number of acquired data points exceeds 2002 or 100100, the data is decimated down to 2002 or 100100 points (select either 2 k or 100 k points) for displaying the waveform.

### Relationship between the Time Axis Setting and Sample Rate/Record Length

If you change the time axis setting, the sample rate and the record length acquired to the acquisition memory also change. For details, see appendix 1, "Relationship between the Time Axis Setting, Sample Rate and Record Length."

### Sample Rate

If you change the time axis setting, the sample rate (the maximum sample rate varies depending on the module) changes. The DL750/DL750P can only display waveforms correctly up to one-half the frequency of the sample rate (the number of samples per second, unit is S/s) as defined by the Nyquist sampling theorem.<sup>1</sup>

1. If the sample rate is comparatively low with respect to the input signal frequency, the harmonics contained in the signal are lost. In this case, some of the harmonics will appear at low frequencies due to the effects described by the Nyquist sampling theorem. This phenomenon is called aliasing. You can prevent aliasing by acquiring waveforms with the acquisition mode set to envelope.

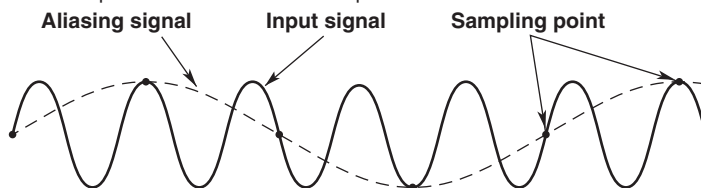

### Time Axis Setting and Roll Mode Display

If the trigger mode is set to Auto, Auto Level, Single, or Log and the time axis is set greater than or equal to 100 ms/div, the waveform is displayed in roll mode. In roll mode, the displayed waveform is not updated using triggers (update mode). Rather, the oldest data is deleted as new data is acquired, and the waveform is shifted from right to left on the screen.

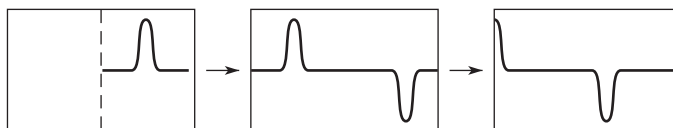

Roll mode display allows waveforms to be observed in the same way as on a pen recorder. It is useful in observing signals with a long period or signals that change slowly. It is also useful in detecting glitches (spikes in the waveform) that occur intermittently.

## Vertical Axis (Voltage Axis) <Section 5.3>

### Setting the Voltage Sensitivity

The vertical sensitivity setting is used to adjust the displayed amplitude of the waveform for easy viewing. The vertical sensitivity (V/div) is set by assigning a voltage value to one grid square (1 div) on the screen. The vertical sensitivity changes by switching the input section to an attenuator with different values of attenuation. The sensitivity is changed in steps as in "1 V/div to 2 V/div to 5 V/div."

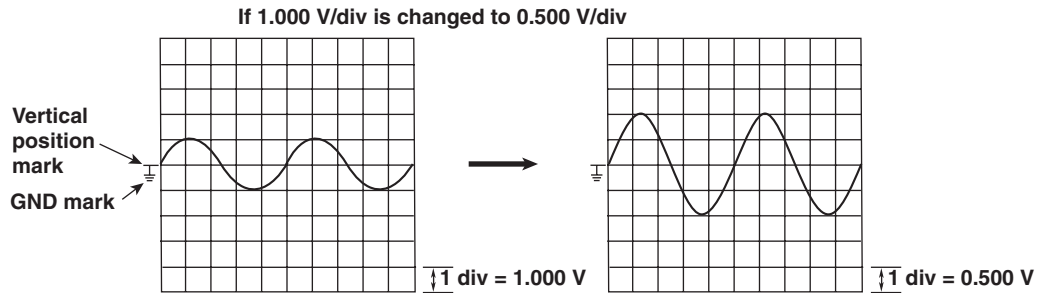

### Measurement Range and Display Range

The measurement range of the DL750/DL750P is  $\pm 10$  divisions (20 divisions of absolute width (span) around 0 V).

The display range of the screen is  $\pm 5$  divisions (10 divisions of span). The following functions can be used to move the displayed waveform and display the waveform outside the display range by expanding/reducing the displayed waveform.

- Move the vertical position -> See page 2-6.
- Set the offset voltage -> See page 2-6.
- Zoom in or out of the vertical axis (expand/reduce) -> See page 2-7.

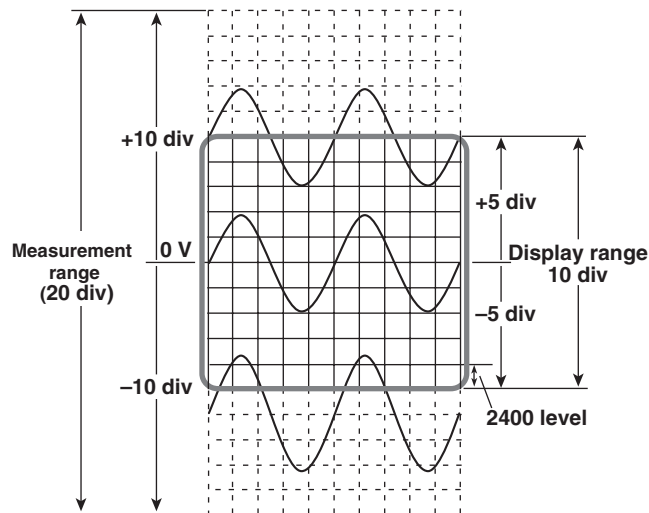

### Note

- **For Measuring the Voltage with High Accuracy**

To measure the voltage with high accuracy, set the voltage sensitivity so that the input signal is measured with as large amplitude as possible.

- **Measurement Resolution**

The measurement resolution varies depending on the module. For example, the 701250 (HS10M12) and 701255 (NONISO\_10M12) sample the input signal using a 12-bit A/D converter at a resolution of 150 levels per division. The 701251 (HS1M16), 701260 (HV (with RMS)), 701261 (UNIVERSAL), 701262 (UNIVERSAL (AAF)), 701265 (TEMP/HPV), and 701275 (ACCL/VOLT) sample the input signal using a 16-bit A/D converter at a resolution of 2400 levels per division.

**Moving the Vertical Position of Waveforms <Section 5.4>**

Since the DL750/DL750P can display the input waveforms of the analog input channels (CH1 to CH16), DSP channels (DSP1 to DSP6, optional), and computation channels (Math1 to Math8), the waveforms may overlap making them difficult to be observed. In this case, you can change the display position of waveforms along the vertical axis (vertical position) for easier viewing.

The vertical position can be moved within a range of  $\pm 5$  div.

The voltage sensitivity (V/div) switches around the vertical position mark.

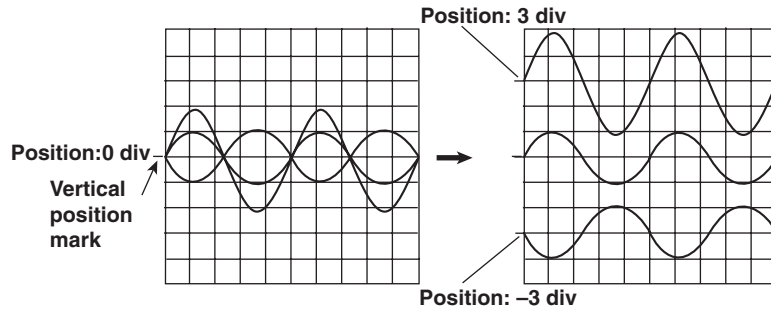

**Offset Value <Section 5.10>**

You can add an offset value to move the waveform to a vertical position that allows easier viewing. When observing a voltage riding on top of a predetermined voltage, an offset value can be applied to eliminate the predetermined voltage so that only the changes in the signal can be observed with higher voltage sensitivity.

The offset value does not affect the cursor measurement values, the result of the automated measurement of waveform parameters, and the computed values.

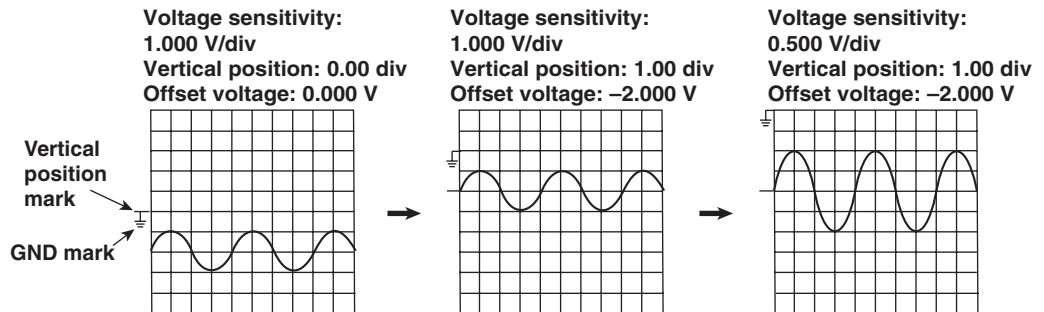

## Zooming in or out of the Vertical Axis (Expand/Reduce) <Sections 5.8 and 5.9>

### Zooming in or out by Setting the Magnification

The waveform display can be expanded/reduced vertically by a factor in the range  $\times 0.1$  to  $\times 100$  ( $\times 0.25$  to  $\times 100$  for 50 V/div,  $\times 0.5$  to  $\times 100$  for 100 V/div,  $\times 1$  to  $\times 100$  for 200 V/div on the 701260 (HV (with RMS)));  $\times 0.5$  to  $\times 50$  when measuring acceleration on the 701275 (ACCL/VOLT); and  $\times 0.33$  to  $\times 100$  on the 701280 (FREQ)). The waveform display can be zoomed around the vertical position. The waveform display can be zoomed around the vertical position.

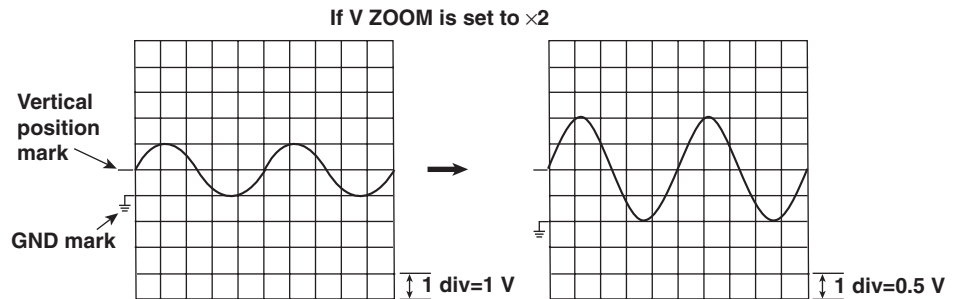

### Zooming Vertically According to the Upper and Lower Limits of the Display Range

You can zoom in on the desired section of the observed waveform by specifying the upper and lower limits of the vertical axis to change the display range to a narrower range for each displayed waveform. Conversely, you can widen the display range to view waveforms outside the display range.

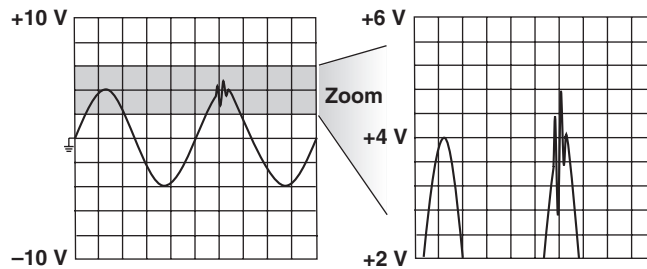

**Input Coupling <Section 5.5>**

If you wish to observe just the amplitude of an AC signal, it is best to remove the DC component from the input signal. On the other hand, there are times when you wish to check the ground level or observe the entire input signal (both the DC and AC components). In these cases, you change the input coupling setting. By changing the input coupling, the input method used to input the signal to the vertical control circuit (voltage axis) is switched.

Select from the following types of input coupling.

**DC**

The input signal is directly coupled to the attenuator of the vertical control circuit. Select DC when you wish to observe the entire input signal (DC and AC components).

**AC (Only When Observing the Voltage)**

The input signal is coupled to the attenuator of the vertical control circuit through a capacitor. Select AC when you wish to observe only the amplitude of the AC signal, eliminating the DC components from the input signal.

**GND**

Input signal is coupled to the ground not to the attenuator of the vertical control circuit. By selecting GND, you can check the ground level on the screen.

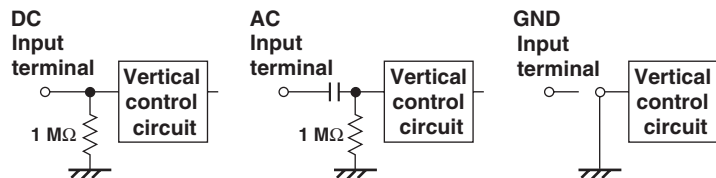

**TC (Only When Observing the Temperature)**

Select TC when observing the temperature on the 701261 (UNIVERSAL), 701262 (UNIVERSAL (AAF)), or 701265 (TEMP/HPV).

**DC-RMS**

Using the 701260 (HV (with RMS)), both the DC and AC components of the signal are converted to rms values and displayed. A RMS conversion circuit is connected to the vertical control circuit of the same input coupling circuit used when the coupling is set to “DC.”

**AC-RMS**

Using the 701260 (HV (with RMS)), only the AC component of the signal is converted to rms values and displayed. A RMS conversion circuit is connected to the vertical control circuit of the same input coupling circuit used when the coupling is set to “AC.”

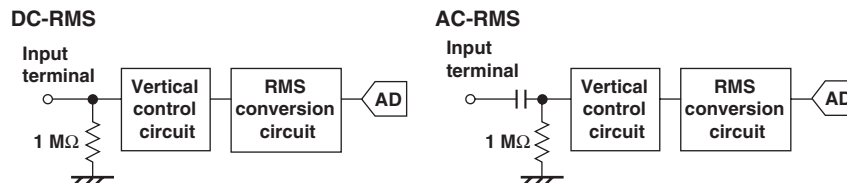

**ACCL (Only When Measuring Acceleration)**

Select ACCL when measuring acceleration on the 701275 (ACCL/VOLT).

**Probe Type <Section 5.6>**

For voltage (current) measurement, a probe is normally used in connecting the circuit being measured to the measurement input terminal. Using a probe has the following advantages.

- Prevents disturbing the voltage and current of the circuit being measured.
- Inputs the signal with no distortion.
- Expands the voltage range that can be measured by the DL750/DL750P.

When using a probe, the attenuation or current-to-voltage conversion ratio setting on the module must be set equal to the probe attenuation on the DL750/DL750P so that the measured voltage can be read directly.

The probe attenuation of each probe (accessory sold separately) is set as follows:

- Voltage probe (700929): 10:1
- Current probe (700937/701933): 10 A:1 V
- Current probe (701930/701931): 100 A:1 V
- Voltage differential probe (700924): 1000:1, 100:1
- 10:1 passive probe for the DL750/DL750P: 10:1

The DL750/DL750P has the following attenuation settings: 1:1, 10:1, 100:1, 1000:1, 10 A:1 V<sup>1</sup>, and 100 A :1 V<sup>2</sup>. If you are using a probe other than the ones provided as accessories (sold separately), set the attenuation ratio on the DL750/DL750P according to the attenuation of the probe.

1. Output voltage rate: 0.1 V/A
2. Output voltage rate: 0.01 V/A

**Note**

Use a probe that matches the input capacity of each module. Otherwise, the capacity cannot be adjusted.

**Bandwidth Limit <Section 5.7>**

The bandwidth can be limited on each module. By limiting the bandwidth, you can eliminate the noise components from the input signal for waveform observation.

**Linear Scaling <Section 5.11>**

When measuring the voltage (current), strain, or frequency (number of Rotations/period/ duty cycle/power supply frequency/pulse width/pulse integration/velocity) on the frequency module, there are two methods of linear scaling: "AX+B" and "P1-P2."

**AX+B**

The results obtained from the following computation based on the specified scaling coefficient A and offset B are displayed as cursor measurement values and automated measurement values of waveform parameters. You can also assign a unit to the result of linear scaling.  $Y=AX+B$

**P1-P2**

Specify arbitrary scale values (P1:Y and P2:Y) for the measured values of two arbitrary points (P1:X and P2:X). The scale conversion equation ( $y = ax + b$ ) is derived from these four values.

- Range of measured values (P1:X, P2:X): Same as the measurement range
- Range of scale values (P1:Y, P2:Y):  $-9.9999E+25$  to  $+9.9999E+25$
- Initial setting of scale values: P1:X  $+0.0000E+00$ , P1:Y  $+0.0000E+00$   
P2:X  $+1.0000E+00$ , P2:Y  $+1.0000E+00$

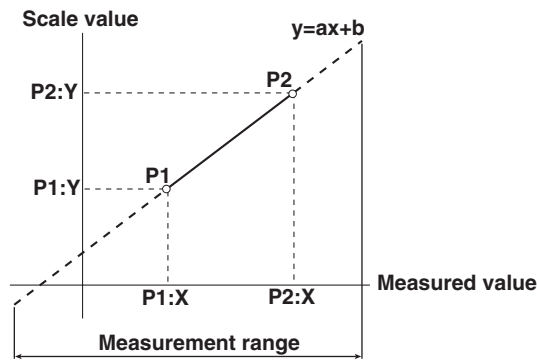

In addition, the current input value can be loaded into P1:X or P2:X.

**Inverted Display <Section 5.12>**

When measuring voltage or strain, the waveform can be displayed with the vertical axis inverted around the vertical position as shown below.

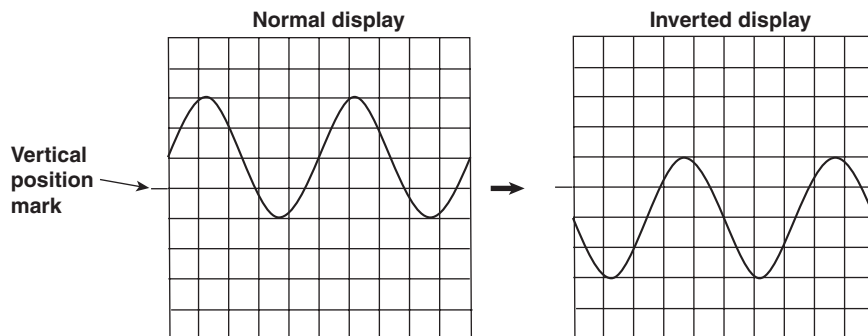



**Pulse/Rotate Function <Section 5.14>**

When the time base is set to external clock, one data sample is captured to the acquisition memory when one pulse of the external clock signal is input. You can specify the number of pulses of the external signal (in other words, the number of data samples captured in the acquisition memory) that will correspond to one mechanical rotation (one cycle). The selectable range is from 1 to 24000 pulses. For example, if the pulse/rotate setting is set to 100 pulses, then 10 rotations of data samples will be acquired when the record length is set to 1 kWord. When the pulse/rotate setting is set to 1 pulse, one data sample will correspond to one rotation (one cycle).

The pulse/rotate setting affects only the X-axis (horizontal) measurement values in cursor measurements and the time axis display on the screen. For example, if the pulse/rotate setting is 100 pulses and the record length is 1 kWord, 1 division will be equal to 1 rotation. In this case, moving the cursor by 1 division during cursor measurements causes the horizontal measured value to increase or decrease by "1."

**RMS Measurement <Section 5.15>**

If the module of the selected channel is a High-Voltage 100 kS/s, 16-Bit Isolation Module (with RMS), the rms value of the input signal can be observed.

**AC-RMS**

This setting is used when you want to observe only the rms values of the AC signal, eliminating the DC components from the input signal.

**Example**

When the rms value of a 2- $V_{peak}$  sinusoid input signal is measured, a DC waveform at approximately 1.4 V is displayed (see right figure).

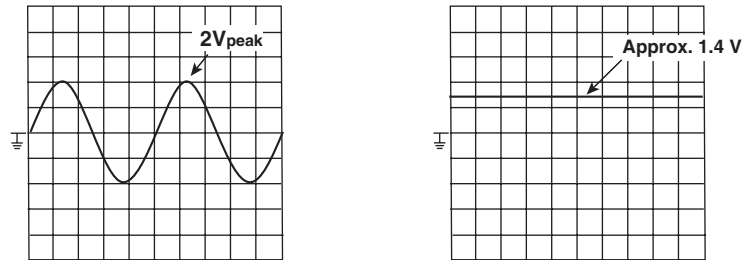

The rms value is derived from the following equation:

$$\sqrt{\frac{1}{T} \int_0^T u(t)^2 dt} \quad \text{Where } u(t) \text{ is the input signal and } T \text{ is one period of the input signal.}$$

If  $u(t) = V_m \sin \omega t$  (where  $V_m$  is the peak value and  $\omega$  is the angular velocity ( $= 2\pi f$ , where  $f$  is the frequency of the sinusoid signal)), the rms value,  $V_{rms}$ , is derived from

$$V_{rms} = \sqrt{\text{The average of } u(t)^2 \text{ over one cycle}} = \sqrt{\frac{1}{2\pi} \int_0^{2\pi} (V_m \sin \omega t)^2 d\omega t} = \frac{V_m}{\sqrt{2}}$$

As in the above example, when  $V_m$  is 2 V, the rms value,  $V_{rms}$ , is approximately 1.4 V.

**DC-RMS**

This setting is used when you want to observe the rms values of both the DC and AC components of the input signal.

**Example**

When the rms value of a 2- $V_{peak}$  sinusoid input signal riding on top of a 1-V DC component is measured, a DC waveform at approximately 1.7 V is displayed (see right figure).

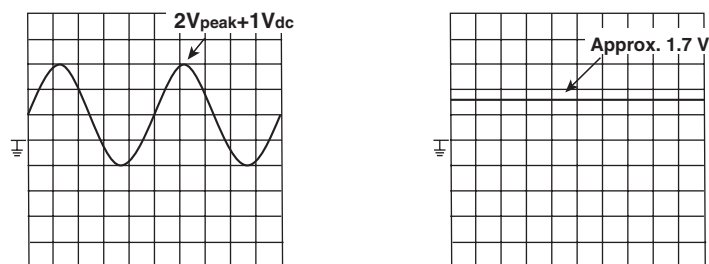

If the DC component is expressed as  $V_{dc}$  and the AC component as  $u(t) = V_m \sin \omega t$ , the rms value,  $V_{rms (+DC)}$ , of the sinusoid input signal riding on top of the DC component is derived from the following equation:

$$V_{rms(+DC)} = \sqrt{\frac{1}{2\pi} \int_0^{2\pi} (V_m \sin \omega t + V_{dc})^2 d\omega t} = \sqrt{\left(\frac{V_m}{\sqrt{2}}\right)^2 + (V_{dc})^2}$$

As in the above example, when  $V_{dc}$  is 1 V and  $V_m$  is 2 V, the rms value,  $V_{rms (+DC)}$ , is approximately 1.7 V.

## Temperature Measurement <Section 5.16>

### **Thermocouple Types**

The following types of thermocouples can be used.

K, E, J, T, L, U, R, S, B, N, W, and Au7Fe

### **Selectable Temperature Units**

You can select °C, K, or °F.

### **Reference Junction Compensation (RJC)**

- The voltage generated by a thermocouple depends on the temperature of the spot of measurement and the reference junction temperature. In this case, the function used to compensate the temperature on the measurement instrument side to the cold junction is referred to as reference junction compensation.
- You can turn ON/OFF the internal RJC circuit on the DL750/DL750P.
  - ON: Use this setting to enable the reference junction compensation by the internal RJC circuit.
  - OFF: Use this setting when checking the temperature measurement value, or when using an external reference junction (0°C).

### **Burnout**

Specify the behavior when the thermocouple input detects a burnout.

ON: Fix the measured value to the upper limit of the measurement range of each thermocouple when a burnout is detected.

OFF: Burnouts are not detected.

### Strain Measurement <Section 5.17>

Strain can be measured by connecting a strain gauge bridge (bridge head) or a strain gauge transducer to the strain module.

#### Relationship between the Strain ( $\mu\text{STR}$ ) and the Transducer Output (mV/V)

The DL750/DL750P allows the unit to be changed between “the strain unit ( $\mu\text{STR}$ :  $\times 10^{-6}$  strain)” and “the output unit of the strain gauge transducer (mV/V)<sup>1</sup>.” The default setting is “strain ( $\mu\text{STR}$ ).” The following relationship exists between  $\mu\text{STR}$  and mV/V.

$$(\text{mV/V}) = 0.5 \times (\mu\text{STR}) / 1000$$

#### Example

$$500 (\mu\text{STR}) \rightarrow 0.5 \times 500 (\mu\text{STR}) / 1000 = 0.25 (\text{mV/V})$$

#### Gauge Factor (K) when mV/V Is Selected

$$K = 2$$

You can set the gauge factor to an arbitrary value on the DL750/DL750P. However, if there are no specifications on the strain gauge transducer, set K to 2.

If K is not 2, e is derived within the DL750/DL750P using the following equation.

$$e = (4/K) \times (V/E)$$

e: Measured value of the strain gauge transducer [mV/V]

V: Voltage measured on the bridge [V]

E: Voltage applied to the bridge [V]

K: Gauge factor

When you switch the unit, the unit of all related parameters of the channel is switched accordingly.

- Upper and lower limits
- Trigger level
- Values of automated measurement of waveform parameters and cursor measurements, etc.

In addition, the 701271 Strain Module (STRAIN\_DSUB) supports shunt calibration.<sup>2</sup>

1. Unit corresponding to the output of the strain gauge transducer. A value expressing the transducer output per volt applied to the bridge in mV. You can set the bridge voltage (excitation: voltage applied to the bridge) from 2 V, 5 V, and 10 V. However, since the mV/V value is a converted value, the measured value is basically constant.
2. Shunt calibration refers to the act of correcting the gain of the strain measurement by connecting a known resistance (shunt calibration resistance) to the strain gauge in parallel.

For a description of the basic defining equation of strain, see appendix 10. For details on shunt calibration, see appendix 11.

### Acceleration Measurement <Section 5.18>

The Acceleration Module (with AAF) (701275 (ACCL/VOLT)) measures acceleration using the output signal from the acceleration sensor. Direction connection is possible to a built-in amplifier type acceleration sensor. (Direct connection is not possible to a charge output type acceleration sensor that does not have a built-in amplifier. For details on the connection of the acceleration sensor, see section 3.12.)

---

**Note**

The 701275 (ACCL/VOLT) can also measure voltage.

---

#### **Current Supply to Acceleration Sensors**

The 701275 (ACCL/VOLT) can supply 4 mA of current to the acceleration sensor when measuring acceleration.

---

**Note**

If you supply current to the acceleration sensor before it is connected to the item under measurement, the internal circuit of the acceleration sensor may be damaged. Be sure to supply current after connecting the acceleration sensor.

---

#### **Filter**

If you set the bandwidth limit to Auto, the anti-aliasing filter (AAF) and low-pass filter are enabled depending on the sample rate to eliminate high-frequency noise from the input signal. Using the anti-aliasing filter when measuring voltage allows elimination of aliasing noise resulting from FFT computation, digital filter computation of DSP channels, etc. For details on the bandwidth limit, see section 5.7.

---

**Note**

The filter is effective not only during acceleration measurement but also during voltage measurement.

---

**Frequency (Number of Rotations, Period, Duty Cycle, Power Supply Frequency, Pulse Width, Pulse Integration, and Velocity) Measurement <Section 5.19>**

The Frequency Module (701280 (FREQ)) measures frequency, number of rotations, period, duty cycle, power supply frequency, pulse width, pulse integration, and velocity.

• **Frequency**

Frequency (Hz) = 1/Tw (s)  
 Measurable range: 0.01 Hz to 200 kHz

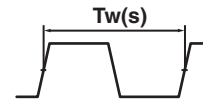

• **Period**

Period (s) = Tw (s)  
 Measurable range: 5 μs to 50 s

• **RPMS/RPSs**

RPMS = Frequency (Hz)/the number of pulses per rotation (Nr) × 60  
 Measurable range: 0.01 rpm to 100000 rpm  
 RPSs = Frequency (Hz)/the number of pulses per rotation (Nr)  
 Measurable range: 0.001 rps to 2000 rps

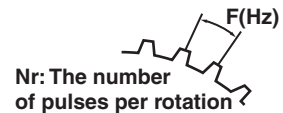

• **Duty Cycle**

Duty cycle (%) = Thigh (s)/Tw (s)  
 Or, duty cycle (%) = Tlow (s)/Tw (s)  
 Measurable range: 0% to 100%

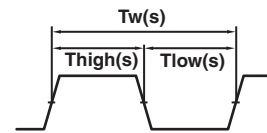

• **Pulse Width**

Pulse width (s) = Thigh (s)  
 or pulse width (s) = Tlow (s)  
 Measurable range: 2 μs to 50 s

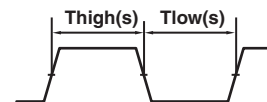

• **Power Supply Frequency**

Power supply frequency (Hz) = 1/Tw (s)  
 Resolution: 0.0 1Hz  
 Measurable range: (50 Hz, 60 Hz, or 400 Hz) ± 20 Hz

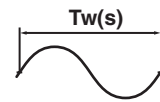

• **Pulse Integration (Distance/Flow Rate)**

Pulse integrated value = N (count) × physical amount per pulse (l)  
 Set the physical amount per pulse (l) to distance or flow rate.  
 A suitable user-defined unit can be assigned to the specified physical amount.  
 Measurable range: Up to 2×10<sup>9</sup> counts

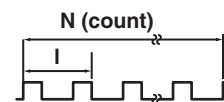

• **Velocity**

Velocity (km/h) = Distance per pulse l (km)/Tw (s) × 3600  
 Velocity (m/s) = Distance per pulse l (m)/Tw (s)  
 The distance and unit can be user defined (angular velocity, etc.).  
 Measurable range: F (=1/Tw) = 0.01 Hz to 200 kHz

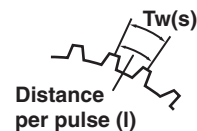

**Deceleration Prediction and Stop Prediction**

The 701280 (FREQ) automatically performs internal computation and displays waveforms by predicting the deceleration curve and stop point even when the input pulse is suddenly cut off. This function allows the measurement of waveforms of deceleration behavior that is close to the actual physical phenomenon in applications in which the deceleration behavior of an object that have inertia is measured such as in the brake test of automobiles.

**Deceleration Prediction**

The deceleration curve is computed according to the following equation using the elapsed time after the pulse input stops ( $\Delta t$ ).

Frequency ( $f$ ) =  $1/\text{elapsed time } (\Delta t)$

The deceleration prediction starts after a pulse period ( $T$ ) of the pulse one period before the pulse input stopped elapses after the pulse input stopped.

**Stop Prediction**

The function determines the stop point at a certain time after the pulse input stops, and the frequency is set to 0. The time from the point when the pulse input stops to the point when the function determines that the object has stopped can be set to  $\times 1.5$ ,  $\times 2$ ,  $\times 3$ , ...,  $\times 9$ , and  $\times 10$  (10 settings) of the pulse period ( $T$ ) of the pulse one period before the pulse input stopped.

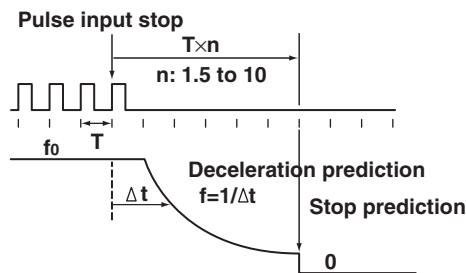

**Filter**

**Smoothing Filter (Moving Average)**

The frequency module can display waveforms by taking the moving average of the data in realtime. The order of moving average can be set in terms of time in the range of 0.1 ms to 1 s (up to 25000 order). The order of moving average is equal to the specified time divided by 40  $\mu$ s.

Below are the characteristics of the smoothing filter.

- Converts a waveform that changes in steps to a smooth waveform
- Improves the resolution by reducing the measurement jitter. The resolution improves when measuring especially high frequencies or when expanding the display using the offset function. Consequently, highly accurate measurements can be made.
- Can be used on all measurement parameters of the frequency module.

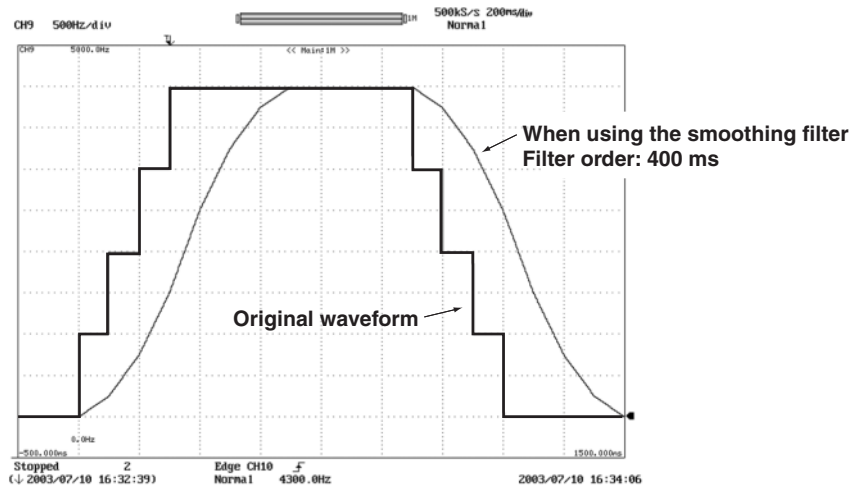

## 2.2 Setting the Horizontal and Vertical Axes

- When using the offset function (see this page) and making measurements by expanding near 100 kHz

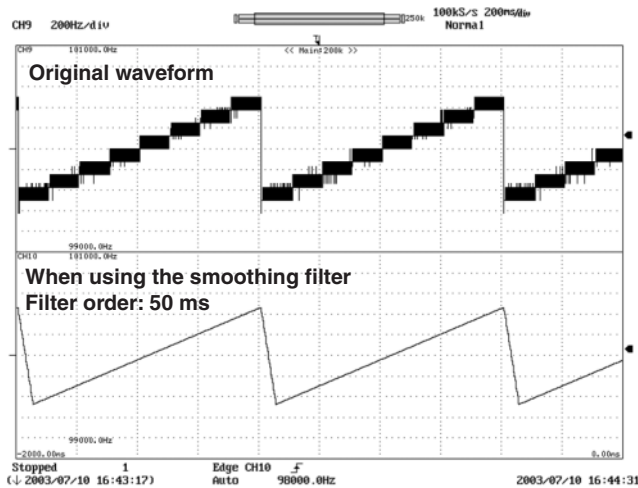

- Value/div: 200 Hz/div
- Upper display limit: 101 kHz
- Lower display limit: 99 kHz

The accuracy improves when the smoothing filter is used.

### Pulse Average

Measures the input pulse by dividing the pulse by the specified number of pulses (1 to 4096 pulses). Below are the characteristics of the pulse average.

- If pulse dropouts are present or pulse interval is fluctuating within one period, measurements can be made by eliminating the effects from the dropout or fluctuation (fluctuating component of the waveform used to measure the frequency or period).
- The measured result is displayed as a value per input pulse even when pulse average is used. Therefore, there is no need to perform scaling again.
- Can be used when measuring frequency, number of rotations, power supply frequency, pulse integration, and velocity.

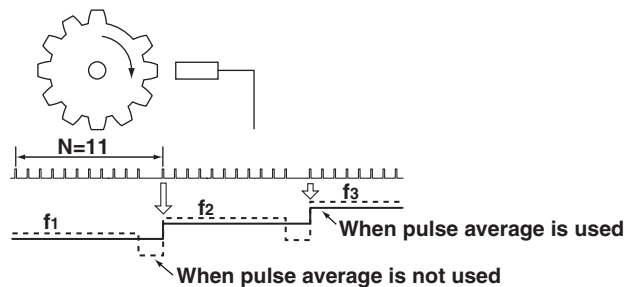

### Offset Function

The 701280 (FREQ) allows you to set the center of observation (offset value) and expand the area around the offset value for close observation. You can measure the fluctuation around a certain frequency. You can set the offset value up to 1000 times the Value/div value (up to 200 kHz).



**Logic Waveforms <Section 5.20>**

Logic waveforms can be measured by connecting logic probes to the logic signal input connectors (two connectors marked LOGIC A and LOGIC B) on the left side panel. A-1 to A-8 (8 bits) and B-1 to B-8 (8 bits) can be input to the LOGIC A and LOGIC B ports, respectively.

**Event Waveforms <Section 5.21>**

The times when triggers are activated with the dual capture function and the period during which voice memos are recorded can be displayed as events.

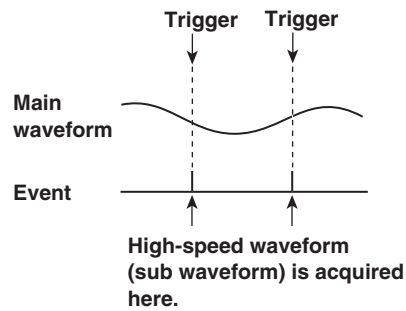
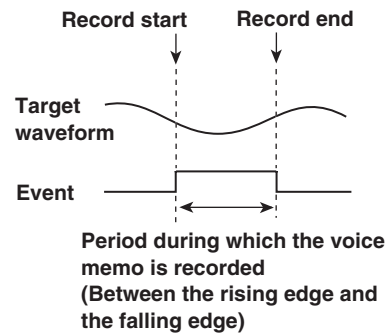
• **Events during dual capture**• **Events on voice memos**

## 2.3 Setting the Trigger

### Trigger Type <Chapter 6>

The trigger on the DL750/DL750P can be classified into two main types: simple trigger and enhanced trigger.

#### Simple Trigger

This function activates a trigger on a single trigger source.

- **Input Signal Trigger**

A trigger is activated when the trigger source (input signal of CH1 to CH16, DSP1 to DSP6 (optional), LOGIC A, or LOGIC B) reaches or exceeds the preset trigger level (rising) or falls to or below the trigger level (falling) or both.<sup>1</sup>

1. "A trigger is activated" refers to the condition in which trigger conditions are satisfied and a waveform is displayed.

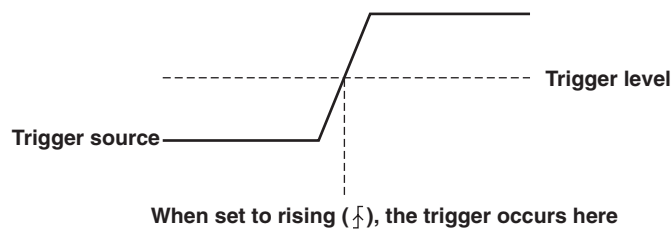

- **External Trigger**

A trigger is activated using the external signal applied to the EXT TRIG IN terminal on the side panel of the DL750/DL750P.

- **Line Trigger**

A trigger is activated using the rising edge of the power signal that is being supplied to the DL750/DL750P. Waveforms can be observed by synchronizing to the commercial power supply frequency (50 Hz or 60 Hz).

- **Timer Trigger**

A trigger is activated at specified time intervals (1 min to 24 hours) from a specified time.

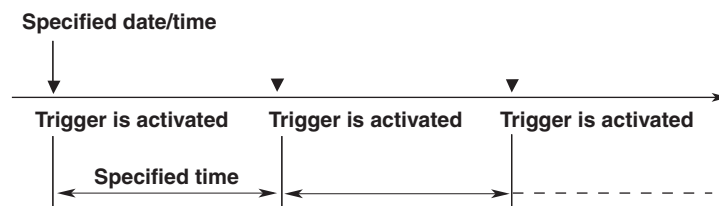

**Enhanced Trigger**

**A -> B(N) Trigger**

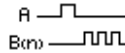

A trigger is activated the  $n^{th}$  time condition B becomes true after condition A has become true.

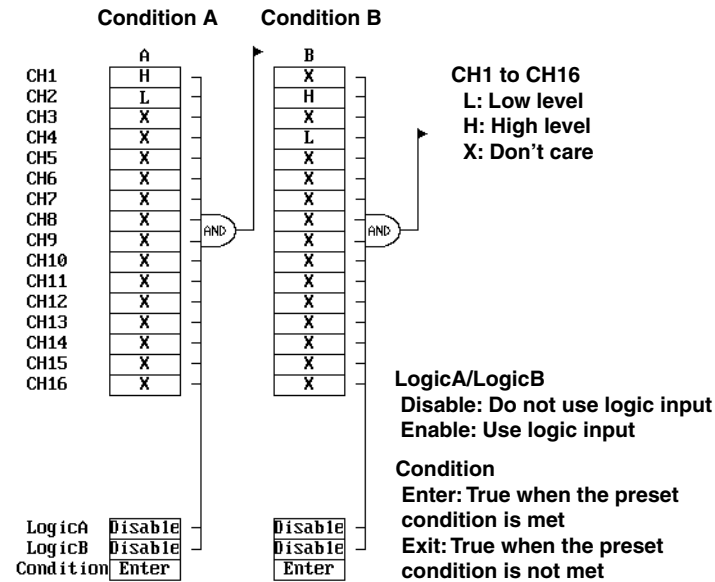
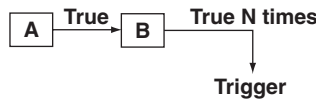

**A Delay B Trigger**

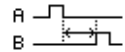

A trigger is activated the 1<sup>st</sup> time condition B becomes true after condition A has become true and a preset time has elapsed.

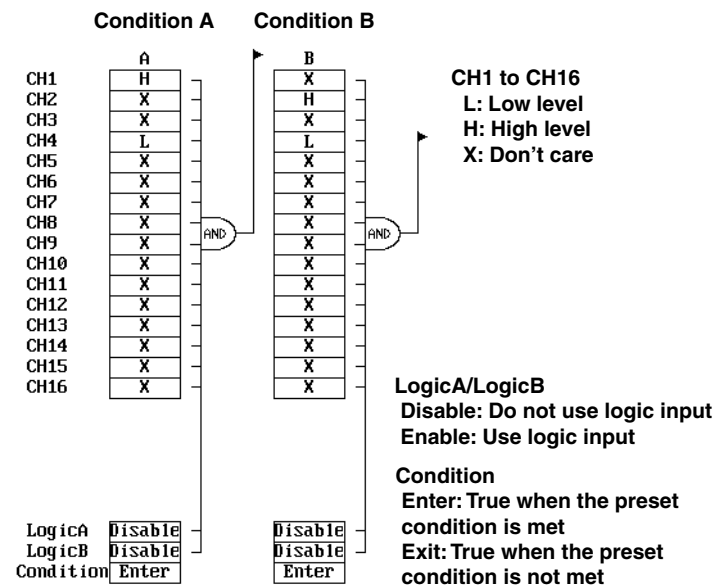
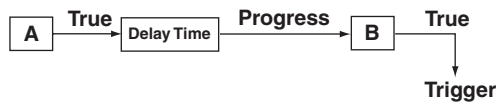

## 2.3 Setting the Trigger

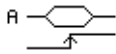

### Edge on A Trigger

A trigger is activated when an edge trigger is detected on any of the channels set to edge trigger while condition A is true.

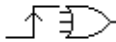
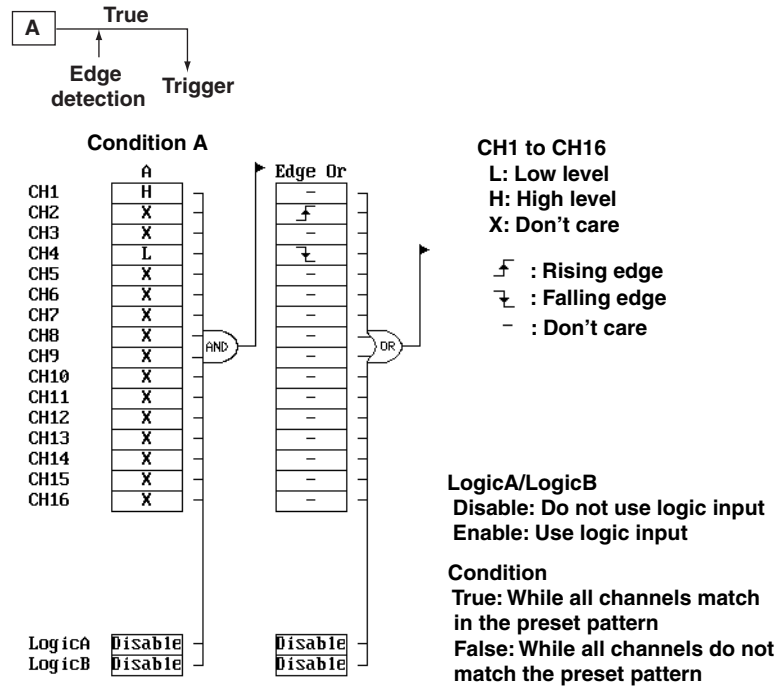

### OR Trigger

A trigger is activated when any of the channels set to edge trigger meets the condition. For example, a trigger can be activated on the rising edge of CH1 or CH2.

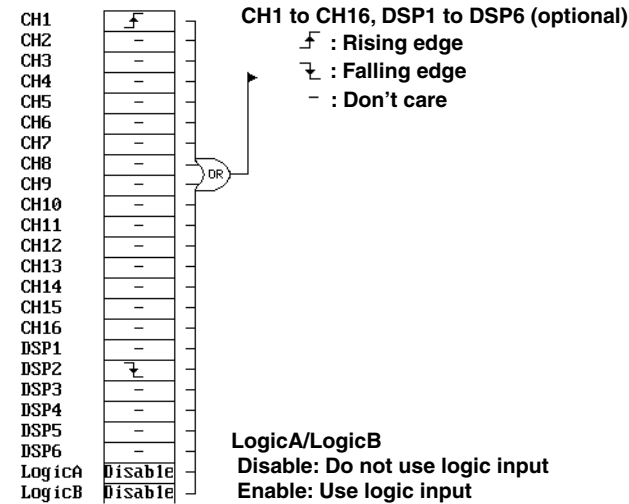

**B > Time Trigger, B < Time Trigger, and B TimeOut Trigger**

A trigger is activated on the falling or rising edge of the pulse when the pulse width (width over which condition B is met) exceeds (or drops below) the preset time. In the case of a Time out trigger, a trigger is activated when the preset time elapses.

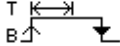
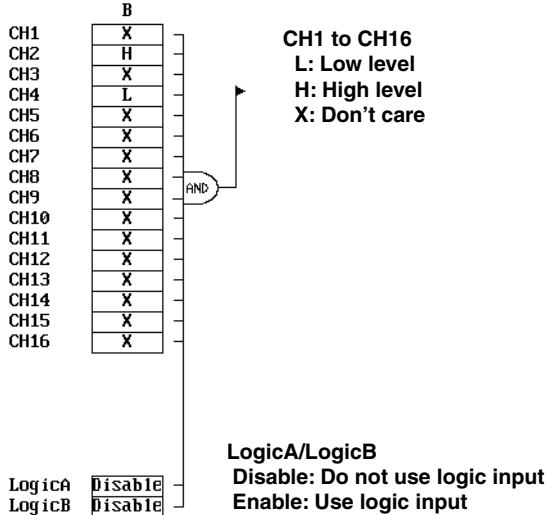

• **B > Time Trigger**

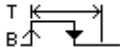
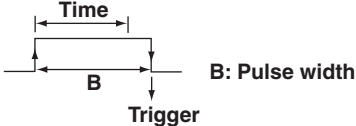

• **B < Time Trigger**

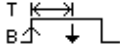
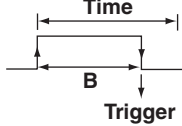

• **B TimeOut Trigger**

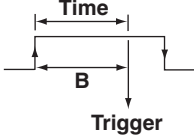

## 2.3 Setting the Trigger

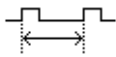

### Period Trigger

A trigger is activated by measuring the pulse period (period from the time condition T is met to the next time when condition T is met).

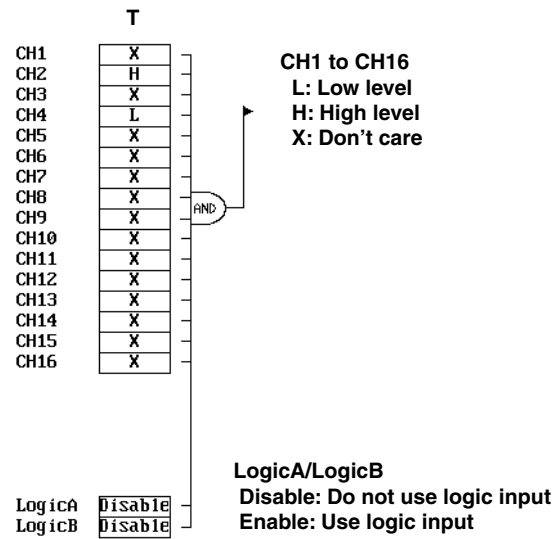

- **T > Time**

A trigger is activated when condition B is met the second time (T), if the time when condition B is met the second time is longer than a specified time (Time).

When condition B: CH1=H and Time=10  $\mu$ s

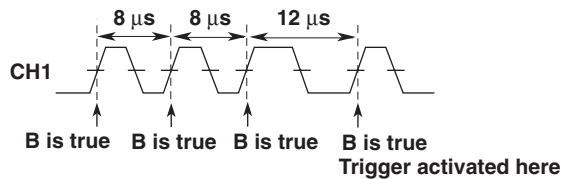

- **T < Time**

A trigger is activated when condition B is met the second time (T), if the time when condition B is met the second time is shorter than a specified time (Time).

When condition B: CH1=H and Time=10  $\mu$ s

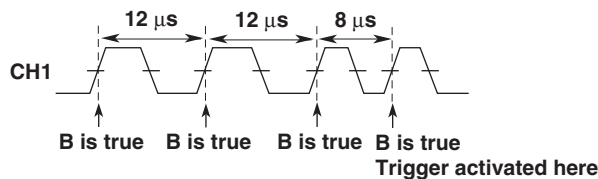

- **T1 < T < T2**

A trigger is activated when condition B is met the second time (T), if the time when condition B is met the second time is within a specified time range (T1 and T2).

When condition B: CH1=H, Time1=10  $\mu$ s, and Time2=14  $\mu$ s

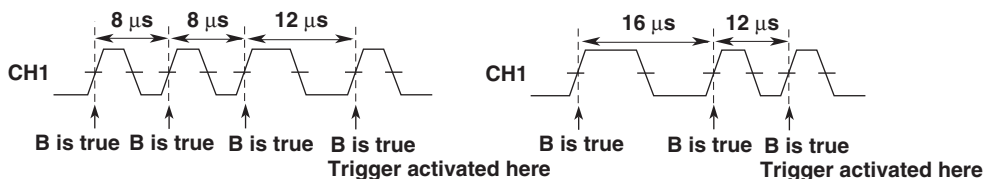

- $T < T1, T2 < T$

A trigger is activated when condition B is met the second time (T), if the time when condition B is met the second time is outside a specified time range (T1 and T2).

When condition B: CH1=H, Time1=6  $\mu$ s, and Time2=10  $\mu$ s

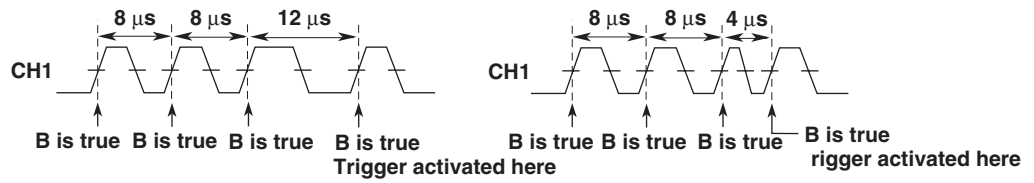

**Window Trigger**

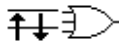

A certain voltage range (window) is set and a trigger is activated when the trigger source level enters this voltage range (IN) or exits from this voltage range (OUT)

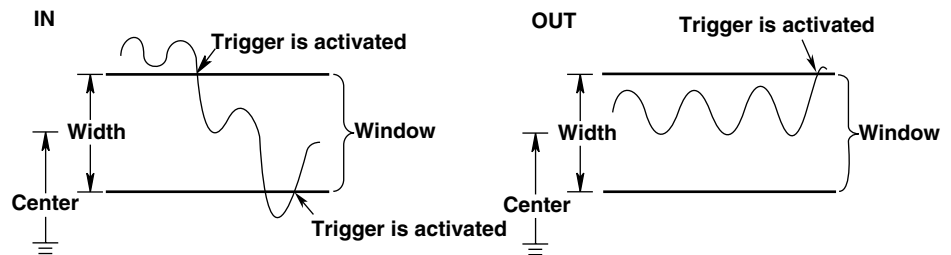

	Window
CH1	IN
CH2	-
CH3	OUT
CH4	-
CH5	-
CH6	-
CH7	-
CH8	-
CH9	-
CH10	-
CH11	-
CH12	-
CH13	-
CH14	-
CH15	-
CH16	-
DSP1	-
DSP2	IN
DSP3	-
DSP4	-
DSP5	-
DSP6	-
LogicA	Disable
LogicB	Disable

CH1 to CH16, DSP1 to DSP6 (optional)

IN: Enters the window  
 OUT: Exits from the window  
 -: Don't care

**LogicA/LogicB**

Disable: Do not use logic input  
 Enable: Use logic input

Edge trigger is used for the logic input.

f : Don't care  
 ↓ : Falling edge  
 ↑ : Rising edge

## 2.3 Setting the Trigger

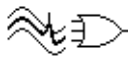

### • Wave Window Trigger

This trigger is used to monitor the power supply waveform. It detects abnormalities in the power supply (disruption, sag, surge, frequency fluctuation, voltage drop, etc.). A reference waveform (realtime template) is created by setting a tolerance (window width) to a waveform derived by averaging 1 to 4 cycles of waveforms before a cycle the current waveform. The current waveform is compared against the realtime template. If the current waveform falls outside the realtime template, a trigger is activated.

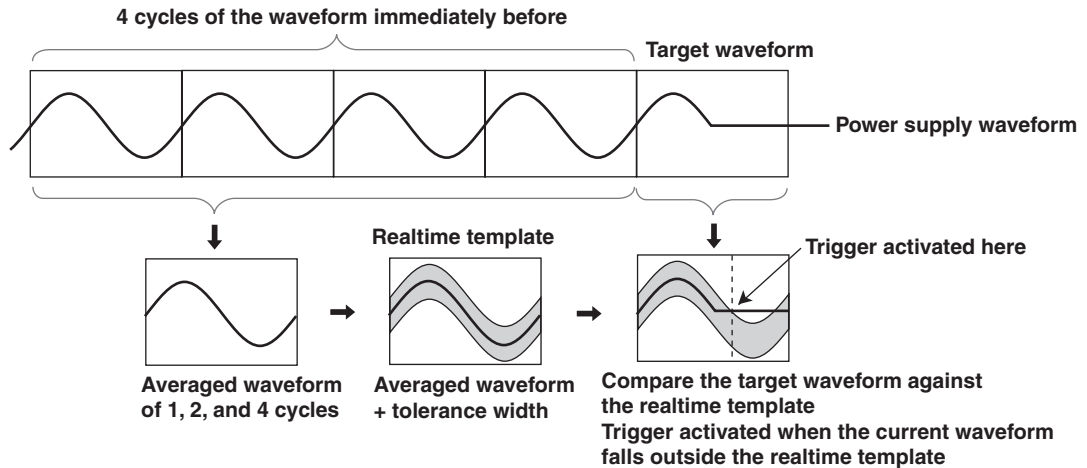

### Wave window trigger example

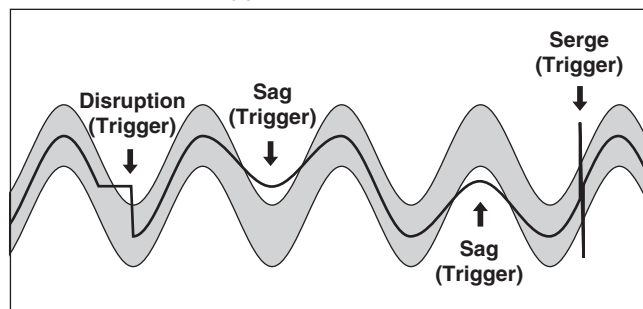

CH1	OFF
CH2	OFF
CH3	OFF
CH4	OFF
CH5	OFF
CH6	OFF
CH7	OFF
CH8	OFF
CH9	OFF
CH10	OFF
CH11	OFF
CH12	OFF
CH13	OFF
CH14	OFF
CH15	OFF
CH16	OFF

#### CH1 to CH16

ON: Use as a trigger source  
OFF: Not use as a trigger source

Cycle Frequency	50Hz
Reference Cycle	1
Sync.Ch	Auto
Level	
Hys	≠

Cycle Frequency: Power supply frequency of the measured item  
Reference Cycle

Sync.Ch : Synchronization channel<sup>1</sup> for starting triggers

Level: Level of the synchronization channel

Hys: Hysteresis of the synchronization channel

1. Synchronization channel: Because waveform determination is performed per cycle in wave window trigger, synchronization signal must be retrieved from the reference channel, and the start and end points of comparison must be detected. This reference channel is called a synchronization channel. Sync.Ch is used to specify the synchronization channel, and Level is used to specify the start level of the synchronization channel. Normally, Sync.Ch is set to Auto (the channel with the smallest number among the modules that can perform wave window trigger). However, if the trigger is not activated adequately, specify an appropriate channel.



## Trigger Mode <Section 6.1>

Sets the conditions for updating the displayed waveforms. The following six trigger modes are available.

### Auto Mode

If a trigger occurs within a specified amount of time (approximately 50 ms, referred to as the timeout period), the displayed waveforms are updated. If a trigger is not activated within the timeout period, the displayed waveforms are automatically updated.

### Auto Level Mode

Within the timeout period (approximately 1 s), the waveforms are displayed in the same fashion as in the auto mode. If a trigger is not activated within the timeout period, then the center value of the amplitude of the trigger source is detected, and the trigger level is changed to that value. A trigger is activated using the new value, and the displayed waveforms are updated.

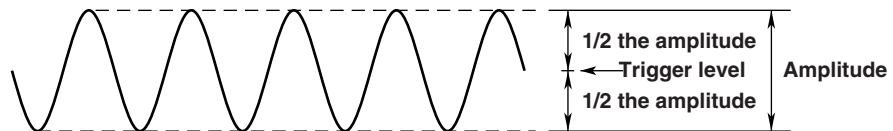

### Normal Mode

The displayed waveforms are updated only when a trigger occurs. The displayed waveforms are not updated if a trigger does not occur.

### Single Mode

When a trigger is activated, displayed waveforms are updated only once, then acquisition stops. This mode is useful when you are observing a single-shot signal.

### Single (N) Mode (Sequential Store Function)

This mode is selected when using the sequential store function (see section 7.5). Waveforms are acquired and stored in different memory areas each time a trigger is activated the specified number of times. Then, acquisition is stopped, and all the acquired waveforms are displayed. Acquired waveforms can be displayed together, or they can be displayed individually. This mode is useful when you wish to detect sudden abnormalities in a waveform.

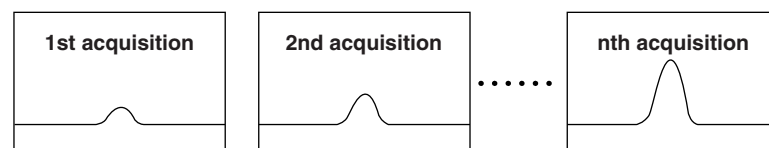

### Log Mode

In this mode, the trigger settings are disabled. The specified record length of data is acquired once when acquisition is started, and the displayed waveforms are updated.

**Trigger Delay <Section 6.3>**

Normally, the waveform around the trigger point is displayed. However, by setting a trigger delay, you can display the waveform that is acquired a specified time after the trigger point. The selectable range of trigger delay is 0 to 10 s.

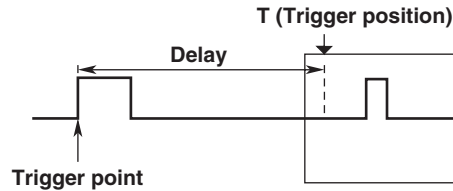

**Trigger Position <Section 6.2>**

The trigger position specifies the position of the waveform captured in the acquisition memory to be displayed on the screen. The point at which the trigger occurred is called the trigger point. If the trigger delay described in the previous section is set to 0 s, the trigger point and the trigger position match. By moving the trigger position, you can observe the pretrigger section of the waveform before the trigger point.

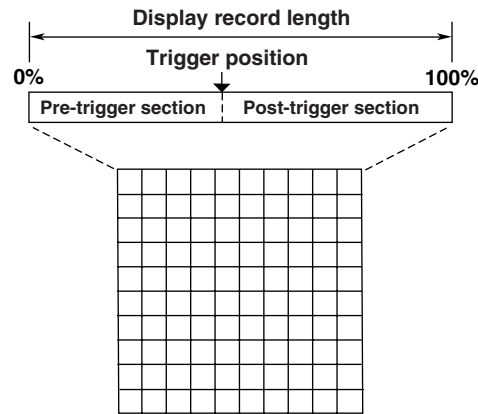

**Trigger Source, Trigger Slope, and Trigger Level <Sections 6.5 to 6.16>**

**Trigger Source**

Trigger source refers to the target channel on which trigger conditions are specified. You can set external trigger signals and commercial power supply as trigger sources.

**Trigger Slope**

Trigger slope defines how the trigger source is to cross a specified level for activating the trigger. Select the trigger slope from  $\uparrow$  (rising),  $\downarrow$  (falling), and  $\updownarrow$  (both rising and falling).

**Trigger Level**

Trigger level refers to the voltage level that is used to determine the trigger slope (rising/falling edge of the signal) or other items.

### Trigger Hysteresis <Sections 6.5 to 6.16>

If noise is present in the trigger source and there is insufficient trigger level width, the trigger point fluctuates each time a trigger is activated. This causes the displayed waveforms to be unstable. To solve this problem, a specified margin (hysteresis) is added to the trigger level. You can select the trigger hysteresis from the following:  $\overline{\Delta}$ ,  $\overline{\nabla}$ , and  $\overline{\neq}$ . The hysteresis width varies depending on the input module.

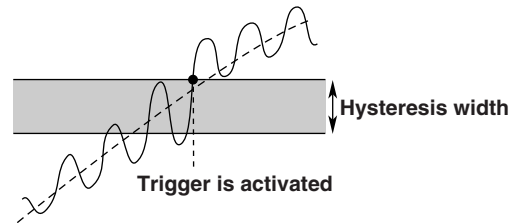

### Trigger Hold-off <Section 6.4>

The trigger hold-off function temporarily stops the detection of the next trigger once a trigger has been activated. This function is useful when observing a pulse train signal, such as a PCM code and you wish to display the waveform in sync with repetitive cycles; or when using the history memory function described later and you want to change the waveform acquisition period.

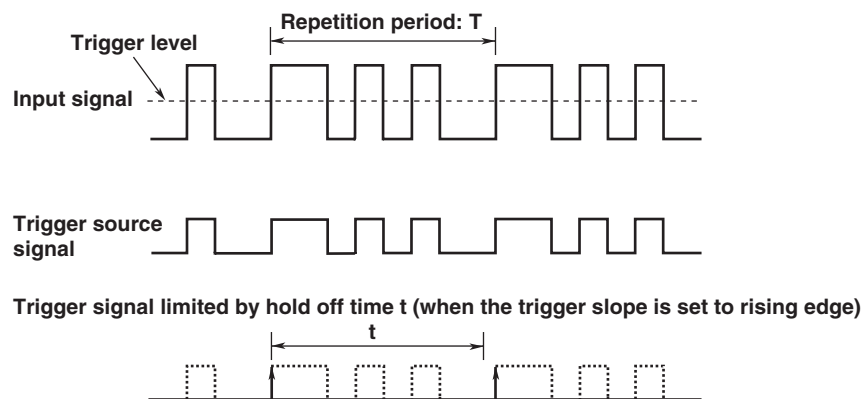

### Action-on-Trigger <Section 6.18>

A specified action can be carried out each time a trigger occurs or when the waveform is displayed after acquiring the specified record length of data or when measurement is stopped after the measurement is started.

- **Print the Screen Image Data (PRINT)**  
Prints the screen image data to a specified printer.
- **Save the Screen Image Data (Image)**  
Saves the screen image data to the save destination specified in the IMAGE SAVE menu.
- **Save Waveform Data (Save to File)**  
Saves the waveform data in binary, ASCII, or floating format to the save destination specified in the FILE menu.
- **Beep Sound (Buzzer)**  
Sounds a buzzer.
- **Send Mail**  
Sends an e-mail message to a specified address. (when the Ethernet interface option is installed)

## 2.3 Setting the Trigger

---

### Manual Trigger <Section 6.19>

You can activate a trigger by pressing the MANUAL TRIG key on the front panel

## 2.4 Setting Waveform Acquisition Conditions and Display Conditions

### Record Length <Section 7.2>

The term “record length” normally refers to the number of data points acquired per channel in the acquisition memory. “Displayed record length” refers to the number of these data points that are actually displayed on the screen. The sample rate and record length vary depending on the time axis setting. The DL750/DL750P allows you to select the record length from the following: 1 kW, 2.5 kW, 5 kW, 10 kW, 25 kW, 50 kW, 100 kW, 250 kW, 500 kW, 1 MW, 2.5 MW, 5 MW, 10 MW, 25 MW, 50 MW, 100 MW, 250 MW, 500 MW, and 1 GW. (The maximum record length that can be selected varies depending on the memory option.)

When the M3 option is installed, the entire data length of up to 1 GW (1 CH) can be displayed instantaneously.

The length of time that can be recorded on 1 GW of memory is as follows:

Sample Rate	In Seconds	In Minutes	In Hours	In Days
10 MS/s	100	1.67	0.028	0.001
1 MS/s	600	10	0.167	0.007
100 kS/s	9000	150	2.5	0.10
10 kS/s	72000	1200	20	0.83
1 kS/s	864000	14400	240.0	10
200 S/s	2592000	43200	720.0	30

In most cases the displayed record length is identical to the (acquisition) record length. For certain time-axis settings, however, the lengths become different. For details, see appendix 1, “Relationship between the Time Axis Setting, Sample Rate and Record Length.”

### Acquisition Mode <Sections 7.3 and 7.4>

When storing sampled data in the acquisition memory, it is possible to perform processing on data and display waveforms based on the processed data. The following four types of data processing are available.

#### Normal Mode

In this mode, sampled data is stored in the acquisition memory without processing.

#### Averaging Mode

Averaging is a process in which waveforms are acquired repeatedly to obtain the average of waveform data at the same time point (the same time in relation to the trigger point).

The DL750/DL750P takes the linear or exponential average of the waveform data and writes the results into the acquisition memory. The averaged data is then used to generate the display. You can set the attenuation constant to a value between 2 and 256 (in 2<sup>n</sup> steps), and the averaging count to a value between 2 and 65536.

**Exponential averaging (when set to infinite)**      **Simple average (when set to 2 to 65536)**

$$A_n = \frac{1}{N} \{(N-1)A_{n-1} + X_n\}$$

**A<sub>n</sub>**: nth averaged value

**X<sub>n</sub>**: nth measured value

**N**: Attenuation constant (2 to 256, 2<sup>n</sup> steps)

$$A_N = \frac{\sum_{n=1}^N X_n}{N}$$

**X<sub>n</sub>**: nth measured value

**N**: Average count

(acquisition count, 2<sup>n</sup> steps)

The averaging process is useful in eliminating random noise.

## 2.4 Setting Waveform Acquisition Conditions and Display Conditions

### Envelope Mode

In normal mode and averaging mode, the sample rate (the number of times data is acquired per second in the acquisition memory) drops if T/div is increased. (See Appendix 1 "Relationship between the Time Axis Setting, Sample Rate and Record Length.")

However, in the envelope mode, the maximum and minimum values are determined at every time interval from the data sampled at the maximum sample rate of each input module. The time interval used to determine the value is equal to twice the sample rate of the normal mode. The maximum and minimum values are paired and stored in the acquisition memory.

Envelope mode is useful when you want to avoid aliasing, since the sample rate is kept high irrespective of the time axis setting. It is also useful when you want to detect glitches (pulse signals which rise very fast) or display an envelope of a modulating signal.

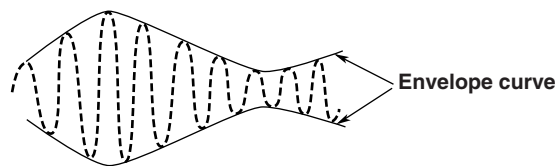

### Box Average Mode

The rolling average of the data sampled at the maximum sample rate of the 701250 (HS10M12) and 701255 (NONISO\_10M12) is determined. The resultant data is stored in the acquisition memory and used to generate the display. Box averaging is useful for eliminating small amount of noise on the input signal. It can also remove noise from a single-shot signal.

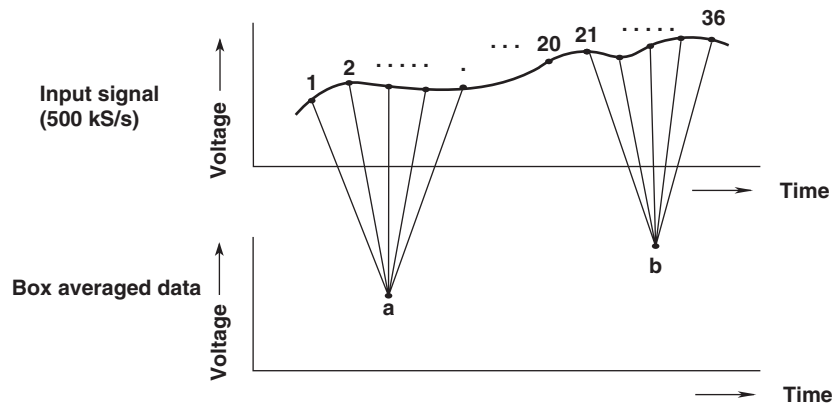

### Sequential Store Function <Section 7.5>

In the case of the history memory function, the waveform data of each block is updated in order until the measurement is stopped. However, in the sequential store function, you specify the waveform acquisition count (number of blocks), and the measurement stops when the specified count is reached. The updating of the waveform display is carried out after acquiring the entire waveform data. To acquire waveforms using this function, set the trigger mode to Single(N). The maximum Single(N) count is equal to N that is explained in the history memory function. The stored waveform data can be recalled using the history memory function.

The figure below shows an example when data is sequentially stored 100 times.

Display example when the acquisition count is 100

• Displaying all waveforms (when all display is executed)

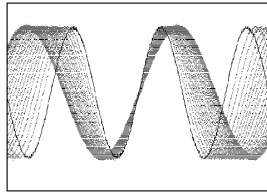

• Display the newest waveform (When Selected Record No. = 0)

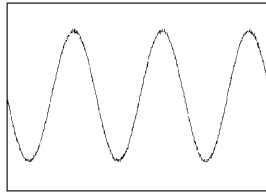

• Display the oldest waveform (When Selected Record No. = -99)

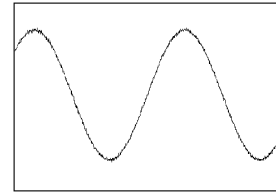

### History Memory Function <Section 11.1>

If the record length is set short on the DL750/DL750P, the memory is divided into blocks, and waveform data is saved to the individual blocks each time a trigger occurs. If N represents the maximum number of blocks determined by the record length, the oldest waveform data block is cleared when the number of activated triggers exceeds N. If you stop the measurement, you can recall the waveform data stored in each block and display the data on the screen. The record length of a single waveform (one channel and one acquisition) is the same as the maximum display length. Once the specified number of waveforms have been stored, you can display any of the waveforms individually or all of them together. This function is useful when capturing the changes in the waveform over time.

The following figure indicates an example when N = 100.

Holds waveform data of the last 100 triggers

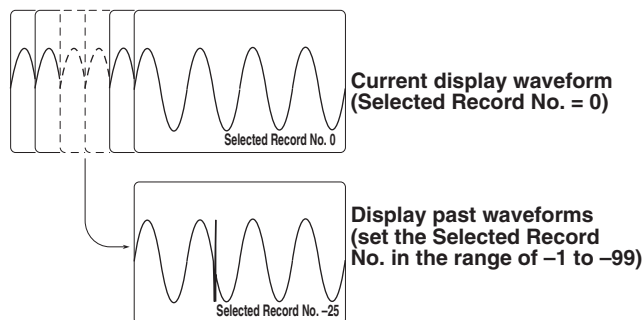

You can also search a particular waveform from the past waveforms that are held (history search function).

For details, see "History Search Function" in section 2.7.

**Dual Capture Function <Section 7.6>**

This function enables waveform acquisition in low-speed roll mode (main waveform) along with high-speed waveforms (sub waveform) using a different sampling interval. It is useful when capturing at high speeds abnormal phenomenon that occurs suddenly during long-term observation (low-speed sampling). When the waveform data is saved, the sub waveform is saved along with the main waveform. Likewise, when the main waveform is loaded, the sub waveform is also loaded. This function is valid when the acquisition mode is set to normal, envelope, or box average. In addition, the acquired waveform data can be recalled from a memory different from the history memory.

**Main waveform: Roll mode display**

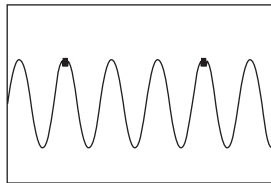

100 MW maximum

**Sub waveform: Trigger display**

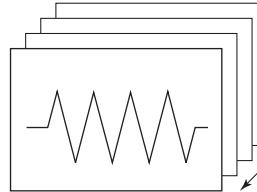

10 kW × 100 screens (standard model)

100 screens maximum (standard model)  
250 screens maximum (/M1 model)  
500 screens maximum (/M2 and /M3 models)

**Event waveforms**

Displays the time when the sub waveform was acquired as an event waveform  
Sub waveform acquired here

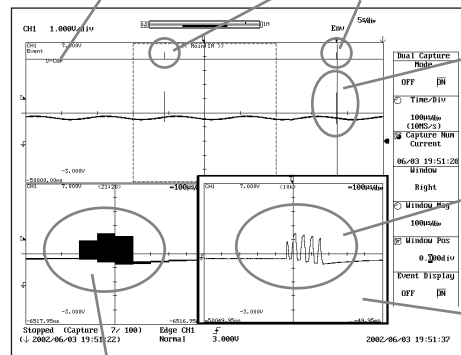

**Main waveform**

Observe this phenomenon using the zoom function (horizontal zoom) and Dual Capture function (T/div: both 100 μs/div)

When displayed using the Dual Capture function  
Able to observe the occurrence of five burst waveforms

Sub (high-speed) waveform display frame

**When displayed using the zoom function  
Cannot tell how many burst waveforms occurred**

The dual capture function can be used in the following two trigger modes.

• **Auto Mode**

For the main waveform, measurement is performed from the time sampling is started until there is a request to end the sampling. For the sub waveform, up to 100\* sets can be stored. When this number is exceeded, the oldest sub waveforms are deleted as new ones are stored, so that only the 100\* newest sub waveforms are stored at any given time.

\*: 250 sub waveforms on the /M1 model. 500 sub waveforms on the /M2 and /M3 models.

• **Log Mode**

For the main waveform, the waveform is acquired from the time sampling is started up to the specified record length. (The acquisition stops also when 10 divisions of waveform are displayed.) For the sub waveform, up to 100\* sets can be stored. In addition, you can view the past sub waveform data while acquiring the waveform.

\*: 250 sub waveforms on the /M1 model. 500 sub waveforms on the /M2 and /M3 models.

**Note**

If waveforms are acquired exceeding the record length specified on the main side in Auto mode, there is a possibility that the waveform acquired on the sub side will not exist on the main side.



### Realtime Recording to the Internal Hard Disk (Option) <Section 7.7>

The data can be recorded in realtime to the internal hard disk (option). The stored data can be recalled. The realtime recording area is allocated on the internal hard disk in advance (the default value is 50% of the entire capacity of the internal hard disk). You can set the realtime recording area in the range of 30% to 70% of the entire capacity of the internal hard disk when you format the internal hard disk (see section 13.5).

The time axis settings, the maximum record length, and the maximum sampling rate that allow realtime recording vary depending on the number of channels to be recorded in realtime as follows.

Channels Used	Time Axis Range	Maximum Record Length	Maximum Sample Rate
18 CH or more	20 s/div to 3 day/div	25 MW	5 kS/s
12 to 17CH	20 s/div to 3 day/div	50 MW	5 kS/s
6 to 11CH	6 s/div to 3 day/div	50 MW	10 kS/s
4 to 5CH	3 s/div to 3 day/div	100 MW	20 kS/s
3CH	2 s/div to 3 day/div	250 MW	50 kS/s
2CH	1 s/div to 3 day/div	500 MW	100 kS/s
1CH	1 s/div to 3 day/div	1 GW	100 kS/s

The following two modes of realtime recording operation are available.

**Single:** Starts realtime recording with the start of waveform acquisition and stops realtime recording when the specified record length is reached.

**Continue:** Starts realtime recording with the start of waveform acquisition and stops realtime recording when the specified record length is reached. This sequence is repeated the specified number of times (count).

If you select Single, the following two trigger modes are available. If you select Continue, only Log is valid.

**Auto:** Acquisition is started by pressing START. If the specified record length is exceeded, old data is overwritten. Acquisition continues until you press STOP.

**Log:** Acquisition is started by pressing START. When the specified record length is reached, acquisition stops.

#### How the Internal Hard Disk (Optional) Is Used

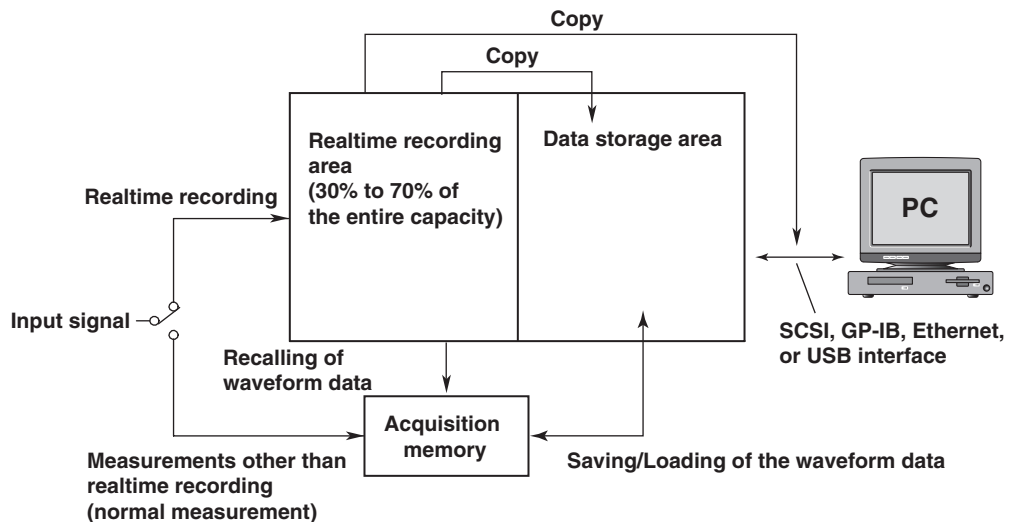

### Action-on-Stop <Section 6.18>

A specified action can be carried out when the waveform is displayed after acquiring the specified record length of data or when measurement is stopped after the measurement is started.

- **Print the Screen Image Data (PRINT)**  
Prints the screen image data to a specified printer.
- **Save the Screen Image Data (Image)**  
Saves the screen image data to the save destination specified in the IMAGE SAVE menu.
- **Save Waveform Data (Save to File)**  
Saves the waveform data in binary, ASCII, or floating format to the save destination specified in the FILE menu.
- **Beep Sound (Buzzer)**  
Sounds a buzzer.
- **Send Mail**  
Sends an e-mail message to a specified address (when the Ethernet interface option is installed).

### Voice Memo Function <Sections 3.14 and 7.9>

When in roll mode display

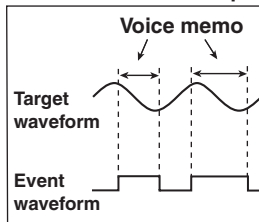

Voice memo is also saved as waveform data when the waveform data is saved.

Voice memos can be recorded while waveforms are being acquired (when in roll mode display). The recording and playing of voice memos are done by connecting an optional earphone microphone with a PUSH switch (sold separately). By connecting a speaker, the voice memo can also be played through a speaker. The recorded voice memo can be saved along with the waveform data. The voice memo can be played by loading the saved waveform data.

The voice memo function can perform the following operations.

- Record: Record mode is enabled by turning ON the PUSH switch of the earphone microphone. The maximum record time is 100 s.
- Save/Load: To save the voice memo, save the waveform data that has the voice memo recorded (waveform data in binary format or realtime recorded waveform data). The voice memo is loaded by loading the saved waveform data allowing it to be played.
- Play: When waveform data that has a voice memo recorded is selected, the recorded voice memo is played.

#### Note

- The voice memo remains only on the newest waveform data that has been stored in the acquisition memory. If you restart data acquisition without saving the waveform data, the voice memo that was attached to the previous waveform will be cleared.
- Voice memos are backed up by the backup function of the acquisition memory.

### Backing Up the Acquisition Memory <Section 7.10>

If the ACQ MEMORY BACKUP switch on the right side panel of the DL750/DL750P is turned ON, the history memory data in the acquisition memory, the sub window data of the dual capture function, and the voice memo data are backed up even if the power supply is cut off. The data held in the acquisition memory is backed up immediately before the power is turned OFF. This function protects the data in the acquisition memory from sudden power failures.

Alkaline dry cells or nickel hydride rechargeable batteries (four AAA batteries) are required for the backup. The backup time varies depending on the operating environment. For reference values of the backup time, see section 19.5, "Function."

**Display Format and Waveform Mapping <Sections 8.1 to 8.4, 8.8 to 8.13>****Display Format**

Waveforms can be displayed in divided windows to facilitate the viewing of multi-channel waveforms and computed waveforms. The screen can be divided into the following types.

Single (no division), Dual (two divisions), Triad (three divisions), Quad (four divisions), Octal (eight divisions), Hexadecimal (16 divisions).

**Waveform Mapping**

You can select the mapping of the input channels to the divided windows from the following.

Auto: The input channels that are turned ON are assigned in order by the channel numbers.

Fixed: The input channels are assigned in order by channel number regardless of whether the channels are ON/OFF.

User: The channels can be assigned arbitrarily to the divided windows regardless of whether the channels are ON/OFF.

**Display Interpolation <Section 8.2>**

In areas where less than 1000 points of data exist in the 10 divisions along the time axis (referred to as interpolation areas), a continuous waveform cannot be displayed because there is not enough sampled points. In this case, waveform is displayed by interpolating between data points. You can select the interpolation method from the following:

**Linear Interpolation**

Linearly interpolates between two dots.

**Sine Interpolation**

Generates interpolation data using the function  $\sin(x)/x$  then interpolates between two dots using the resulting sine curve. Sine interpolation is suitable for observing sine waves or similar waves.

**Interpolation OFF**

Displays discrete dots without performing interpolation.

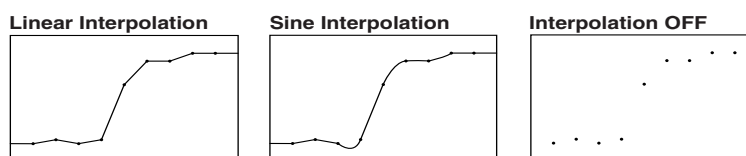
**All-Point Display and Decimation Display <Section 8.2>**

If the interpolation is OFF, waveforms are displayed using dots. In this setting, up to 2002 points or 100100 points (select either 2 k or 100 k points) of the acquired data are displayed without using P-P compression (see page 2-12). For example, if the number of displayed points is set to 100 k and the display record length is 10 kW (the number of acquired data points is 10010 points), all the points of the waveform are drawn by aligning 10 points vertically at the same time axis positions. If the number of acquired data points exceeds 2002 or 100100, the data is decimated down to 2002 or 100100 points (select either 2 k or 100 k points) for displaying the waveform.

## 2.4 Setting Waveform Acquisition Conditions and Display Conditions

### Graticule <Section 8.3>

You can change the type of graticule that is displayed to suit your needs. For example, you can show a grid on the screen or show only the frame.

### Accumulated Display <Section 8.4>

This mode holds each waveform on the screen for a time that is longer than the update cycle, so that newer waveforms appear overlapped on older waveforms. If you select Persist, the waveforms are accumulated using different colors. Accumulated display is useful when you want to observe jitters and temporary turbulence in waveforms.

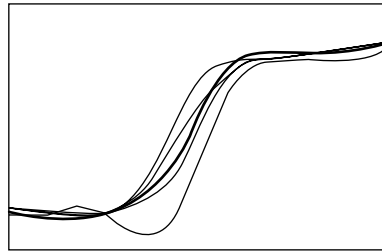

#### Note

Accumulated display is also possible on waveforms that are recalled using the history memory function.

### Extra Window <Section 8.11>

This area displays data such as cursor measurement values and values resulting from automated measurement of waveform parameters. The extra window is useful when reading of the values is difficult because waveforms are overlapping them.

### Scale Values <Section 8.9>

The upper and lower limits (scale values) of the vertical and horizontal axis of each channel can be displayed.

### Waveform Labels <Section 8.10>

A waveform label can be assigned arbitrarily to the input waveform of each channel using up to eight characters.

### Level Indicators and Numeric Values <Section 8.12>

Level indicator: The levels of each waveform is displayed using indication marks to the right of the waveform display frame.

Numeric values: Displays the measured value of each channel when in roll mode.

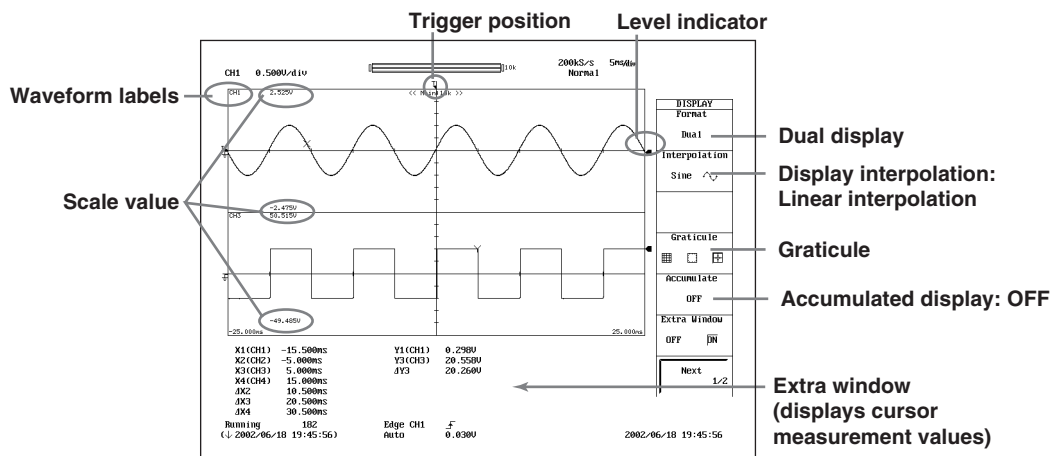

### Translucent Mode Display <Section 8.8>

The pop-up menu is shown translucent so that the display under the pop-up menu can be seen.

**Displaying the Channel Information and Expanding the Waveform Display Area**  
 <Section 8.13>

Pressing the ESC key once when the setup menu is displayed shows the channel information. The items that are displayed as channel information are as follows: However, some items may be skipped when the number of displayed channels increases.

- When measuring voltage: V/div setting, input coupling, probe attenuation (type), and bandwidth limit.
- When measuring temperature: Temperature/div setting, thermocouple type, and bandwidth limit.
- When measuring the strain:  $\mu$ STR/div (or [mV/V]/div) setting, measurement range, and bandwidth limit.
- When measuring acceleration: Acceleration/div setting, gain, input coupling, and bias setting.
- When measuring frequency: Value/div setting, measurement mode setting, and preset setting.
- DSP channel (optional): Value/div setting and computing equation.

Pressing the ESC key once when the channel information is displayed clears the channel information and shows the numeric monitor.

Pressing the ESC key once when the numeric monitor is displayed expands the waveform display area horizontally to cover the entire screen.

In addition, a setup menu of a single parameter may appear at the right corner of the screen when you press the SELECT key when the channel information or waveform monitor is displayed or when the waveform display area is expanded. The parameter controlled by the jog shuttle immediately before the channel information or numeric monitor was displayed or before the waveform display area was expanded is displayed here. This setup menu appears when you press the SELECT key only if there are items that can be controlled by the jog shuttle in the previous menu.

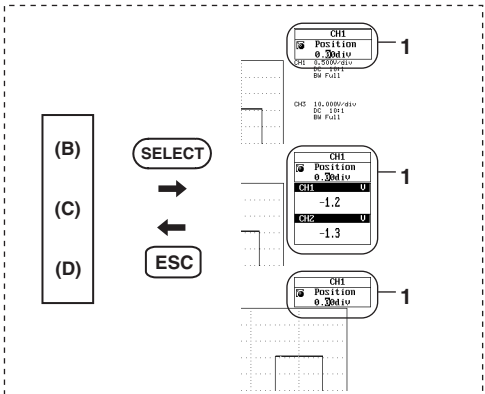
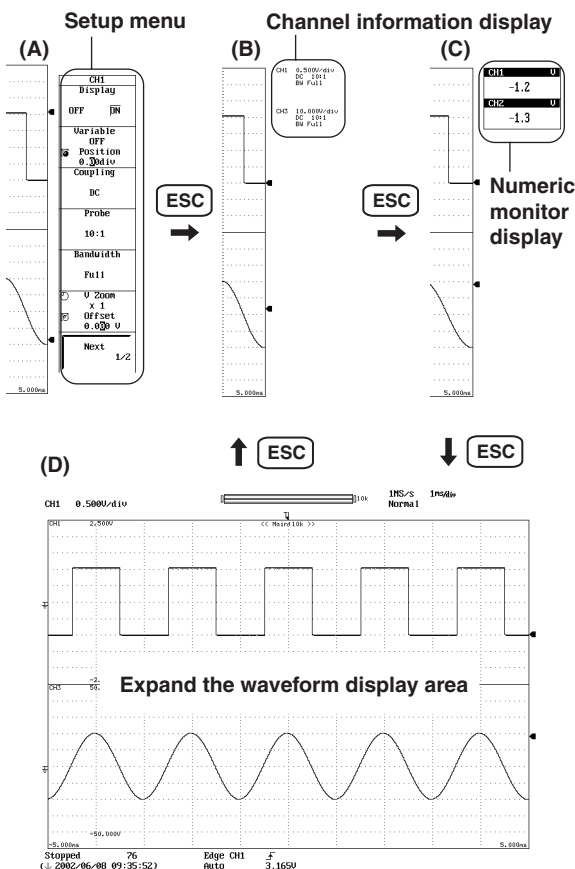

1. If there are two parameters in a single setup menu such as the Z1 Position and Z2 Position settings of the zoom rate (see section 8.5), the parameter controlled by the jog shuttle switches each time you press the SELECT key. The jog shuttle icon (⊖ or ⊕) is usually white, but it sometimes turns yellow. Yellow indicates that two parameters are selected simultaneously (controlled by the jog shuttle). Taking Z1 Position and Z2 Position as an example, pressing the SELECT key once selects Z1 Position. Pressing the SELECT key again selects Z2 Position. Pressing the SELECT key once more turns the icon yellow and the jog shuttle controls Z1 Position and Z2 Position. If you press the SELECT key yet again, the icon returns to a white color, and the jog shuttle controls only Z1 Position.

## 2.4 Setting Waveform Acquisition Conditions and Display Conditions

### X-Y Waveform Display <Section 8.6>

The voltage relationship between signals can be observed by assigning the voltage of the input signal of the specified channel on the horizontal axis (X-axis) and the voltage of another input signal (signal that has the display turned ON) on the vertical axis (Y-axis). Simultaneous observation of X-Y waveforms and normal T-Y waveforms (waveform display using voltage axis and time axis) is possible.









The channels that are assigned to the X and Y axes depending on the X-axis mode are as follows:

X-Axis Mode	X-Y Waveform	X-Axis	Y-Axis
Single		CH1 to CH16, DSP1 to DSP6, Math1 to Math8	All channels that are turned ON
Quad	XY1	CH1 to CH8, DSP1 to DSP3, Math1 to Math4	CH1 to CH8, DSP1 to DSP3, Math1 to Math4
	XY2	CH1 to CH8, DSP1 to DSP3, Math1 to Math4	CH9 to CH16, DSP4 to DSP6, Math5 to Math8
	XY3	CH9 to CH16, DSP4 to DSP6, Math5 to Math8	CH1 to CH8, DSP1 to DSP3, Math1 to Math4
	XY4	CH9 to CH16, DSP4 to DSP6, Math5 to Math8	CH9 to CH16, DSP4 to DSP6, Math5 to Math8

DSP1 to DSP6 are optional.

Using the X-Y waveform display function, you can measure the phase angle between two sine wave signals. For example, the waveform that appears when two sine waveforms are shown on the X-Y display is called a Lissajous waveform. From this waveform, the phase angle can be obtained.

Lissajous waveform

Phase angle 0°			
Phase angle 45°			
Phase angle 90°			
Frequency ratio (X:Y)	1:1	1:2	1:3

**Zooming in on the Waveform Horizontally <Section 8.5>**

The displayed waveform can be expanded along the time axis. This function is useful when the waveform acquisition time is set long and you wish to observe a particular section of the waveform in detail. Zooming is not possible if the number of displayed points on the screen is less than or equal to 10 (less than or equal to 50 for FFT waveforms). The zoom position is set in units of divisions of the grid.

**Display Format When the Waveform Is Zoomed**

Zoomed waveforms of two locations can be displayed simultaneously (dual zoom). Below are the display methods of zoom waveforms.

Main: Main waveform display frame  
Z1, Z2: Zoom waveform display frame

<Main>		<Main>		<Z1>		<Z1> or <Z2>	
<Z1> <Z2>		<Z1> or <Z2>		<Z2>			

When displaying Main (main waveform) and Z1 or Z2 (zoomed waveform) simultaneously, a zoom box indicating the zoom position is displayed within the main waveform display frame. The center of the zoom area corresponds to the center of the zoom box.

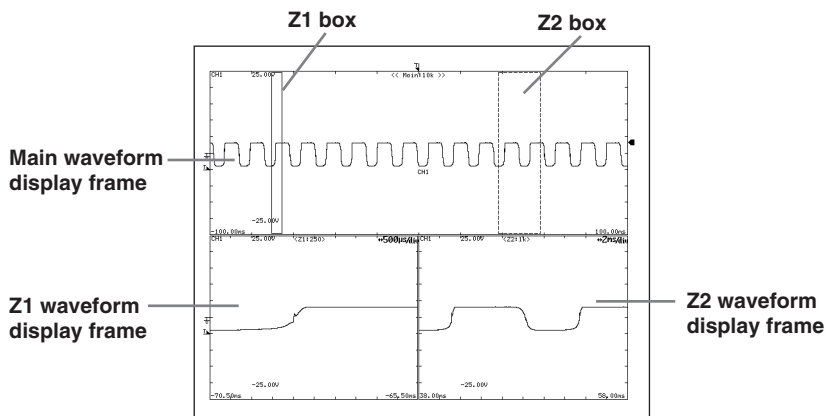

**Snapshot <Section 8.7>**

When the trigger mode is set to a mode other than single, the displayed waveforms are periodically updated or displayed in roll mode.

By using the snapshot function, you can temporarily hold the waveform that would be cleared when the screen is updated (snapshot waveform) on the screen. The snapshot waveform is displayed in white, allowing for easy comparison against the updated waveform. The snapshot waveform is a screen image waveform. You can save, load, and print the screen image data, but cursor measurements, automated measurement of waveform parameters, zoom, and computation cannot be performed on it.

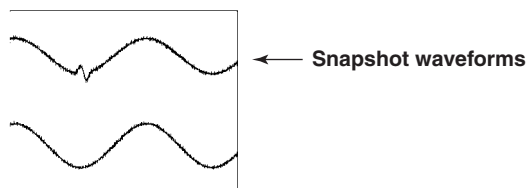

### Clearing Traces <Section 8.7>

You can clear the snapshot waveform, and restart averaging and accumulation with one key operation.

Pressing the CLEAR TRACE key temporarily clears the measured waveforms from the screen. Pressing the ESC key redisplay them.



## 2.5 Recording in Recorder Mode (Realtime Recording) (DL750P Only)

The DL750P is equipped with an A-4 size printer. If Chart Recorder mode is selected in the RECORDER menu and waveform acquisition is started, T-Y waveforms (T-Y waveform recording) or numeric values can be recorded in realtime. In addition, if X-Y Recorder mode is selected and waveform acquisition is started and stopped, the X-Y waveform over the interval in which waveform was acquired can be recorded (X-Y waveform recording).

### Chart Recorder Mode <Sections 9.2 to 9.6>

#### Print Style

In Chart Recorder mode, the print style can be selected from the following two styles.

#### **T-Y Waveform Recording**

In T-Y waveform recording, recording is performed at the specified chart speed (10 mm/h to 20 mm/s). The scale used in T-Y waveform recording is fixed to 10 mm per division on the horizontal axis (time axis). The scale on the vertical axis (voltage axis) can be set to 10 mm per division or [1 division of the 10 equally divided chart recording zone] per division. The recording can also be stopped automatically after recording a specified length (shot recording).

#### **Numeric Value Recording**

Numeric values can be recorded at the specified time interval (1 s to 60 min). Up to 16 channels can be recorded. If waveform acquisition is started on more than 16 channels, 16 channels are recorded in the following order: CH1 to CH6, DSP1 to DSP6 (option), LOGIC A, and LOGIC B.

#### Acquisition Mode during Chart Recorder Mode

During Chart Recorder mode, the acquisition mode is set to envelope. The acquisition mode cannot be changed with the ACQ key as with the normal operation. However, the acquisition mode can be changed to normal with the MISC menu. Select normal mode if you are using the acquired waveform as numeric data such as in an analysis.

#### Selectable Trigger Modes in Chart Recorder Mode

The following four trigger modes can be selected.

#### **Auto**

Recording on the built-in printer starts at the same time measurement is started by pressing the START/STOP key. Recording continues until measurement is stopped by pressing the START/STOP key again. The maximum number of divisions of the most recent data that can be saved (see page 2-45) is saved in the internal memory.

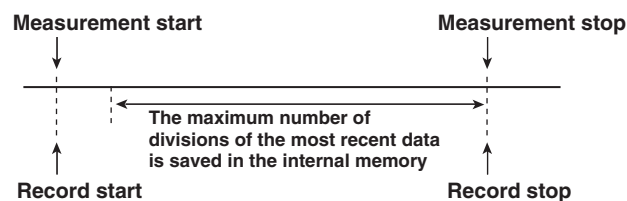

**2.5 Recording in Recorder Mode (Realtime Recording) (DL750P Only)**

**Log**

Recording on the built-in printer starts at the same time measurement is started by pressing the START/STOP key. Measurement and recording stops automatically when the maximum number of divisions of measured values that can be saved is recorded. The maximum number of divisions of measured data that can be saved is saved in the internal memory.

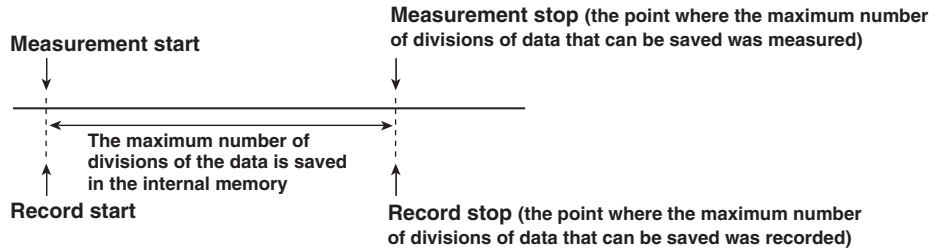

**Single (Only during T-Y Waveform Recording)**

Recording on the built-in printer starts when the trigger condition is met after measurement is started by pressing the START/STOP key. The data is saved to the internal memory at the same time recording is started. Measurement and recording stops when the maximum number of divisions of measured values that can be saved is recorded. The maximum number of divisions of measured data that can be saved is saved in the internal memory.

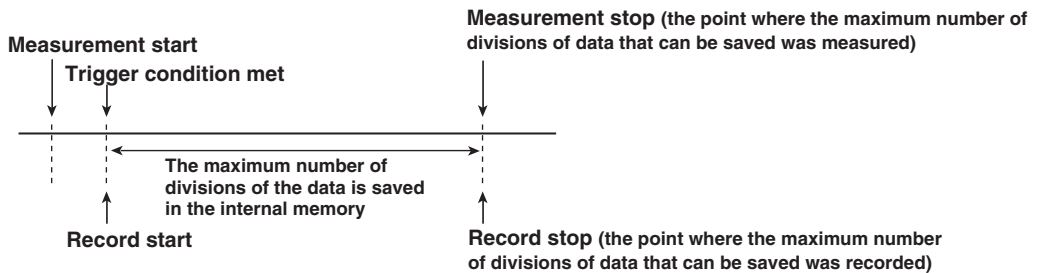

**Repeat (Only during T-Y Waveform Recording)**

Recording on the built-in printer starts when the trigger condition is met after measurement is started by pressing the START/STOP key. The data is saved to the internal memory at the same time recording is started. Recording stops when the shot record length of measured values is recorded. Then, the DL750P enters the trigger-wait state. The most recent shot record length of measured data is saved to the internal memory.

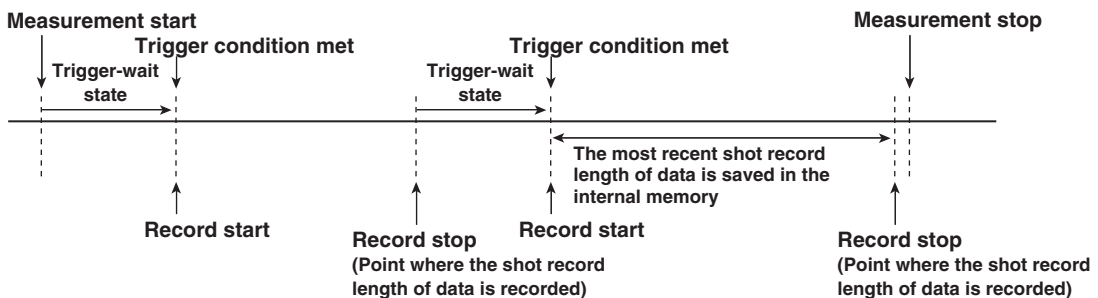

**Saving Data in the Internal Memory**

In Chart Recorder mode, up to 1000 divisions of the recorded data are automatically saved in the internal memory. The required section of the data that has been cleared from the screen can be redisplayed after the recording is finished by using functions such as search & zoom (limited to the data in the range defined by “Number of Data Points That Can Be Saved” below). As with the normal data (data when the recorder mode is OFF), cursor measurements, automated measurement of waveform parameters, normal statistical processing\*, search & zoom, and display setting modification in the DISPLAY menu can be performed on the redisplayed data. The redisplayed data can also be saved as waveform data in the same fashion as normal data. Furthermore, the redisplayed data can be reprinted by changing the print conditions or a PDF file of the reprint image can be created (see “Reprinting on the Built-in Printer” or “Creating a PDF File of the Reprinted Image” on page 2-46).

\* Cycle statistical processing and statistical processing of history data cannot be performed in Chart Recorder mode.

**Number of Data Points That Can Be Saved**

If the chart speed is slow, the number of data points that can be saved in the internal memory is reduced. For example, if the chart speed is 10 mm/h, up to 100 divisions of data (up to 4 days of data) are saved. If the chart speed is 20 mm/s, up to 1000 divisions of data (up to 8 minutes 20 seconds of data) are saved. The maximum number of divisions that can be saved for each chart speed is as follows:

Chart Speed	Maximum Number of Divisions That Can Be Saved
20 [mm/s] to 1 [mm/s]	1000
100 [mm/min] to 2 [mm/min]	1000
1 [mm/min]	500
100 [mm/h]	1000
50 [mm/h]	500
25 [mm/h]	250
20 [mm/h]	200
10 [mm/h]	100

For the relationship between the chart speed and sample rate, see appendix 15.

**Functions That Cannot Be Used in Chart Recorder Mode**

When making measurements in Chart Recorder mode, history memory, GO/NO-GO determination, dual capture, and waveform computation cannot be used. (The HISTORY, GO/NO-GO, DUAL CAPTURE, and MATH keys cannot be used.) In addition, items set with the ACQ key cannot be changed.

**Compatibility with the Measured Data**

The measured data in Chart Recorder mode is not compatible with the measured data when the recorder mode is OFF. The measured/saved data in Chart Recorder mode cannot be loaded with the recorder mode turned OFF, and vice versa. The measured data on the DL750 and the measured data on the DL750P (when the recorder mode is OFF) are compatible.)

### **X-Y Recorder Mode <Section 9.7>**

#### **X-Y Waveform Recording**

In X-Y waveform recording, the X-Y waveform starts to be displayed when waveform acquisition is started. If reprint is executed from the Reprint Setup menu after the record length of waveform (fixed to 1 MW) is acquired or after stopping waveform acquisition, the X-Y waveform acquired up to the point immediately before the measurement was stopped is recorded on paper.

The scale of the X-Y waveform recording is 10 mm per division for both X- and Y-axes, and the waveform recording area is  $\pm 10$  divisions (20 divisions). The screen also shows the X-Y waveform. Recording to paper can also be started automatically when waveform acquisition is stopped (auto print).

#### **Acquisition Mode during X-Y Recorder Mode**

The acquisition mode is automatically set to normal during X-Y record mode. The acquisition mode cannot be changed with the ACQ key as with the normal operation.

#### **Saving Data in the Internal Memory**

In X-Y recorder mode, up to 1 MW of data is automatically saved in the internal memory. Also, a PDF file of the reprint image can be created.

#### **Functions That Cannot Be Used during X-Y Recorder Mode**

When making measurements in X-Y Recorder mode, history memory, GO/NO-GO determination, dual capture, and waveform computation cannot be used. (The HISTORY, GO/NO-GO, DUAL CAPTURE, and MATH keys cannot be used.) In addition, items set with the ACQ key cannot be changed.

#### **Compatibility with the Measured Data**

The measured data in X-Y Recorder mode is not compatible with the measured data when the recorder mode is OFF. The measured/saved data in X-Y Recorder mode cannot be loaded with the recorder mode turned OFF, and vice versa. The measured data on the DL750 and the measured data on the DL750P (when the recorder mode is OFF) are compatible.)

### **Reprinting on the Built-in Printer (Only during T-Y Recording) <Section 9.8>**

After the T-Y recording in Chart Recorder mode is finished, the data stored in the internal memory can be recalled and reprinted by changing the print conditions.

### **Creating a PDF File of the Reprint Image (Only during T-Y Recording) <Section 9.9>**

After the waveform recording in Chart Recorder mode or X-Y Reorder Mode is finished, the data stored in the internal memory can be recalled and a PDF file of the reprint image can be created.

In X-Y Recorder Mode, the most recent 1 MW of data stored in the internal memory are output to the PDF file. If data exceeding 1 MW is recalled, the waveform displayed on the screen and the waveform recorded on the printer may differ from the waveform output to the PDF file.

## 2.6 Waveform Computation

Various computations can be performed on up to 800 kW of data on the DL750/DL750P. (If a waveform greater than 800 kW is displayed, computation cannot be performed over all the data at once.) The computed results become Math1 to Math8 waveforms.

### Addition, Subtraction, Multiplication, and Division <Section 10.1>

Addition, subtraction, multiplication, and division can be performed between two arbitrary waveforms of CH1 to CH16 and Math1 to Math8. These computations are useful in the following cases.

Addition and subtraction: Comparison with the standard signal, confirmation of the signal logic, phase comparison, etc.

Multiplication and division: Confirmation of the power waveform by applying the voltage and current signals, etc.

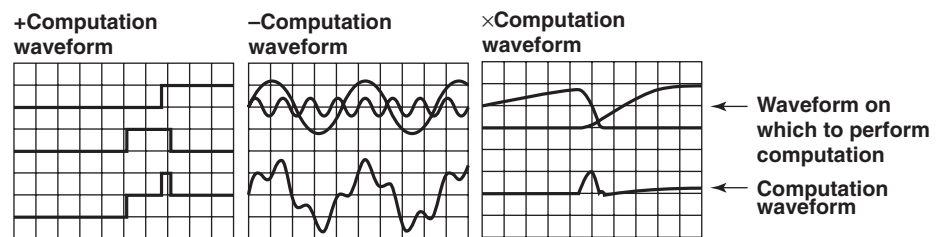

### Binary Computation <Section 10.2>

The specified waveform is converted to a digital waveform of 0s and 1s with respect to the specified threshold level. The computation can be performed on CH1 to CH16 and Math1 to Math7.

### Power Spectrum Display <Section 10.3>

The power spectrum of the input signal can be displayed by taking the FFT (Fast Fourier Transform). This is useful when you wish to check the frequency distribution of the input signal.

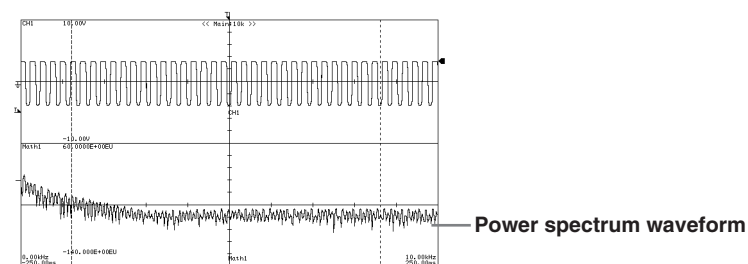

You can select the FFT window from the following three types.

#### Rectangular (Rect)

Best suited to transient signals, such as an impulse wave, which attenuate completely within the time window.

#### Hanning and FlatTop

The Hanning and flattop windows allow continuity of the signal by gradually attenuating the parts of the signal located near the ends of the time window down to the 0 level. Hence, it is best suited to continuous signals. With the Hanning window, the frequency resolution is high as compared with the flattop window. However, the flattop window has a higher level of accuracy. When the waveform being analyzed is a continuous signal, select the proper window for the application.

## 2.6 Waveform Computation

### Exponential Window

The exponential window eliminates noise components from the signal. It can be selected only when the user-defined computation option is installed. It is effective against frequency response test signals generated through impulse excitation.

For details on each window, see page app-21.

FFT is performed on 1000, 2000, 5000, 10000, 20000, 50000 or 100000 points of measured data. The data is converted to half the specified number of points and displayed.

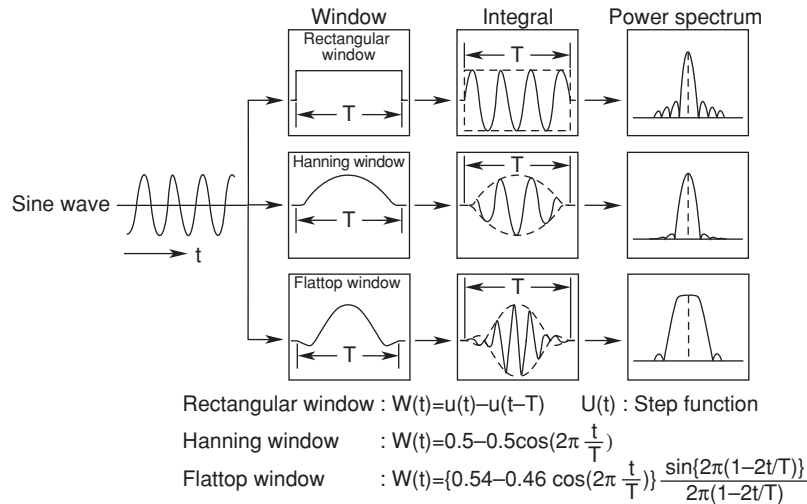

### FFT Function

Given that the complex function resulting after the FFT is  $G = R + jI$ , the power spectrum can be expressed as follows.

$$\text{Power spectrum} = 10 \log \left( \frac{R^2 + I^2}{2} \right)$$

R: Real Part, I: Imaginary Part

Reference value (0 dB) of the logarithmic magnitude (Log mag): 1 Vrms<sup>2</sup>

### Phase Shift (Phase Mode) <Section 10.4>

You can shift the phase of CH1 to CH16, Math1 to Math7, and DSP1 to DSP6 (optional) waveforms and display the resultant waveforms or perform computation using the phase-shifted data.

### User-Defined Computation (Optional) <Section 10.5>

You can define computing equations by combining the following operators:

+, -, \*, /, SHIFT (phase shift), ABS (absolute value), SQRT (square root), LOG (logarithm), EXP (exponent), NEG (negation), SIN (sine), COS (cosine), TAN (tangent), ATAN (arctangent), PH (phase), DIF (differentiation), DDIF (2nd order differentiation), INTG (integral), IINTG (double integral), BIN (binarization), P2 (square), P3 (cube), F1 ( $\sqrt{|C1^2 + C2^2|}$ ), F2 ( $\sqrt{|C1^2 - C2^2|}$ ), FV (inverse of the pulse width PHWW), PWHH (pulse width), PWHL (pulse width), PWLH (pulse width), PWLL (pulse width), PWXX (pulse width), DUTYH (duty ratio), DUTYL (duty ratio), FILT1 (digital filter), FILT2 (digital filter), HLBT (hilbert), MEAN (moving average), LS- (linear spectrum), PS- (power spectrum), PSD- (power spectrum density), CS- (cross spectrum), TF- (transfer function), CH- (coherence function), variable (T), and constants (K1 to K8). In addition, you can average or compute the peak value on the computed data. The following four operations are available.

### Linear Averaging

The values are summed linearly the number of average counts (the number of acquisitions, 2 to 128, 2<sup>n</sup> steps) and divided by the average count. The resultant waveform is displayed. For the equation, see "Acquisition Mode" on page 2-31.

**Exponential Averaging**

The average is determined by attenuating the effects of past data according to the specified attenuation constant (2 to 256, in 2<sup>n</sup> steps). The resultant waveform is displayed. For the equation, see section “Acquisition Mode” on page 2-31.

**Cycle Averaging**

Divides one period of computed data into the specified number of data points (Cycle Count). This is done across multiple periods of data from the start to the end position of the computation. Then, the average of the data points at the same position across multiple periods is determined. The resulting waveform is displayed. The following figure shows the result of the cycle average when Cycle Count is set to 720.

<Computed data>

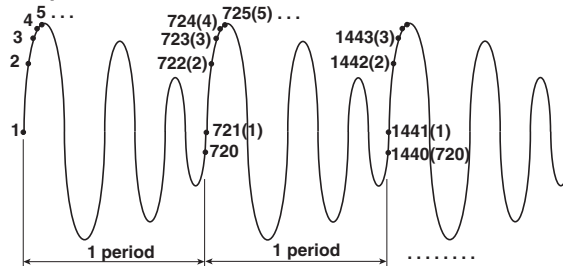

<Result of cycle average>

Determines the simple average of the computed data at the same position across multiple periods and displays the waveform.

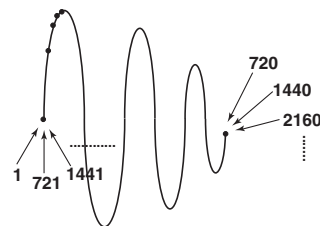

**Peak Computation**

Determines the maximum value at each point of the computed data and displays the waveform. For each computation, the new computed value is compared with the past value and the larger value is kept.

3 sets of FFT data

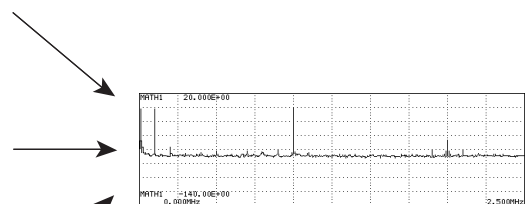
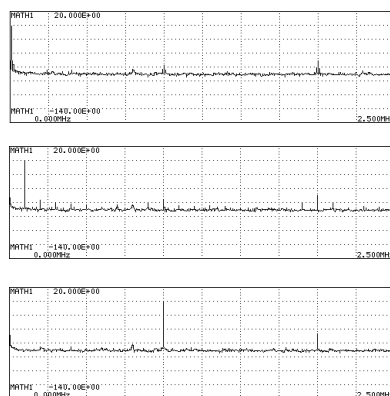

Displays the maximum value of each point

**Scaling of Computed Waveforms <Chapter 10>**

The DL750/DL750P normally performs auto scaling when displaying computed waveforms. However, you can also select manual scaling. When auto scaling, the upper and lower limits suitable for displaying the waveform are determined from the first computed waveform and other parameters. If you select manual scaling, you can arbitrarily set the upper and lower limits of the computed waveform display.

DSP Channels <Chapter 15>

**What DSP Channels Are**

DSP (Digital Signal Processor) channels are used to perform computations between channels and filter computations in realtime using the output data of the input module as the source. Below are the characteristics of DSP channels.

- Performs relatively simple computations such as the addition, subtraction, multiplication, and division (+, −, ×, and ÷) between channels, 4 types of digital filters, differentiation, and integration.
- The computation source of DSP channels is 16 bits. However, internally, the value is converted into a floating-point decimal number for performing computations. The computed result is converted into 16-bit data assigned by the range value (Value/Div), and then stored to the memory. (For a description of the computation format, see appendix 6.) The display is based on 2400 LSB/div (same as the 16-bit analog module).
- There are four selectable digital filter formats (sharp, Gauss, IIR (Butterworth), and moving average) and three selectable digital types (LPF, HPF, and BPF). The characteristics of each filter are indicated below.

Filter Format	Characteristics	Filter Type	Computation Type
SHARP	Steep attenuation slope (−40 dB per octave) Linear phase and constant group delay Ripple exists in the passband Stop band is comb-shaped	LPF <sup>1</sup> HPF <sup>1</sup> BPF <sup>1</sup>	FIR
GAUSS	Gentle attenuation slope Linear phase and constant group delay No ripple in the passband There is no overshoot in the step response. Low order and small delay	LPF	FIR
MEAN (Moving Average)	Comb-shaped characteristics Linear phase and constant group delay There is no overshoot in the step response.	LPF	FIR
IIR (Butterworth)	Attenuation slope is between SHARP and GAUSS Not linear phase and group delay not constant No ripple in either passband or stopband Close to the characteristics of an analog filter Cutoff frequency can be set lower than SHARP/GAUSS	LPF HPF BPF	IIR

1. LPF, HPF, and BPF denote low-pass filter, high-pass filter, and bandpass filter, respectively.

- The cutoff frequency, center frequency, and pass band of the digital filter are set in terms of percentages of the fs (sampling frequency).
- The sampling frequency varies depending on the T/div and record length settings. The maximum sample rate is 100 kS/s (6 channels simultaneously). At sample rates above 100 kS/s, data is automatically re-sampled at 100 kS/s. In envelope mode, data is always sampled at 100 kS/s. (Note that the sampling frequency of the digital filter always follows the behavior described above.)
- High speed because computation is performed at the stage before the waveform is acquired (stage before the data enters the acquisition memory).
- Displays waveforms in realtime even during roll mode display.
- Various computation parameters such as the cutoff frequency of the digital filter can be changed while waveform is being acquired.
- Triggers can be activated on the computed result.
- Same record length as analog channels (achieves long memory).
- 16 analog channels + 6 computed waveform channels of DSP channels = 22 channels can be displayed simultaneously.



- The computed result of a DSP channel can be defined as a computation source of another DSP channel. However, in this case, the computation delay is accumulated. To avoid recursive reference in the computation, the channel that you can specify as a computation source is a DSP channel with a smaller channel number than itself. (Example: The selectable DSP channel on DSP channel 2 is DSP channel 1; the selectable DSP channels on DSP channel 3 are DSP channels 1 and 2.)
- The computation delay is equal to 4 samples + the computation delay of the digital filter. For details on the computation delay of the digital filter, see appendix 6.
- The range (Value/Div) of the DSP channel is automatically set to the optimum range by evaluating the range value of the input source and the computing equation when you press the Optimize Value/Div soft key. (However, since the range does not track the input value or the computed result, you must adjust the Value/Div setting using the V/DIV knob as described below.)
- You can change the range value (Value/Div) of the DSP channel using the V/DIV knob.
- A total of 123 Value/Div ranges between  $500.0E+18$  and  $10.00E-21$  (1-2-5 steps) are supported to accommodate the dynamic range of the computed result.
- The input and output of DSP channels are 16-bit binary data (if the input is 12 bits, it is converted to 16 bits). For details on the internal processing, see "Computation Flow and Internal Computation Format of DSP Channels" in appendix 6.

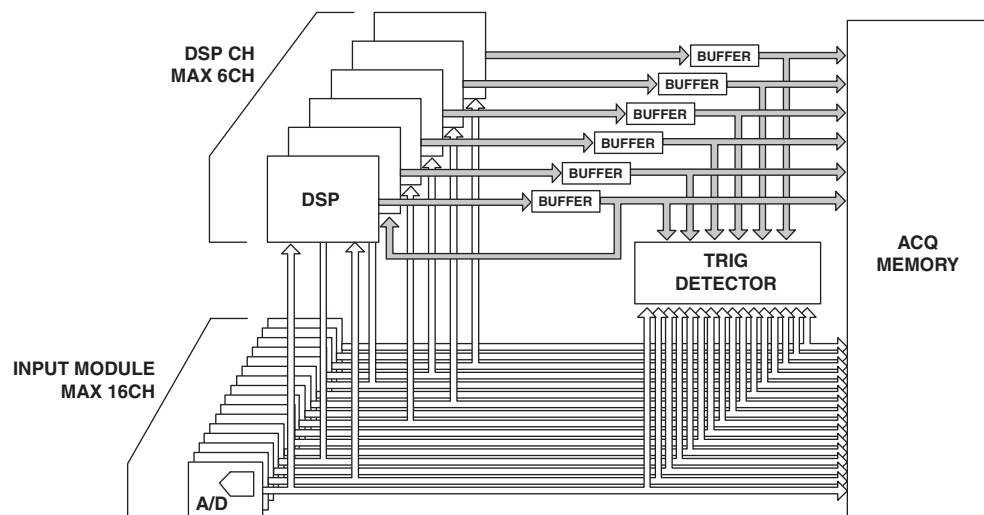

**Difference between Normal Computed Waveforms (Math1 to Math8) and DSP Channels (DSP1 to DSP6)**

**Normal Computed Waveforms (Math1 to Math8)**

- Since the computation is performed after acquiring the waveform, the interval of continuous measurements is long.
- Computation is not possible during roll mode display.
- Since the computed result is stored in the main memory of the main CPU, there is a limitation on the record length.
- Triggers cannot be activated on the computed result.
- Various computing equations are supported, because a general-purpose CPU is used.

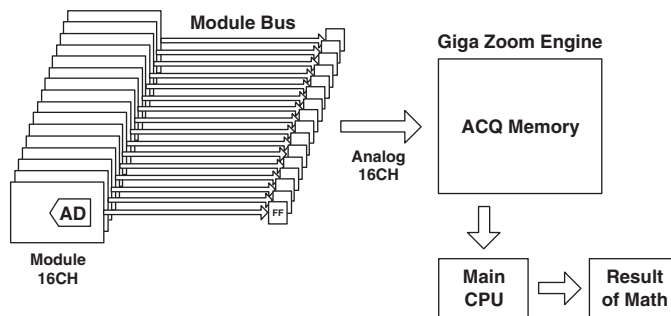

**DSP Channels (DSP1 to DSP6)**

- Realtime computation can be performed while waveforms are being acquired.
- Computed results can be monitored even during roll mode display.
- There is no limitation on the record length. The record length can be set to the same length as normal analog input channels.  
 Example The record length of CH1 of the analog input channel is 10 MW and the record length of the DSP channel is 10 MW.  
 The selectable DSP channel on DSP channel 2 is DSP channel 1; the selectable DSP channels on DSP channel 3 are DSP channels 1 and 2.)
- Triggers can be activated on the computed result.
- Computation rate is 100 kS/s.
- Addition, subtraction, multiplication, and division (with or without coefficients), filtering, differentiation, integration, and knocking filtering can be performed.
- Can be used in all acquisition modes (including the dual capture function).
- Acquisition rate is fast, because there is no processing after waveform acquisition.

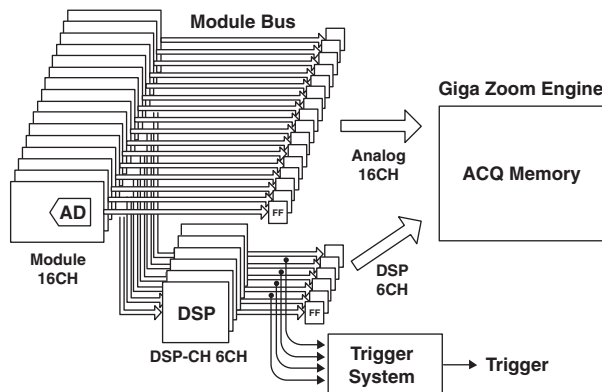

## 2.7 Waveform Analysis/Search

### Displaying History Waveforms <Section 11.1>

Past waveform data (history waveforms) stored in the acquisition memory can be displayed when waveform acquisition is stopped. You can display a specified history waveform from the data (up to 2000 waveforms, or the number of triggers) stored in the acquisition memory.

The number of waveforms N that can be acquired and held as history waveforms varies from 1 to 2000 depending on the record length and acquisition mode settings. The waveform currently displayed on the screen (newest waveform) is counted as the 1<sup>st</sup> waveform, and up to N-1 waveforms in the past can be displayed.

### History Search Function <Sections 11.2 and 11.3>

You can search waveforms that match specified conditions from the waveform data in the history memory.

#### Search by Zone

From the waveforms stored in the history memory, waveforms that passed or not passed a specified area (zone) can be searched.

#### Waveform stored in the history memory

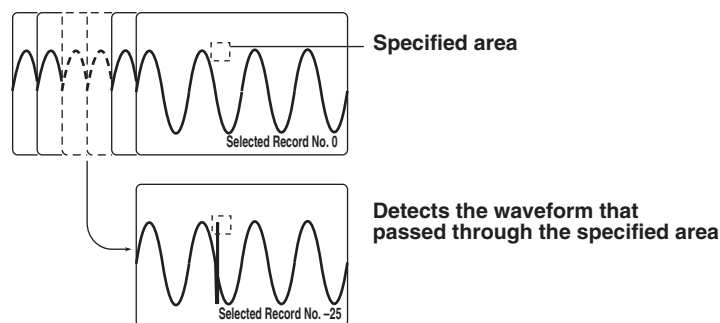

#### Search by Waveform Parameters

From the waveforms stored in the history memory, waveforms that meet or do not meet the specified parameter conditions can be searched.

#### Waveform that was saved using the history memory function

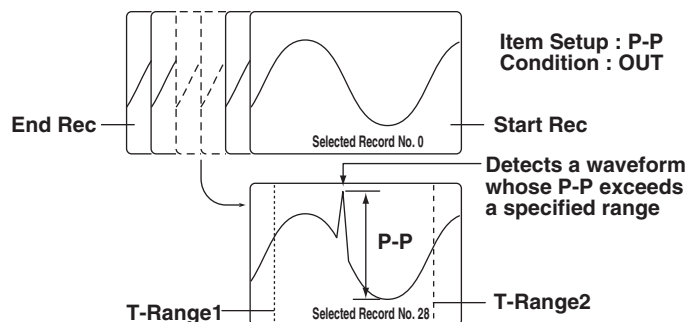

### Search and Zoom Function <Section 11.4>

#### Edge Search

Searches the position where the signal went over (rising) or below (falling) the specified level the specified number of times from the search start position. The waveform expanded around the found position can be displayed in the zoom window. The search target is CH1 to CH16, DSP1 to DSP6, LOGIC A, and LOGIC B.

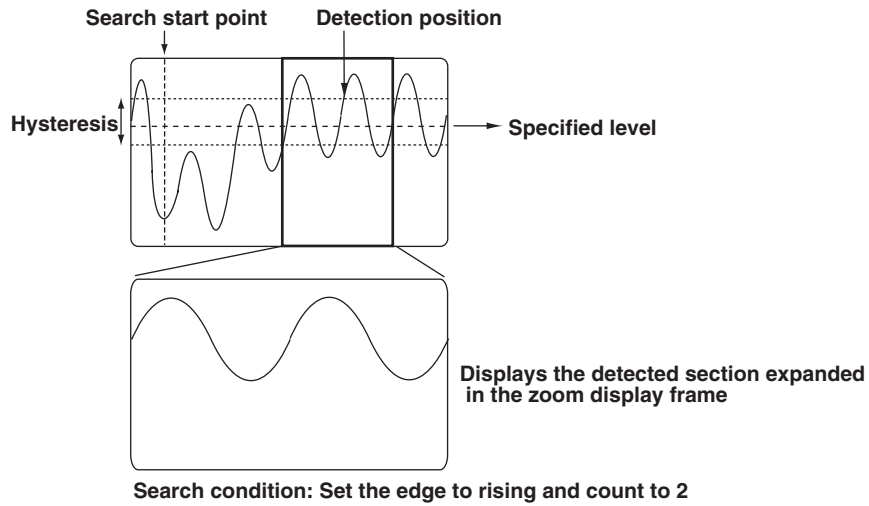

#### Auto Scroll

The zoom position automatically moves in the specified direction. You can scroll through the zoomed waveform and stop the scrolling at the desired position.

#### Voice Search

Searches the start point of the voice memo that has been recorded using the voice memo function (see section 7.9). Playing the voice memo that has been found is also possible.

### Cursor Measurement <Section 11.5>

The following cursors are available for analyzing the values of each waveform data.

#### H (Horizontal) Cursors

Two broken lines (H cursors) are displayed on the X-axis (horizontal axis). The voltage of each H cursor and the voltage difference between the H cursors are measured.

#### V (Vertical) Cursors

Two broken lines (V cursors) are displayed on the Y-axis (vertical axis). The time from the trigger position to each V cursor and the time difference between the V cursors are measured. The voltage value of the signal at each cursor position, and the voltage difference between the cursors are also measured.

#### H&V Cursors

H cursors and V cursors are displayed simultaneously.

#### Marker Cursors

Four markers are displayed on the specified waveform. The voltage and the time from the trigger position of each marker as well as the voltage difference and time difference between markers are measured.

#### Degree Cursors

Measures the angle between two angle cursors with respect to a reference angle corresponding to the width between the zero point and the end point, which are measurement references.

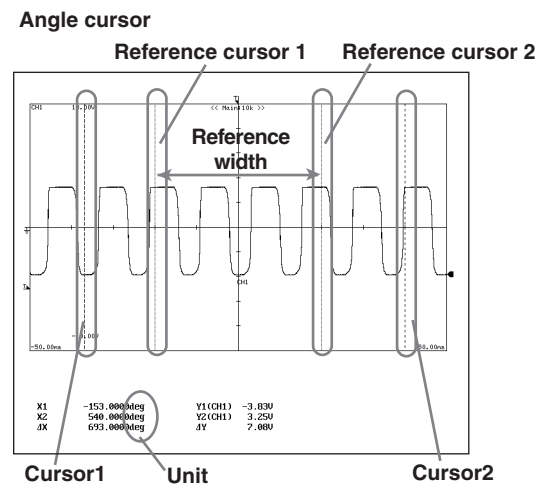
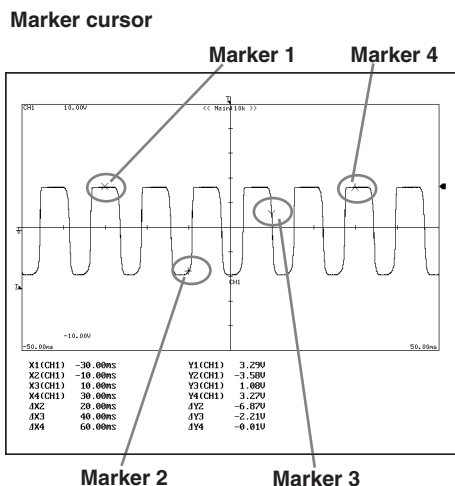
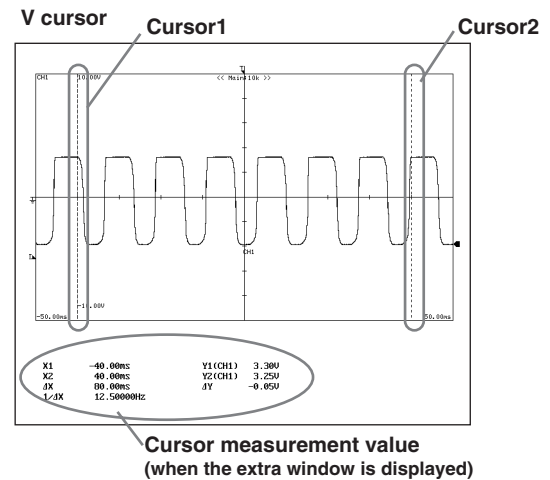
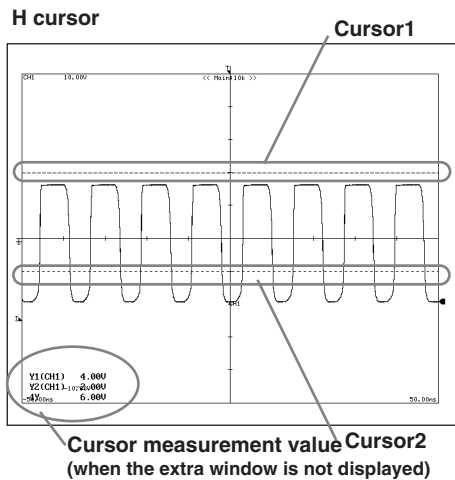

**Automated Measurement of Waveform Parameters <Section 11.6>**

Automated measurement can be performed on parameters such as the rise time and pulse width on the specified channel. There are 29 measurement parameters. Up to 24 parameters from the selected parameters of all channels can be displayed. The measurement range is up to 10 MW from the measurement start point (Time Range1).

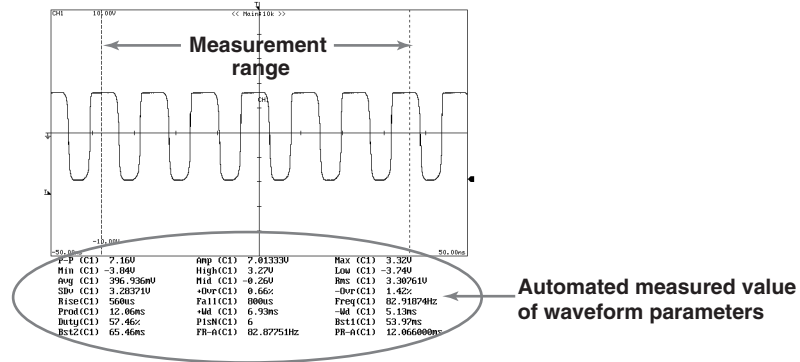

**Statistical Processing <Section 11.7>**

Statistical processing is performed on the measured values of automated waveform parameters described on the previous page. The following five statistics are determined on the three measured values of automated measurement parameters. The number of measured values used to determine the maximum value, minimum value, average value, standard deviation, and statistical processing.

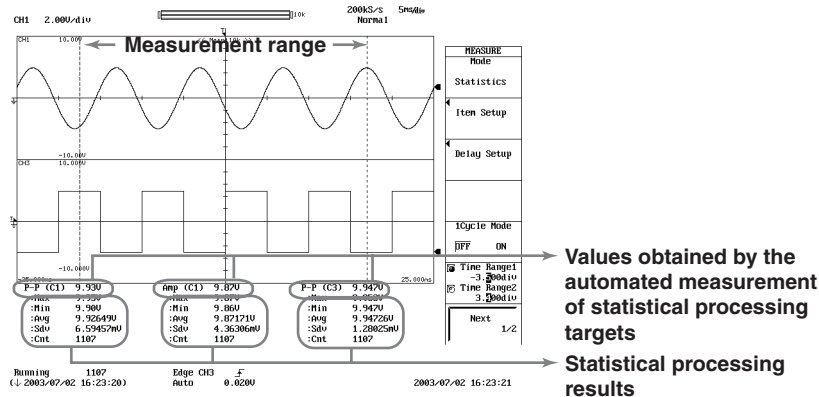

The following three statistical processing modes are available.

**Normal Statistical Processing**

Statistical processing is performed on all acquired waveforms while acquiring waveforms.

**Cycle Statistical Processing**

Divides the displayed waveform using a cycle that is automatically calculated and determined and performs statistical processing on the values obtained through the automated measurement of waveform parameters over the determined cycle. Statistical processing is performed from the oldest measured data of the displayed waveform. Statistical processing of up to 48000 measured values of automated waveform parameters is possible. If statistical processing is performed on 1 parameter, statistical processing of up to 48000 cycles is possible.

Example in which CH1 is selected as the waveform used to determine the cycle

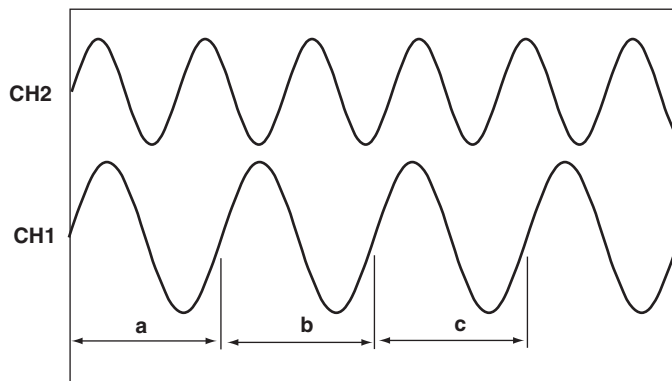

Automated measurement parameters are measured in each range, a, b, and c, and statistical processing is performed on the automated measurement parameters in the order a, b, and c.

The automated measurement parameters of other channels are also measured using ranges a, b, and c.

Automated measurement can also be made using the cycle of each waveform as the range.

**Statistical Processing of History Data**

Performs automated measurement of waveform parameters on the waveform that is acquired using the history memory function and performs statistical processing. Statistical processing is performed from the oldest waveform.

### GO/NO-GO Determination <Sections 11.8 to 11.10>

The GO/NO-GO function is useful when you want to inspect signals and track down abnormal symptoms on a production line making electronic equipment. The function determines whether the waveform is within the preset range and performs a specific action for a GO or NO-GO result. There are two types of determinations.

- **Zone:** Method in which a waveform zone is set on the screen
- **Parameter:** Method in which a waveform parameter range is specified

The following five types of actions can be performed for GO or NO-GO result.

- **Print the Screen Image Data (PRINT)**  
Prints the screen image data to a specified printer.
- **Save the Screen Image Data (Image)**  
Saves the screen image data to the save destination specified in the FILE menu.
- **Save the Waveform Data (Save to File)**  
Saves the waveform data in binary, ASCII, or floating format to the save destination specified in the FILE menu.
- **Beep Sound (Buzzer)**  
Sounds a buzzer.
- **Send Mail**  
Sends an e-mail message to a specified address. (when the Ethernet interface option is installed)

In addition, the determination result can be output externally using signals.



## 2.8 Communications

### Command (GP-IB, Serial (RS-232), USB and Ethernet Communications) <Communication Interface User's Manual>

The DL750/DL750P comes standard with GP-IB, serial (RS-232), and USB interfaces. The Ethernet interface is available as an option. Through communication functions, you can output waveform data to a PC for data analysis or control the DL750/DL750P using an external controller to carry out waveform measurements.

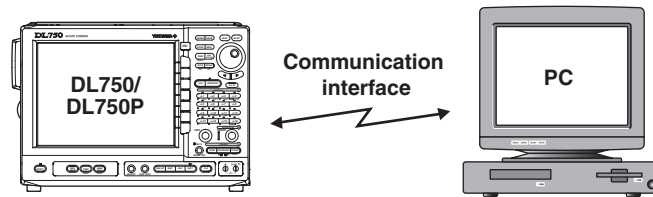

### Saving/Loading Data to a Network Drive (FTP Client Function) <Chapter 16>

Waveform<sup>1</sup> data, screen image data, and setup data can be saved, deleted, or copied on an FTP server<sup>2</sup> on the network in the same fashion as the built-in floppy disk, built-in Zip disk (DL750 only), built-in PC card, internal hard disk (optional), or external SCSI device.

1. The following types of waveform data cannot be loaded from a network drive.
  - Waveform data that is 50 MB or more in size.
  - Waveform data saved on the all waveform display (All) of the history memory function.
2. PC or workstation on which the FTP server function is running.

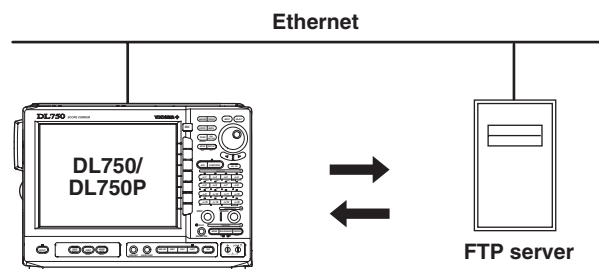

### Printing Screen Image Data on a Network Printer <Section 16.4>

The screen image data can be printed on a network printer in the same way as the built-in printer or USB printer.

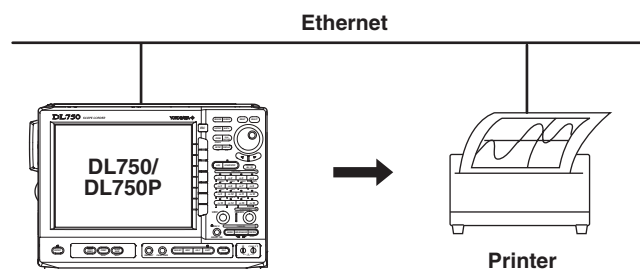

**Transmitting E-mail Messages (SMTP Client Function) <Section 16.5>**

The information of the DL750/DL750P can be transmitted periodically in an e-mail message to a specified mail address. You can also transmit information such as the trigger time as an action for the GO/NO-GO determination or action-on-trigger.

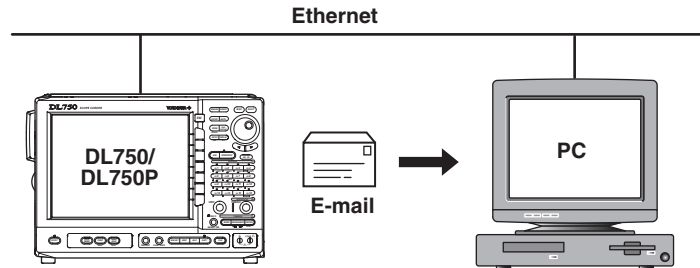

**Accessing the DL750/DL750P from a PC or Workstation (FTP Server Function) <Section 16.6>**

The files on the built-in floppy disk, built-in Zip disk (DL750 only), built-in PC card, internal hard disk (optional), or external SCSI device on the DL750/DL750P can be retrieved by accessing the DL750/DL750P from an FTP client<sup>1</sup> on the network.

- 1. PC or workstation on which the FTP client function is running.

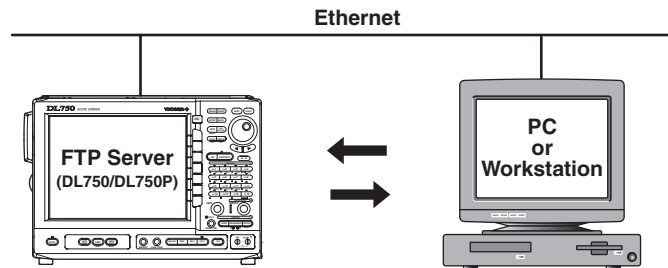

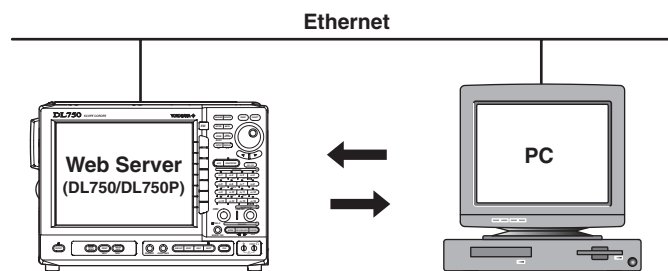

**Web Server Function <Section 16.7>**

The DL750/DL750P can function as a Web server. By using the Web page of the DL750/DL750P, file transfer, monitoring of displayed waveforms, basic DL750/DL750P key control, and retrieval of waveform data are possible.



## 2.9 Other Useful Functions

### Entering Values Directly from the NUM Keys <Section 4.2>

For items with  or  icon on the menu, you can press the NUM KEY and enter values using the CH1 to CH16 keys of the VERTICAL group as 0 to 9, . (decimal point), ±, m (milli), μ (micro), and ENTER keys. The gray value or character marked below and to the left of each key can be entered.

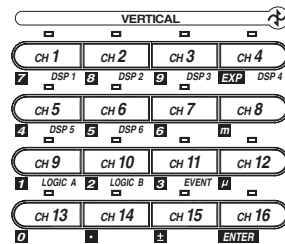

**Example: When entering 1.5 mV**  
Press the keys in the following sequence:  
CH9 (1), CH14 (.), CH6 (5), CH8 (m),  
and CH16 (ENTER).

### Entering Values and Strings from a USB Keyboard <Section 4.2>

You can connect a USB keyboard for entering file names, comments, and other information. In addition, the functions of each key on the front panel of the DL750/DL750P are assigned to the keys on the keyboard. Thus, the keyboard can be used to carry out operations that are the same as the key operations on the DL750/DL750P. For the key assignments, see appendix 8, “Table of Key Assignments of the USB Keyboard.”



### Operations Using a USB Mouse <Section 4.2>

You can use a USB mouse to operate the DL750/DL750P as you would using the front panel keys. In addition, you can point to a desired item on a menu and click the item. This is analogous to pressing a soft key corresponding to a menu and pressing the SELECT key.

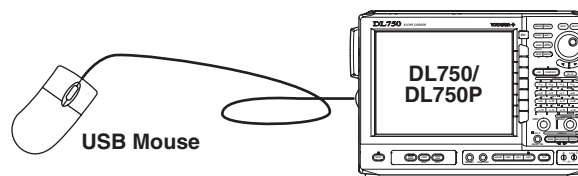

### Initialization <Section 4.4>

The settings of each key can be reset to their initial conditions. However, date and time settings, communication settings, and SCSI ID setting are not initialized. To reset the communication-related and SCSI ID settings to factory default, turn ON the power while holding down the RESET key. Release the RESET key after a beep sound is heard. (Date and time settings cannot be reset.)

### Auto Setup <Section 4.5>

This function automatically sets the voltage axis, time axis, trigger settings, and other settings to suit the input signal. This is useful when the characteristics of the input signal are unknown. However, the auto setup function may not work depending on the input signal.

### Printing the Screen Image Data <Chapter 12>

The screen image data can be printed on the built-in printer (option), USB printer, or network printer (when the Ethernet interface option is installed).

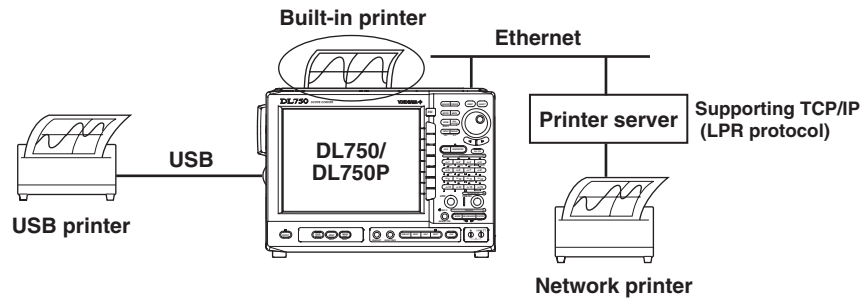

---

#### Note

There is a function that enables comments to be entered using a keyboard that appears on the screen or a USB keyboard and displayed on the screen. You can enter a comment describing the displayed waveform before printing the screen image data. This is useful in identifying the printed matter.

---

### Saving and Loading Various Data on the Storage Medium <Chapter 13>

The DL750/DL750P allows various data to be stored to and loaded from the following storage media.

- Floppy disk, Zip disk (DL750 only), or PC card (one type is selected at the time of purchase)
- Internal hard disk (option)
- External USB storage device (MO disk, hard disk, or flash memory)
- External SCSI device (MO disk, Zip disk, etc.)
- Network drive (when the Ethernet interface option is installed)

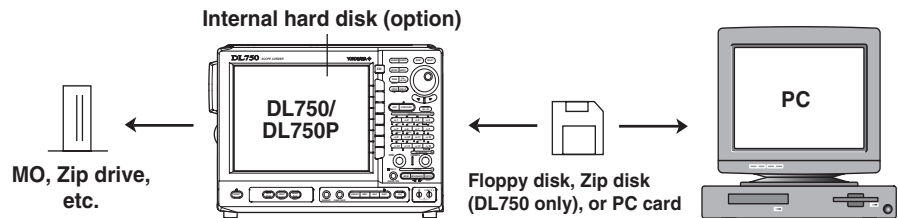

### Saving the Screen Image Data and Displaying the Thumbnails of the Stored Screen Image Data

The screen image data can be stored to a specified storage medium. As necessary, a voice comment can be saved along with the data. The data can be stored in PNG, JPEG, BMP, and PostScript formats allowing the data to be pasted on a document created with a DTP application.

In addition, the thumbnails (reduced and simplified image) of the screen image data saved to the storage medium can be displayed on the DL750/DL750P screen. This feature is useful for checking the contents of the stored screen image data.

#### • Thumbnail Display on the FILE Menu

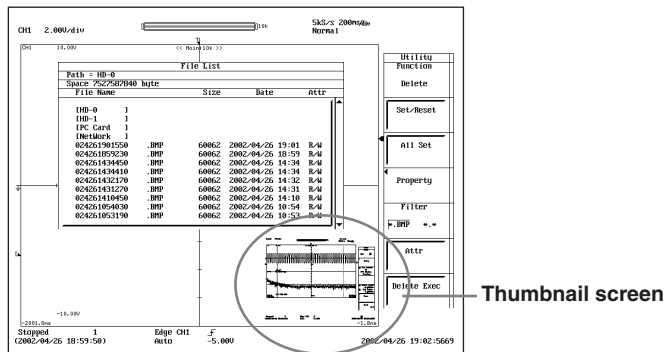

Selecting a file from the File List and pressing SELECT displays the thumbnail screen of the selected screen image data

#### • Thumbnail Display on the IMAGE SAVE Menu

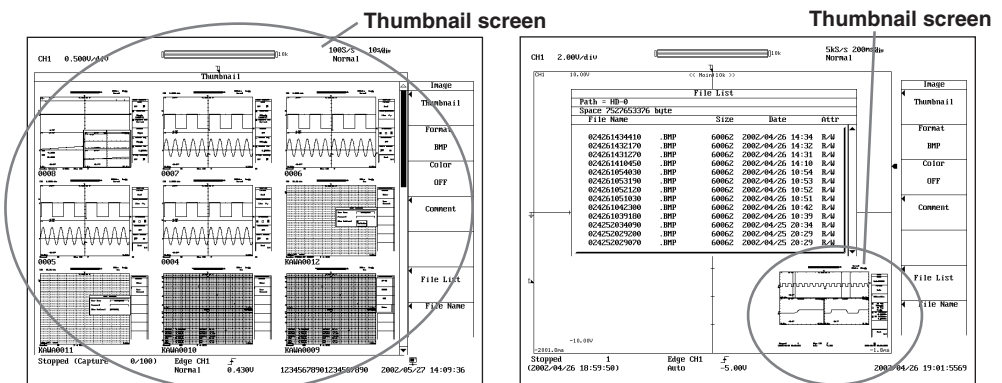

Pressing the Thumbnail soft key displays a thumbnail screen of the screen image data saved to the specified format.

Selecting a file from the File List and pressing SELECT displays the thumbnail screen of the selected screen image data

**Saving and Loading Setup Data, Waveform Data, and Snapshot Waveform Data**

The setup data, waveform data, and snapshot waveform data can be saved to or loaded from a specified storage medium.

When a waveform that has a voice memo recorded is saved, the voice memo is saved along with the waveform data.

**Saving the Results of the Automated Measurement of Waveform Parameters**

The results of the automated measurement of waveform parameters can be saved to a specified storage medium.

**Creating a PDF File of the Print Image (DL750P Only) <Section 13.13>**

By setting the output destination in the DL750P PRINT menu to “PDF,” a PDF file of the print image (image similar to fine print (see section 12.2)) can be created. A print image of the specified range and magnification is created to the specified file name on the specified storage medium simply by pressing the PRINT key.

**Voice Comment Function <Sections 3.14 and 13.19>**

A voice comment can be attached to screen image data to be saved. The maximum length of voice comment that can be attached to a single screen image data is 10 s. The saved voice comment can be played from the File List window<sup>1</sup> of the IMAGE and FILE menus.

The voice comment function can perform the following operations.

Record: There are two record methods.

- Record a voice comment before saving the screen image data by pressing the PUSH switch on the earphone microphone connected to the DL750/DL750P.
- Record a voice comment by pressing a button on the dialog box that appears when the screen image data is saved.

Save: Saves the voice comment along with the screen image data.

Play: When screen image data with a voice comment is selected on the File List window<sup>1</sup> of the IMAGE or FILE menu, the voice comment is played along with the thumbnail display.

1. For a description of the File List window, see section 13.12, “Displaying Thumbnails of the Saved Screen Image Data.”

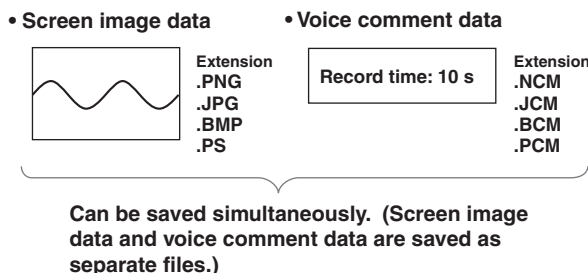

**Note**

A voice recorded when waveform acquisition is stopped becomes a voice comment.

### Operating the instrument Using a Free Software Program

The instrument can be controlled from a PC using Wirepuller, a free software program, when connected via the GP-IB, USB, or Ethernet interface. The software program can be downloaded from the following Web pages.

- English version      <http://www.yokogawa.com/tm/tm-softdownload.htm>
- Japanese version    <http://www.yokogawa.co.jp/tm/F-SOFT/>

### Connecting the DL750/DL750P and the PC via the SCSI <Section 13.18>

You can connect a PC to the SCSI of the DL750/DL750P and download the files on the internal hard disk (optional) to the PC.

You cannot upload or delete files on the internal hard disk. If you do, the internal hard disk may become unusable.

In addition, the following limitations exist.

While connected to the PC, the File List window of the DL750/DL750P may not be displayed properly. If the connected PC enters sleep, standby, or rest mode, the DL750/DL750P will not be able to access the internal hard disk. Before connecting the PC to the DL750/DL750P, disable such modes on the PC.

## 3.1 Handling Precautions

### Safety Precautions

If you are using this instrument for the first time, make sure to thoroughly read the “Safety Precautions” given on page Part 1:viii to Part 1:x.

#### **Do not Remove the Case**

Do not remove the case from the instrument. Some parts of the instrument use high voltages, which are extremely dangerous. For internal inspection or adjustment, contact your nearest YOKOGAWA dealer.

#### **In Case of Irregularity**

If you notice smoke or unusual odors coming from the instrument, immediately turn OFF the power and unplug the power cord. If such an irregularity occurs, contact your dealer or the nearest YOKOGAWA representative.

#### **Power Cord**

Nothing should be placed on the power cord; also, it should be kept away from any heat sources. When unplugging the power cord from the outlet, never pull by the cord itself. Always hold and pull by the plug. If the power cord is damaged, contact your dealer for replacement. Refer to page Part 1:v for the part number when placing an order.

### General Handling Precautions

#### **Never Place Anything on Top of the Instrument**

Never place other instruments or objects containing water on top of the instrument, otherwise a breakdown may occur.

#### **Do not Cause Shock to the Input Section**

Shock to the input connectors or probes may turn into electrical noise and enter the instrument via the signal lines.

#### **Do not Damage the LCD**

Since the LCD screen is very vulnerable and can be easily scratched, do not allow any sharp objects near it. Also it should not be exposed to vibrations and shocks. When not using the instrument for a long period, unplug the power cord from the AC outlet.

#### **When the Instrument Is not going to Be Used for a Long Period**

Unplug the power cord from the AC outlet.



### 3.1 Handling Precautions

---

#### **When Moving the Instrument**

Remove the power cord and connecting cables. Always carry the instrument by the handles as shown below or carry it with both hands.

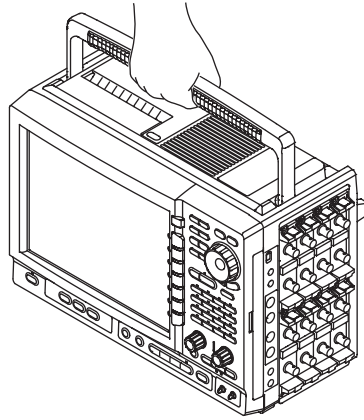

#### **Cleaning**

When cleaning the case or the operation panel, first remove the power cord from the AC outlet. Then, wipe with a dry, soft, clean cloth. Do not use volatile chemicals such as benzene or thinner for cleaning, as this may lead to discoloration or deformation.

## 3.2 Installing the Instrument

### Installation Conditions

Install the instrument in a place that meets the following conditions.

#### Flat, Even Surface

Set the instrument in the proper direction (see page 3-4) and in a level and stable place. Note that the instrument can be tilted on the stand if the instrument is set with the rear panel facing down. If placed in an uneven or unstable place, printing quality may deteriorate.

#### Well-Ventilated Location

Vent holes are situated on the bottom side of the instrument. In addition, vent holes for the cooling fans are also situated in the left side and the bottom. To prevent internal overheating, allow for enough space around the instrument (see the figure below) and do not block the vent and inlet holes.

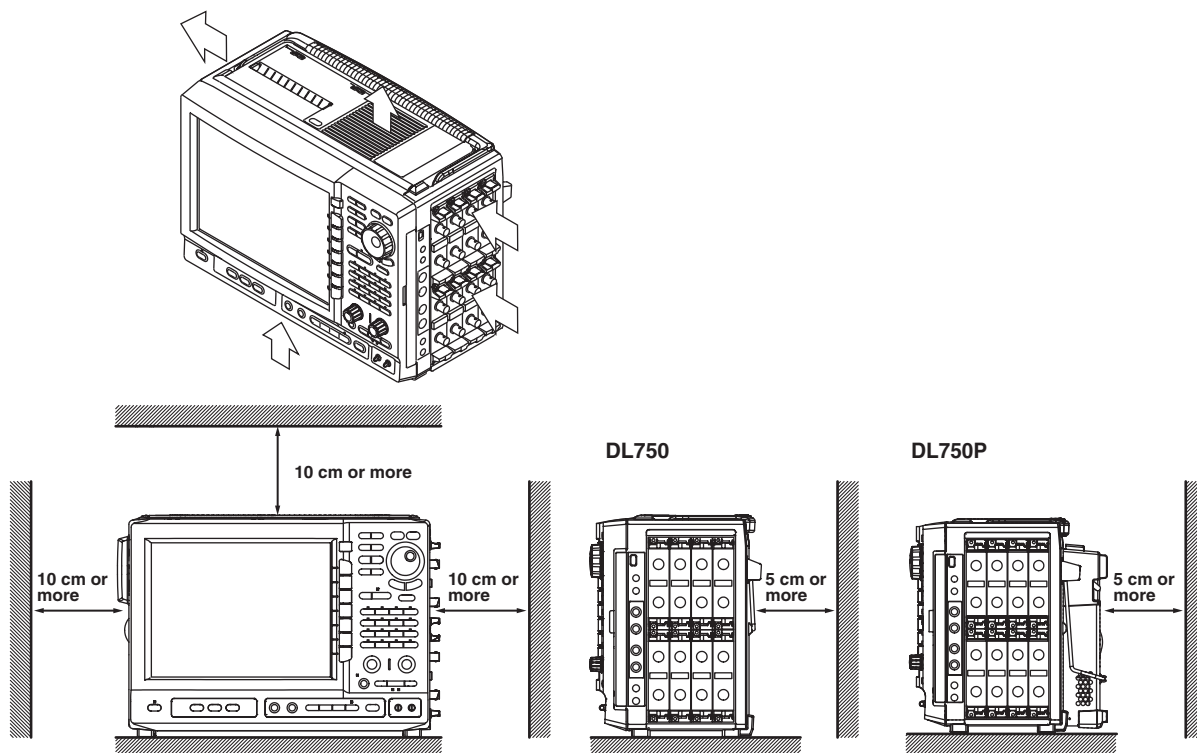

When connecting the various cables or when opening or closing the built-in printer cover, take extra space in addition to the space indicated above for the operation.

#### Ambient Temperature and Humidity

Ambient temperature: 5 to 40°C

Ambient humidity: 20 to 85% RH (when not using the printer) } No condensation  
35 to 85% RH (when using the printer)

#### Note

- To ensure high measurement accuracy, operate the instrument in the  $23 \pm 5^\circ\text{C}$  temperature range and  $55 \pm 10\%$  RH.
- Condensation may occur if the instrument is moved to another place where the ambient temperature is higher, or if the temperature changes rapidly. In such cases, allow the instrument adjust to the new environment for at least an hour before using the instrument.

#### Do Not Install the Instrument in the Following Places.

- In direct sunlight or near heat sources.
- Where an excessive amount of soot, steam, dust, or corrosive gas is present.
- Near strong magnetic field sources.
- Near high voltage equipment or power lines.
- Where the level of mechanical vibration is high.
- In an unstable place.

#### Installation Position

Place the instrument in a horizontal position or with the rear panel facing down. When using the stand, pull it until it locks (see the lower left figure). To retract it, press the stand backward while pressing it inward.

##### DL750

Installed horizontally

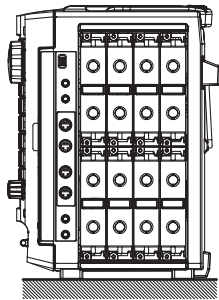

Installed with the rear panel facing down

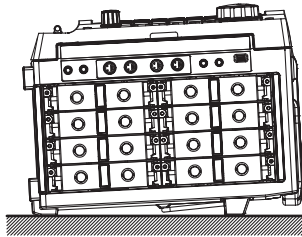

Installed using the stand

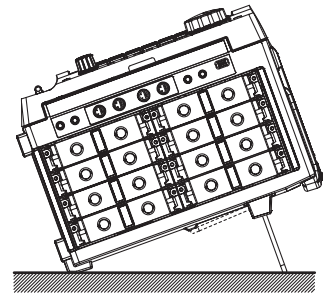

##### DL750P

Installed horizontally

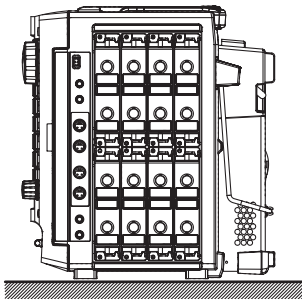

Installed with the rear panel facing down

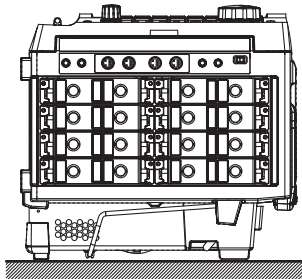

Installed using the stand

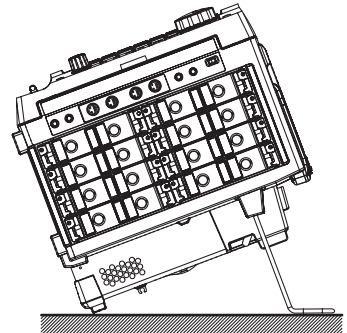

---

#### **CAUTION**

Do not use the Zip drive when the instrument is placed on the stand, as it may damage the data on the Zip disk.

---

#### Rubber Feet

If the instrument is installed in a horizontal position as shown in the figure above, rubber stoppers can be attached to the feet to prevent the instrument from sliding. One set (four pieces) of rubber feet are included in the package.

## 3.3 Installing Input Modules



### WARNING

- To prevent electric shock and damage to the instrument, make sure to turn OFF the power before installing or removing the input module.
- Check that the input cable is not connected to the input terminals before installing or removing the input module.
- To prevent electric shock and to satisfy the specifications, make sure to put the accessory cover plate on the slots that are not being used.

Using the instrument without the cover plate allows the dust to enter the instrument and may cause malfunction due to the rise in temperature inside the instrument.

- If the input module happens to come out of the slot while it is in use, it may cause electric shock or cause damage to the instrument as well as the input module. Make sure to screw the input module in place at the two locations (top and bottom).
- Do not put your hand inside the slot, because there are protrusions along the module guide that may injure your fingers.
- **In Using the Modules**
  - Do not apply input voltage exceeding the maximum input voltage, withstand voltage, or allowable surge voltage.
  - To prevent the possibility of electric shock, be sure to furnish protective earth grounding of the DL750/DL750P.
  - To prevent the possibility of electric shock, be sure to fasten the module screws. Otherwise, the electrical protection function and the mechanical protection function will not be activated.
  - Avoid continuous connection under an environment in which the allowable surge voltage may occur.
  - When using the 701250 (HS10M12) or the 701251 (HS1M16) to measure high voltage, use the isolated probe (700929), 1:1 safety cable (combination of 701901 and 701954), or the differential probe (700924).
  - Be sure to connect the GND lead of the differential probe (700924) to the functional ground terminal of the DL750/DL750P. High voltage may appear at the BNC connector of the differential probe. Be sure to connect the GND lead to the DL750/DL750P before connecting the probe to the parameter to be measured.
  - When using the 701255 (NONISO\_10M12), be sure to fasten the module screws. Fastening the module screws activates the protection function and the non-isolation function. It is extremely dangerous if you do not fasten the screws. In addition, when measuring high voltage above 42 V, be sure to use the Passive Probe for the DL750/DL750P (701940)
  - The BNC part of the Passive Probe for the DL750/DL750P (701940) is made of metal. Therefore, use the probe at 42 V or less for isolated inputs (701250 (HS10M12), 701251 (HS1M16), 701260 (HV (with RMS)), 701275 (ACCL/VOLT), 701280 (FREQ), etc.) for safety reasons. (Do not connect voltage above 42 V to both the High and Low sides.) For non-isolated inputs (701255 (NONISO\_10M12), etc.), fasten the module screws as described before.
  - When applying high voltage using the 701260 (HV (with RMS)), 1:1 safety cable (combination of 701901 and 701954) or the isolated probe (700929).
  - The measurement category of the 701260 (HV (with RMS)) is 400V-CATII on the low side and 700V-CATII on the high side. Use caution because the overvoltage tolerance differs between the low and high sides.
  - When applying high voltage to the 701280 (FREQ), use the isolated probe (700929).

#### Types of Input Modules

The following nine types are available.

- High-Speed 10 MS/s, 12-Bit Isolation Module: 701250 (HS10M12)
- High-Speed 10 MS/s, 12-Bit Non-Isolation Module: 701255 (NONISO\_10M12)
- High-Voltage 100 kS/s, 16-Bit Isolation Module (with RMS): 701260 (HV (with RMS))
- Universal (Voltage/Temp.) Module: 701261 (UNIVERSAL)
- Universal (Voltage/Temp.) Module (with AAF): 701262 (UNIVERSAL (AAF))
- Temperature, High Precision Voltage Isolation Module: 701265 (TEMP/HPV)
- Strain Module (NDIS): 701270 (STRAIN\_NDIS)
- Strain Module (DSUB, Shunt-Cal): 701271 (STRAIN\_DSUB)
- Acceleration/Voltage Module (with AAF): 701275 (ACCL/VOLT)
- Frequency Module: 701280 (FREQ)

#### Precautions to Be Taken When Installing or Removing Input Modules

- Switching the installed input module with a different module and turning ON the power initializes the settings on that channel. To save the settings, specify the destination media and save the values (see section 13.8, "Saving/Loading Setup Data").

#### Installation Procedure of Modules

1. Check that the power switch on the left side panel is OFF.
2. Check the channel number indicated above the slots for installing the input modules on the right side panel of the instrument. Then, install the module along the guide.  
Holding the handles on the top and bottom of the input module, press hard until it clicks in place.  
If there is a cover plate on the slot in which to install the module, remove the cover plate, first.
3. Make sure to screw the two locations, top and bottom, of the input module firmly into place (screw tightening torque: 0.6 N·m).
4. Turn ON the power switch.
5. Check to see that the correct input module name is displayed at the corresponding channel number in the overview screen. If it is not correct, remove the module according to the steps in "Removal" shown below, and reinstall the module according to steps 1 to 3 shown above.  
For the procedure in displaying the overview screen, see to section 18.4, "Checking the System Conditions (Overview)."

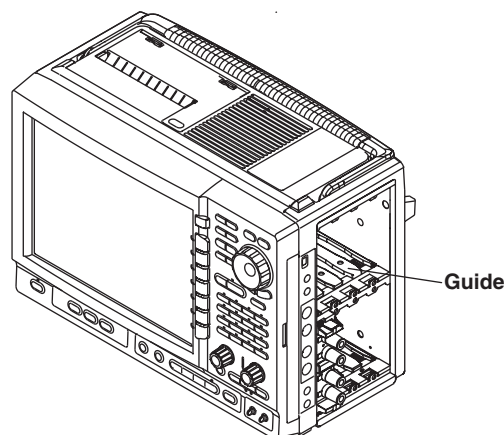

## Removal

1. Check that the power switch is OFF.
2. Loosen the screws holding the input module in place.
3. Holding the handles on the top and bottom of the input module, pull out the module.

## LEDs on the Frequency Module

On the front panel of the frequency module (701280 (FREQ)) are LEDs for each channel. These LEDs allow you to check the input condition of the pulse.

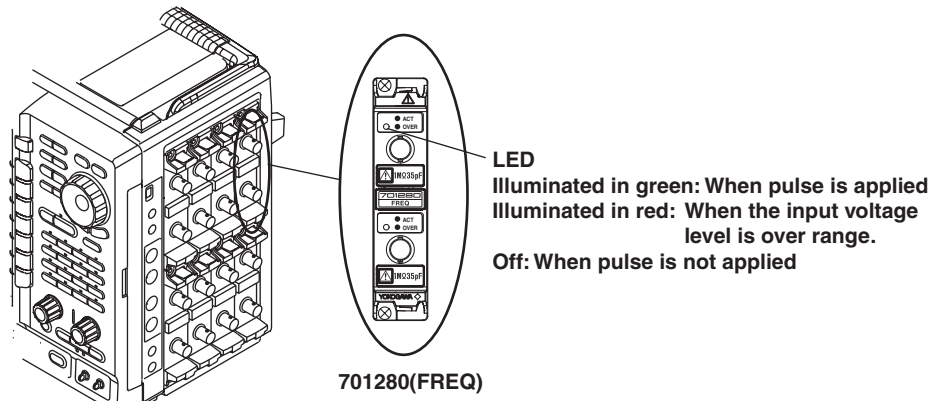

### Note

- The LEDs on the frequency module illuminates in green when pulse is applied and red when the input voltage level is over range. It is independent of the start/stop condition of waveform acquisition of the DL750/DL750P.
- If the frequency module preset (see section 5.19) is set to "EM Pickup (electromagnetic pickup)," the LED does not illuminate in red even when the input voltage level is over range.

## 3.4 Connecting the Power Supply and Turning the Power Switch ON/OFF

### Before Connecting the Power

Make sure that you observe the following points before connecting the power. Failure to do so may cause electric shock or damage to the instrument.



### WARNING

- Before connecting the power cord, ensure that the source voltage matches the rated supply voltage of the instrument and that it is within the maximum rated voltage of the provided power cord.
- Connect the power cord after checking that the power switch of the instrument is turned OFF.
- To prevent the possibility of electric shock or fire, be sure to use the power cord for the instrument that was supplied by YOKOGAWA.
- Make sure to perform protective earth grounding to prevent the possibility of electric shock. Connect the power cord to a three-pin power outlet with a protective earth terminal.
- Do not use an extension cord without protective earth ground. Otherwise, the protection function will be compromised.
- If an AC outlet that matches the power cord provided is unavailable and protective grounding cannot be furnished, do not use the instrument.

### Connecting the Power Cord

1. Check that the power switch is turned OFF.
2. Connect the power cord plug to the power connector on the left side panel.
3. Connect the plug on the other end of the power cord to the outlet that meets the conditions below. The AC outlet must be of a 3-prong type with a protective earth ground terminal.

#### Item

Rated supply voltage <sup>1</sup>	100 to 120 VAC/200 to 240 VAC
Permitted supply voltage range	90 to 132 VAC/180 to 264 VAC
Rated supply voltage frequency	50/60 Hz
Permitted supply voltage frequency range	48 to 63 Hz
Maximum power consumption	Approx. 200 VA (Reference value: 135 VA when the built-in printer is not used and 16 channels are running)

1. The DL750/DL750P can use a 100-V or a 200-V system for the power supply. The maximum rated voltage of the power cord varies depending on its type. Check that the voltage supplied to the DL750/DL750P is less than or equal to the maximum rated voltage of the provided power cord (see page Part 1:iv) before using it.

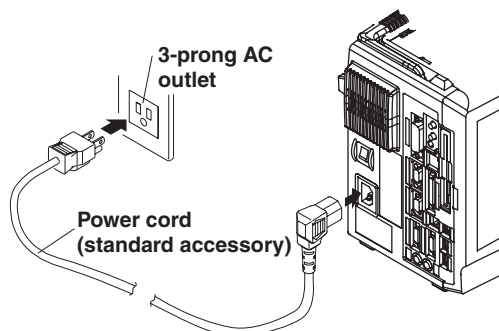

## Connecting the DC Power Supply to the DC Power Supply Model (/DC)

### WARNING

- Connect the DC power cord after checking that the power switch of the instrument is turned OFF. If you connect the power cord with the power switch turned ON, sparks may be emitted and can lead to fire.
- To prevent the possibility of electric shock or fire, be sure to use a power cord and power connector that YOKOGAWA specifies.
- Make sure to perform protective earth grounding to prevent electric shock.

### CAUTION

- There is a polarity to the DC power connector. Check the polarity when making a connection. If you have trouble connecting it, do not force it; check the connector direction.
- To prevent shorting the power supply, remove the power cord from the power supply when the power supply is not in use.

### Creating the Power Cord

Create a power cord using the power connector that comes with the package. For the power cord, use a cable that is between AWG12 (conductive cross-sectional area of 3.3 mm<sup>2</sup>) and AWG14 (conductive cross-sectional area of 2.1 mm<sup>2</sup>) with an outer diameter less than or equal to 3.6 mm.

There are two types of terminal tips. Use the tip with a small diameter for the protective grounding terminal.

1. Remove the two screws from the DC power connector.
2. Press the latch pawl in the direction of the arrow as shown and remove the connector case. Take out the cable cover that is stored in the connector.

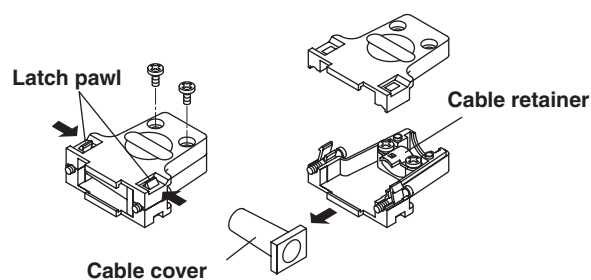

3. Remove the two cable retainer screws.
4. Run the cable through the cable cover.
5. Solder the power cable to the three terminal tips provided. Solder the protective grounding cable to the tip with the small diameter.

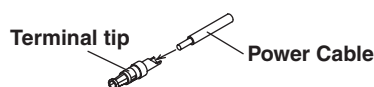



### 3.4 Connecting the Power Supply

- Insert the terminal tips into the terminal block as shown in the figure. The connector numbers and power polarities are listed below.

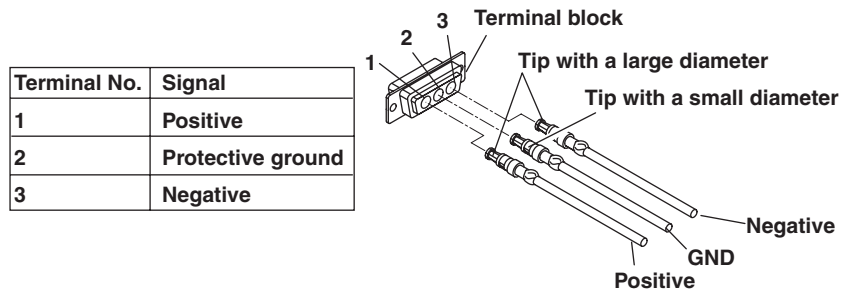

- Replace the attachment screws as necessary. You can remove the attachment screws by pulling the screws in the direction of the arrow.
- Attach the cable<sup>25</sup> to the connector. Set the chip mount flange and cable cover flange in the connector case grooves. Secure the cable in place using the cable retainer.

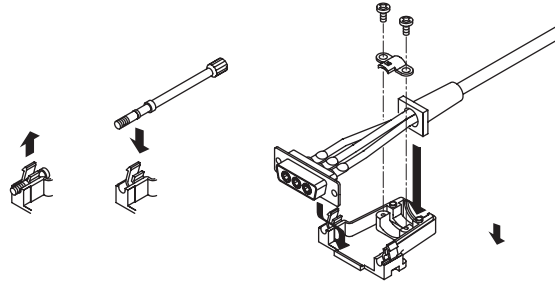

- Put the connector case on and fasten it with screws.

#### Connecting to the Power Supply

Connect the power cord as shown in the figure below. The power supply must meet the following conditions:

Item	
Rated supply voltage	12 VDC
Permitted supply voltage range	10 to 18 VDC (at the DL750/DL750P connector end)
Maximum power consumption	Approx. 120 VA Max. (Reference value: 80 VA when the built-in printer is not used and 16 channels are running)

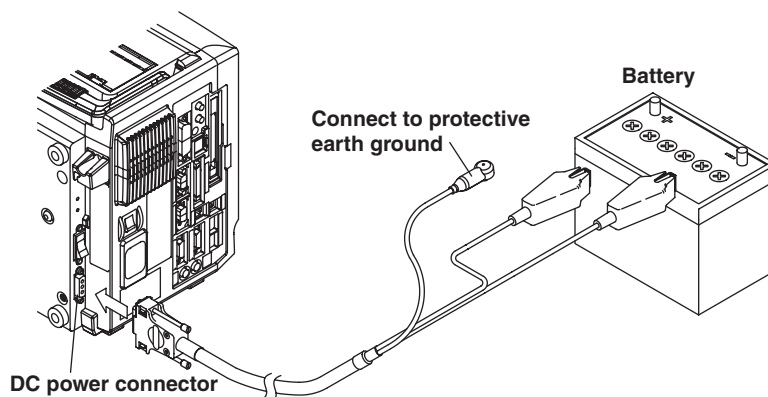

#### Note

- If both AC power and DC power are supplied, AC power takes precedence.
- If both AC power and DC power are supplied and AC power is cut off, the power instantaneously switches to DC power.

## Turning ON/OFF the Power Switch

### Items to Be Checked before Turning ON the Power

- The instrument is properly installed.: See section 3.2, "Installing the Instrument."
- The power cord is properly connected.: See section 3.4, "Connecting the Power Supply."

### Turning ON/OFF the Power Switch

Pressing the power switch located on the left side panel to the "ON(I)" side, turns the power ON. Pressing it to the "OFF(O)" side turns the power OFF.

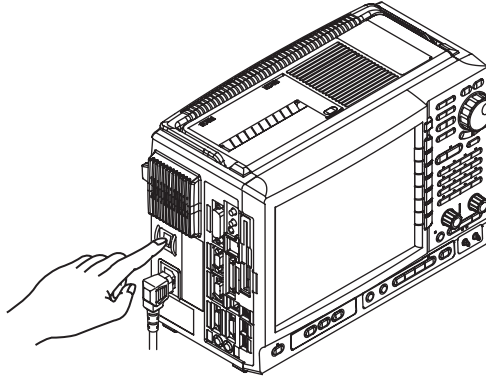

## Turning ON/OFF the DC Power (/DC)

### Items to Be Checked before Turning ON the Power

- The instrument is properly installed.: See section 3.2, "Installing the Instrument."
- The power cord is properly connected.: See section 3.4, "Connecting the Power Supply."

### Turning ON/OFF the Power Switch

Pressing the power switch located on the left side panel to the "ON(I)" side, turns the power ON. Pressing it to the "OFF(O)" side turns the power OFF.

### Note

If AC power is supplied and the main power switch to the AC power is ON, AC power is used.

### Status Display of the DC Power Supply

The power supply status is indicated on the LED on the left side panel.

#### AC LED

LED Status	Description
Illuminated in green	Operating on AC power

#### DC LED

LED Status	Description
Illuminated in green	Operating on DC power (AC power is not connected) Operating on AC power, and the DC supply voltage is within the operating range (10 to 18 VDC)
Illuminated in red	Operating on DC power, and the DC supply voltage is outside the operating range
Illuminated in orange	DC power is turning ON/OFF repeatedly (internal protection circuit is tripping) Power is not supplied in this condition. This status is automatically cleared after 10 to 20 seconds.
Illuminated in red	Internal circuit operation failure. Repair is necessary.
Off	Operating on AC power, and the DC supply voltage is within the operating range (10 to 18 VDC) or the DC power is not supplied

### Power Up Operation

Self-test and calibration start automatically when the power switch is turned ON. The operation takes approximately 30 seconds; if the check results are satisfactory, the normal waveform display screen will appear.

---

**Note**

- Allow at least 10 s when turning ON the power switch after turning it OFF.
  - If self-test and calibration do not start when the power is turned ON, or if the normal waveform display screen does not appear, turn OFF the power switch and check the following points.
    - Check that the power cord is plugged in properly.
    - Check that the correct voltage is being supplied from the AC outlet. (See the previous page.)
    - If the power switch is turned ON while the RESET key is pressed, all settings will be reset to the factory settings. For details, See section 4.4, "Initializing Settings."
- If the instrument still fails to power up when the power switch is turned ON after checking these points, contact your nearest YOKOGAWA dealer.
- If you repeat the operation of turning the power switch ON and OFF on the optional DC power supply model, the DL750/DL750P will stop supplying power due to the tripping of the internal protection function. If you stop the operation of turning the power switch ON and OFF for 10 to 20 seconds, the internal protection function is cleared, and the DL750/DL750P starts supplying power again. The DC power supply LED illuminates in orange while power is not being supplied.
  - It may take a few seconds for the startup screen to appear.
- 

### For Accurate Measurements

- Allow the instrument to warm up for at least 30 minutes after turning ON the power switch.
- After warm-up is complete, perform calibration (see section 4.6). If the auto calibration is turned ON, the calibration is automatically executed when the T/div setting is changed or when the waveform acquisition is started.

### Power Down Operation

Settings made prior to turning OFF the power are retained (even if the power cord is removed). This allows display of waveforms using those saved settings the next time the power is turned ON.

---

**Note**

The settings are stored using an internal lithium battery. The battery lasts for approximately 5 years if it is used at an ambient temperature of 23°C. When the lithium battery voltage falls below a specified level, a message is displayed on the screen (error 907) when the power switch is turned ON. If this message appears frequently, the battery must be replaced quickly. The user cannot replace the battery. For battery replacement, contact your nearest YOKOGAWA dealer.

---

## 3.5 Setting the Date and Time

### Procedure

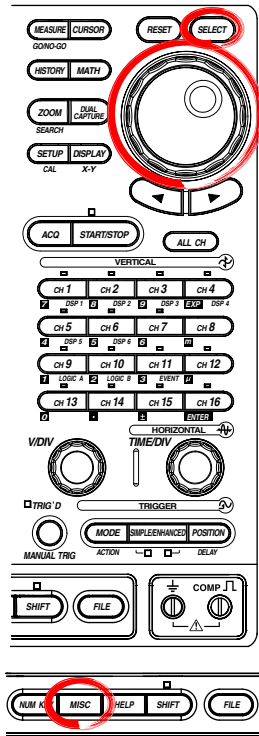

1. Press **MISC**.
2. Press the **System Config** soft key.
3. Press the **Date/Time** soft key. The date/time setting dialog box appears.

### Turning ON/OFF the Date/Time Display

4. Use the **jog shuttle** and **SELECT** to set the **Display ON** or **OFF**.

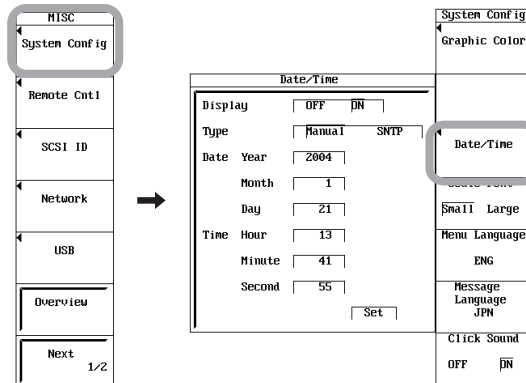

### Setting the Time and Date Manually (Manual)

5. Use the **jog shuttle** and **SELECT** to set the Type to Manual.
6. Use the **jog shuttle** and **SELECT** to set the Date Year.
7. Likewise, set the Month, Day, Time Hour, Minute, and Second.
8. Use the **jog shuttle** to move the cursor to Set and press **SELECT**. The date/time specified in steps 4 and 5 are applied.

### Setting the Date and Time Using the SNTP Server (Optional)

To obtain the time from the SNTP server, you must first connect to the network, and then to the SNTP server. For details, see section 16.2, "Setting up the TCP/IP," and section 16.8, "Setting the Time Difference from GMT (Greenwich Mean Time)/Setting SNTP."

9. Proceed to step 4, then use the **jog shuttle** and **SELECT** to set the Type to SNTP.

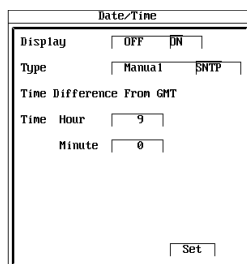

10. Use the **jog shuttle** and **SELECT** to set the time difference from GMT (Greenwich mean time).
11. Likewise, set the Minute.
12. Use the **jog shuttle** Set to move the cursor to Set.
13. Press **SELECT** to obtain the time from the SNTP server. The time and date calculated from the entered GMT time difference is set.

### 3.5 Setting the Date and Time

---

#### ***Explanation***

##### **Date (Year/Month/Date)**

Set the year, month and day.

##### **Time (Hour/Minute/Second)**

Set the time using a 24-hour clock.

##### **Setting the Time Using the SNTP Server**

You can use the SNTP server time to set the date and time on the instrument.

This function is available on models with the Ethernet interface installed.

For information on SNTP and GMS, see section 16.8, "Setting the Time Difference from GMT (Greenwich Mean Time)/Setting SNTP."

The difference from GMT set here is linked to the setting in section 16.8, "Setting the Time Difference from GMT (Greenwich Mean Time)/ Setting SNTP."

##### ***Note***

---

- The date and time information is backed up with the internal lithium battery even if the power is turned OFF.
  - Leap year information is also retained.
  - If you are using the Web server function (when the Ethernet interface option is installed), you must set the time offset from GMT (Greenwich Mean Time) in addition to the date and time. For the setup procedure, see section 16.8.
-

## 3.6 Connecting Probes

### Connecting Probes

Connect the probes (or other input cables such as BNC cables) to any of the input terminals of the following modules. The input impedance is  $1\text{ M}\Omega \pm 1\%$  and approximately 35 pF.

- High-Speed 10 MS/s, 12-Bit Isolation Module: 701250 (HS10M12)
- High-Speed High-Resolution 1 MS/s, 16-Bit Isolation Module: 701251 (HS1M16)
- High-Speed 10 MS/s, 12-Bit Non-Isolation Module: 701255 (NONISO\_10M12)
- High-Voltage 100 kS/s, 16-Bit Isolation Module (with RMS): 701260 (HV (with RMS))
- Acceleration/Voltage Module (with AAF): 701275 (ACCL/VOLT)
- Frequency Module: 701280 (FREQ)

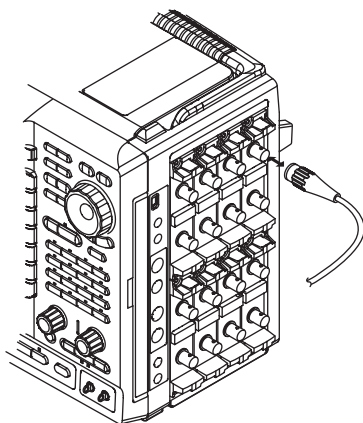

### WARNING

- When connecting the item to be measured, be sure to turn OFF the power to the item. Connecting or disconnecting the measuring lead while the item being measured is turned ON is very dangerous.
- **In Using the Modules**
  - Do not apply input voltage exceeding the maximum input voltage, withstand voltage, or allowable surge voltage.
  - To prevent the possibility of electric shock, be sure to furnish protective earth grounding of the DL750/DL750P.
  - To prevent the possibility of electric shock, be sure to fasten the module screws. Otherwise, the electrical protection function and the mechanical protection function will not be activated.
  - Avoid continuous connection under an environment in which the allowable surge voltage may occur.
  - Use only specified cables. Using cables that do not meet the safety specifications is extremely dangerous (especially when using high voltages (42 V or higher)).
  - When using the 701250 (HS10M12) or the 701251 (HS1M16) to measure high voltage, use the isolated probe (700929), 1:1 safety cable (combination of 701901 and 701954), or the differential probe (700924).
  - When applying high voltage using the 701260 (HV (with RMS)), 1:1 safety cable (combination of 701901 and 701954) or the isolated probe (700929).

- The BNC part of the Passive Probe for the DL750/DL750P (701940) is made of metal. Therefore, use the probe at 42 V or less for isolated inputs (701250 (HS10M12), 701251 (HS1M16), 701260 (HV (with RMS)), 701275 (ACCL/VOLT), 701280 (FREQ), etc.) for safety reasons. (Do not connect voltage above 42 V to both the High and Low sides.) For non-isolated inputs (701255 (NONISO\_10M12), etc.), fasten the module screws.
- The measurement category of the 701260 (HV (with RMS)) is 400V-CATII on the low side and 700V-CATII on the high side. Use caution because the overvoltage tolerance differs between the low and high sides.
- When applying high voltage to the 701280 (FREQ), use the isolated probe (700929).
- **In Using the High Voltage Differential Probes**

Be sure to connect the GND lead of the differential probe (700924/700925) to the functional ground terminal on the right side panel of the DL750/DL750P. Otherwise, high voltage may appear at the BNC connector making it dangerous.
- Applying a voltage exceeding the value indicated below may damage the input section. If the frequency is above 1 kHz, damage may occur even when the voltage is below this value.
- **High-Speed 10 MS/s, 12-Bit Isolation Module (701250)**

**Maximum input voltage (at a frequency of 1 kHz or less)**

  - Combined with the isolated probe 700929 (10:1)<sup>1</sup>  
600 V (DC+ACpeak)
  - Safety cable (1:1) (combined with 701901+701954)<sup>5</sup> or direct input<sup>9</sup>  
250 V (DC+ACpeak)

**Maximum allowable common mode voltage (at a frequency of 1 kHz or less)**

  - Combined with the isolated probe 700929 (10:1)<sup>2</sup> or safety cable (1:1) (combined with 701901+701954)<sup>8</sup>  
400 Vrms (CAT I), 300 Vrms (CAT II)
  - Direct input<sup>10</sup>  
42 V (DC+ACpeak) (CAT I and CAT II, 30 Vrms)
- **High-Speed High-Resolution 1 MS/s, 16-Bit Isolation Module (701251)**

**Maximum input voltage (at a frequency of 1 kHz or less)**

  - Combined with the isolated probe 700929 (10:1)<sup>1</sup>  
600 V (DC+ACpeak)
  - Safety cable (1:1) (combined with 701901+701954)<sup>5</sup> or direct input<sup>9</sup>  
140 V (DC+ACpeak)

**Maximum allowable common mode voltage (at a frequency of 1 kHz or less)**

  - Combined with the isolated probe 700929 (10:1)<sup>2</sup> or safety cable (1:1) (combined with 701901+701954)<sup>8</sup>  
400 Vrms (CAT I), 300 Vrms (CAT II)
  - Direct input<sup>10</sup>  
42 V (DC+ACpeak) (CAT I and CAT II, 30 Vrms)
- **High-Speed 10 MS/s, 12-Bit Non-Isolation Module (701255)**

This module is non-isolated. Be sure to fasten the module screws when measuring a voltage above 42 V on this module. In addition, use the dedicated non-isolated passive probe (10:1) (701940).

**Maximum input voltage (at a frequency of 1 kHz or less)**

  - Combined with the passive probe (701940) (10:1)  
600 V (DC+ACpeak)
  - Direct input<sup>9</sup>  
250 V (DC+ACpeak)

- **High-Voltage 100 kS/s, 16-Bit Isolation Module (with RMS) (701260)**

**Maximum input voltage (at a frequency of 1 kHz or less)**

- Combined with the isolated probe 700929 (10:1)<sup>1</sup>  
1000 V (DC+ACpeak)
- Safety cable (1:1) (combined with 701901+701954)<sup>5</sup> or direct input<sup>9</sup>  
850 V (DC+ACpeak)

**Maximum allowable common mode voltage (at a frequency of 1 kHz or less)**

- Combined with the isolated probe 700929 (10:1)  
1000 Vrms (CAT II) on the H side<sup>3</sup>, 400 Vrms (CAT II)<sup>4</sup> on the L side
- Safety cable (1:1) (combined with 701901+701954)  
700 Vrms (CAT II) on the H side<sup>6</sup>, 400 Vrms (CAT II) on the L side<sup>7</sup>
- Direct input<sup>10</sup>  
42 V (DC+ACpeak) (CAT I and CAT II, 30 Vrms)

- **701275 (ACCL/VOLT)**

**Maximum input voltage (at a frequency of 1 kHz or less)**

- Combined with the passive probe (701940) (10:1)<sup>11</sup> or direct input<sup>9</sup>  
42 V (DC+ACpeak)

**Maximum allowable common mode voltage (at a frequency of 1 kHz or less)**

- Combined with the passive probe (701940) (10:1)<sup>12</sup> or direct input<sup>10</sup>  
30 Vrms (CAT I and CAT II)

- **701280 (FREQ)**

**Maximum input voltage (at a frequency of 1 kHz or less)**

- Combined with the isolated probe 700929 (10:1)<sup>1</sup>  
420 V(DC+ACpeak)
- Safety cable (1:1) (combined with 701901+701954)<sup>5</sup> or direct input<sup>9</sup>  
42 V (DC+ACpeak)

**Maximum allowable common mode voltage (at a frequency of 1 kHz or less)**

- Combined with the isolated probe 700929 (10:1)<sup>2</sup>  
300 Vrms (CAT I and CAT II)
- Safety cable (1:1) (combined with 701901+701954)<sup>8</sup> or direct input<sup>10</sup>  
30 Vrms (CAT I and CAT II)

Combined with the 700929

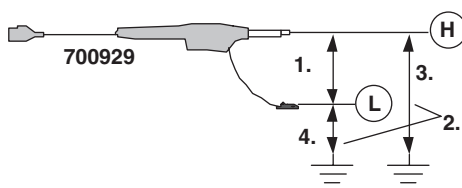

Combined with the 701901+701954

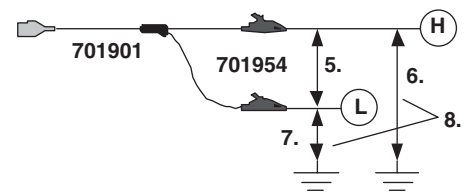

Direct input  
(cable not complying with the safety standard)

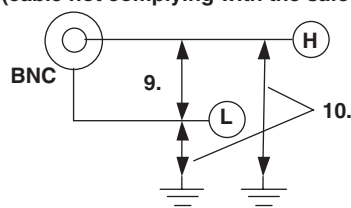

Combined with the 10:1 Passive Probe (701940)

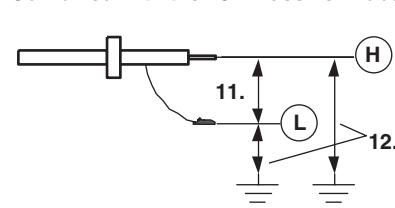



### Precautions to Be Taken When Connecting Probes

- When connecting a probe to the instrument for the first time, perform phase correction of the probe as described in section 3.7, “Compensating the Probe (Phase Correction).” Failure to do so will cause unstable gain across different frequencies, thereby preventing correct measurement. Make the phase correction on each channel to which the probe is to be connected.
- You cannot perform phase correction of the probe on the frequency module (701280(FREQ)). Perform phase correction of the probe on another module before connecting the probe to the 701280(FREQ).
- If the object to be measured is connected to the instrument directly, without using a probe, a correct measurement cannot be performed due to the input impedance.
- Precautions to Be Taken When Using Voltage Probes Other Than Isolated Probes (700929)
  - Correct measured values cannot be displayed if the probe’s attenuation is not 1:1, 10:1, 100:1, or 1000:1.
- Follow the instructions given in section 5.6, “Setting the Probe Type” to set the probe attenuation (type) to match the actual value using the soft key menu. If they do not match, measured values cannot be read correctly.

### Connecting Current Probes

When using current probes made by YOKOGAWA\*, use the probe power supply (optional) on the right side panel of the DL750/DL750P.

\* Current probes made by YOKOGAWA: 700937, 701930, 701931, and 701933

For details on the connection procedure, see the manual that came with the current probe.

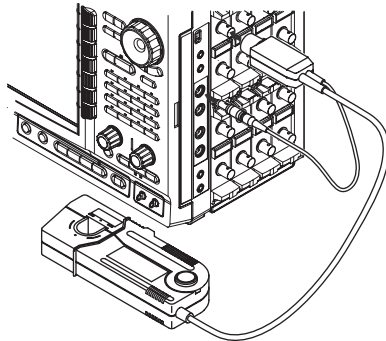

---

### **CAUTION**

Do not use the probe power supply terminals (optional) on the right side panel of the DL750/DL750P for purposes other than supplying power to the current probes. Also, be sure to use only the number of probes allowed. Otherwise, the DL750/DL750P or the devices connected to them may get damaged.

---

**Precautions to Be Taken When Using Current Probes**

When connecting the current probe to the probe power supply terminal on the right side panel, make sure that the current does not exceed the range shown below. Otherwise, the DL750/DL750P operation may become unstable due to the activation of the excessive current protection circuit of the power supply.

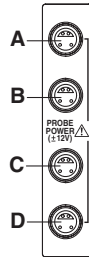

When each terminal is assigned names A through D  
(Total current consumption of A through D) ≤ 800 mA

**Specifications of the Probe Power Supply Terminals (Optional)**

Item	
Number of probes that can be used	4
Probes that can be used	Current probe (700937, 701930, 701931, and 701933)
Number of current probes that can be used	700937 (15 A): Up to 4 701930 (150 A): Up to 2 701931 (500 A): 1 701933 (30 A): Up to 2
Supply voltage	±12 V 2 outputs (up to a total of 800 mA)

When using the current probe, the number of probes that can be used is limited by the current generated by the device under measurement (current measured by the current probe). The characteristics of the measured current versus the current consumption of an active probe that can be connected to the DL750/DL750P are shown below.

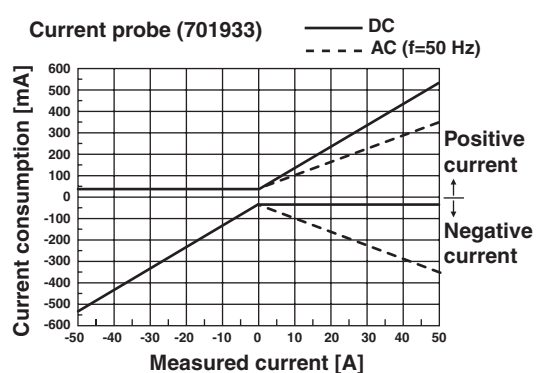
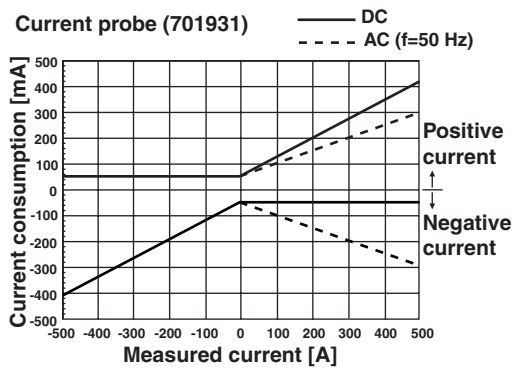
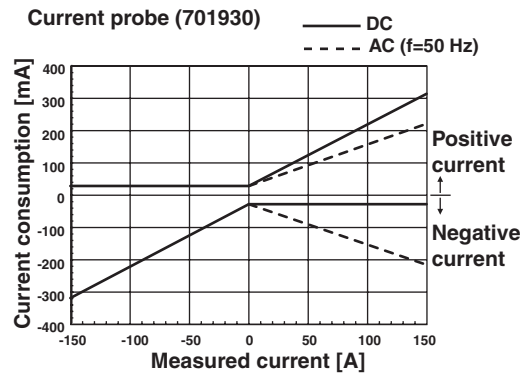
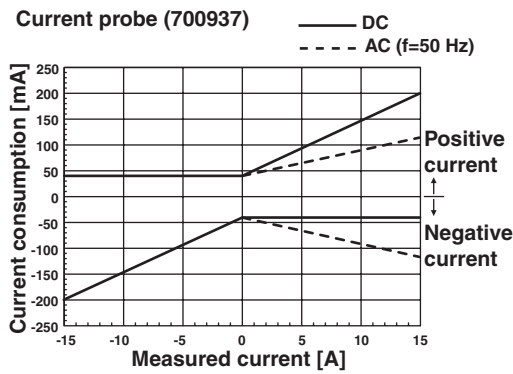

For details on the usage conditions of each probe, see "Relationship between the current being measured and probe's current consumption" on the following Web page.  
<http://www.yokogawa.com/tm/probe/>

#### Connecting Differential Probes (700924)

When using differential probes (700924) made by YOKOGAWA, connect the BNC output connector to the input terminal of the oscilloscope. In addition, be sure to connect the GND lead to the functional ground terminal of the DL750/DL750P. If necessary, use the auxiliary grounding lead extension. A measurement of 1400 V<sub>peak</sub> is possible by connecting the GND lead to the DL750/DL750P.

For details on the connection procedure, see the manual that came with the differential probe.

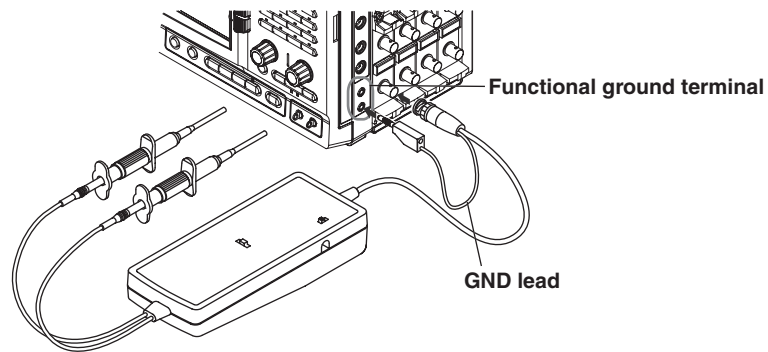

---

#### **WARNING**

##### **In Using the High Voltage Differential Probes**

Be sure to connect the GND lead of the differential probe (700924/700925) to the functional ground terminal on the right side of the DL750/DL750P.

Otherwise, high voltage may appear at the BNC connector making it dangerous.

Be sure to connect the GND lead to the DL750/DL750P before connecting the probe to the item to be measured.

---

## 3.7 Compensating the Probe (Phase Correction)

When making measurements using a probe on the following modules, be sure to perform phase correction of the probe first.

- High-Speed 10 MS/s, 12-Bit Isolation Module: 701250 (HS10M12)
- High-Speed High-Resolution 1 MS/s, 16-Bit Isolation Module: 701251 (HS1M16)
- High-Speed 10 MS/s, 12-Bit Non-Isolation Module: 701255 (NONISO\_10M12)
- High-Voltage 100 kS/s, 16-Bit Isolation Module (with RMS): 701260 (HV (with RMS))
- Acceleration/Voltage Module (with AAF): 701275 (ACCL/VOLT)
- Frequency Module: 701280 (FREQ)



### CAUTION

Never apply an external voltage to the probe compensation output terminal, as damage to the instrument may result.

### Procedure

1. Turn ON the power switch.
2. Connect the probe to the input terminal to which the signal is to be applied.
3. Connect the probe's tip to the probe compensation output terminal on the front panel and connect the earth wire to the functional earth terminal.
4. Perform auto setup according to the procedure described in section 4.5, "Performing Auto Setup."
5. Insert a flat-head screwdriver to the phase adjustment knob and turn the variable capacitor to make the displayed waveform a correct rectangular wave.

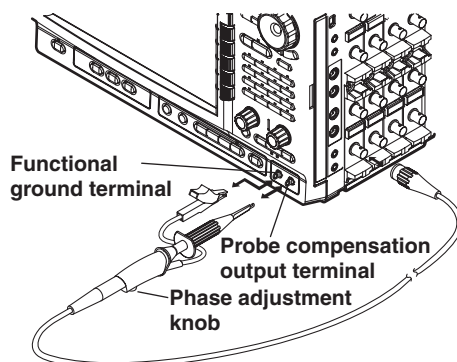

### Explanation

#### Necessity of Phase Correction of the Probe

If the input capacity of the probe is not within the adequate range, the gain across different frequencies will not be uniform. Consequently, waveforms cannot be displayed correctly. In addition, the input capacitance varies depending on the probe. Thus, the variable capacitor (trimmer) provided on the probe must be adjusted. This adjustment is called phase correction.

When using the probe for the first time, make sure to perform phase correction.

Furthermore, the appropriate input capacitance varies according to which channel is used, so probe compensation is required when the probe is switched from one channel to another.

### 3.7 Compensating the Probe (Phase Correction)

---

#### Compensation Signal

The COMP signal output terminal outputs the following rectangular wave signal.

Frequency: 1 kHz $\pm$ 1%

Amplitude: 1 V $\pm$ 10%

#### Differences in the Waveform Due to the Phase Correction of the Probe

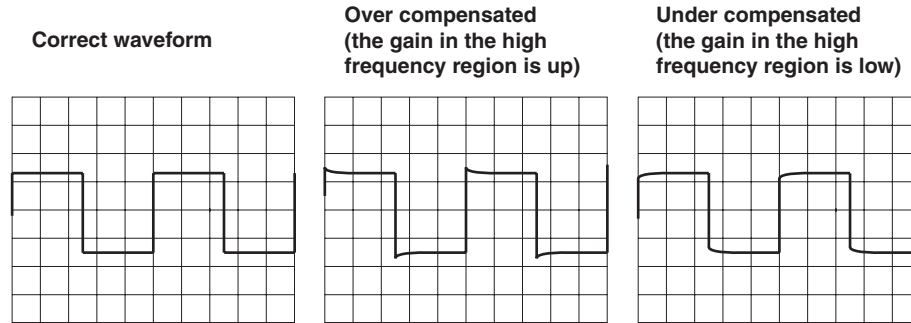

#### Precautions to Be Taken When Using the Probe on the Frequency Module

##### (701280 (FREQ))

You cannot perform phase correction of the probe on the frequency module. When connecting a probe to the frequency module, perform phase correction of the probe on another module beforehand.

## 3.8 Connecting Measuring Leads

### Connecting Measuring Leads

Connect measuring leads of bipolar banana plug terminal to the input terminal (binding post terminal) when measuring the voltage on the 701261 (UNIVERSAL), 701262 (UNIVERSAL (AAF)), or 701265 (TEMP/HPV) as shown below.

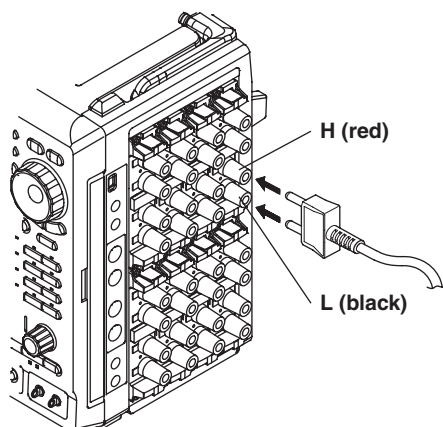

### WARNING

- When connecting the item to be measured, make sure to turn OFF the power to the item. Connecting or disconnecting the measuring lead while the item being measured is turned ON is very dangerous.
- To prevent electric shock, make sure to use the measuring lead suitable for the voltage range being measured on the input terminals of the 701261 (UNIVERSAL), 701262 (UNIVERSAL (AAF)), or 701265 (TEMP/HPV).
- Applying a voltage exceeding the value indicated below may damage the input section. If the frequency is above 1 kHz, damage may occur even when the voltage is below this value.

#### For 701261, 701262, or 701265

Maximum input voltage (across the input terminals, H and L<sup>1</sup>, at a frequency of 1 kHz or less)

42 V (DC+AC<sub>peak</sub>)

Maximum allowable common mode voltage (across the input terminals, H or L, and earth<sup>2</sup>, at a frequency of 1 kHz or less)

42 V (DC+AC<sub>peak</sub>) (CAT I and CAT II, 30 V<sub>rms</sub>)

- Do not connect a plug-in type terminal with exposed conducting parts to the input terminal to be used as a measuring lead. It is very dangerous, if the connector comes loose.

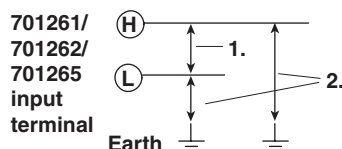

## 3.9 Connecting Thermocouples

### Connecting Thermocouples

If you are connecting the compensation lead of the thermocouple to the input terminal (binding post terminal) of the 701261 (UNIVERSAL), 701262 (UNIVERSAL (AAF)), or 701265 (TEMP/HPV), loosen the terminal knob, pass the lead through the terminal, and tighten the knob.

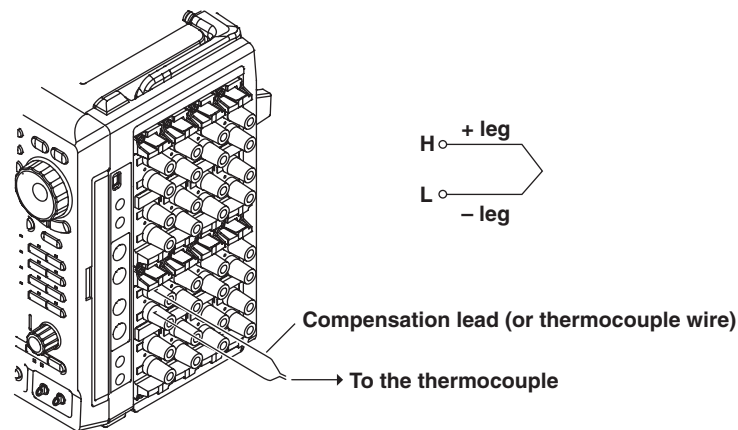

### CAUTION

- The 701261 (UNIVERSAL), 701262 (UNIVERSAL (AAF)), or 701265 (TEMP/HPV) is isolated from the DL750/DL750P. However, applying a voltage exceeding the value below may damage the input section. If the frequency is above 1 kHz, damage may occur even when the voltage is below this value.
  - Maximum input voltage (across the input terminals, H and L, at a frequency of 1 kHz or less)  
42 V (DC+ACpeak)
  - Maximum allowable common mode voltage (across the input terminal L and earth at a frequency of 1 kHz or less)  
42 V (DC+ACpeak) (CAT I and CAT II, 30 Vrms)
- Correct measurements cannot be made if the positive and negative legs of the thermocouple are reversed.
- Immediately after connecting the thermocouple, the heat balance may be disturbed at the input terminal section and may cause measurement errors. Therefore, wait about ten minutes before making a measurement.
- In an environment where the air from the air conditioning is directly applied to the input terminals or where there are effects from a heat source, the heat balance may be disturbed at the input terminal section and cause measurement errors.

When making measurements in this type of environment, take preventive measures such as changing the position.

## 3.10 Connecting a Bridge Head (Only on Strain Modules)

Strain is measured by connecting a strain gauge bridge (bridge head) or a strain gauge transducer to the strain module.

This section will mainly describe the procedures and precautions related to the connection of the bridge head (Model 701955/701956/701957/701958). For the connection of other strain gauge bridges or strain gauge transducers, see the respective manuals.



### CAUTION

Only connect a strain gauge bridge (bridge head) or a strain gauge transducer to the strain module. Connecting other devices or applying a voltage that exceeds the values indicated below to the strain module may damage the input section.

- Maximum input voltage (between Input+ and Input–)  
10 V (DC+ACpeak)
- Maximum allowable common mode voltage (between each terminal and earth ground)  
42 V (DC+ACpeak) (CAT I and CAT II, 30 Vrms)

### Connecting the Strain Gauge

The bridge head (701955/701956/701957/701958) supports six types of connection methods: single-gauge method, single-gauge three-wire method, adjacent-side two-gauge method, opposite-side two-gauge method, opposite-side two-gauge three-wire method, and four-gauge method. For details, see the manual that came with the bridge head (701955/701956/701957/701958).

If you are using a strain gauge bridge or a strain gauge transducer other than the bridge head (701955/701956/701957/701958), see the respective manuals.

### Connecting the Strain Module and the Bridge Head

#### When Using the Strain Module (701270) and the Bridge Head (701955/701956)

Using the cable that came with the bridge head (701955/701956), connect the Strain Module (701270) and the bridge head.

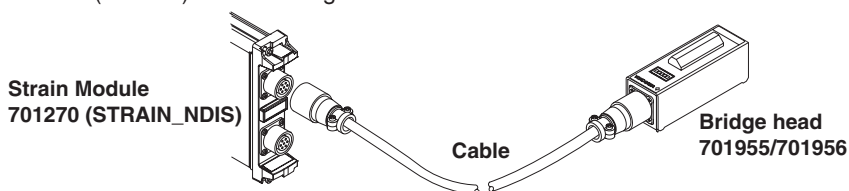

#### When Using the Strain Module (701271) and the Bridge Head (701957/701958)

Using the cable that came with the bridge head (701957/701958), connect the Strain Module (701271) and the bridge head.

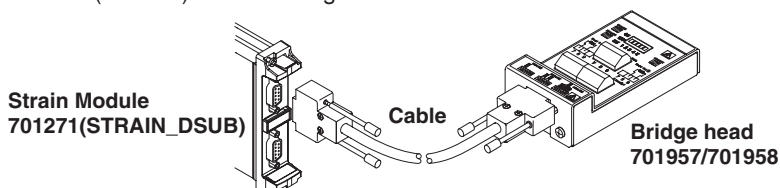



### 3.10 Connecting a Bridge Head (Only on Strain Modules)

#### When Using a Bridge Head with a MIL Standard (MIL-C-26482) Connector Wiring

The connector on the Strain Module (701270) is a NDIS connector<sup>1</sup>. Use a connector adapter cable (700935) by YOKOGAWA to make a MIL-NDIS conversion and connect to the Strain Module (701270).

1. A connector recommended by JSNDI (The Japanese Society for Non-destructive Inspection)

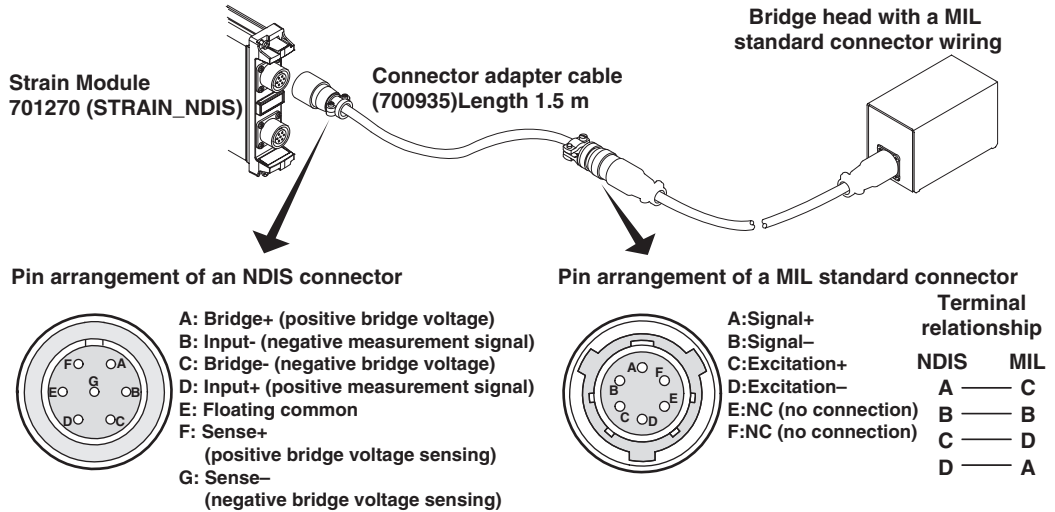

#### When Using the A1002JC Connector by YOKOGAWA

You can create your own cable by using the YOKOGAWA A1002JC connector that is compatible with the strain module and use the cable to connect a strain gauge bridge or a strain gauge transducer to the strain module.

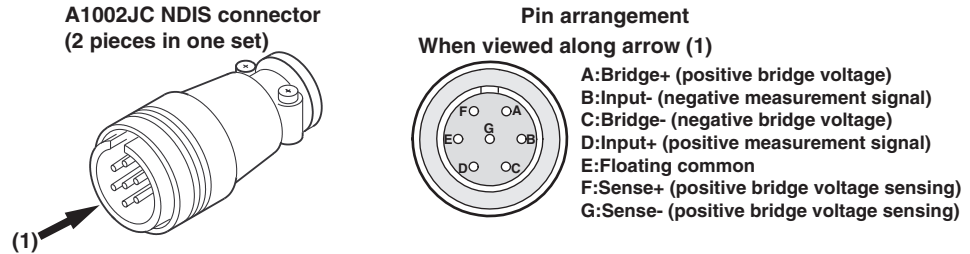

#### Note

- The connector shell is connected to the case potential (earth) of the DL750/DL750P.
- Signals A through G are isolated inside the module.
- When creating your own cable, we recommend that you use a shielded cable in order to shut out external noise.



### CAUTION

Take extra care when wiring the connectors. If the wiring is shorted or incorrect, it can damage the DL750/DL750P or other instruments that are connected to the DL750/DL750P.

**Pin Arrangement of the D-Sub Connector**

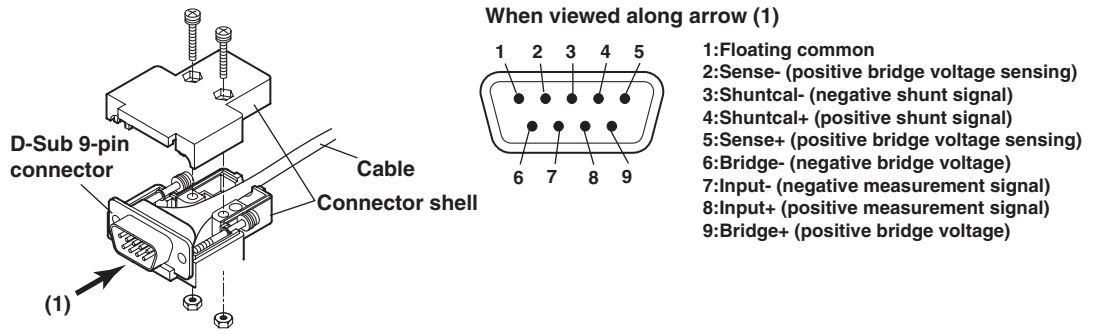

## 3.11 Connecting Logic Probes



### CAUTION

- Applying a voltage exceeding the value indicated below may damage the logic probe or the DL750/DL750P. If the frequency is above 1 kHz, damage may occur even when the voltage is below this value.
  - Maximum input voltage (at a frequency of 1 kHz or less)
    - High-Speed Logic Probe (700986): 42 V (DC+ACpeak)
    - Isolated Logic Probe (700987): 250 Vrms (except ACpeak is less than or equal to 350 V and DC is less than 250 V)
- On the high-speed logic probe, the 8 input lines on each POD have a common earth. In addition, the earth for the instrument and the earth for each POD are also common. Do not connect inputs which have different common voltages, as doing so may cause damage to the DL750/DL750P, logic probe, or other connected instruments.
- Each input terminal of the isolated logic probe is isolated from all other input terminals and the isolated logic probe is isolated from the DL750/DL750P.
- Make sure to turn off the instrument before connecting or disconnecting the 26-pin connector from the logic input connector.
- Do not stack the isolated logic probes during use. Also, allow enough space around the probes to avoid a temperature increase inside the probes.

### Logic Input Connector

Connect the logic probe (700986 or 700987) to either of the logic signal input connectors (marked LOGIC A and LOGIC B).

### About the Logic Probe

#### Types of Logic Probes

There are two types of probes available for connecting to the logic input connector of the DL750/DL750P.

- High-Speed Logic Probe (700986)
- Isolated Logic Probe (700987)

#### Types of Measuring Leads That Can Be Used

Use the following leads to connect to the point of measurement.

- **Types of Connecting Leads That Can Be Used on the High-Speed Logic Probe (700986)**

The following two types are available.

- Connecting lead (alligator clip, parts No. B9879PX)  
This lead is mainly used for connecting contact circuits. The lead consists of 8 signal lines (red) and 8 earth lines (black).
- Connecting lead (IC clip, parts No. B9879KX)  
This lead is mainly used for connecting electronic circuits. The lead consists of 8 signal lines (red) and 2 earth lines (black).

- **Types of Measuring Leads That Can Be Used on the Isolated Logic Probe (700987)**

Use the following measuring lead.

- For measuring voltages of 42 V or more: Measuring lead for isolation logic (758917)

An alligator adapter (758922), alligator adapter (758929), or alligator clip (dolphin type, 701954) is needed to make measurements.

**Note**

Do not alter the connecting leads. Doing so may cause the leads from satisfying the specification.

## Connecting Logic Probes

### High-Speed Logic Probe (700986)

1. Attach the accessory connecting lead (IC clip or alligator clip) to the logic probe, and lock the connector by clamping the lever inwards. To release the connecting lead from the logic probe, pull both levers outwards. Proceed to step 3.

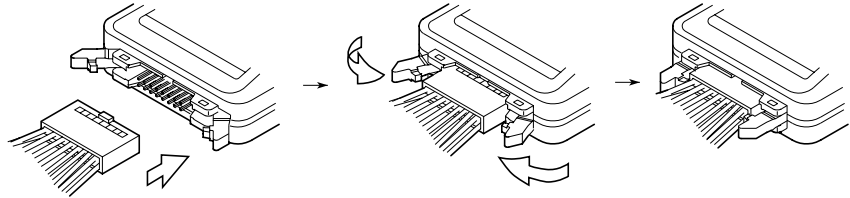

### Isolated Logic Probe (700987)

1. Connect the measuring lead to the input terminal of the logic probe.
2. Set the input switch. The threshold level is set to 50 VAC  $\pm$  50% (Hi: 80 to 250 VAC, Lo: 0 to 20 VAC) and 6 V  $\pm$  50% (Hi: 10 to 250 VDC, Lo: 0 to 3 VDC) when set to "AC" and "DC," respectively.

### Connecting the Logic Probe to the Logic Signal Input Connector

3. Turn OFF the DL750/DL750P.
4. Connect the end with the 26-pin connector (clamp filter with ferrite core, parts No. A1190MN) of the logic probe to the logic signal input connector of the DL750/DL750P.
5. Turn ON the DL750/DL750P.

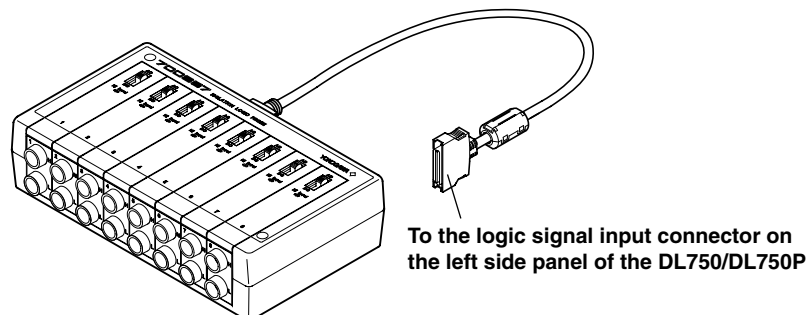

**Note**

- Each bit is displayed as "L level" when the logic probe is not connected to the instrument.
- For the specifications of the logic probe, see section 19.13, "Logic Probe Specifications."
- The logic input display is turned OFF by default. For the procedure in turning ON/OFF the display, see section 5.1, "Turning Channels ON/OFF."

## 3.12 Connecting Acceleration Sensors

An acceleration sensor is connected when measuring acceleration on the 701275 (ACCL/VOLT). For a details on acceleration sensors, see the respective manuals.



### CAUTION

- Applying a voltage that exceeds the values indicated below to the 701275 (ACCL/VOLT) may damage the input section.  
Maximum input voltage: 42 V (DC+ACpeak)
- When connecting acceleration sensors, do it without the bias current being supplied to the sensor. Otherwise, damage to the internal circuitry of the acceleration sensors may result.
- The DL750/DL750P only supports acceleration sensors that are driven by constant current with driving current of 4mA and driving voltage of 22 V.

### Connecting Acceleration Sensors

#### When Connecting Built-in Amplifier Type Acceleration Sensors

The DL750/DL750P allows built-in amplifier type (low impedance) acceleration sensors to be directly connected. To connect built-in amplifier type acceleration sensors, use BNC cables. Use cables that are appropriate for the acceleration sensors being used. Connect the acceleration sensors with the bias current turned OFF. After connection, turn ON the supply current to the acceleration sensors for making measurements.

#### When Connecting Charge Output Type Acceleration Sensors

Since the charge output type (high impedance) acceleration sensors do not have built-in amplifier circuit, they cannot be directly connected to the DL750/DL750P. Use either of the following two methods to connect the sensors.

- **Using the Charge Amplifier**

Connect the charge output type acceleration sensor to a charge amplifier using a highly isolated low-noise cable. The acceleration signal (charge signal) that has been converted to a voltage signal by the charge amplifier is input to the DL750/DL750P using a normal coaxial cable. The DL750/DL750P measures the signal in the voltage measurement mode. The measured data can be converted to acceleration values using the scale conversion function of the DL750/DL750P.

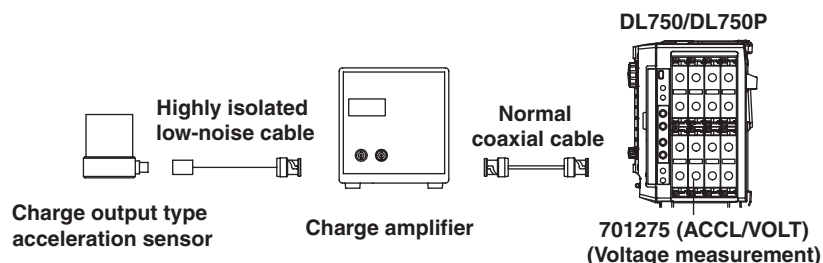

- **When using the charge converter**

Connect the charge output type acceleration sensor to a charge converter using a highly isolated low-noise cable. By driving the charge converter using a constant current from the DL750/DL750P, voltage signals similar to those of the built-in amplifier type acceleration sensor can be obtained. The DL750/DL750P measures the signals in the acceleration measurement mode and supplies bias current to the charge converter. Set the input sensitivity of the DL750/DL750P according to the charge converter gain and the sensitivity of the charge output type acceleration sensor.

The DL750/DL750P only supports charge converters that are driven by constant current with driving current of 4 mA and driving voltage of 22 V.

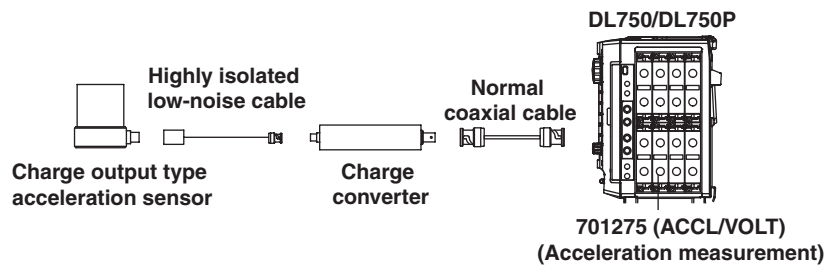

**Note**

The unit of measurement of acceleration on the DL750/DL750P is  $\text{m/s}^2$ . The sensitivity is sometimes expressed in units of  $\text{mV/G}$  depending on the acceleration sensor. In such case, convert the unit. ( $1 \text{ G} = 9.81 \text{ m/s}^2$ )

**Precautions**

- Do not apply shock outside the specifications (see the manual for the acceleration sensor) to the acceleration sensors. Doing so can damage the sensors.
- Do not impose drastic temperature changes on the acceleration sensors. Temperature changes may affect the output value of the acceleration sensors.
- By default, the bias current on the acceleration sensors is turned OFF. Be sure to turn it ON before using the acceleration sensors. Bias current is valid only when measuring acceleration. When measuring other parameters, it is automatically turned OFF. The ON/OFF setting of the bias current is retained even when you turn OFF the DL750/DL750P.

## 3.13 Connecting Sensors to the Frequency Module

### Sensors and Signal Output Sources That Can Be Connected

The table below shows the sensor and signal output source that can be connected. Appropriate input presets are provided for each sensor and signal output source. For the setup procedure of presets, see page 5-40.

Sensor and Signal Output Source	Preset Name
5-V logic signal, 5-V output sensor, and sensor with TTL output	Logic 5V
3-V logic signal and 3-V output sensor	Logic 3V
12-V driven relay/sequence circuit and 12-V driven sensor	Logic 12V
24-V driven relay/sequence circuit and 24-V driven sensor	Logic 24V
Sensor/Encoder that outputs positive and negative voltages and sensor that outputs sine waves	ZeroCross
100-VAC power supply (connected via the isolated probe (700929))	AC100V
200-VAC power supply (connected via the isolated probe (700929))	AC200V
Power-generating electromagnetic pickup	EM Pickup
Open collector output (0 to 5 V output) and contact output	Pull-up 5V*

\* For the internal equivalent circuit for "Pull-up 5V," see page 5-50.

### Precautions to Be Taken When Connecting to Sensors or Signal Output Sources



#### CAUTION

- The maximum input voltage for direct input is indicated below. Applying a voltage exceeding this value can damage the input section. If you are applying high voltage that exceeds 42 V, be sure to use the isolated probe (700929).  
Maximum input voltage: 42 V (DC+ACpeak) (CAT I and CAT II)
- The minimum input voltage is 0.2 Vpp. At voltage amplitude less than 0.2 Vpp, the measured values may be unstable.
- Attach/Remove the sensors after confirming that the rotating object to be measured is stopped.
- Set the preset to electromagnetic pickup (EM Pickup) only when using the electromagnetic pickup.

#### Connecting the Electromagnetic Pickup

- The DL750/DL750P allows power-generating electromagnetic pickup to be connected directly. The DL750/DL750P does not support electromagnetic pickups that require external power supply or those that require a terminator at the output.
- To connect electromagnetic pickups, use BNC cables. Use cables that are appropriate for the electromagnetic pickups being used.
- When the input is set to electromagnetic pickup, determination is not made on whether the input voltage level exceeds the specified input voltage range. Therefore, the LEDs (see page 3-7) do not illuminate even when the input voltage level is over range.

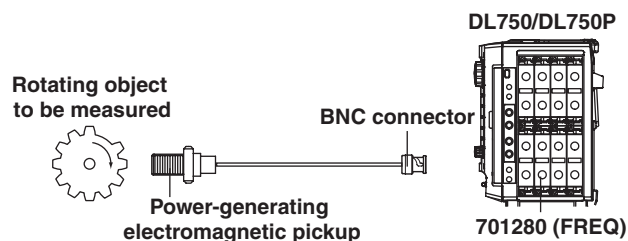

## 3.14 Connecting the Earphone Microphone with a PUSH Switch and Connecting the Speaker

The optional earphone microphone with a PUSH switch (701951) must be connected to use the voice memo function (see section 7.9) and voice comment function (section 13.19). The recorded voice memo and voice comment can be played through an external speaker by using an optional speaker cable (701952) that is sold separately.

### Connecting the Earphone Microphone with a PUSH Switch (701951)

Insert the  $\phi 2.5$  plug of the earphone microphone with a PUSH switch to the VOICE IN/OUT/SW terminal of the DL750/DL750P left side panel.

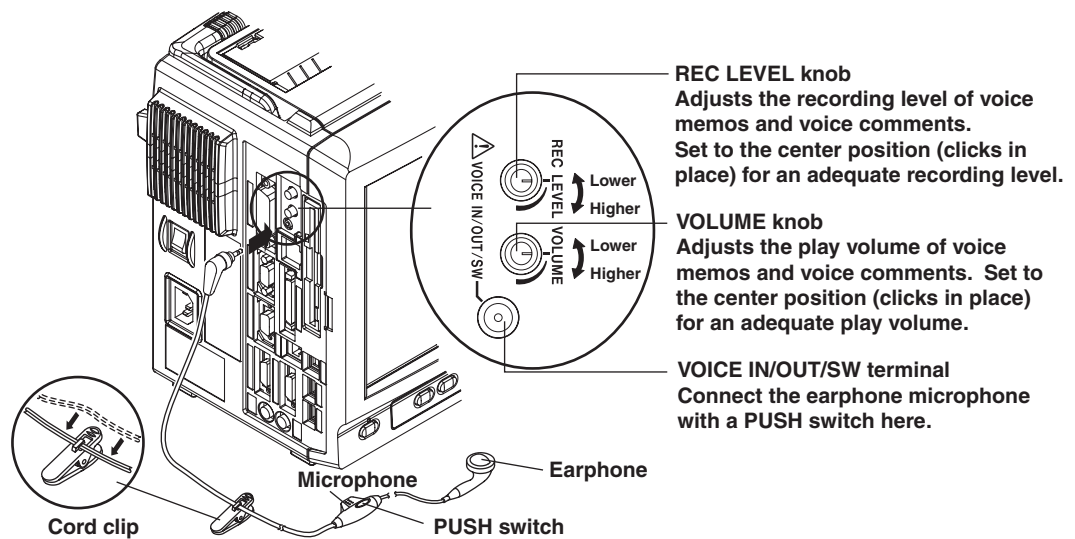

### Specifications of the Earphone Microphone with a PUSH Switch

#### Dynamic Inner Earphone

Input impedance: 32  $\Omega$   
 Frequency range: 100 to 20 kHz  
 Maximum input: 40 mW

#### Electric Condenser Microphone

Output impedance: 1.6 k $\Omega$   
 Frequency characteristics: 100 to 10 kHz  
 Directional characteristics: Omnidirectional  
 Code: 1.2 m,  $\phi 2.5$ , with 4-pin plug  
 Weight: Approx. 16 g

#### Earphone Microphone Jack Input/Output

Jack: 4-pin jack  
 Microphone input: Electric condenser microphone, input impedance of approx. 5 k $\Omega$   
 Earphone output: Dynamic, impedance of 32  $\Omega$   
 Switch input: 10-k $\Omega$  pull-up (3.3 V)

#### Note

- The specifications above apply to the optional earphone microphone with a PUSH switch (701951) that is sold separately. Operation of other earphone microphones are not guaranteed.
- There is no protection circuit, because it is a dedicated input. Be sure to use the dedicated earphone microphone by YOKOGAWA.



**Handling Precautions of the Earphone Microphone with a PUSH Switch**

- Do not place the earphone microphone in a humid environment. Do not spill water on the earphone microphone. This may cause a malfunction.
- Do not place the earphone microphone under direct sunlight, near a heater, or in hot or dusty environments.
- Do not apply strong shock. Do not pull on the cord.

**Circuit Diagrams of the Input/Output Section of the Earphone Microphone with a PUSH Switch**

**Microphone Input**

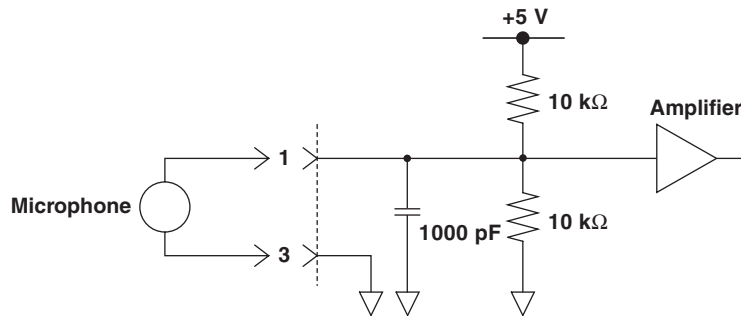

**Earphone Output**

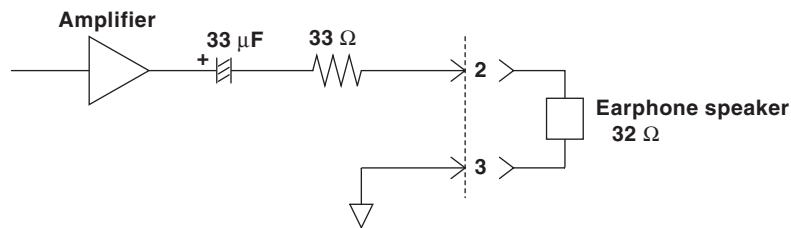

**Switch Input**

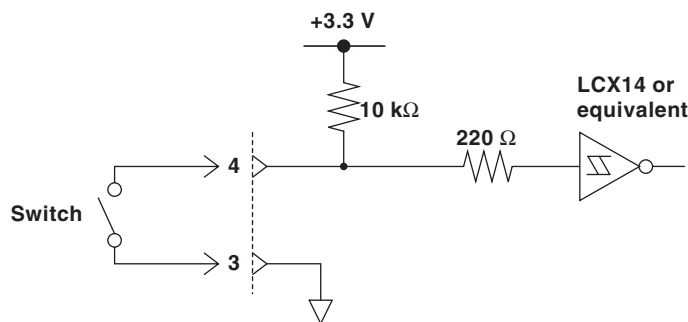

• **Plug polarity signal**

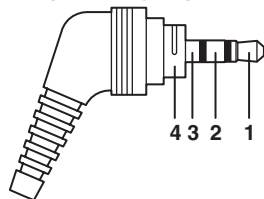

- 1 Microphone input
- 2 Earphone output
- 3 GND
- 4 Switch input

**Note**

- The circuit diagrams above apply to the optional earphone microphone with a PUSH switch (701951) that is sold separately. Operation of other earphone microphones are not guaranteed.
- There is no protection circuit, because it is a dedicated input. Be sure to use the dedicated earphone microphone by YOKOGAWA.

### Specifications of the Optional Speaker Cable (701952) (Sold Separately) and Connection Procedure

Use the speaker cable (701952) only to connect the DL750/DL750P to a speaker. For details on the connection of the speaker cable and the speaker, follow the instructions that came with the speaker.

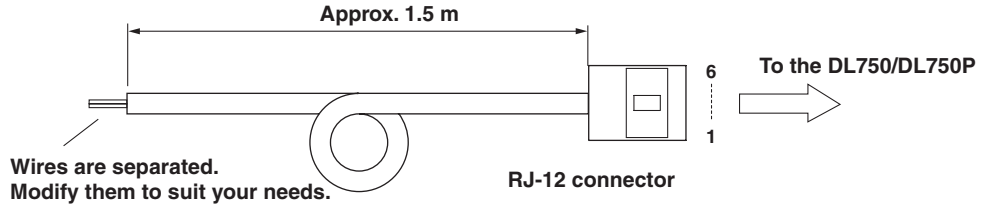

Wire Color	Pin No.	Signal Name
Blue	5	GND
White	6	SPEAKER



#### CAUTION

Do not short the speaker output signal or apply an external signal. Such act can lead to malfunction or fire.

#### Note

- For a speaker, use a commercially sold speaker with an impedance of 8 Ω.
- Depending on the speaker, a large sound may be produced even if the speaker volume of the earphone microphone is set properly. When using a speaker for the first time, set the speaker volume to the smallest setting. Some sound will be produced even if the volume is set to the minimum setting. If the sound is still large even with the smallest volume setting, turn the REC LEVEL knob on the left side panel at the time of recording to lower the recording level.

### Speaker Output Terminal (GO/NO-GO) Specifications

The terminal is shared with the GO/NO-GO I/O terminal of the DL750/DL750P side panel.

#### Type

Modular jack (RJ-12). For the cable, use the optional speaker cable (701952) that is sold separately.

#### Pin Arrangement

Pin No.	Signal Name
1	NC (no connection)
2	START IN
3	GO OUT
4	NOGO OUT
5	GND
6	SPEAKER

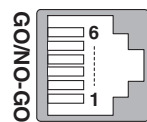

Connector on the DL750/DL750P

#### Circuit Diagram

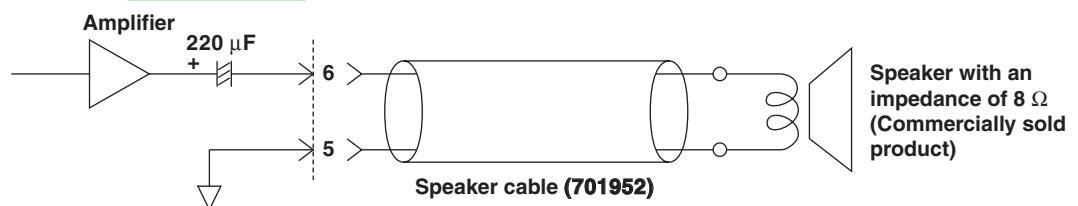

# 4.1 Operations and Functions of Keys and the Jog Shuttle

This section describes the basic operations of the keys and jog shuttle on the DL750/DL750P.

## Basic Key Operations

### Displaying the Setup Menu of Panel Keys

1. Press a key. The menu corresponding to the key appears.
2. Press the soft key corresponding to each item.

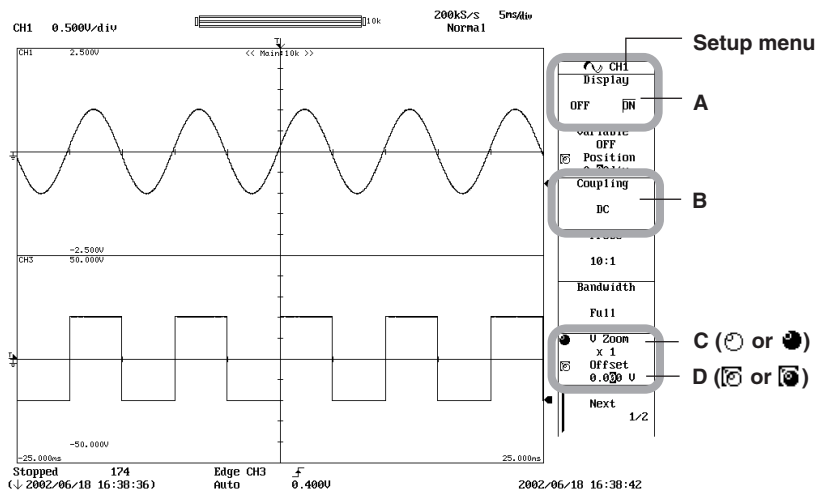

- A:** Press the corresponding soft key to switch the selection items.
- B:** Press the corresponding soft key to display the selection menu.  
Press the soft key corresponding to the selection to confirm the selection.
- C:** Press the corresponding soft key to set the item under jog shuttle control.  
Turn the jog shuttle to change the setting.
- D:** Press the corresponding soft key to set the item under jog shuttle control.  
Turn the jog shuttle to set the value.  
Press the arrow keys to move along the digits.  
You can directly enter the value using the NUM KEY or USB keyboard.

### Note

If the screen menu shows Next 1/2, you can press the soft key corresponding to Next 1/2 to show the 2/2 menu. To show the 1/2 menu again, press the soft key corresponding to Next 2/2.

### Displaying the Setup Menu Marked in Purple on the Panel

1. Press the **SHIFT** key. The indicator above SHIFT illuminates in green to indicate the shifted state. Functions marked in purple on the panel become active.
2. Press the key corresponding to the setup menu you wish to display.

## 4.1 Operations and Functions of Keys and the Jog Shuttle

### Operations on the Setup Dialog Box

1. Show the setup dialog box using basic key operations or other similar means.
2. Turn the **jog shuttle** to move the cursor to the desired item.
3. Press **SELECT**. The behavior that results when you press **SELECT** varies depending on the item as described below. This manual refers to the above operation as “**jog shuttle + SELECT**.”

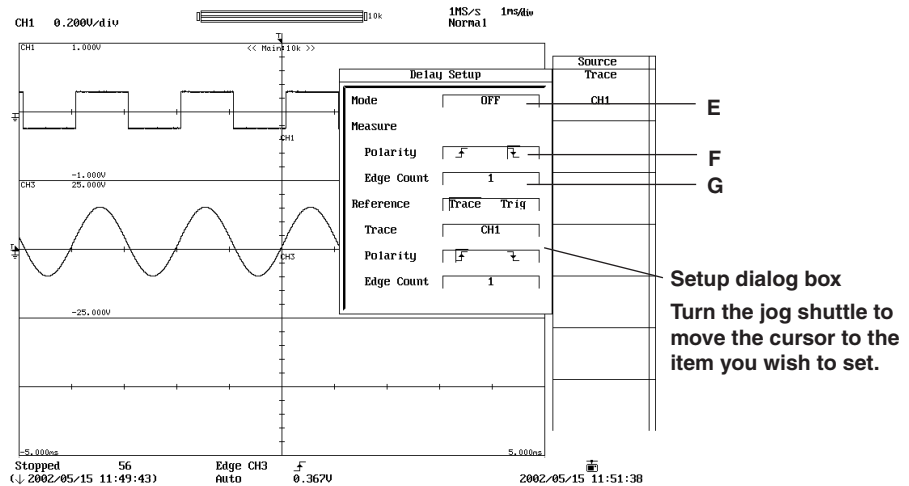

When Mode is selected

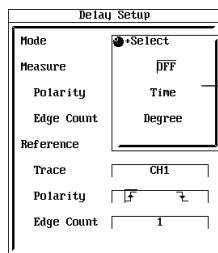

Selection menu

When Edge Count is selected

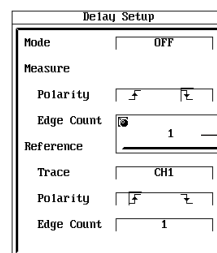

Value entry box

**E:** Press **SELECT** to display the selection menu.  
Turn the jog shuttle to move the cursor to the item you wish to set.  
Press **SELECT** to confirm the selection.

**F:** Press **SELECT** to switch the selection items.

**G:** Press **SELECT** to display the value entry box. Turn the jog shuttle to set the value.  
Press the arrow keys to move along the digits.  
You can directly enter the value using the **NUM KEY** or **USB keyboard**.

### Clearing the Menu and Setup Dialog Box Displays

1. Press **ESC**. The setup menu or setup box shown on top is cleared from the screen.

#### Note

- In the operating procedures in this manual, the step for clearing the setup menu and setup box is not indicated.
- When the setup menu is cleared, the main information on the displayed channels is shown. For details, see section 8.13.

## 4.2 Entering Values and Strings

### Entering Values

#### Entering Values Directly Using the Dedicated Knob

The dedicated knobs indicated below can be used to directly enter values by turning the knob.

- V/DIV knob
- TIME/DIV knob

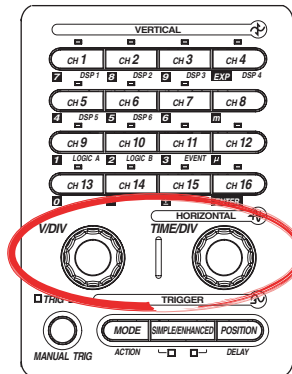

#### Entering Values Using the Jog Shuttle

After selecting the setup item using the soft key, use the jog shuttle to change the value. The outer shuttle ring can be used step through the values in large increments. On some items, the arrow keys below the jog shuttle can be used to move among the digits.

Resets the value to the initial value.

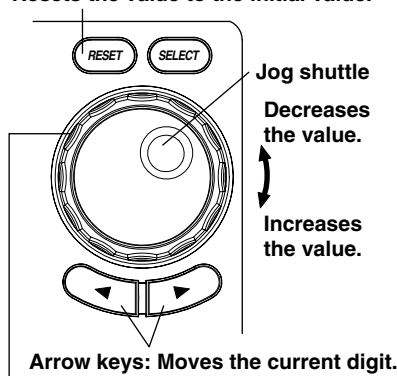

Shuttle ring

Parameters that can be specified using the jog shuttle

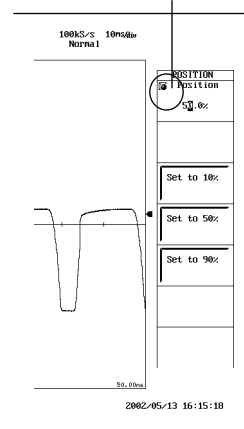

#### Note

The items that can be changed using the jog shuttle are reset to their initial values when the RESET key is pressed.

### Entering Strings

The keyboard displayed on the screen is used to enter character strings such as file names and comments. The jog shuttle, SELECT, and arrow keys are used to operate the keyboard to enter the character strings.

#### Operating the Keyboard

1. Turn the **jog shuttle** to move the cursor to the character to be entered. You can also press the soft keys corresponding to ▲ and ▼ to move the cursor vertically.
2. Press **SELECT**. The character is confirmed. If a character string is already been entered, move the cursor to the position in the string at which you want to enter a character.
3. Repeat steps 1 and 2 to enter all the characters in the string.
4. Selecting ENT on the keyboard and pressing **SELECT** confirms the string and the keyboard disappears. You can also press the ENT soft key to confirm the string and clear the keyboard. At the same time, the confirmed string is temporarily stored. If you wish to clear the entire string that you have entered, press **RESET** before confirming the string.

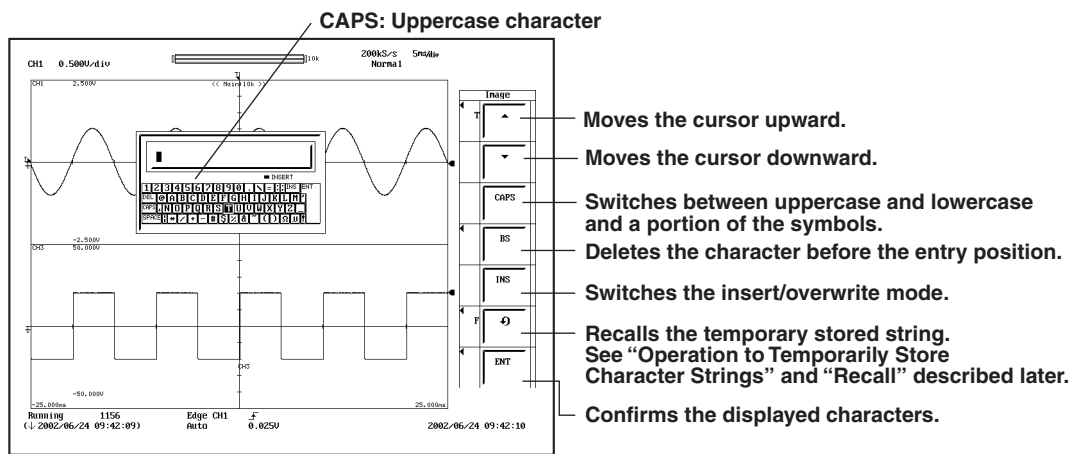

#### Note

When using the user-defined computation (option), a keyboard for setting the computation appears. The basic operation is the same, but see section 10.5 for details.

#### • Operation of Temporarily Storing the Character Strings

The strings that are previously confirmed are sequentially sent to the subsequent memories. When the number of confirmed strings exceeds eight, the strings are deleted in order starting from the oldest string. Symbols 0 to 7 are used in the explanation as a matter of convenience, but numbers 0 to 7 do not appear on the actual screen.

Symbol indicating the memory storing the string	0	1	2	.....	7
When string "AA" is confirmed first	Stores AA				
When string "BB" is confirmed next	Stores BB	Moves and stores AA			
When string "CC" is confirmed next	Stores CC	Moves and stores BB	Moves and stores AA		
.....					
When string "HH" is confirmed next	Stores HH	Moves and stores GG	Moves and stores FF	.....	Moves and stores AA
When string "JJ" is confirmed next	Stores JJ	Moves and stores HH	Moves and stores GG	.....	Moves and stores BB Deletes AA

- **Recalling Strings**

Note that the string that is displayed in the entry box of the keyboard is overwritten when a string is recalled using the procedure in step 1 below.

1. Every time the **↶** soft key is pressed, strings that are temporarily stored (strings that have been entered previously) appear in order in the input box of the keyboard. When the eight strings that are temporarily stored are displayed, the most recent string is displayed again.
2. Make appropriate corrections to the recalled string and confirm it according to steps 1 to 4 that were described in “Operating the Keyboard” on the previous page. At this point, the confirmed string is temporarily stored.

- **Keys Other Than the Character Keys**

DEL: Deletes the character at the cursor.

INS: Switches the insert/overwrite mode. When in insert mode, the INSERT indicator on the keyboard illuminates.

SPACE: Enters a space.

ENT: Confirms the displayed characters.

CAPS: Switches between uppercase and lowercase.



### Number of Characters and Types That Can Be Used in the Settings

Setup Item	Number of Characters	Characters That Can Be Used	Reference Section
Date/Time	Specified number	0 to 9	3.5
Waveform labels	1 to 8	All characters (including spaces)	8.10
Unit of linear scaling	0 to 4	All characters (including spaces)	5.11
File name	1 to 16	A to Z, %, _, (, )	13.7 to 13.11, 7.7
Comments for files	0 to 160	All characters (including spaces)	13.7 to 13.10, 7.7
Comments for screen images	0 to 20	All characters (including spaces)	13.11
Comments for printing	0 to 20	All characters (including spaces)	12.2
Message of annotation	0 to 80	All characters (including spaces)	9.4, 12.2
Comments for PDF files	0 to 20	All characters (including spaces)	13.13
Title, author, and sub title of PDF files	0 to 30	All characters (including spaces)	13.13, 9.9
Keyword of PDF files	0 to 90	All characters (including spaces)	13.13, 9.9
E-mail address	0 to 40	ASCII characters (including spaces)	16.5
Comments for e-mail	0 to 30	All characters (including spaces)	16.5
User name, login name, and password	0 to 15	ASCII characters (including spaces)	16.3, 16.6, 16.7

### Note

- The multiple @ characters cannot be entered consecutively.
- File names are not case-sensitive. Uppercase and lowercase are distinguished in comments. In addition, the following five file names cannot be used due to limitations of MS-DOS. AUX, CON, PRN, NUL, CLOCK, COM1 to COM9, LPT1 to LPT9

### Entering Values from the NUM KEY

When entering values for items with  or  icon, press the NUM KEY to display an area for directly entering values (black area). You can enter CH1 to CH16 keys of the VERTICAL group to enter values. The gray value marked below and to the left of each key can be entered.

When value entry using the NUM KEY is active,  is indicated at the upper left corner of the screen.

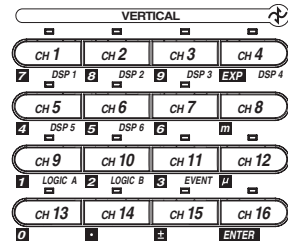

**Example: To enter 1.5 mV,  
press CH 9, CH 14, CH 6, CH 8, and CH 16.**

To clear the area for entering values, to escape, press the NUM KEY or CH16 (ENTER) again.



## 4.3 USB Keyboard/USB Mouse

### Entering Values from a USB Keyboard

You can connect a USB keyboard for entering file names, comments, and other information. In addition, the functions of each key on the front panel of the DL750/DL750P are assigned to the keys on the keyboard (see appendix 8). Thus, the keyboard can be used to carry out operations that are the same as the key operations on the DL750/DL750P.

#### USB PERIPHERAL Connector

To connect a USB keyboard to the DL750/DL750P, connect a USB cable to the USB PERIPHERAL connector on the left side panel. There are two USB PERIPHERAL connectors (ports).

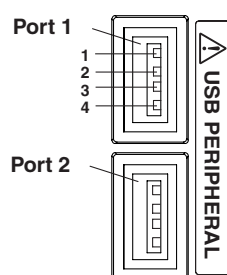

Pin No.	Signal Name
1	VBUS: +5 V
2	D-: -Data
3	D+: +Data
4	GND: Ground

#### Keyboards That Can Be Used

Keyboards that can be used depend on the type of USB Keyboard language that you selected in section 17.3 (English or Japanese). The following keyboards conforming to USB Human Interface Devices (HID) Class Ver1.1 can be used.

- When the USB Keyboard language is English: 104 keyboard and 89 keyboard
- When the USB Keyboard language is Japanese: 109 keyboard and 89 keyboard

#### Note

For USB keyboards that have been tested for compatibility, contact your nearest YOKOGAWA dealer.

### 4.3 USB Keyboard/USB Mouse

#### Connection Procedure

When connecting a USB keyboard, directly connect the keyboard to the DL750/DL750P using a USB cable as shown below. You can connect the USB cable regardless of the power ON/OFF state of the DL750/DL750P (supports hot-plug). Connect the type A connector of the USB cable to the DL750/DL750P; connect the type B connector to the keyboard. When the power switch is ON, the keyboard is detected and enabled approximately 6 s after it is connected.



#### Note

- Connect the keyboard directly without going through a USB hub.
- Do not connect USB devices other than USB keyboard, USB mouse, printer, and USB storage device to the USB PERIPHERAL connector.
- Do not connect multiple keyboards.
- Holding down a key on the keyboard does not enter the character or value repetitively.
- Do not connect and disconnect multiple USB devices repetitively. To do so, allow at least 10 s between connection and disconnection.
- Do not connect or disconnect the USB cable after the power is turned ON until key operation is ready (approximately 20 to 30 s).

#### Confirming the Keyboard That Is Connected

To confirm the keyboard that is connected to the DL750/DL750P, carry out the procedure below.

1. Press **MISC**.
2. Press the **USB** soft key.
3. Press the **USB List** soft key to display the USB Device List. Check the USB keyboard that is connected.

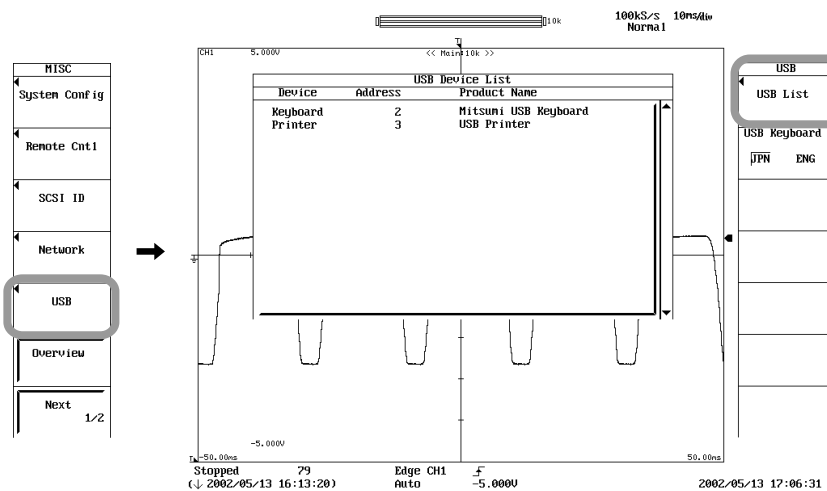



#### Entering File Names, Comments, and Other Items

When a keyboard is displayed on the screen, you can enter the file name, comment, and other items using a USB keyboard. The character that is entered through each key of the keyboard varies depending on the keyboard type. For details, see appendix 8.

### Executing Functions Corresponding to the Front Panel Keys of the DL750/DL750P

The functions corresponding to the front panel keys of the DL750/DL750P are assigned to the keys on the USB keyboard. By pressing the keys on the keyboard, you can operate the DL750/DL750P in a similar fashion. The assignment of functions varies depending on the keyboard type. For details, see appendix 8.

### Entering Values Directly from a USB Keyboard

You can directly enter values from a USB keyboard for items with  or  icon on the DL750/DL750P menu.

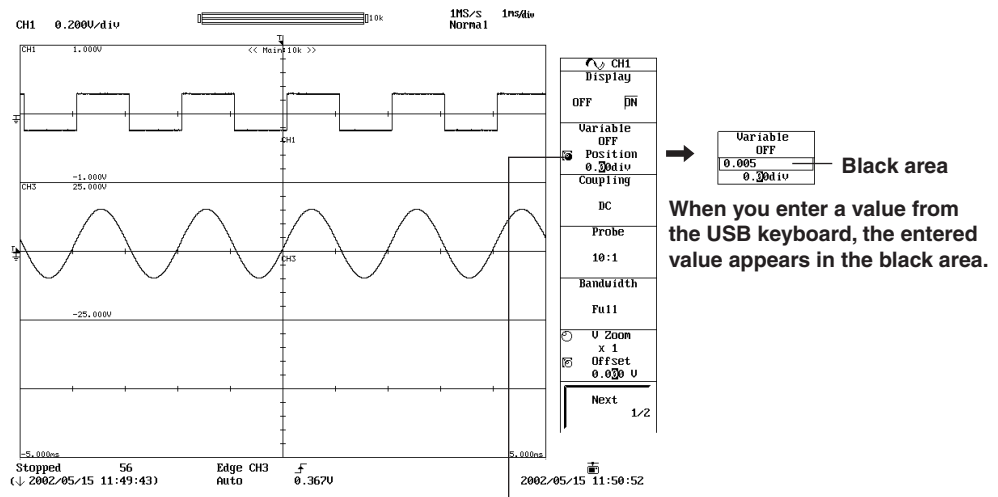

Press the soft key corresponding to the item, enter the value from the USB keyboard, and press the Enter key. The entered value is applied.

- **When a Prefix Unit Is Displayed**

For voltage (V) and time (s) items, you can also enter the prefix unit from the USB keyboard.

#### Example

Entering “1” “0” “m” for “Offset” is equivalent to entering “10 mV,” and the screen displays “0.01 V.” If you enter the prefix unit from a USB keyboard, you do not have to press the “Enter” key.

Below are the prefix units that can be entered.

Input Key	Prefix Unit
K or k	$10^3$ (kilo)
m	$10^{-3}$ (milli)
U or u	$10^{-6}$ (micro)
N or n	$10^{-9}$ (nano)
P or p	$10^{-12}$ (pico)

- **When Displayed in Exponential Notation**

You can also enter the menu items displayed in exponential notation from the USB keyboard.

#### Example

Entering “2” “.” “3” “E” “1” “Enter” for the menu item displaying “0.0000E+00” causes the value to be displayed as “2.3000E+01”.

### Operations Using a USB Mouse

You can use a USB mouse to operate the DL750/DL750P as you would using the front panel keys. In addition, you can point to a desired item on a menu and click the item. This is analogous to pressing a soft key corresponding to a menu and pressing the SELECT key.

#### **USB PERIPHERAL Connector**

The USB mouse is connected to the USB PERIPHERAL connector on the left side panel of the DL750/DL750P. For details on the USB PERIPHERAL connector, see page 4-7.

#### **USB Mouse That Can Be Used**

A USB mouse (with a wheel) conforming to USB HID Class Ver.1.1. can be used.

#### **Note**

- For USB mouse devices that have been tested for compatibility, contact your nearest YOKOGAWA dealer.
  - Some items cannot be specified when using a mouse without a wheel.
- 

#### **Connection Procedure**

When connecting a USB mouse, directly connect the mouse to the USB PERIPHERAL connector using a USB cable as shown below. You can connect/disconnect the USB mouse connector regardless of the power ON/OFF state of the DL750/DL750P (supports hot-plug). When the power switch is ON, the mouse is detected and enabled approximately 6 s after it is connected.

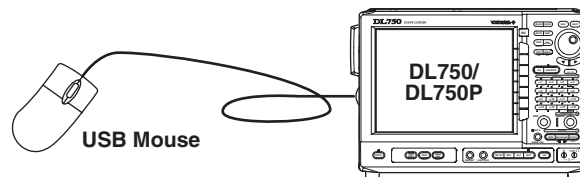

#### **Note**

- Do not connect USB devices other than USB keyboard, USB mouse, and USB printer to the USB PERIPHERAL connector.
  - There are two USB PERIPHERAL connectors on the DL750/DL750P. However, do not connect mouse devices to both connectors at the same time.
  - Do not connect and disconnect multiple USB devices repetitively. To do so, allow at least 10 s between connection and disconnection.
  - Do not connect or disconnect the USB cable after the power is turned ON until key operation is ready (approximately 20 to 30 s).
- 

#### **Confirming the USB Mouse That Is Connected**

The procedure for confirming the USB mouse that is connected to the DL750/DL750P is the same as the procedure for confirming the USB keyboard. See page 4-8.

### USB Mouse Operation

#### Operations Similar to the Front Panel Keys on the DL750/DL750P (Top Menu) Displaying the Top Menu

Right-click on the screen. The front panel keys on the DL750/DL750P are displayed as the top menu.

#### Selecting Items on the Top Menu

Point to the item you wish to select and left-click the item. The setup menu corresponding to the selected item is displayed on the right side of the screen. The top menu is cleared from the screen.

Pointing to an item with a sub menu (items with a > mark displayed to the right) displays the sub menu. As with the top menu, point to the item you wish to select and left-click the item.

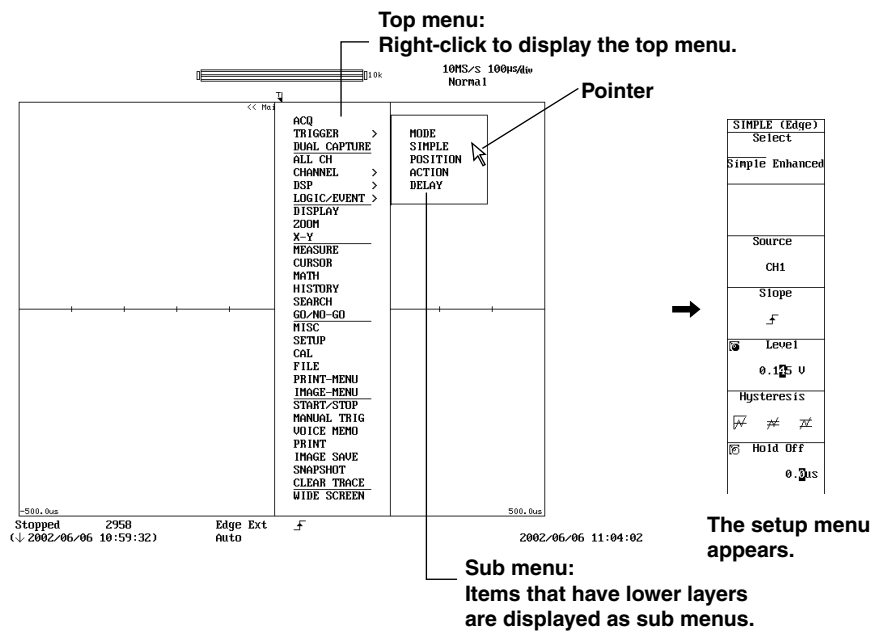

### Note

- The following keys do not appear on the top menu. ESC, RESET, SELECT, HELP, and arrow keys
- The top menu also displays characters that are indicated in purple on the front panel.
- The TRIGGER sub menu contains the following TRIGGER group keys. MODE, SIMPLE/ENHANCED, POSITION, ACTION, and DELAY
- There is no WIDE SCREEN key on the front panel.
- To display the PRINT menu or the IMAGE-SAVE menu, select PRINT-MENU or IMAGE-MENU. To execute the PRINT or IMAGE SAVE operation, select PRINT or IMAGE SAVE.

**Clearing the Top Menu**

Displaying the main setup information of each channel on the right side of the screen after clearing the top menu

Left-click on an area outside the top menu. The top menu is cleared, and the main setup information of the channel that is currently displayed is shown on the right side of the screen.

- **Expanding the Waveform Display Area after Clearing the Top Menu**

Left-click WIDE SCREEN on the top menu. The top menu is cleared, and the waveform display area is displayed expanded.

**Displaying the main setup information of each channel on the right side of the screen after clearing the top menu**

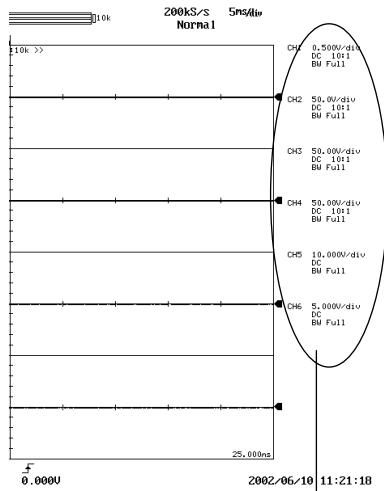

**Expanding the waveform display area after clearing the top menu**

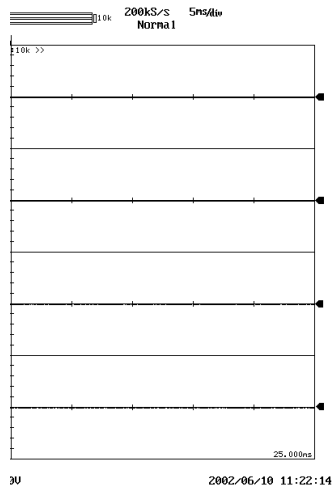

Main setup information of each channel

**Displaying the Shortcut Dialog Box**

As shown in the following figure, a shortcut menu is provided in addition to the setup menu so that certain items can be executed even while a dialog box or a window is open. The shortcut menu appears when you right-click on the screen while a dialog box or a window is open. In this case, the top menu is not displayed.

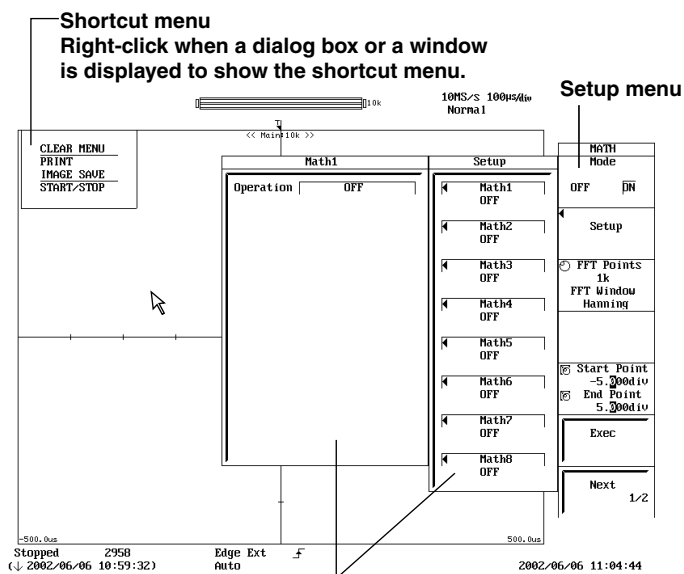

Dialog box other than the setup menu

• **Setup Menu Operation (Similar to the Soft Key Operation)**

**Selecting an Item on the Setup Menu**

Left-click the item you wish to select on the setup menu.

If another menu appears when you select an item, move the pointer to the new frame displaying the item you wish to select and left-click the item.

If an item such as ON or OFF appears when you select an item, move the pointer to the new frame containing the item and left-click the item. This operation switches the item.

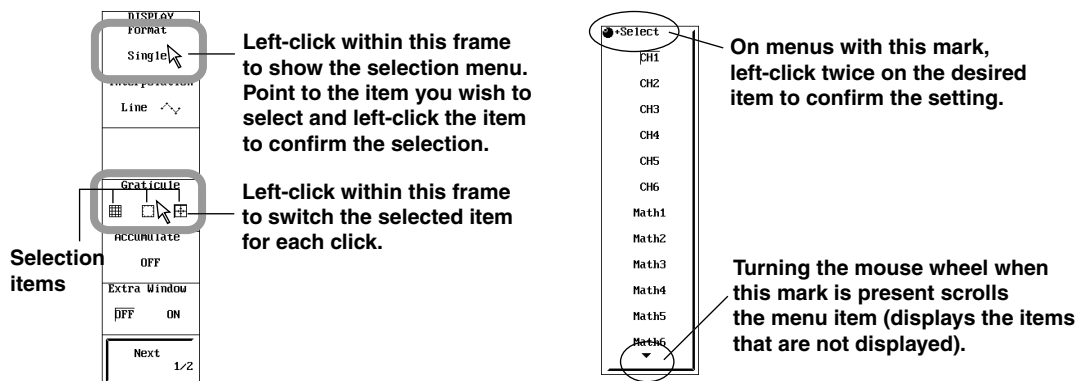

For menus in which items are selected using the jog shuttle and SELECT, left-click the desired item. Left-click again to confirm the new setting and close the selection dialog box. For items that you can scroll, turn the mouse wheel to scroll.







**Clearing the Menu Screen**

Left-click an area outside the menu screen.

• **Setting Values**

For menu items with a  or  icon, the numeric value can be entered as follows:

- To select a menu item with a  or  icon, left-click the center of the menu item. If there are two setup items in a single menu item, you can repetitively left-click to select either item.
- Turn the mouse wheel downward to increase the value.
- Turn the mouse wheel upward to decrease the value.
- To move to a different digit, left-click to the left or right of the value. At this point, the pointer changes to  or . If you point to the left of the value and left-click, the current digit moves to the left; if you point to the right of the value and left-click, the current digit moves to the right. The current digit moves one digit at a time for each left-click.
- To reset the value to default, right-click on the desired menu item.

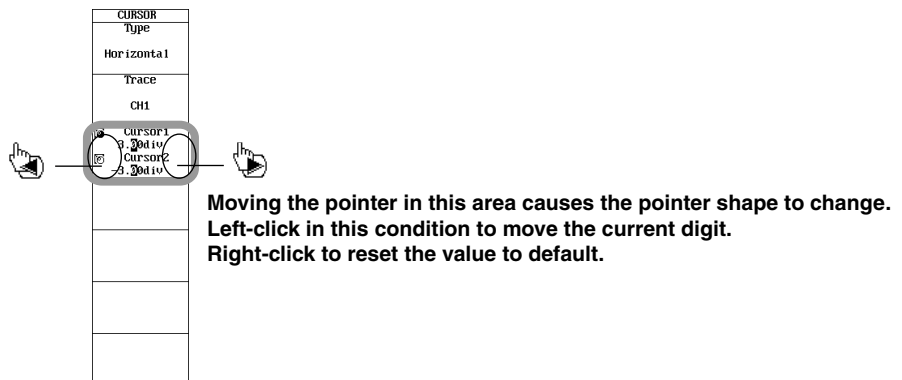

### 4.3 USB Keyboard/USB Mouse

- **Selecting Toggle Box Items on the Dialog Box**

- Left-click the item you wish to select. The item is selected. Click the selected item again to deselect it.
- To close the dialog box, point to an area outside the dialog box and left-click.



Left-click the item you wish to select.

**Note**

When closing an error dialog box, also point to an area outside the error dialog box and left-click.

- **Selecting a File, Directory, or Medium Drive on the File List Window**

- Left-click a file, directory, or medium drive name to select it.
- If a scroll bar is shown on the file list window, you can turn the mouse wheel to scroll the file list.
- To cancel the selection, point to an area outside the file list window and left-click. The selection is cancelled, and the file list window closes.

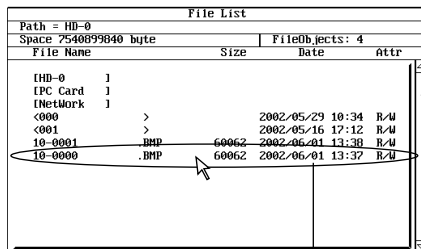

Scroll bar

Move the pointer to the file, directory, or storage medium drive you wish to select and left-click.



- **Setting V/DIV and TIME/DIV**

**Setting V/DIV**

When the waveform of a channel measuring a voltage is displayed, point near the V/DIV value displayed at the upper left corner of the screen. At this point, the pointer changes to . Turning the mouse wheel upward increases the V/div value; turning it downward decreases the V/DIV value.

**Setting TIME/DIV**

Point near the TIME/DIV value displayed at the upper right corner of the screen. At this point, the pointer changes to . Turning the mouse wheel upward increases the TIME/DIV value; turning it downward decreases the TIME/DIV value.

**Moving the pointer to the position indicated below changes the pointer display. You can change the V/DIV or TIME/DIV setting by turning the wheel in this condition.**

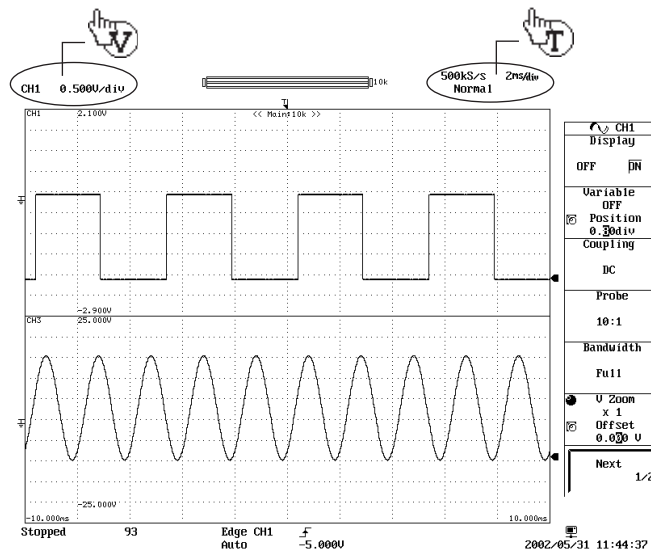

## 4.4 Initializing Settings

<For a description of this function, refer to page 2-61.>

### Procedure

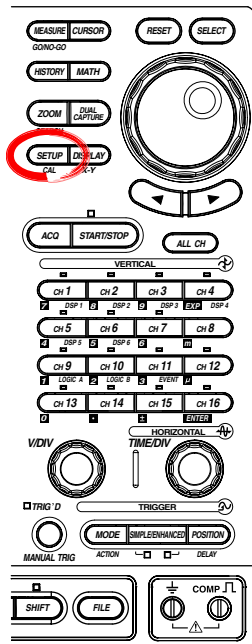

### Executing Initialization

1. Press **SETUP**.
2. Press the **Initialize** soft key. The settings are initialized.

### Canceling Initialization

3. Press the **Initialize Undo** soft key. The settings return to the conditions that existed immediately before initialization.

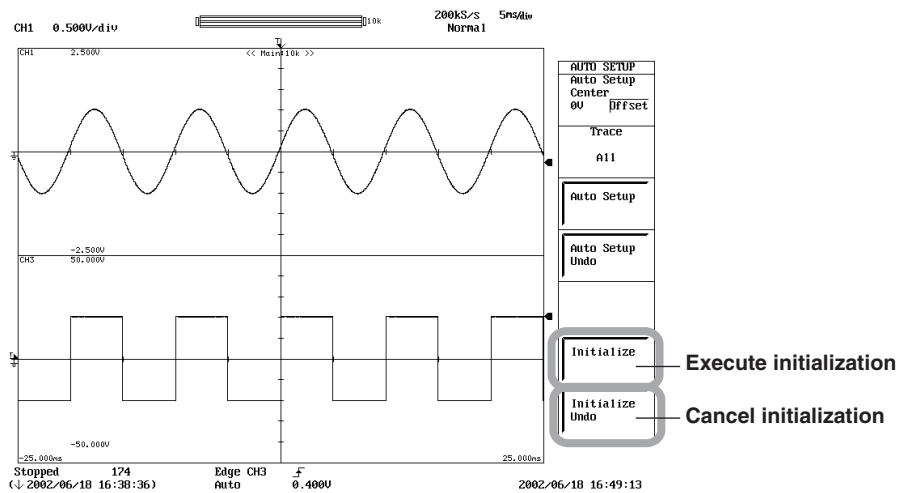

### Note

When you turn OFF the power switch, the settings that existed immediately before initialization are cleared. Therefore, the “Undo” operation is not possible in this case.

**Explanation**

The values specified using the keys can be reset to the factory default values. This is useful when you wish to clear previous settings or start the measurement from scratch.

**Initialization**

Initialization refers to the act of resetting the settings to factory default.

For a list of the factory default settings, see appendix 7, "List of Initial Values."

**Settings That Cannot Be Initialized**

- Date and time settings
- Settings related to communications and Ethernet interface
- SCSI ID number setting
- Menu/message language setting
- USB keyboard language setting
- Setting the time difference from GMT
- Setting the motor rotation of the internal hard disk

**Canceling Initialization**

If you initialize the settings by mistake, you can press the Undo soft key to set the DL750/DL750P back to the settings that existed before the initialization.

**Initializing All the Settings**

Turning ON the power switch while holding down RESET initializes settings related to communications and Ethernet interface and SCSI ID settings also. If you initialize the DL750/DL750P in this fashion, the settings cannot be set back to their original condition.

# 4.5 Performing Auto Setup

<For a description of this function, refer to page 2-62.>

## Procedure

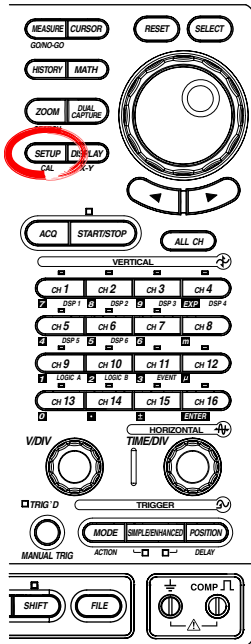

### Executing Auto Setup

1. Apply the signal to be measured.
2. Press **SETUP**.
3. Press the **Auto Setup Center** soft key to select 0 V or Offset.
4. Press the **Trace** soft key. The channel selection menu appears. The menu does not appear for channels without modules.
5. Turn the jog shuttle to select the target channel.
6. Press the **Auto Setup** soft key. Auto setup is executed. When auto setup is executed, waveform acquisition starts automatically.

### Canceling Auto Setup

7. Press the **Auto Setup Undo** soft key. The settings are set back to the original condition.

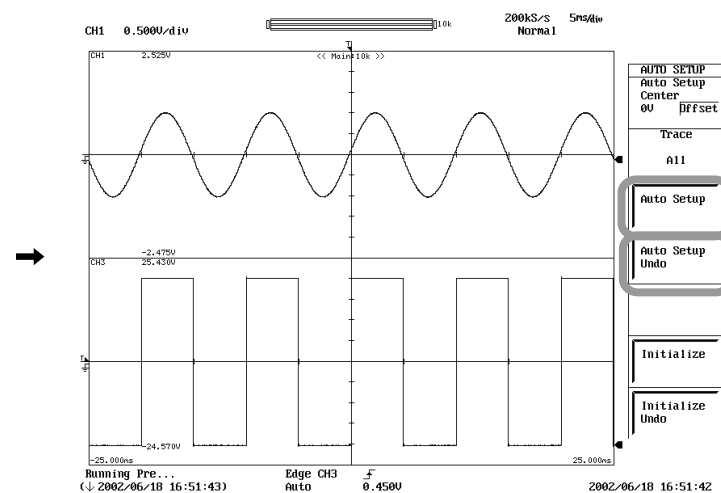
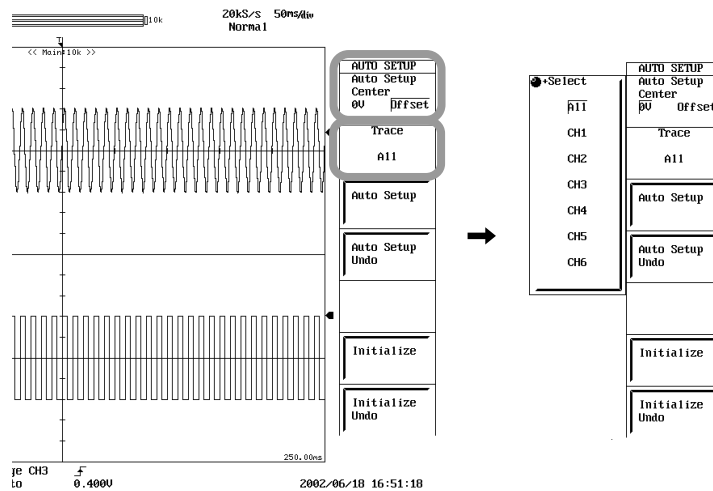

**Explanation**

The auto setup function automatically sets the settings such as V/div, T/div, and trigger level that are appropriate for the input signal.

**Center Position after Auto Setup**

0 V: Sets the center to 0 V. This is useful when you wish to view the relative relationship between the ground level and the waveform.

Offset: Sets the center to the offset value. This is useful when you wish to view the shape of the waveform by maximizing the amplitude.

**Target Channel**

Auto setup is performed on all channels or on the specified channel.

**Applicable Modules**

701250 (HS10M12), 701251 (HS1M16), 701255 (NONISO\_10M12), 701260 (HV (with RMS)), 701261 (UNIVERSAL), 701262 (UNIVERSAL (AAF)), and 701275 (ACCL/VOLT)

**Canceling Auto Setup**

Pressing the Undo soft key sets the DL750/DL750P back to the conditions that existed immediately before auto setup. However, when you turn OFF the power switch, the settings that existed immediately before auto setup are cleared. Therefore, the “Undo” operation is not possible in this case. The settings that existed immediately before auto setup are cleared if you execute initialization after auto setup.

**Applicable Waveforms for Auto Setup**

Frequency:	Approx. 50 Hz to 1 MHz
Absolute value of the input voltage:	Maximum value is between approximately 20 mV (1:1) and ((maximum range)×10)
Type:	Repetitive waveform (that is not complex) When the input coupling is set to DC

**Note**

The auto setup function may not work properly if the waveform includes DC components or high-frequency components.

## 4.5 Performing Auto Setup

---

### Setup Data after Executing Auto Setup

---

#### Waveform acquisition/display conditions

START/STOP	START
Acquisition mode	Normal
Number of acquisitions	Infinite
Record length	10 k
Time base	Int
Accumulate mode	OFF
Zoom target	Channels that are turned ON

---

#### Vertical-axis settings

V/div	Value that causes the absolute value of the input waveform to be 1.6 to 4.5 divisions
Offset voltage	0 V or the center value between the maximum and minimum values of the input signal
Coupling	DC
Bandwidth limit	FULL
Display ON/OFF	Turns ON channels whose absolute value of the input voltage is greater than or equal to 20 mV (1:1)
Position	0 division
Variable mode	OFF
V Zoom	×1
Scaling	OFF

---

#### Horizontal-axis settings

T/div	Value that displays 1.6 to 4 periods of the waveform with the shortest period of the auto setup target waveforms
-------	------------------------------------------------------------------------------------------------------------------

---

#### Trigger settings

Trigger mode	Auto
Trigger type	Simple
Trigger source	Channel whose waveform amplitude is greater than or equal to 1 division with the longest period
Trigger level/slope	Center level between the maximum and minimum values/ rising
Trigger coupling	DC
Hysteresis	$\frac{\Delta}{\Delta}$ (high sensitivity)
Hold off time	0.0 ns
Trigger position	50.0%
Trigger delay	0.0 $\mu$ s

---

#### Computation settings

Math	OFF
------	-----

---

#### Other settings

Realtime output	OFF
Dual Capture	OFF
Accumulation	
LOGIC A and LOGIC B display	OFF
EVENT display	OFF

---

Items other than those listed above are not applicable for auto setup.

#### Note

If none of the input waveforms are detected on the target module, the waveform acquisition is not started.

---

## 4.6 Performing Calibration

### Procedure

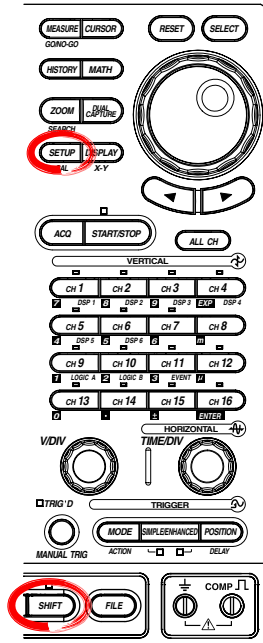

Calibrate the DL750/DL750P when observing voltages.

### Executing Calibration

1. Press **SHIFT+SETUP**.
2. Press the **Calibration** soft key to execute calibration.

### Perform Auto Calibration

3. Press the **AutoCal** soft key to select ON.

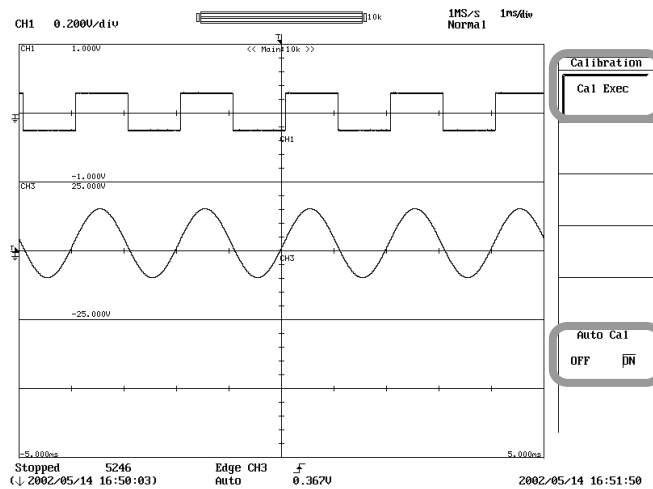

### Explanation

#### Calibration

The following parameters are calibrated. Perform calibration when you wish to measure waveforms with high accuracy.

- Ground level offset
- A/D converter gain

#### Precautions to Be Taken When Perform Calibration

- Always allow the instrument to warm up for at least 30 minutes after the power is turned ON before starting calibration. If calibration is performed immediately after the power is turned ON, the calibration may be inaccurate due to drift caused by fluctuation in the temperature of the instrument.
- Calibration must be performed when the temperature of the instrument is stable and is between 5°C and 40°C (preferably at 23°C±5°C).

#### Note

The calibration described above is performed automatically when power is turned ON or when the Cal Exec soft key in the Calibration menu is pressed.

#### Auto Calibration

If AutoCal is set to ON, auto calibration is performed the first time the time axis setting (T/div) is changed or the first time measurement is started after the time shown below passes.

After turning ON the power

- 3 minutes pass
- 10 minutes pass
- every 30 minutes from here on after

## 4.7 Using the Help Function

### Procedure

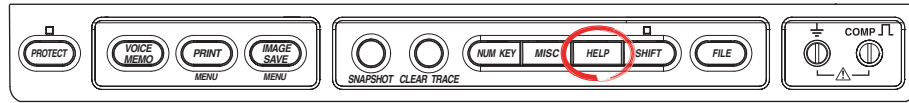

#### Displaying the Help Window

1. Press **HELP**.
2. Press the key or soft key that you wish to review.

#### Clearing the Help Window

3. Press **HELP** again.

### Explanation

#### Displaying the Help Window

When you press **HELP**, a help window containing information about the soft key menu or jog shuttle menu that was displayed immediately before **HELP** was pressed appears. A help window does not open on some keys.

If you press a key while the help window is displayed, a help window containing information about the key appears.

#### Clearing the Help Window

If you press **HELP** again while a help window is displayed, the help window closes.



# 5.1 Turning Channels ON/OFF

## Procedure

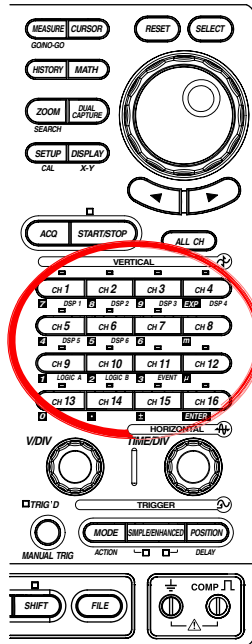

1. Press a key from **CH1** to **CH16** keys to select the desired channel.  
 To select a logic waveform, press **SHIFT+CH9 (LOGIC A)** or **SHIFT+CH10 (LOGIC B)**.  
 To select an event waveform, press **SHIFT+CH11 (EVENT)**.  
 To select a DSP channel (optional), press **SHIFT + CH1 (DSP1)** through **SHIFT + CH6 (DSP6)**.
2. Press the **Display** soft key to select ON or OFF. You can also turn ON/OFF the channel by pressing **CH1** to **CH16** twice.

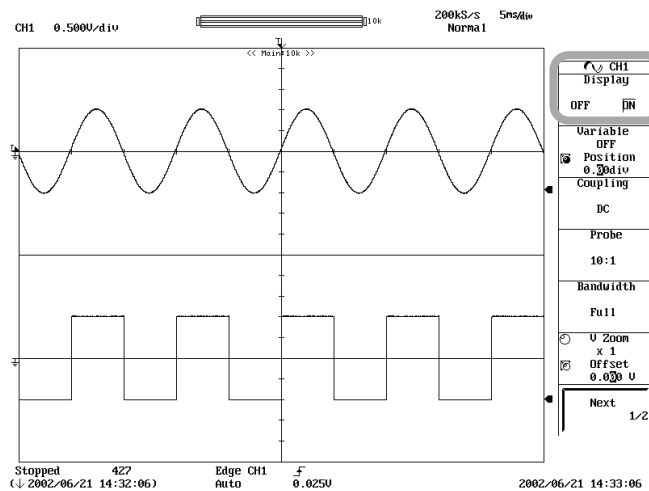

## Explanation

Input waveforms of CH1 to CH16, LOGIC A, and LOGIC B, DSP1 to DSP6 (optional), and event waveforms can be displayed simultaneously. For channels (CH1 to CH6) that are turned ON, the LED above the key illuminates.

### Note

- The screen can be split into up to eight display areas using the DISPLAY menu (section 8.1). Scale values (section 8.9) and waveform labels (section 8.10) can also be displayed.
- If waveforms are loaded from the history memory or from a storage medium such as a floppy disk, Zip disk, or PC card, the input waveform cannot be displayed. To compare waveforms, use the snapshot function.
- Channels that do not have input modules installed cannot be turned ON.
- A waveform icon is displayed to the left of the title of the CH1 to CH16, DSP1 to DSP6, LOGIC A/B, and EVENT setup menus. The icon color is set to the color of each waveform (see section 17.4). The icon shape varies depending on the displayed setup menu as follows:

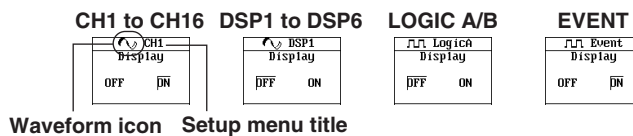

## 5.2 Setting T/div

<For a description of this function, refer to page 2-3.>

### Procedure

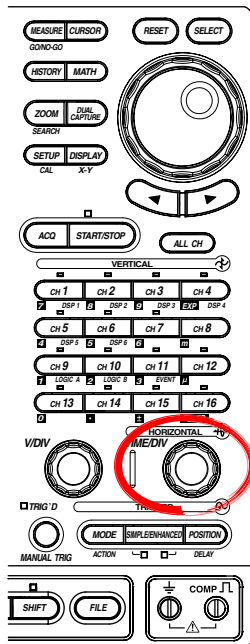

1. Turn the TIME/DIV knob to set the T/div value.

### Note

- If the TIME/DIV knob is turned while the waveform acquisition is stopped, the new T/div value is displayed within the parentheses at the upper right corner of the screen. The new T/div value becomes valid the next time acquisition is started.
- For details on the relationship between T/div and the sample rate, see appendix 1, "Relationship between the Time Axis Setting, Sample Rate and Record Length."
- For a description of the T/div setting of the sub waveform of the dual capture function, see section 7.6.

### Explanation

Set the time per division on the screen grid.

#### Selectable T/div Range

500 ns/div to 3 day/div

#### Maximum Sample Rate

The maximum sample rate varies depending on the input module as follows.

Input Module	Maximum Sample Rate
701250 (HS10M12)	10 MS/s (5 MS/s)
701251 (HS1M16)	1MS/s
701255 (NONISO_10M12)	10 MS/s (5 MS/s)
701260 (HV (with RMS))	100 kS/s
701261 (UNIVERSAL)	100 kS/s (when measuring voltage), 500 Hz (data update rate when measuring temperature)
701262 (UNIVERSAL (AAF))	100 kS/s (when measuring voltage), 500 Hz (data update rate when measuring temperature)
701265 (TEMP/HPV)	500 Hz (data update rate)
701270 (STRAIN_NDIS)	100 kS/s
701271 (STRAIN_DSUB)	100 kS/s
701275 (ACCL/VOLT)	100 kS/s
701280 (FREQ)	25 kHz (data update rate)

Values inside the parentheses are those when the DSP channel (optional) is ON.

### Note

The maximum sample rate of a DSP channel (optional) is 100 kS/s.

#### T/div and Roll Mode

The display switches to roll mode if T/div is set to 100 ms/div to 3 day/div under the following conditions.

- Acquisition mode is set to a mode other than averaging.
- The trigger mode is set to auto, auto level, single, or log.
- The time base is set to the internal clock signal.

## 5.3 Setting V/div

<For a description of this function, refer to page 2-3.>

### Procedure

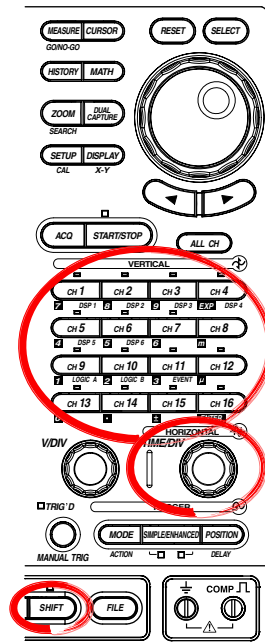

1. Press a key from **CH1** to **CH16** keys to select the desired channel.
2. Turn the **V/DIV** knob to set the V/div value.

### Explanation

#### V/div Setting (When Variable Is OFF)

The V/div (vertical sensitivity) setting is used to adjust the displayed amplitude of the waveform for easy viewing. Set the voltage per division on the screen grid. V/div is set using 1-2-5 steps (1 V/div -> 2 V/div -> 5 V/div). When Variable is set to OFF, the Position, V Zoom, and Offset settings are valid.

#### Note

- The displayed waveforms do not change, if you turn the V/DIV knob while the waveform acquisition is stopped. The new V/div value becomes valid the next time the waveform acquisition is started.
- Rotating the V/DIV knob while acquisition is stopped has no effect on cursor measurement and automated measurement of waveform parameters. The displayed values are for the V/div setting that existed when the measurement was made.

#### Selectable Range of V/div

The selectable range varies depending on the input module as follows.

Input Module	Selectable Range
701250 (HS10M12)	5 mV/div to 20 V/div
701251 (HS1M16)	1 mV/div to 20 V/div
701255 (NONISO_10M12)	5 mV/div to 20 V/div
701260 (HV (with RMS))	20 mV/div to 200 V/div
701265 (TEMP/HPV)	0.1 mV/div to 10 V/div
701275 (ACCL/VOLT)	5 mV/div to 10 V/div

The above values are given for a probe attenuation of 1:1. They will be 10 times the value shown when the probe attenuation is 10:1, 100 times the value shown when the probe attenuation is 100:1, and 1000 times the value shown when the probe attenuation is 1000:1.

### 5.3 Setting V/div

- **V/div Display**

If the V/DIV knob is turned while the waveform acquisition is stopped, the top row displays the V/div corresponding to the displayed waveform and the bottom row displays the new V/div. The new V/div value becomes valid the next time waveform acquisition is started.

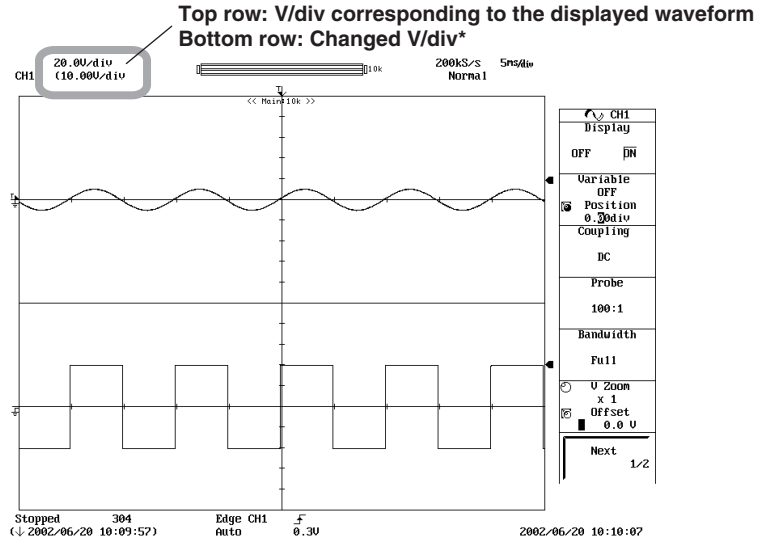

\* If the V/div corresponding to the displayed waveform and the changed V/div are the same, only the bottom row is displayed.

#### V/div Setting (When Variable Is ON)

Changing of the V/div signifies a change in the measurement range. When Variable is set to ON, the Upper and Lower settings become valid.

#### Note

If you turn the jog shuttle while acquisition is stopped and change the Upper and Lower values, the displayed waveforms also change.

- **V/div Display**

If the V/DIV knob is turned while the waveform acquisition is stopped, the top row displays the V/div corresponding to the displayed waveform and the bottom row displays the measurement range.

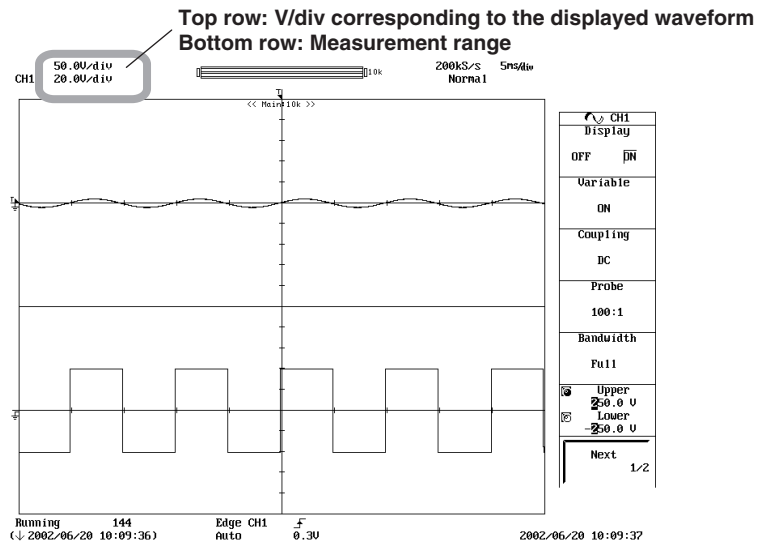

## 5.4 Setting the Vertical Position of Waveforms

<For a description of this function, refer to page 2-6.>

### Procedure

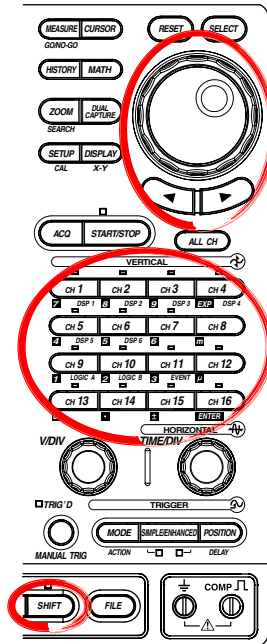

1. Press a key from **CH1** to **CH16** keys to select the desired channel. Proceed to step 2.  
To select a logic waveform, press **SHIFT+CH9 (LOGIC A)** or **SHIFT+CH10 (LOGIC B)**. Proceed to step 4.  
To select an event waveform, press **SHIFT+CH11 (EVENT)**. Proceed to step 4.  
To select a DSP channel (optional), press **SHIFT + CH1 (DSP1)** through **SHIFT + CH6 (DSP6)**.
2. Press the **Variable/Position** soft key. The Variable selection menu appears.
3. Press the **OFF** soft key. Check that Position is selected (☑).
4. Turn the **jog shuttle** to set the vertical position.

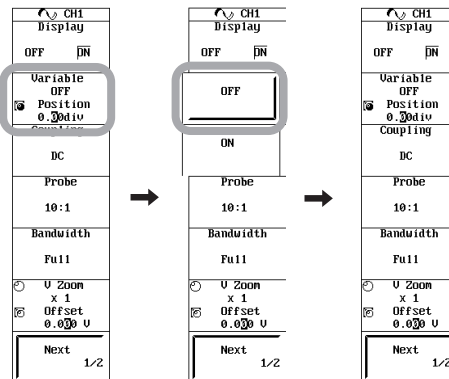

### Explanation

#### Range of Movement

The vertical position can be moved within a range of  $\pm 5$  divisions from the center of the waveform display frame.

#### Resolution

0.01 division

## 5.4 Setting the Vertical Position of Waveforms

---

### Confirming the Vertical Position

For input waveforms and computed waveforms, the ground level and vertical position are marked on the left of the waveform display frame.

500 mV/div, Offset: -1 V, Position: 0 div

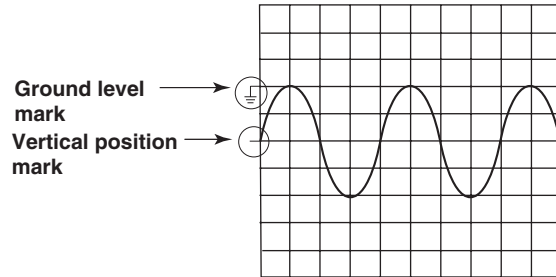

### Note

Data that exceeds the effective display range (see section 2.2) from changing the vertical position, offset voltage, or upper and lower limits (when Variable is ON) is handled as overflow data. Overflow data appears chopped as shown in the figure below.

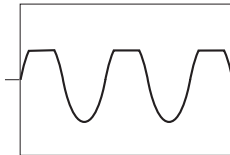

# 5.5 Setting the Input Coupling

<For a description of this function, refer to page 2-8.>

## Procedure

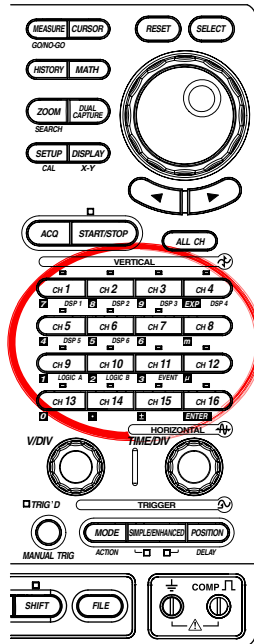

1. Press a key from **CH1** to **CH16** keys to select the desired channel.
  2. Press the **Coupling** soft key. The coupling selection menu appears.
  3. Press the soft key corresponding to the desired coupling.
- When observing temperature using the 701265 (TEMP/HPV), select TC.  
For the setup procedure of temperature measurements, see section 5.16.

**Input module:**  
701250(HS10M12)/701251(HS1M16)/  
701255(NONISO\_10M12)

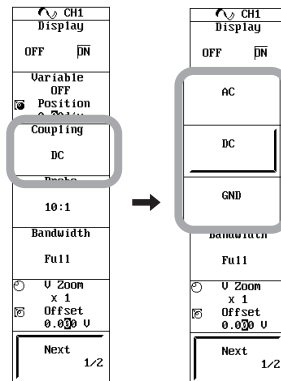

**Input module:**  
701261(UNIVERSAL)/  
701262(UNIVERSAL(AAF))/  
701265(TEMP/HPV)

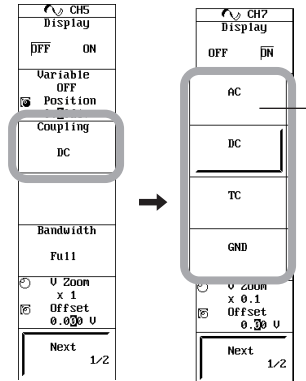

**AC is not available on the 701265.**

When observing rms values using the 701260 (HV (with RMS)), select AC-RMS or DC-RMS.

For the setup procedure of rms measurements, see section 5.15.

Select ACCL when measuring acceleration on the 701275 (ACCL/VOLT). For the setup procedure of acceleration measurements, see section 5.18.

**Input module:**  
701260(HV(with RMS))

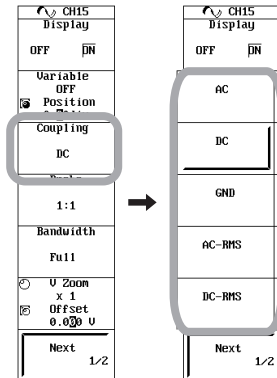

**Explanation**

**Selecting the Input Coupling**

Select how the input signal is coupled to the vertical control circuit from the following:

- AC: Acquires only the AC component of the input signal.
- DC: Acquires and displays all the components (DC and AC) of the input signal. Selectable only when observing voltage.
- GND: Checks the ground level.
- TC: Select this type when observing temperature.
- AC-RMS: Converts and displays only the AC component of the input signal.
- DC-RMS: Converts and displays both DC and AC components of the input signal.
- ACCL: Select this type when measuring acceleration.

**Input Coupling and Frequency Characteristics**

The frequency characteristics when AC and DC are selected are shown below. Note that low-frequency signals and signal components are not acquired if AC is selected as indicated in the figure below.

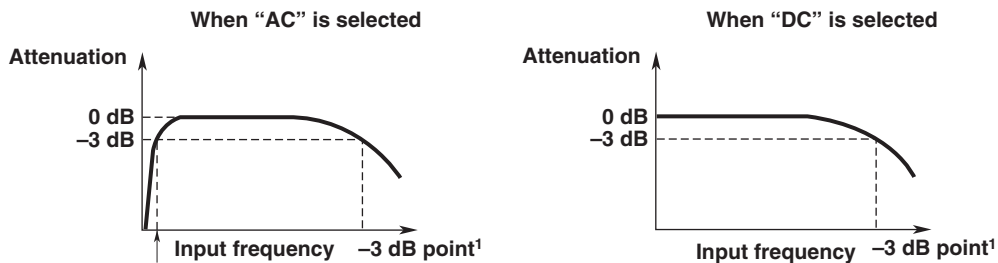

The lower frequency -3 dB point when using AC coupling\*

1. The value varies for each input module. For details, see chapter 19.12, "Module Specifications."

**Notes for the 701261, 701262, 701265, 701275, and 701280**

- If the input coupling is changed from TC to DC or DC to TC while the waveform acquisition is stopped on the 701261 (UNIVERSAL), 701262 (UNIVERSAL (AAF)), or 701265 (TEMP/HPV), the waveforms are no longer drawn. If you set the input coupling to the original setting, the waveforms are redrawn.
- If the input coupling is changed from ACCL to some other setting or some other setting to ACCL while the waveform acquisition is stopped on the 701275 (ACCL/VOLT), the waveforms are no longer drawn. If you set the input coupling to the original setting, the waveforms are redrawn.
- If you change the contents of the function of the FV setting while the waveform acquisition is stopped on the 701280 (FREQ), the waveforms are no longer drawn. If you set the contents of the function to the setting that was present during measurement, the waveforms are redrawn.



**CAUTION**

- If the input coupling is AC and the frequency of the input signal is less than 1 Hz, the DL750/DL750P does not attenuate the signal at the input terminal to 1/10, even if a probe with 10:1 attenuation and input resistance of 10 MΩ is used. Make sure not to input a voltage that has a signal component less than 1 Hz that exceeds the maximum input voltage of each module.
- Do not apply a voltage exceeding the maximum input voltage or maximum allowable common mode voltage of the input modules. This may cause damage to the input section.



## 5.6 Setting the Probe Type

<For a description of this function, refer to page 2-9.>

### Procedure

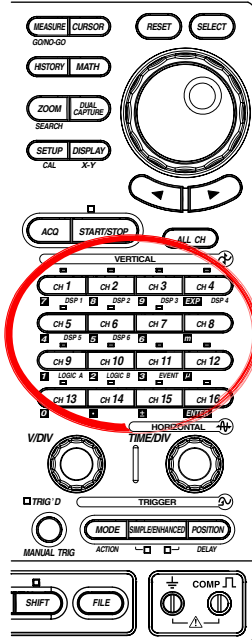

1. Press a key from **CH1** to **CH16** keys to select the desired channel.
2. Press the **Probe** soft key. The probe selection menu appears.
3. Press the soft key corresponding to the desired type (attenuation).

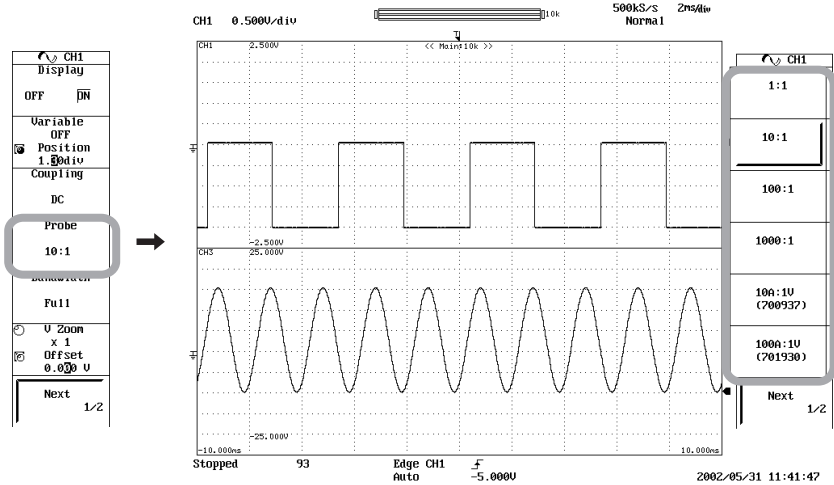

### Explanation

Select the appropriate probe type for each channel from the following:

1:1, 10:1, 100:1, 1000:1, 10 A:1 V, and 100 A:1 V

1:1 to 1000:1 represent the probe attenuation for voltage probes.

10 A:1 V and 100 A:1 V represent the output voltage rate of current probes.

### Note

If the probe type is not set correctly, the voltage and scale values of the input signals will not be displayed correctly. For example, if you set the attenuation to 1:1 when using a 10:1 probe, the displayed value for the waveform amplitude will be 1/10 the true value.

# 5.7 Setting the Bandwidth

<For a description of this function, refer to page 2-9.>

## Procedure

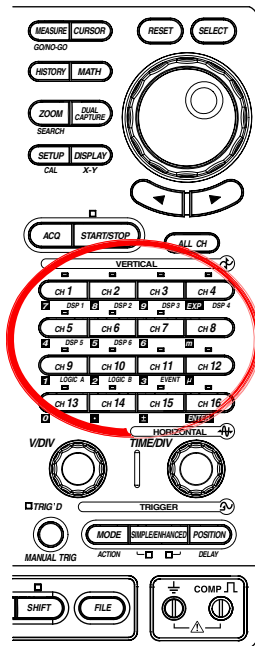

1. Press a key from **CH1** to **CH16** keys to select the desired channel.
2. Press the **Bandwidth** soft key. The bandwidth selection menu appears.
3. Press the soft key corresponding to the desired bandwidth. (The possible choices vary depending on the module.)
4. As necessary, repeat steps 1 to 3.

701250(HS10M12)/  
701255(NONISO\_10M12)

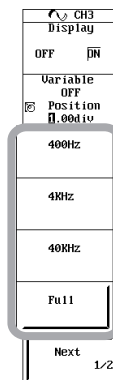
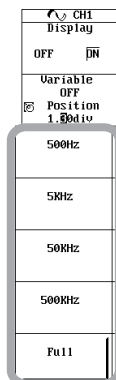
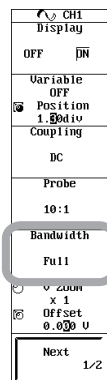

701265(TEMP/HPV)  
701261(UNIVERSAL)\*1/  
701262(UNIVERSAL(AAF))\*1



\*1 When measuring voltage

701260  
(HV(with RMS))

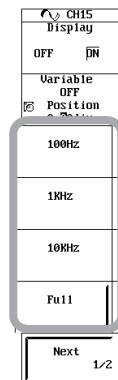

701270(STRAIN\_NDIS)/  
701271(STRAIN\_DSUB)

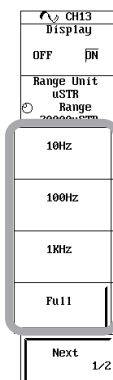

701275(ACCL/VOLT)  
701261(UNIVERSAL)\*2/  
701262(UNIVERSAL(AAF))\*2

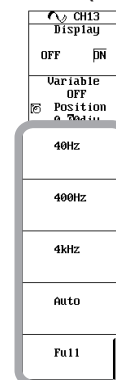

\*2 When measuring temperature

Auto is not available on the 701261.

### Note

The bandwidth is set for each channel. Set the bandwidth for all necessary channels.

**Explanation****Selecting the Bandwidth Limit**

High frequency components can be eliminated from the input signal. The bandwidth varies depending on the input module as follows. For the bandwidth limit of the 701280 (FREQ), see page 5-51.

Input Module	Bandwidth
701250 (HS10M12) 701255 (NONISO_10M12)	500 Hz, 5 kHz, 50 kHz, 500 kHz, and Full
701251 (HS1M16)	400 Hz, 4 kHz, 40 kHz, and Full
701260 (HV (with RMS))	100 Hz, 1 kHz, 10 kHz, Full
701261 (UNIVERSAL)* <sup>1</sup> 701262 (UNIVERSAL (AAF))* <sup>1</sup> 701265 (TEMP/HPV)	2 Hz, 8 Hz, 30 Hz, and Full
701270 (STRAIN_NDIS)/ 701271 (STRAIN_DSUB)	10 Hz, 100 Hz, 1 kHz, Full
701261 (UNIVERSAL)* <sup>2</sup> 701262 (UNIVERSAL (AAF))* <sup>2</sup> 701275 (ACCL/VOLT)	40 Hz, 400 Hz, 4 kHz, Auto, Full

\*<sup>1</sup> When measuring temperature

\*<sup>2</sup> When measuring voltage. Auto is not available on the 701261.

For example, frequency bandwidths of 400 Hz, 4 kHz, and 40 kHz are available on the 701251 (HS1M16). The frequency characteristics when bandwidth is limited are shown below. When Full is selected, the maximum bandwidth of the input module is used.

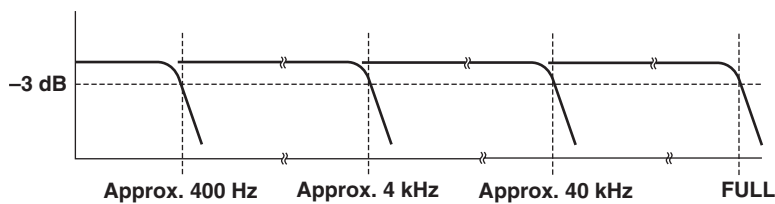
**Bandwidth Limit on the 701262 (UNIVERSAL (AAF)) and 701275 (ACCL/VOLT)**

If you set the bandwidth limit on the 701262 (UNIVERSAL (AAF)) when measuring voltage or the 701275 (ACCL/VOLT) to Auto, the anti-aliasing filter and low-pass filter settings are set to values shown below according to the sample rate.

Sample Rate	Anti-aliasing Filter	Low-pass filter
200 kS/s or greater	40 kHz	OFF
100 kS/s	40 kHz	OFF
50 kS/s	20 kHz	OFF
20 kS/s	8 kHz	OFF
10 kS/s	4 kHz	4 kHz
5 kS/s	2 kHz	4 kHz
2 kS/s	800 Hz	4 kHz
1 kS/s	400 Hz	400 Hz
500 S/s	200 Hz	400 Hz
200 S/s	80 Hz	400 Hz
100 S/s	40 Hz	40 Hz
50 S/s	20 Hz	40 Hz
5 S/s to 20S/s	20 Hz	40 Hz
2 S/s or less	20 Hz	40 Hz
Ext sample	40 kHz	OFF

For example, for sample rates between 100 kS/s to 50 kS/s, the cutoff frequency of the anti-aliasing filter is set to 40% of the sample rate.

## 5.8 Zooming Vertically by Setting the Zoom Rate

<For a description of this function, refer to page 2-7.>

### Procedure

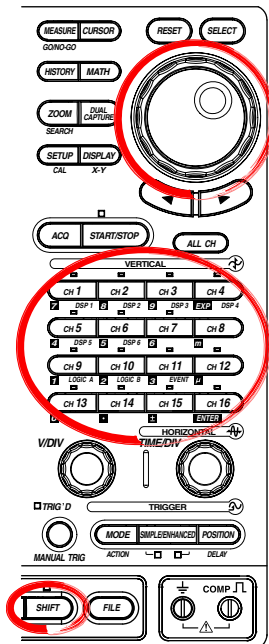

1. Press a key from **CH1** to **CH16** keys to select the desired channel.  
To select a logic waveform, press **SHIFT+CH9 (LOGIC A)** or **SHIFT+CH10 (LOGIC B)**.  
To select an event waveform, press **SHIFT+CH11 (EVENT)**.  
To select a DSP channel (optional), press **SHIFT + CH1 (DSP1)** through **SHIFT + CH6 (DSP6)**.
2. Press the **Variable** soft key to select OFF.
3. Press the **V Zoom/Offset** soft key (the **V Zoom** soft key for logic input) to set the jog shuttle control to V Zoom.
4. Turn the **jog shuttle** to set the zoom rate.

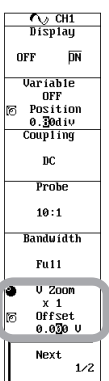
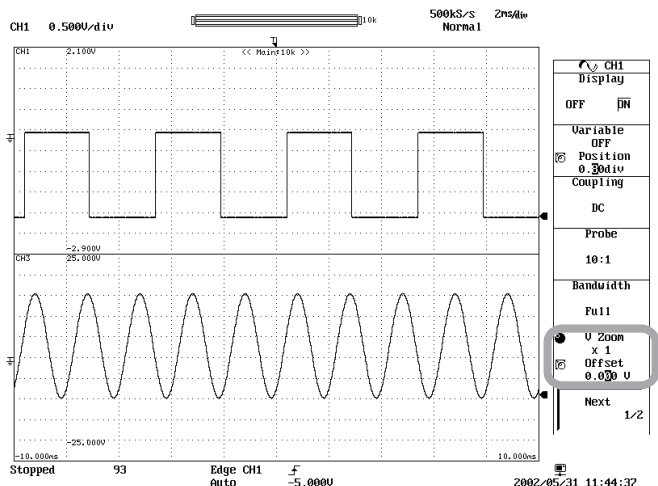
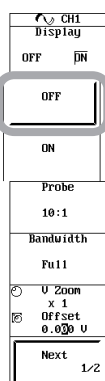
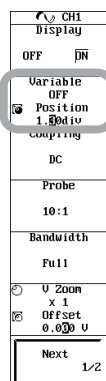

### Note

- Pressing the **RESET** key while the jog shuttle control is set to V Zoom sets the zoom rate to  $\times 1$ .
- When zooming in on the waveforms vertically using V Zoom, the V/div indication (upper left corner of the screen) shows the V/div corresponding to the displayed waveform in the top row and the value being entered using the V/DIV knob in the bottom row.

**Explanation**

The displayed waveform can be enlarged/reduced vertically. This is useful when you wish to change the vertical axis setting after displaying waveforms. This function can be used when the Variable setting is OFF.

**Selecting the Trace to Zoom On**

Select a single waveform from CH1 to CH16, LOGIC A, LOGIC B, DSP1 to DSP6 (optional), and EVENT.

However, zooming is not possible if the selected waveform is turned OFF.

**Zoom Rate: V Zoom**

The following zoom rates are available.

$\times 0.1$ ,  $\times 0.111$ ,  $\times 0.125$ ,  $\times 0.143$ ,  $\times 0.167$ ,  $\times 0.2$ ,  $\times 0.25$ ,  $\times 0.33$ ,  $\times 0.4$ ,  $\times 0.5$ ,  $\times 0.556$ ,  $\times 0.625$ ,  $\times 0.667$ ,  $\times 0.714$ ,  $\times 0.8$ ,  $\times 0.833$ ,  $\times 1$ ,  $\times 1.11$ ,  $\times 1.25$ ,  $\times 1.33$ ,  $\times 1.43$ ,  $\times 1.67$ ,  $\times 2$ ,  $\times 2.22$ ,  $\times 2.5$ ,  $\times 3.33$ ,  $\times 4$ ,  $\times 5$ ,  $\times 6.67$ ,  $\times 8$ ,  $\times 10$ ,  $\times 12.5$ ,  $\times 16.7$ ,  $\times 20$ ,  $\times 25$ ,  $\times 40$ ,  $\times 50$ , and  $\times 100$

However, the range of zoom rates that can be specified varies for the following cases.

- **On the 701260 (HV (with RMS))**  
When set to 50 V/div:  $\times 0.25$  to  $\times 100$   
When set to 100 V/div:  $\times 0.5$  to  $\times 100$   
When set to 200 V/div:  $\times 1$  to  $\times 100$
- **When measuring acceleration on the 701275 (ACCL/VOLT)**  
 $\times 0.5$  to  $\times 50$
- **On the 701280 (FREQ)**  
 $\times 0.33$  to  $\times 100$

**Zoom Position**

The waveform is zoomed around the vertical position.

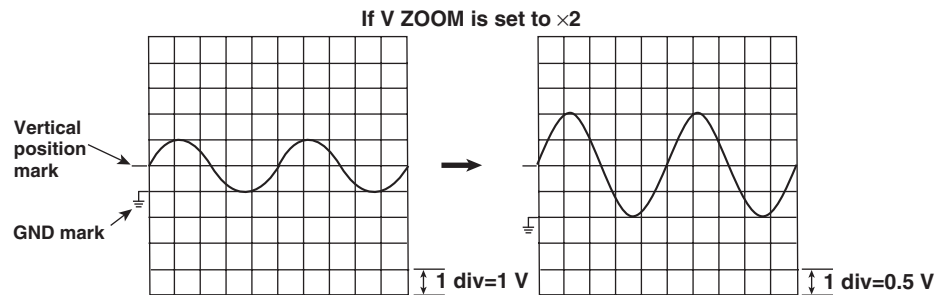

# 5.9 Zooming Vertically According to the Upper and Lower Limits of the Display Range

<For a description of this function, refer to page 2-7.>

## Procedure

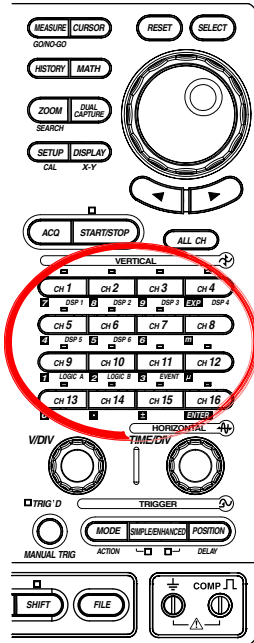

1. Press a key from **CH1** to **CH16** keys to select the desired channel.  
To select a DSP channel (optional), press **SHIFT + CH1 (DSP1)** through **SHIFT + CH6 (DSP6)**.
2. Press the **Variable/Position** soft key. The Variable selection menu appears.
3. Press the **ON** soft key.

### Setting the Upper Limit

4. Press the **Upper/Lower** soft key to set the jog shuttle control to Upper.
5. Turn the **jog shuttle** to set the upper limit.

### Setting the Lower Limit

6. Press the **Upper/Lower** soft key to set the jog shuttle control to Lower.
7. Turn the **jog shuttle** to set the lower limit.

### Setting the Upper and Lower Limits Simultaneously

8. Press the **Upper/Lower** soft key to set the jog shuttle control to both Upper and Lower.
9. Turn the **jog shuttle** to set the upper and lower limits without changing the spacing between the two.

### Note

Pressing RESET sets the maximum and minimum values of the measurement range to the upper and lower limits.

- When observing voltage Upper: 10 times +V/div, Lower: 10 times -V/div  
Upper: +FS, Lower: -FS
- When observing strain Upper: 5000/(gain × sensitivity)  
Lower: -5000/(gain × sensitivity)
- When measuring frequency and other parameters on the frequency module  
Upper: (Offset value) + (Value/div × 30)  
Lower: (Offset value) - (Value/div × 30)

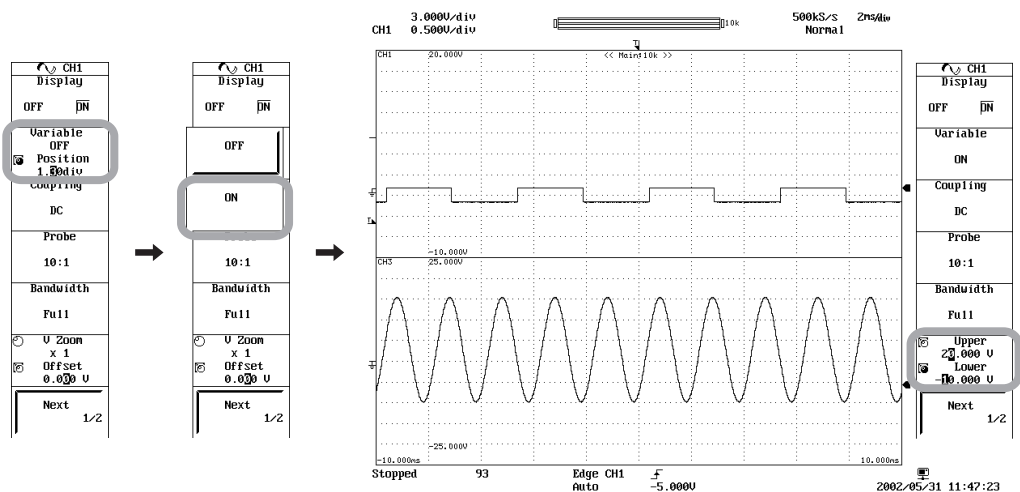

**Explanation****Zooming Vertically According to the Upper and Lower Limits of the Display Range:****Variable**

You can select whether to zoom vertically according to the upper and lower limits of the display range.

- **ON**

You can zoom in on the desired section of the observed waveform by specifying the upper and lower limits of the vertical axis according to the displayed waveform. Conversely, you can widen the display range to view waveforms outside the display range. The A/D conversion resolution and accuracy remain the same as those for the original waveform, when the waveform is expanded/reduced with Variable turned ON.

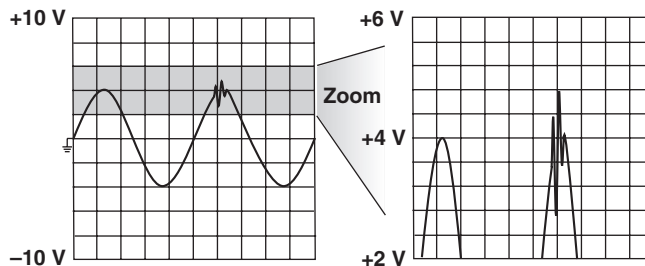

- **OFF**

Does not zoom vertically using the upper and lower limit settings. In this case, the vertical position (section 5.4), vertical zoom by setting the zoom rate (section 5.8), and offset voltage (section 5.10) can be changed.

**Selectable Range of Upper and Lower Limits**

Up to the smaller of the two values  $\pm(100 \text{ times the specified V/div})$  or 2000 V. Make sure the upper limit value (Upper) is greater than the lower limit value (Lower).

- Below are the ranges on the 701270 (STRAIN\_NDIS) and 701271 (STRAIN\_DSUB) according to the range unit.

When the range unit is  $\mu\text{STR}$ :  $\pm 30000 \mu\text{STR}$

When the range unit is mV/V:  $\pm 15 \text{ mV/V}$

- Up to  $\pm 2000000$  unit on the 701275 (ACCL/VOLT).
- Up to (offset value)  $\pm (\text{Value/div} \times 30)$  on the 701280 (FREQ).
  - When measuring the frequency:  $-1500 \text{ Hz to } 1700 \text{ Hz}$
  - When measuring RPMs:  $-300 \text{ krpm to } 350 \text{ krpm}$
  - When measuring RPSs:  $-5000 \text{ rps to } 7000 \text{ rps}$
  - When measuring the period:  $-150 \text{ s to } 200 \text{ s}$
  - When measuring the duty cycle:  $-500\% \text{ to } 700\%$
  - When measuring the pulse width:  $-150 \text{ s to } 200 \text{ s}$
  - When measuring the pulse integration:  $-2.5\text{E}+22 \text{ to } 2.5\text{E}+22$
  - When measuring the velocity:  $-2.5\text{E}+22 \text{ to } 2.5\text{E}+22$
- Up to  $\pm(100 \text{ times the specified Value/div})$  on the optional DSP channel.

**Note**

Changing V/div using the V/DIV knob after setting the upper and lower limits does not change the V/div setting on the screen, but changes the measurable range. If you set the measurable range smaller than the specified upper and lower limits and start the waveform acquisition, the section of the waveform exceeding the measurable range may not be displayed. The measurable range is approximately  $\pm 10$  divisions (around 0) when Variable is OFF.

# 5.10 Setting the Offset Value

<For a description of this function, refer to page 2-6.>

## Procedure

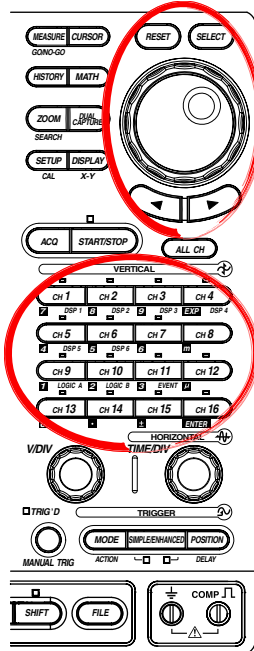

### Setting the Offset Value

1. Press a key from **CH1** to **CH16** keys to select the desired channel.
2. Press the **Variable** soft key to select OFF.
3. Press the **V Zoom/Offset** soft key to set jog shuttle action to Offset.
4. Turn the **jog shuttle** to set the offset value.

### When Resetting the Offset Value to 0 V

5. Press **RESET** to set the offset voltage to 0 V.

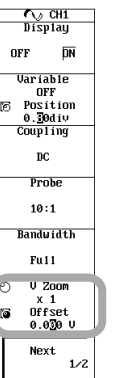
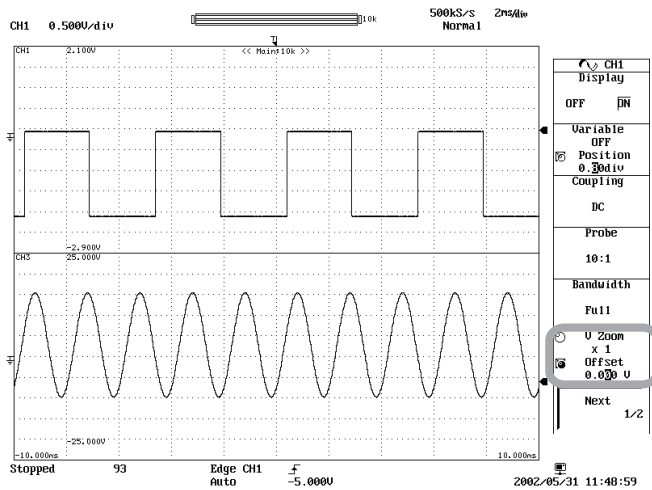
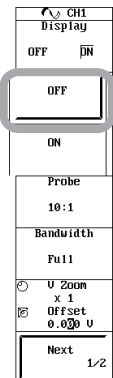
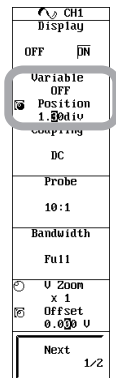



**Explanation**

The offset value is valid when measuring voltage, or frequency and other parameters on the frequency module.

**Selectable Range of Offset Value**

When measuring voltage:  $\pm 5$  div

On the frequency module, the range varies depending on the measured parameter.

- When measuring the frequency:  $\pm(\text{Value/div value}) \times 1000$  or 200 kHz
- When measuring RPMs:  $\pm(\text{Value/div value}) \times 1000$  or 50 krpm
- When measuring RPSs:  $\pm(\text{Value/div value}) \times 1000$  or 1000 rps
- When measuring the period:  $\pm(\text{Value/div value}) \times 1000$  or 50 s
- When measuring the duty cycle:  $\pm(\text{Value/div value}) \times 1000$  or 100%
- When measuring the pulse width:  $\pm(\text{Value/div value}) \times 1000$  or 50 s
- When measuring the pulse integration:  $\pm(\text{Value/div value}) \times 1000$  or 1.0000E+22
- When measuring the velocity:  $\pm(\text{Value/div value}) \times 1000$  or 1.0000E+22

**Resetting the Offset Value**

Pressing RESET resets the offset value to 0.

**Notes When Setting the Offset Value**

- When measuring voltage, the offset voltage is effective even when the acquisition is stopped. When measuring frequency and other parameters on the frequency module, the changes you make on the offset value are invalid when the acquisition is stopped. The new offset value takes effect on the next measurement.
- If you change the probe attenuation when measuring voltage, the offset changes proportionally to reflect the new attenuation rate.
- When measuring voltage, changing the voltage sensitivity does not change the offset value. If the change would cause the offset to go outside the range, the offset moves to the nearest range limit at the current voltage sensitivity. If you then return to the original sensitivity, the offset returns to its original setting as well (provided that you have not explicitly changed the value in the meantime).

**Note**

---

Changing the offset voltage allows the waveform position to be changed with respect to the vertical position. (The center for the vertical zoom can be changed.)

---

# 5.11 Using the Linear Scaling Function (AX+B, P1-P2)

<For a description of this function, refer to page 2-10.>

## Procedure

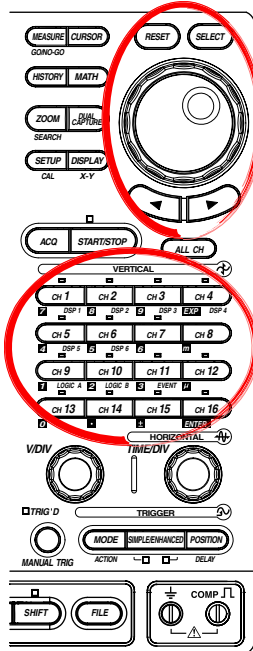

### Selecting Linear Scaling

1. Press a key from **CH1** to **CH16** keys to select the desired channel.
2. Press the **Next 1/2** soft key.
3. Press the **Linear Scale** soft key. A Linear Scale setup dialog box appears.
4. Use **SELECT**, **jog shuttle**, and **SELECT** to set Mode to AX+B or P1-P2.

### When AX+B Is Selected

5. Use **SELECT** and the **jog shuttle** to set A (scaling coefficient).
6. Use **SELECT** and the **jog shuttle** to set B (offset voltage).

### Setting the Unit

7. As necessary, enter the Unit according to the procedures given in section 4.2.

When measuring voltage on the voltage module or strain on the strain module, proceed to step 8.

### Setting the Display Type

8. Use **SELECT** and the **jog shuttle** to set Mode under Display Type to Exponent or Floating.

9. If Floating was selected in step 8, use **SELECT** and the **jog shuttle** to set Decimal Number and SubUnit.

Select the number of digits to the right of the decimal from Auto, 0 to 3.

Select the sub unit from Auto, p, n, μ, m, None, k, M, G, and T.

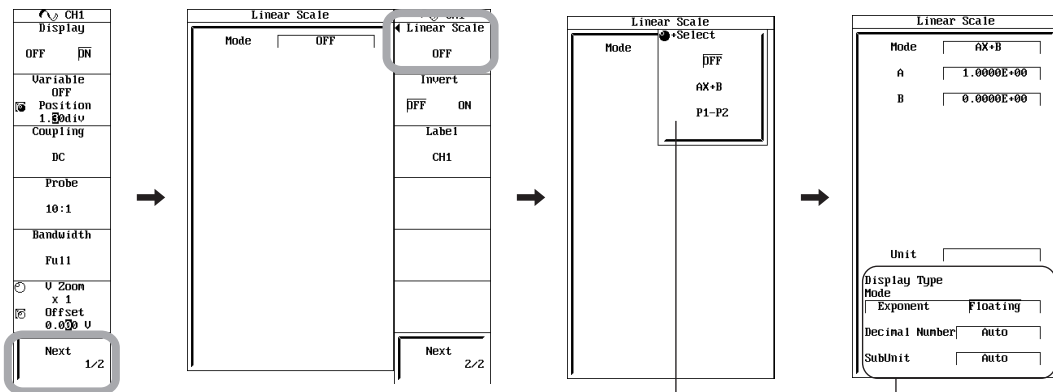

When measuring voltage on the voltage module or strain on the strain module, the setup items for display type is displayed.

On the 701271 (STRAIN\_DSUB), "Shunt" is displayed. The Shunt item is used to perform shunt calibration on the strain module. For the setup procedure of Shunt, see section 5.17.

- **When P1-P2 Is Selected**

5. Use **SELECT** and the **jog shuttle** to set the P1:X value. Or, turn the **jog shuttle** to select Get Measure P1:X and then press **SELECT** to read the measured value into P1:X.
6. Use **SELECT** and the **jog shuttle** to set the P1:Y value.
7. Use **SELECT** and the **jog shuttle** to set the P2:X value. Or, turn the **jog shuttle** to select Get Measure P2:X and then press **SELECT** to read the measured value into P2:X.
8. Use **SELECT** and the **jog shuttle** to set the P2:Y value.

- **Setting the Unit**

9. As necessary, enter the Unit according to the procedures given in section 4.2. When measuring voltage on the voltage module or strain on the strain module, proceed to step 10.

- **Setting the Display Type**

10. Use **SELECT** and the **jog shuttle** to set Mode under Display Type to Exponent or Floating.
11. If Floating was selected in step 8, use **SELECT** and the **jog shuttle** to set Decimal Number and SubUnit. Select the number of digits to the right of the decimal from Auto, 0 to 3. Select the sub unit from Auto, p, n,  $\mu$ , m, None, k, M, G, and T.

Linear Scale		CH1
Mode	P1-P2	Linear Scale
P1:X	0.0000E+00	P1-P2
P1:Y	0.0000E+00	Invert
P2:X	1.0000E+00	OFF ON
P2:Y	1.0000E+00	Label
Get Measure P1:X	Exec	CH1
Get Measure P2:X	Exec	
Unit		
Display Type		
Mode	Exponent Floating	
Decimal Number	auto	
SubUnit	auto	
		Next 2/2

When measuring voltage on the voltage module or strain on the strain module, the setup items for display type is displayed.

### Note

- Linear scaling is not possible when observing temperature or acceleration.
- Linear scaling is not available for the following waveforms.
  - Snapshot waveforms
  - Accumulated waveforms (excluding the newest waveform)
- Linear scaling is set for each channel.
- The scaling coefficient A and offset value B that you entered are held even if you turn OFF the linear scaling function.
- Computation is performed using the linear scaling results.

### Explanation

There are two linear scaling methods available: AX+B and P1-P2.

#### Selecting the Linear Scaling Method

Select the linear scaling method from the following:

- **OFF**

No linear scaling.

- **AX+B**

The results obtained from the following computation based on the specified scaling coefficient A and offset B are displayed as cursor measurement values and automated measurement values of waveform parameters. You can also assign a unit to the result of linear scaling.

$$Y = AX + B \text{ (where X is the measured value and Y is the linear scaling result)}$$

## 5.11 Using the Linear Scaling Function (AX+B, P1-P2)

- **P1-P2**

Specify arbitrary scale values (P1:Y and P2:Y) for the measured values of two arbitrary points (P1:X and P2:X). The scale conversion equation ( $y = ax + b$ ) is derived from these four values.

- Range of measured values (P1:X, P2:X): Same as the measurement range.
- Range of scale values (P1:Y, P2:Y):  $-1.0000E+25$  to  $+1.0000E+25$
- Initial setting of scale values: P1:X= $+0.0000E+00$ , P1:Y= $+0.0000E+00$   
P2:X= $+1.0000E+00$ , P2:Y= $+1.0000E+00$

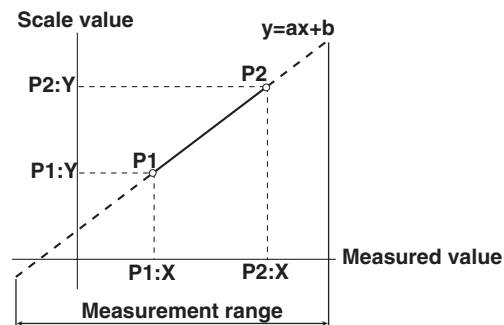

### Setting AX+B

- **Setting Scaling Coefficient A and Offset Value B**

Selectable range of A and B:  $-9.9999E+30$  to  $+9.9999E+30$

Initial setting of A:  $+1.0000E+00$

Initial setting of B:  $+0.0000E+00$

### Setting P1-P2

- **Reading Measured Values: Get Measure**

Regardless of whether the waveform acquisition is started or stopped, the current value (value indicated by the level indicator) can be read into P1:X or P2:X.

### Setting the Unit

Alphanumeric characters that can be entered: Up to 4 characters

### Display Type

When measuring voltage on the voltage module or strain on the strain module, select the display type for the linear scaling result from the two choices below.

Exponent: Exponential display.

Floating: Decimal display. Use Decimal Number to select the number of digits to the right of the decimal from Auto, 0 to 3. Use SubUnit to select the sub unit from Auto, p, n,  $\mu$ , m, None, k, M, G, and T.

- Decimal Number: When a setting between 0 and 3 is selected, the selected number of digits is displayed to the right of the decimal point. When Auto is selected, the value is displayed using 5 digits total (example: 1.0000 and 250.00). The initial setting is Auto.
- SubUnit: If a setting other than Auto is selected, the value is displayed using the specified sub unit. If Auto is selected, the most suitable unit for the value is automatically set. The initial setting is Auto. If the value cannot be displayed using a decimal value, exponential display is enabled.

### Displaying the Scale Value

The linearly scaled values of the upper and lower limits of the vertical axis of each channel can be displayed. For details, see section 8.9.

# 5.12 Inverting Waveforms

<For a description of this function, refer to page 2-10.>

## Procedure

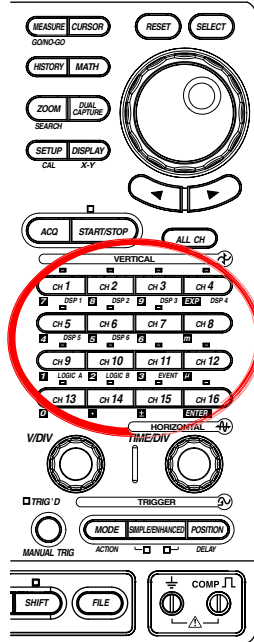

1. Press a key from **CH1** to **CH16** keys to select the desired channel.
2. Press the **Next 1/2** soft key.
3. Press the **Invert** soft key to select ON.

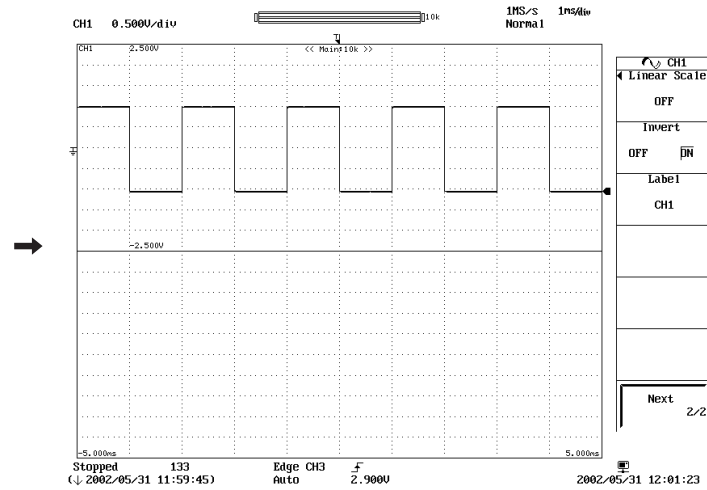
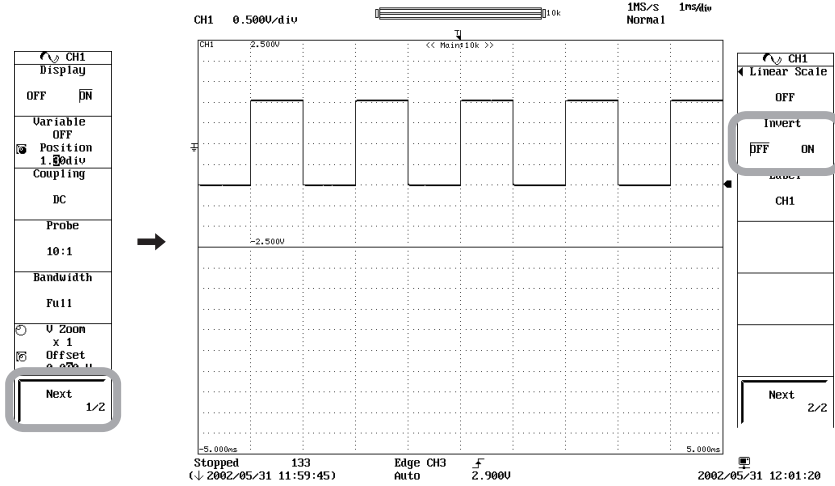

## Explanation

### Channel to Be Inverted

The input signals to channels CH1 to CH16 can be inverted independently. The waveform is inverted around the vertical position.

### Notes When Inverting Waveforms

- Cursor measurements, automated measurement of waveform parameters, and computation are performed on the inverted waveform.
- The trigger function is executed on the original waveform even if the waveform is inverted.
- When measuring strain, inversion is not possible on waveforms after measurements. The invert ON/OFF change takes effect on the next measurement.

# 5.13 Displaying the All Channel Setup Menu

## Procedure

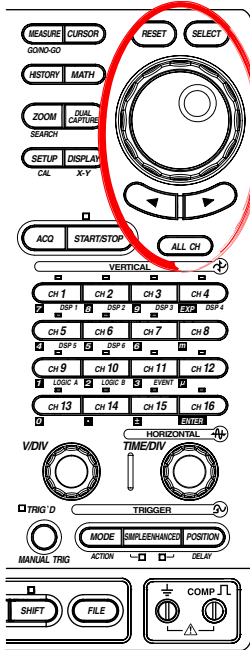

### Displaying the All Channel Setup Menu

1. Press **ALL CH**.
2. Press the **V/Div, Range Offset etc., Lin-Scale, Unit etc.,** or **DSP CH** (optional) soft key to show the setup menu.
3. Turn the **jog shuttle** or press the arrow keys to move the cursor to the desired parameter.
4. Press **SELECT** to display the setup menu for the selected parameter.
5. Use the **jog shuttle, SELECT,** and arrow keys to set each parameter.

#### • V/Div, Range Offset etc.

Setup												
No.	Disp	V/div	Var.	Position	Offset	V200m	Probe	Cpl	Band			
		Gain	Unit	Lower	Upper	R/C	Excit	GF				
A11	ON	500	OFF	0.00dV	250.0 U	x 1	10:1	DC	Full			
CH1	ON	500	OFF	0.00dV	0.00 U	x 1	10:1	DC	Full			
CH2	OFF	500	OFF	0.00dV	0.00 U	x 1	10:1	DC	Full			
CH3	OFF	500	OFF	0.00dV	0.00 U	x 1	10:1	DC	Full			
CH4	OFF	500	OFF	0.00dV	0.00 U	x 1	10:1	DC	Full			
CH5	OFF	50	OFF	0.00dV	0.000 U	x 1	1:1	DC				
CH6	OFF	50	OFF	0.00dV	0.000 U	x 1	1:1	DC				
CH7	ON	K	OFF	-200.0C	1300.0C	ON	BoutOFF	TC	Full			
CH8	ON	50	OFF	0.00dV	0.000 U	x 1		DC	Full			
CH9	ON	10mV/U	OFF	-10.0000mV	10.0000mV			20	2.00	Full		
CH10	ON	20000uSTR	STR	-20000uSTR	20000uSTR			20	2.00	Full		
CH11	ON	10mV/U	OFF	-10.0000mV	10.0000mV			20	2.00	Full		
CH12	ON	20000uSTR	STR	-20000uSTR	20000uSTR			20	2.00	Full		
CH13	ON	5mV	OFF	0.00dV	0.000mV	x 1	1:1	DC	Full			
CH14	ON	x 1	OFF	0.00dV		x 1.11	1.00	acCL	Full			
CH15	ON	10.00E+00	OFF	0.00dV	10.0000E+100	x 1		Ue10	Logic5			
CH16	ON	20%	OFF	0.00dV	0.00%	x 1		Uetu	Logic5			

All  
V/Div, Range  
Offset etc.

Lin-Scale,  
Unit etc.

DSP CH

Copy to  
Same Module

Strain  
Balance

#### • Lin-Scale, Unit etc.

Setup												
No.	Invert	Linear	AX+B:A	AX+B:B	Unit Label							
	Bias	Scale	P1-P2 P1:X	P1-P2 P1:Y	P1-P2 P2:X	P1-P2 P2:Y						
CH1	ON	AX+B	1.0000E+00	0.0000E+00								CH1
CH2	ON	P1-P2	0.0000E+00	0.0000E+00	1.0000E+00	1.0000E+00						CH2
CH3	OFF	OFF										CH3
CH4	OFF	OFF										CH4
CH5	OFF	OFF										CH5
CH6	OFF	OFF										CH6
CH7	OFF	OFF										CH7
CH8	OFF	OFF										CH8
CH9	OFF	OFF										CH9
CH10	OFF	OFF										CH10
CH11	ON	Shift	0.0000E+00	0.0000E+00	1.0000E+00	1.0000E+00						CH11
CH12	ON	OFF										CH12
CH13	OFF	OFF										CH13
CH14	OFF	OFF										CH14
CH15	ON	AX+B	1.0000E+00	0.0000E+00								CH15
CH16	OFF	P1-P2	0.0000E+00	0.0000E+00	1.0000E+00	1.0000E+00						CH16

All  
V/Div, Range  
Offset etc.

Lin-Scale,  
Unit etc.

DSP CH

Copy to  
Same Module

Strain  
Balance

#### • DSP CH

Setup												
No.	Disp	V/div	Var.	Position	Upper	V200m	Unit Label					
				Lower								
A11	OFF		OFF									
BSP1	OFF	10.00E+00	OFF	0.00dV		x 1						BSP1
BSP2	OFF	10.00E+00	OFF	0.00dV		x 1						BSP2
BSP3	OFF	10.00E+00	OFF	0.00dV		x 1						BSP3
BSP4	OFF	10.00E+00	OFF	0.00dV		x 1						BSP4
BSP5	OFF	10.00E+00	OFF	0.00dV		x 1						BSP5
BSP6	OFF	10.00E+00	OFF	0.00dV		x 1						BSP6
Operation Src1 Src2 Exp F-Type F-Band A Cutoff B PassBand C CenterFreq												
BSP1	Fit(S1)	CH1	CH2	1TR	High-Pass	10.0z						
BSP2	S1 + S2	CH1	CH2									
BSP3	S1 + S2	CH1	CH2									
BSP4	S1 + S2	CH1	CH2									
BSP5	S1 + S2	CH1	CH2									
BSP6	S1 + S2	CH1	CH2									

All  
V/Div, Range  
Offset etc.

Lin-Scale,  
Unit etc.

DSP CH

Copy to  
Same Module

**Copying to the Same Type of Modules**

2. Press the **Copy to Same Module** soft key. The Copy From Ch screen appears.
3. Turn the **jog shuttle** to select Copy From Ch and press **SELECT**.
4. Use the **jog shuttle** and **SELECT** to select the copy source channel.
5. Turn the **jog shuttle** to select Exec and press **SELECT**. All of the settings are copied to all the channels of the same type of modules as the copy source.

**Note**

Waveform colors and labels are not copied.

No.	Disp	U/div	Var.	Position	Offset	UZoom	Probe	Cpl	Band
		Range	Unit	Lower	Upper	RJC	Excit	GF	
All1	ON	Gain	OFF		CenterFreq		BurnOut	FvFunc	FvInput
CH1	ON	500	OFF	0.00div	250.0 U	x 1	10:1	DC	Fu11
CH2	OFF	500	OFF	0.00div	0.0 U	x 1	10:1	DC	Fu11
CH3	OFF	500	OFF	0.00div	0.00 U	x 1	10:1	DC	Fu11
CH4	OFF	500	OFF	0.00div	0.00 U	x 1	1:1	DC	Fu11
CH5	OFF	50	OFF	0.00div	0.000 U	x 1	1:1	DC	
CH6	OFF	50	OFF	0.00div	0.000 U	x 1	1:1	DC	
CH7	ON	K		-200.0c	1300.0c	ON	BoutOFF	TC	Fu11
CH8	ON	50	OFF	0.00div	0.000 U	x 1			
CH9	ON	10mU/U	NU/U	-10.0000mU/U	10.0000mU/U		20	2.00	Fu11
CH10	ON	20000uSTR	STR	-20000uSTR	20000uSTR		20	2.00	Fu11
CH11	ON	10mU/U	NU/U	-10.0000mU/U	10.0000mU/U		20	2.00	Fu11
CH12	ON	20000uSTR	STR	-20000uSTR	20000uSTR		20	2.00	Fu11
CH13	ON	5mU	OFF	0.00div	0.000mU	x 1	1:1	DC	Fu11
CH14	ON	x 1	OFF	0.00div	0.000mU	x 1.11	1.00	ACCL	Fu11
CH15	ON	10.00E+00	OFF	0.00div	10.00001E+100	x 1	Ue10	Loq1C5	
CH16	ON	20z	OFF	0.00div	0.00z	x 1	Buty	Loq1C5	

**Turning ON/OFF the All the Channels**

2. Use the **jog shuttle** or arrow keys to move to the Disp box for All and press **SELECT**. You can turn ON/OFF all the channels simultaneously.

Turn ON/OFF all the channels(CH1 to CH16) simultaneously.

No.	Disp	U/div	Var.	Position	Offset	UZoom	Probe	Cpl	Band
		Range	Unit	Lower	Upper	RJC	Excit	GF	
All1	ON	Gain	OFF		CenterFreq		BurnOut	FvFunc	FvInput
CH1	ON	500	OFF	0.00div	250.0 U	x 1	10:1	DC	Fu11
CH2	OFF	500	OFF	0.00div	0.0 U	x 1	10:1	DC	Fu11
CH3	OFF	500	OFF	0.00div	0.00 U	x 1	10:1	DC	Fu11
CH4	OFF	500	OFF	0.00div	0.00 U	x 1	10:1	DC	Fu11
CH5	OFF	50	OFF	0.00div	0.000 U	x 1	1:1	DC	
CH6	OFF	50	OFF	0.00div	0.000 U	x 1	1:1	DC	
CH7	ON	K		-200.0c	1300.0c	ON	BoutOFF	TC	Fu11
CH8	ON	50	OFF	0.00div	0.000 U	x 1			
CH9	ON	10mU/U	NU/U	-10.0000mU/U	10.0000mU/U		20	2.00	Fu11
CH10	ON	20000uSTR	STR	-20000uSTR	20000uSTR		20	2.00	Fu11
CH11	ON	10mU/U	NU/U	-10.0000mU/U	10.0000mU/U		20	2.00	Fu11
CH12	ON	20000uSTR	STR	-20000uSTR	20000uSTR		20	2.00	Fu11
CH13	ON	5mU	OFF	0.00div	0.000mU	x 1	1:1	DC	Fu11
CH14	ON	x 1	OFF	0.00div	0.000mU	x 1.11	1.00	ACCL	Fu11
CH15	ON	10.00E+00	OFF	0.00div	10.00001E+100	x 1	Ue10	Loq1C5	
CH16	ON	20z	OFF	0.00div	0.00z	x 1	Buty	Loq1C5	

Turn ON/OFF all the DSP channels(DSP1 to DSP6) simultaneously.

No.	Disp	U/div	Var.	Position	Upper	UZoom	Unit Label
		Range	Unit	Lower			
All1	OFF	Gain	OFF				
DSP1	OFF	10.00E+00	OFF	0.00div		x 1	DSP1
DSP2	OFF	10.00E+00	OFF	0.00div		x 1	DSP2
DSP3	OFF	10.00E+00	OFF	0.00div		x 1	DSP3
DSP4	OFF	10.00E+00	OFF	0.00div		x 1	DSP4
DSP5	OFF	10.00E+00	OFF	0.00div		x 1	DSP5
DSP6	OFF	10.00E+00	OFF	0.00div		x 1	DSP6

Operation	Src1	Src2	Exp	F-Band	a	B	C
			F-Type		CutOff	PassBand	CenterFreq
DSP1	Fit(S1)	CH1	IIR	High-Pass	10.0z		
DSP2	S1 * S2	CH1	CH2				
DSP3	S1 * S2	CH1	CH2				
DSP4	S1 * S2	CH1	CH2				
DSP5	S1 * S2	CH1	CH2				
DSP6	S1 * S2	CH1	CH2				

## 5.13 Displaying the All Channel Setup Menu

### Turning Variable ON/OFF on All Channels

- Use the **jog shuttle** or arrow keys to move to the All box of Var. and press **SELECT**. You can turn ON/OFF Variable (zooming vertically according to the upper and lower limits of the display range) of all channels (except those in which strain modules installed) simultaneously.

Turn ON/OFF all the channels(CH1 to CH16) simultaneously.

Setup												
No.	Disp	U/div	Var.	Position	Offset	UZoom	Probe	Cpl	Band			
		Range	Unit	Lower	Upper	RJC	Excit	GF				
		Gain	OFF	CenterFreq								
CH1	ON	500	OFF	0.00dV	0.0 U	x 1	10:1	DC	Fu11			
CH2	ON	500	OFF	0.00dV	0.0 U	x 1	10:1	DC	Fu11			
CH3	ON	50	OFF	0.00dV	0.000 U	x 1	1:1	DC	Fu11			
CH4	ON	50	OFF	0.00dV	0.000 U	x 1	1:1	DC	Fu11			
CH5	ON	500	OFF	0.00dV	0.00 U	x 1	10:1	DC	Fu11			
CH6	ON	500	OFF	0.00dV	0.00 U	x 1	10:1	DC	Fu11			
CH7	ON	50	OFF	0.00dV	0.000 U	x 1		DC	Fu11			
CH8	ON	50	OFF	0.00dV	0.000 U	x 1		DC	Fu11			
CH9	ON	20000uSTR	OFF	-20000uSTR	20000uSTR		20	2.00	Fu11			
CH10	ON	20000uSTR	OFF	-20000uSTR	20000uSTR		20	2.00	Fu11			
CH11	ON	20000uSTR	OFF	-20000uSTR	20000uSTR		20	2.00	Fu11			
CH12	ON	20000uSTR	OFF	-20000uSTR	20000uSTR		20	2.00	Fu11			
CH13	ON	1kHz	OFF	0.00dV	0.0 Hz			Freq	User			
CH14	ON	1kHz	OFF	0.00dV	0.0 Hz			Freq	User			
CH15	ON	50	OFF	0.00dV	0.000 U	x 1		DC	Fu11			
CH16	ON	50	OFF	0.00dV	0.000 U	x 1		DC	Fu11			

Turn ON/OFF all the DSP channels(DSP1 to DSP6) simultaneously.

Setup												
No.	Disp	U/div	Var.	Position	Upper	UZoom	Unit Label					
		Range	Unit	Lower								
A11	OFF		OFF									
DSP1	OFF	10.00E+00	OFF	0.00dV		x 1						DSP1
DSP2	OFF	10.00E+00	OFF	0.00dV		x 1						DSP2
DSP3	OFF	10.00E+00	OFF	0.00dV		x 1						DSP3
DSP4	OFF	10.00E+00	OFF	0.00dV		x 1						DSP4
DSP5	OFF	10.00E+00	OFF	0.00dV		x 1						DSP5
DSP6	OFF	10.00E+00	OFF	0.00dV		x 1						DSP6
		Operation	Src1	Src2	Exp	F-Type	F-Band	A	B	C		
								Cutoff	PassBand	CenterFreq		
DSP1		S1 + S2	CH1	CH2								
DSP2		S1 + S2	CH1	CH2								
DSP3		S1 + S2	CH1	CH2								
DSP4		S1 + S2	CH1	CH2								
DSP5		S1 + S2	CH1	CH2								
DSP6		S1 + S2	CH1	CH2								

### Note

The range unit of the strain module is displayed in the Var. Unit box of the channel in which a strain module is installed. The range unit does not change even if Var. All is turned ON/OFF.

### Executing the Balancing of the Strain Module

- Press the **Strain Balance** soft key. The Balance screen appears.
- Use the **jog shuttle** and **SELECT** to set the channel on which to execute balancing.
- Turn the **jog shuttle** to select Exec and press **SELECT**. Balancing is executed.

The image shows the 'Setup' menu with the 'Balance' screen overlaid. The 'Balance' screen has a list of channels (CH1-CH16) with checkboxes. The 'Strain Balance' soft key is highlighted at the bottom of the Balance screen. The 'Setup' menu shows the 'Var.' column with 'OFF' for all channels, and the 'U/div' column with various units like '500', '50', '10mV', '20000uSTR', '10mV', '50', '10.00E+00', '20%', and '0.00dV'.

### Explanation

You can display the setup menu of all the channels over the entire screen to set the channels. The parameters that you can set are the setup parameters of the channel key and waveform color.



# 5.14 Setting the Time Base (Internal Clock/External Clock)

<For a description of this function, refer to page 2-11.>

## Procedure

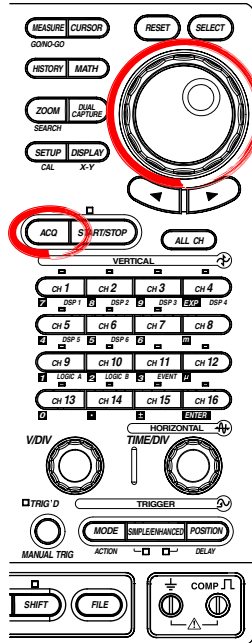

### Selecting the Time Base

1. Press **ACQ**.
2. Press the **Time Base** soft key and then select Int or Ext.  
If you select Ext, the Pulse/Rotate setup menu appears.

### Setting Pulse/Rotate (When Time Base Is Set to Ext)

3. Press the **Pulse/Rotate** soft key.
4. Turn the **jog shuttle** to set the number of pulses (of the external clock signal) for the pulse/rotate function. Pressing **RESET** resets the value to 1.

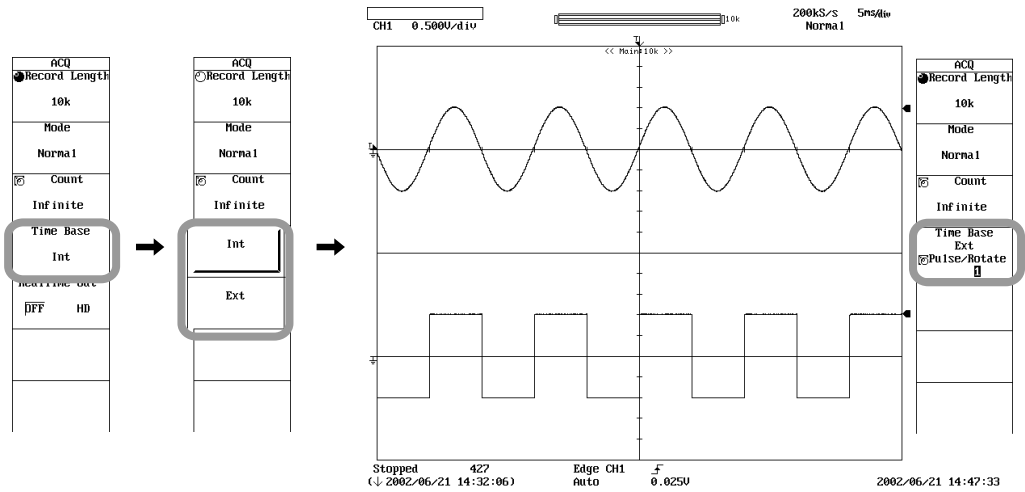

## 5.14 Setting the Time Base (Internal Clock/External Clock)

### Explanation

#### Selecting the Time Base

Select from the following:

Int: Internal clock signal (TIME/DIV knob is valid).

Ext: Clock signal applied to the external clock input terminal (TIME/DIV knob is invalid).

#### When Selecting Ext

Apply a clock signal of the following specifications to the TRIG OUT/EXT CLK IN terminal (shared with the trigger output terminal) on the left side panel.



Item	Specifications
Connector type	RCA jack
Frequency range	See Note below
Input level	TTL (0 to 5 V)
Valid edge	Rising edge
Minimum pulse width	400 ns or more for high and low levels
External clock frequency range	1 MHz maximum.
Rise/Fall time of the clock	2 $\mu$ s or less

#### Note

- The upper limit frequency of the external clock is as follows:
 

701250/701251/701255:	1 MHz
701260/701270/701271/701275:	100 kHz
701280:	25 kHz
701261/701262:	When measuring voltage: 100 kHz When measuring temperature: 500 Hz
701265:	500 Hz
DSP channels:	100 kHz
- If the external clock frequency exceeds the upper limit frequency of the module, sampling is executed at the upper limit frequency.

#### External Clock Input Circuit Diagram and Timing Chart

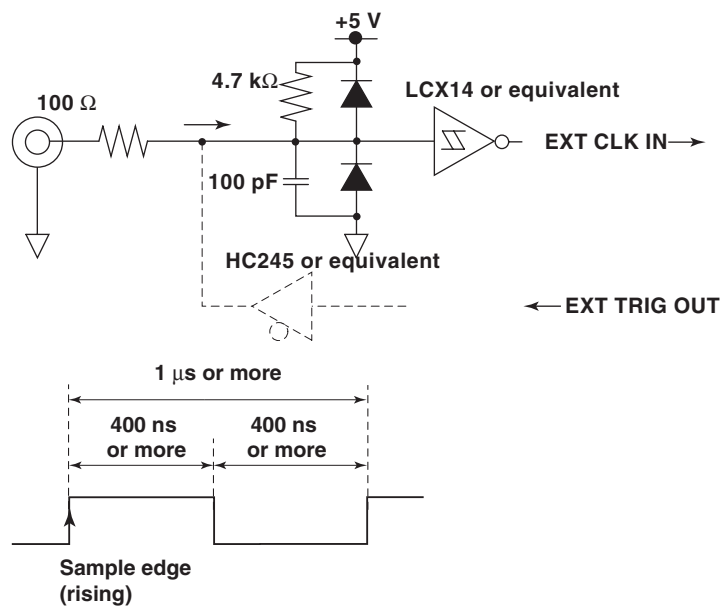



### CAUTION

Applying a voltage exceeding the maximum allowable input voltage to the TRIG OUT/EXT CLK IN terminal may damage the input section.

#### Setting Pulse/Rotate

You can specify the number of pulses of the external signal that is to correspond to one mechanical rotation (one cycle).

Range of the number of pulses: 1 to 24000

#### Notes When Sampling Using the External Clock Signal

- You cannot set the acquisition mode to envelope or box average.
- You cannot display waveforms in roll mode.
- No function is provided for frequency-dividing the clock signal.
- Since the time axis setting cannot be changed, change the record length setting or zoom in on the time axis if you want to change the display range of the time axis.
- The time measured by the cursor measurement or automated measurement of waveform parameters is expressed in terms of the number of pulses of the clock signal. No unit is displayed.
- Realtime recording to the internal hard disk cannot be selected.
- Saving data using the dual capture function is not possible.
- The following trigger settings are invalid.
  - Trigger delay
  - Hold off
  - B > Time, B < Time, and B Time Out trigger
  - Period trigger

#### Maximum Sample Rate of Each Module

If the sample rate of the DL750/DL750P is set higher than the maximum sample rate of the module, the data is updated only at the maximum sample rate of the module. Consequently, all of the data within the data update interval of the module are the same data. The maximum sample rate of each module is as follows:

##### Maximum Sample Rate of Each Module

Module	During Internal Clock	During External Clock
701250/701255:	10 MHz	1 MHz
701251:	1 MHz	1 MHz
701260/701270/701271/ 701275/:	100 kHz	100 kHz
701261/701262 (measuring voltage): (measuring temperature):	100 kHz 500 Hz	100 kHz 500Hz
701280:	25 kHz	25 kHz
701265:	500 Hz	500 Hz
DSP channel:	100 kHz	100 kHz

## 5.15 Observing RMS Values

<For a description of this function, refer to page 2-12.>

This section describes the procedure when measuring the RMS value on the 701260 (HV(with RMS)) .

### Procedure

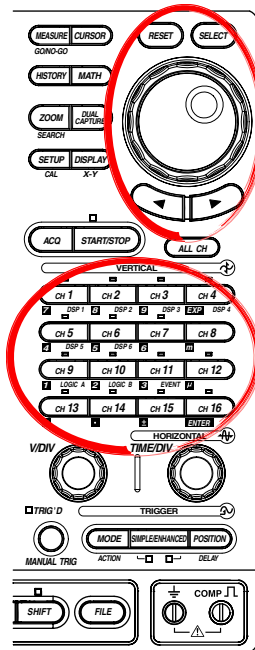

1. Press a key from **CH1** to **CH16** keys to select the desired channel (select a channel with the 701260 (HV (with RMS)) installed).
2. Press the **Coupling** soft key followed by the **DC-RMS** or **AC-RMS** soft key.

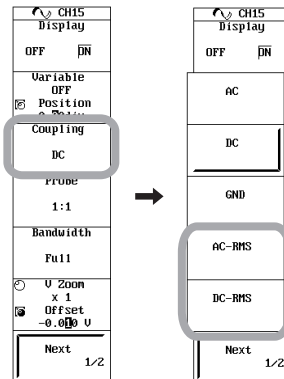

### Explanation

#### Selecting the Input Coupling

In addition to the same input coupling selections that are available on other voltage modules, you can also select the waveform observation mode (Coupling: AC, DC, or GND) which directly displays the waveform of the input signal and the RMS observation mode (Coupling: AC-RMS or DC-RMS) which displays the rms values of the input signal. For details on the rms measurement, see page 2-12. For details on the input coupling circuit of AC-RMS/DC-RMS, see page 2-8.

#### Notes When Observing Rms Values

If an AC component that is less than 40 Hz is acquired in the RMS observation mode, ripples are produced as a result of the RMS conversion circuit characteristics and correct rms values cannot be displayed. DC signals are correctly observed.

# 5.16 Setting the Temperature Measurement

<For a description of this function, refer to page 2-13.>

## Procedure

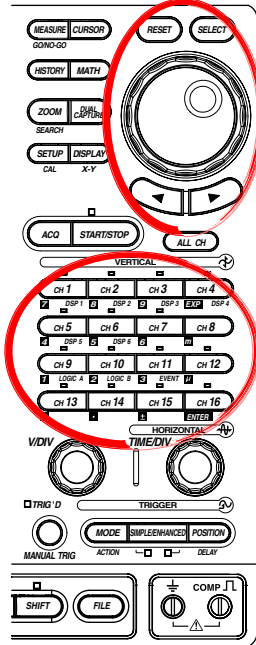

1. Press a key from **CH1** to **CH16** keys to select the desired channel (select a channel with the 701261 (UNIVERSAL)/701262 (UNIVERSAL (AAF))/701265 (TEMP/HPV) installed).
2. Press the **Coupling** soft key followed by the **TC** soft key.

### Selecting the Thermocouple Type

3. Press the **Type** soft key to select the thermocouple from K to Au7Fe.

### Setting the Display Range

4. Press the **Upper** soft key.
5. Turn the **jog shuttle** to set the upper limit.
6. Likewise, set Lower.

### Selecting the Temperature Unit

7. Press the **Next 1/2** soft key.
8. Press the **Unit** soft key to select °C, K, or °F.

### Setting the RJC

9. Press the **RJC** soft key to select OFF or ON.

### Setting Burnout

10. Press the **Burn Out** soft key to select OFF or ON.

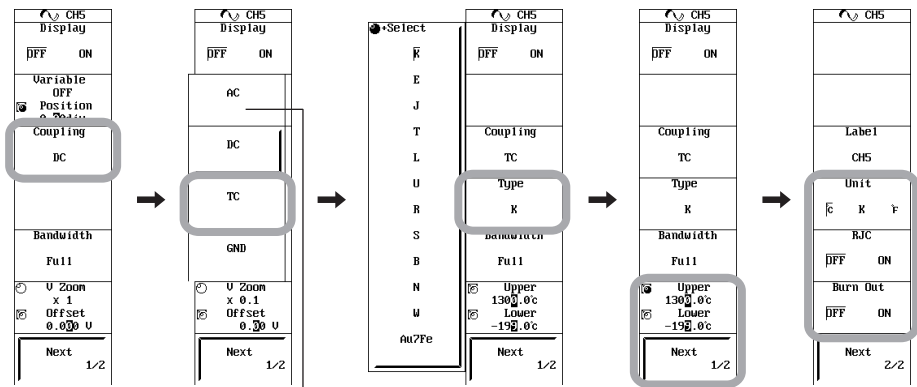

AC is not available on the 701265.

## 5.16 Setting the Temperature Measurement

---

### Explanation

#### Thermocouple Type

Select the type to match the thermocouple that you are using.

Select the thermocouple type from the following.

When the input terminal is open, the displayed value is set to a value less than or equal to the lower limit of the measurement range.

Type	Measurement Range
K	-200 to 1300°C
E	-200 to 800°C
J	-200 to 1100°C
T	-200 to 400°C
L	-200 to 900°C
U	-200 to 400°C
R	0 to 1700°C
S	0 to 1700°C
B	400 to 1800°C
N	0 to 1300°C
W	0 to 2300°C
Au7Fe	0 to 300 K

#### Temperature Unit

Select the temperature unit from °C, K, or °F. The default setting is °C.

#### Setting the Display Range

To display the measured waveform, the upper and lower limits need to be set according to the input.

- **Selectable Range**
    - -5432 to 5432°C (resolution: 0.1°C)
    - -5432 to 5432 K (resolution: 0.1 K)
    - -5432 to 5432°F (resolution: 0.1°F)
- The minimum span is 2 °C (or 2 K).

#### Setting the RJC

The DL750/DL750P normally performs reference junction compensation with the built-in RJC circuit when measuring temperature with the thermocouple. When checking the temperature measurement value, or when using an external reference junction (0°C), the internal reference junction compensation needs to be disabled.

The DL750/DL750P allows you to select whether to use the internal reference junction compensation.

Normally, this is set to ON.

#### Note

---

If a voltage corresponding to a certain temperature  $t$  is applied at the input with the RJC turned OFF and the measured temperature is not correct, the instrument may be damaged. Contact your nearest YOKOGAWA dealer.

---

#### Burnout Setting

If the thermocouple measurement input detects a burnout, the measured value is fixed to the upper limit of the measurement range of each thermocouple. This function is used to accurately detect a burnout in the thermocouple. By default, this setting is turned OFF (do not detect burnouts).

# 5.17 Setting the Strain Measurement

<For a description of this function, refer to page 2-14.>

## Procedure

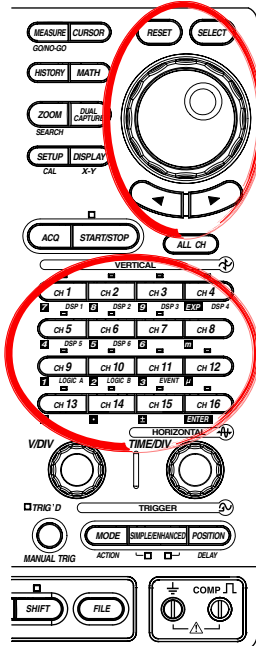

1. Press a key from **CH1** to **CH16** keys to select the desired channel (select a channel with the Strain Module (701270 (STRAIN\_NDIS) or 701271 (STRAIN\_DSUB)) installed).

### Selecting the Measurement Range

2. Press the **Range Unit** soft key, and then press the **μSTR** (the unit of strain) or **mV/V** (the unit of the output value of the strain gauge transducer) soft key.

### Note

Be sure to execute balancing when you change the measurement range.

### When μSTR Is Selected

3. Use the **jog shuttle** to select the Range from 500 μSTR to 20000 μSTR.

### When mV/V Is Selected

3. Use the **jog shuttle** to select the Range from 0.25 mV/V to 10 mV/V.

### Note

If the range unit is set to mV/V, a numeric value is displayed at the right side of the range display. This value is the maximum input at the current bridge voltage converted to volts. It indicates the maximum input voltage at the selected range.



### Setting the Display Range

4. Press the **Upper/Lower** soft key to set the jog shuttle control to Upper.
5. Turn the **jog shuttle** to set the upper limit.
6. Likewise, set Lower.

### Note

Pressing RESET sets the upper and lower limits to the maximum and minimum values of the measurement range.

#### When Range Unit is μSTR

#### When Range Unit is mV/V

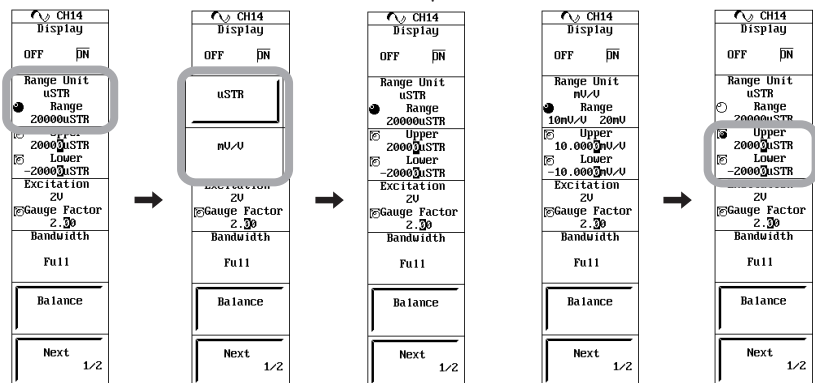

## 5.17 Setting the Strain Measurement

### Setting the Gauge Factor

7. Press the **Excitation/Gauge Factor** soft key to set the jog shuttle control to Gauge Factor.
8. Use the **jog shuttle** to set the gauge factor in the range of 1.90 to 2.20.

### Selecting the Bridge Voltage

9. Press the **Excitation/Gauge Factor** soft key.
10. Press the **2 V**, **5 V**, or **10 V** soft key to select the Excitation (bridge voltage).

### Note

- The bridge voltage can be set to 5 V or 10 V only when the following conditions are met.
  - When the bridge resistance is 350  $\Omega$  or more
  - Strain gauge transducer supports the bridge voltage of 5 V or 10 V.
- Be sure to execute balancing when you change the bridge voltage.

### Execute balancing

11. Press the **Balance** soft key. Balancing is executed.

### Note

Perform balancing by connecting a bridge box or strain gauge transducer and without applying a load to the strain gauge.

### Setting the Bandwidth, Linear Scaling, and Waveform Label

For the setup procedure of bandwidth, linear scale, and waveform label, see section 5.7, 5.11, and 8.10, respectively.

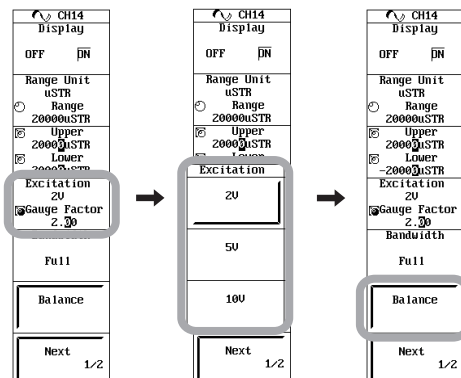



**Executing Shunt Calibration (only on the 701271(STRAIN\_DSUB))**

To execute shunt calibration, the strain corresponding to the shunt resistor to be used must be calculated in advance. For the calculation procedure, see appendices 10 and 11.

Be sure to execute balancing before executing shunt calibration.

12. Press the **Next 1/2** soft key.
  13. Press the **Linear Scale** soft key. A Linear Scale setup dialog box appears.
  14. Use **SELECT**, **jog shuttle**, and **SELECT** to set Mode to Shunt.
- **Reading the Connected Shunt Resistance and Calibrating**
    15. Use **SELECT** and the **jog shuttle** to set a strain corresponding to the calculated shunt resistance in P2:Y.
    16. As necessary, enter the Unit according to the procedures given in section 4.2.
    17. Use the **jog shuttle** and **SELECT** to select Exec. The current input value is reflected in P2:X.

**Note**

- In a normal shunt calibration, set only P2:Y (P1:Y is 0).
- Scale the strain value using a shunt resistor. P1:X is the input value when a shunt resistor is not connected. P1:Y is the strain value corresponding to P1:X. P2:X is the input value when a shunt resistor is connected. P2:Y is the strain value corresponding to the shunt resistance. The line connecting points P1 and P2 is used to perform scaling.
- When Shunt Cal Exec is executed, the relay circuit for shunt calibration built into the strain module is turned ON/OFF to automatically set P1:X and P2:X to the input value when the shunt resistor is connected and the input value when the shunt resistor is not connected, respectively.
- If you change P1:X, P1:Y, P2:X, or P2:Y, the linear scaling setting is also changed.
- Executing Shunt Cal Exec changes P1:X and P2:X to the current input values.

**Inverting the Waveforms**

For details on the inverted display, see section 5.12.

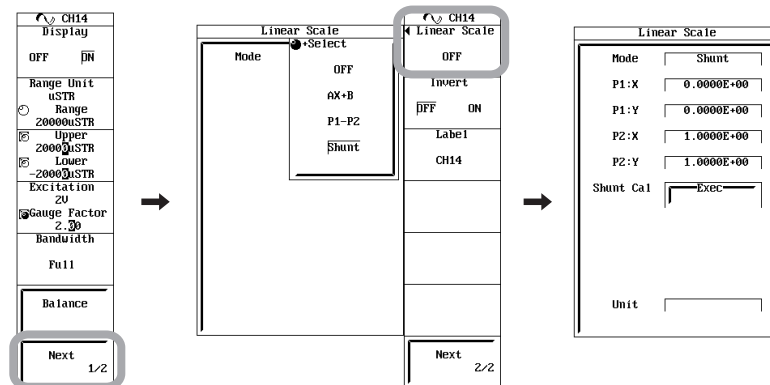

### Explanation

#### Select the Range Unit

The unit can be changed between “the strain unit ( $\times 10^{-6}$  strain):  $\mu\text{STR}$ ” and “the output unit of the strain gauge transducer:  $\text{mV/V}$ .” The default value is  $\mu\text{STR}$ . The following equation is used to derive  $\text{mV/V}$ .

$$\text{mV/V} = 0.5 \times (\mu\text{STR}/1000)$$

#### Selecting the Range

Select from the following:

- **When  $\mu\text{STR}$  Is Selected**

500  $\mu\text{STR}$ , 1000  $\mu\text{STR}$ , 2000  $\mu\text{STR}$ , 5000  $\mu\text{STR}$ , 10000  $\mu\text{STR}$ , and 20000  $\mu\text{STR}$

For a description of the measurement range, see chapter 19.12, “Module Specifications.”

- **When  $\text{mV/V}$  Is Selected**

0.25 $\text{mV/V}$ , 0.5 $\text{mV/V}$ , 1 $\text{mV/V}$ , 2.5 $\text{mV/V}$ , 5 $\text{mV/V}$ , and 10 $\text{mV/V}$

For a description of the measurement range, see chapter 19.12, “Module Specifications.”

The value that is indicated at the right side of the range display is the maximum input at the current bridge voltage converted to volts. It indicates the maximum input voltage at the selected range.

#### Setting the Display Range: Upper/Lower

You can change the upper and lower limits of the display range according to the input for easier viewing of the measured waveforms.

Selectable range:  $-3.0000\text{E}+04$  to  $+3.0000\text{E}+04$  (when set to  $\mu\text{STR}$ )

$-1.5000\text{E}+01$  to  $+1.5000\text{E}+01$  (when set to  $\text{mV/V}$ )

Be sure the upper limit value (Upper) is greater than the lower limit value (Lower).

#### Selecting the Bridge Voltage: Excitation

You can select the voltage to be applied to the bridge head.

- 2 V: When the bridge head resistance (bridge resistance) is 120  $\Omega$  to 1000  $\Omega$
- 5 V<sup>1</sup>: When the bridge resistance is 350  $\Omega$  to 1000  $\Omega$
- 10 V<sup>1</sup>: When the bridge resistance is 350  $\Omega$  to 1000  $\Omega$

The bridge voltage cannot be changed while waveform acquisition is in progress.

1. The bridge voltage can be set to 5 V or 10 V only when the following conditions are met.
  - The bridge resistance is 350  $\Omega$  or more
  - Strain gauge transducer supports the bridge voltage of 5 V or 10 V.

**Setting the Gauge Factor**

You can set the gauge factor of the strain gauge.

Selectable range: 1.90 to 2.20 (the resolution is 0.01)

The gauge factor is a unique constant defined for the strain gauge. It is usually described in the manual for the strain gauge. The gauge factor cannot be changed while waveform acquisition is in progress.

**Gauge Factor (K) when mV/V Is Selected**

You can set the gauge factor to an arbitrary value on the DL750/DL750P. However, if there is no specifications on the strain gauge transducer, set the gauge factor to 2.00. If the gauge factor is not 2.00, e is derived within the DL750/DL750P using the following equation.

$$e = (4/K) \times (V/E)$$

e: Measured value of the strain gauge transducer [mV/V]  
 V: Voltage measured on the bridge [V]  
 E: Voltage applied to the bridge [V]  
 K: Gauge factor

**Setting the Bandwidth**

See section 5.7, "Setting the Bandwidth."

**Execute Balancing**

The unbalanced portion of the bridge resistance is automatically compensated. The execution of balancing takes a few seconds.

Balance range:  $\pm 10000 \mu\text{STR}$  (when set to  $\mu\text{STR}$ )  
 $\pm 5\text{mV/V}$  (when set to mV/V)

**Inverting the Waveforms**

See section 5.12, "Inverting Waveforms."

**Precautions to Be Taken When Making Strain Measurements**

- Be sure to execute balancing when making strain measurements.
- Select a bridge voltage of 5 V or 10 V when the bridge resistance is 350  $\Omega$  or more. If a bridge voltage of 5 V or 10 V is applied when the bridge resistance is less than 350  $\Omega$ , correct measurements will not be made.
- When using a strain gauge transducer, use a bridge voltage in the recommended voltage range of the transducer.
- Correction cannot be executed if a strain gauge bridge (bridge head) or a strain gauge transducer is not connected to the channel on which balancing is to be executed.
- If balancing fails on any of the specified channels, an error message and information on the failed channel is displayed.
- If the power is turned ON, a new strain gauge is connected, or the measurement range, bridge voltage, or gauge factor is changed, balancing must be performed again before making measurements.

The scale value indicates "imbalance" immediately after power-up or when the range is changed. In such case, execute balancing.

- When you switch the unit, the unit of all related parameters of the channel is switched accordingly (upper and lower limits, trigger level, measured values of automated measurement parameters, cursor measurement values, etc.).

## 5.17 Setting the Strain Measurement

### Shunt Calibration (Only on the 701271(STRAIN\_DSUB))

The 701271 Strain Module (STRAIN\_DSUB) supports shunt calibration.

Shunt calibration is used to correct the gain of strain measurements by inserting a known resistance (shunt calibration resistance (shunt resistance)) in parallel with the strain gauge. It is a type of scaling. The Strain Module (701271(STRAIN\_DSUB)) supports shunt calibration and contains a built-in relay circuit for shunt calibration.

To execute shunt calibration, a bridge head that supports shunt calibration (701957/701958) is needed.

#### • When correcting the gain on the negative side (normal)

Shunt calibration relay circuit (Built into the strain module. Turns ON/OFF automatically when shunt calibration is executed.)

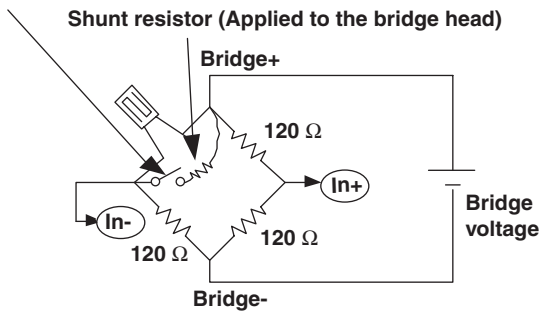

#### • When correcting the gain on the positive side

Shunt calibration relay circuit (Built into the strain module. Turns ON/OFF automatically when shunt calibration is executed.)

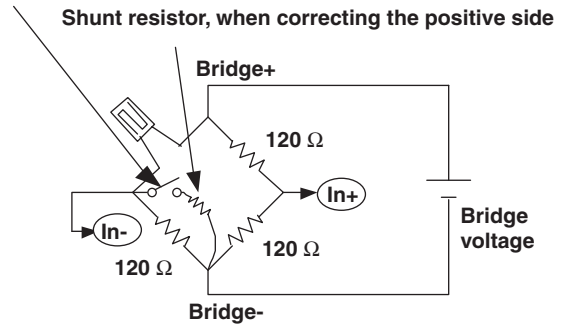

In addition to the normal shunt calibration (when the shunt calibration relay circuit is ON), the DL750/DL750P allows the setting of a zero point when the relay circuit is OFF. This function is useful when the strain value is not 0 after the execution of balancing.

P1:X: If (Shunt Cal) Exec is executed, the input value when the relay circuit is OFF is applied.

P1:Y: Set the value (usually 0) when the relay circuit is OFF.

P2:X: If (Shunt Cal) Exec is executed when the relay circuit is ON, the input value when the relay circuit is ON is applied.

P2:Y: Set the strain value corresponding to the shunt resistance when the relay circuit is ON.

#### • Shunt calibration

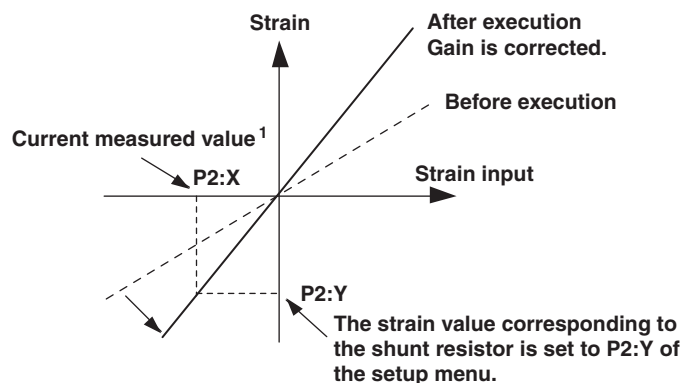

1. Automatically obtained when shunt calibration is executed.

For details on shunt calibration, see appendix 11.

**Note**

- When executing shunt calibration, select an appropriate range so that the measured values do not exceed the range when the shunt calibration relay circuit is ON. The DL750/DL750P attempts shunt calibration within the current specified range.
  - If shunt calibration fails (the measured value exceeds the range, for example), an error message is displayed. In such case, change the range and execute shunt calibration again.
-

## 5.18 Setting the Acceleration Measurement

<For a description of this function, refer to page 2-15.>

### CAUTION

Before connecting the acceleration sensor, check that the bias current to the sensor is OFF (see step 8 below). Otherwise, damage to the internal circuitry of the acceleration sensors may result.

### Procedure

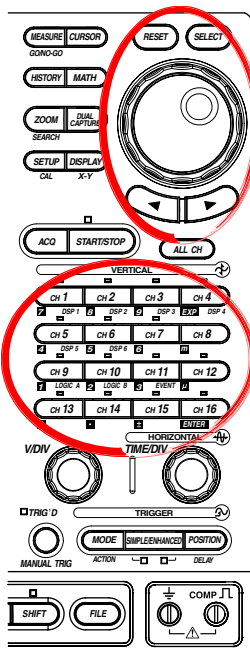

1. Press one of the keys from **CH1** to **CH16** to select the desired channel (select a channel with the 701275(ACCL/VOLT) installed).
2. Press the **Coupling** soft key followed by the **ACCL** soft key.

### Setting the Gain

3. Press the **Gain** soft key and select a value in the range of  $\times 0.1$  to  $\times 100$ .

### Setting the Sensitivity

4. Press the **Next 1/2** soft key.
5. Press the **Sensitivity** soft key.
6. Turn the **jog shuttle** and set the sensitivity of the acceleration sensor in the range of 0.10 mV/Unit to 2000.00 mV/Unit.

### Setting the Unit

The default value is  $\text{m/s}^2$ . Change the unit as necessary.

7. Press the **Unit** soft key to display a software keyboard, and enter the unit according to the procedure given in section 4.2.

### Connecting the Acceleration Sensor

8. Press the **Bias** soft key to select OFF.
9. Connect the acceleration sensor according to the procedures given in section 3.12.

### Setting the Bias Current Supply

10. Press the **Bias** soft key to select ON.

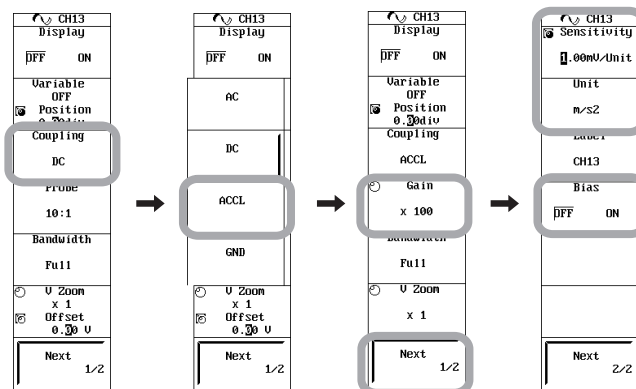

**Setting the Bandwidth Limit and Waveform Label**

For the setup procedure of the bandwidth limit, see section 5.7. For the setup procedure of the waveform label, see section 8.10.

**Explanation****Setting the Gain**

Set the ratio of the output signal with respect to the input signal in the range of  $\times 0.1$  to  $\times 100$ .

The default value is  $\times 1$ .

**Setting the Sensitivity**

Set the sensitivity of the acceleration sensor in the range of 0.10 mV/Unit to 2000.00 mV/Unit.

**Setting the Unit**

Set the unit of the acceleration to be displayed on the screen using up to 4 characters. The default setting is  $m/s^2$ . Change the unit as necessary.

Up to 8 character strings assigned to the unit are stored. The stored strings can be recalled using the  $\text{↻}$  soft key. In addition, the stored strings can be used on the acceleration modules of other channels. This function is useful when you are assigning the same unit to multiple channels. The stored strings are not cleared even when the power is turned OFF.

**Setting the Bias Current Supply to the Acceleration Sensor**

When Bias is turned ON, a 4-mA bias current is supplied to the acceleration sensor. Do not connect the acceleration sensor with Bias turned ON.

**Setting the Bandwidth Limit**

See section 5.7, "Setting the Bandwidth Limit."

# 5.19 Setting the Frequency (Number of Rotations, Period, Duty Cycle, Power Supply Frequency, Pulse Width, Pulse Integration, and Velocity) Measurement

<For a description of this function, refer to page 2-16.>

## Procedure

1. Press one of the keys from **CH1** to **CH16** to select the desired channel (select a channel with the 701280(FREQ) installed).

### Setting the Input

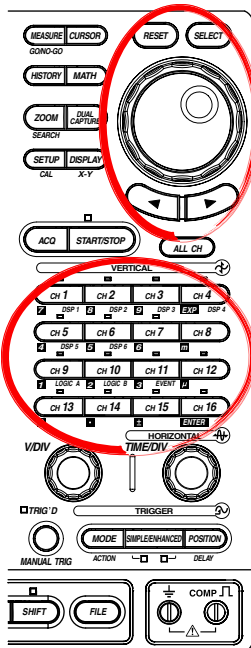

### Setting the Preset

2. Press the **Input Setup** soft key. A setup dialog box opens.
3. Use the  **jog shuttle** and **SELECT** to select Preset according to the type of sensor that is connected to the frequency module. When you select a preset (Logic 5V to EM Pickup), the input is set to a value appropriate for the signal. (Some items need to be manually entered.)  
If you select User (user-defined), all the setup items can be set arbitrarily. For a description of the setup items, see the next page.

### Typical Applications and Signal Examples of Each Preset

Preset	Application and Signal Example
Logic 5V	5-V logic signal, 5-V output sensor, and sensor with TTL output
Logic 3V	3-V logic signal and 3-V output sensor
Logic 12V	12-V driven relay/sequence circuit and 12-V driven sensor
Logic 24V	24-V driven relay/sequence circuit and 24-V driven sensor
ZeroCross	Sensor/Encoder that outputs positive and negative voltages and sensor that outputs sine waves
AC100V	When measuring a supply voltage of 100 VAC using the isolated probe (700929)
AC200V	When measuring a supply voltage of 200 VAC using the isolated probe (700929)
EM Pickup	Power-generating electromagnetic pickup
Pull -up 5V	Open-collector output sensor and contact circuit

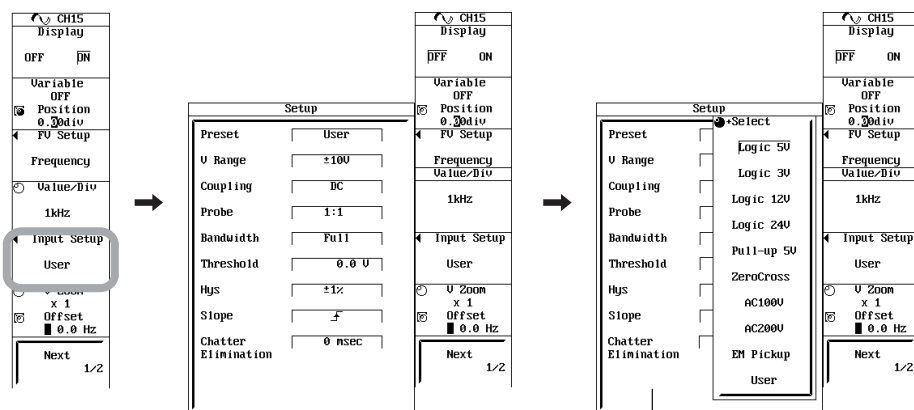

The Pull Up setup menu appears only when you set the preset to Pull-up 5V.



## 5.19 Setting the Frequency (Number of Rotations, Period, Duty Cycle, Power Supply Frequency, Pulse Width, Pulse Integration, and Velocity) Measurement

As necessary, set the items of the preset (Logic 5V to EM Pickup) that you selected in steps 2 and 3. If you select User (user-defined), set all the setup items arbitrarily. All operations are done using the jog shuttle and SELECT.

- When changing the voltage range setting**  
 Select the V Range (voltage range) from  $\pm 1$  V,  $\pm 2$  V,  $\pm 5$  V,  $\pm 10$  V,  $\pm 20$  V, and  $\pm 50$  V. You can change the setting only when you set the preset to ZeroCross or User.
- When changing the input coupling setting**  
 Set the coupling to DC or AC. You can change the setting only when you set the preset to User.
- When changing the probe type setting**  
 Select Probe and set the probe type to 1:1 or 10:1. You can change the setting only when you set the preset to Logic 5V (3V/12V/24V), Pull-up 5V, ZeroCross, or User.
- When changing the bandwidth limit setting**  
 Select the bandwidth limit from 100 Hz, 1 kHz, 10 kHz, 100 kHz, or Full. You can change the setting on all presets. However, if the preset is set to AC100V or AC200V, the bandwidth limit cannot be set to Full.
- When changing the threshold level setting**  
 Set the threshold. You can change the setting only when you set the preset to User.
- When changing the hysteresis setting**  
 Select Hys (hysteresis) from  $\pm 1\%$ ,  $\pm 2.5\%$ , and  $\pm 5\%$ . You can change the setting on all presets.
- When changing the slope setting**  
 Set the slope to  $\uparrow$  (rising) or  $\downarrow$  (falling). You can change the setting only when you set the preset to Logic 5V (3V/12V/24V), Pull-up 5V, or User.
- Setting the Chatter Elimination Function**  
 Select Chatter Elimination and set the chatter elimination time in the range of 0 ms to 1000 ms. You can change the setting on all presets.
- Setting the pull-up**  
 Set Pull Up to ON or OFF if you set the preset to Pull-up 5V.

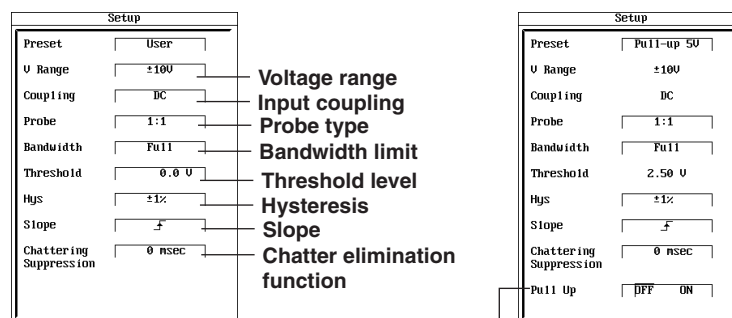

The Pull Up setup menu appears only when you set the preset to Pull-up 5V.

## When Measuring the Frequency

### Setting the Measurement Item

4. Press the **FV Setup** soft key. A setup dialog box opens.
5. Use the **jog shuttle** and **SELECT** to set Function to Frequency.

### Setting Value/Div

6. Turn the V/DIV knob to set the Value/Div value. You can also set Value/Div by pressing the **Value/Div** soft key and turning the **jog shuttle**.

### Note

The unit for Value/Div and offset are synchronized to the unit of the measurement mode selected in steps 4 and 5. For the procedure of setting the offset value, see section 5.10.

Carry out steps 7 to 12 below as necessary.

### Setting the Smoothing Filter

7. To enable the smoothing filter, use the **jog shuttle** and **SELECT** to set Filter to Smoothing.
8. Use the **jog shuttle** and **SELECT** to set the moving average order of smoothing in the range of 0.0 to 1000.0 ms.

### Setting the Pulse Average

9. To enable pulse average, use the **jog shuttle** and **SELECT** to select Pulse Average.
10. Use the **jog shuttle** and **SELECT** to set the number of times to perform pulse average in the range of 1 to 4096.

### Setting Deceleration Prediction and Stop Prediction

11. To enable deceleration prediction, use the **jog shuttle** and **SELECT** to turn Deceleration Prediction ON.
12. To enable stop prediction, use the **jog shuttle** and **SELECT** to set Stop Prediction in the range of 1.5 to 10 pulses.

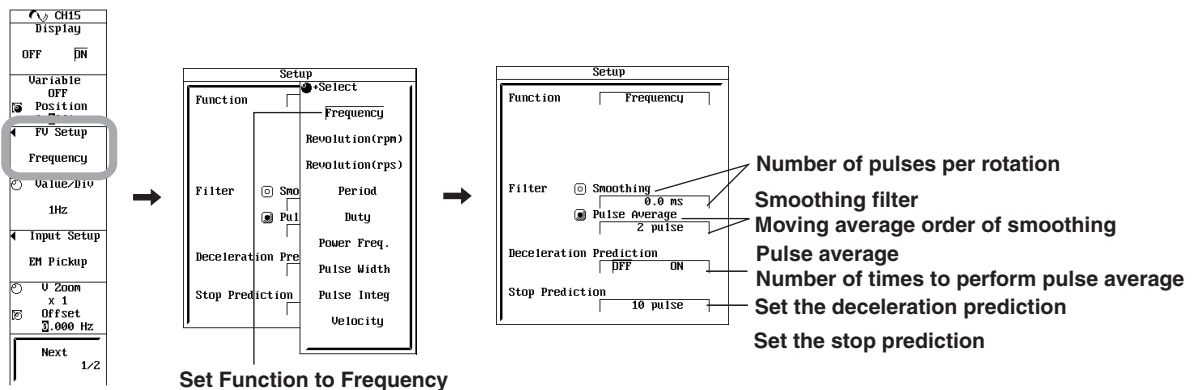

## When Measuring RPMs or RPSs

### Setting the Measurement Item

4. Press the **FV Setup** soft key. A setup dialog box opens.
5. Use the **jog shuttle** and **SELECT** to set Function to Revolution (rpm) or Revolution (rps).

### Setting the Number of Pulses per Rotation

6. Use the **jog shuttle** and **SELECT** to set Pulse/Rotate in the range of 1 to 99999 pulses.

### Setting Value/Div

7. Turn the V/DIV knob to set the Value/Div value. You can also set Value/Div by pressing the **Value/Div** soft key and turning the **jog shuttle**.

### Note

The unit for Value/Div and offset are synchronized to the unit of the measurement mode selected in steps 4 and 5. For the procedure of setting the offset value, see section 5.10.

Carry out steps 8 to 13 below as necessary.

### Setting the Smoothing Filter

8. To enable the smoothing filter, use the **jog shuttle** and **SELECT** to set Filter to Smoothing.
9. Use the **jog shuttle** and **SELECT** to set the moving average order of smoothing in the range of 0.0 to 1000.0 ms.

### Setting the Pulse Average

10. To enable the pulse average, use the **jog shuttle** and **SELECT** to select Pulse Average.
11. Use the **jog shuttle** and **SELECT** to set the number of times to perform pulse average in the range of 1 to 4096.

### Setting Deceleration Prediction and Stop Prediction

12. To enable deceleration prediction, use the **jog shuttle** and **SELECT** to turn Deceleration Prediction ON.
13. To enable stop prediction, use the **jog shuttle** and **SELECT** to set Stop Prediction in the range of 1.5 to 10 pulses.

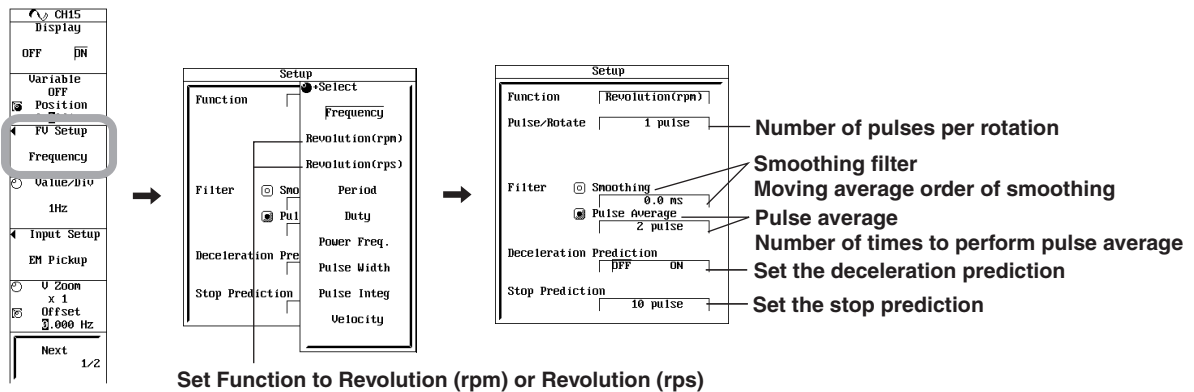

## 5.19 Setting the Frequency (Number of Rotations, Period, Duty Cycle, Power Supply Frequency, Pulse Width, Pulse Integration, and Velocity) Measurement

### When Measuring the Period

#### Setting the Measurement Item

4. Press the **FV Setup** soft key. A setup dialog box opens.
5. Use the **jog shuttle** and **SELECT** to set Function to Period.

#### Setting Value/Div

6. Turn the V/DIV knob to set the Value/Div value. You can also set Value/Div by pressing the **Value/Div** soft key and turning the **jog shuttle**.

#### Note

The unit for Value/Div and offset are synchronized to the unit of the measurement mode selected in steps 4 and 5. For the procedure of setting the offset value, see section 5.10.

Carry out steps 7 to 12 below as necessary.

#### Setting the Smoothing Filter

7. To enable the smoothing filter, use the **jog shuttle** and **SELECT** to set Filter to Smoothing.
8. Use the **jog shuttle** and **SELECT** to set the moving average order of smoothing in the range of 0.0 to 1000.0 ms.

#### Setting the Pulse Average

9. To enable the pulse average, use the **jog shuttle** and **SELECT** to select Pulse Average.
10. Use the **jog shuttle** and **SELECT** to set the number of times to perform pulse average in the range of 1 to 4096.

#### Setting Deceleration Prediction and Stop Prediction

11. To enable deceleration prediction, use the **jog shuttle** and **SELECT** to turn Deceleration Prediction ON.
12. To enable stop prediction, use the **jog shuttle** and **SELECT** to set Stop Prediction in the range of 1.5 to 10 pulses.

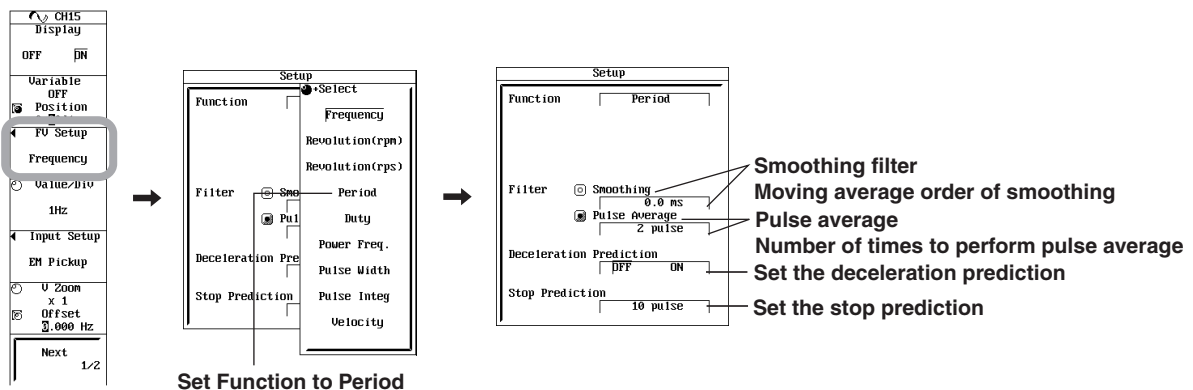

## When Measuring the Duty Cycle

### Setting the Measurement Item

4. Press the **FV Setup** soft key. A setup dialog box opens.
5. Use the **jog shuttle** and **SELECT** to set Function to Duty.

### Setting the Measurement Pulse

6. Use the **jog shuttle** and **SELECT** to set Measure Pulse to Positive or Negative.

### Setting Value/Div

7. Turn the V/DIV knob to set the Value/Div value. You can also set Value/Div by pressing the **Value/Div** soft key and turning the **jog shuttle**.

### Note

The unit for Value/Div and offset are synchronized to the unit of the measurement mode selected in steps 4 and 5. For the procedure of setting the offset value, see section 5.10.

Carry out steps 8 and 9 below as necessary.

### Setting the Smoothing Filter

8. To enable the smoothing filter, use the **jog shuttle** and **SELECT** to set Filter to Smoothing.
9. Use the **jog shuttle** and **SELECT** to set the moving average order of smoothing in the range of 0.0 to 1000.0 ms.

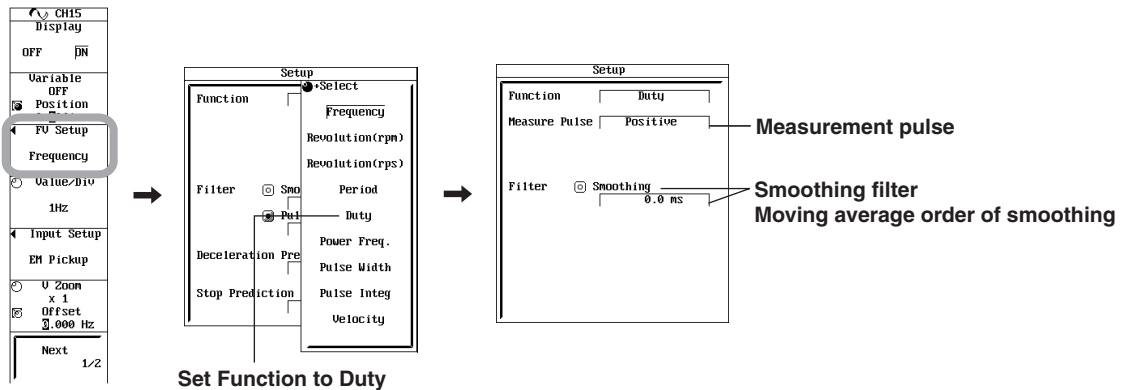

## 5.19 Setting the Frequency (Number of Rotations, Period, Duty Cycle, Power Supply Frequency, Pulse Width, Pulse Integration, and Velocity) Measurement

### When Measuring the Power Supply Frequency

#### Setting the Measurement Item

4. Press the **FV Setup** soft key. A setup dialog box opens.
5. Use the **jog shuttle** and **SELECT** to set Function to Power Freq.

#### Setting the Center Frequency

6. Use the **jog shuttle** and **SELECT** to set Center Frequency to 50 Hz, 60 Hz, or 400 Hz.

#### Setting Value/Div

7. Turn the V/DIV knob to set the Value/Div value. You can also set Value/Div by pressing the **Value/Div** soft key and turning the **jog shuttle**.

#### Note

The unit for Value/Div and offset are synchronized to the unit of the measurement mode selected in steps 4 and 5. For the procedure of setting the offset value, see section 5.10.

Carry out steps 8 to 11 below as necessary.

#### Setting the Smoothing Filter

8. To enable the smoothing filter, use the **jog shuttle** and **SELECT** to set Filter to Smoothing.
9. Use the **jog shuttle** and **SELECT** to set the moving average order of smoothing in the range of 0.0 to 1000.0 ms.

#### Setting the Pulse Average

10. To enable the pulse average, use the **jog shuttle** and **SELECT** to select Pulse Average.
11. Use the **jog shuttle** and **SELECT** to set the number of times to perform pulse average in the range of 1 to 4096.

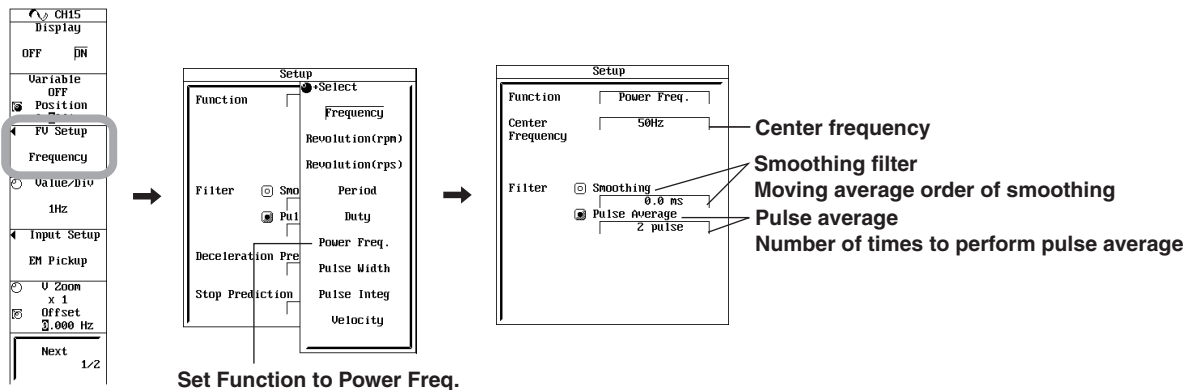

## When Measuring the Pulse Width

### Setting the Measurement Item

4. Press the **FV Setup** soft key. A setup dialog box opens.
5. Use the **jog shuttle** and **SELECT** to set Function to Pulse Width.

### Setting the Measurement Pulse

6. Use the **jog shuttle** and **SELECT** to set Measure Pulse to Positive or Negative.

### Setting Value/Div

7. Turn the V/DIV knob to set the Value/Div value. You can also set Value/Div by pressing the **Value/Div** soft key and turning the **jog shuttle**.

### Note

The unit for Value/Div and offset are synchronized to the unit of the measurement mode selected in steps 4 and 5. For the procedure of setting the offset value, see section 5.10.

Carry out steps 8 and 9 below as necessary.

### Setting the Smoothing Filter

8. To enable the smoothing filter, use the **jog shuttle** and **SELECT** to set Filter to Smoothing.
9. Use the **jog shuttle** and **SELECT** to set the moving average order of smoothing in the range of 0.0 to 1000.0 ms.

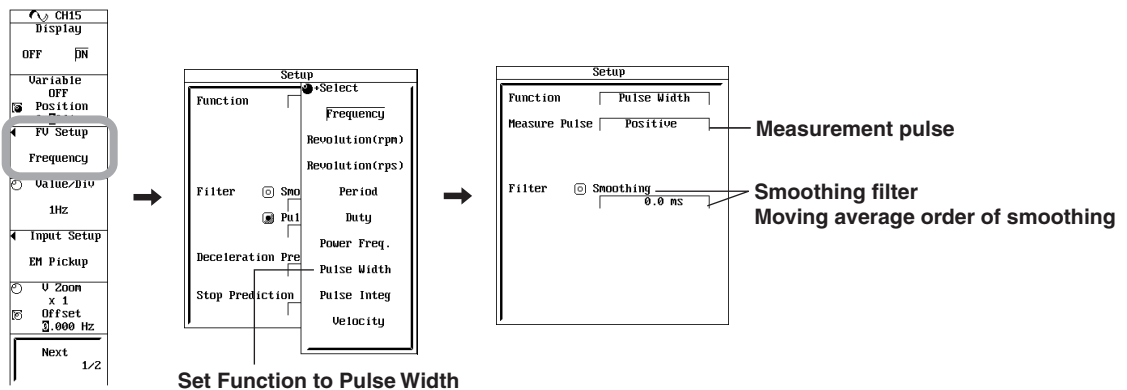

**5.19 Setting the Frequency (Number of Rotations, Period, Duty Cycle, Power Supply Frequency, Pulse Width, Pulse Integration, and Velocity) Measurement**

**When Measuring the Pulse Integration**

**Setting the Measurement Item**

4. Press the **FV Setup** soft key. A setup dialog box opens.
5. Use the **jog shuttle** and **SELECT** to set Function to Pulse Integ.

**Setting the Unit/Pulse and Unit**

6. Use the **jog shuttle** and **SELECT** to set Unit/Pulse in the range of  $-9.9999E-30$  to  $9.9999E+30$ .
7. As necessary, use the **jog shuttle** and **SELECT** to select Unit and enter the unit according to the procedure given in section 4.2.

**Setting Value/Div**

8. Turn the V/DIV knob to set the Value/Div value. You can also set Value/Div by pressing the **Value/Div** soft key and turning the **jog shuttle**.

**Note**

The unit for Value/Div and offset are synchronized to the unit of the measurement mode selected in steps 4 and 5. For the procedure of setting the offset value, see section 5.10.

**Resetting the Pulse Count**

9. To manually reset the pulse count, use the **jog shuttle** and **SELECT** to select Exec to the right of Reset. The pulse count is reset.
10. To reset the pulse count automatically when the range is exceeded, use the **jog shuttle** and **SELECT** to set Over Limit Reset to ON.

Carry out steps 11 to 14 below as necessary.

**Setting the Smoothing Filter**

11. To enable the smoothing filter, use the **jog shuttle** and **SELECT** to set Filter to Smoothing.
12. Use the **jog shuttle** and **SELECT** to set the moving average order of smoothing in the range of 0.0 to 1000.0 ms.

**Setting the Pulse Average**

13. To enable the pulse average, use the **jog shuttle** and **SELECT** to select Pulse Average.
14. Use the **jog shuttle** and **SELECT** to set the number of times to perform pulse average in the range of 1 to 4096.

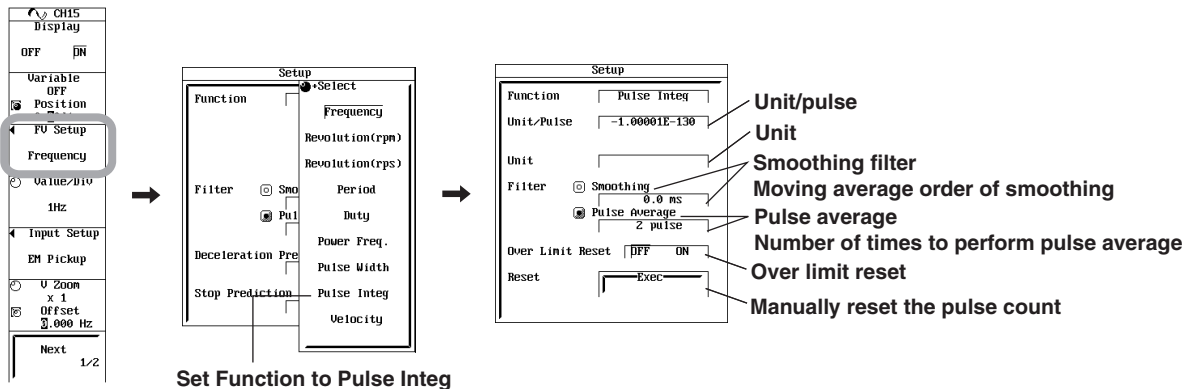



## When Measuring the Velocity

### Setting the Measurement Item

4. Press the **FV Setup** soft key. A setup dialog box opens.
5. Use the **jog shuttle** and **SELECT** to set Function to Velocity.

### Setting the Distance/Pulse

6. Use the **jog shuttle** and **SELECT** to set Distance/Pulse in the range of  $-9.9999\text{E}-30$  to  $9.9999\text{E}+30$ .

### Setting the Time Unit and Unit

7. Use the **jog shuttle** and **SELECT** to set **Time Unit** to hour, min, or sec.
8. Use the **jog shuttle** and **SELECT** to select **Unit** and enter the unit to be displayed on the screen according to the procedure given in section 4.2.

### Setting Value/Div

9. Turn the V/DIV knob to set the Value/Div value. You can also set Value/Div by pressing the **Value/Div** soft key and turning the **jog shuttle**.

### Note

The unit for Value/Div and offset are synchronized to the unit of the measurement mode selected in steps 4 and 5. For the procedure of setting the offset value, see section 5.10.

Carry out steps 10 to 15 below as necessary.

### Setting the Smoothing Filter

10. To enable the smoothing filter, use the **jog shuttle** and **SELECT** to set Filter to Smoothing.
11. Use the **jog shuttle** and **SELECT** to set the moving average order of smoothing in the range of 0.0 to 1000.0 ms.

### Setting the Pulse Average

12. To enable the pulse average, use the **jog shuttle** and **SELECT** to select Pulse Average.
13. Use the **jog shuttle** and **SELECT** to set the number of times to perform pulse average in the range of 1 to 4096.

### Setting Deceleration Prediction and Stop Prediction

14. To enable deceleration prediction, use the **jog shuttle** and **SELECT** to turn Deceleration Prediction ON.
15. To enable stop prediction, use the **jog shuttle** and **SELECT** to set Stop Prediction in the range of 1.5 to 10 pulses.

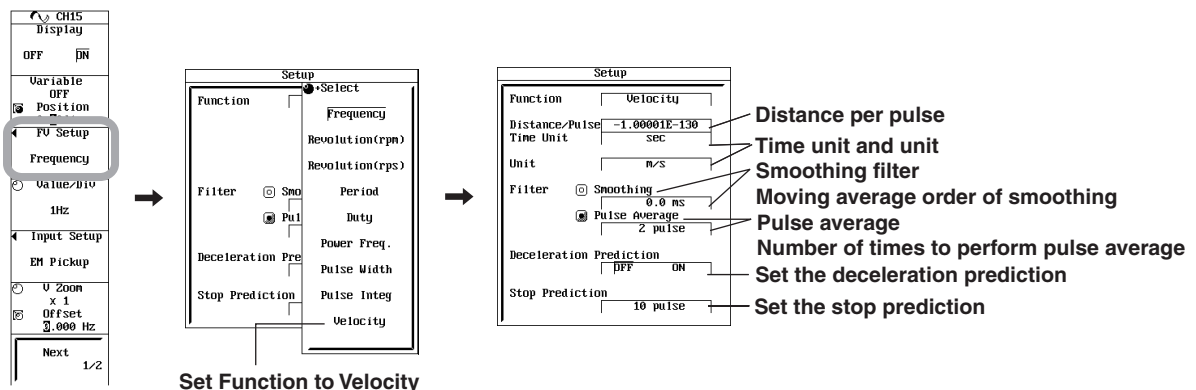

## Explanation

### Setting the Input: Input Setup

#### Preset

Select a preset to automatically enter settings appropriate for the signal (Some items need to be manually entered). If you select User (user-defined), all the setup items can be set arbitrarily. The following 10 presets are available. For details on the settings of each preset, see appendix 13.

- **Logic 5V, Logic 3V, Logic 12V, and Logic 24V**  
Use this preset when the output from the sensor or other equivalent item changes in the range of 0 V to 5 V (or 3 V, 12 V, or 24 V: supply voltage applied to the sensor). The voltage range is automatically set to the optimum voltage range, and the threshold level is automatically set to one-half the voltage.
- **Pull-up 5V**  
Use this preset when the sensor output is open collector or contact output. The pull-up function is enabled only when this preset is selected. The pull-up voltage is approximately 5 V, and the pull-up resistor is 4.7 k $\Omega$ . If you turn pull-up ON, set the input voltage in the range of 0 V to 5 V. If the input voltage exceeds this range, the protection circuit is tripped and the pull-up resistor is automatically cut off.
- **ZeroCross**  
Use this preset when the input voltage changes around 0 V. The input coupling is automatically set to AC, and the threshold level is automatically set to 0 V. When setting the voltage range, be sure that the maximum amplitude does not exceed the voltage range.
- **AC100V or AC200V**  
Use this preset when measuring the supply voltage of 100-V or 200-V power supply systems. The probe type is automatically set to 10:1; the voltage range is automatically set to a value suitable for the input voltage and probe factor; and the coupling is automatically set to AC. Be sure to use the isolated probe (700929) when measuring the power supply voltage.
- **EM Pickup: Electromagnetic Pickup**  
Use this preset when connecting the electromagnetic pickup directly. The voltage range is automatically set to  $\pm 1$  V, and the threshold level is automatically set to 0 V.
- **User: User-defined**  
Use this preset when entering the input conditions arbitrarily. Pull-up cannot be specified.

#### Note

- When measuring high voltage exceeding 42 V (AC+DCpeak) on the 701280 (FREQ), be sure to use the isolated probe (700929).
  - Use EM Pickup only when connecting the electromagnetic pickup.
  - When set to EM Pickup, the LEDs of the frequency module do not illuminate in red even when the range is exceeded.
  - The DL750/DL750P does not support electromagnetic pickups that require power supply or those that require terminators at the output. For these types of electromagnetic pickup, furnish appropriate measures on the sensor end.
  - The output from the electromagnetic pickup must be within 42 V<sub>P-P</sub>. The minimum sensitivity is 0.2 V<sub>P-P</sub>. If the output is less than the minimum sensitivity, the measured values may be unstable.
  - When using the pull-up function, do not let the voltage exceed the 0 to 5 V range. If the voltage exceeds the range, the protection circuit will be tripped, and the pull-up circuit will be cut off.
-

The following 10 input setup items are available.

• **Voltage Range: V Range**

Select the input voltage range ( $\pm$ FS) from the following:

- **When the probe attenuation is set to 1:1**  
 $\pm 1$  V,  $\pm 2$  V,  $\pm 5$  V,  $\pm 10$  V,  $\pm 20$  V, or  $\pm 50$  V ( $\pm$ FS)
- **When the probe attenuation is set to 10:1**  
 $\pm 10$  V,  $\pm 20$  V,  $\pm 50$  V,  $\pm 100$  V,  $\pm 200$  V, or  $\pm 500$  V ( $\pm$ FS)

• **Coupling**

Set the input coupling to DC or AC.

The description is the same as with the input coupling of other modules. See the functional explanation given in “Input Coupling” on page 2-8 and the explanation given in section 5.5.

• **Probe Type**

Select 1:1 or 10:1.

The description is the same as with the probe type of other modules. See the functional explanation given in “Probe Type” on page 2-9 and the explanation given in section 5.6.

• **Bandwidth Limit**

Set the bandwidth limit to 100 Hz, 1 kHz, 10 kHz, 100 kHz, or Full. You cannot select Full when the preset is set to AC100V or AC200V.

• **Threshold Level**

Set the level within FS of the input voltage range. The resolution is a value corresponding to 1% of FS.

• **Hys (Hysteresis)**

Set the hysteresis to  $\pm 1\%$ ,  $\pm 2.5\%$ , or  $\pm 5\%$  of the FS of the input voltage range.

• **Slope**

Select  $\nearrow$  (rising) or  $\searrow$  (falling).

• **Chatter Elimination**

Eliminates the chatter that occurs such when the contact input is turned ON/OFF.

The changes in the signal over the specified time can be discarded. Set the interval in the range of 0 to 1000 ms (1-ms resolution). When 0 ms is selected, the chatter elimination function is turned OFF.

Chattering elimination is effective against both the rising and falling edges.

• **Pull Up**

You can turn ON/OFF pull-up only when the preset is set to Pull-up 5V. Pull-up is not possible in other presets.

When using pull-up, set the input voltage in the range of 0 V to 5 V. If a voltage exceeding this range is applied, the internal protection circuit will cut off the pull-up circuit.

**Internal equivalent circuit when using pull-up**

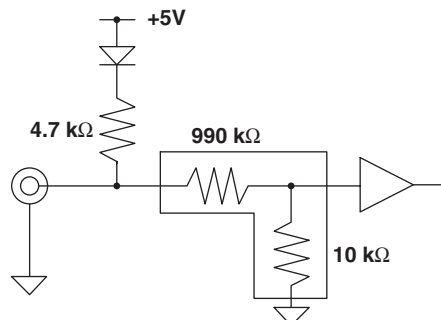

**5.19 Setting the Frequency (Number of Rotations, Period, Duty Cycle, Power Supply Frequency, Pulse Width, Pulse Integration, and Velocity) Measurement**

**Setting the Measurement Item: Function**

The following nine items are available.

• **Frequency**

Frequency (Hz) =  $1/T_w$  (s)  
 Measurable range: 0.01 Hz to 200 kHz

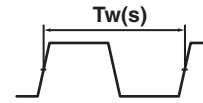

• **Period**

Period (s) =  $T_w$  (s)  
 Measurable range: 5 μs to 50 s

• **RPMs/RPSs**

RPMs = Frequency (Hz)/the number of pulses per rotation (Nr) × 60  
 Measurable range: 0.01 rpm to 100000 rpm  
 RPSs = Frequency (Hz)/the number of pulses per rotation (Nr)  
 Measurable range: 0.001 rps to 2000 rps

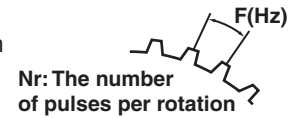

• **Duty Cycle**

Duty cycle (%) =  $T_{high} / T_w$  (s)  
 Or, duty cycle (%) =  $T_{low} / T_w$  (s)  
 Measurable range: 0% to 100%

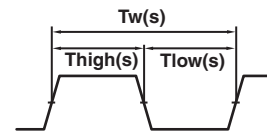

• **Pulse Width**

Pulse width (s) =  $T_{high}$  (s)  
 or pulse width (s) =  $T_{low}$  (s)  
 Measurable range: 2 μs to 50 s

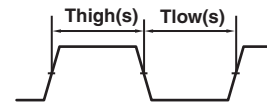

• **Power Supply Frequency**

Power supply frequency (Hz) =  $1/T_w$  (s)  
 Resolution: 0.01 Hz  
 Measurable range: (50 Hz, 60 Hz, or 400 Hz) ± 20 Hz

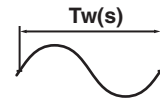

• **P& se Integration (Distance/Flow Rate)**

Pulse integrated value = N (count) × physical amount per pulse (l)  
 Set the physical amount per pulse (l) to distance or flow rate.  
 A suitable user-defined unit can be assigned to the specified physical amount.  
 Measurable range: Up to  $2 \times 10^9$  counts

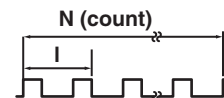

• **Velocity**

Velocity (km/h) = Distance per pulse l (km)/ $T_w$  (s) × 3600  
 Velocity (m/s) = Distance per pulse l (m)/ $T_w$  (s)  
 The distance and unit can be user defined (angular velocity, etc.).  
 Measurable range:  $F (=1/T_w) = 0.01$  Hz to 200 kHz

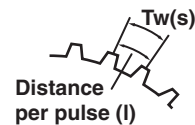

**Setup Items for Each Measurement Item**

**When the Measuring Rotation**

- **Pulse/Rotate**  
Set the number of pulses per rotation in the range of 1 to 99999 pulses.

**When Measuring the Duty Cycle or Pulse Width**

- **Measure Pulse**  
Set the measurement pulse to Positive or Negative.
  - **When Measuring the Duty Cycle**  
Positive: Measures the ratio of the positive pulses.  
Negative: Measures the ratio of the negative pulses.
  - **When Measuring the Pulse Width**  
Positive: Measures the width of the positive pulse.  
Negative: Measures the width of the negative pulse.

• **When Positive is selected**

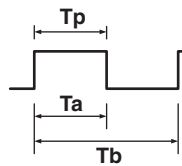

**Pulse width:**  
Measures the width of Tp  
**Duty:**  
Measures Ta/Tb

• **When Negative is selected**

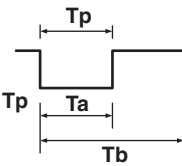

**Pulse width:**  
Measures the width of Tp  
**Duty:**  
Measures Ta/Tb

**Precautions to Be Taken When Measuring the Duty Cycle**

The output is set to 0% or 100% when either of the conditions below is met when measuring the duty cycle.

- When there is no pulse input after a time equal to 4 times the period of the pulse that was input immediately before.
- When there is no pulse input for 20 s.

When the measurement pulse is set to Positive, the output is set to 0% when the pulse input is low when the condition is met and 100% when the pulse input is high. When the measurement pulse is set to Negative, the output is set to 0% when the pulse input is high when the condition is met and 100% when the pulse input is low.

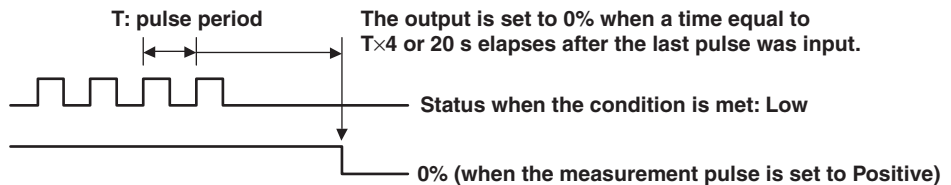

**When Measuring the Power Supply Frequency**

- **Center Frequency**  
Set the center frequency to 50 Hz, 60 Hz, or 400 Hz.

**When Measuring the Pulse Integration**

- **Unit/Pulse**  
Set the physical amount per pulse in the range of  $-9.9999E+30$  to  $9.9999E+30$ .
- **Unit**  
As necessary, enter the unit of pulse integration to be displayed on the screen using up to 4 characters.
- **Over Limit Reset**  
Select ON to reset the pulse count automatically when the range is exceeded. Select OFF to not reset the pulse count. The default setting is OFF.
- **Reset**  
To reset the pulse count manually, select Exec.

**When Measuring the Velocity**

- **Distance/Pulse**

Set the distance per pulse in the range of  $-9.9999E+30$  to  $9.9999E+30$ .

- **Time Unit**

Set the time unit to hour, min, or sec.

The output is automatically converted to a velocity with respect to the specified time.

- **Unit**

Set the unit of the velocity to be displayed on the screen using up to 4 characters.

The default setting is m/s.

**Filter**

Computation such as smoothing filter and pulse average can be performed depending on the selected measurement mode.

- Smoothing

Set the moving average order of smoothing in the range of 0.0 to 1000.0 ms.

- Pulse Average

Set the number of times to perform pulse average in the range of 1 to 4096.

**Deceleration Prediction**

Select ON to automatically compute and predict the deceleration curve from the elapsed time after the pulse stops. Select OFF to not perform deceleration prediction.

**Stop Prediction**

Set the time from the point when the pulse input stops to the point when the function determines that the object has stopped. The time can be set to  $\times 1.5$ ,  $\times 2$ ,  $\times 3$ , ... ,  $\times 9$ , and  $\times 10$  (10 settings) of the pulse period (T) of the pulse one period before the pulse input stopped. Select OFF to not perform stop prediction.

# 5.20 Setting Logic Waveforms

<For a description of this function, refer to page 2-19.>

## Procedure

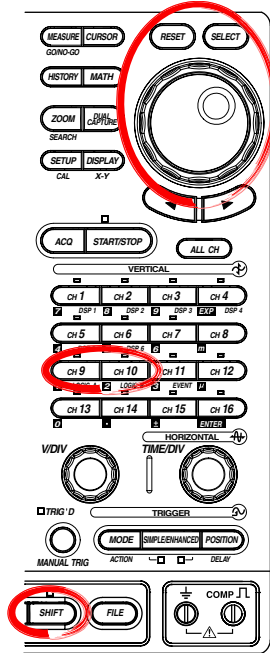

1. Press **SHIFT+CH9(LOGIC A)** or **SHIFT+CH10(LOGIC B)**.

### Note

For a description of setting the vertical position, see section 5.4. For a description of zooming vertically by setting the zoom rate, see section 5.8. For a description of setting waveform labels, see section 8.10.

### Turning ON/OFF Logic Waveforms

2. Press the **Display** soft key to select ON or OFF.

### Turning ON/OFF the Bit Display

3. Press the **Display Bits** soft key to display the display ON/OFF setup screen.
4. Turn the **jog shuttle** to move the cursor to the bit you wish to turn ON.
5. Press **SELECT** to turn it ON.  
You can turn ON all items at once by selecting All ON.  
You can turn OFF all items at once by selecting All OFF.
6. As necessary, repeat steps 4 and 5.

### Selecting the Bit Display Position

7. Press the **Bit Mapping** soft key to select Fixed or Auto.

### Setting Labels for Each Bit

8. Press the **Bit Label** soft key. A setup dialog box opens.
9. Turn the **jog shuttle** to move the cursor to the bit on which to set the label and enter the label according to the procedures given in section 4.2.

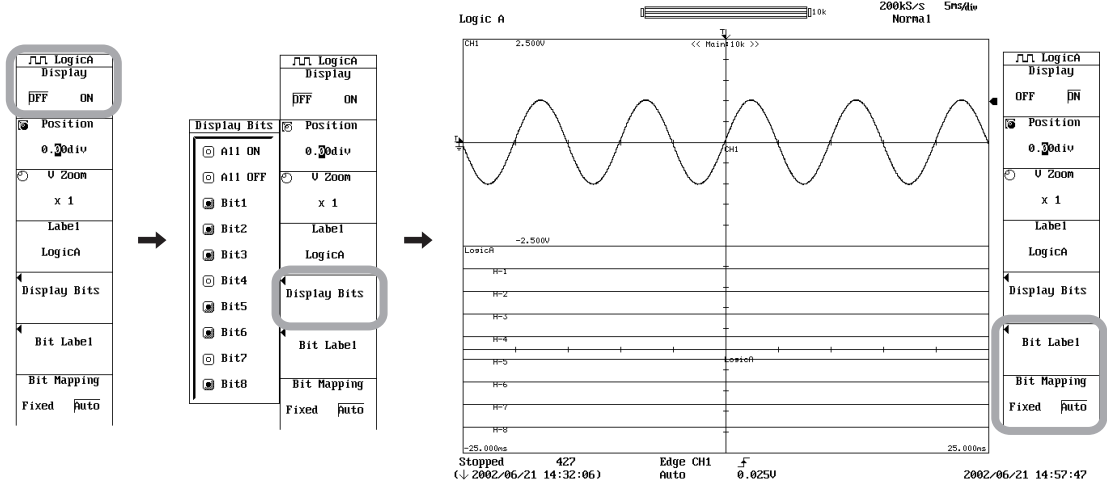

**Explanation**

**Turning ON/OFF the Bit Display**

You can specify whether to display the waveform for each bit.

**Bit Display Position: Bit Mapping**

- Fixed: A space is allocated for bits that are turned OFF.
- Auto: A space is not allocated for bits that are turned OFF.  
Only the bits that are turned ON are displayed in order from the top.

**Fixed (when bit 7 of LOGIC A is OFF)**

A1
A2
A3
A4
A5
A6
A8

**Auto (when bit 7 of LOGIC A is OFF)**

A1
A2
A3
A4
A5
A6
A8

**Setting Labels for Each Bit**

Alphanumeric characters that can be entered: Up to 8 characters



## 5.21 Setting Event Waveforms

<For a description of this function, refer to page 2-19.>

### Procedure

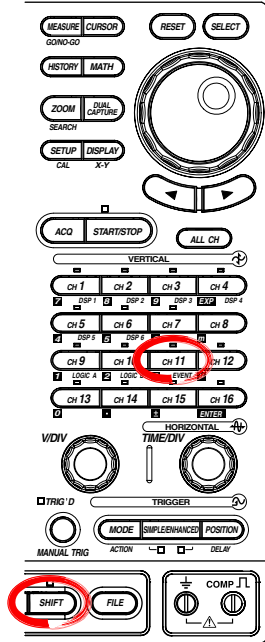

1. Press **SHIFT+CH11(EVENT)**.

### Note

For a description of turning ON/OFF the event waveform, see section 5.1. For a description of setting the vertical position, see section 5.4. For a description of zooming vertically by setting the zoom rate, see section 5.8. For a description of setting waveform labels, see section 8.10.

### Selecting the Event Waveform to Be Displayed

2. Press the **Display Bits** soft key.
3. Press the **Dual Capture** or **Voice** soft key to select ON or OFF.

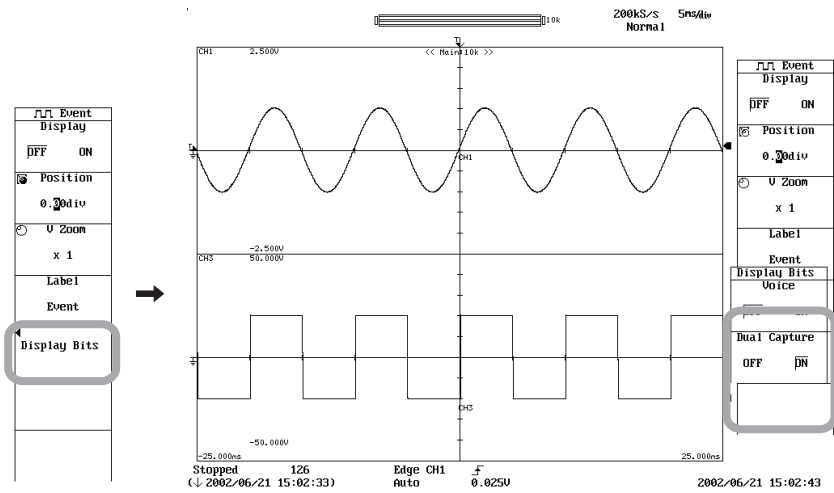

**Explanation**

**Selecting the Event Waveform to Be Displayed: Display Bits**

You can select the event waveform you wish to display and turn it ON/OFF.

Dual Capture: Displays the times when triggers are activated when using the dual capture function (see section 7.6) as event waveforms.

Voice: Indicates the interval of the voice memo that has been recorded using the voice memo function (see section 7.9). The interval during which a voice memo is recorded is from the rising edge to the falling edge of the event waveform.

**Notes Regarding the Event Waveform (Voice Memo Function)**

- If the record length setting is set long in the ACQ menu causing the number of channels that can be used to 3 channels or less, event waveforms are not displayed. In this case, the voice memo function cannot be used.
  - If the voice memo function is OFF (Voice Memo menu > Mode: OFF) even when the event waveform display is ON (Display Bits > Voice: ON), event waveforms are not saved when waveform data is saved. In addition, even if a voice memo is recorded during waveform acquisition, if the voice memo function is turned OFF at the time waveform data is saved, event waveform data/voice data will not be saved.
  - In realtime recording, if the valid number of channels<sup>1</sup> is 3 channels or less, event waveforms cannot be used. In this case, the voice memo function cannot be used.
1. Valid number of channels signify the number of channels that are turned ON excluding MATH1 to MATH8 channels. However, for LOGIC A and LOGIC B, the number of channels is counted as 1 regardless of whether one of the channels is ON or both channels are ON.

**Format of Event Waveform**

For event waveforms, the following format is used.

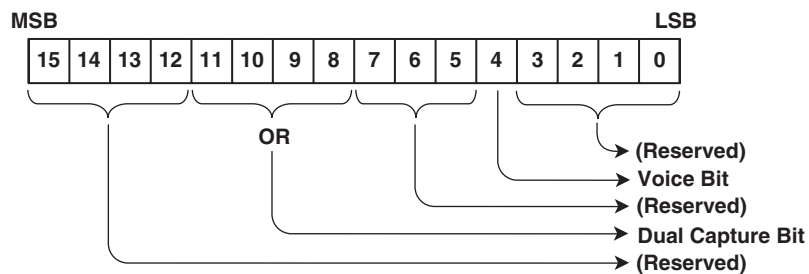

# 6.1 Setting the Trigger Mode

<For a description of this function, refer to page 2-27.>

## Procedure

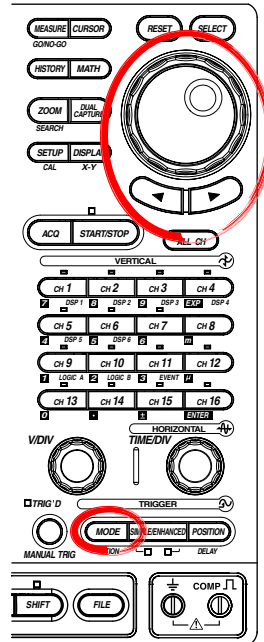

1. Press **MODE**.
2. Press the soft key corresponding to the desired mode to set the trigger mode.
3. If you select Single(N), turn the **jog shuttle** to set Single(N) Count (the number of times to acquire the waveform).

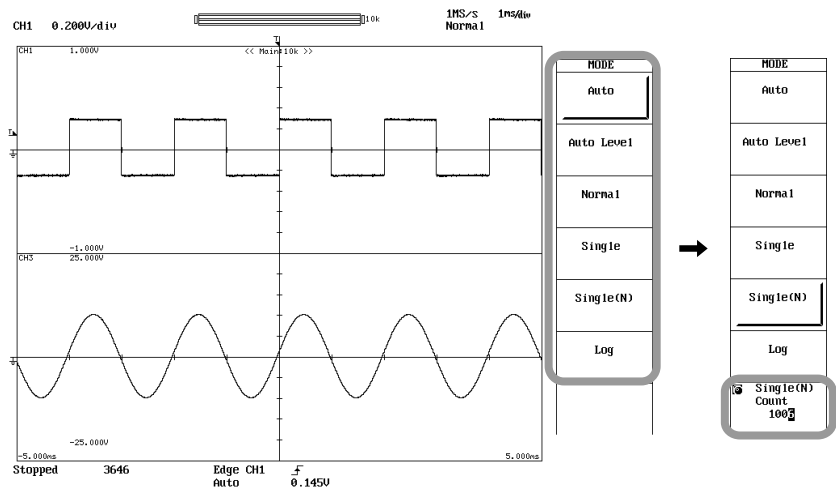

## Explanation

### Auto Mode

If the trigger condition is met within the 50-ms timeout period, the waveform is updated on each trigger occurrence. If the trigger condition is not met after the timeout period elapses, the waveform is automatically updated. If the time axis setting is in the range in which the display mode is set to roll mode, the display is set to roll mode. However, triggering operates in normal mode when using simple trigger with the trigger source set to Time, even if auto mode is specified.

### Auto Level Mode

Within the timeout period (approximately 1 s), the waveforms are displayed in the same fashion as in the auto mode. If a trigger does not occur within the timeout period (approximately 1 s), the center value of the amplitude of the trigger source is detected, the trigger level is automatically changed to the center value, and the trigger is generated to update the displayed waveform. The auto-level mode is valid only if the trigger is a simple trigger and the trigger source is between CH1 and CH16. For all other cases, the operation is the same as the auto mode. If the time axis setting is in the range in which the display mode is set to roll mode, the display is set to roll mode.

## 6.1 Setting the Trigger Mode

---

### **Normal Mode**

The display is updated only when the trigger conditions are met. The display is not updated if the trigger does not occur. Therefore, to check the waveform or ground level when no trigger is detected, use auto mode.

### **Single Mode**

The display is updated once when the trigger conditions are met and the waveform acquisition stops. In the time axis setting range in which the display mode is set to roll mode, the display is set to roll mode. When a trigger occurs, the specified record length of data is acquired and the displayed waveform stops.

### **Single (N) Mode**

When the trigger condition is met, the waveform is acquired the specified number of times and stops. This mode is used when acquiring a waveform using the sequential store function.

### **Log Mode**

In this mode, the trigger settings are disabled. The specified record length of data is acquired once when acquisition is started, and the displayed waveforms are updated. If the time axis setting is in the range in which the display mode is set to roll mode, the display is set to roll mode.

### **Note**

- 
- The trigger mode setting applies to both simple and enhanced triggers.
  - In the recorder mode of the DL750P (see chapter 9), select the trigger mode from Auto, Repeat, Single, and Log. For details on the Repeat mode, see section 9.3.
-

## 6.2 Setting the Trigger Position

<For a description of this function, refer to page 2-28.>

### Procedure

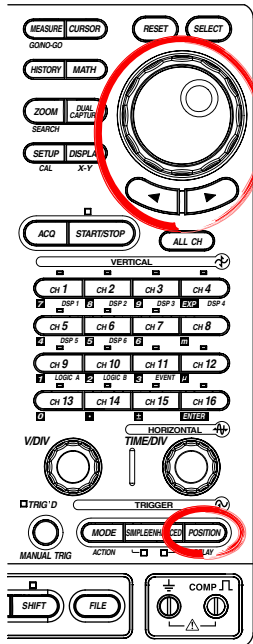

1. Press **POSITION**.
2. Turn the **jog shuttle** to set the **trigger position**.  
If you wish to select 10%, 50%, or 90%, you can press the corresponding soft key.  
Pressing **RESET** resets the position to 50%.

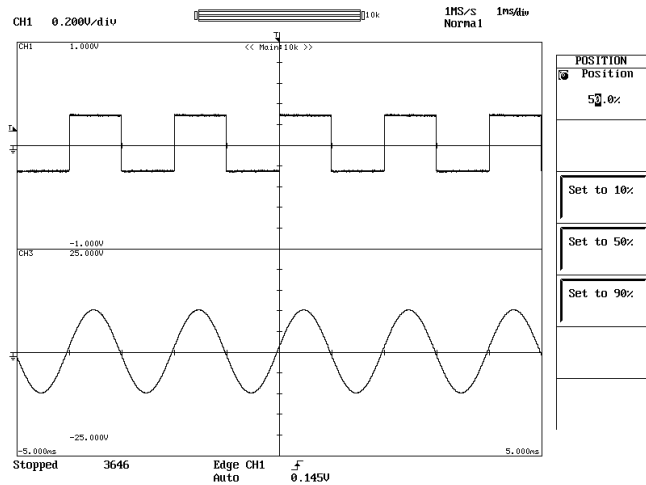

### Explanation

#### Trigger Position

Trigger position = Trigger point + trigger delay

You can select the location of the trigger position on the screen.

If the trigger delay is 0 s, the trigger position and the trigger point match.

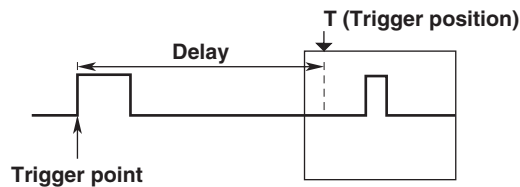

#### Selectable Range of Trigger Position

With the display record length taken to be 100%, set in the range of 0 to 100% (in 0.1% steps).

#### Trigger Position Marker

A position marker (T) appears at the top of the screen. The marker indicates the trigger position with respect to the display record length.

## 6.2 Setting the Trigger Position

### Time Reference Mark

A ↓ mark is displayed at the time reference position of the acquisition data separately from the trigger position.

- **When Set to a Mode Other Than Roll Mode**

Normally, the time reference point and the trigger position are displayed at the same position, because they match.

If the waveform acquisition is stopped in the middle of the operation, the preset trigger position and the actual trigger position (trigger point) are offset, because not all the data of the pre-trigger section and post-trigger section have not been acquired. In this case, the time reference mark is offset from the trigger position mark, because it indicates the actual trigger point.

**When the time reference mark is displayed overlapped with the trigger position mark**  
(↓)

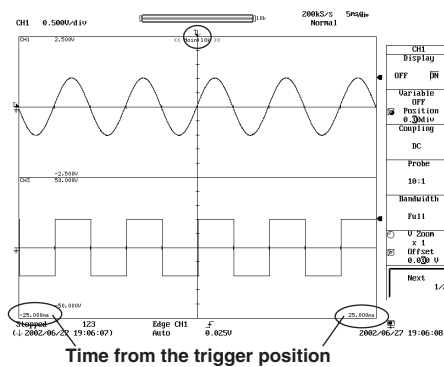

**When the time reference mark is displayed offset from the trigger position mark**

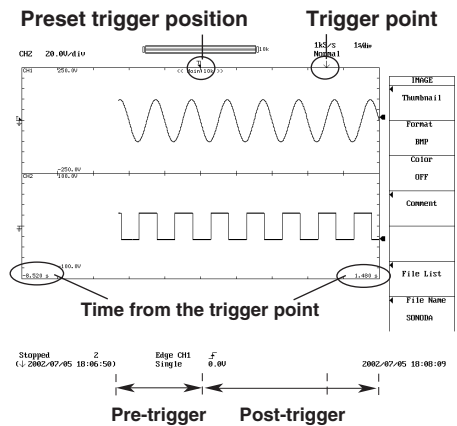

- **For Roll Mode Display**

When the trigger mode is set to Auto or Auto Level, the reference point is the point when the waveform acquisition was stopped.

When the trigger mode is set to Log, the reference point is the point when the waveform acquisition was started.

**When trigger mode is set to Auto/Auto Level**  
Time reference point

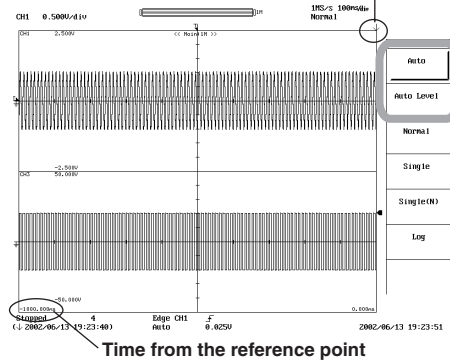

**When trigger mode is set to Log**  
Time reference point

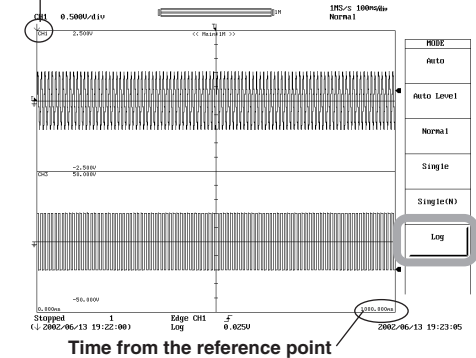

### Notes for Setting the Trigger Position

- If you change the trigger position while waveform acquisition is stopped, the new setting will not become effective until acquisition is started and the waveform is updated.
- Note that cursor time measurements are with respect to the trigger position. Changing the trigger position therefore changes the measurement values (except when in roll mode display).
- If you change the T/div setting, the time axis setting is rescaled with respect to the trigger position.

## 6.3 Setting the Trigger Delay

<For a description of this function, refer to page 2-28.>

### Procedure

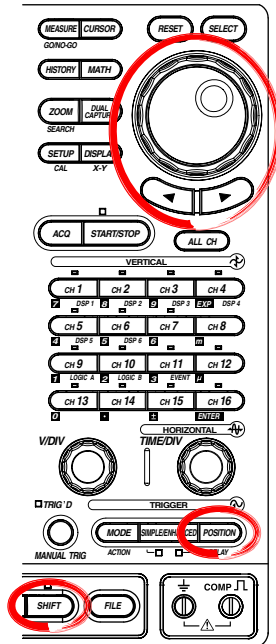

1. Press **SHIFT+POSITION**.
2. Turn the **jog shuttle** to set the trigger delay.  
Press **RESET** to reset the value corresponding to the selected unit to 0.0  $\mu$ s.

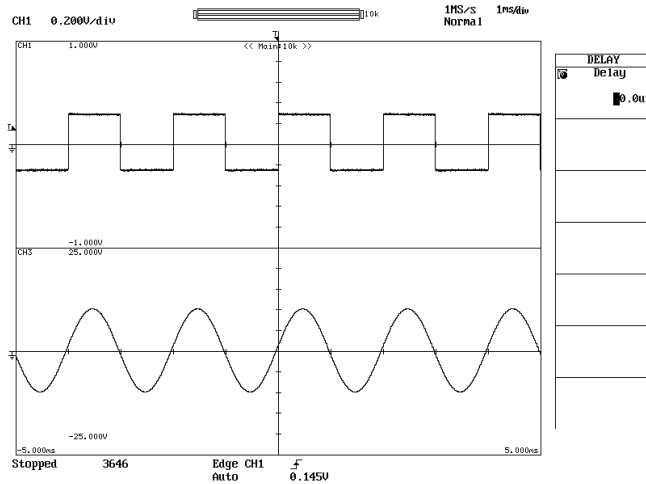

### Explanation

Although the display usually shows the waveform before and after the trigger point, it is possible to display the acquired waveform after a fixed time period elapses using the delay function.

#### Selectable Range of Trigger Delay

0 to 10 s  
(Minimum resolution is 100 ns.)

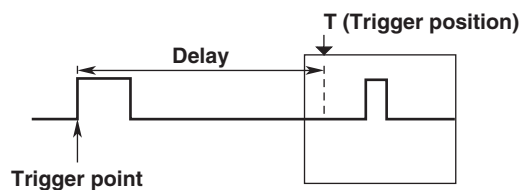

#### Notes for Setting the Trigger Delay

- When T/div is changed, the trigger delay remains unchanged.

## 6.4 Setting the Hold Off Time

<For a description of this function, refer to page 2-29.>

### Procedure

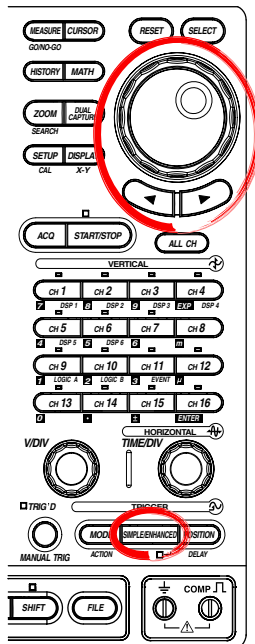

1. Press **SIMPLE/ENHANCED**.
2. Press the **Hold Off** soft key.
3. Turn the **jog shuttle** to set the hold off time.  
Pressing **RESET** resets the value to 0.0  $\mu$ s.

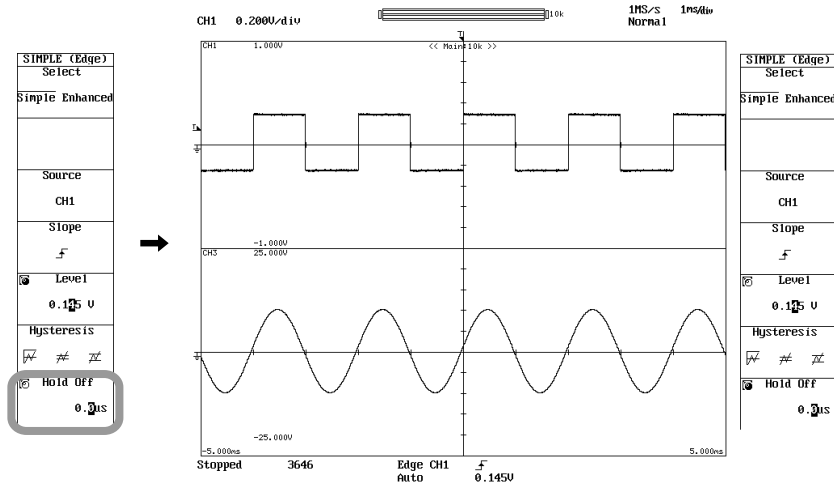

### Note

The hold off time setting applies to simple trigger and enhanced triggers.

### Explanation

This function prevents a trigger from being activated for a specified time, even if the trigger conditions are met during this time. This is useful when you wish to activate the trigger in sync with a periodic signal as shown in the figure below.

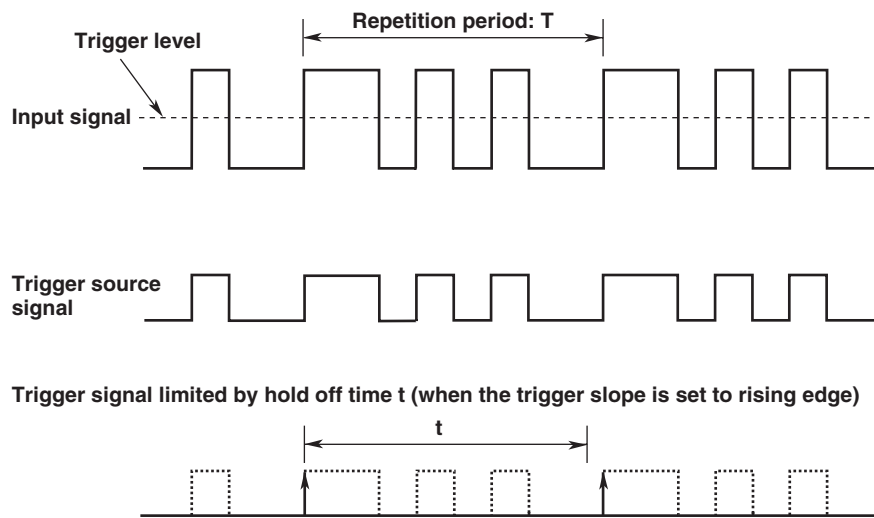



### Selectable Range of Hold Off Time

0 ns to 10 s (the initial value is 0 ns). The resolution is 100 ns.

### Notes for Setting the Hold Off Time

- If you are setting the hold off time to 50 ms or greater, set the trigger mode to normal.
- When used with A->B(N) or A Delay B trigger, the hold off time applies only to condition B.
- The hold off time is set to 0 ns for Period trigger, and this function is invalid.

## 6.5 Setting the Edge Trigger (SIMPLE)

<For a description of this function, refer to page 2-20.>

### Procedure

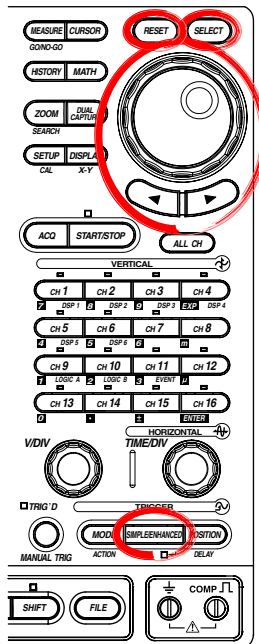

1. Press **SIMPLE/ENHANCED**.
2. Press the **Select** soft key to select Simple.

### Setting the Trigger Source

3. Press the **Source** soft key. The trigger source selection menu appears.
4. Use the **jog shuttle** and **SELECT** to select the trigger source from CH1 to CH16, DSP1 to DSP6 (optional).

### Note

The menu does not appear for channels without modules.

### Setting the Trigger Level

5. Press the **Level** soft key.
6. Turn the **jog shuttle** to set the trigger level. Press **RESET** to set the trigger level to 0.

### Note

The trigger level setting applies to both simple and enhanced triggers.

### Setting the Trigger Slope

7. Press the **Slope** soft key to select  $\uparrow$ ,  $\downarrow$ , or  $\uparrow\downarrow$ .

### Setting the Hysteresis

8. Press the **Hysteresis** soft key to select  $\overline{\uparrow\downarrow}$ ,  $\overline{\uparrow}$ , or  $\overline{\downarrow}$ .

### Setting the Hold Off

9. Set the hold off time according to the procedures given in section 6.4.

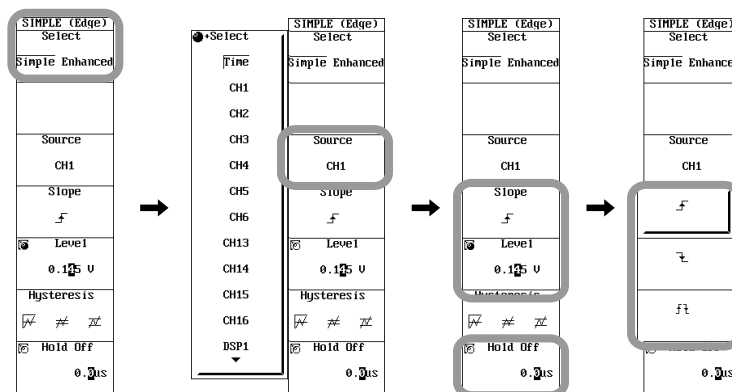

DSP1 to DSP6 are optional.

**Explanation**

An edge trigger is generated when the trigger source signal crosses a specified level.

**Setting the Trigger Source**

Select the trigger source from CH1 to CH16, DSP1 to DSP6 (optional).

**Note**

If you set the trigger source to a value other than CH1 to CH16, DSP1 to DSP6 (optional), see the sections below.

- Time: Section 6.8, "Setting the Timer Trigger (SIMPLE)"
- LogicA, Logic B: Section 6.9, "Setting the Logic Trigger (SIMPLE)"
- Ext (TRIG IN terminal of the side panel): Section 6.6, "Setting the External Trigger."
- Line (commercial power supply signal): Section 6.7, "Generating Triggers on the Power Signal (SIMPLE)"

**Setting the Trigger Level**

- **When Measuring Voltage**

Selectable range:  $\pm(V/\text{div}) \times 10$

Resolution: Varies depending on the input module.

- **When Measuring Temperature**

Selectable range: Measurement range of each thermocouple

Resolution: 0.1°C, 0.1 K, or 0.1°F (set within the measurement range (varies depending on the thermocouple type))

For a description of the measurement range of thermocouples, see section 5.16.

- **When observing strain**

Selectable range:  $\pm(\text{Measurement range})$

Resolution: 1  $\mu\text{STR}$  or 0.0005 mV/V

**Trigger Level and Resolution**

The resolution varies depending on the input module as follows:

**When Measuring Voltage (When the Probe Attenuation Is 1:1)**

V/div	Input Module				
	701250/701255/ 701261/701262	701251	701265	701260	701275
0.1 mV/div	-	-	0.001 mV	-	-
0.2 mV/div	-	-	0.002 mV	-	-
0.5 mV/div	-	-	0.005 mV	-	-
1 mV/div	-	0.01 mV	0.01 mV	-	-
2 mV/div	-	0.02 mV	0.02 mV	-	-
5 mV/div	0.05 mV	0.05 mV	0.05 mV	-	0.05 mV
10 mV/div	0.1 mV	0.1 mV	0.1 mV	-	0.1 mV
20 mV/div	0.2 mV	0.2 mV	0.2 mV	0.2 mV	0.2 mV
50 mV/div	0.5 mV	0.5 mV	0.5 mV	0.5 mV	0.5 mV
100 mV/div	0.001 V	0.001 V	0.001 V	0.001 V	0.001 V
200 mV/div	0.002 V	0.002 V	0.002 V	0.002 V	0.002 V
500 mV/div	0.005 V	0.005 V	0.005 V	0.005 V	0.005 V
1 V/div	0.01 V	0.01 V	0.01 V	0.01 V	0.01 V
2 V/div	0.02 V	0.02 V	0.02 V	0.02 V	0.02 V
5 V/div	0.05 V	0.05 V	0.05 V	0.05 V	0.05 V
10 V/div	0.1 V	0.1 V	0.1 V	0.1 V	0.1 V
20 V/div	0.2 V	0.2 V	-	0.2 V	-
50 V/div	-	-	-	0.5 V	-
100 V/div	-	-	-	0.001 kV	-
200 V/div	-	-	-	0.002 kV	-

The resolution is 0.01 div on all modules.

## 6.5 Setting the Edge Trigger (SIMPLE)

### When Measuring Temperature

Range	Resolution
K, E, J, T, L, U, N, R, S, B, W	0.1°C
Au7Fe	0.1 K

### Setting the Trigger Slope

Select how the trigger source is to cross the specified level for activating the trigger from the following three choices.

- ↗: Activated when the trigger source changes from below the trigger level to above the trigger level (rising).
- ↘: Activated when the trigger source changes from above the trigger level to below the trigger level (falling).
- ↕: Activated on either a rising edge or falling edge.

### Setting the Trigger Hysteresis

Sets a width to the trigger level so that triggers are not activated by small changes in the trigger signal. Select the trigger hysteresis from the following three types.

- **When Measuring Voltage**

- ↗: Approx.  $\pm 0.1$  division of hysteresis around the trigger level.
- ↘: Approx.  $\pm 0.5$  division of hysteresis around the trigger level.
- ↕: Approx.  $\pm 1$  division of hysteresis around the trigger level.

- **When Measuring Temperature**

- ↗: Approx.  $\pm 0.5^\circ\text{C}$  (K, °F)
- ↘: Approx.  $\pm 1^\circ\text{C}$  (K, °F)
- ↕: Approx.  $\pm 2^\circ\text{C}$  (K, °F)

- **When Measuring Strain**

- Hysteresis of approximately  $\pm 2.5\%$  of the range around the trigger level.
- Hysteresis of approximately  $\pm 12.5\%$  of the range around the trigger level.
- Hysteresis of approximately  $\pm 25\%$  of the range around the trigger level.

- **When Measuring Acceleration**

- ↗: Hysteresis of approximately  $\pm 0.1$  divisions of the range around the trigger level.
- ↘: Hysteresis of approximately  $\pm 0.5$  divisions of the range around the trigger level.
- ↕: Hysteresis of approximately  $\pm 1$  division of the range around the trigger level.

- **When Measuring Frequency and Other Parameters on the Frequency Module**

- ↗: Hysteresis of approximately  $\pm 0.01$  divisions of the range around the trigger level.
- ↘: Hysteresis of approximately  $\pm 0.5$  divisions of the range around the trigger level.
- ↕: Hysteresis of approximately  $\pm 1$  division of the range around the trigger level.

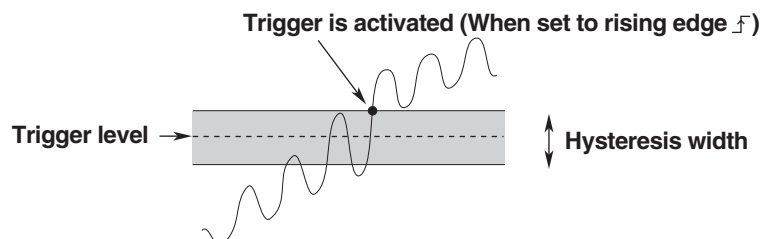

### Setting the Hold Off

For details, see section 6.4, “Setting the Hold Off Time.”

## 6.6 Setting the External Trigger (SIMPLE)

<For a description of this function, refer to page 2-20.>

### Procedure

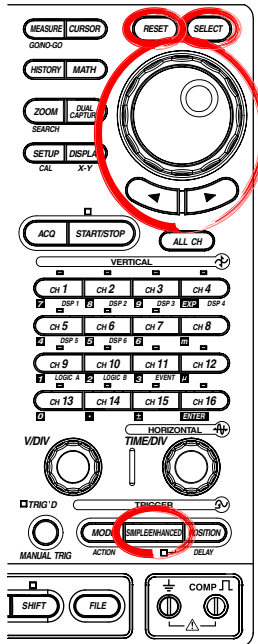

1. Press **SIMPLE/ENHANCED**.
2. Press the **Select** soft key to select Simple.

### Setting the Trigger Source

3. Press the **Source** soft key. The trigger source selection menu appears.
4. Use the **jog shuttle** and **SELECT** to select Ext.

### Setting the Trigger Slope

5. Press the **Slope** soft key to select  $\uparrow$  or  $\downarrow$ .

### Setting the Hold Off

6. Set the hold off time according to the procedures given in section 6.4.

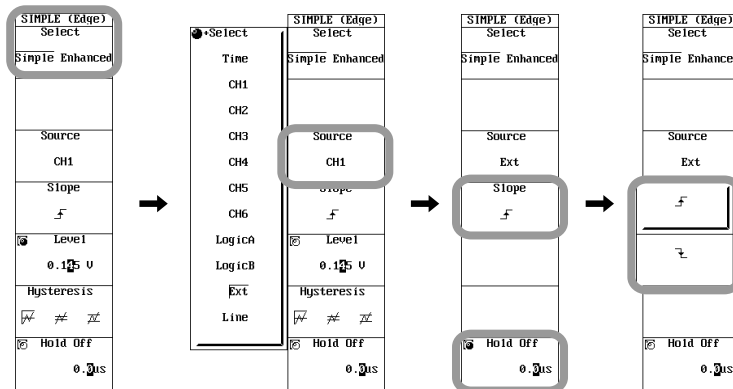

DSP1 to DSP6 are optional.

### Explanation

The external signal that is input through the TRIG IN terminal on the left side panel of the DL750/DL750P can be used to generate triggers.

### Note

For details on the TRIG IN terminal, see section 14.1.

### Setting the Trigger Source

Select Ext.

### Setting the Trigger Slope

Select how the trigger source is to cross the specified level for activating the trigger from the following two choices.

- $\uparrow$ : Activated when the trigger source changes from below the trigger level to above the trigger level (rising).
- $\downarrow$ : Activated when the trigger source changes from above the trigger level to below the trigger level (falling).

### Setting the Hold Off

For details, see section 6.4, "Setting the Hold Off Time."

## 6.7 Generating Triggers on the Power Signal (SIMPLE)

<For a description of this function, refer to page 2-20.>

### Procedure

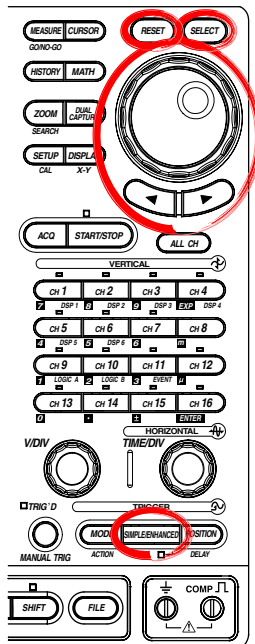

1. Press **SIMPLE/ENHANCED**.
2. Press the **Select** soft key to select Simple.

### Setting the Trigger Source

3. Press the **Source** soft key. The trigger source selection menu appears.
4. Use the **jog shuttle** and **SELECT** to select Line.

### Setting the Hold Off

5. Set the hold off time according to the procedures given in section 6.4.

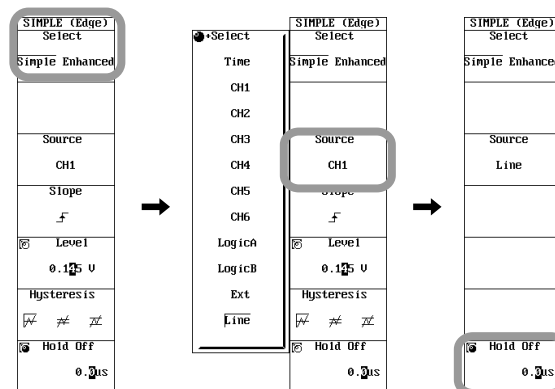

DSP1 to DSP6 are optional.

### Explanation

Triggers can be generated on the rising edge of the power signal that is being supplied to the DL750/DL750P. Waveforms can be observed by synchronizing to the commercial power supply frequency (50 Hz or 60 Hz).

### Setting the Trigger Source

Select Line. The power signal that is being supplied to the DL750/DL750P becomes the trigger source.

### Setting the Hold Off

For details, see section 6.4, "Setting the Hold Off Time."

## 6.8 Setting the Timer Trigger (SIMPLE)

<For a description of this function, refer to page 2-20.>

### Procedure

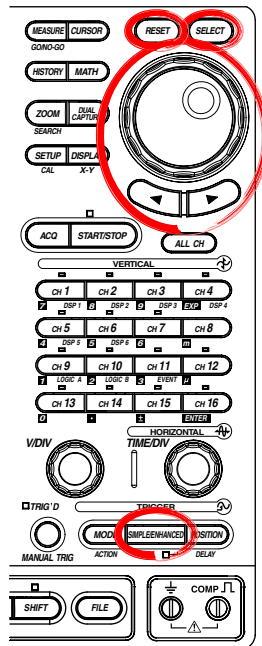

1. Press **SIMPLE/ENHANCED**.
2. Press the **Select** soft key to select Simple.

### Setting the Trigger Source

3. Press the **Source** soft key. The trigger source selection menu appears.
4. Use the **jog shuttle** and **SELECT** to select Time.

### Setting the Date/Time and the Interval for Activating Triggers

5. Press the **Date/Time** soft key. A setup dialog box opens.
6. Use the **jog shuttle** and **SELECT** to set the Date and Time.
7. When you are done, use the **jog shuttle** and **SELECT** to select Set.
8. Press the **Time Interval** soft key.
9. Turn the **jog shuttle** to set the time interval for activating triggers in the range of 1 min to 24 hours.

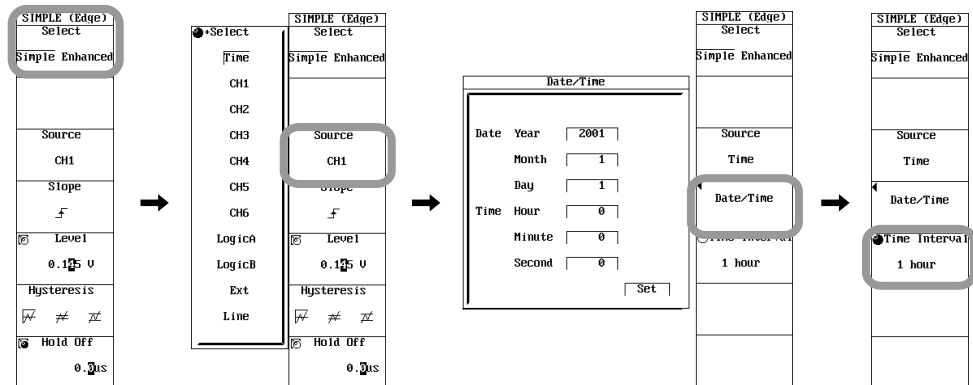

DSP1 to DSP6 are optional.

## 6.8 Setting the Timer Trigger (SIMPLE)

---

### ***Explanation***

The trigger is activated at specified time intervals from the specified time.

#### **Setting the Trigger Source**

Select Time.

#### **Setting the Reference Date and Time for Activating Triggers**

Select the date and time for activating the trigger.

#### **Setting the Time Interval for Activating Triggers**

The following intervals can be specified.

1 min, 2 min, 3 min, 4 min, 5 min, 6 min, 7 min, 8 min, 9 min, 10 min, 15 min, 20 min, 25 min, 30 min, 40 min, 45 min, 50 min, 1 hour, 2 hour, 3 hour, 4 hour, 5hour, 6 hour, 7 hour, 8 hour, 9 hour, 10 hour, 11 hour, 12 hour, 18 hour, and 24 hour

#### **Trigger Position**

Like the normal trigger, you can set the trigger position to observe the phenomenon occurring around the specified time. Initially, the trigger position is set to 50% and positioned at the center of the screen. To observe only the waveform after the trigger set the trigger position to 0%. To observe only the waveform before the trigger set it to 100%.

#### **Notes on the Timer Trigger**

- Depending on the time interval setting, a trigger may occur while the waveform is being acquired or during the pre-trigger period (a preparation period for observing the waveform before the trigger time). In such cases, the trigger is ignored.
- If the trigger time is set to a time in the past, the trigger is activated when the current time becomes  
Specified time + time interval  $\times$  N (where N is an integer).
- If you specify the acquisition count, the waveforms are acquired the specified number of times. If it is set to infinite, the waveforms are acquired until the STOP key is pressed. For the procedure in setting the acquisition count, see section 7.3.
- You can save the waveform to a floppy disk, Zip disk, PC card, or internal hard disk (optional), output the waveform on the built-in printer, and do other operations by using the action-on-trigger function.



## 6.9 Setting the Logic Trigger (SIMPLE)

<For a description of this function, refer to page 2-20.>

### Procedure

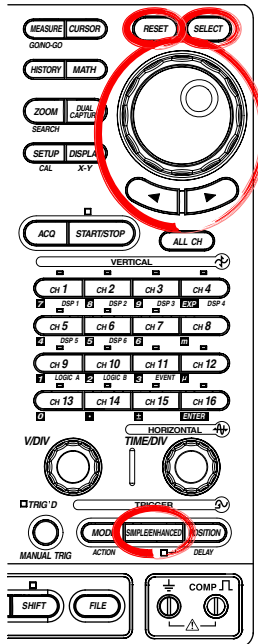

1. Press **SIMPLE/ENHANCED**.
2. Press the **Select** soft key to select Simple.

### Setting the Trigger Source

3. Press the **Source** soft key. The trigger source selection menu appears.
4. Use the **jog shuttle** and **SELECT** to select Logic A or Logic B.

### Specifying the Bit for Assigning the Trigger Slope

5. Press the **Logic Bit** soft key. The bit source selection menu appears.
6. Use the **jog shuttle** and **SELECT** to set the bit to assign the trigger slope.

### Setting the Trigger Slope

7. Press the **Slope** soft key to select  $\uparrow$  or  $\downarrow$ .

### Setting the Hold Off

8. Set the hold off time according to the procedures given in section 6.4.

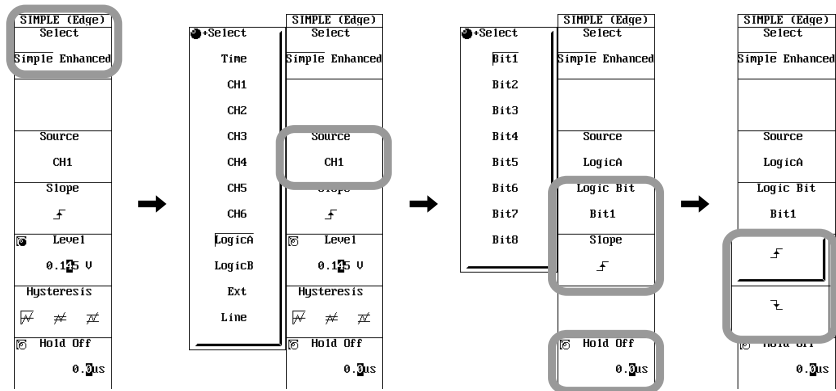

DSP1 to DSP6 are optional.

## 6.9 Setting the Logic Trigger (SIMPLE)

---

### ***Explanation***

This is the edge trigger when the trigger source is set to a logic waveform.

#### **Setting the Trigger Source**

Select Logic A or Logic B.

#### **Specifying the Bit to Assign the Trigger Slope**

Select from Bit 1 to Bit 8.

#### **Setting the Trigger Slope**

Select how the trigger source is to cross the specified level for activating the trigger from the following two choices.

- ↗: Activated when the trigger source changes from below the trigger level to above the trigger level (rising).
- ↘: Activated when the trigger source changes from above the trigger level to below the trigger level (falling).

#### **Setting the Hold Off**

For details, see section 6.4, "Setting the Hold Off Time."

# 6.10 Setting the A -> B(N) Trigger (ENHANCED)

<For a description of this function, refer to page 2-21.>

## Procedure

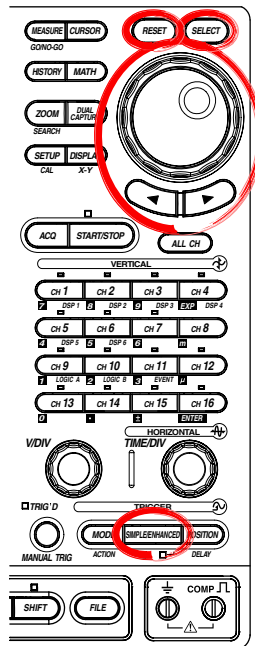

1. Press **SIMPLE/ENHANCED**.
2. Press the **Select** soft key to select Enhanced.

### Setting the Trigger Type

3. Press the **Type** soft key. The trigger type selection menu appears.
4. Use the **jog shuttle** and **SELECT** to select A -> B(N).

### Setting Condition A

5. Press the **Set Pattern** soft key. The A -> B(N) trigger setup menu appears.

#### • Setting the Condition A Pattern

6. Use the **jog shuttle** and **SELECT** to select the pattern of each channel (CH1 to CH16) from H, L, and X. For logic input channels, select Disable or Enable.

#### • Setting the Condition A Condition

7. Use the **jog shuttle** and **SELECT** to set Condition to Enter or Exit.

### Setting Condition B

8. Set the pattern and condition of condition B in a similar fashion as in steps 6 and 7.

#### • Setting the Number of Times Condition B Is to Be Met

9. Use the **jog shuttle** and **SELECT** to set Count (the number of times condition B is to be met). Pressing **RESET** resets the number to 1.

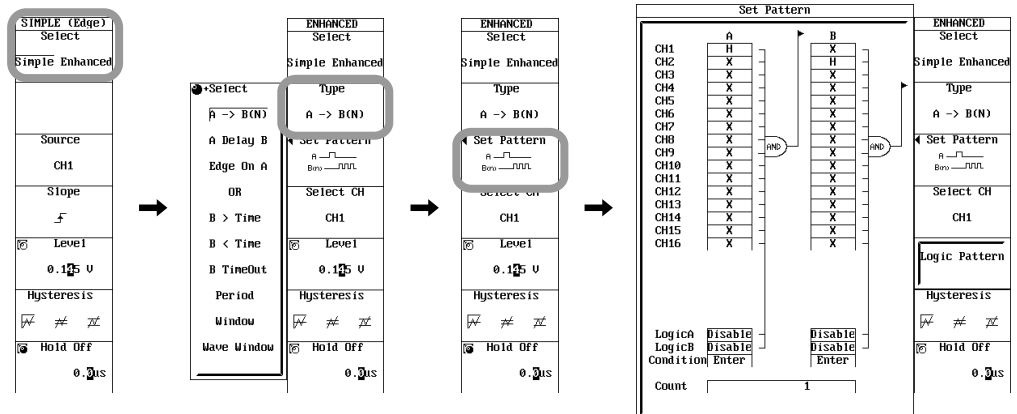

## 6.10 Setting the A -> B(N) Trigger (ENHANCED)

### Setting the Bit Patterns of Logic A and Logic B

(Only when using logic input channels)

10. Press the **Logic Pattern** soft key. The Logic Pattern setup dialog box appears.
11. Use the **jog shuttle** and **SELECT** to select the pattern of each bit (Bit A1 to Bit A8 and Bit B1 to Bit B8) from H, L, and X.

### Setting the Trigger Level

12. Press the **Select CH** soft key. The channel selection menu appears.
13. Use the **jog shuttle** and **SELECT** to set the channel to assign the trigger level.
14. Press the **Level** soft key.
15. Use the **jog shuttle** and **SELECT** to set the trigger level.
16. Likewise, set the trigger level for all channels for which patterns were assigned in steps 6 to 8.

### Note

The trigger level setting applies to both simple and enhanced triggers.

### Setting the Hysteresis

17. Press the **Hysteresis** soft key to select  $\overline{A}$ ,  $\overline{A} \neq \overline{B}$ , or  $\overline{A} \neq \overline{B}$ .

### Setting the Hold Off

18. Set the hold off time according to the procedures given in section 6.4.

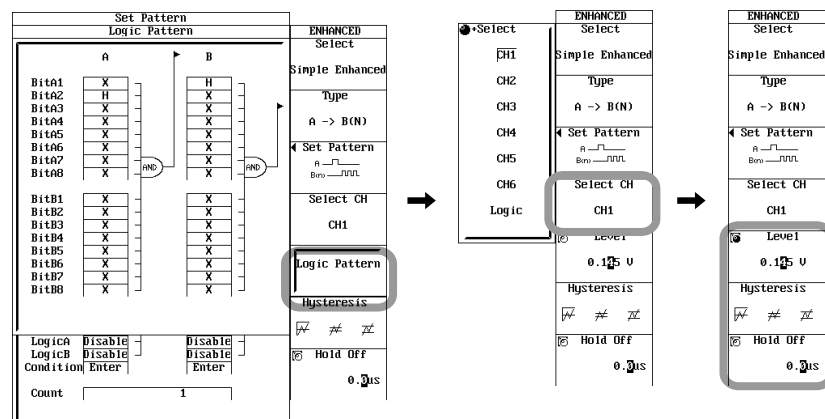

### Note

The pattern settings of conditions A and B apply to all trigger types.

**Explanation**

This function activates a trigger on the  $n^{\text{th}}$  time condition B becomes true after condition A becomes true.

**Setting Conditions A and B**

- **Pattern of Each Channel: CH1 to CH16, Logic A, and Logic B**

Select from the following:

- **For CH1 to CH16 (Other Than Logic Inputs)**

H: Above the preset trigger level

L: Below the preset trigger level

X: Don't Care

- **For Logic Input**

Enable: Make the combination of the pattern<sup>1</sup> of each bit the trigger condition

Disable: Don't Care

1. Select the pattern of each bit from the following:

H: Above a certain level<sup>2</sup>

L: Below a certain level<sup>2</sup>

X: Don't Care

2. Varies depending on the logic probe being used as follows:

700986: Approx. 1.4 V

700987: 6 V $\pm$  50% (for DC input)

700987: 50 V $\pm$  50% (for AC input)

- **Condition**

Select from the following:

Enter: A trigger is activated when all channels match the specified pattern.

Exit: A trigger is activated when any of the channels no longer match the specified pattern.

- **Number of Times Condition B Is to Be Met**

1 to 255 times

**Setting the Trigger Level**

The trigger level setting applies to both simple and enhanced triggers.

For details, see "Setting the Trigger Level" in section 6.5.

**Setting the Trigger Hysteresis**

Sets a width to the trigger level so that triggers are not activated by small changes in the trigger signal. Select the trigger hysteresis from  $\overline{A}$ ,  $\overline{A}/$ , and  $\overline{A}/\overline{V}$ .

For details, see "Setting the Trigger Hysteresis" in section 6.5.

**Setting the Hold Off**

For details, see section 6.4, "Setting the Hold Off Time."

**Note**

- If you wish to use a simple pattern trigger (only one pattern condition for activating the trigger), set all of the status of condition B to Xs (Don't care) and set a pattern for condition A.
- If you wish to set the trigger only on the condition of the pattern of each bit of the logic input (trigger on the AND of each bit), then make the following settings.
 

Condition A pattern:	Set the logic input channels to be used to Enable, All other channels to X (Don't care)
Condition B pattern:	All Xs (Don't Care)
Bit pattern of logic input:	Set arbitrarily.

# 6.11 Setting the A Delay B Trigger (ENHANCED)

<For a description of this function, refer to page 2-21.>

## Procedure

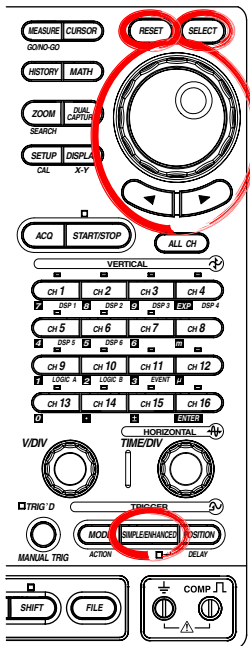

1. Press **SIMPLE/ENHANCED**.
2. Press the **Select** soft key to select Enhanced.

### Setting the Trigger Type

3. Press the **Type** soft key. The trigger type selection menu appears.
4. Use the **jog shuttle** and **SELECT** to select A Delay B.

### Setting Condition A

5. Press the **Set Pattern** soft key. The A Delay B trigger setup menu appears.

#### • Setting the Condition A Pattern

6. Use the **jog shuttle** and **SELECT** to select the pattern of each channel (CH1 to CH16) from H, L, and X. For logic input channels, select Disable or Enable.

#### • Setting the Condition A Condition

7. Use the **jog shuttle** and **SELECT** to set Condition to Enter or Exit.

### Setting Condition B

8. Set the pattern and condition of condition B in a similar fashion as in steps 6 and 7.

### Setting the Delay Time

9. Use the **jog shuttle** and **SELECT** to set Delay. Pressing **RESET** resets the value to 0.0  $\mu$ s.

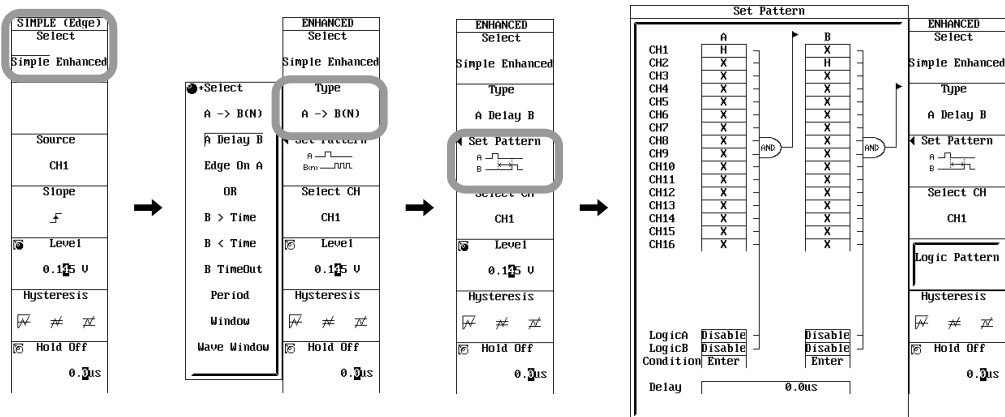

**Setting the Bit Patterns of LOGIC A and LOGIC B**

(Only when using logic input channels)

10. Press the **Logic Pattern** soft key. The Logic Pattern setup dialog box appears.
11. Use the **jog shuttle** and **SELECT** to select the pattern of each bit (Bit A1 to Bit A8 and Bit B1 to Bit B8) from H, L, and X.

**Setting the Trigger Level**

12. Press the **Select CH** soft key. The channel selection menu appears.
13. Use the **jog shuttle** and **SELECT** to set the channel to assign the trigger level.
14. Press the **Level** soft key.
15. Use the **jog shuttle** and **SELECT** to set the trigger level.
16. Likewise, set the trigger level for all channels for which patterns were assigned in steps 6 to 8.

**Note**

---

The trigger level setting applies to both simple and enhanced triggers.

---

**Setting the Hysteresis**

17. Press the **Hysteresis** soft key to select  $\overline{A}$ ,  $\overline{B}$ , or  $\overline{A \& B}$ .

**Setting the Hold Off**

18. Set the hold off time according to the procedures given in section 6.4.

**Note**

---

The pattern settings of conditions A and B apply to all trigger types.

---

## 6.11 Setting the A Delay B Trigger (ENHANCED)

---

### Explanation

This function activates a trigger the first time condition B becomes true after condition A has become true and the preset time has elapsed.

#### Setting Conditions A and B

- **Pattern of Each Channel: CH1 to CH16, Logic A, and Logic B**

Select from the following:

- **CH1 to CH16 (Other Than Logic Inputs)**

H: Above the preset trigger level

L: Below the preset trigger level

X: Don't Care

- **Logic Input**

Enable: Make the combination of the pattern<sup>1</sup> of each bit the trigger condition

Disable: Don't Care

1. Select the pattern of each bit from the following:

H: Above a certain level<sup>2</sup>

L: Below a certain level<sup>2</sup>

X: Don't Care

2. Varies depending on the logic probe being used as follows:

700986: Approx. 1.4 V

700987: 6 V±50% (for DC input)

700987: 50 V± 50% (for AC input)

- **Condition**

Select from the following:

Enter: A trigger is activated when all channels match the specified pattern.

Exit: A trigger is activated when any of the channels no longer match the specified pattern.

- **Delay**

0 to 10 s (resolution is 100 ns)

#### Setting the Trigger Level

The trigger level setting applies to both simple and enhanced triggers.

For details, see "Setting the Trigger Level" in section 6.5.

#### Setting the Trigger Hysteresis

Sets a width to the trigger level so that triggers are not activated by small changes in the trigger signal. Select the trigger hysteresis from  $\nabla$ ,  $\nabla$ , and  $\nabla$ .

For details, see "Setting the Trigger Hysteresis" in section 6.5.

#### Setting the Hold Off

For details, see section 6.4, "Setting the Hold Off Time."

#### Note

---

If you want to activate only one pattern trigger, use the A -> B(n) trigger function (see section 6.10).

---



# 6.12 Setting the Edge on A Trigger (ENHANCED)

<For a description of this function, refer to page 2-22.>

## Procedure

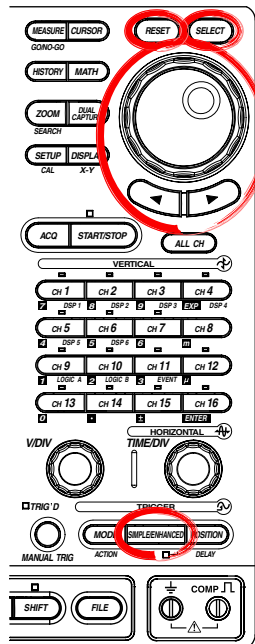

1. Press **SIMPLE/ENHANCED**.
2. Press the **Select** soft key to select Enhanced.

### Setting the Trigger Type

3. Press the **Type** soft key. The trigger type selection menu appears.
4. Use the **jog shuttle** and **SELECT** to select Edge on A.

### Setting Condition A

5. Press the **Set Pattern** soft key. The Edge on A trigger setup menu appears.

#### • Setting the Condition A Pattern

6. Use the **jog shuttle** and **SELECT** to select the pattern of each channel (CH1 to CH16) from H, L, and X. For logic input channels, select Disable or Enable.

#### • Setting the Condition A Condition

7. Use the **jog shuttle** and **SELECT** to set Condition to True or False.

### Setting the Edge Trigger OR

8. Use the **jog shuttle** and **SELECT** to select the edge trigger OR status of each channel (CH1 to CH16) from  $\uparrow$ ,  $\downarrow$ , and  $\neg$ . For logic input channels, select Disable or Enable.

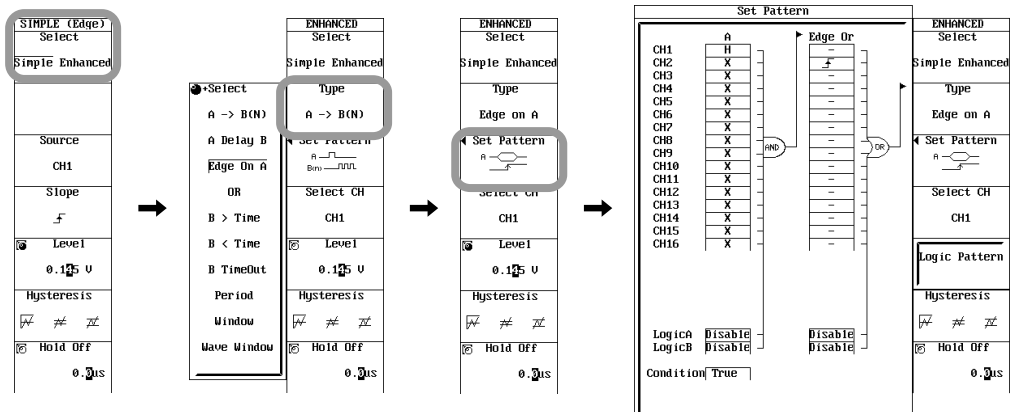

## 6.12 Setting the Edge on A Trigger (ENHANCED)

### Setting the Bit Patterns/Status of LOGIC A and LOGIC B

#### (Only When Using Logic Input Channels)

9. Press the **Logic Pattern** soft key. The Logic Pattern setup dialog box appears.
10. Use the **jog shuttle** and **SELECT** to select the pattern of each bit (Bit A1 to Bit A8 and Bit B1 to Bit B8) of condition A from H, L, and X.
11. Likewise, use the **jog shuttle** and **SELECT** to select the edge trigger OR status from  $\uparrow$ ,  $\downarrow$ , and  $\neg$ .

### Setting the Trigger Level

12. Press the **Select CH** soft key. The channel selection menu appears.
13. Use the **jog shuttle** and **SELECT** to set the channel to assign the trigger level.
14. Press the **Level** soft key.
15. Use the **jog shuttle** and **SELECT** to set the trigger level.
16. Likewise, set the trigger level for all channels for which patterns were assigned in steps 5 to 6.

#### Note

The trigger level setting applies to both simple and enhanced triggers.

### Setting the Hysteresis

17. Press the **Hysteresis** soft key to select  $\nabla$ ,  $\nabla$ , or  $\nabla$ .

### Setting the Hold Off

18. Set the hold off time according to the procedures given in section 6.4.

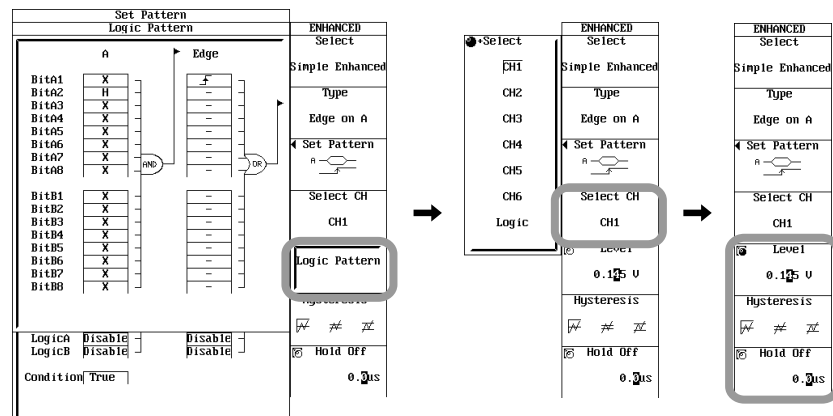

#### Note

The pattern settings of condition A apply to all trigger types.

**Explanation**

This function activates a trigger on the OR logic of the edge trigger of each channel while condition A is true.

**Setting Conditions A/Edge Or**

- **Pattern of Each Channel of Condition A: CH1 to CH16, Logic A, and Logic B**

Select from the following:

- **CH1 to CH16 (Other Than Logic Inputs)**

H: Above the preset trigger level

L: Below the preset trigger level

X: Don't Care

- **Logic Input**

Enable: Make the combination of the pattern<sup>1</sup> of each bit the trigger condition

Disable: Don't Care

1. Select the pattern of each bit from the following:

H: Above a certain level<sup>2</sup>

L: Below a certain level<sup>2</sup>

X: Don't Care

2. Varies depending on the logic probe being used as follows:

700986: Approx. 1.4 V

700987: 6 V $\pm$  50% (for DC input)

700987: 50 V $\pm$  50% (for AC input)

- **Condition**

Select from the following:

True: A trigger is activated while all channels match the specified pattern.

False: A trigger is activated while any of the channels do not match the specified pattern.

- **Edge Trigger of Each Channel**

This setting is possible only if the channel's condition A pattern is set to X (Don't Care). If you set all condition A patterns to X (Don't Care), the trigger will operate as an OR trigger.

- **CH1 to CH16 (Other Than Logic Inputs)**

↗: Rising edge

↘: Falling edge

—: Don't Care

- **Logic Input**

Enable: Make the combination of the pattern<sup>1</sup> of each bit the trigger condition

Disable: Don't Care

1. Select the pattern of each bit from the following:

↗: When the signal goes above a certain level<sup>2</sup>

↘: When the signal goes below a certain level<sup>2</sup>

—: Don't Care

2. Varies depending on the logic probe being used as follows:

700986: Approx. 1.4 V

700987: 6 V $\pm$  50% (for DC input)

700987: 50 V $\pm$  50% (for AC input)

## 6.12 Setting the Edge on A Trigger (ENHANCED)

---

### **Setting the Trigger Level**

The trigger level setting applies to both simple and enhanced triggers. For details, see “Setting the Trigger Level” in section 6.5.

### **Setting the Trigger Hysteresis**

Sets a width to the trigger level so that triggers are not activated by small changes in the trigger signal. Select the trigger hysteresis from  $\overline{A}$ ,  $\overline{A}$ , and  $\overline{A}$ . For details, see “Setting the Trigger Hysteresis” in section 6.5.

### **Setting the Hold Off**

For details, see section 6.4, “Setting the Hold Off Time.”

# 6.13 Setting the OR Trigger (ENHANCED)

<For a description of this function, refer to page 2-22.>

## Procedure

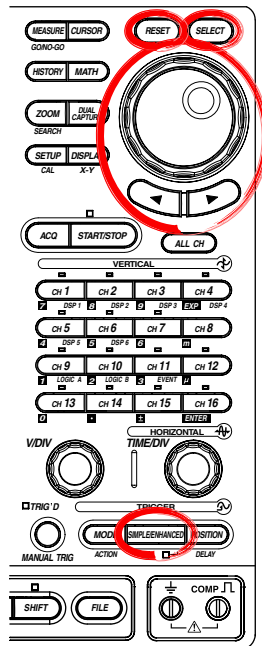

1. Press **SIMPLE/ENHANCED**.
2. Press the **Select** soft key to select Enhanced.

### Setting the Trigger Type

3. Press the **Type** soft key. The trigger type selection menu appears.
4. Use the **jog shuttle** and **SELECT** to select OR.

### Setting the Edge Trigger OR

5. Press the **Set Pattern** soft key. The OR trigger setup menu appears.
6. Use the **jog shuttle** and **SELECT** to select the edge trigger OR status of each channel (CH1 to CH16, DSP1 to DSP6 (optional)) from  $\uparrow$ ,  $\downarrow$ , and  $\text{---}$ . For logic input channels, select Disable or Enable.

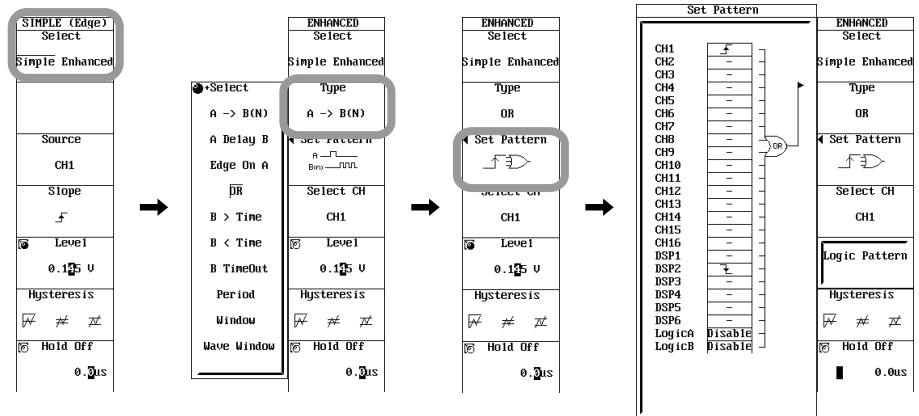

## 6.13 Setting the OR Trigger (ENHANCED)

### Setting the Status of Each Bit of Logic A and Logic B

#### (Only When Using Logic Input Channels)

7. Press the **Logic Pattern** soft key. The Logic Pattern setup dialog box appears.
8. Use the **jog shuttle** and **SELECT** to select the edge trigger OR status of each bit (Bit A1 to Bit A8 and Bit B1 to Bit B8) from  $\uparrow$ ,  $\downarrow$ , and  $\text{--}$ .

### Setting the Trigger Level

9. Press the **Select CH** soft key. The channel selection menu appears.
10. Use the **jog shuttle** and **SELECT** to set the channel to assign the trigger level.
11. Press the **Level** soft key.
12. Use the **jog shuttle** and **SELECT** to set the trigger level.
13. Likewise, set the trigger level for all channels for which patterns were assigned in step 6.

### Note

The trigger level setting applies to both simple and enhanced triggers.

### Setting the Hysteresis

14. Press the **Hysteresis** soft key to select  $\uparrow\downarrow$ ,  $\uparrow\neq$ , or  $\uparrow\downarrow$ .

### Setting the Hold Off

15. Set the hold off time according to the procedures given in section 6.4.

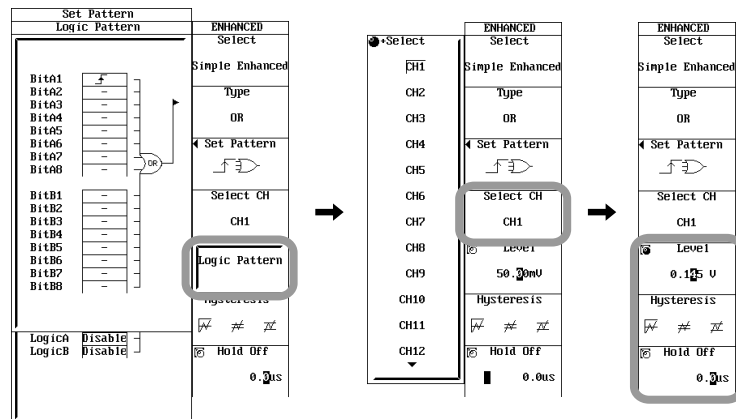

**Explanation**

This function activates a trigger on the OR logic of edge triggers. You can set trigger conditions on all channels (CH1 to CH16) and DSP channels (DSP1 to DSP6 (option)). For example, a trigger can be activated on the rising edge of CH1 or CH2.

**Setting the Edge Trigger of Each Channel**

Select from the following:

- **CH1 to CH16 (Other Than Logic Inputs) or DSP1 to DSP6 (optional)**

┆ : Rising edge

┆ : Falling edge

—: Don't Care

- **Logic Input**

Enable: Make the combination of the status<sup>1</sup> of each bit the trigger condition

Disable: Don't Care

1. Select the status of each bit from the following:

┆ : When the signal goes above a certain level<sup>2</sup>

┆ : When the signal goes below a certain level<sup>2</sup>

—: Don't Care

2. Varies depending on the logic probe being used as follows:

700986: Approx. 1.4 V

700987: 6 V±50% (for DC input)

700987: 50 V± 50% (for AC input)

**Setting the Trigger Level**

The trigger level setting applies to both simple and enhanced triggers.

For details, see "Setting the Trigger Level" in section 6.5.

**Setting the Trigger Hysteresis**

Sets a width to the trigger level so that triggers are not activated by small changes in the trigger signal. Select the trigger hysteresis from  $\nabla$ ,  $\neq$ , and  $\nabla$ .

For details, see "Setting the Trigger Hysteresis" in section 6.5.

**Setting the Hold Off**

For details, see section 6.4, "Setting the Hold Off Time."

**Note**

The OR trigger is equivalent to setting the pattern of condition A of Edge on A trigger to all Xs (Don't Care).

# 6.14 Setting the B > Time, B < Time, or B TimeOut (Pulse Width) Trigger (ENHANCED)

<For a description of this function, refer to page 2-23.>

## Procedure

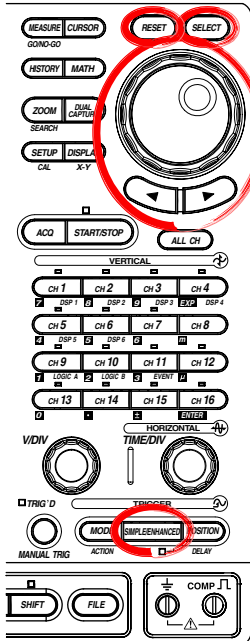

1. Press **SIMPLE/ENHANCED**.
2. Press the **Select** soft key to select Enhanced.

### Setting the Trigger Type

3. Press the **Type** soft key. The trigger type selection menu appears.
4. Use the **jog shuttle** and **SELECT** to select B > Time, B < Time, or B TimeOut.

### Setting the Condition B Pattern

5. Press the **Set Pattern** soft key. The B > Time trigger, B < Time trigger, and B TimeOut trigger setup menu appears.
6. Use the **jog shuttle** and **SELECT** to select the pattern of each channel (CH1 to CH16) from H, L, and X. For logic input channels, select Disable or Enable.

### Setting the Pulse Width

7. Use the **jog shuttle** and **SELECT** to set Time. Pressing **RESET** resets the value to 0.1  $\mu$ s.

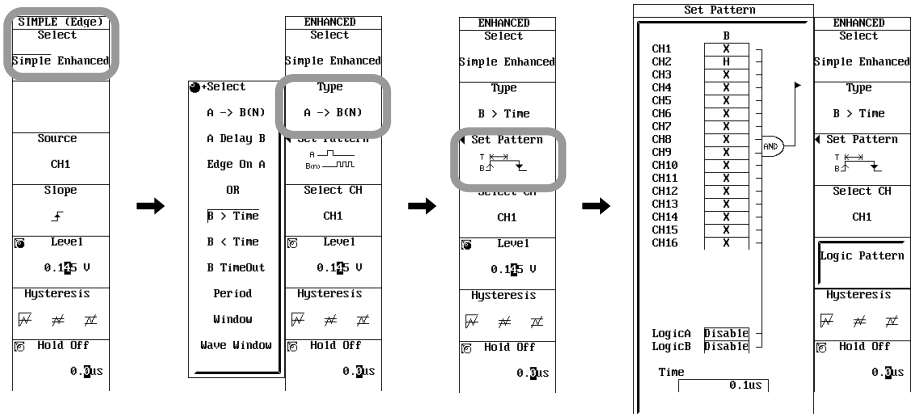



## 6.14 Setting the B > Time, B < Time, or B TimeOut (Pulse Width) Trigger (ENHANCED)

### Setting the Bit Patterns of LOGIC A and LOGIC B

#### (Only When Using Logic Input Channels)

8. Press the **Logic Pattern** soft key. The Logic Pattern setup dialog box appears.
9. Use the **jog shuttle** and **SELECT** to select the pattern of each bit (Bit A1 to Bit A8 and Bit B1 to Bit B8) from H, L, and X.

### Setting the Trigger Level

10. Press the **Select CH** soft key. The channel selection menu appears.
11. Use the **jog shuttle** and **SELECT** to set the channel to assign the trigger level.
12. Press the **Level** soft key.
13. Use the **jog shuttle** and **SELECT** to set the trigger level.
14. Likewise, set the trigger level for all channels for which patterns were assigned in step 6.

#### Note

The trigger level setting applies to both simple and enhanced triggers.

### Setting the Hysteresis

15. Press the **Hysteresis** soft key to select  $\overline{V}$ ,  $\overline{\neq}$ , or  $\overline{\nabla}$ .

### Setting the Hold Off

16. Set the hold off time according to the procedures given in section 6.4.

#### Note

The pattern settings of condition B apply to all trigger types.

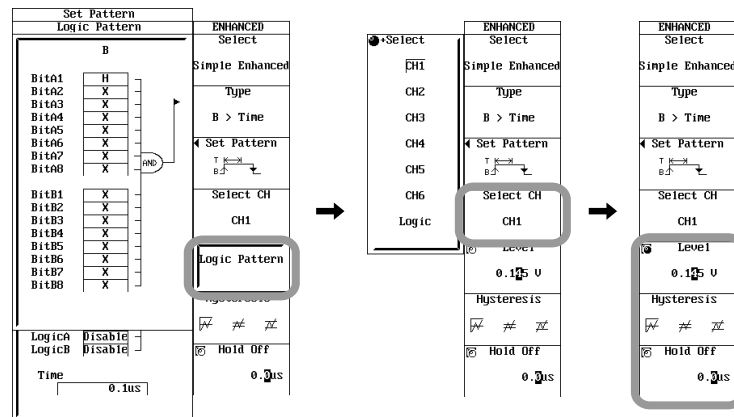

**6.14 Setting the B > Time, B < Time, or B TimeOut (Pulse Width) Trigger (ENHANCED)**

**Explanation**

The following three pulse width triggers are available.

**B > Time:** A trigger is activated when condition B goes false after holding true for the preset pulse width.

**B < Time:** A trigger is activated when condition B goes false after holding true for less than the preset pulse width.

**B Time Out:** A trigger is activated when condition B has held true for the preset pulse width.

The point where the trigger occurs differs between B > Time and B Time Out as shown in the figure below.

**When B > Time, CH1 = H, and Time = 4 μs**

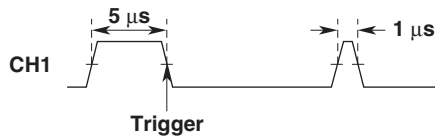

**When B Time Out, CH1 = H, and Time = 4 μs**

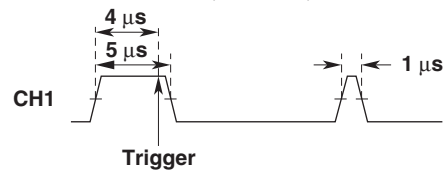

**B < Time Setup Example**

**When B < Time, condition B: CH1 = H, CH2 = H, and Time = 4 μs**

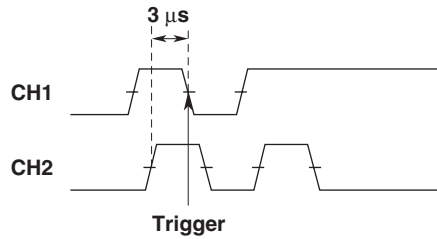

CH1	L	H	L	H
CH2	L	H	L	H

$3 \mu s$        $5 \mu s$

### Setting Condition B

- **Pattern of Each Channel: CH1 to CH16, Logic A, and Logic B**

Select from the following:

- **CH1 to CH16 (Other Than Logic Inputs)**

H: Above the preset trigger level

L: Below the preset trigger level

X: Don't Care

- **Logic Input**

Enable: Make the combination of the pattern<sup>1</sup> of each bit the trigger condition

Disable: Don't Care

1. Select the pattern of each pattern from the following:

H: Above a certain level<sup>2</sup>

L: Below a certain level<sup>2</sup>

X: Don't Care

2. Varies depending on the logic probe being used as follows:

700986: Approx. 1.4 V

700987: 6 V ± 50% (for DC input)

700987: 50 V ± 50% (for AC input)

### Setting the Pulse Width

100 ns to 10 s (resolution is 100 ns)

### Notes When Setting the B>Time, B<Time, or B Time Out Trigger

- Correct operation is not guaranteed if adjacent pulses are less than 100 ns apart or if the pulse width is less than 100 ns (typical).



### Setting the Trigger Level

The trigger level setting applies to both simple and enhanced triggers.

For details, see "Setting the Trigger Level" in section 6.5.

### Setting the Trigger Hysteresis

Sets a width to the trigger level so that triggers are not activated by small changes in the trigger signal. Select the trigger hysteresis from  $\nabla$ ,  $\neq$ , and  $\nabla$ .

For details, see "Setting the Trigger Hysteresis" in section 6.5.

### Setting the Hold Off

For details, see section 6.4, "Setting the Hold Off Time."

# 6.15 Setting the Period Trigger (ENHANCED)

<For a description of this function, refer to page 2-24.>

## Procedure

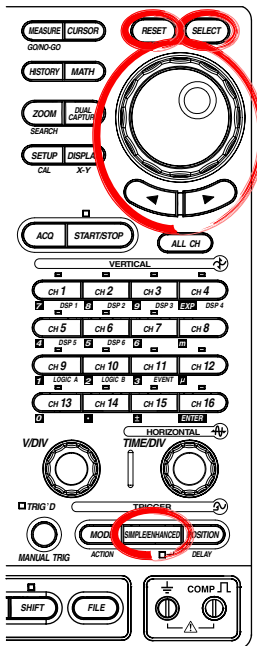

1. Press **SIMPLE/ENHANCED**.
2. Press the **Select** soft key to select Enhanced.

### Setting the Trigger Type

3. Press the **Type** soft key. The trigger type selection menu appears.
4. Use the **jog shuttle** and **SELECT** to select Period.

### Setting the Condition B Status

5. Press the **Set Pattern** soft key. The Period trigger setup menu appears.
6. Press the **Mode** soft key and use the **jog shuttle** and **SELECT** to select T > Time, T < Time, T1 < T2, or T < T1, T2 < T.
7. Use the **jog shuttle** and **SELECT** to select the pattern of each channel (CH1 to CH16) from H, L, and X. For logic input channels, select Disable or Enable.

### Setting the Time of Satisfaction

- **For T > Time or T < Time**
  8. Use the **jog shuttle** and **SELECT** to set Time. Pressing **RESET** resets the value to 0.1  $\mu$ s.
- **For T1 < T2 or T < T1, T2 < T**
  8. Use the **jog shuttle** and **SELECT** to set Time1 and Time2. Pressing **RESET** resets Time1 to 0.1  $\mu$ s and Time2 to 0.2  $\mu$ s.

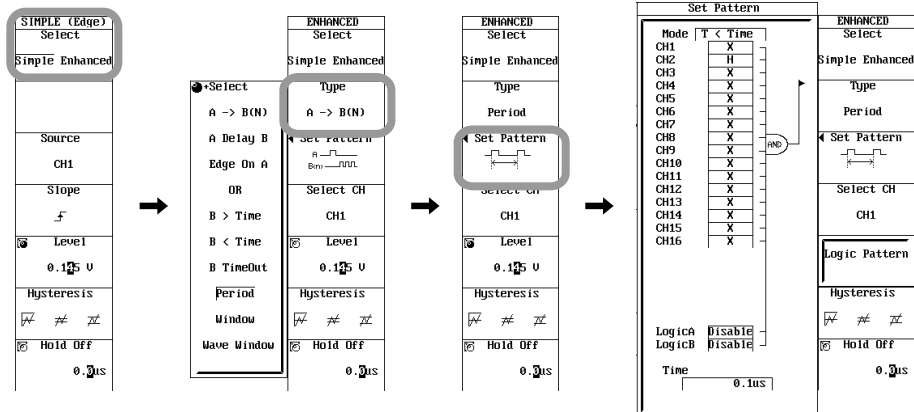

**Setting the Bit Patterns of LOGIC A and LOGIC B****(Only When Using Logic Input Channels)**

9. Press the **Logic Pattern** soft key. The Logic Pattern setup dialog box appears.
10. Use the **jog shuttle** and **SELECT** to select the pattern of each bit (Bit A1 to Bit A8 and Bit B1 to Bit B8) from H, L, and X.

**Setting the Trigger Level**

11. Press the **Select CH** soft key. The channel selection menu appears.
12. Use the **jog shuttle** and **SELECT** to set the channel to assign the trigger level.
13. Press the **Level** soft key.
14. Use the **jog shuttle** and **SELECT** to set the trigger level.
15. Likewise, set the trigger level for all channels for which patterns were assigned in step 7.

**Note**

The trigger level setting applies to both simple and enhanced triggers.

**Setting the Hysteresis**

16. Press the **Hysteresis** soft key to select  $\overline{A}$ ,  $\overline{B}$ , or  $\overline{A \& B}$ .

**Note**

The pattern settings of condition B apply to all trigger types.

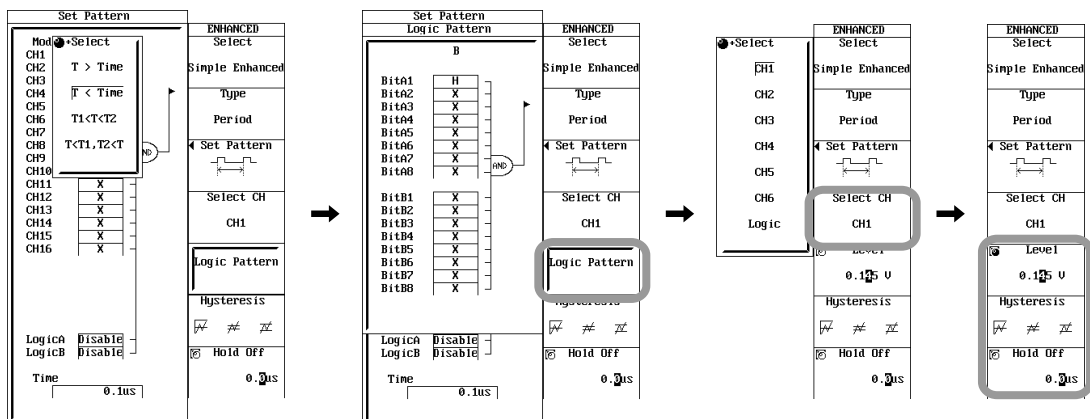

## 6.15 Setting the Period Trigger (ENHANCED)

---

### Explanation

The following four period triggers are available.

- T > Time: A trigger is activated when condition B is met the second time, if the time when condition B is met the second time is longer than a specified time.
- T < Time: A trigger is activated when condition B is met the second time, if the time when condition B is met the second time is shorter than a specified time.
- T1 < T < T2: A trigger is activated when condition B is met the second time, if the time when condition B is met the second time is within a specified time range.
- T < T1, T2 < T: A trigger is activated when condition B is met the second time, if the time when condition B is met the second time is outside a specified time range.

### Setting Condition B

- **Pattern of Each Channel: CH1 to CH16, Logic A, and Logic B**

Select from the following:

- **CH1 to CH16 (Other Than Logic Inputs)**

H: Above the preset trigger level

L: Below the preset trigger level

X: Don't Care

- **Logic Input**

Enable: Make the combination of the pattern<sup>1</sup> of each bit the trigger condition

Disable: Don't Care

1. Select the pattern of each pattern from the following:

H: Above a certain level<sup>2</sup>

L: Below a certain level<sup>2</sup>

X: Don't Care

2. Varies depending on the logic probe being used as follows:

700986: Approx. 1.4 V

700987: 6 V ± 50% (for DC input)

700987: 50 V ± 50% (for AC input)

- **Setting the Time of Satisfaction**

- **For T > Time or T < Time**

Time: 0.1 μs to 9999999.9 μs

- **For T1 < T < T2 or T < T1, T2 < T**

Time1: 0.1 μs to 9999999.9 μs

Time2: 0.2 μs to 10000000.0 μs

### Setting the Trigger Level

The trigger level setting applies to both simple and enhanced triggers.

For details, see "Setting the Trigger Level" in section 6.5.

### Setting the Trigger Hysteresis

Sets a width to the trigger level so that triggers are not activated by small changes in the trigger signal. Select the trigger hysteresis from  $\overline{A}$ ,  $\overline{A}$ , and  $\overline{\overline{A}}$ .

For details, see "Setting the Trigger Hysteresis" in section 6.5.

# 6.16 Setting the Window Trigger (ENHANCED)

<For a description of this function, refer to page 2-25.>

## Procedure

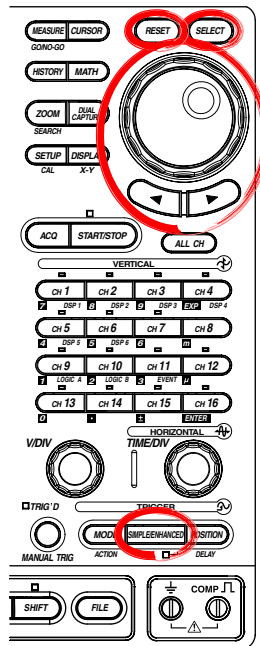

1. Press **SIMPLE/ENHANCED**.
2. Press the **Select** soft key to select Enhanced.

### Setting the Trigger Type

3. Press the **Type** soft key. The trigger type selection menu appears.
4. Use the **jog shuttle** and **SELECT** to select Window.

### Set the Trigger Condition

5. Press the **Set Pattern** soft key. The Window trigger setup menu appears.
6. Use the **jog shuttle** and **SELECT** to select the pattern of each channel (CH1 to CH16, DSP1 to DSP6 (optional)) from IN, OUT, and -. For logic input channels, select Disable or Enable.

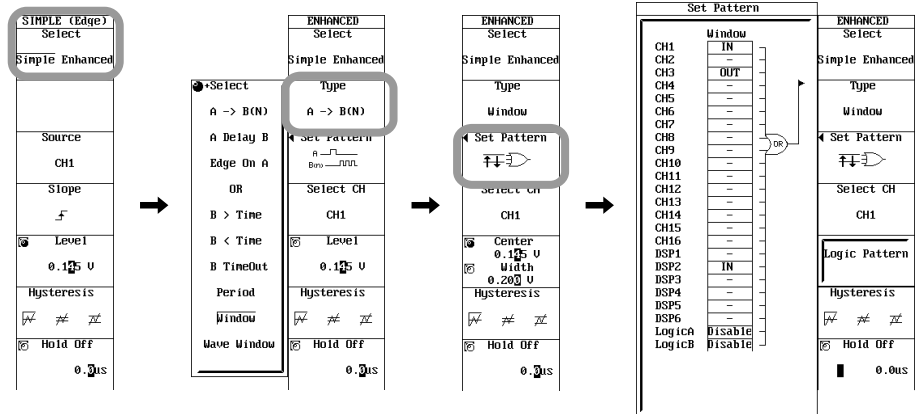

## 6.16 Setting the Window Trigger (ENHANCED)

### Setting the Status of Each Bit of LOGIC A and LOGIC B

#### (Only When Using Logic Input Channels)

7. Press the **Logic Pattern** soft key. The Logic Pattern setup dialog box appears.
8. Use the **jog shuttle** and **SELECT** to select the status of each bit (Bit A1 to Bit A8 and Bit B1 to Bit B8) from  $f$ ,  $\bar{f}$ , and  $-$ .

### Selecting the Target Waveform

9. Press the **Select CH** soft key. The channel selection menu appears.
10. Use the **jog shuttle** and **SELECT** to select the target channel.

### Setting the Window (When the Target Waveform Is Not LOGIC)

#### • Setting the Center Level

11. Press the **Center/Width** soft key to set the jog shuttle control to Center.
12. Turn the **jog shuttle** to set the center level.

#### • Setting the Window Width

13. Press the **Center/Width** soft key to set the jog shuttle control to Width.
14. Turn the **jog shuttle** to set the window width.

### Setting the Hysteresis

15. Press the **Hysteresis** soft key to select  $\nabla$ ,  $\nabla$ , or  $\nabla$ s.

### Setting the Hold Off

16. Set the hold off time according to the procedures given in section 6.4.

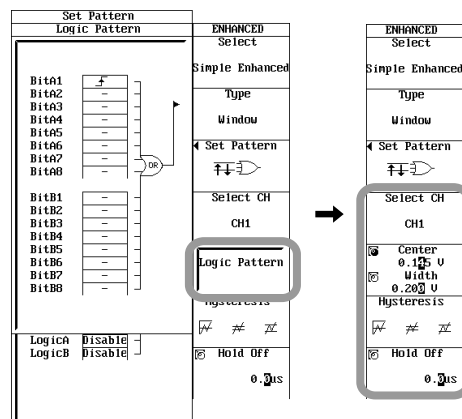



**Explanation****Window Trigger Target**

You can set trigger conditions on all channels (CH1 to CH16) other than logic waveforms and DSP channels (DSP1 to DSP6 (option)). A trigger occurs if any of the specified trigger conditions (OR condition) is met.

**Selecting the Trigger Condition**

- **CH1 to CH16 (Other Than Logic Inputs) or DSP1 to DSP6 (optional)**

IN: A trigger is activated when the trigger source enters the window (the area between two preset levels).

OUT: A trigger is activated when the trigger source exits the window.

- **Logic Input**

Enable: Make the combination of the status<sup>1</sup> of each bit the trigger condition

Disable: Don't Care

1. Select the status of each bit from the following:

┐: When the signal goes above a certain level<sup>2</sup>

┘: When the signal goes below a certain level<sup>2</sup>

–: Don't Care

2. Varies depending on the logic probe being used as follows:

700986: Approx. 1.4 V

700987: 6 V ± 50% (for DC input)

700987: 50 V ± 50% (for AC input)

**Setting the Window**

A window is defined by its center level and width.

Selectable range of Center:  $\pm(V/\text{div}) \times 10$  when measuring voltage, measurement range of the thermocouple when measuring temperature (Resolution: Same as the resolution of the trigger level. See section 6.5.)

Selectable range of Width:  $\pm(V/\text{div}) \times 10$  when measuring voltage, measurement range of the thermocouple when measuring temperature around the center level (Resolution: Same as the resolution of the trigger level. See section 6.5.)

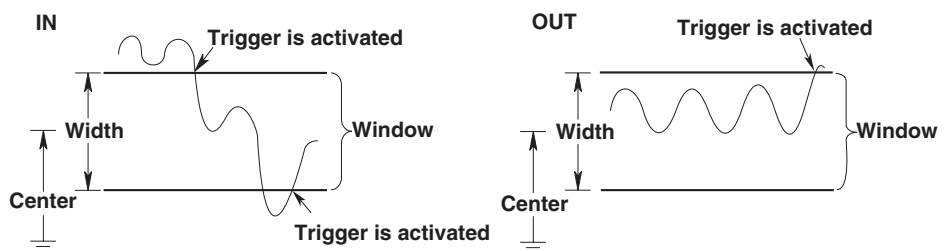
**Setting the Trigger Hysteresis**

Sets a width to the trigger level so that triggers are not activated by small changes in the trigger signal. Select the trigger hysteresis from , , and .

For details, see "Setting the Trigger Hysteresis" in section 6.5.

**Setting the Hold Off**

For details, see section 6.4, "Setting the Hold Off Time."

**Notes When Activating Window Triggers**

The operation is the same as the OR trigger for logic input.

# 6.17 Setting the Wave Window Trigger (ENHANCED)

<For a description of this function, refer to page 2-26.>

## Procedure

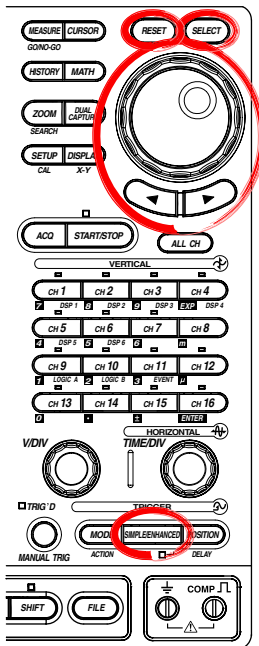

1. Press **SIMPLE/ENHANCED**.
2. Press the **Select** soft key to select Enhanced.

### Setting the Trigger Type

3. Press the **Type** soft key. The trigger type selection menu appears.
4. Use the **jog shuttle** and **SELECT** to select Wave Window.

### Setting the Trigger Condition

5. Press the **Set Pattern** soft key. The Wave Window trigger setup menu appears.
6. Use the **jog shuttle** and **SELECT** to select the pattern of each channel (CH1 to CH16) from ON and OFF.

### Note

- The wave window trigger does not apply to the 701265 (TEMP/HPV) and the 701280 (FREQ).
- Wave window trigger is not applicable when measuring temperature on the 701261 (UNIVERSAL) or 701262 (UNIVERSAL (AAF)).
- Wave window trigger cannot be used in the recorder mode.

### Setting the Cycle Frequency, Reference Cycle, Synchronization Channel, Level, and Hysteresis

7. Use the **jog shuttle**, **SELECT**, and **jog shuttle** to set the Cycle Frequency. Pressing **RESET** resets the frequency to 50 Hz.
8. Likewise, set the Reference Cycle to 1, 2, or 4.
9. Likewise, set Sync. Ch to Auto or CH1 to CH16.
10. If a setting other than Auto was selected in step 9, set the Level of the synchronization channel.
11. Likewise, set Hys to  $\sqrt{\text{V}}$ ,  $\sqrt{\text{A}}$ , or  $\sqrt{\text{V}}$ .

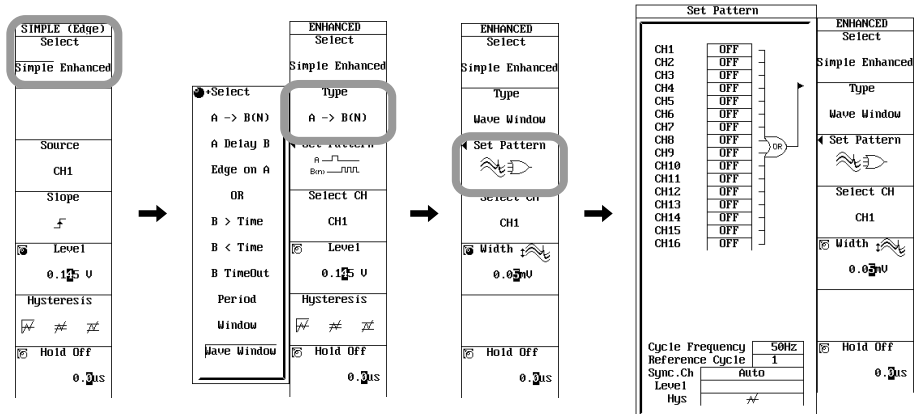

**Selecting the Target Waveform**

12. Press the **Select CH** soft key. The channel selection menu appears.
13. Use the **jog shuttle** and **SELECT** to select the target channel.

**Setting the Window Width**

14. Press the **Width** soft key.
15. Turn the **jog shuttle** to set the window width.

**Setting the Hold Off**

16. Set the hold off time according to the procedures given in section 6.4.

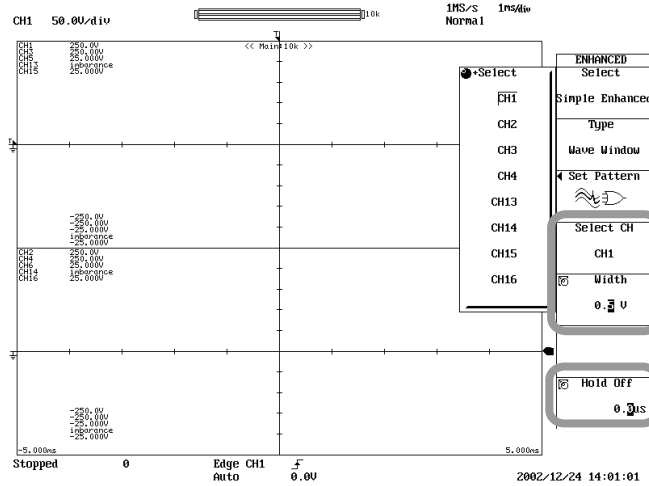

**Explanation**

This trigger is used to detect abnormalities in the power waveform (disruption, sag, surge, frequency fluctuation, voltage drop, etc.). A realtime template is continuously created automatically using 1 to 4 waveforms before the current waveform, and comparison is made between the current waveform and the realtime template. A trigger occurs if the current waveform falls outside the realtime template.

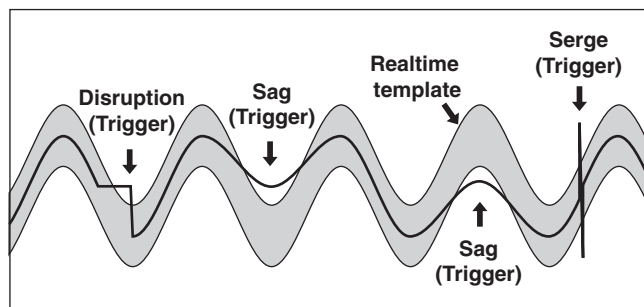
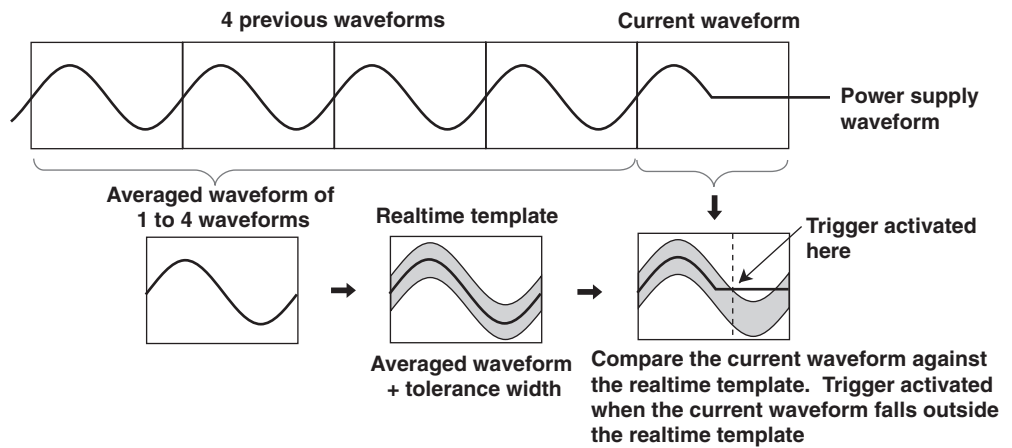

## 6.17 Setting the Wave Window Trigger (ENHANCED)

### Operating Conditions of the Wave Window Trigger

Target waveform: AC waveform or triangular waveform between 40 and 1 kHz.  
(Rectangular waveforms such as inverter waveforms and waveforms with a fast rising edge are excluded)

Sample rate: 10 kS/s to 500 kS/s

Acquisition mode: Normal

Trigger mode: Normal, Single, or Single(N)

### Applicable Modules

- 701250 (HS10M12)
- 701251 (HS1M16)
- 701255 (NONISO\_10M12)
- 701260 (HV(with RMS))
- 701261 (UNIVERSAL) (only when measuring voltage)
- 701262 (UNIVERSAL (AAF)) (only when measuring voltage)
- 701270 (STRAIN\_NDIS)
- 701271 (STRAIN\_DSUB)
- 701275 (ACCL/VOLT)

A trigger occurs if any of the specified trigger conditions (OR condition) is met.

### Notes When Using the Wave Window Trigger

The wave window trigger cannot be used in the following cases:

- When the dual capture function is ON.
- When the acquisition mode is set to Average or Envelope
- When the record length is less than or equal to 25 kW and T/div is less than 10 mS/div.

Wave window triggers are not easily triggered when the trigger mode is set to Auto or Auto Level.

Normally, set the trigger mode to Normal, Single, or Single(N).

The wave window trigger is used to detect rapid changes in the waveform. If a difference is observed after comparing 1 to 4 cycles (reference cycles) of the previous waveform and the current waveform, a trigger is activated. Therefore, if an abnormal waveform such as surge is contained in the 1 to 4 cycles of the previous waveform, a trigger is activated on the normal waveform. In such case, the trigger point may appear as though it is delayed by several cycles as shown in the figure below. This phenomenon is unavoidable due to the principles of the wave window trigger.

Trigger appears as though it is delayed by 1 cycle.

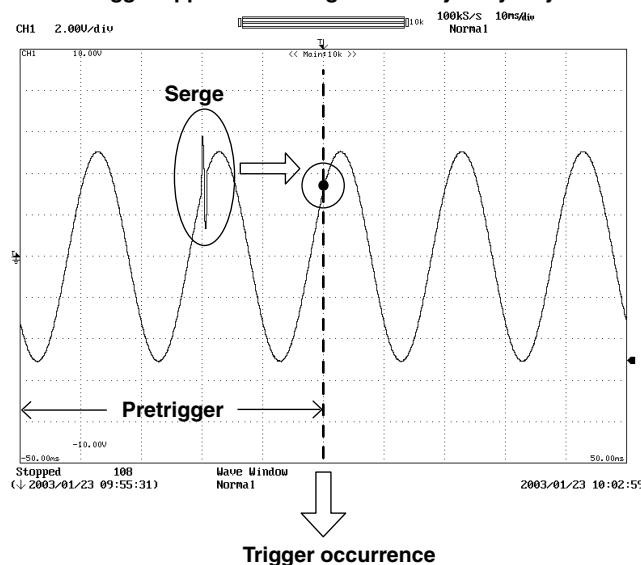

The time difference from the abnormal waveform to the trigger point varies depending on the reference cycle as follows. When the frequency of the trigger is low, the time difference from the abnormal waveform to the trigger point is 0 cycles in most cases.

Reference Cycle	Time Difference
1 cycle	0 or 1 cycle
2 cycles	0, 1 or 2 cycles
4 cycles	0, 1, 2, 3, or 4 cycles

When using the wave window trigger, it is recommended that a pretrigger equal to the reference cycle be specified. This allows abnormal waveforms to be observed even when the above phenomenon occurs.

### Selecting the Trigger Condition

ON: Use the channel as a target channel for the wave window trigger.

OFF: Do not use the channel as a target channel for the wave window trigger.

- **Cycle Frequency**

Set the frequency of the measured power supply in the range of 40 to 1000 Hz. The resolution is 0.1 Hz. The default value is 50 Hz.

If the actually frequency is within  $\pm 10\%$  of the specified value, it is automatically tracked.

- **Reference Cycle**

Select how many waveforms before the current waveform are used to create the realtime template (wave window).

1 (1 waveform), 2 (2 waveforms), or 4 (4 waveforms)

The waveforms of the specified number of reference cycles are used to create the realtime template.

- **Sync. Ch, Level, and Hys**

Select the channel used to detect the waveform determination start point of the wave window trigger. Select the synchronization channel from Auto or CH1 to CH16.

If a setting other than Auto was selected, set the level and hysteresis of the synchronization channel.

If set to Auto, the synchronization channel is automatically set using the following conditions.

Target channel: Channel with the smallest channel number among the target channels of the wave window trigger.

Level:  $1/2$  the peak-to-peak value over 0.5 s after starting the waveform acquisition.

Hysteresis: Same as the hysteresis of an edge trigger (see section 6.5)

If a setting other than Auto was selected, set the level and hysteresis of the synchronization channel.

- **Setting the Level**

The selectable range of the level is the same as that of the simple trigger.

- **Setting the Hysteresis**

Sets a width to the trigger level so that triggers are not activated by small changes in the trigger signal. Select the trigger hysteresis from  $\overline{\wedge}$ ,  $\overline{\neq}$ , and  $\overline{\nabla}$ .

For details, see "Setting the Trigger Hysteresis" in section 6.5.

## 6.17 Setting the Wave Window Trigger (ENHANCED)

---

### Window Width

The realtime template is created by applying a tolerance width (window width) to the averaged waveform. The selectable range of the window width varies depending on the observed item as follows.

When observing voltage:  $(V/div) \times 1/100$  to  $(V/div) \times 10$

When observing strain:  $1 \mu\text{STR}$  to  $(\text{measurement range}) \times 2$

Or,  $0.0005 \text{ mV/V}$  to  $(\text{measurement range}) \times 2$

When measuring acceleration:  $0.01 \text{ Unit}$  to  $(\text{Unit/div}) \times 10$

(The resolution is the same as the resolution of the trigger level. See section 6.5.)

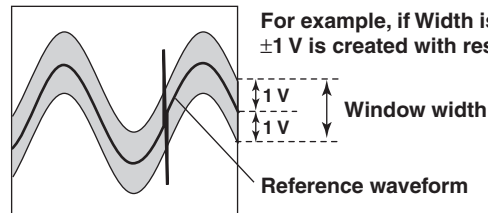

### Hold Off

For details, see section 6.4, "Setting the Hold Off Time."

### Note

If a trigger waveform such as a surge is input immediately before the completion of the pre-trigger, the trigger point may be delayed by up to 4 cycles.

---

## 6.18 Setting the Action-on-Trigger

<For a description of this function, refer to page 2-29.>

### Procedure

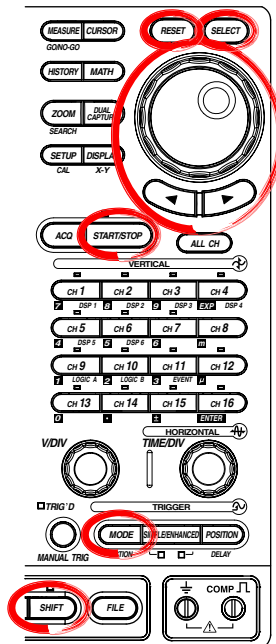

1. Press **SHIFT+MODE**. The ACTION menu appears.

### Setting the Action

2. Press the **Mode** soft key. The Mode select menu appears.
3. Press the soft key corresponding to the desired mode: OFF, On Trigger, or On Stop.
4. Press the **Action** soft key. The Action setup menu appears.
5. Use the **jog shuttle** and **SELECT** to select action to be enabled. (You can select multiple actions.)
6. If you selected Save to File in step 3, use the **jog shuttle** and **SELECT** to set the file save format to Binary, ASCII, or Float. If you selected Send Mail, use the **jog shuttle** and **SELECT** to set Mail Count.

### Setting the Number of Actions

7. Press the **Sequence** soft key to select Single or Continuous.
8. Press the **ACQ Count** soft key.
9. Turn the **jog shuttle** to set the number of actions. Pressing **RESET** resets the count Infinite.

### Setting the Execution Mode of the Action-on-Trigger/Action-on-Stop at Power ON

10. Press **MISC**.
11. Press the **Next 1/2** soft key.
12. Press the **Others** soft key.
13. Press the **Action Mode(Power ON)** soft key to select ON or OFF.

### Executing the Action-on-Trigger/Action-on-Stop

14. Press **START/STOP** to start the waveform acquisition and execution the action-on-trigger. While action-on-trigger or action-on-stop is in execution, is displayed at the upper left corner of the screen.

In addition, if the following action is specified, the following icon is displayed in the upper left corner of the screen while the action is being executed.

Image/Save to File: Save destination medium ( FD, Zip disk, PC card, SCSI device, internal HD, network drive, or USB storage device.)

Send Mail:

### Aborting the Action-on-Trigger/Action-on-Stop

15. Press **START/STOP** to stop the waveform acquisition and abort the action-on-trigger or action on stop.

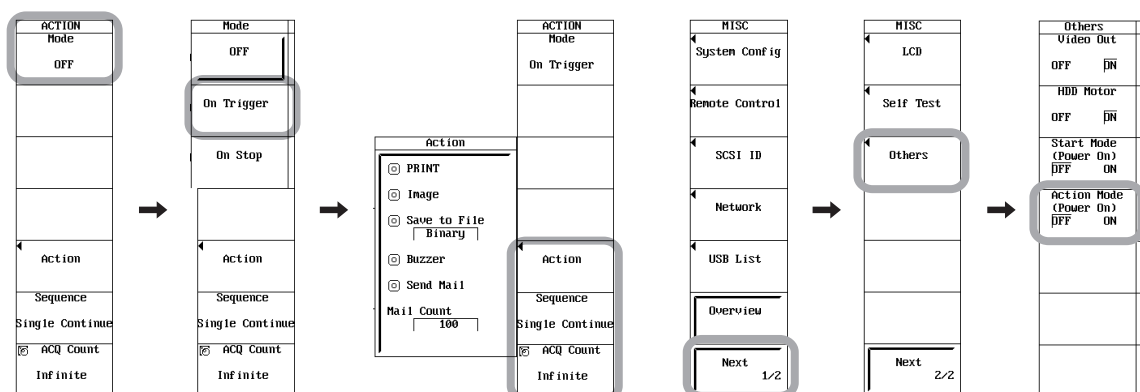

### Explanation

#### Setting the Mode

- **On Trigger (Action-on-Trigger)**  
A specified action is executed each time a trigger is activated. When action-on-trigger is enabled, the trigger mode is set to Single.
- **On Stop (Action-on-Stop)**  
The specified record length of data is acquired when measurement is started, and the waveform is displayed. Then, the specified action is executed. When action-on-stop is enabled, the trigger mode is set to Log.

#### Setting the Action

The following five types of actions are available.

- **Print the Screen Image Data: PRINT**  
Prints the screen image data on the printer (Printer (built-in printer), USB (USB printer), or Net Print (network printer)) specified by Print to in the PRINT menu.
- **Save the Screen Image Data: Image**  
Saves the screen image data to the destination (FD, Zip disk, PC card, internal HD (optional), SCSI device, or USB storage device) specified in the IMAGE SAVE menu.
- **Save the Waveform Data: Save to File**  
Saves the waveform data in binary, ASCII, or floating format to the destination (FD, Zip disk, PC card, internal HD (optional), SCSI device, or USB storage device) specified in the FILE menu. The save format is synchronized to data type (see section 13.7) on the FILE menu.
- **Buzzer**  
Sounds a buzzer.
- **Send Mail**  
Sends an e-mail message to a specified address (when Ethernet interface option is installed). Set the number of e-mail transmission in the range of 1 to 1000.  
For the procedure in setting the address, see section 16.5, "Sending Periodic Mail or Action Mail."

#### Note

---

If action-on—trigger is used, the data is acquired in Single mode regardless of the trigger mode setting, and the specified action is carried out.

---

#### Setting the Number of Actions

##### Sequence

Single: Performs the action once.

Continue: Performs the action the number of times specified by ACQ Count.

##### ACQ Count

2 to 65536: Repeats the action the specified number of counts.

Infinite: Repeats the action until waveform acquisition is stopped.

#### Save to File/Hard Copy/Image Operation

Operates according to the settings in the FILE, PRINT, or Image Save menu.

#### File Name When Action Is Set to Save to File or Image

If the Auto Naming of the File menu or the Image Save menu is OFF, numbers are automatically assigned to the file names. Otherwise, the file is saved using the specified method.

For details, see section 13.11, "Saving the Screen Image Data" or section 13.7, "Saving/ Loading Waveform Data."



**Send Mail Operation**

Sends e-mail messages to the address specified using Network > Mail Setup > Mail Address in the MISC menu.

**Note**

- If action-on-trigger is started, the data is acquired in single mode trigger regardless of the trigger mode setting, and the specified action is carried out.
- If action-on-stop is started, the data is acquired in Log mode regardless of the trigger mode setting, and the specified action is carried out. The specified action is also carried out when the measurement is stopped in the middle of the measurement.

**Setting the Execution Mode of the Action-on Trigger/Action-on Stop at Power ON**

You can select whether to enable the action-on-trigger or action-on-stop mode at power ON. For example, turn this ON if you wish to continue the action-on-trigger or action-on-stop operation after a power failure.

ON: At power ON, the action-on-trigger/action-on-stop is set to the mode that was used when the power was turned OFF.

OFF: Action Mode is turned OFF at power ON.

The initial setting is OFF.

**Notes When Using the Action-on-Trigger/Action-on-Stop**

- Action-on-trigger and action-on-stop cannot be used if the acquisition mode is Average.
- You cannot change the settings while the action-on-trigger or action-on-stop is in progress.
- The action-on-trigger or action-on-stop operation may slow down if there is access from the network while the following action is in progress.  
Printing/saving of the screen image data or saving of the waveform data
- Action-on-triggers other than mail transmission are not available when the Dual Capture function is ON. Also, none of the action-on-triggers are available if the firmware is of a version earlier than 4.01.
- You cannot use action-on-trigger or action-on-stop when the realtime recording to the internal hard disk is ON.

**Notes When Action Is Set to Save to File or Image Save**

- Do not specify the root directory of the medium as the save destination directory. (Only up to 512 files can be saved to the root directory of a medium that has been formatted using the DL750/DL750P.)
- The maximum number of files that can be created in a single directory is 5000. Do not place files in the save destination folder before starting the action-on-trigger or action-on-stop operation.
- If you select Save to File and Image Save simultaneously, separate the folders specified by the FILE menu and the IMAGE SAVE menu.
- If you selected Numbering for the file name assignment method (Auto Naming) in the FILE menu and the IMAGE SAVE menu, the creation of files takes an extended period when the number of saved files becomes large. When creating more than 2000 files, select Date for Auto Naming.
- When 5000 files are saved, the action-on-trigger or action-on-stop operation ends.

## 6.19 Setting Manual Triggers

<For a description of this function, refer to page 2-30.>

### Procedure

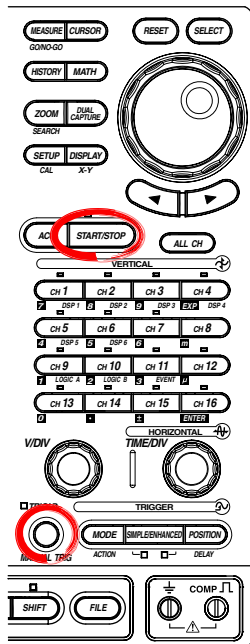

1. Press **START/STOP** to start the waveform acquisition.
2. Press **MANUAL TRIG** to manually activate the trigger.

### Explanation

You can manually activate a trigger by pressing the MANUAL TRIG key on the front panel.

# 7.1 Starting/Stopping Waveform Acquisition

## Procedure

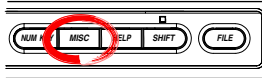
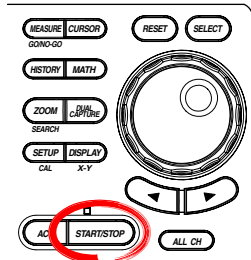

### Setting the Waveform Acquisition Mode at Power ON

1. Press **MISC**.
2. Press the **Next 1/2** soft key
3. Press the **Others** soft key.
4. Press the **Start Mode(Power On)** soft key to select ON or OFF.

### START/STOP Key Response Time Setting

5. Press the **START/STOP Response Time** soft key, then select Quick or >1sec.

### Starting/Stopping Waveform Acquisition

6. Press **START/STOP**. Waveform acquisition is started/stopped. Waveform acquisition is in progress when the indicator above and to the right of the key is illuminated.

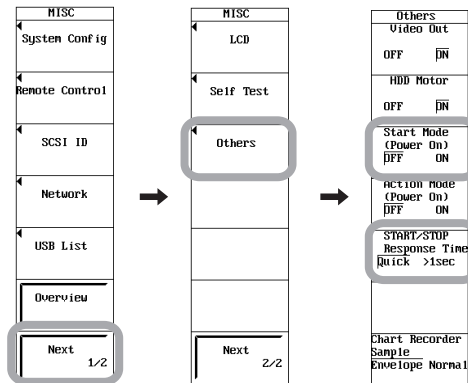

## Explanation

### Waveform Acquisition and Indicator Display

- If the indicator above START/STOP is illuminated, the waveform acquisition is in progress. "Running" is displayed at the lower left corner of the screen.
- If the indicator above START/STOP is not illuminated, the waveform acquisition is stopped. "Stopped" is displayed at the lower left corner of the screen.

### Operation When the Acquisition Mode Is Set to Averaging Mode

- Averaging is stopped when waveform acquisition is stopped.
- Averaging starts again when waveform acquisition is restarted.

### START/STOP Operation during Accumulation

Accumulation is suspended when acquisition is stopped. It is resumed when acquisition is restarted.

## 7.1 Starting/Stopping Waveform Acquisition

---

### **Conditions When Waveform Acquisition Cannot Be Started or Stopped**

- Remote mode using the communication interface
- When printing or during auto setup

### **Setting the Waveform Acquisition Mode at Power ON**

You can select whether to start waveform acquisition at power on. For example, select ON if you wish to start waveform acquisition when power supply recovers after a power failure. The initial setting is OFF.

ON: Starts waveform acquisition at power on.

OFF: Does not start waveform acquisition at power on.

### **START/STOP Key Response Time Setting**

You can enter a setting to specify whether the instrument responds immediately when the START/STOP key is pressed, or whether the instrument only responds if the key is pressed for one second or longer.

Quick: Immediate response

>1sec: Responds when the key is pressed for one second or longer

### **Note**

---

- If you start waveform acquisition after changing the waveform acquisition conditions indicated below, the data that had been stored in the acquisition memory up to that point is cleared.
    - Setup conditions on the ACQ menu
    - Setup conditions of the module
      - Input coupling of the 701265 (TEMP/HPV) (when a change is made between TC and some other setting) and the thermocouple type setting (when measuring temperature)
      - Input coupling of the 701275 (ACCL/VOLT) (when a change is made between ACCL and some other setting) and the sensitivity setting (when measuring acceleration)
      - FV setting of the 701280 (FREQ) and offset setting
    - Trigger setup conditions
    - Setup conditions of the DUAL CAPTURE menu
    - T/div
  - A snapshot function that keeps the current displayed waveform on the screen is also available. You can update the display without stopping the waveform acquisition (see the next section).
  - For a description of the behavior when the Start Mode (Power On) is ON or OFF, see appendix 9.
  - When waveforms are being acquired using roll mode display (see page 2-4), voice memo can be recorded. For details, see section 7.9, "Using the Voice Memo Function."
-

## 7.2 Setting the Record Length

<For a description of this function, refer to page 2-31.>

### Procedure

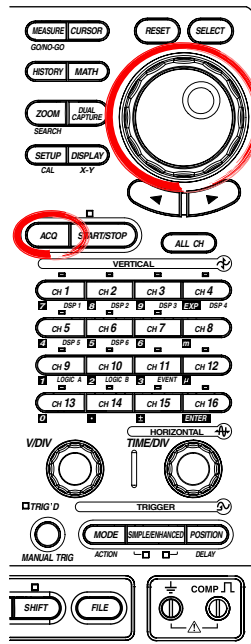

1. Press **ACQ**.
2. Press the **Record Length** soft key.
3. Turn the **jog shuttle** to set the record length.

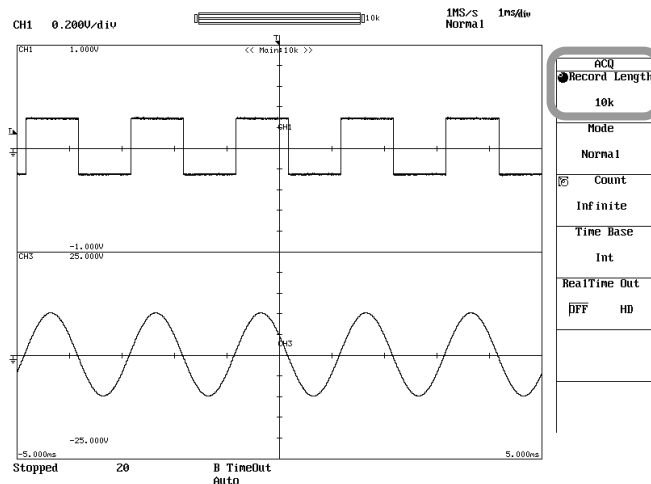

### Explanation

The record length sets the amount of data to be written into the acquisition memory. The selectable maximum record length varies depending on the model.

- **2.5 MW/CH Model (Standard)**  
1 kW, 2.5 kW, 5 kW, 10 kW, 25 kW, 50 kW, 100 kW, 250 kW, 500 kW, 1 MW, 2.5 MW, 5 MW, 10 MW, 25 MW, and 50 MW
- **10 MW/CH Model (/M1 Option)**  
1 kW, 2.5 kW, 5 kW, 10 kW, 25 kW, 50 kW, 100 kW, 250 kW, 500 kW, 1 MW, 2.5 MW, 5 MW, 10 MW, 25 MW, 50 MW, 100 MW, and 250 MW
- **25 MW/CH Model (/M2 Option)**  
1 kW, 2.5 kW, 5 kW, 10 kW, 25 kW, 50 kW, 100 kW, 250 kW, 500 kW, 1 MW, 2.5 MW, 5 MW, 10 MW, 25 MW, 50 MW, 100 MW, 250 MW, and 500 MW
- **50 MW/CH Model (/M3 Option)**  
1 kW, 2.5 kW, 5 kW, 10 kW, 25 kW, 50 kW, 100 kW, 250 kW, 500 kW, 1 MW, 2.5 MW, 5 MW, 10 MW, 25 MW, 50 MW, 100 MW, 250 MW, 500 MW, and 1 GW

### **Notes When Setting the Record Length**

- Increasing the record length automatically limits the number of channels that can be used. The display of the channels which can no longer be used because the record length is increased can not be turned ON/OFF. The number of channels that can be used is displayed on the soft key menu of Record Length of the ACQ menu (right of the record length display).
- The maximum record length when acquisition mode is average is 1 MW on the standard model, 2.5 MW on the M1 option model, 5 MW on the M2 option model, and 10 MW on the M3 option model. (For details, see appendix 1.)
- The maximum record length when using the dual capture function is 5 MW on the standard model, 10 MW on the M1 option model, 50 MW on the M2 option model, and 100 MW on the M3 option model. (For details, see appendix 1.)
- The maximum record length when performing realtime recording is 1 GW (1 CH).
- When the trigger mode is Auto, Auto Level, Normal, or Single (N) and the display is not in roll mode, you cannot select a record length that is greater than or equal to 2.5 MW on the standard model, 10 MW on the M1 option model, 25 MW on the M2 option model, and 50 MW on the M3 option model.

## 7.3 Setting the Acquisition Mode

<For a description of this function, refer to page 2-31.>

### Procedure

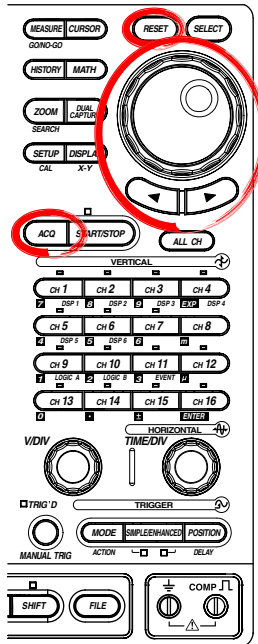

### Setting the Action Mode

1. Press **ACQ**.
2. Press the **Mode** soft key. The mode selection menu appears.
3. Press the soft key corresponding to the desired mode from Normal, Envelope, Average, and Box Average.  
You may not be able to select some modes depending on the trigger mode setting.

### Setting the Acquisition Count

4. Press the **Count** soft key.  
You cannot set the acquisition count when the trigger mode is Single, Single (N), or Log.
5. Turn the **jog shuttle** to set the acquisition count.  
Pressing **RESET** resets the count to Infinite.  
If the acquisition mode is Average and you set Count to Infinite, proceed to step 6.

### Setting the Attenuation

(When the Acquisition Mode Is Average and Count Is Infinite)

6. Press the **Weight** soft key.
7. Turn the **jog shuttle** to set the attenuation.

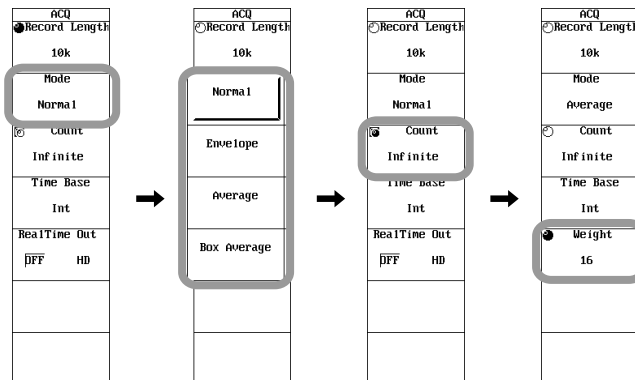

**Explanation**

**Selecting the Acquisition Mode**

You can select any of the acquisition modes below. The default setting is Normal.

- **Normal Mode**  
Sampled data are stored in the acquisition memory without special processing.
- **Envelope Mode**  
The maximum and minimum values are determined every acquisition interval from the data sampled at 10 MS/s. The maximum and minimum values are stored to the acquisition memory and an envelope waveform is displayed.
- **Average Mode**  
Sampled data is averaged and stored to the acquisition memory. The averaging method varies depending on the acquisition count setting.  
If the acquisition count is set to Infinite, exponential averaging is performed. You are required to set the attenuation (Weight).  
If the acquisition count is set to a value in the range of 2 to 65536, simple averaging is performed. The specified value is the average count.

- **Exponential average (when set to Infinite)**
- **Simple average (when set to 1 to 65536)**

$$A_n = \frac{1}{N} \{(N-1)A_{n-1} + X_n\}$$

**A<sub>n</sub>**: nth averaged value  
**X<sub>n</sub>**: nth measured value  
**N**: Attenuation (2 to 256, 2<sup>n</sup> steps)

$$A_N = \frac{\sum_{n=1}^N X_n}{N}$$

**X<sub>n</sub>**: nth measured value  
**N**: Average count (acquisition count, 2<sup>n</sup> steps)

You cannot use averaging mode when the trigger mode is Single, Single (N), or Log. In addition, you cannot use averaging mode when the dual capture function is used or when realtime recording is in progress.

For details on the roll mode, see appendix 1, "Relationship between the Time Axis Setting, Sample Rate and Record Length."

- **Box Average Mode**  
For details, see section 7.4, "Acquiring Data Using Box Average."

**Note**

---

For the procedure of switching the acquisition mode in Chart Recorder mode on the DL750P, see section 9.3.

---

**Acquisition Count**

Set the acquisition count in the following range. If you set the value to Infinite, acquisition will continue until you press the START/STOP key. The default setting is Infinite. You cannot change the acquisition count during measurement. The new value is activated when the measurement is stopped.

Normal, Envelope, and Box Average: 2 to 65536 (in 1 step) and Infinite  
 Average: 2 to 65536 (in 2<sup>n</sup> steps) and Infinite



#### **Notes on Averaging**

- Averaging is effective only against repetitive waveforms.
- Correct averaging is not possible if the waveform has imperfect triggering (incomplete synchronization), and the displayed waveform will be distorted. When working with this type of signal, set the trigger mode to Normal, so that the waveform display is updated only when the trigger is activated (see section 6.1).
- Roll mode display is disabled during averaging.
- Averaging is not possible when the trigger mode is Single, Single (N), or Log.
- If you stop waveform acquisition by pressing the START/STOP key, the averaging process also stops. Averaging restarts from the beginning when acquisition resumes.
- If you are using simple averaging, the DL750/DL750P terminates acquisition automatically when it completes the specified number of acquisitions (acquisition count).
- Averaging is not possible when the dual capture function is used or when realtime recording is in progress.
- When acquiring waveforms in averaging mode, the data that is retained in the history memory is 1 record.

# 7.4 Acquiring Data Using Box Average

<For a description of this function, refer to page 2-32.>

## Procedure

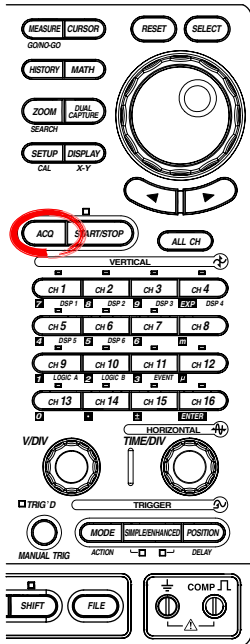

1. Press **ACQ**.
2. Press the **Mode** soft key. The mode selection menu appears.
3. Press the **Box Average** soft key.

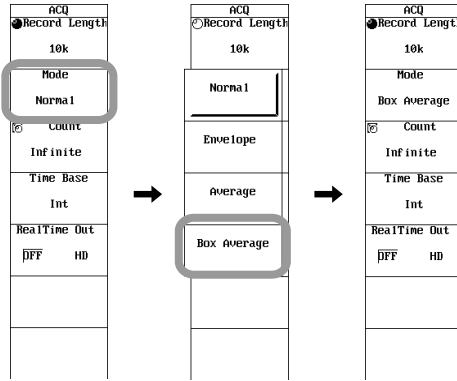

## Explanation

This function is valid only on the 701250 (HS10M12) and the 701255 (NONISO\_10M12). At sample rates that allow box averaging, data is normally sampled at 10 MS/s and the sampled data is decimated according to the T/div setting and stored to the acquisition memory. The internal sample rate is the same as the envelope mode. For details, see appendix 1, "Relationship between the Time Axis Setting, Sample Rate and Record Length."

When you use the box averaging function, the operation is different. Moving average is computed on a given number of data points and the result is sampled and stored to the acquisition memory.

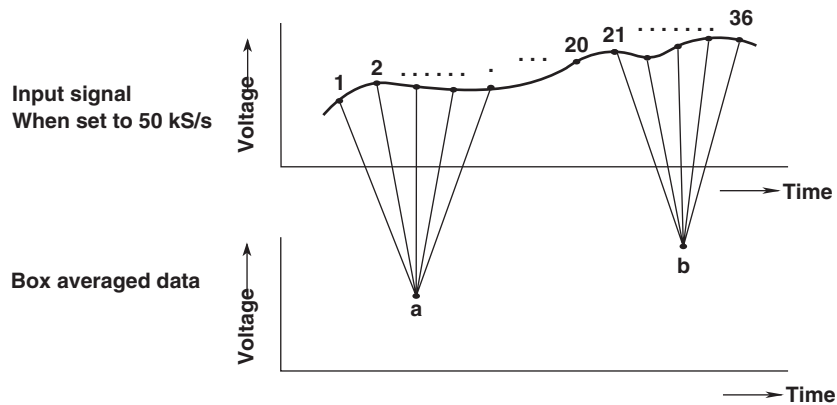

**Number of Data Points on Which Moving Average Is Computed**

<b>Sample Rate (S/s)</b>	<b>Number of Data Points</b>
10 M <sup>1</sup>	1 point
5 M	2 points
2 M	4 points out of 5 points
1 M	8 points out of 10 points
500 k	16 points out of 20 points
200 k	32 points out of 50 points
100 k	64 points out of 100 points
50 k	128 points out of 200 points
20 k	256 points out of 500 points
10 k or less	256 points out of (10 M ÷ sample rate)

1. Same operation as the normal mode.

## 7.5 Acquiring Data Using the Sequential Store Function (Single (N) Mode)

<For a description of this function, refer to page 2-33.>

### Procedure

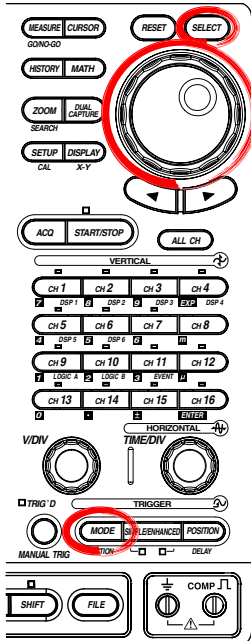

1. Press **MODE**.
2. Press the **Single(N)** soft key.
3. Use the **jog shuttle** and **SELECT** to set Single(N) Count.

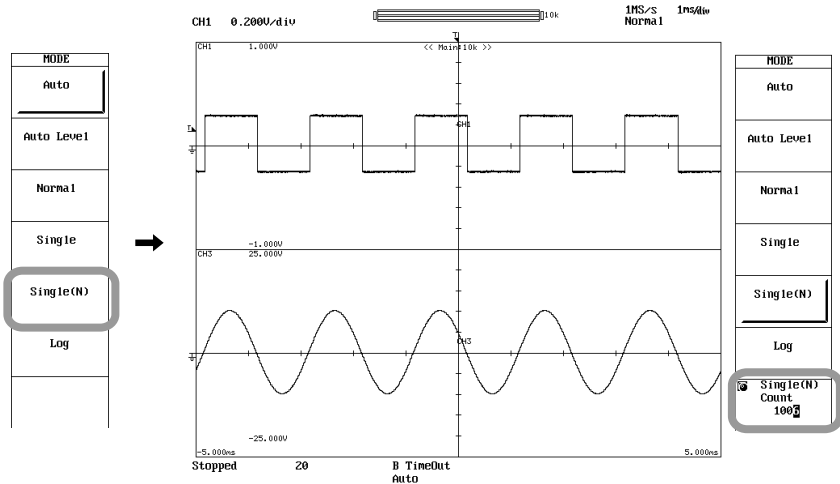

### Explanation

By setting the trigger mode to Single(N), the sequential store function can be used.

#### Acquisition Count

Set the acquisition count in the range from 1 to 2000.

However, the selectable acquisition count varies depending on the selected record length and acquisition mode.

For details, see appendix 1, "Relationship between the Time Axis Setting, Sample Rate and Record Length."

#### Displaying Waveforms

You can recall waveforms from memory in the same fashion as for the history memory function.

For details, see section 11.1, "Displaying History Waveforms."

#### Notes When Using Sequential Store

- If you stop waveform acquisition by pressing the START/STOP key, the sequential store operation also stops. Sequential store restarts from the beginning when acquisition resumes.

# 7.6 Using the Dual Capture Function

<For a description of this function, refer to page 2-34.>

## Procedure

### DL750

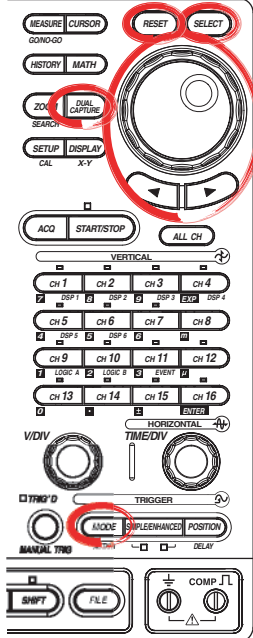

### DL750P

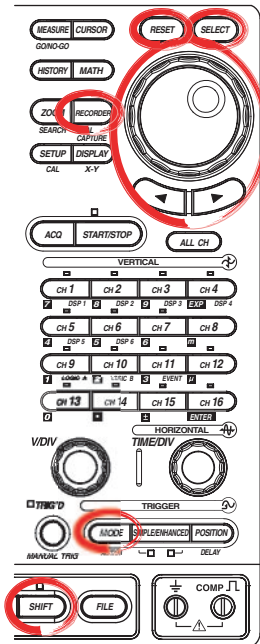

### Setting the Main Waveform (Low-Speed)

- **Set the Trigger Mode**
  1. Press the **MODE** soft key.
  2. Press the soft key corresponding to **Auto** or **Log**.
- **Setting the Roll Mode Display**
  3. Turn TIME/DIV to set T/div to 100 ms/div to 3 day/div.

### Setting the Sub Waveform (High-Speed)

4. Press **DUAL CAPTURE**. (On the DL750P, press **SHIFT+RECORDER (DUAL CAPTURE)**.)
5. Press the **Mode** soft key to select ON.

### Setting the Time Axis

6. Press the **Time/Div** soft key.
7. Turn the **jog shuttle** to set the time axis of the sub waveform. The top row displays Time/Div; the bottom row displays the sample rate.

### Setting the Sub Waveform Window

8. Press the **Window** soft key.
9. Press any of the soft keys from **OFF**, **Right**, **Left**, or **Full**.

### Setting the Zoom Ratio/Display Position

10. Press the **Window Mag/Window Pos** soft key to set the jog shuttle control to Window Mag.
11. Turn the **jog shuttle** to set the zoom ratio of the sub waveform. Pressing **RESET** resets the value to default.
12. Press the **Window Mag/Window Pos** soft key to set the jog shuttle control to Window Pos.
13. Turn the **jog shuttle** to set the display position of the sub waveform. Pressing **RESET** resets the value to default.

### Turning ON/OFF the Event Waveform Display

14. Press the **Event Display** soft key to select OFF or ON. For a description of event waveforms, see section 5.21.

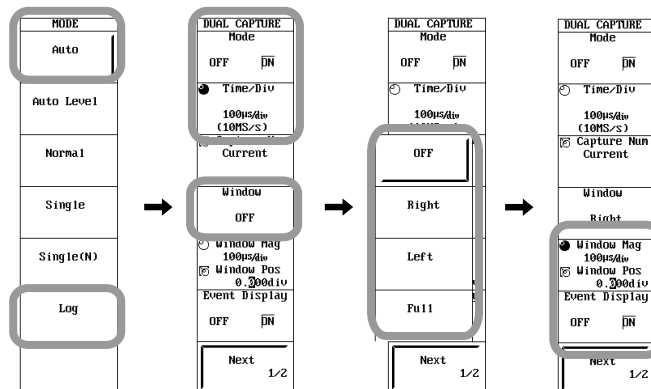

**Selecting the Display Format of Sub Waveforms**

15. Press the **Next 1/2** soft key.
16. Press the **Format** soft key. The display format selection menu appears.
17. Use the **job shuttle** and **SELECT** to select the display format of the sub waveforms.

**Selecting the Channels to Be Displayed in the Sub Waveform Window**

18. Press the **Allocation** soft key. A menu used to select the channels to be displayed appears.
19. Use the **job shuttle** and **SELECT** to select the channels whose waveforms are to be displayed.

**Turning ON/OFF Mail Transmission**

20. Press the **Send Mail** soft key. The mail transmission setup menu appears.
21. Press the ON or OFF soft key.
22. Use the **job shuttle** to set the number of times to send the mail.

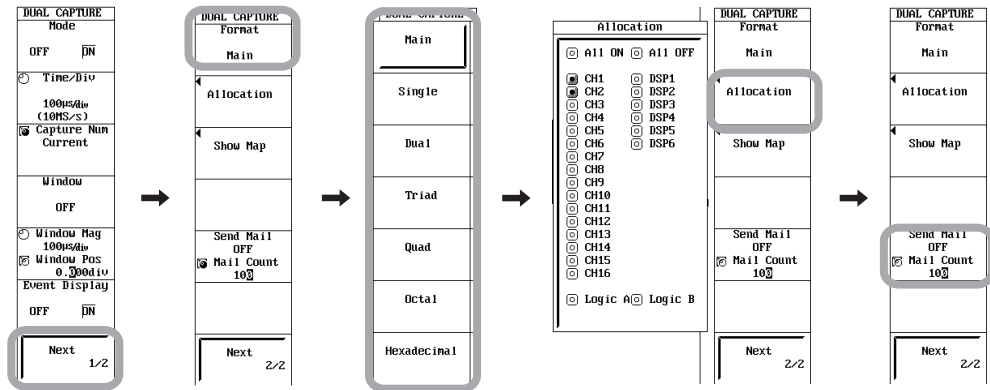

**Executing the Waveform Acquisition**

23. Press **START/STOP** to start the waveform acquisition. When a trigger is activated on the specified trigger conditions, the waveform is displayed in the sub waveform window.

**Specifying and Displaying the Captured Waveform**

24. Press the **Capture Num** soft key.
25. Turn the **job shuttle** to specify the number of the waveform you wish to display.

**Displaying a Waveform from the List of Captured Waveforms**

26. In the 2/2 menu, press the Show Map soft key. A list of acquired waveforms is displayed.
27. Turn the **job shuttle** to select the waveform to be displayed and press **SELECT**.

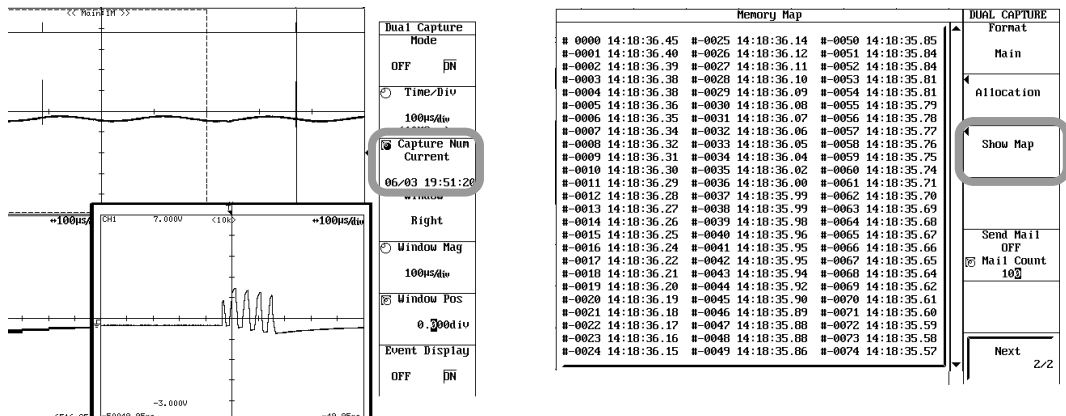

## Explanation

This function enables waveform acquisition in low-speed roll mode (main waveform) along with high-speed waveforms (sub waveform) at a different sampling interval. It is useful when capturing at high speeds abnormal phenomenon that occurs suddenly during long-term observation (low-speed sampling). The sub waveform is saved simultaneously when the main waveform is saved. Likewise, when the main waveform is loaded, the sub waveform is also loaded. This function is valid when the acquisition mode is set to normal, envelope, or box average.

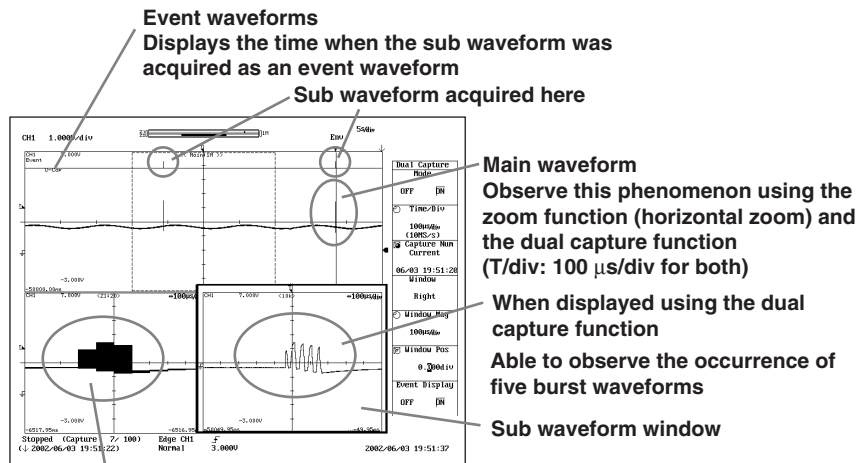

When displayed using the zoom function  
Cannot tell how many burst waveforms occurred

The dual capture function has the following two trigger modes.

- **Auto Mode**

For the main waveform, measurement is performed from the time sampling is started until there is a request to end the sampling. The number of sub waveforms that can be saved varies between the standard model and memory expansion models (/M1, /M2, and /M3).

Standard model: Up to 100

/M1 model: Up to 250

/M2 and /M3 models: Up to 500

If the maximum number of sub waveforms is exceeded, the oldest sub waveform is deleted, and the newest waveforms are saved.

- **Log Mode**

For the main waveform, the waveform is acquired from the time sampling is started up to the specified record length. For the sub waveform, up to 100 sets can be stored. When this number is reached, the acquisition of sub waveforms stops.

### Waveform Acquisition Condition of the Dual Capture Function

Waveforms can be acquired when all of the following conditions are met.

- When the T/div setting of the main waveform is from 100 ms/div to 3 days/div
- When the sample rate of the main waveform is less than or equal to 100 kS/s
- When the sample rate of the main waveform is less than the sample rate of the sub waveform

### Applicable Channels

The applicable channels are all channels that are identified for both main waveform and sub waveform (However, when the record length is greater than or equal to 2.5 MW on the standard model, 10 MW on the M1 option model, 25 MW on the M2 option model, and 50 MW on the M3 option model, the applicable channels are those that are turned ON). DSP channels are also applicable.

### Setting the Sub Waveform

- **Record Length of the Sub Waveform**  
Fixed to 10 kW.
- **Time/div Setting of the Sub Waveform**  
The maximum sample rate is 10 MS/s.
- **Acquisition Mode of the Sub Waveform**  
Fixed to Normal.
- **Trigger Setting of the Sub Waveform**  
When the dual capture mode is turned ON, the trigger setting is no longer applied to the main waveform, but applied to the sub waveform.  
In addition, the trigger output during acquisition in dual capture mode becomes the trigger output of the sub waveform.
- **Sub Waveform Display: Window**  
Select the from the following four types.  
OFF: Does not display the sub waveform.  
Right : Displays the sub waveform at the lower right section of the screen at 1/4 size.  
Left: Displays the sub waveform at the lower left section of the screen at 1/4 size.  
Full: Displays the sub waveform on a full screen.
- **Waveform Display Position: Window Pos**  
Set the display position of the sub waveform.
- **Sub Waveform Zoom Ratio: Window Mag**  
The sub waveform is displayed at the zoom rate specified by Window Mag around the waveform display position specified by Window Pos.
- **Display Format of Sub Waveforms**  
Set the display format of sub waveforms.

Main:	Same format as the main window	Single:	1 window
Dual:	2 windows	Triad:	3 windows
Quad:	4 window	Octal:	8 windows
Hexadecimal:	16 windows		

### **Selecting the Displayed Trace: Allocation**

The traces that are turned ON under Allocation are displayed.

- **Displaying the Acquired Waveform: Capture Num**  
You can specify the number of the acquired waveform to be displayed in the sub waveform window.

The time that is shown below the number is the trigger time of the waveform.

#### **When in Auto Mode**

Current, -1, -2, ....

where current is the newest waveform, -1 is the waveform previous to the newest waveform, and -2 is the waveform that is 2 triggers before the newest waveform.

The acquired waveform can be displayed only when the waveform acquisition is stopped.

#### **When in Log Mode**

Current, 1, 2, ....

where current is the newest waveform, 1 is the oldest waveform, and 2 is the second oldest waveform.

The acquired waveform can be displayed even when the waveform acquisition is in progress.



- **Displaying the List of Captured Waveforms: Show Map**

The number of the acquired waveform and the trigger time are listed. You can also select the desired waveform number to display the list.

- **Send Mail**

When turned ON, a mail is sent to the mail address specified in NetWork settings each time a waveform is acquired. For details, see section 16.5, "Sending Periodic Mail or Action Mail."

### ▼ Mark

The ▼ mark indicates the position of the sub waveform specified by Capture Num at the top section of on the main waveform window. However, when waveforms are being acquired in the Auto mode, the ▼ mark is not displayed for sub waveform positions that exceed the end of the main waveform.

### Note

Key response is slowed down when waveform acquisition is in progress using the dual capture function.

### Notes When Using the Dual Capture Function

- The dual capture function can be used only when the trigger mode is set to Auto or Log.
- The maximum record length of the main waveform varies depending on the model as follows: The dual capture function cannot be used at record lengths that exceed the maximum record length.
 

Standard model: 5 M	/M1 model: 10 M
/M2 model: 50 M	/M3 model: 100 M
- The dual capture function cannot be used if the acquisition mode of the main waveform is Average.
- The dual capture function and the realtime recording function cannot be used simultaneously.
- The dual capture mode cannot be changed while waveform acquisition is in progress.
- If you restart measurements after acquiring waveforms, all the waveforms that were acquired before changing the mode are cleared.
- The dual capture function cannot be applied to X-Y waveforms.
- Saving/loading of the waveforms acquired using the dual capture function is performed simultaneously for the main waveform and the sub waveform. For details on the saving/loading of the waveform, see section 13.7, "Saving/Loading Waveform Data."
- The dual capture function cannot be used if the time base is set to external clock.
- Accumulate function cannot be used.
- Cursor measurements and automated measurement of waveform parameters are suspended while waveforms are acquired using the dual capture function.
- Automated measurement of waveform parameters and computations cannot be performed on the sub waveform.
- When the sub waveform is displayed, cursor measurements are made on the sub waveform.

# 7.7 Realtime Recording to the Internal Hard Disk (Optional)

<For a description of this function, refer to page 2-35.>

## Procedure

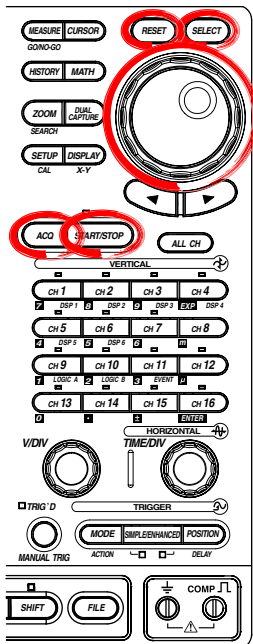

1. Press **ACQ**.
2. Press the **RealTime Out** soft key to select HD.

### Note

The RealTime Out menu does not appear if Time Base is set to Ext.

### Setting the Realtime Recording

3. Press the **RealTime Out Setup** soft key. A setup dialog box opens.
4. Use the **jog shuttle** and **SELECT** to set Sequence to Single or Continue.
5. If you selected Continue in step 4, use the **jog shuttle** and **SELECT** to set Count to a value in the range of 2 to 128.
6. Use the **jog shuttle** and **SELECT** to select the Auto Naming method from OFF, Numbering, and Date.
7. As necessary, enter the File Name and Comment according to the procedures given in section 4.2.

### Executing the Realtime Recording

8. Press the **START/STOP** key to start the waveform acquisition. Realtime recording is executed. While realtime recording is executing,  is displayed at the upper left corner of the screen.

### Aborting the Realtime Recording

9. Press the **START/STOP** key to stop the waveform acquisition. Realtime recording is aborted.

### Note

If you stop the waveform acquisition by pressing the START/STOP key, realtime recording is aborted even if it is within the specified recording time.

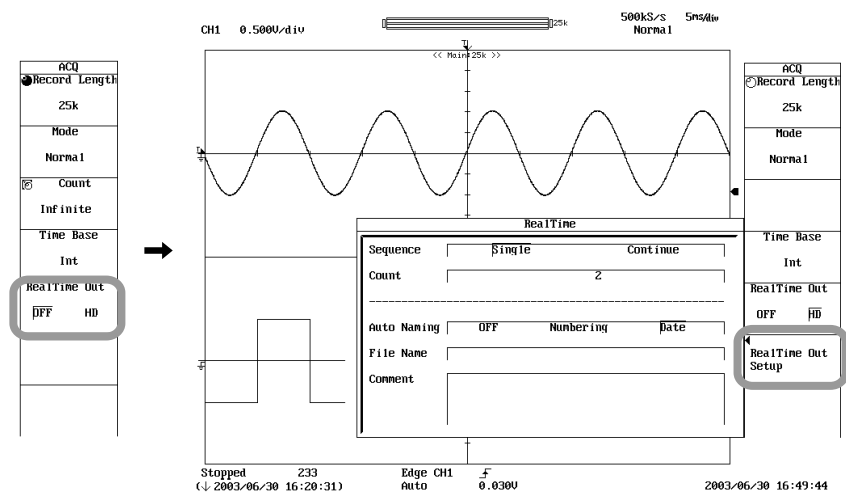

**Explanation**

The data can be recorded in realtime to the internal hard disk (optional).

The internal hard disk consists of the following drives.

**Realtime:** For realtime recording. You can set the realtime recording area in the range of 30% to 70% of the entire capacity of the internal hard disk when you format the internal hard disk (see section 13.5).

**HD-0, HD-1\*:** For saving various data.

\* HD-0 only if the internal hard disk is partitioned to 2; HD-0 and HD-1 if the internal hard disk is partitioned to 3.

**Waveforms That Are Realtime Recorded**

All normal waveforms displayed on the screen are realtime recorded.

**Possible Time Axis Range, Maximum Record Length, and Maximum Sample Rate for Realtime Recording**

Varies depending on the number of channels that are to be realtime recorded as follows:

Number or Channels	Time Axis Range	Maximum Record Length	Maximum Sample Rate
18 channels or more	20 s/div to 3 day/div	25 MW	5 kS/s
12 to 17 channels	20 s/div to 3 day/div	50 MW	5 kS/s
6 to 11 channels	6 s/div to 3 day/div	50 MW	10 kS/s
4 to 5 channels	3 s/div to 3 day/div	100 MW	20 kS/s
3 channels	2 s/div to 3 day/div	250 MW	50 kS/s
2 channels	1 s/div to 3 day/div	500 MW	100 kS/s
1 channel	1 s/div to 3 day/div	1 GW	100 kS/s

Realtime recording is possible within the maximum record length and maximum sample rate ranges of the number of channels to be realtime recorded.

The setting shown above is common to all models (memory options standard, M1, M2, and M3).

**Realtime Recording Mode**

If you select Single, the following two trigger modes are available. If you select Continue, only Log is valid.

**Auto:** Acquisition is started by pressing START. If the specified record length is exceeded, old data is overwritten. Acquisition continues until you press STOP.

**Log:** Acquisition is started by pressing START. When the specified record length is reached, acquisition stops.

**Sequence/Count**

**Single:** Acquisition is started by pressing START. When the specified record length is reached, acquisition stops.

**Continue:** Acquisition is started by pressing START. When the specified record length is reached, acquisition stops. This sequence is repeated the specified number of times (count).

**Auto Naming**

File names are automatically created during realtime recording. You can also enter comments. The following three auto naming types are available.

- **OFF**  
File name specified by File Name (up to 16 characters).
- **Numbering**  
Automatically creates files by attaching a four-digit number, 0000 to 4999, to the file name. You can assign a common name before the number (Specified with File Name. Up to 4 characters).

## 7.7 Realtime Recording to the Internal Hard Disk (Optional)

---

- **Date**

Automatically creates files using the date and time for the file names. (The file name specified by File Name is void.)

Selecting Date is convenient for file management, because the file names do not overlap.

### **Executing the Realtime Recording**

When you press START/STOP, realtime recording is started. After recording for the specified time, the operation stops.

### **Aborting the Realtime Recording**

Press START/STOP to abort the waveform acquisition. Realtime recording is aborted even if it is within the specified recording time.

### **Saving and Loading the Waveform Data That Has Been Realtime Recorded**

For details, see section 13.14, "Loading/Converting Realtime Recorded Waveform Data."

### **Notes When Realtime Recording**

- Realtime recording is not possible when the acquisition mode is set to Average.
- During realtime recording, only the executing/aborting of the realtime recording, zoom display setting, and protection function are valid.
- Realtime recording is possible only when the trigger mode is set to Auto or Log.
- Cursor measurements and automated measurement of waveform parameters are suspended when realtime recording is in progress.
- History memory waveforms, recalled waveforms, and computed waveforms cannot be displayed when realtime recording is in progress.
- The following operations are possible on the data that is realtime recorded to the hard disk (history memory function cannot be used).
  - Cursor measurement and automated measurement of waveform parameters (up to 10 MW)
  - Zooming on the Waveform
  - Various computations
  - X-Y display (uses compressed data)
  - Saving/Loading of waveform data
  - Printer output
- When realtime recording to the internal hard disk, do not connect a PC to the SCSI connector.
- Realtime recording is not possible when action-on-trigger is ON or when the dual capture function is in use.
- Realtime recording is not possible if the record length is less than 1 MW.
- Key response slows down when realtime recording is in progress.
- The maximum number of files that can be created in the realtime recording area of the internal hard disk is 128. If the number of files reach 128, delete unneeded files by operating the DL750/DL750P. You can also copy the files to an area outside the realtime recording area of the internal hard disk or to other storage media.
- Zoom waveforms can be displayed using the ZOOM menu when realtime recording is in progress. However, there is a limitation on the magnification (Zoom Mag) depending on the record length.

---

<b>Record Length</b>	<b>Possible Zoom Mag</b>
1 MW to 10 MW	T/div in which the number of displayed points is 250 k or more
25 MW	T/div in which the number of displayed points is 500 k or more
50 MW	T/div in which the number of displayed points is 1 M or more
100 MW to 1 GW	T/div in which the number of displayed points is 2.5 M or more

---

### **CAUTION**

- If the power is cut off when realtime recording is in progress, a disk area that cannot be freed may result in the realtime recording area or the internal hard disk may be damaged.

If a disk area that cannot be freed results, the disk performance in the realtime area may deteriorate. Consequently, realtime recording may not operate properly. In this case, back up the required data on the internal hard disk and format the internal hard disk.

- Do not expose the DL750/DL750P to shock when realtime recording is in progress. The internal hard disk may get damaged or the realtime recording may not operate properly.
- An icon  in the upper left part of the screen blinks when realtime recording is in progress. Do not remove or insert the USB storage device\* connected to the USB connector (for peripherals) while the icon is blinking. The DL750/DL750P may stop functioning properly, or data may become corrupted during realtime recording.

\* A memory device connected to a USB connector such as an MO disk drive, hard disk, or flash memory.

- The Real Time drive is a working area on the DL750/DL750P internal hard disk for realtime recording.

Never delete files from the drive or add files to the drive from an external PC such as by using the FTP server function.

If you do, the realtime recording may not operate properly.

---

### **Note**

For the procedure in saving the data, see section 13.14.

---

## 7.8 Setting the Action When Waveform Display Is Updated (Action-on-Stop)

<For a description of this function, refer to page 2-36.>

### Procedure

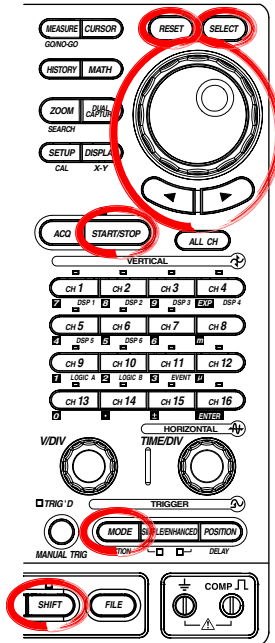

1. Press **SHIFT+MODE** to display the ACTION menu.

### Setting the Action

2. Press the **Mode** soft key to display the Mode setup menu.
3. Press the **On Stop** soft key.
4. Press the **Action** soft key to display the Action setup menu.
5. Use the **jog shuttle** and **SELECT** to select action to be enabled. (You can select multiple actions.)
6. If you selected Save to File in step 3, use the **jog shuttle** and **SELECT** to set the file save format to Binary, ASCII, or Float. If you selected Send Mail, use the **jog shuttle** and **SELECT** to set Mail Count.

### Setting the Number of Actions

7. Press the **Sequence** soft key to select Single or Continue.
8. Press the **ACQ Count** soft key.
9. Turn the **jog shuttle** to set the number of actions. Pressing **RESET** resets the count Infinite.







### Setting the Execution Mode of the Action-on-Stop at Power ON

10. Press **MISC**.
11. Press the **Next 1/2** soft key
12. Press the **Others** soft key.
13. Press the **Action Mode (Power ON)** soft key to select ON or OFF.

### Executing the Action-on-Stop

14. Press **START/STOP**. Waveform acquisition is started, and action-on-stop is executed. While action-on-stop is in execution,  is displayed in the upper left corner of the screen.

In addition, if the following action is specified, the following icon is displayed in the upper left corner of the screen while the action is being executed.

Image/Save to File: Save destination medium ( FD,  Zip disk,  PC card,  SCSI device,  internal HD,  network drive, or  USB storage device)

Send Mail: 

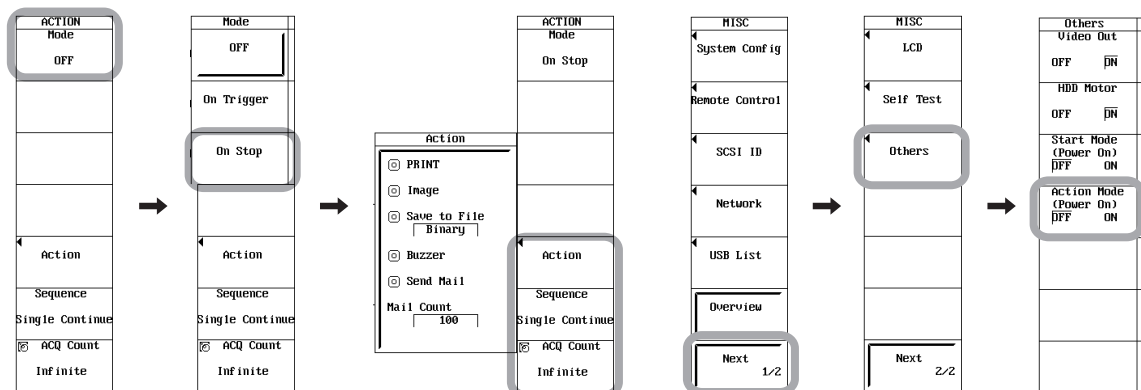

**Aborting the Action-on-Stop**

15. Press **START/STOP**. Waveform acquisition is stopped, and action-on-stop is aborted.

**Explanation****Setting the Mode**

The specified record length of data is acquired when measurement is started, and the waveform is displayed. Then, the specified action is executed. In addition, the specified action is also executed when measurement is stopped. When action-on-stop is enabled, the trigger mode is set to Log.

**Setting the Action**

The following five types of actions are available.

**Print the Screen Image Data: PRINT**

Prints the screen image data on the printer (Printer (built-in printer), USB (USB printer), Net Print (network printer)) specified by Print to in the PRINT menu.

**Save the Screen Image Data: Image**

Saves the screen image data to the destination (FD, Zip disk, PC card, internal HD (optional), SCSI device, or USB storage device) specified in the IMAGE SAVE menu.

**Save the Waveform Data: Save to File**

Saves the waveform data in binary, ASCII, or floating format to the destination (FD, Zip disk, PC card, internal HD (optional), SCSI device, or USB storage device) specified in the FILE menu. The save format is synchronized to data type (see section 13.7) on the FILE menu.

**Buzzer**

Sounds a buzzer.

**Send Mail**

Sends an e-mail message to a specified address (when Ethernet interface option is installed). Set the number of mail transmissions in the range of 1 to 1000.

For the procedure of setting the address, see section 16.5, "Sending Periodic Mail or Action Mail."

**Note**

If action-on-stop is executed, the data is acquired in Log mode regardless of the trigger mode setting, and the specified action is carried out. The specified action is also carried out when the measurement is stopped in the middle of the measurement.

**Setting the Number of Actions: Sequence****Sequence**

Single: Performs the action once.

Continue: Performs the action the number of times specified by ACQ Count.

**ACQ Count**

2 to 65536: Repeats the action the specified number of counts.

Infinite: Repeats the action until waveform acquisition is stopped.

**Save to File/Hard Copy/Image Operation**

Operates according to the settings in the FILE, PRINT, or IMAGE SAVE menu.

### **File Name When Action Is Set to Save to File or Image**

If the Auto Naming of the File menu or the Image Save menu is OFF, numbers are automatically assigned to the file names. Otherwise, the file is saved using the specified method.

For details, see section 13.11, "Saving the Screen Image Data" or section 13.7, "Saving/Loading Waveform Data."

### **Send Mail Operation**

Sends e-mail messages to the address specified using Network > Mail Setup > Mail Address in the MISC menu.

### **Setting the Execution Mode of the Action-on-Stop at Power ON: Action Mode (Power ON)**

You can select whether to enable action-on-stop at power-on. For example, turn this ON if you wish to continue the action-on-stop operation after a power failure.

ON: At power ON, the action-on-stop is set to the mode that was used when the power was turned OFF.

OFF: Action Mode is turned OFF at power ON.

The initial setting is OFF.

### **Notes When Using the Action-on-Stop**

- Action-on-stop cannot be used if the acquisition mode is Average.
- You cannot change the settings while the action-on-stop is in progress.
- The action-on-stop operation may slow down if there is access from the network while the following action is in progress.  
Printing/saving of the screen image data and saving of the waveform data
- You cannot use action-on-stop when the dual capture function is ON or when the realtime recording to the internal hard disk is ON.

### **Notes When Action Is Set to Save to File or Image Save**

- Do not specify the root directory of the medium as the save destination directory. (Only up to 512 files can be saved to the root directory of a medium that has been formatted using the DL750/DL750P.)
- The maximum number of files that can be created in a single directory is 5000. Do not place files in the save destination folder before starting the action-on-stop operation.
- If you select Save to File and Image Save simultaneously, separate the folders specified by the FILE menu and the IMAGE SAVE menu.
- If you selected Numbering for the file name assignment method (Auto Naming) in the FILE menu and the IMAGE SAVE menu, the creation of files takes an extended period when the number of saved files becomes large. When creating more than 2000 files, select Date for Auto Naming.
- When 5000 files are saved, the action-on-stop operation ends.



# 7.9 Using the Voice Memo Function

<For a description of this function, refer to page 2-36.>

This section describes only the voice memo function. For a description of the voice comment function, see section 13.19.

Before using the voice memo function, connect the earphone microphone with a PUSH switch to the DL750/DL750P by referring to section 3.14, "Connecting the Earphone Microphone with a PUSH Switch and Connecting the Speaker."

### Note

- The REC LEVEL and VOLUME knobs on the left side panel click in place at the center position. When using the earphone microphone with a PUSH switch, set the REC LEVEL and VOLUME knobs to the center position to obtain adequate recording level and play volume.
- If you are outputting the voice to an external speaker for the first time by using the optional speaker cable (sold separately), set the play volume to the minimum setting using the VOLUME knob.

### Procedure

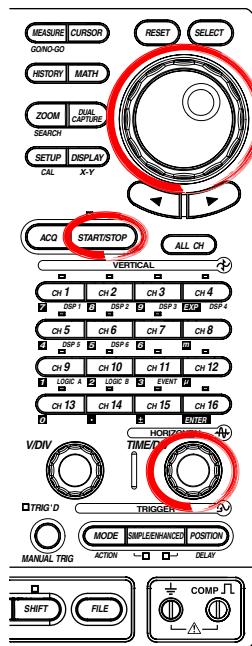
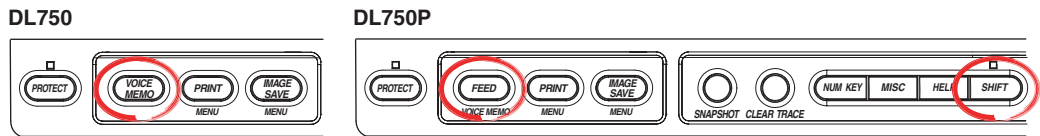

### Setting the Voice Memo Function

1. Press **VOICE MEMO**. (On the DL750P, press **SHIFT+FEED (VOICE MEMO)**.)
  2. Press the **Mode** soft key to select ON.
- **Turning ON/OFF the Event Waveform Display**
    3. Press the **Event Display** soft key to select OFF or ON. For a description of event waveforms, see section 5.21.
    4. Press the **Next 1/2** soft key.
  - **Setting the Record Time**
    5. Press the **Rec Time** soft key.
    6. Press the **Flexible** or **Fixed** soft key. If you wish to record for an arbitrary length of time without specifying the record time, select Flexible; if you wish specify the record time and count before recording, select Fixed. If you select Flexible proceed to step 8; if you select Fixed proceed to step 7.
    7. Use the **jog shuttle** to set the Time in the range of  $5\text{ s} * 20$  ( $5 \times 20$  times) to  $100\text{ s} * 1$  ( $100 \times 1$  time).

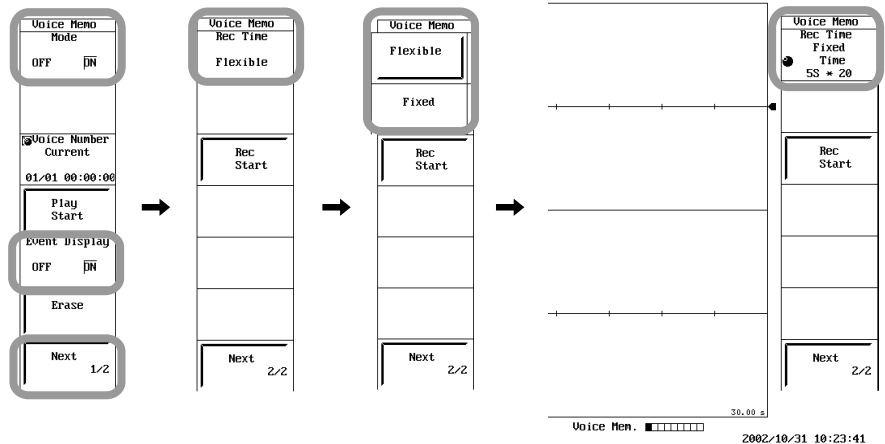

**Executing the Waveform Acquisition**

8. Turn TIME/DIV to set T/div in the range of 100 ms/div to 3 day/div.
9. Press **START/STOP**.

**Note**

If the ACQ MEMORY BACKUP switch (located on the DL750/DL750P right side panel) is turned ON, the voice memo data is backed up as with the waveform data. The backup procedure is the same as the backup function of the acquisition memory. See section 7.10.

**Recording a Voice Memo**

• **When Flexible Is Selected**

There are two record methods.

**Recording by Using the PUSH Switch on the Earphone Microphone**

10. Record the voice memo while holding down the PUSH switch on the earphone microphone.
11. To stop recording, release the PUSH switch. When the recording is finished, proceed to step 12.

**Recording Using the Voice Memo Menu**

10. Record the voice memo by pressing the **Rec Start** soft key. The soft key changes to Rec Stop.
11. To stop the recording, press the **Rec Stop** soft key. When the recording is finished, proceed to step 12.

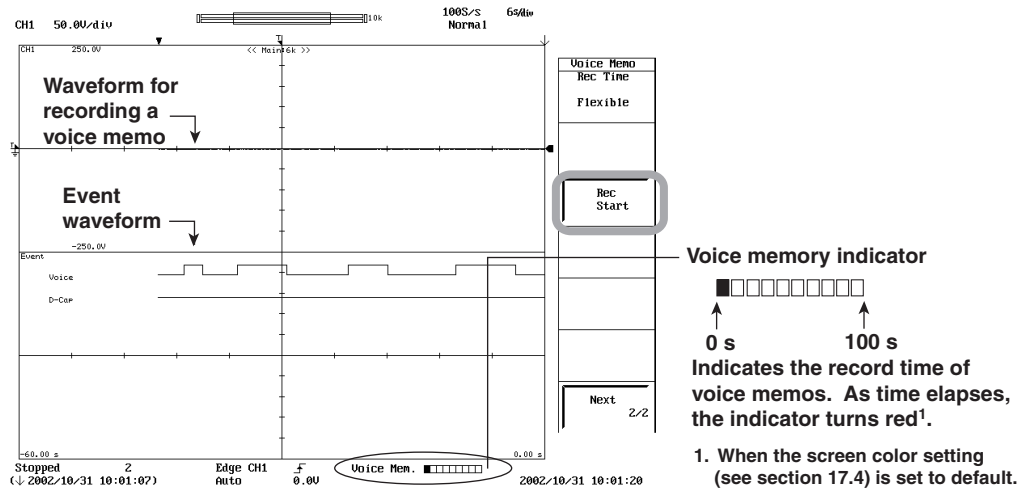

**Note**

- Voice memos can be recorded repeatedly until the total record time reaches 100 s.
- If the total record time reaches 100 s, succeeding recordings will be invalid. Refer to the voice memory indicator that is displayed at the lower right corner of the screen for the record time and record count.
- An icon  appears at the upper left corner of the screen while voice memo recording is in progress.

- **When Fixed Is Selected**

There are two record methods.

#### Recording by Using the PUSH Switch on the Earphone Microphone

10. Record the voice memo by pressing the PUSH switch on the earphone microphone. When the recording is finished, proceed to step 12.

#### Note

When Fixed is selected, the voice memo is recorded for the time specified by Rec Time by pressing the PUSH switch once. The PUSH switch does not have to be held down.

#### Recording Using the Voice Memo Menu

10. Record the voice memo by pressing the **Rec Start** soft key. The voice memo is recorded for the time specified by Rec Time. When the recording is finished, proceed to step 12.

#### Note

When Fixed is selected, the Rec Start soft key display does not change even while recording is in progress.

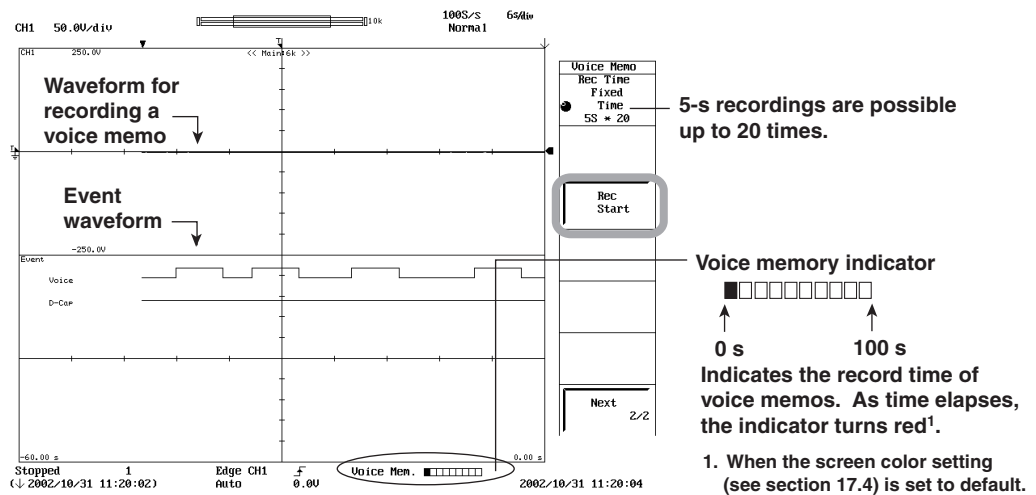

#### Note

- An icon  appears at the upper left corner of the screen while voice memo recording is in progress.
- Of the waveform data stored to the acquisition memory using the history memory function (see section 11.1), the voice memo data is stored only for the newest waveform data. Only event waveforms are stored for waveforms other than the newest waveform. Thus, voice memo cannot be played even if the waveform data is loaded using the history memory function.

#### Stopping the Waveform Acquisition

12. Press **START/STOP**. Waveform acquisition stops.

## 7.9 Using the Voice Memo Function

### Playing of the Voice Memo

13. Press the **Next 2/2** soft key.
14. Press the **Voice Number** soft key.
15. Use the **jog shuttle** to select the number of the voice data you wish to play.
16. Press the **Play Start** soft key. The voice memo of the specified number is played.

### Note

- Current indicates the newest voice memo (voice recorded on the rising edge of the event bit of the event waveform that is displayed at the right-most position on the screen). The oldest memo is indicated as #1. The voice memo is newer as the number gets larger.
- While the voice memo is being played, the soft key indication changes to Play Stop. To stop the voice memo while it is playing, press the Play Stop soft key.
- An icon  appears at the upper left corner of the screen while voice memo is being played.
- The voice memo can be played through a speaker by connecting an external speaker. For the procedure of connecting a speaker, see section 3.14.
- The voice memo can also be played using voice search of the SEARCH menu. For details, see section 11.4.

### Executing the Waveform Data Save Operation

17. Save the waveform data according to steps 1 to 25 in “Saving the Waveform Data” in section 13.7. The recorded voice memo is also saved.

### Executing the Waveform Data Load Operation

18. Load the waveform data according to steps 1 to 10 in “Loading the Waveform Data” in section 13.7. When waveform data with a voice memo is loaded, the voice memo can be played. The procedure of playing the voice memo is the same as steps 13 to 16 in this section.

### Note

To determine whether a voice memo is attached to the waveform data, open the properties of the waveform data (see section 13.7) using FILE key > Load > Property. If the VOICE MEMO item in the properties is ON, a voice memo is attached to the waveform data, otherwise a voice memo is not attached.

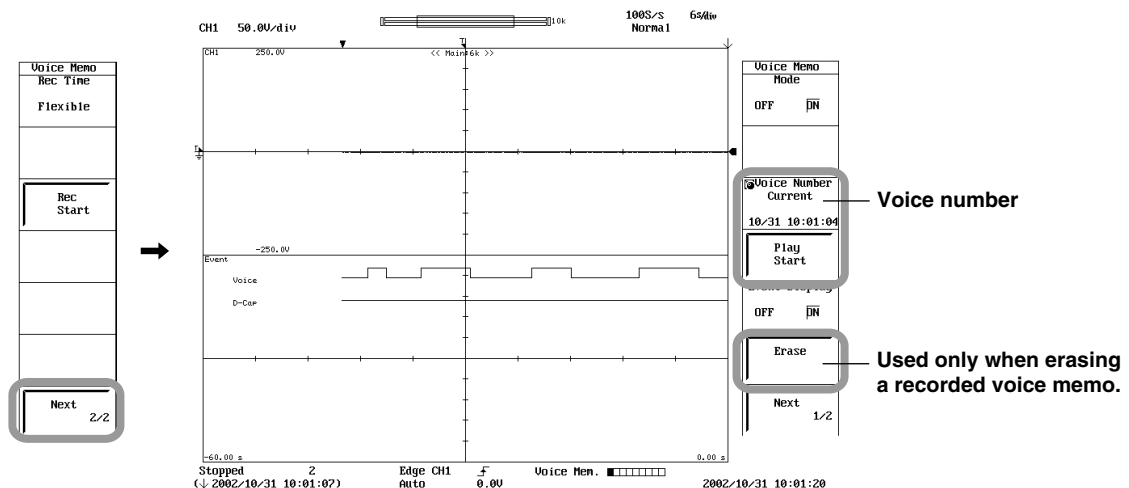

### Erasing Voice Memos

The recorded voice memo can be erased. This operation is performed when a voice memo was recorded while waveform acquisition was in progress, but you wish to save the waveform data without the voice memo.

After step 16 of this section, press the **Erase** soft key. The voice memo is erased, and the voice memory indicator value on the screen is cleared.

### Note

Once a voice memo is erased, it cannot be recovered. Use caution when erasing a voice memo.

### Explanation

A voice memo can be recorded while waveform acquisition is in progress (when in roll mode display) by connecting an earphone microphone with a PUSH switch to the DL750/DL750P.

### Setting the Mode

To enable the voice memo function, set Mode to ON.

When turned ON, a voice memory indicator is displayed at the lower right corner of the screen.

### Displaying Event Waveforms

The event waveform (Voice bit of the event waveform) indicates the record interval of the voice memo. The interval during which a voice memo is recorded is from the rising edge to the falling edge of the event waveform. For the procedure of setting event waveforms, see section 5.21.

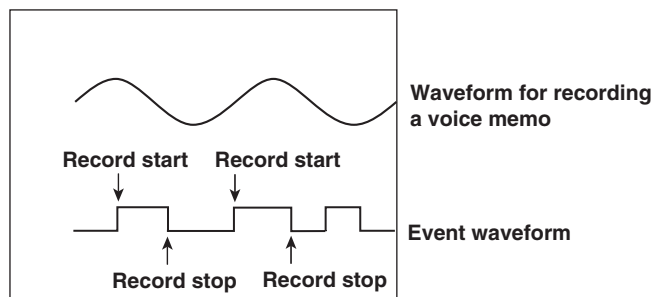

### Precautions Regarding the Voice Memo Function

- If the record length setting is set long in the ACQ menu causing the number of channels that can be used to 3 channels or less, event waveforms are not displayed. In this case, the voice memo function cannot be used.
- If the voice memo function is OFF (Mode: OFF) even when the event waveform display is ON (Event Display: ON), event waveforms are not saved when waveform data is saved. In addition, even if a voice memo is recorded during waveform acquisition, if the voice memo function is turned OFF at the time waveform data is saved, event waveform data/voice data will not be saved.
- In realtime recording, if the valid number of channels<sup>1</sup> is 3 channels or less, event waveforms cannot be used. In this case, the voice memo function cannot be used.
  1. Valid number of channels signify the number of channels that are turned ON excluding MATH1 to MATH8 channels. However, for LOGIC A and LOGIC B, the number of channels is counted as 1 regardless of whether one of the channels is ON or both channels are ON.

### **Rec Time**

Recording is possible up to a total of 100 s.

The following two methods are available in setting the record time.

### **Flexible**

Recording continues while the PUSH switch on the earphone microphone is held down or from the time when the Rec Start soft key of the Voice Memo menu is pressed until the Rec Stop soft key is pressed. To stop the recording, release the PUSH switch or press the Rec Stop soft key. The shortest record time of one session is 3 s. (Even if the record stop operation is performed within 3 s of starting the recording, recording continues for 3 s.)

### **Fixed**

Recording is performed for the specified time and count (the combination of time and count is bound to 100 s total). Once the PUSH switch or the Rec Start soft key of the Voice Memo is pressed, recording is performed for the specified length of time. When using the PUSH switch, the PUSH switch does not have to be held down.

The combination of record time and record count can be selected from the following:

5 s \* 20, 10 s \* 10, 20 s \* 5, 25 s \* 4, 50 s \* 2, and 100 s \* 1

For example, if you select 5 s \* 20 and press the PUSH switch once, recording is performed for 5 s. Press the PUSH switch again to record another 5 s. The record operation can be repeated up to 20 times.

### **Playing the Voice Memo: Voice Number and Play Start**

Use the Play Start soft key to play the voice memo specified by Voice Number.

Use Voice Number to specify the number of the voice memo you wish to play. Current indicates the newest voice memo. The oldest memo is indicated as #1. The voice memo is newer as the number gets larger. The date/time displayed below Voice Number is the date/time when the voice memo recording was started.

### **Erasing Voice Memos**

The recorded voice memo is erased. Use caution because voice memos that are erased cannot be recovered.

### **Note**

- The search and zoom function (see section 11.4) can be used to search the section of the waveform data where a voice memo is recorded (voice search). Playing the voice memo that has been found is also possible. For a description of the voice search function, see section 11.4.
  - The data size of waveform data with a voice memo increases as compared to waveform data without a voice memo. For example, if a voice memo is recorded for 100 s and saved, the data size increases by approximately 440 KB.
-

## 7.10 Using the Acquisition Memory Backup Function

<For a description of this function, refer to page 2-36.>

The data held in the acquisition memory can be backed up immediately before the power is shut down even if the power supply is cut off due to reasons such as a sudden power failure.

### Data That Is Backed Up

- Waveform data
- History memory data
- sub window data of the dual capture function
- Voice memo data

### Backup Batteries

#### Type of Batteries That Can Be Used

- AAA alkaline dry cells (AA/R6) (JIS, IEC model: LR6): 4 cells
- Nickel hydride rechargeable batteries: 4 cells

#### Battery Storage

The battery storage box is located on the right side of the top panel.

1. Lift the handle and remove the screws from the battery storage box using a screwdriver.
2. Remove the storage box cover, and insert four batteries paying attention to their direction.
3. Set the storage box cover back to the original place and fasten the screws.

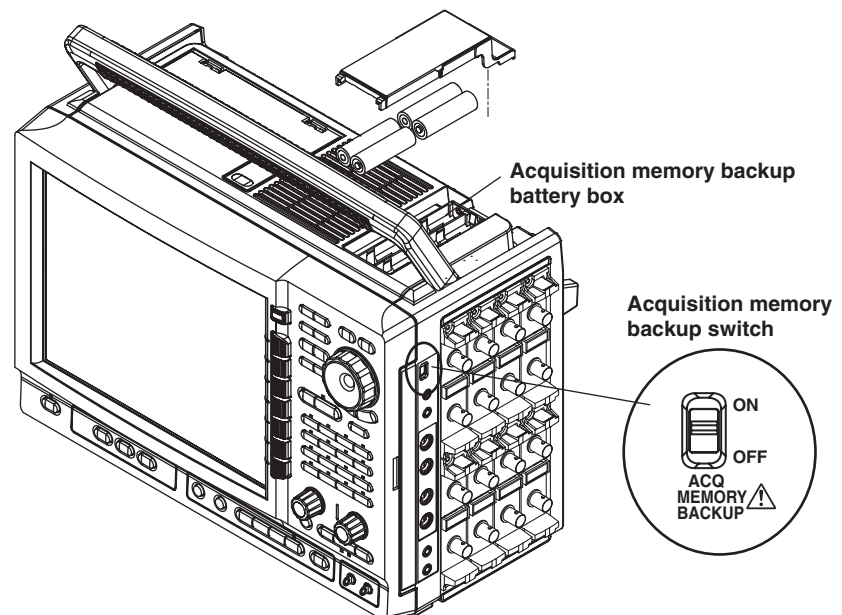

## 7.10 Using the Acquisition Memory Backup Function

---

### Backup Procedure

1. Turn ON the acquisition memory backup switch on the right side panel of the DL750/DL750P. The acquisition memory backup starts.
2. To stop the acquisition memory backup, turn OFF the acquisition memory backup switch.

The backup time varies depending on the operating environment. See section 19.5.

### **Note**

---

- When using the nickel hydride rechargeable batteries, be sure to charge them before use. (The DL750/DL750P does not have a charge function.)
  - You cannot check the battery level on the DL750/DL750P. Use a commercially sold battery level checker or other similar devices.
  - For a description of the backup operation, see appendix 9.
-



# 8.1 Changing the Display Format

<For a description of this function, refer to page 2-37.>

## Procedure

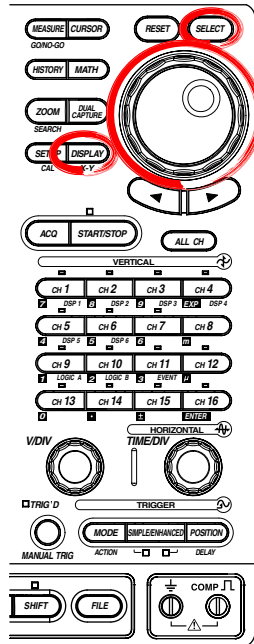

1. Press **DISPLAY**.

### Setting the Display Format

2. Press the **Format** soft key. The format selection menu appears.
3. Press the soft key corresponding to the desired format from Single (one division) to Hexadecimal (16 divisions).

### Setting the Waveform Mapping

4. Press the **Next 1/2** soft key.
5. Press the **Mapping** soft key to select Auto, Fixed, or User. If you select User, proceed to step 6.
6. Press the **Set Mapping** soft key. The waveform mapping setup menu appears.
7. Use the **jog shuttle** and **SELECT** to set the mapping number of each channel.

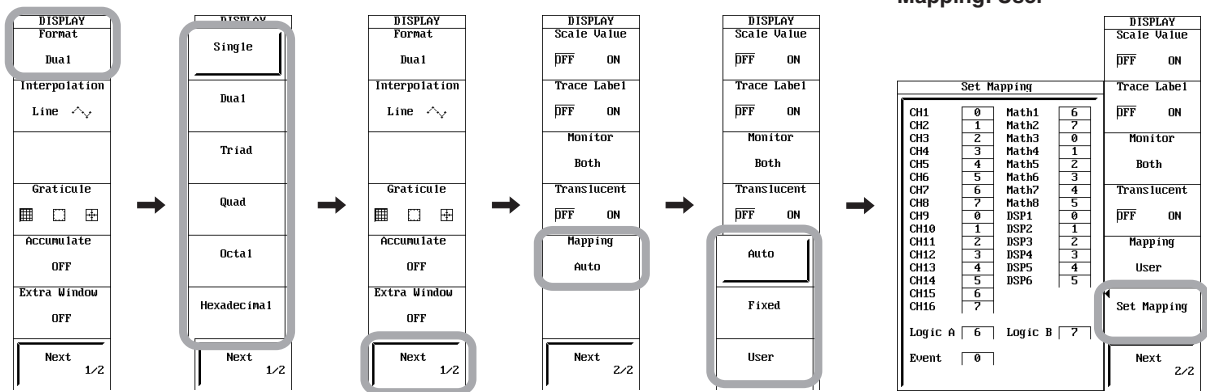

DSP1 to DSP6 are optional.

## 8.1 Changing the Display Format

---

### Explanation

You can select the number of windows into which the analog waveform display window is divided. The position of the waveform of each channel varies depending on the display format.

#### Display Format

Single: 1 window	Quad: 4 windows
Dual: 2 windows	Octal: 8 windows
Triad: 3 windows	Hexadecimal: 16 windows

#### Waveform Mapping

- **Auto**

Windows are arranged from top to bottom in order: CH1, CH2, ... , CH16, DSP1 to DSP6 (optional), Math1 to Math8. But no windows are shown for channels whose display is set to OFF.

- **Fixed**

Channels that are set to OFF are also mapped.

- **User**

Assign numbers from 0 to 7 to CH1, CH2, ... , CH16, DSP1 to DSP6 (optional), Math1 to Math8. The display position varies depending on the assigned numbers.

#### Mapping Example When Display Format Is DUAL

CH1, CH2, CH4	CH1, CH4 CH2,	0, 2, 4 1, 3, 5
<b>Fixed</b> (When CH3, CH5 to CH16 = OFF)	<b>Auto</b> (When CH3, CH5 to CH16 = OFF)	<b>User</b> (When CH6 to CH16 = OFF)

The number of points that can be displayed vertically (10 divisions) for each channel varies as follows according to the display format. However, the vertical resolution remains unchanged.

Single(□): 512 points	Quad(☐): 128 points
Dual(☐): 256 points	Octal(☐): 64 points
Triad(☐): 170 points	Hexadecimal(☐): 32 points

## 8.2 Setting the Display Interpolation Method

<For a description of this function, refer to page 2-37.>

### Procedure

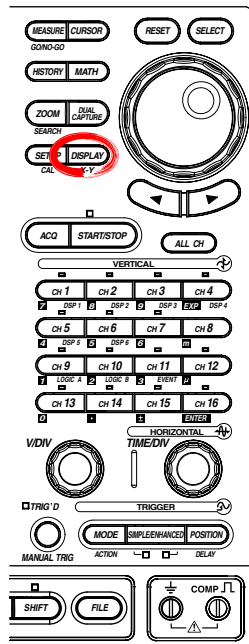

1. Press **DISPLAY**.

### Setting the Interpolation Method

2. Press the **Interpolation** soft key. The interpolation selection menu appears.
3. Press the soft key corresponding to the desired interpolation method from **OFF**, **Sine**, and **Line**.  
If you select OFF, proceed to step 4.

### Setting the Number of Data Points to Be Used for Waveform Display

4. Press the **Decimation** soft key to select the number of points to be used for the display from 2k and 100k.

### Note

Decimation specifies the number of dots when interpolation is turned OFF. For example, if the record length is 100 kW and Decimation is set to 2k, data is extracted at constant intervals. Waveform is displayed using 2 kW of data. If Decimation is set to 100 k, the waveform is displayed using all 100 kW of data.

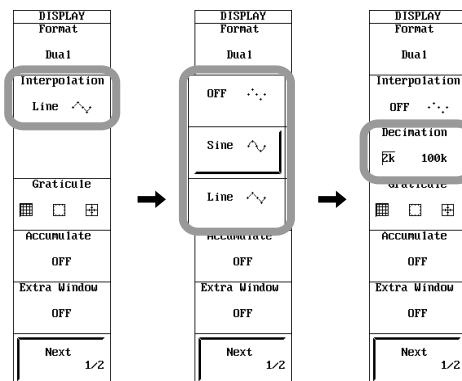

### Explanation

#### Setting the Interpolation Method

Any area along the time axis having less than 1000 points in 10 divisions (less than 500 points in the Z1 and Z2 window when displaying Main & Z1 & Z2) is recognized as an interpolation area. If you leave interpolation off, these points will appear as discrete dots (so that the display will show gaps between dots or vertical lines).

If you set interpolation on, however, the DL750/DL750P will connect the points. Three following interpolation methods are available.

Sine(📈): Interpolates between two points using the  $\sin(x)/x$  function.

Line(—): Linearly interpolates between two points.

OFF(•••): No interpolation.

#### When the Area Is Not an Interpolation Area

If interpolation is set to Sine or Line, the instrument draws lines between points that are aligned vertically.

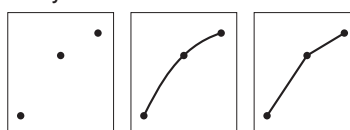

Interpolate:      **OFF**              **Sine**              **Line**

## 8.2 Setting the Display Interpolation Method

- **When the Area Is Not an Interpolation Area**

If interpolation is set to Sine or Line, the instrument draws lines between points that are aligned vertically. If the number of data points is greater than or equal to 2002, P-P compression is performed (maximum and minimum values are determined at certain intervals), and two points are displayed on a single vertical line (1 raster).

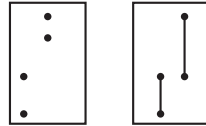

Interpolate:    **OFF**        **Sine/Line**

### **Setting the Number of Data Points to Be Used for Waveform Display: Decimation**

When the area is not an interpolation area on the T-Y waveform display and Interpolation is set to Sine or Line, the aforementioned P-P compressed values are displayed. However, if Interpolation is set to OFF or if X-Y waveforms are being displayed, the acquisition data is decimated and data that has been picked up at certain intervals are displayed.

Set the number of data points for displaying the waveform to 2k or 100k.

If 2k is selected and the record length is greater than or equal to 2 kW, the data is decimated to 2 kW, and two points are displayed on one vertical line. If 100k is selected and the record length is greater than or equal to 100 kW, the data is decimated to 100 kW, and 100 points are displayed on one vertical line. Otherwise, all points are displayed.

If the number of data points per division is greater than or equal to 100 for a realtime recorded waveform or when in roll mode, the maximum and minimum values at certain number of data points of acquisition data are displayed using linear interpolation.

### **Data Interpolation and Envelope Mode**

When the acquisition mode is envelope, the data is interpolated using an area regardless of the specified interpolation method (see the following figure). This is because in envelope mode the maximum and minimum values are determined over a certain interval, and the data time position cannot be pinpointed.

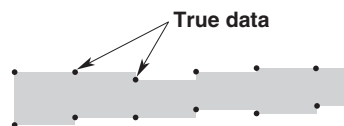

# 8.3 Changing the Graticule

<For a description of this function, refer to page 2-38.>

## Procedure

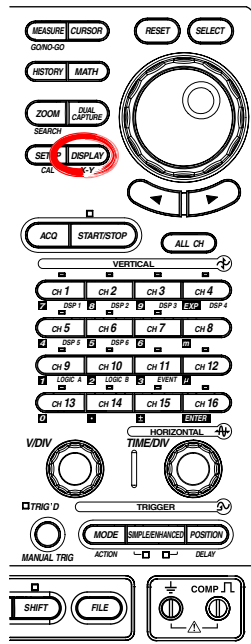

1. Press **DISPLAY**.
2. Press the **Graticule** soft key to select the graticule.

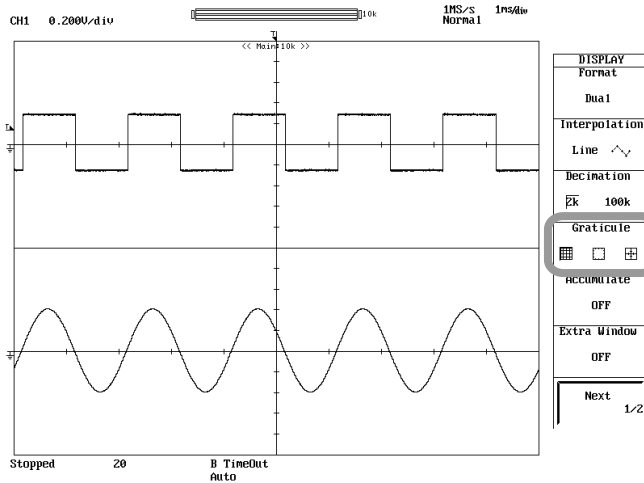

## Note

On the DL750P, the graticule setting is linked to the RECORDER menu > Print Setup > Graticule setting. However, if  is selected, it is set to OFF in the RECORDER menu.

## Explanation

Select the graticule from the following three types.

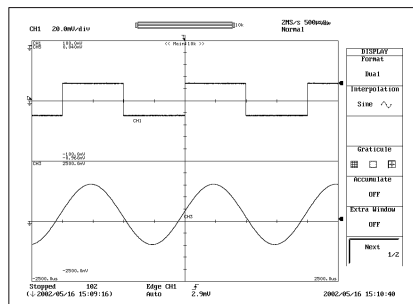
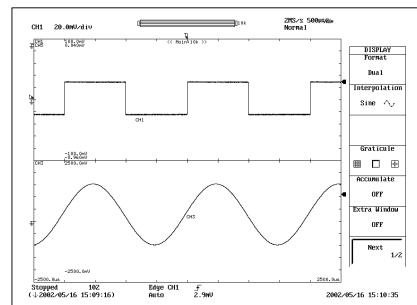
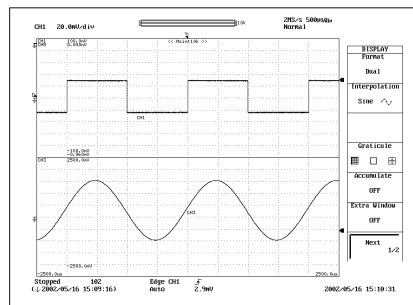

# 8.4 Accumulated Waveform Display

<For a description of this function, refer to page 2-38.>

## Procedure

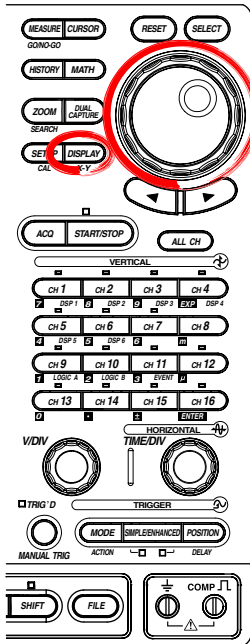

### Setting the Accumulate Mode

1. Press **DISPLAY**.
2. Press the **Accumulate** soft key. The accumulate mode selection menu appears.
3. Press the **OFF** or **Persist** soft key to select the accumulate mode. If you select Persist, proceed to step 4.

### Setting the Accumulate Time

4. Turn the **jog shuttle** to set the Count in the range of 2 to 128 (2<sup>n</sup> step).

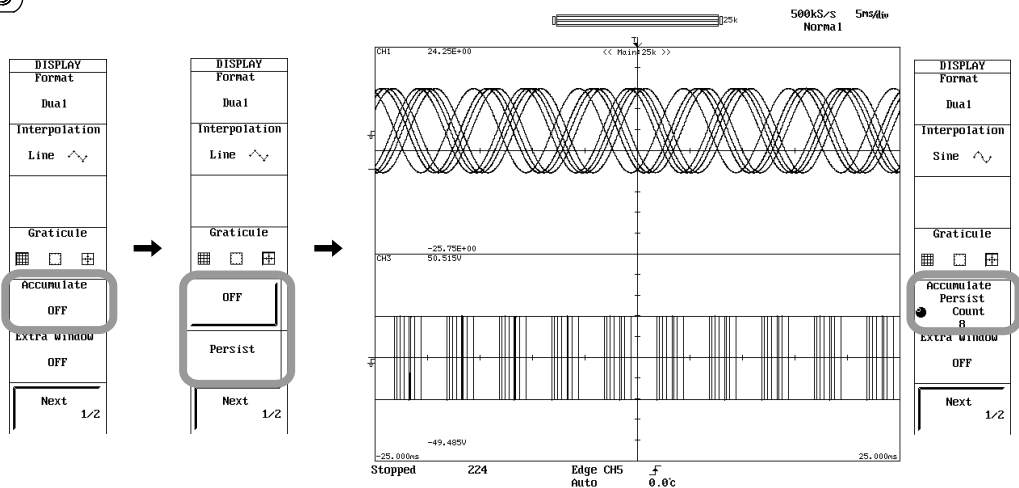

## Explanation

Normally, the display is updated every time the trigger is activated making it difficult to capture transient conditions such as sudden distortion of waveforms. By using the accumulate function, the waveform display of the acquired data remains on the screen for the specified time.

### Accumulate Mode

Persist: Persistence mode. Accumulates in red. Displayed for the specified time period by gradually lowering the brightness.

### Accumulate Period: Count

When using persistence mode, set the number of times to accumulate the waveform in the range of 2 to 128 (in  $2^n$  steps). If you select Infinite, the accumulation is carried out infinitely. The default value is 16.

### Notes When Using Accumulation

- Automated measurement of waveform parameters and GO/NO-GO determination are performed on the newest waveform.
- When printing accumulated waveforms using the built-in printer, they are printed using two tones.
- If the waveform acquisition is forcibly stopped by pressing START/STOP, the accumulation is temporarily suspended. When the acquisition is restarted, the display is cleared and accumulation continues.
- You cannot change the parameters on the HISTORY menu when accumulating waveforms on the display.
- Accumulated display is not possible in roll mode display.
- When you turn OFF the accumulate mode, accumulated waveforms are cleared. To display the acquired waveforms again, specify the record number on the HISTORY menu.
- If you display the waveforms again by setting the accumulate mode to Persist, the accumulated waveforms are not cleared. To clear them, execute CLEAR TRACE.
- Even if you change the display format during accumulated display, the waveforms that are already displayed accumulated are not cleared. To clear them, execute CLEAR TRACE.

### Clearing Accumulated Waveforms

You can clear accumulated waveforms by pressing the CLEAR TRACE key.

# 8.5 Zooming the Waveform

<For a description of this function, refer to page 2-41.>

## Procedure

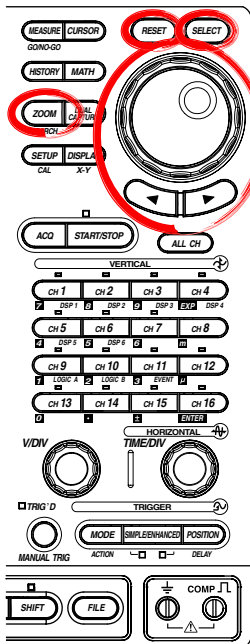

### Selecting the Display Mode

1. Press **ZOOM**.
2. Press the **Mode** soft key. The display mode selection menu appears.
3. Press the soft key corresponding to the desired mode.  
If you select Main, you cannot carry out the following operations.

### Selecting the Display Format of Zoomed Waveforms

4. Press the **Format** soft key. The format selection menu appears. (If you set Mode to Main, the Format selection menu is not displayed.)
5. Press the soft key corresponding to the desired format.

### Setting the Waveform to Be Zoomed

6. Press the **Allocation** soft key. The menu for setting the waveform to be zoomed appears.
7. Use the **jog shuttle** and **SELECT** to select the waveform to be zoomed. Select All ON to select all waveforms that are currently displayed.

### Setting the Zoom Rate

8. Press the **Z1 Mag/Z2 Mag** soft key to set the **jog shuttle** control to Z1 Mag. (If you set Mode to Z1, Z1 Mag is displayed. If you select Z2, Z2 Mag is displayed. If you select Z1 and Z2, Z1 Mag/Z2 Mag is displayed.) Turn the **jog shuttle** to set the zoom rate of the Z1 zoom box.
9. Likewise set the zoom rate of the Z2 zoom box with Z2 Mag.

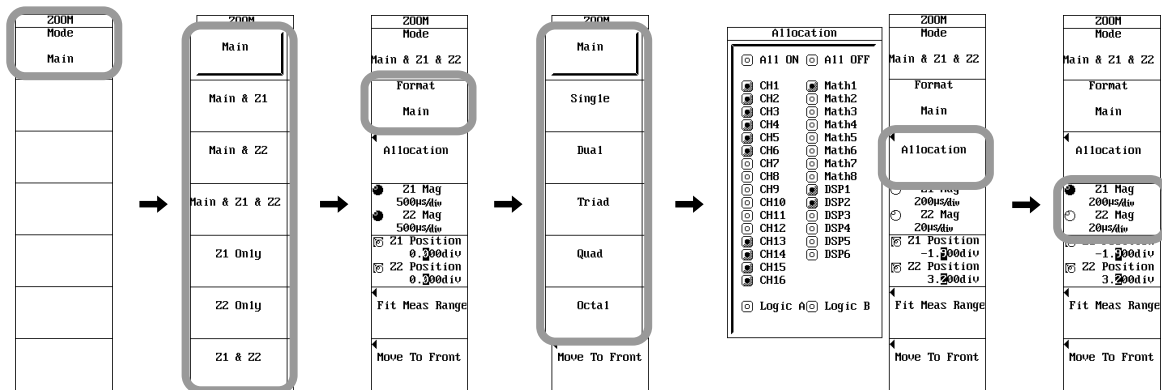

DSP1 to DSP6 are optional.



### Setting the Zoom Position

10. Press the **Z1 Position/Z2 Position** soft key to set the **jog shuttle** control to Z1 Position. (If you set Mode to Z1, Z1 Position is displayed. If you select Z2, Z2 Position is displayed. If you select Z1 and Z2, Z1 Position/Z2 Position is displayed.) Turn the **jog shuttle** to set the zoom position of the Z1 zoom box.
11. Likewise set the zoom position of the Z2 zoom box with Z2 Position. By setting the jog shuttle control to both Z1 Position and Z2 Position, the zoom positions of both Z1 and Z2 can be moved simultaneously.

### Changing the Range of the Automated Measurement of Waveform Parameters

- **When Mode is set to a setting other than Main&Z1&Z2**

12. Press the **Fit Meas Range to Z1** or **Fit Meas Range to Z2** soft key. The range of the automated measurement of waveform parameters is set to the zoom range of Z1 or Z2. Proceed to step 15.

- **When Mode is set to Main&Z1&Z2**

12. Press the **Fit Meas Range** soft key.
13. Press the **Fit to Z1** or **Fit to Z2** soft key.

### Moving the Zoom Box to the Head Position of the Waveform

- **When Mode is set to a setting other than Main&Z1&Z2**

14. Press the **Move Z1 to Front** or **Move Z2 to Front** soft key. The zoom box moves to the head position of the waveform.

- **When Mode is set to Main&Z1&Z2**

14. Press the **Move to Front** soft key.
15. Press the **Z1 to Front** or **Z2 to Front** soft key.

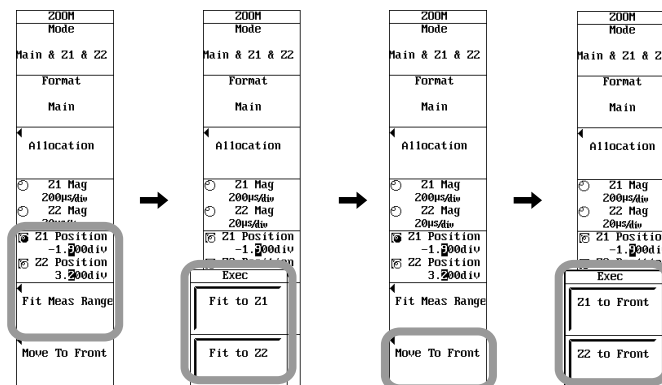

**Explanation**

Zoomed waveforms of two locations can be displayed simultaneously (dual zoom). You can also specify which channels to zoom. Zooming is not possible if the number of points displayed on the screen is less than or equal to 10 points (less than or equal to 50 for FFT waveforms).

**Selecting the Display Mode of Zoomed Waveforms**

- Main: Displays only the main (unzoomed) waveform.
- Z1 Only: Displays only the zoomed waveform of zoom box Z1.
- Z2 Only: Displays only the zoomed waveform of zoom box Z2.
- Main&Z1: Displays the main waveform in the top window and zoomed waveform of zoom box Z1 in the bottom window.
- Main&Z2: Displays the main waveform in the top window and zoomed waveform of zoom box Z2 in the bottom window.
- Z1&Z2: Displays the zoomed waveform of zoom box Z1 in the top window and the zoomed waveform of zoom box Z2 in the bottom window.
- Main&Z1&Z2: Displays the main waveform in the top window, the zoomed waveform of zoom box Z1 in the lower left window and the zoomed waveform of zoom box Z2 in the lower right window.

**Note**

On the DL750P, the range of zoom box Z2 can be printed expanded on the built-in printer (zoom print). For details, see section 12.2.

**Selecting the Zoomed Trace: Allocation**

The traces whose Allocation is turned ON are zoomed. If the allocation is OFF, the trace is not zoomed. You cannot allocate channels whose display is turned OFF.

**Display Format of Zoomed Waveforms**

Similar to the main waveform, 6 types (Main<sup>1</sup>, Single, Dual, Triad, Quad, Octal, Hexadecimal) of display formats are available. You cannot set different formats for Z1 and Z2.

- 1. Selecting Main results in the same format as Main Format in the DISPLAY menu .

**Zoom Rate: Z1 Mag/Z2 Mag**

- Sets the T/div of the zoom waveform display area.
- If the time base is set to an external clock signal, select the magnification from the following:  
 $\times 2, \times 2.5, \times 5, \times 10, \times 25, \times 50, \times 100, \times 250, \times 500, \times 1000, \times 2500, \dots$  , ten-fold multiples of 1, 2.5, 5, up to  $\times 1000000$
- The maximum zoom rate varies depending on the display record length.  
 Maximum zoom rate:  $\text{Display record length} \div 10$
- The maximum magnification during realtime recording with respect to the display record length of the main waveform is as follows:

Main Waveform Record Length	Record Length of the Zoom Window
1 MW to 10 MW	250 kW
25 MW	500 kW
50 MW	1 MW
1000 MW or more	2.5 MW

- The display record length does not necessarily match the record length.  
 For details on the display record length, see appendix 1, "Relationship between the Time Axis Setting, Sample Rate and Record Length."
- You can set different zoom rates for Z1 and Z2 (zoomed waveform of two locations).

**Zoom Position: Z1Position and Z2Position**

- The zoom position can be set by specifying the zoom center position (center of the zoom box) in the range –5 to +5 divisions with the center of the waveform display frame set to 0 divisions. The resolution is as follows:  
Selectable steps of zoom position:  $T/div \times 10 \div \text{display record length}$
- The zoom box enclosed by solid lines is Z1 and the one enclosed by dashed lines is Z2. Since each box is independent, you can set the position separately.

**Changing the Range of the Automated Measurement of Waveform Parameters:****Fit Meas Range to Z1/Fit Meas Range to Z2**

Sets the range of the automated measurement of waveform parameters to the zoom range of Z1 or Z2. This is valid even if the automated measurement of waveform parameters is turned OFF.

**Moving the Zoom Box to the Head Position of Waveform: Z1 to Front/Z2 to Front**

Moves the zoom box of Z1 or Z2 to the head position of the main waveform.

# 8.6 Displaying X-Y Waveforms

<For a description of this function, refer to page 2-40.>

## Procedure

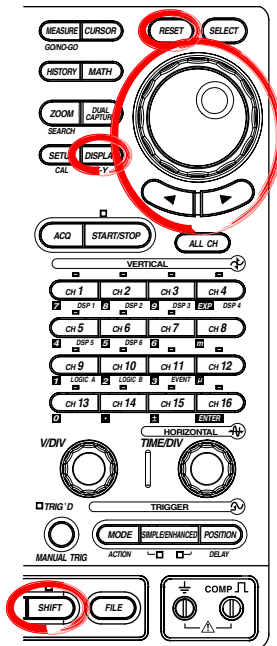

1. Press **SHIFT+DISPLAY**. The X-Y menu appears.

### Selecting the Display Mode

2. Press the **Mode** soft key. The mode selection menu appears.
3. Press the **T-Y**, **X-Y**, or **T-Y&X-Y** soft key to set the mode.

### Setting the Number of Data Points to Be Used for Waveform Display

4. Press the **Decimation** soft key to select the number of points to be used for the display from 2k and 100k.

### Selecting the X Axis Mode (When Mode Is Set to X-Y or T-Y&X-Y)

5. Press the **X Axis** soft key to select Single or Quad.  
If you select Single proceed to step 8; if you select Quad proceed to step 6.
6. Press the **Select** soft key. The X-Y waveform selection menu appears.
7. Press the soft key corresponding to the desired X-Y waveform from **XY1** to **XY4**.

### Setting the X Axis

8. Press the **X Trace** soft key. The channel selection menu appears.
9. Use the  **jog shuttle** and **SELECT** to select the channel to be assigned to the X axis. If you set X Axis to Quad, proceed to step 10.

### Setting the Y Axis (When X Axis Is Set to Quad)

10. As with the X axis, press the **Y Trace** soft key to set the Y axis.

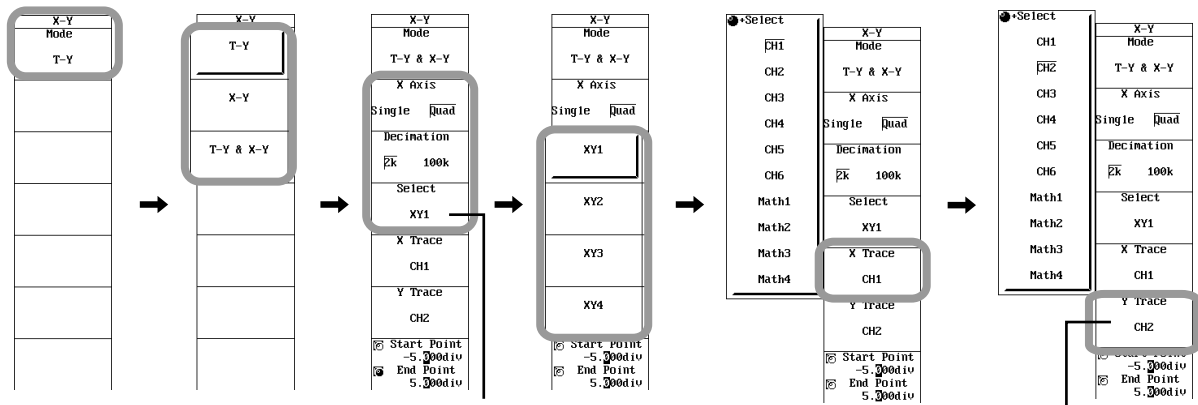

When X Axis: Quad

DSP1 to DSP6 are optional. When X Axis: Quad

**Setting the Display Range**

11. Press the **Start Point/End Point** soft key to set the jog shuttle control to Start Point.
12. Turn the **jog shuttle** to set the start point of the X-Y waveform display.
13. Likewise, press the **Start Point/End Point** soft key to set the jog shuttle control to End Point and set the end point of the X-Y waveform display.

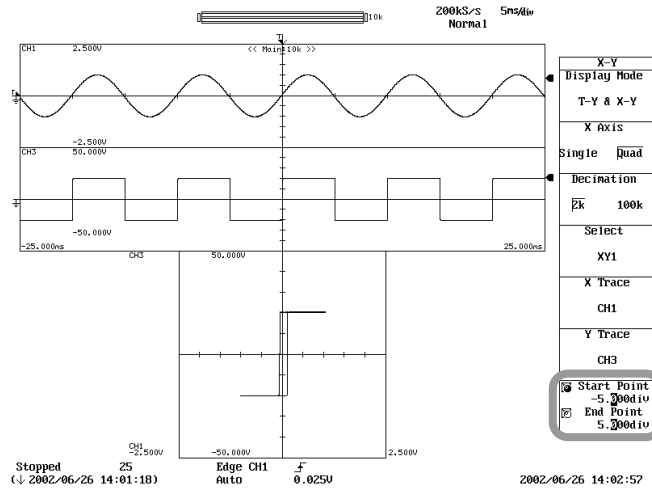

**Explanation**

**Selecting the X Axis Mode**

- Single: The X axis is set to a common trace, and the Y axis displays all the waveforms whose display are turned ON.
- Quad: The X axis trace and Y axis trace are set individually for XY1 to XY4.

**Assigning X (Horizontal) and Y (Vertical) Axes (When X Axis Is Set to Quad)**

The channels that are assigned to the X and Y axes depending on the X-axis mode are as follows:

X Axis Mode	X-Y Waveform	X Axis	Y Axis
Single		CH1 to CH16, DSP1 to DSP6 Math1 to Math8	All channels that are turned ON
Quad	XY1	CH1 to CH8, DSP1 to DSP3 Math1 to Math4	CH1 to CH8, DSP1 to DSP3 Math1 to Math4
	XY2	CH1 to CH8, DSP1 to DSP3 Math1 to Math4	CH9 to CH16, DSP4 to DSP6 Math5 to Math8
	XY3	CH9 to CH16, DSP4 to DSP6 Math5 to Math8	CH1 to CH8, DSP1 to DSP3 Math1 to Math4
	XY4	CH9 to CH16, DSP4 to DSP6 Math1 to Math4	CH9 to CH16, DSP4 to DSP6 Math5 to Math8

**Number of X-Y Waveforms That Can Be Displayed**

The number of X-Y waveforms that can be displayed is 16 for Single and 4 for Quad. The display of each X-Y waveform is turned ON/OFF by turning the Y axis trace display ON/OFF.

**Selecting the Display Mode**

You can select from the following three display modes.

- T-Y&X-Y: The top window displays T-Y (normal) waveforms. The bottom window displays X-Y waveforms.
- X-Y: Displays only X-Y waveforms.
- T-Y: Displays only T-Y waveforms.

### **Setting the Number of Data Points to Be Used for Waveform Display: Decimation**

Same as “Setting the Number of Data Points to Be Used for Waveform Display” described in section 11.6.

For details, see section 11.6.

### **Selecting the Display Range of X-Y Waveforms: Start Point/End Point**

The X-Y display shows the range selected on the T-Y waveform.

You can set the start (fine dashed line) and end (coarse dashed line) positions in the range -5 to +5 divisions from the center of the waveform display frame. The start and end positions are not displayed if only X-Y waveforms are displayed.

The resolution is as follows:

Resolution:  $T/\text{div} \times 10 \div \text{display record length}$

### **Notes When Displaying X-Y Waveforms**

- The divided windows of the T-Y waveform display when using the T-Y & X-Y mode are displayed according to Format in the DISPLAY menu.
- The zoom function applies only to T-Y waveforms. In addition, Main, Z1, or Z2 can be selected for the T-Y waveform display.
- To expand the X-Y waveform, change Upper and Lower settings or V Zoom setting of each channel. The displayed waveform can be enlarged/reduced in a similar fashion.
- To change the display position of the X-Y waveform, change the position of each channel (for voltage input).
- X-Y waveform is not displayed when the horizontal axis of a waveform trace is in units of time and the horizontal axis of another waveform trace is in units of frequency.
- Logic waveforms and event waveforms are not applicable to X-Y waveform display.
- When using the dual capture function, X-Y display and T-Y&X-Y display are not possible.

## 8.7 Using the Snapshot Function and Clear Trace Function

<For a description of this function, refer to page 2-41.>

### Procedure

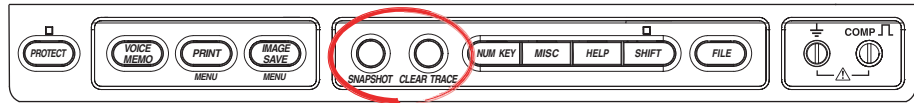

### Snapshot

Press **SNAPSHOT** to take a snapshot of the screen.

### Clear Trace

Press **CLEAR TRACE** to clear the waveform.

### Explanation

#### Snapshot

The snapshot function leaves the current displayed waveform on the screen. This function allows the current displayed waveform to remain temporarily on the screen (snapshot waveform) without requiring waveform acquisition to stop. It is useful when you wish to compare waveforms.

You cannot perform the following operations on snapshot waveforms.

- Cursor measurements and automated measurement of waveform parameters
- Zoom and computation
- Position movement
- X-Y waveform display

You can save and load snapshot waveforms.

For details, see section 13.9, "Saving and Loading Waveforms Captured Using Snapshot."

#### Clear Trace

Clears all the waveforms that are currently displayed on the screen.

Loaded waveforms are also cleared.

When you restart waveform acquisition, the waveforms in the acquisition memory are cleared.

#### Note

The data corresponding to the waveforms that have been cleared by executing clear trace remains in the history memory. You can display the waveform again by selecting the desired waveform record using Select Record on the History menu.

#### Conditions When SNAPSHOT and CLEAR TRACE Cannot Be Used

- Remote mode using the communication interface
- When printing
- During auto setup
- When Mode is set to Zone in the GO/NO-GO menu

# 8.8 Turning Translucent Mode ON/OFF

<For a description of this function, refer to page 2-38.>

## Procedure

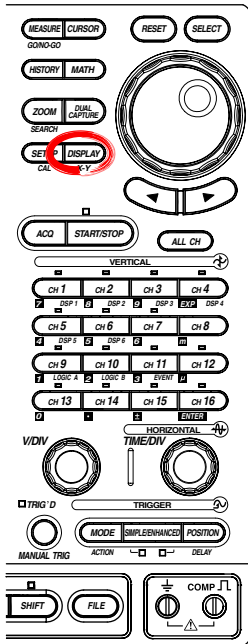

1. Press **DISPLAY**.
2. Press the **Next 1/2** soft key.
3. Press the **Translucent** soft key to select ON or OFF.

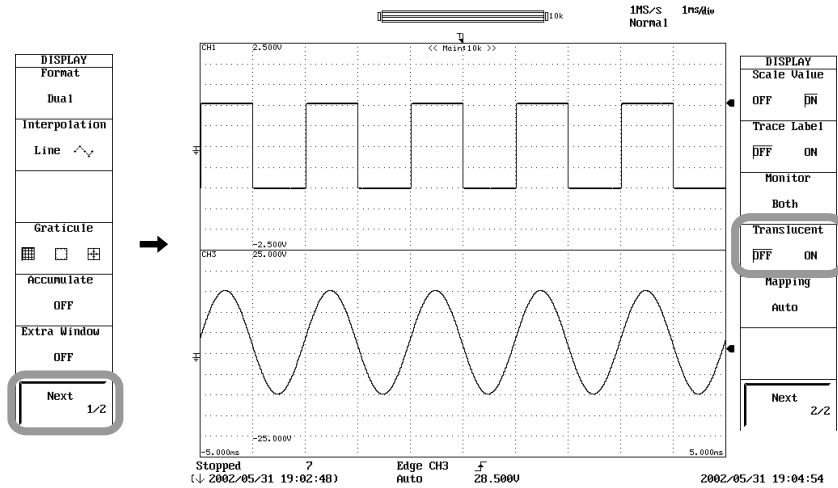

## Explanation

When this is turned to ON, the popup menu becomes translucent. The contents underneath the popup menu can be seen.

Translucent: OFF

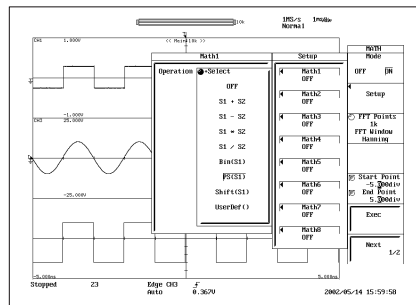

Translucent: ON

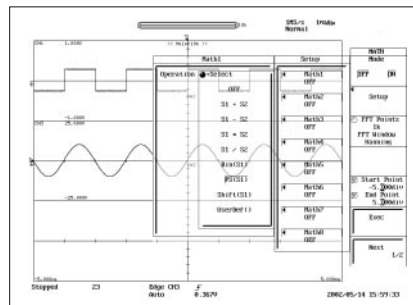



# 8.9 Turning the Scale Value Display ON/OFF

<For a description of this function, refer to page 2-38.>

## Procedure

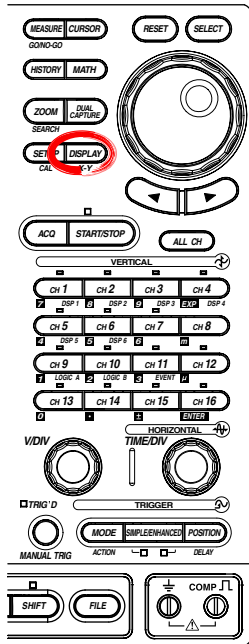

1. Press **DISPLAY**.
2. Press the **Next 1/2** soft key.
3. Press the **Scale Value** soft key to select ON or OFF.

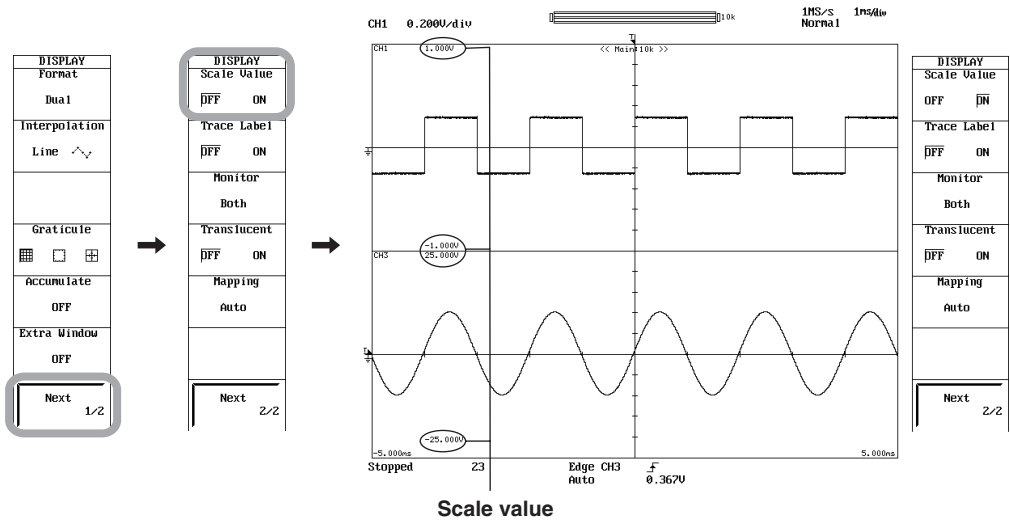

## Explanation

You can turn ON/OFF the upper and lower limits of the vertical and horizontal axes of each channel and the scale value display corresponding to the upper and lower limits.

### Note

The scale values are displayed to the left of the waveform display area. If the scale values do not fit in the section left of the waveform display area, they are displayed on the right side of the waveform display area.

## 8.10 Setting Waveform Labels

<For a description of this function, refer to page 2-38.>

### Procedure

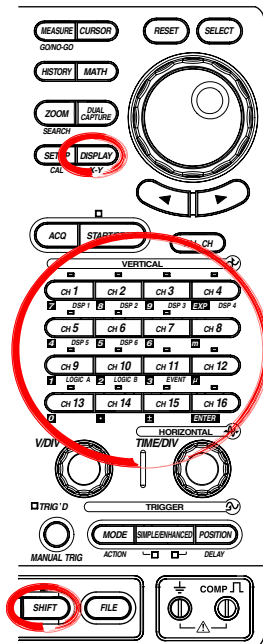

#### Setting the Waveform Label

1. Press **CH1 to CH16**, **SHIFT+CH9 (LOGIC A)**, **SHIFT+CH10 (LOGIC B)**, or **SHIFT+CH11 (EVENT)** to select the desired channel. If you select a channel between CH1 and CH16, proceed to step 2; If you select LOGIC A, LOGIC B, or EVENT, proceed to step 3.
2. Press the **Next 1/2** soft key.
3. Press the **Label** soft key to display a keyboard, and enter the waveform label according to the procedure given in section 4.2.

#### Turning ON/OFF the Waveform Labels

4. Press **DISPLAY**.
5. Press the **Next 1/2** soft key.
6. Press the **Trace Label** soft key to select ON or OFF.

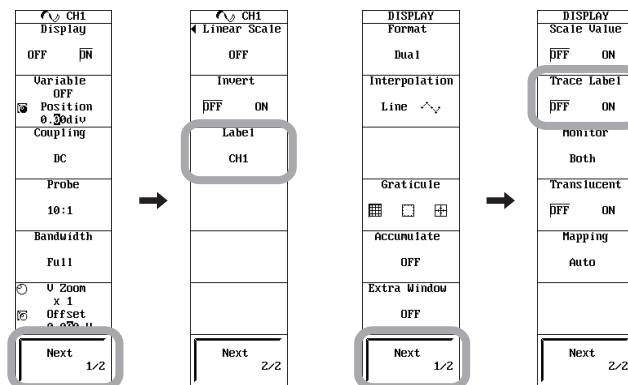

### Explanation

#### Setting the Waveform Label

You can arbitrary set the waveform label of each channel using up to eight characters. The labels are applied to waveform labels, scale values, numeric display, and cursor measurement values. (However, for cursor measurement, only the first 5 characters are displayed.)

#### Turning ON/OFF the Waveform Labels

You can select whether to display labels corresponding to the displayed waveforms.

#### Note

If the waveform display area is small due to the display format setting or zoom format, waveform labels may not be displayed.

# 8.11 Turning the Extra Window ON/OFF

<For a description of this function, refer to page 2-38.>

## Procedure

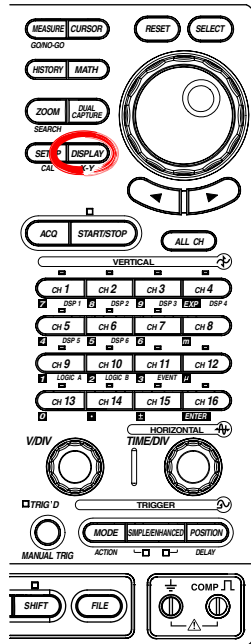

1. Press **DISPLAY**.
2. Press the **Extra Window** soft key. The extra window selection menu appears.
3. Press the ON or OFF soft key.
4. If you select ON, use the **jog shuttle** to set the height of the extra window in the range of 0 to 8.

### Extra Window: OFF

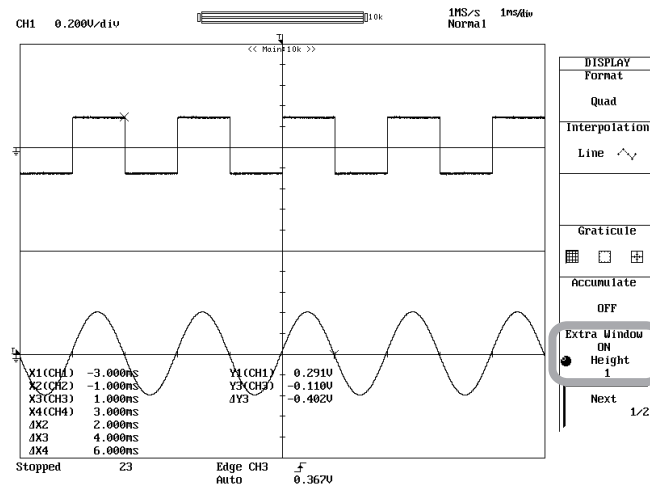

### Extra Window: ON

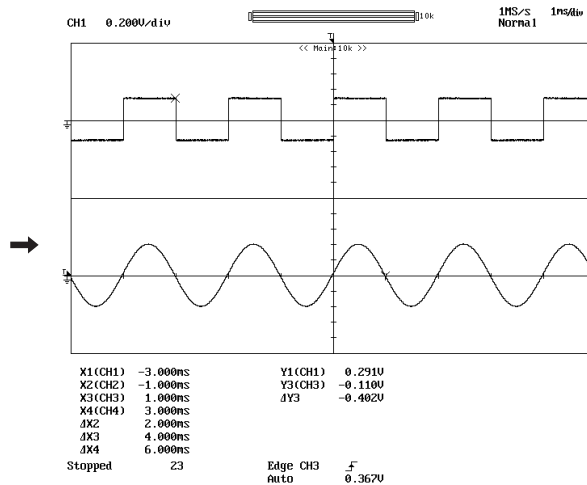

**Explanation**

An extra window is provided to display information other than waveforms when waveforms obscure the information in the display area. The following three types of information can be displayed in the extra window.

- Cursor measurement values
- Automated measured value of waveform parameters
- Numeric display of each channel (only during roll mode display)

**• Example of Cursor Measurement Values**

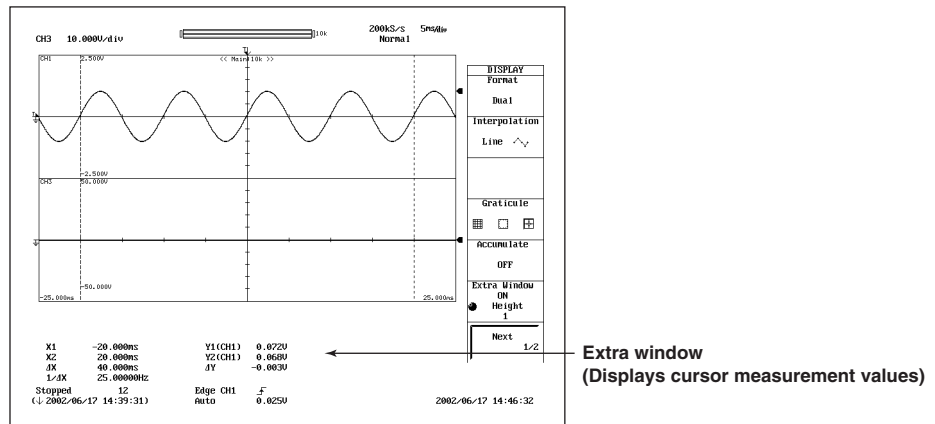

**Number of Points Displayed Vertically When Extra Window Is ON**

When the extra window is turned ON, the vertical axis size of the waveform display window is reduced according to the Height setting. The vertical resolution does not change, but the number of displayed points varies as follows:

Height setting = 8:	384	Height setting = 7:	400
Height setting = 6:	416	Height setting = 5:	432
Height setting = 4:	448	Height setting = 3:	464
Height setting = 2:	480	Height setting = 1:	496
Height setting = 0:	518		

(When the display format is set to Single)

**Note**

Use of the extra window together with certain zoom formats may cause scale values to overlap making them difficult to be read.

# 8.12 Turning the Level Indicator and Numeric Value Display ON/OFF

<For a description of this function, refer to page 2-38.>

## Procedure

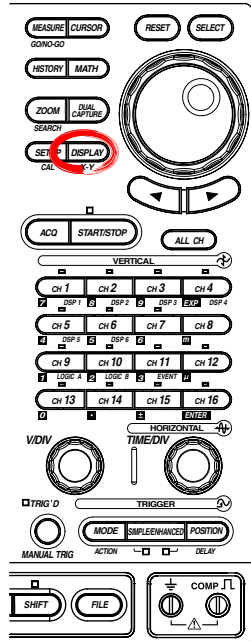

1. Press **DISPLAY**.
2. Press the **Next 1/2** soft key.
3. Press the **Monitor** soft key. The monitor selection menu appears.
4. Press the **Level Indicator** soft key to display the level indicator, the **Numeric Value** soft key to display numeric values, the **Both** soft key to display both, or the **OFF** soft key to display neither.

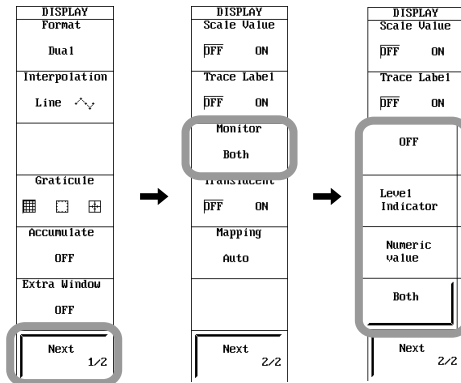

## Explanation

### Level Indicator and Numeric Values: Monitor

**Level indicator:** The level of each waveform is displayed using an indicator to the right of the waveform display window.

**Numeric value:** Displays the measured value of each channel when in roll mode.

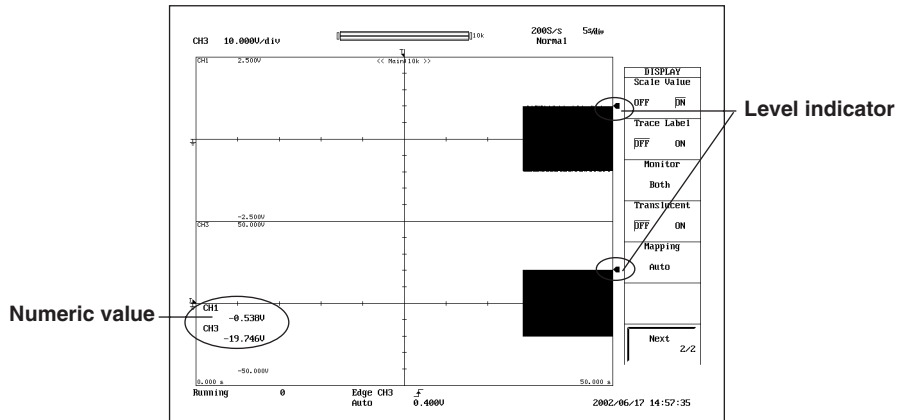

### Note

- The numerical values are displayed when the time base is set to internal clock and the T/div setting is set slower than 100 ms/div.
- The numerical values are not displayed during the GO/NO-GO determination.

# 8.13 Displaying Channel Information/Displaying Waveforms on a Full Screen (Expanding the Waveform Area)

<For a description of this function, refer to page 2-39.>

## Procedure



### Displaying the Channel Information

1. Press **ESC** while the setup menu is displayed. The setup menu displayed on the right side of the screen disappears, and the key information about the channels (CH1 to CH16, DSP1 to DSP6 (option)) whose display is turned ON is displayed.

### Displaying the Numeric Monitor

2. Press **ESC** on the screen showing the channel information. The channel information disappears, and the numeric monitor of the channels (CH1 to CH16, LogicA, LogicB, DSP1 to DSP6 (option)) whose display is turned ON is displayed.

### Expanding the Waveform Display Area

3. Press **ESC** on the screen showing the numeric monitor. The numeric monitor disappears and the waveform display area is expanded horizontally. If you press **ESC** again, the channel information is displayed.

### Displaying the Parameter That Was Controlled by the Jog Shuttle Immediately Before Pressing the ESC Key

4. Press **SELECT** in step 1, 2, or 3. The parameter that was controlled by the jog shuttle immediately before pressing ESC is displayed. To change the setting, operate the jog shuttle in the usual manner.
5. Press **ESC**. The parameter display disappears.

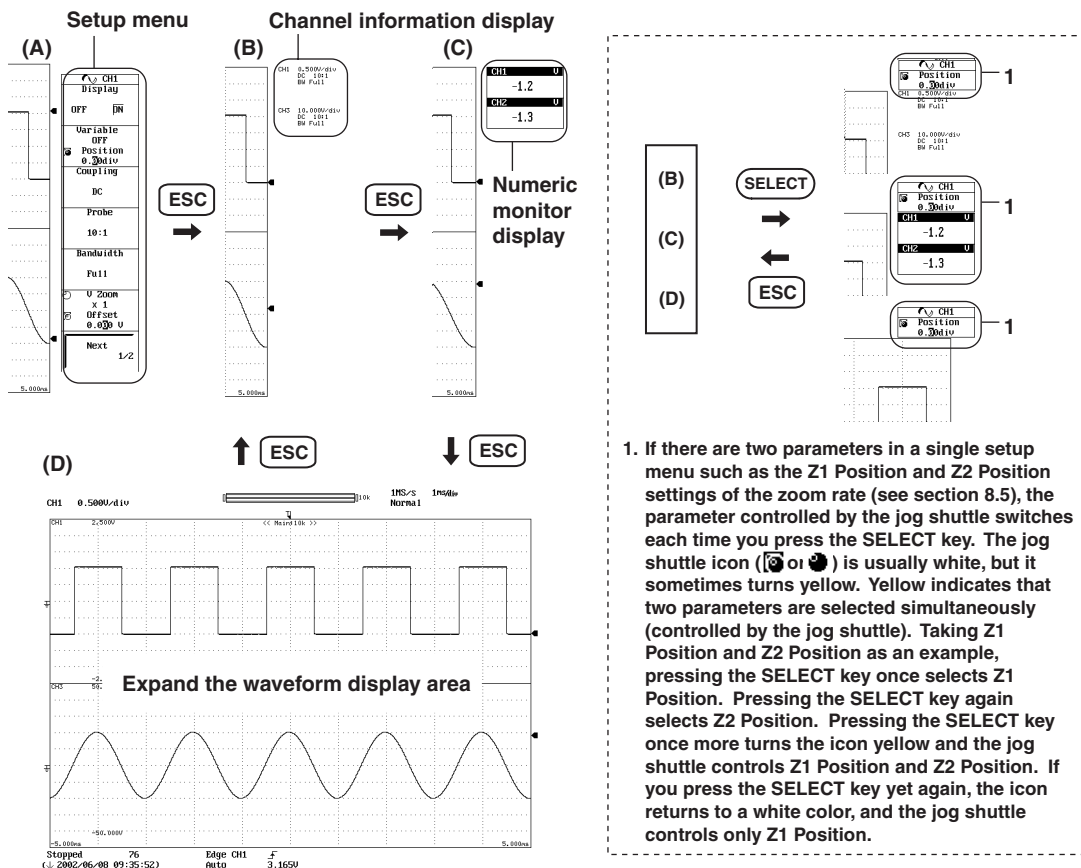

1. If there are two parameters in a single setup menu such as the Z1 Position and Z2 Position settings of the zoom rate (see section 8.5), the parameter controlled by the jog shuttle switches each time you press the SELECT key. The jog shuttle icon (⊖ or ⊕) is usually white, but it sometimes turns yellow. Yellow indicates that two parameters are selected simultaneously (controlled by the jog shuttle). Taking Z1 Position and Z2 Position as an example, pressing the SELECT key once selects Z1 Position. Pressing the SELECT key again selects Z2 Position. Pressing the SELECT key once more turns the icon yellow and the jog shuttle controls Z1 Position and Z2 Position. If you press the SELECT key yet again, the icon returns to a white color, and the jog shuttle controls only Z1 Position.

## 8.13 Displaying Channel Information/Displaying Waveforms on a Full Screen (Expanding the Waveform Area)

### Note

- Each time you press the ESC key, the display switches cyclically as follows: channel information display → numeric monitor display → full screen display of waveforms full → channel information display.
- When the DL750/DL750P receives communication commands, the screen switches to channel information display.

### Explanation

#### Displaying the Channel Information

Pressing the ESC key once when the setup menu is displayed shows the channel information. The parameters displayed in the channel information are as follows. However, not all parameters may be displayed when the number of display channels increases.

- When measuring voltage: V/div setting, input coupling, probe attenuation (type), and bandwidth limit.
  - When measuring temperature: Temperature/div setting, thermocouple type, and bandwidth limit.
  - When measuring strain:  $\mu$ STR/div (or [mV/V]/div) setting, measurement range, and bandwidth limit.
  - When measuring acceleration\*: Acceleration/div setting, gain, input coupling, and bias setting.
  - When measuring the frequency\*: Value/div setting, measurement mode setting, and preset setting.
  - For DSP channels: Value/div setting and computing equation.
- \* Some items may not be displayed depending on the amount of information present.

#### Displaying the Numeric Monitor

Pressing ESC key once when the channel information is displayed clears the channel information and shows the numeric monitor of the channels (CH1 to CH16, LogicA, LogicB, DSP1 to DSP6 (option)) whose display is turned ON is displayed.

The display update interval of numeric monitor is 1 s.

### Note

#### Notation of the Numeric Monitor of Logic Waveforms

The numeric monitor of logic waveforms (Logic A or Logic B) is displayed in binary or hexadecimal notation.

Select the notation by carrying out the following procedure.

Press the CURSOR key > Type soft key > Vertical soft key, press the Logic Setup soft key that appears when Trace is set to All, LogicA, LogicB, or LogicA & LogicB, and set Format to Binary or Hexa. For details, see step 1 to 7 on page 11-18 and "Display Format of Logic Waveforms" on page 11-28.

#### • Binary

LogicA
00000000
LogicB
00000000

#### • Hexadecimal

LogicA <HEXA>
00
LogicB <HEXA>
00

#### Expanding the Waveform Display Area

Pressing the ESC key once when the channel information is displayed clears the channel information and expands the waveform display area horizontally to cover the entire screen. The waveform display area is expanded at power up.

#### Displaying the Parameter That Was Controlled by the Jog Shuttle Immediately Before Pressing the ESC Key

The parameter that was controlled by the jog shuttle immediately before can be displayed by pressing the SELECT key when the channel information is displayed or when the waveform display area is expanded. The setting of this parameter can be changed by operating the jog shuttle in the usual manner. To clear the display of the parameter, press the ESC key.

## 9.1 Loading the Roll Paper into the DL750P Built-in Printer

This section describes how to load the DL750P roll paper. For the procedure to load the DL750 roll paper, see section 12.1.

### Printer Roll Paper

Use a dedicated roll paper (for the DL750P) that is provided by YOKOGAWA. Do not use other types of roll paper. When you are using the printer for the first time, use the roll paper that comes with the package. Order extra rolls from your nearest YOKOGAWA dealer.

Part No.: 701966  
Specifications: Thermal paper, 20 m  
Minimum Q'ty: 6 rolls

### Roll Paper Handling

The paper is a Thermal paper that changes color with the application of heat. Note the following:

#### Storage Precautions

The paper starts changing color at around 70° C. It is affected by heat, humidity, light, and chemicals regardless of whether the paper has been used.

- Store the paper rolls in a cool, dry, and dark place.
- After opening the package, use it quickly.
- If the paper is left in contact with plastic film containing plasticizers (such as a vinyl chloride film or Scotch tape) for an extended time, the paper will lose some of its ability to reproduce color. If you are going to store the paper in a folder, for example, use a folder made of paper stock or polypropylene.
- When using glue on the paper, do not use glue containing organic solvents such as alcohol or ether, as they will change the color of the paper.
- For prolonged storage, we suggest you make copies of results printed on the roll paper. Due to the characteristics of the Thermal paper, the recording section may lose color over time.

#### Handling Precautions

- Be sure to use only genuine paper rolls provided by YOKOGAWA.
- Touching the paper with sweaty hands can leave finger prints or blur the printing.
- Rubbing the surface with a hard object can cause the paper to change color due to the heat caused by friction.
- If chemicals, oil, or other liquids come in contact with the paper, the paper may change color or the printing may fade.

### Precautions to Be Taken When Using the Built-in Printer

Allow enough space around the output area of the printer. If the roll paper is continuously fed out when the output area is close to a wall, for example, the roll paper that has been delivered may reenter the output area and get entangled.



**Procedure**

**Loading the Roll Paper**

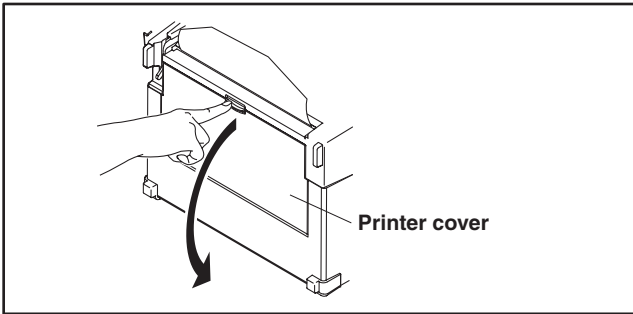

1. While pressing the knob down on the top side of the printer cover, open the printer cover.

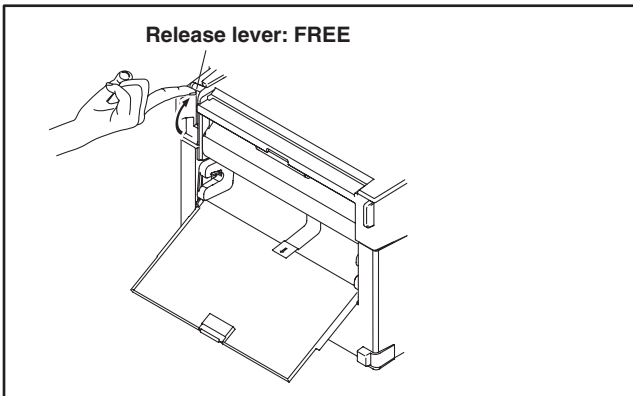

2. Move the release lever at the top left side to the FREE position (up direction).

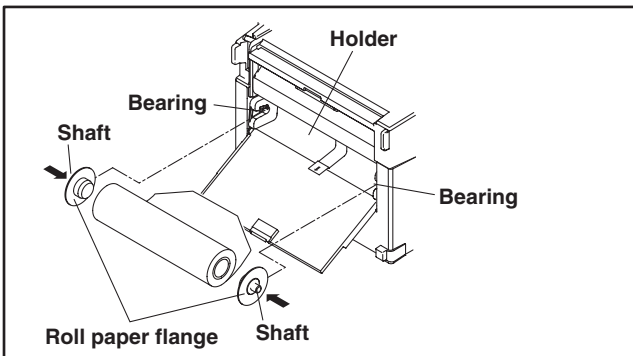

3. Fit the roll paper flange to the left and right edges of the roll paper core.
4. With the leading edge of the roll paper in the back, load the roll paper in the holder by pressing the shaft of the roll paper flange in the holder bearing. Set the direction of the roll paper as shown in the left figure. If the direction is reversed, the printer head does not make contact with the thermal-sensitive surface. If this happens, nothing may be printed, or the paper may not feed properly.

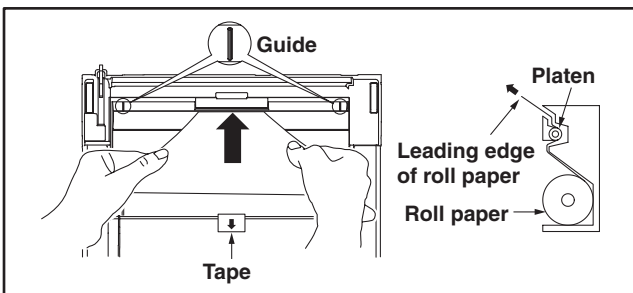

5. Insert the leading edge of the roll paper evenly from the bottom side of the platen, and pass it through so that approximately 2 cm is showing from the top side. Align the roll paper with the left and right guides. To remove a roll paper that is already loaded, pull the tape in the direction of the arrow.

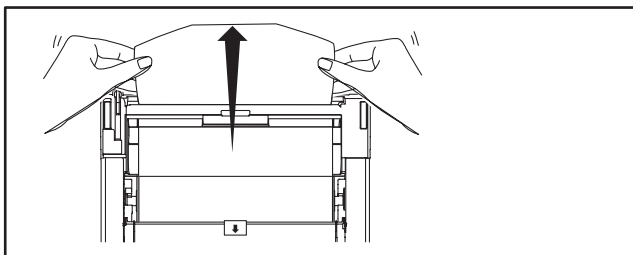

6. Pull the roll paper out further to straighten out the paper.

## 9.1 Loading the Roll Paper into the DL750P Built-in Printer

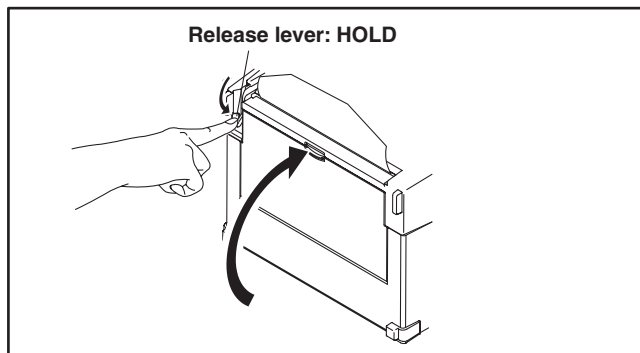

7. Move the release lever to the HOLD position (down direction). The printing will fail with an error message, if the release arm is in the FREE position during operation.
8. Close the printer cover. Push the printer cover down firmly until it clicks into place.

### Note

- If you are reusing an old roll paper that had been taken out, the roll paper can be inserted easily by cutting the leading edge at an angle.
- Before closing the printer cover, be sure to set the release arm position to HOLD.
- After loading the roll paper, make sure that the paper is feeding properly according to the steps given below. If the paper is not being fed evenly, continue to feed the paper for approximately 30 cm. The paper will straighten out.

## Feeding the Paper

You can feed the paper to check whether the roll paper has been loaded properly or to skip dirty sections.

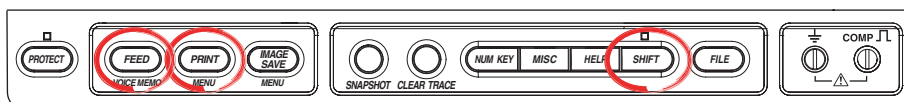

### Feeding Paper with the FEED Key

1. Press the **FEED** key. Each time the key is pressed, the paper is fed out by 15 mm.

### Feeding Paper from the PRINT Menu

1. Press **SHIFT+PRINT**.
2. Press the **Print to** soft key. The printer selection menu appears. (Net Print appears only when the Ethernet interface option is installed.)
3. Press the **Printer** soft key.
4. Press the **Paper Feed** soft key. Each time the key is pressed, the paper is fed out by 15 mm.

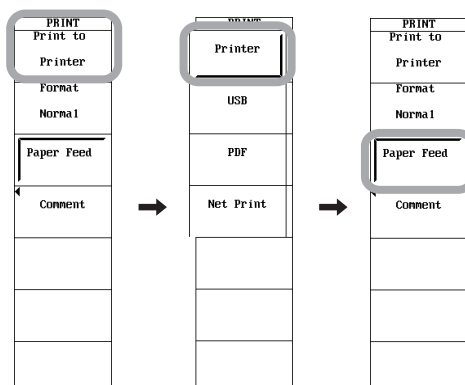

## 9.2 Selecting the Recorder Mode

<For a description of this function, refer to page 2-43.>

### Procedure

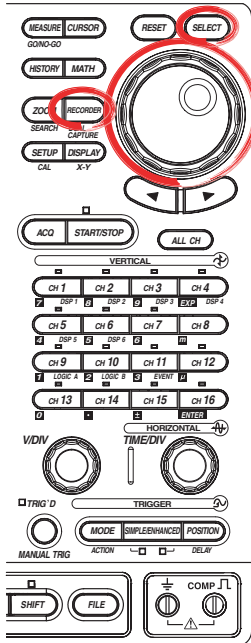

When the recorder mode is changed by following the procedure in this section, the measured data is cleared. Be sure to save data that you need before changing the recorder mode. For the procedure of saving the data, see chapter 13 in the User's Manual Part 2.

1. Press **RECORD**.
2. Press the **Mode** soft key to display the recorder mode selection menu.
3. Press the **Chart Recorder** or **X-Y Recorder** soft key.  
If the recorder mode is changed to a mode different from the mode up to then or if a recorder mode is selected from the OFF setting, an alert dialog box appears.
4. If an alert dialog box appears, use the **jog shuttle** and **SELECT** to select OK.  
If Chart Recorder is selected, proceed to step 5.
5. Press the **Print Style** soft key to select Wave (recorder T-Y waveforms) or Numeric (record numeric values).

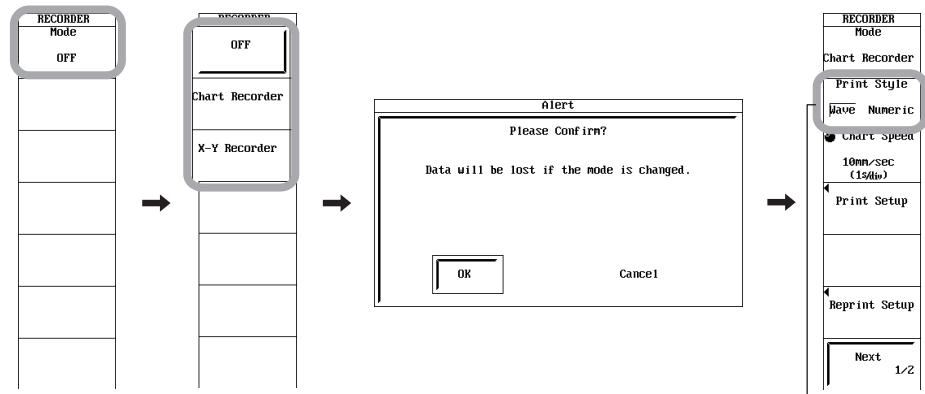

Only when Chart Recorder is selected

Then, configure the respective recorder mode.

### When Chart Recorder Is Selected

#### **When Wave (Record T-Y Waveforms) Is Selected**

Continue with the procedures described in sections 9.3 to 9.5.

#### **When Numeric (Record Numeric Values) Is Selected**

Continue with the procedures described in section 9.6.

### When X-Y Recorder Is Selected

Continue with the procedures described in section 9.7.

**Explanation****Selecting the Recorder Mode**

When recording in recorder mode, first select the recorder mode. There are two recorder modes, Chart Recorder and X-Y Recorder. If Chart Recorder mode is selected, select the print style, Wave (record T-Y waveforms) or Numeric (record numeric values).

**Functions That Cannot Be Used during Chart Recorder Mode or X-Y Recorder Mode**

The following functions (keys) cannot be used during recorder mode.

- History memory (HISTORY)
- GO/NO-GO determination (GO/NO-GO)
- Dual capture
- Waveform computation (MATH)

Also, items that are set with the ACQ or X-Y key cannot be changed.

Search & zoom (SHIFT+ZOOM (SEARCH)) cannot be used in X-Y Recorder mode.

**DL750P Settings in Chart Recorder Mode**

If Chart Recorder mode is selected, the DL750P settings change as follows:

Menu	Soft Key	Setting
ACQ	Record Length Mode Time Base RealTime Out	Fixed to 2.5 MW Envelope* <sup>1</sup> Int OFF
TIME/DIV		Linked to the chart speed* <sup>2</sup>
X-Y	Mode	T-Y Only
GO/NO-GO	Mode	OFF
MATH	Mode	OFF
DUAL CAPTURE	Mode	OFF
MEASURE	Mode	Statistics and History Statistics set to OFF
DISPLAY	Accumulate	OFF

\*1 The acquisition mode can be changed from Envelope to Normal using MISC menu > Others soft key. For details, see section 9.3.

\*2 For the procedure of setting the chart speed, see section 9.3.

If the recorder mode is switched from OFF to Chart Recorder mode back to OFF, the ACQ menu items and TIME/DIV setting return to the settings that existed before switching to Chart Recorder mode.

**DL750P Settings during X-Y Recorder Mode**

If X-Y Recorder mode is selected, the DL750P settings change as follows:

Menu	Soft Key	Setting
ACQ	Record Length	Fixed to 1 MW
(TRIGGER)MODE		Auto

If the recorder mode is switched from OFF to X-Y Recorder mode back to OFF, the ACQ menu items and (TRIGGER) MODE setting return to the settings that existed before switching to X-Y Recorder mode.

## 9.3 Setting the Record Conditions of T-Y Waveform Recording

<For a description of this function, refer to page 2-43.>

### Procedure

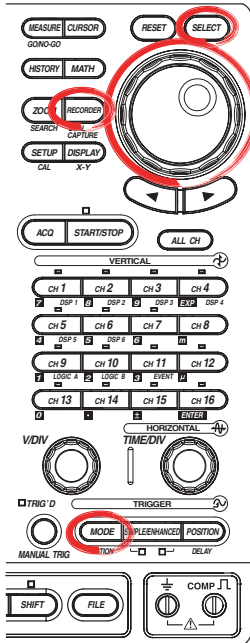

Before carrying out the procedure below, set the recorder mode and print style as follows according to the procedures in section 9.2.

- Recorder mode: Chart Recorder
- Print style: Wave (T-Y waveform recording)

#### Setting the Chart Speed

1. Press the **Chart Speed** soft key.
2. Use the **jog shuttle** to set the chart speed in the range of 10 mm/h to 20 mm/s.

#### Note

The chart speed can also be set using the TIME/DIV knob.

#### Setting the Shot Recording

3. Press the **Next 1/2** soft key
4. Press the **Shot Recording** soft key to display a menu used to select the length of the short recording.
5. Press the soft key corresponding to the desired length of the short recording. Select OFF (no shot recording), 20 cm, 50 cm, 1 m, or 2m.

#### Enabling/Disabling T-Y Recording to the Built-in Printer

6. Press the **Printer Output** soft key to select ON or OFF.

#### Setting the Trigger Mode

7. Press **MODE**.
8. Press the soft key corresponding to the desired mode to set the trigger mode to Auto, Repeat, Single, or Log.

#### Setting the Acquisition Mode

Normally, the acquisition mode in Chart Recorder mode is envelope. If you wish to switch to normal mode, carry out steps 9 to 12 below.

9. Press **MISC**.
10. Press the **Next 1/2** soft key.
11. Press the **Others** soft key.
12. Press the **Chart Recorder Sample** soft key to select Envelope or Normal.

#### Set the chart speed and enable/disable shot recording and T-Y recording

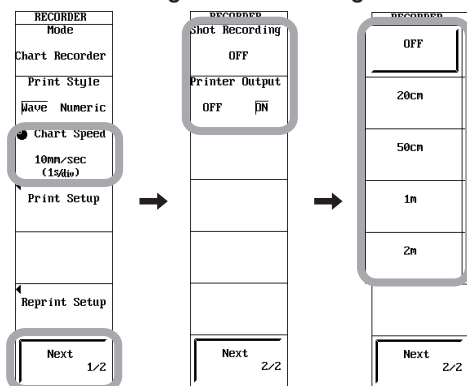

#### Set the trigger mode

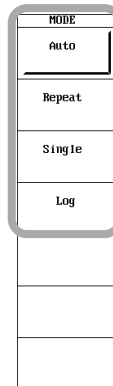

#### Set the acquisition mode

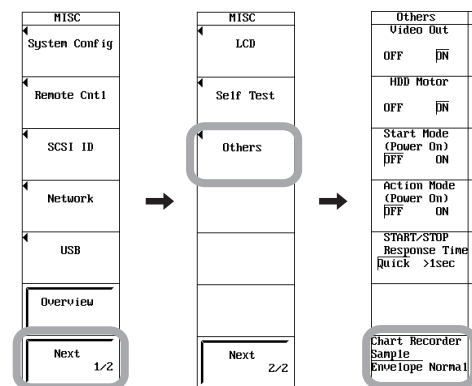

**Explanation****Chart Speed**

For T-Y Recording, the chart speed can be selected from below.

10 mm/h, 20 mm/h, 25 mm/h, 50 mm/h, 100 mm/h, 1 mm/min, 2 mm/min, 5 mm/min, 10 mm/min, 20 mm/min, 25 mm/min, 50 mm/min, 100 mm/min, 1 mm/s, 2 mm/s, 5 mm/s, 10 mm/s, and 20 mm/s

You can set the chart speed using the following two methods.

- Menu that appears by selecting RECORDER menu > Chart Speed soft key
- TIME/DIV knob

The top section of the Chart Speed soft key shows the chart speed. The bottom section shows the horizontal scale (time per division) for T-Y waveform recording.

The chart speed can be changed even while recording is in progress. However, the data saved in the internal memory is cleared.

**Shot Recording**

When the specified length of data is recorded, the measurement and recording stop.

The length of the shot recording can be selected from OFF (no shot recording), 20 cm, 50 cm, 1 m, or 2 m.

**T-Y Recording to the Built-in Printer: Printer Output**

Set whether to carry out T-Y recording to the built-in printer. If set to ON, data is recorded on the built-in printer and saved to the internal memory. If set to OFF, data is saved only to the internal memory. The data is not recorded on the built-in printer.

**Trigger Mode**

In Chart Recorder mode, you can select the trigger mode from Auto, Log, Single, or Repeat.

**Auto**

Starts recording to the built-in printer simultaneously with the start of the measurement. Recording continues until the measurement is stopped.

**Log**

Starts recording to the built-in printer simultaneously with the start of the measurement. Measurement and recording stops when the maximum number of divisions (see page 2-45) of measured values that can be saved is recorded.

**Single**

Starts recording when the trigger conditions are met after the start of the measurement. Measurement and recording stops when the maximum number of divisions (see page 2-45) of measured values that can be saved is recorded.

**Repeat**

Starts recording when the trigger conditions are met after the start of the measurement. Recording stops when the shot record length of measured values is recorded. Then, the DL750P enters the trigger-wait state. The starting/stopping of the recording is repeated until the measurement is stopped.

For details on the trigger mode in Chart Recorder mode, see page 2-43.

**Acquisition Mode**

The acquisition mode in Chart Recorder mode is envelope. However, the mode can be changed to normal mode by using the MISC menu > Others menu.

Envelope and normal modes in Chart Recorder mode are the same as those when recorder mode is disabled. For details, see page 2-31.

# 9.4 Setting the Recording Format of T-Y Waveform Recording

<For a description of this function, refer to page 2-43.>

## Procedure

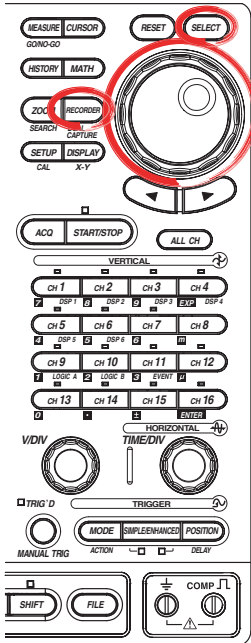

Before carrying out the procedure below, set the recording conditions of T-Y waveform recording according to the procedures in sections 9.2 and 9.3.

1. Press the **Print Setup** soft key to display the print setup dialog box.

### Setting the Display (Recording) Format

2. Use the **jog shuttle** and **SELECT** to select Format from Single (1 division) to Hexadecimal (16 divisions).

#### Note

The display (recording) format setting is linked with the DISPLAY menu > Format setting.

### Setting the Extra Area

3. Use the **jog shuttle** and **SELECT** to set **Extra Area** to ON or OFF.

### Setting the Flexible Zone

4. Use the **jog shuttle** and **SELECT** to select **Setup** in **Flexible Zone**.
5. Use the **jog shuttle** and **SELECT** to set Mode to OFF or ON.
6. Use the **jog shuttle** and **SELECT** to set Upper/Lower of the waveform to be recorded.

### Setting the Graticule

#### Setting the Graticule

7. Use the **jog shuttle** and **SELECT** to set Type to , OFF, or .

#### Setting Dark/Light

8. Use the **jog shuttle** and **SELECT** to set Dark/Light to Light or Dark.

#### Setting the Width of the Vertical Scale

9. Use the **jog shuttle** and **SELECT** to set Width to 1div or 10mm.

#### Note

The graticule setting is linked with the DISPLAY menu > Graticule setting. However, if OFF is selected, the DISPLAY menu is set to .

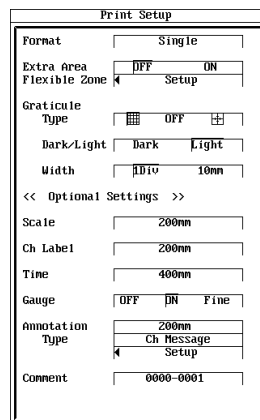

### When Setup of Flexible Zone is selected

Flexible Zone					
Mode	OFF	DN			
No.	Upper	Lower	No.	Upper	Lower
CH1	100%	0%	Math1	100%	0%
CH2	100%	0%	Math2	100%	0%
CH3	100%	0%	Math3	100%	0%
CH4	100%	0%	Math4	100%	0%
CH5	100%	0%	Math5	100%	0%
CH6	100%	0%	Math6	100%	0%
CH7	100%	0%	Math7	100%	0%
CH8	100%	0%	Math8	100%	0%
CH9	100%	0%	DSP1	100%	0%
CH10	100%	0%	DSP2	100%	0%
CH11	100%	0%	DSP3	100%	0%
CH12	100%	0%	DSP4	100%	0%
CH13	100%	0%	DSP5	100%	0%
CH14	100%	0%	DSP6	100%	0%
CH15	100%	0%			
CH16	100%	0%			

**Setting Details**

**Setting the Print Interval of Scale Values**

- 10. Use the **jog shuttle** and **SELECT** to set Scale to OFF, 200mm, 400mm, or 800mm.

**Setting the Print Interval of Channel Labels**

- 11. Use the **jog shuttle** and **SELECT** to set CH Label to OFF, 200mm, 400mm, or 800mm.

**Setting the Print Interval of Time**

- 12. Use the **jog shuttle** and **SELECT** to set Time to OFF, 200mm, 400mm, or 800mm.

**Setting the Gauge Print**

- 13. Use the **jog shuttle** and **SELECT** to set Gauge to OFF, ON, or Fine.

**Setting the Annotation**

- 14. Use the **jog shuttle** and **SELECT** to set the print interval of annotations in the right column of Annotation to OFF, 200mm, 400mm, or 800mm.
- 15. Use the **jog shuttle** and **SELECT** to set the type of annotation to be printed in the right column of Type to CH Information, CH Message, or CH Data. If CH Message is selected, proceed to step 16. If CH Information or CH Data is selected, proceed to step 17.
- 16. Use the **jog shuttle** and **SELECT** to select Setup. Then, enter the message you wish to print for the channel using up to 80 characters according to the procedure in section 4.2.

**Setting a Comment**

- 17. Use the **jog shuttle** and **SELECT** to select Comment. Then, enter the comment text you wish to print using up to 20 characters according to the procedure in section 4.2.

**Note**

The comment setting is linked with the PRINT menu > Comment setting.

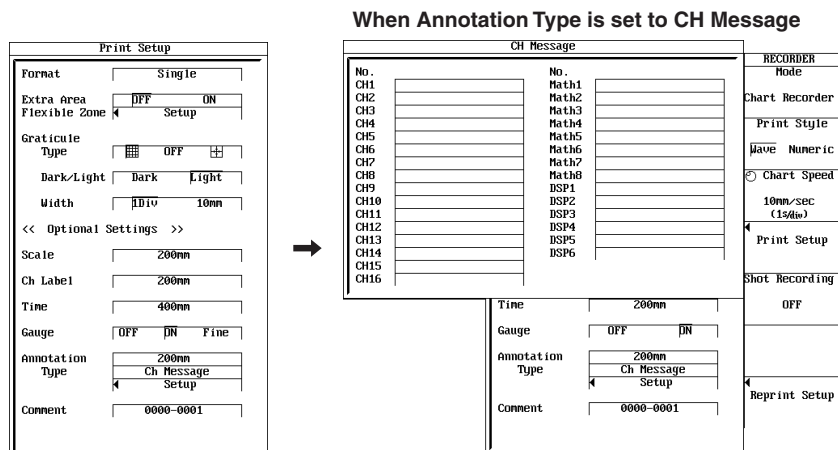

**Explanation**

**Display Format**

Select the number of divisions of the recording area when recording to the built-in printer.  
 Single: 1 division      Triad: 3 divisions      Octal: 8 divisions  
 Dual: 2 divisions      Quad: 4 divisions      Hexadecimal: 16 divisions

The display (recording) format setting is linked with the DISPLAY menu > Format setting.



## 9.4 Setting the Recording Format of T-Y Waveform Recording

### Extra Area

The extra area can be set only when the display (recording) format is set to Single, Dual, Triad, or Quad.

#### When the Format Is Single

If extra area is turned ON, the top 16 cm of the recording area (20 cm) is used to record waveforms, and the remaining 4 cm is used to record waveform information (extra area). Annotations (see the next page) and logic waveforms are recorded in the extra area. The default setting is OFF.

#### When the Format is Dual, Triad, or Quad

If extra area is turned ON, the area below each of the divided waveform recording area is used to record the waveform information (extra area). If extra area is turned OFF, the extra area between each waveform recording area disappears. The vertical axis of each waveform recording area is adjusted automatically according to the paper size and recorded. The default setting is ON.

### Flexible Zone

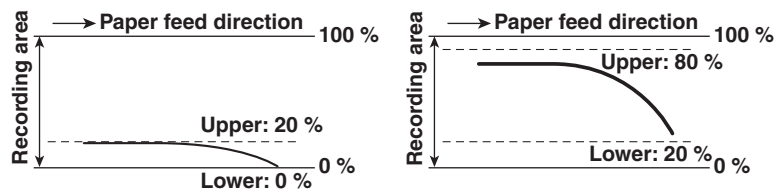

The flexible zone can be set only when the display (recording) format is Single and the extra area is OFF. The position in the recording area (20 cm) where each waveform is to be recorded is set with Upper and Lower (%). The Upper value can be set in the range of 2% to 100%. The Lower value can be set in the range of 0% to 98%. Each value can be set in 1% steps. The minimum width is 2%.

- [Example]
- When Flexible Zone on CH1 is set to Upper = 20% and Lower = 0%  
The CH1 waveform is recorded in the area from the bottom to 4 cm of the recording area.
  - When Flexible Zone on CH2 is set to Upper = 80% and Lower = 20%  
The CH2 waveform is recorded in the area from 4 cm to 16 cm from the bottom of the recording area.



### Graticule

#### Type

Select the graticule type from , OFF, or . The graticule setting is linked with the DISPLAY menu > Graticule setting. However, if OFF is selected, the DISPLAY menu is set to .

#### Dark/Light

Set the graticule Dark/Light setting to Light or Dark.

#### Width of the Vertical Scale: Width





Select how to set the vertical scale width.

1 div: Graticule obtained by dividing the recording area into 10 areas

10mm: mm graticule type

#### Graticule lines that are printed

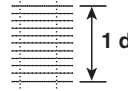
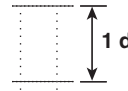
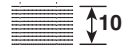
The format of the scale lines that are printed depending on the selected graticule type and width is given in the table below.

Graticule Width	Graticule Type		
		OFF	
1 div	 1 div	No graticule lines	 1 div
10 mm	 10 mm	No graticule lines	 10 mm

**Details****Print Interval of Scale Values**

Select the interval for the scale values printed at the top and bottom edges of the recording area from OFF, 200 mm, 400 mm, or 800 mm. If OFF is selected, the scale values are not printed.

**Print Interval of Channel Labels**

Select the interval for printing waveform channel labels from OFF, 200 mm, 400 mm, or 800 mm. The channel label is printed near each waveform. If OFF is selected, the channel labels are not printed.

**Time Print**

Select the interval for printing the time from OFF, 200 mm, 400 mm, or 800 mm. The time is printed at the top section of the recording area. If OFF is selected, the times are not printed.

**Gauge Print**

Select whether to not print (OFF), print (ON), or print in detail (Fine) on the right (or left) side of the recording area. If ON is selected a gauge that equally divides the waveform display area into two is displayed. If Fine is selected, a gauge that equally divides the waveform display area into 10 is displayed. In realtime recording, the gauge is printed on the right side of the recording area when the recording is completed. When reprinting waveforms saved to the internal memory (see section 9.8), the gauge is printed on the left side of the recording area when the recording is started. The gauge, scale values, an arrow indicating the ground position, and V/div (Value/div)\* are printed.

\* Depending on the setting of T-Y Recording, V/div (Value/div) may not be printed.

**Annotation**

Channel information, channel messages, or measured values are printed. Use Annotation to select the print interval from OFF, 200 mm, 400 mm, and 800 mm. Use Type to select the type of annotation to be printed from CH Information, CH Message, and CH Data.

- **CH Information**

Prints settings such as V/div, filter, and module.

- **CH Message**

Prints the character string (up to 80 characters) that is assigned to each channel.

- **CH Data**

Records the measured values at a given interval using numeric values.

The position where annotations are printed varies depending on the display (recording) format and extra area settings as follows:

- When Format is Single, Dual, Triad, or Quad, and Extra Area is ON  
The annotations are printed in the extra area. Annotations are not printed in the waveform recording area.
- When Format is Single, Dual, Triad, or Quad, and Extra Area is OFF  
The annotations are printed at the bottom section of the waveform recording area.
- When Format is Octal or Hexadecimal  
The annotations are printed between the divided waveform recording areas (between the graticules).

**Note**

If all of the conditions below are met, only up to 67 characters of CH Message are printed.  
Format: Single/Dual/Triad/Quad, Extra Area: OFF, Scale: Other than OFF

**Comment**

A comment string of up to 20 characters can be printed at the bottom right section.

For a print example on the built-in printer of T-Y recording, see the next section.

## 9.5 Recording T-Y Waveforms (T-Y Waveform Recording)

<For a description of this function, refer to page 2-43.>

### Procedure

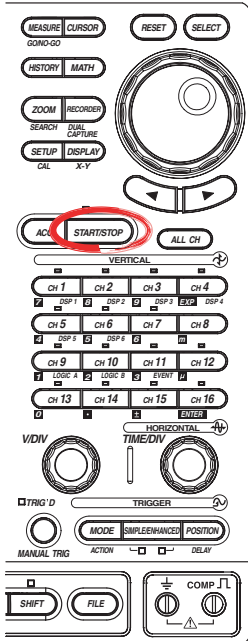

Before carrying out the procedure below, set the recording conditions and recording format of T-Y waveform recording according to the procedures in sections 9.2 to 9.4.

### Starting/Stopping T-Y Waveform Recording

1. Press **START/STOP** to start the waveform acquisition and T-Y waveform recording.
2. To stop T-Y waveform recording, press **START/STOP** again. Waveform acquisition and T-Y waveform recording stop.

### Explanation

#### Starting/Stopping T-Y Waveform Recording

When waveform acquisition is started by pressing the START/STOP key, T-Y waveform recording to the built-in printer also starts. To abort the T-Y waveform recording, press the START/STOP key to stop the waveform acquisition. However, if the T-Y waveform recording to the built-in printer was set to OFF in section 9.4, the data is saved only to the internal memory. T-Y waveform recording to the built-in printer is not performed.

#### Changing the Settings during T-Y Waveform Recording

- The input conditions can be changed even during T-Y waveform recording. (The recording does not stop.)
- Calibration is not executed during T-Y waveform recording.
- The recording format cannot be changed during T-Y waveform recording.
- The chart speed can be changed even during T-Y waveform recording. (The data after the chart speed is changed is saved to the internal memory.)

**Print Example of T-Y Waveform Recording**

Format: Triad  
 Graticule Type:   
 Width: 10 mm

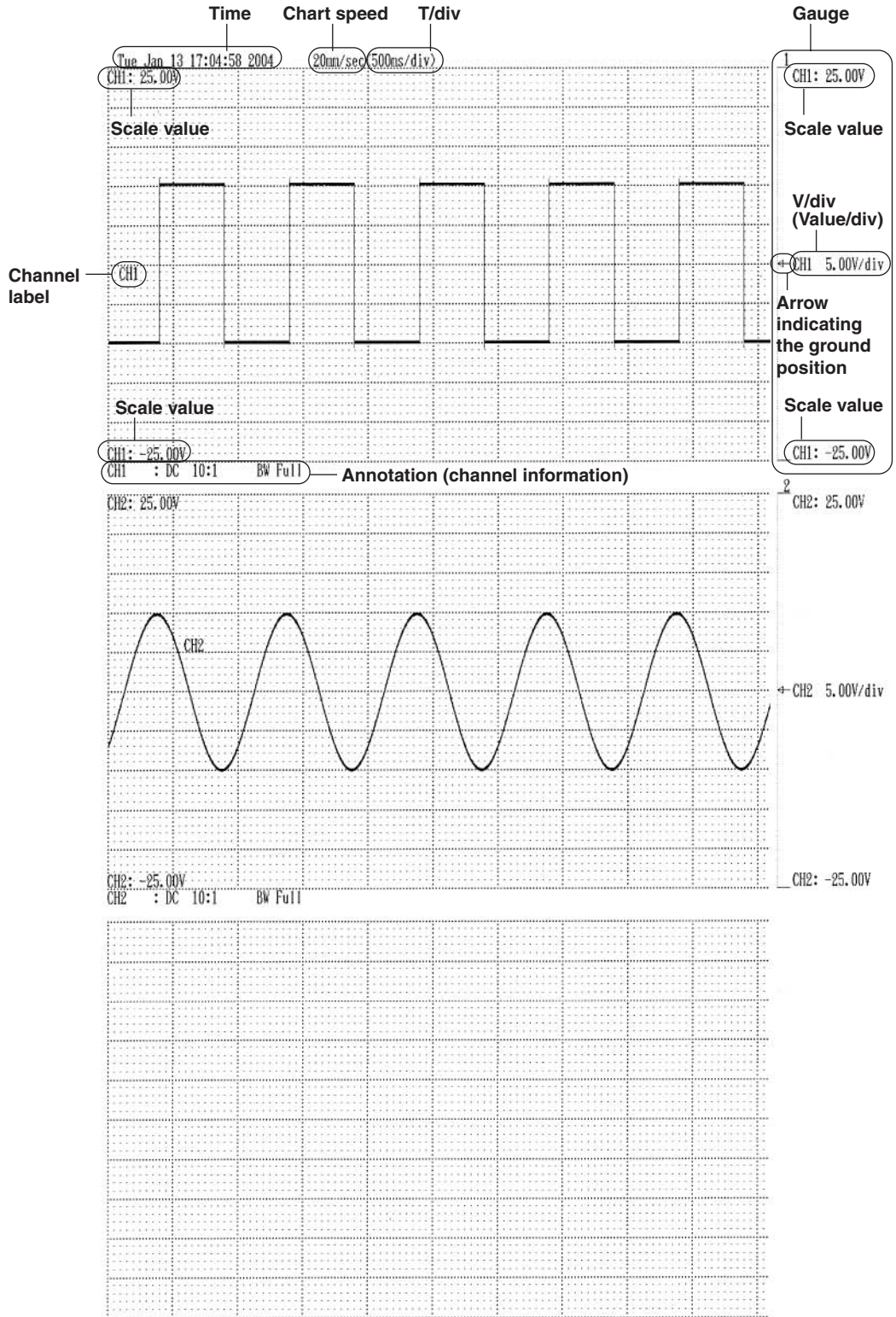

## 9.6 Recording Numeric Values

<For a description of this function, refer to page 2-43.>

### Procedure

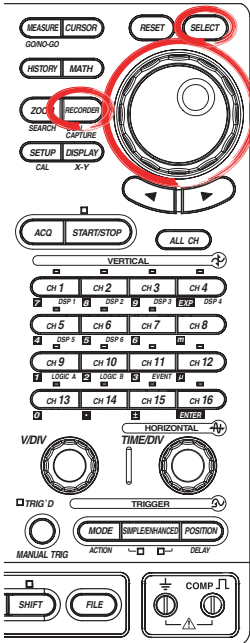

Before carrying out the procedure below, set the recorder mode and print style as follows according to the procedures in section 9.2.

- Recorder mode: Chart Recorder
- Print style: Numeric (numeric value recording)

1. Press the **Print Setup** soft key to display the print setup dialog box.

### Setting the Output Destination

2. Use the **jog shuttle** and **SELECT** to set Output Device to Chart or File.

### Setting the Output Interval

3. Use the **jog shuttle** and **SELECT** to set Interval to 1s or 60min.

If Chart is selected step 2, proceed to step 4.

If File is selected step 2, proceed to step 5.

### Setting the Print Direction (If Chart Is Selected in Step 2)

4. Use the **jog shuttle** and **SELECT** to set Direction to Normal (the newest data is at the top of the paper) or Rotation (the oldest data is at the top of the paper). Proceed to step 8.

### Setting the Output File (If File Is Selected in Step 2)

#### Setting Auto Naming

5. Use the **jog shuttle** and **SELECT** to select Auto Naming from OFF, Numbering, and Date.

#### Setting the File Name

6. Use the **jog shuttle** and **SELECT** to select File Name. Then, enter the file name using up to 16 characters according to the procedure in section 4.2.

#### Selecting the File Output Destination

7. Use the **jog shuttle** and **SELECT** to select File List. Then, select the file output destination according to steps 14 to 17 in section 13.7. Proceed to step 8.

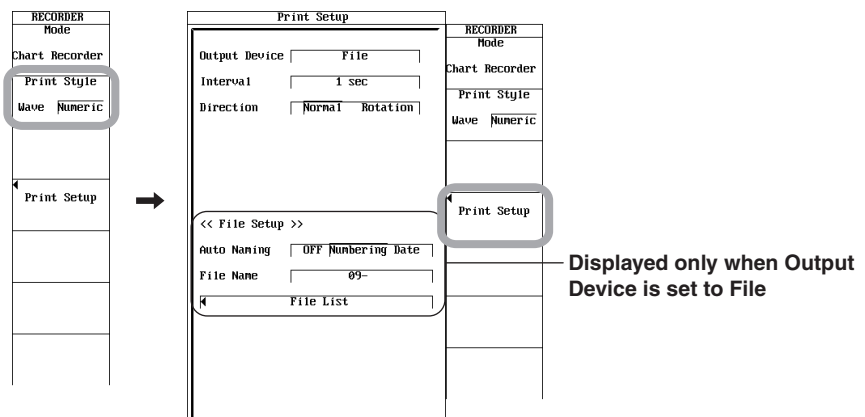

### Note

Up to 10000 lines are output to the file. When 10000 lines are exceeded, writing stops. However, the measurement continues.

**Setting the Trigger Mode**

8. Press **MODE**.
9. Press the soft key corresponding to the desired mode to set the trigger mode to Auto or Log.

**Setting the Acquisition Mode**

Normally, the acquisition mode in Chart Recorder mode is envelope. If you wish to switch to normal mode, carry out steps 10 to 13 below.

10. Press **MISC**.
11. Press the **Next 1/2** soft key
12. Press the **Others** soft key.
13. Press the **Chart Recorder Sample** soft key to set the acquisition mode in Chart Recorder mode to Envelope or Normal.

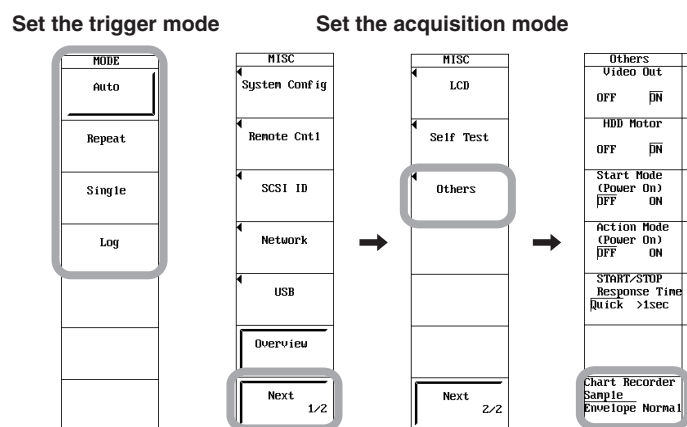
**Starting/Stopping the Numeric Value Recording**

14. Press **START/STOP**. The waveform acquisition starts, and chart recording with numeric values also starts.
15. To stop chart recording with numeric values, press **START/STOP** again. The waveform acquisition stops, and chart recording with numeric values also stops.

**Explanation****Output Device**

To record numeric values on the built-in printer, select Chart. To save numeric values to a file on a specified storage medium, select File.

**Output Interval: Interval**

Select 1 s, 2 s, 5 s, 10 s, 15 s, 20 s, 30 s, 1 min, 2 min, 5 min, 10 min, 15 min, 20 min, 30 min, or 60 min.

**Print Direction: Direction**

If the output destination is set to Chart, set the print direction to Normal (the newest data is at the top of the paper) or Rotation (the oldest data is at the top of the paper).

**Output File: File Setup**

If the output destination is set to File, set the output file (auto naming, file name, and file output destination). These settings are the same as those of normal files. For details, see section 13.7.

**Trigger Mode**

In Chart Recorder mode, you can select the trigger mode from Auto or Log. This is the same as the trigger mode of T-Y recording. For details, see page 2-43 and section 9.3.

**Acquisition Mode**

The acquisition mode in Chart Recorder mode is envelope. However, the mode can be changed to normal mode by using the MISC menu > Others menu.

Envelope and normal modes in Chart Recorder mode are the same as those when recorder mode is disabled. For details, see page 2-31.

**Print Example of Numeric Value Recording**

Interval: 1 s  
Direction: Normal

Paper feed direction →

Date	Record time	Channel number	Unit	Numeric value
14:25:27	14:25:27	CH (1)		-4.05
14:25:28	14:25:28	CH (2)		-4.07
14:25:29	14:25:29	CH (3)		-4.11
14:25:30	14:25:30	CH (4)		-4.06
14:25:31	14:25:31	CH (5)		-4.06
14:25:32	14:25:32	CH (6)		-4.06
14:25:33	14:25:33	CH (7)		-4.06
14:25:34	14:25:34	CH (8)		-4.06
14:25:35	14:25:35	CH (9)		-4.06
14:25:36	14:25:36	CH (10)		-4.06
14:25:37	14:25:37	CH (11)		-4.06
14:25:38	14:25:38	CH (12)		-4.06
14:25:39	14:25:39	CH (13)		-4.06
14:25:40	14:25:40	CH (14)		-4.06
14:25:41	14:25:41	CH (15)		-4.06
14:25:42	14:25:42	CH (16)		-4.06
14:25:43	14:25:43	CH (17)		-4.06
14:25:44	14:25:44	CH (18)		-4.06
14:25:45	14:25:45	CH (19)		-4.06
14:25:46	14:25:46	CH (20)		-4.06
14:25:47	14:25:47	CH (21)		-4.06
14:25:48	14:25:48	CH (22)		-4.06
14:25:49	14:25:49	CH (23)		-4.06
14:25:50	14:25:50	CH (24)		-4.06
14:25:51	14:25:51	CH (25)		-4.06
14:25:52	14:25:52	CH (26)		-4.06
14:25:53	14:25:53	CH (27)		-4.06
14:25:54	14:25:54	CH (28)		-4.06
14:25:55	14:25:55	CH (29)		-4.06
14:25:56	14:25:56	CH (30)		-4.06
14:25:57	14:25:57	CH (31)		-4.06
14:25:58	14:25:58	CH (32)		-4.06
14:25:59	14:25:59	CH (33)		-4.06
14:26:00	14:26:00	CH (34)		-4.06
14:26:01	14:26:01	CH (35)		-4.06
14:26:02	14:26:02	CH (36)		-4.06
14:26:03	14:26:03	CH (37)		-4.06
14:26:04	14:26:04	CH (38)		-4.06
14:26:05	14:26:05	CH (39)		-4.06
14:26:06	14:26:06	CH (40)		-4.06
14:26:07	14:26:07	CH (41)		-4.06
14:26:08	14:26:08	CH (42)		-4.06
14:26:09	14:26:09	CH (43)		-4.06
14:26:10	14:26:10	CH (44)		-4.06
14:26:11	14:26:11	CH (45)		-4.06
14:26:12	14:26:12	CH (46)		-4.06
14:26:13	14:26:13	CH (47)		-4.06
14:26:14	14:26:14	CH (48)		-4.06
14:26:15	14:26:15	CH (49)		-4.06
14:26:16	14:26:16	CH (50)		-4.06
14:26:17	14:26:17	CH (51)		-4.06
14:26:18	14:26:18	CH (52)		-4.06
14:26:19	14:26:19	CH (53)		-4.06
14:26:20	14:26:20	CH (54)		-4.06
14:26:21	14:26:21	CH (55)		-4.06
14:26:22	14:26:22	CH (56)		-4.06
14:26:23	14:26:23	CH (57)		-4.06
14:26:24	14:26:24	CH (58)		-4.06
14:26:25	14:26:25	CH (59)		-4.06
14:26:26	14:26:26	CH (60)		-4.06
14:26:27	14:26:27	CH (61)		-4.06
14:26:28	14:26:28	CH (62)		-4.06
14:26:29	14:26:29	CH (63)		-4.06
14:26:30	14:26:30	CH (64)		-4.06
14:26:31	14:26:31	CH (65)		-4.06
14:26:32	14:26:32	CH (66)		-4.06
14:26:33	14:26:33	CH (67)		-4.06
14:26:34	14:26:34	CH (68)		-4.06
14:26:35	14:26:35	CH (69)		-4.06
14:26:36	14:26:36	CH (70)		-4.06
14:26:37	14:26:37	CH (71)		-4.06
14:26:38	14:26:38	CH (72)		-4.06
14:26:39	14:26:39	CH (73)		-4.06
14:26:40	14:26:40	CH (74)		-4.06
14:26:41	14:26:41	CH (75)		-4.06
14:26:42	14:26:42	CH (76)		-4.06
14:26:43	14:26:43	CH (77)		-4.06
14:26:44	14:26:44	CH (78)		-4.06
14:26:45	14:26:45	CH (79)		-4.06
14:26:46	14:26:46	CH (80)		-4.06
14:26:47	14:26:47	CH (81)		-4.06
14:26:48	14:26:48	CH (82)		-4.06
14:26:49	14:26:49	CH (83)		-4.06
14:26:50	14:26:50	CH (84)		-4.06
14:26:51	14:26:51	CH (85)		-4.06
14:26:52	14:26:52	CH (86)		-4.06
14:26:53	14:26:53	CH (87)		-4.06
14:26:54	14:26:54	CH (88)		-4.06
14:26:55	14:26:55	CH (89)		-4.06
14:26:56	14:26:56	CH (90)		-4.06
14:26:57	14:26:57	CH (91)		-4.06
14:26:58	14:26:58	CH (92)		-4.06
14:26:59	14:26:59	CH (93)		-4.06
14:27:00	14:27:00	CH (94)		-4.06
14:27:01	14:27:01	CH (95)		-4.06
14:27:02	14:27:02	CH (96)		-4.06
14:27:03	14:27:03	CH (97)		-4.06
14:27:04	14:27:04	CH (98)		-4.06
14:27:05	14:27:05	CH (99)		-4.06
14:27:06	14:27:06	CH (100)		-4.06

- Note**
- If the output destination is set to File, measurement does not start when the power is turned ON even if the waveform acquisition mode at power ON (see section 7.1) is turned ON.
  - The print timing may deviate from the specified output interval.

# 9.7 Recording X-Y Waveforms (X-Y Waveform Recording)

<For a description of this function, refer to page 2-46.>

## Procedure

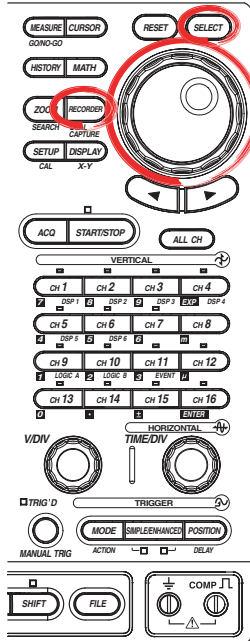

Before carrying out the procedure below, set the recorder mode as follows according to the procedures in section 9.2.

Recorder mode: X-Y Recorder

### Setting the Sample Rate

1. Press the **Sample Rate** soft key.
2. Use the **jog shuttle** to set the sample rate in the range of 5 S/s to 5 kS/s.

### Setting the Interpolation Method

3. Press the **Interpolation** soft key to display the interpolation selection menu.
4. Press the soft key corresponding to the desired interpolation method, **OFF** or **Line**.

### Setting Auto Print

5. Use the **jog shuttle** and **SELECT** to set **Auto Print** to ON or OFF. If ON is selected, X-Y waveform recording on the built-in printer starts automatically when waveform acquisition stops.

### Selecting the X-Y Waveform to Be Recorded (Displayed)

6. Press the **Print Setup** soft key to display the print setup dialog box.
7. Use the **jog shuttle** and **SELECT** to select the X-Y waveform to be recorded (displayed) in the range of XY1 to XY4.

### Setting the Graticule

#### Setting the Graticule

8. Use the **jog shuttle** and **SELECT** to set Type to , OFF, or .

#### Setting Dark/Light

9. Use the **jog shuttle** and **SELECT** to set Dark/Light to Light or Dark.

#### Setting the Width of the Vertical Scale

10. Use the **jog shuttle** and **SELECT** to set Width to 1div or 10mm.

### Note

The graticule setting is linked with the DISPLAY menu > Graticule setting. However, if OFF is selected, the DISPLAY menu is set to .

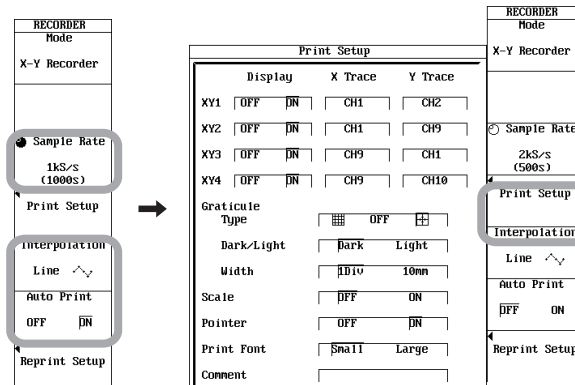



## 9.7 Recording X-Y Waveforms (X-Y Waveform Recording)

### Setting Whether to Print the Scale

11. Use the **jog shuttle** and **SELECT** to set Scale to OFF or ON.

### Setting the Pointer

12. Use the **jog shuttle** and **SELECT** to set Pointer to ON or OFF. If ON is selected, a pointer indicating the most recent recording position appears on the screen.

### Setting the Font Size

13. Use the **jog shuttle** and **SELECT** to set Print Font to Small or Large.

### Setting Comments

14. Use the **jog shuttle** and **SELECT** to select Comment. Then, enter the comment text you wish to print using up to 20 characters according to the procedure in section 4.2.

### Note

- The comment setting is linked with the PRINT menu > Comment setting.
- The pointer is not printed during X-Y waveform recording.

Print Setup				RECORDER Mode	
Display				X-Y Recorder	
	X Trace	Y Trace			
XY1	OFF ON	CH1	CH2		
XY2	OFF ON	CH1	CH9	Sample Rate	
XY3	OFF ON	CH9	CH1	2kS/s (500s)	
XY4	OFF ON	CH9	CH10	Print Setup	
Graticule Type		OFF		Interpolation	
Dark/Light		Dark	Light	Line	
Width		10mm		Auto Print	
Scale		OFF	ON	OFF	ON
Pointer		OFF	ON	Reprint Setup	
Print Font		Small	Large		
Comment					

### Starting/Stopping X-Y Waveform Recording

15. Press **START/STOP**. The waveform acquisition starts, and the screen shows the X-Y waveform.
16. Press **START/STOP**. The waveform acquisition stops.  
If auto print is turned ON in step 4, the X-Y waveform recording starts when the data acquisition stops.

### Note

Use the Reprint Setup menu (see section 9.8) to execute X-Y waveform recording when auto print is turned OFF.

## Explanation

### Sample Rate

Select the sample rate from the following.

5 S/s, 10 S/s, 20 S/s, 50 S/s, 100 S/s, 200 S/s, 500 S/s, 1 kS/s, 2 kS/s, and 5 kS/s

### Interpolation

Set the interpolation format to OFF or Line. For details on the interpolation method, see section 8.2.

### Auto Print

Select whether to automatically perform X-Y waveform recording (printing) on the built-in printer when waveform acquisition is stopped.

### Selecting the X-Y Waveform to Be Recorded (Displayed)

Select the X-Y waveform to be recorded (displayed) in the range of XY1 to XY4.

### Graticule

#### **Type**

Select the graticule type from , OFF, or .

The graticule setting is linked with the DISPLAY menu > Graticule setting. However, if OFF is selected, the DISPLAY menu is set to .

#### **Dark/Light**

Set the graticule Dark/Light setting to Light or Dark.

#### **Scale Width of the X- and Y-Axes: Width**

Select how to set the scale width of the X- and Y-axes. For details on the format of the scale lines that are printed, see page 9-10.

1div: Graticule obtained by dividing the recording area into 10 areas

10mm: mm graticule type

### Scale Printing

Select whether to print the scale.

### Pointer

Select whether to display the pointer that indicates the most recent recording position on the screen.

The pointer is only displayed on the screen; it is not printed during X-Y waveform recording.

### Font Size: Print Font

Select the size of the printed characters to small or large. The setting applies to all printed characters.

### Comment

A comment string of up to 20 characters can be printed at the bottom right section.

### Starting/Stopping X-Y Waveform Recording

When the START/STOP key is pressed, the waveform acquisition starts, and the screen shows the X-Y waveform. Pressing the START/STOP key again stops the waveform acquisition.

If auto print is turned ON, the X-Y waveform recording on the built-in printer starts when the data acquisition stops. The waveform that is acquired between start and stop is recorded.

The Reprint Setup menu (see section 9.8) can be used to execute X-Y waveform recording on the built-in printer when auto print is turned OFF.

The most recent 1 MW of data that are acquired during X-Y waveform recording are saved to the internal memory of the DL750P. The data can be analyzed using automated measurement of waveform parameters\* (see section 11.6), cursor measurements (excluding the marker cursor. See section 11.5), etc. The data can also be saved to a storage medium.

\* Area computation on the X-Y waveform is performed only on XY1.

9.7 Recording X-Y Waveforms (X-Y Waveform Recording)

Print Example of X-Y Waveform Recording

Graticule Type: 

Width: 10 mm

Time Sample rate

0005/01/13 17:17:39 385/s  
TIME: 10.00V

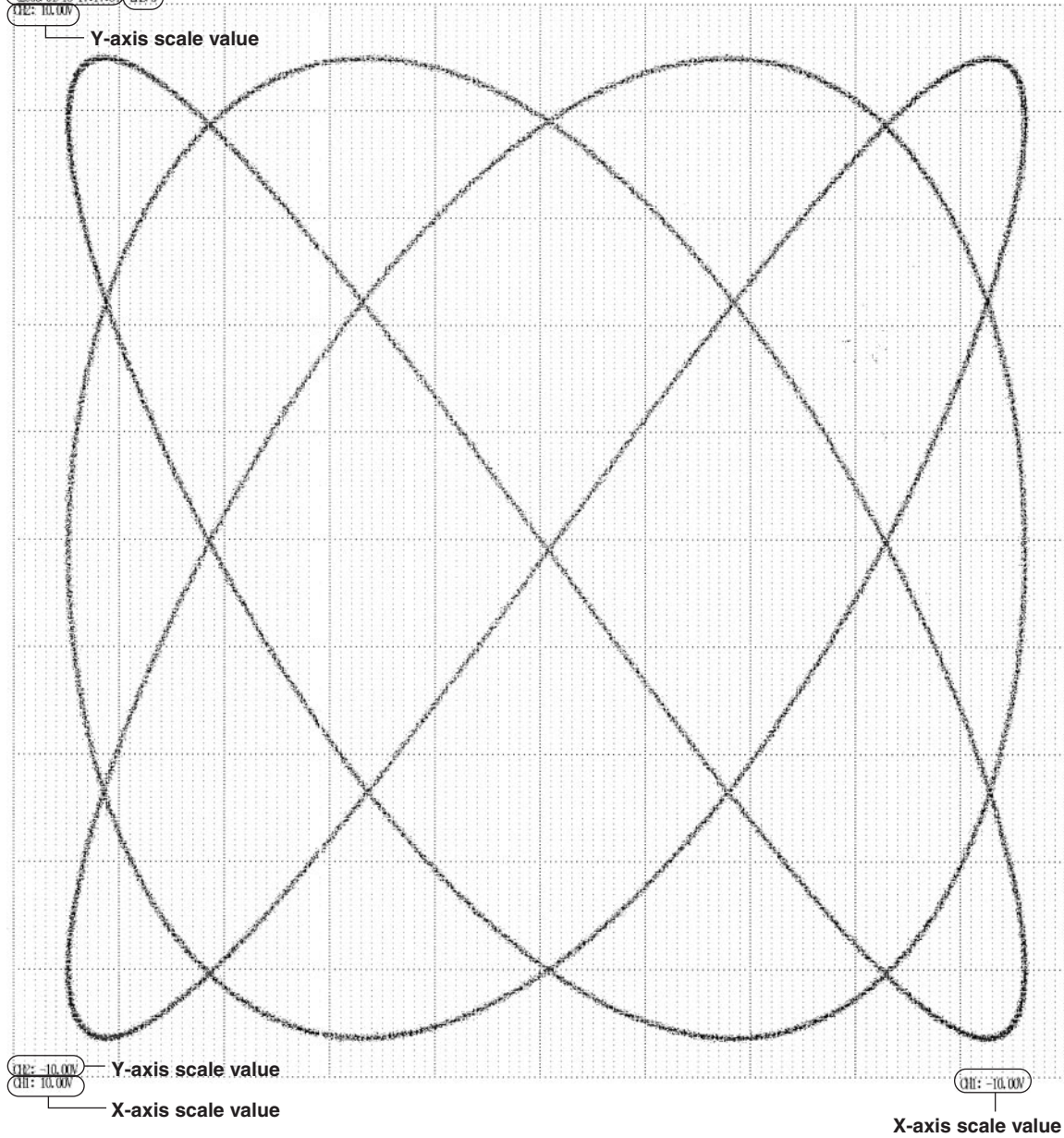

## 9.8 Reprinting on the Built-in Printer

<For a description of this function, refer to page 2-46.>

### Procedure

#### Reprinting the Waveform Recorded in Chart Recorder Mode (T-Y Recording)

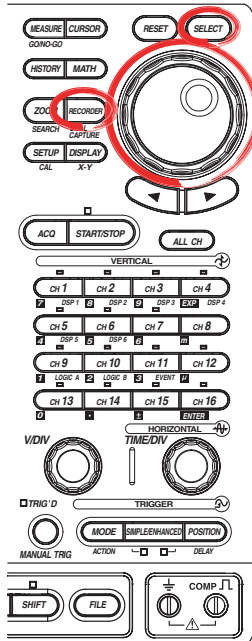

Before carrying out the procedure below, record the T-Y waveform in Chart Recorder mode according to the procedures in sections 9.2 and 9.5.

1. Press the **Reprint Setup** soft key.

#### Setting the Print Destination

2. Press the **Print** to soft key to display the menu used to select the print destination.
3. Press the **Printer** soft key.

#### Selecting the Print Length

4. Press the **Length** soft key to display the menu used to select the print length.
5. Press the **Continue** or **A4 Print** soft key.

#### Selecting the Section to Be Reprinted

6. Press the **Window Mag/Window Pos** soft key to select Window Mag.
7. Use the **jog shuttle** and **SELECT** to set the zoom rate. You can reduce the zoom rate to redisplay the waveform that had been cleared from the screen.
8. Press the **Window Mag/Window Pos** soft key to select Window Pos.
9. Use the **jog shuttle** and **SELECT** to set the zoom position. You can move the zoom position to redisplay the waveform that had been cleared from the screen.
10. If Continue was selected in step 5, press the **Start Point/End Point** soft key.
11. Use the **jog shuttle** and **SELECT** to set the start and end points of the section to be reprinted.

#### Setting the Print Magnification (Only If Continue Is Selected in Step 5)

12. Press the **Print Mag** soft key.
13. Use the **jog shuttle** to set the magnification of the section to be reprinted that was selected in steps 6 to 11. The top section of the menu shows the magnification; the bottom section shows the number of pages when the waveform is recorded using the magnification indicated in the top section.

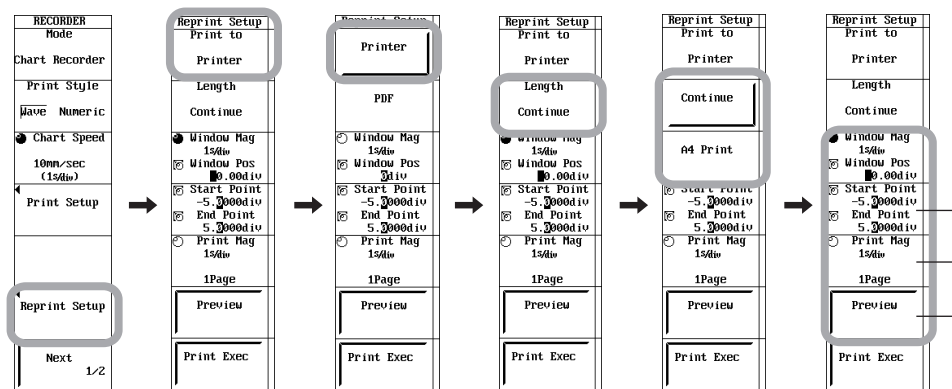

Start Point/End Point, Print Mag, and Preview are displayed only when Length is set to Continue.

## 9.8 Reprinting on the Built-in Printer

### Displaying the Preview (Only If Continue Is Selected in Step 5)

14. Press the **Preview** soft key.
15. Use the **jog shuttle** to select the page you wish to preview.
16. Press the **Quit** soft key. The preview display closes.

### Executing the Reprint Operation

17. Press the **Print Exec** soft key. Reprint is executed using the conditions set in steps 6 to 13.

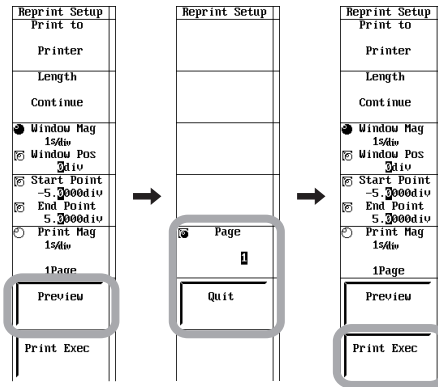

## Reprinting the Waveform Recorded in X-Y Recorder Mode

Before carrying out the procedure below, record the X-Y waveform in X-Y Recorder mode according to the procedures in sections 9.2 and 9.7.

1. Press the **Reprint Setup** soft key.

### Executing the Reprint Operation

2. Press the **Print Exec** soft key.

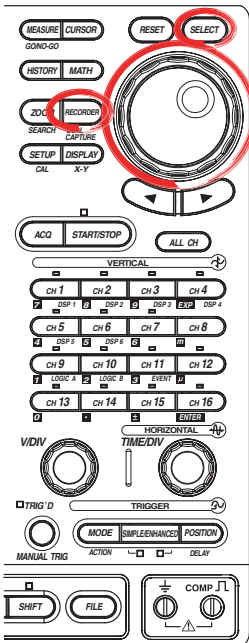
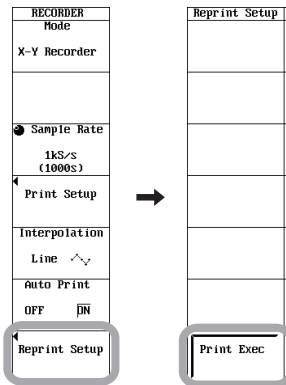

**Explanation**

The measured data of the T-Y waveform recorded in Chart Recorder mode or the measured data of the X-Y waveform recorded in X-Y Recorder mode is stored in the internal memory.

**Reprinting the Waveform Recorded in Chart Recorder Mode (T-Y Waveform Recording)**

**Print to**

To reprint the waveform recorded in Chart Recorder mode (T-Y waveform recording), set the print destination to Printer (built-in printer).

**Length**

Continue: Prints the range specified by Window Mag/Window Pos and Start Point/End Point using the magnification specified by Print Mag.

A4 Print: Prints the range specified by Window Mag/Window Pos and Start Point/End Point to A4 size. The magnification changes automatically so that the specified print range fits on an A4 size paper.

**Selecting the Section to Be Reprinted**

**Zoom Rate/Zoom Position: Window Mag/Window Pos**

When selecting the section to be reprinted, Window Mag is used to reduce the zoom rate in order to redisplay the waveform that has been cleared from the screen. You can also move Window Pos to redisplay the waveform that had been cleared from the screen.

**Start Point/End Point**

If Length is set to Continue, display the section to be reprinted on screen, and then use Start Point and End Point to set the start and end points.

After displaying the section to be reprinted on screen, use Start Point and End Point to set the start and end points.

**Print Magnification: Print Mag**

Set Print Mag on when Length is set to Continue.

Set the waveform magnification for reprinting. The top section of the menu shows the magnification; the bottom section shows the number of pages when the waveform is recorded using the magnification indicated in the top section.

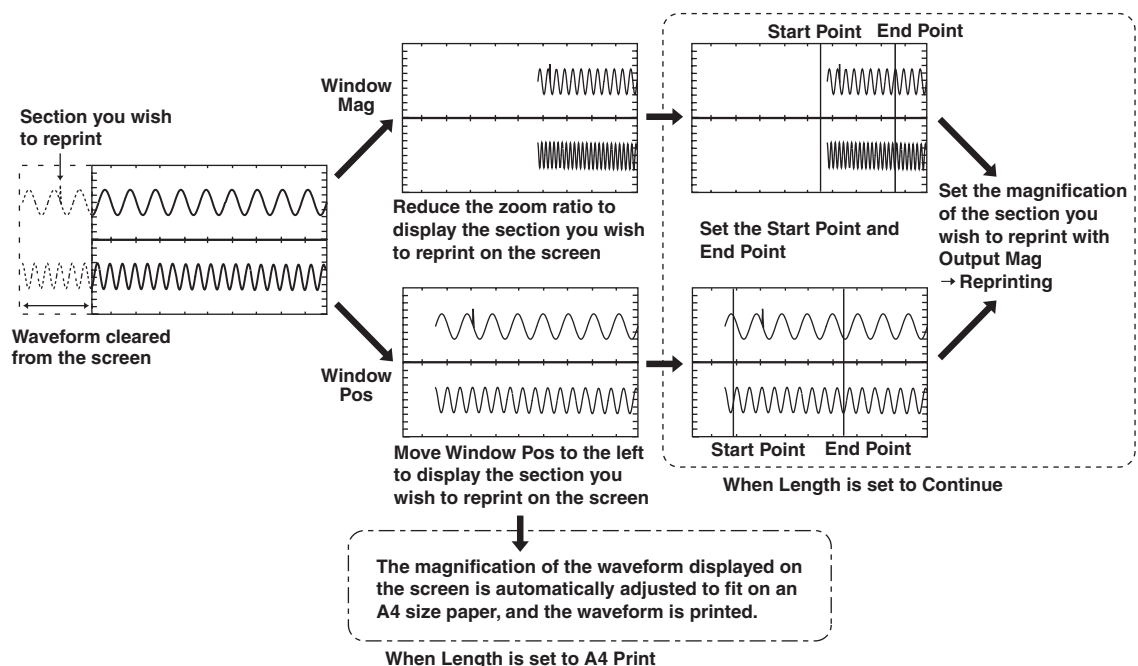

## 9.8 Reprinting on the Built-in Printer

---

### **Preview**

Displays a preview of the section that you wish to reprint. Press the Quit soft key to close the preview display.

### **Executing the Reprint Operation: Print Exec**

Reprint is executed using the specified conditions.

## **Reprinting the Waveform Recorded in X-Y Recorder Mode (X-Y Waveform Recording)**

### **Executing the Reprint Operation: Print Exec**

The measured data recorded to the internal memory immediately before in X-Y Recorder mode is reprinted as a waveform.

**Reprint Example of T-Y Waveform Recording**

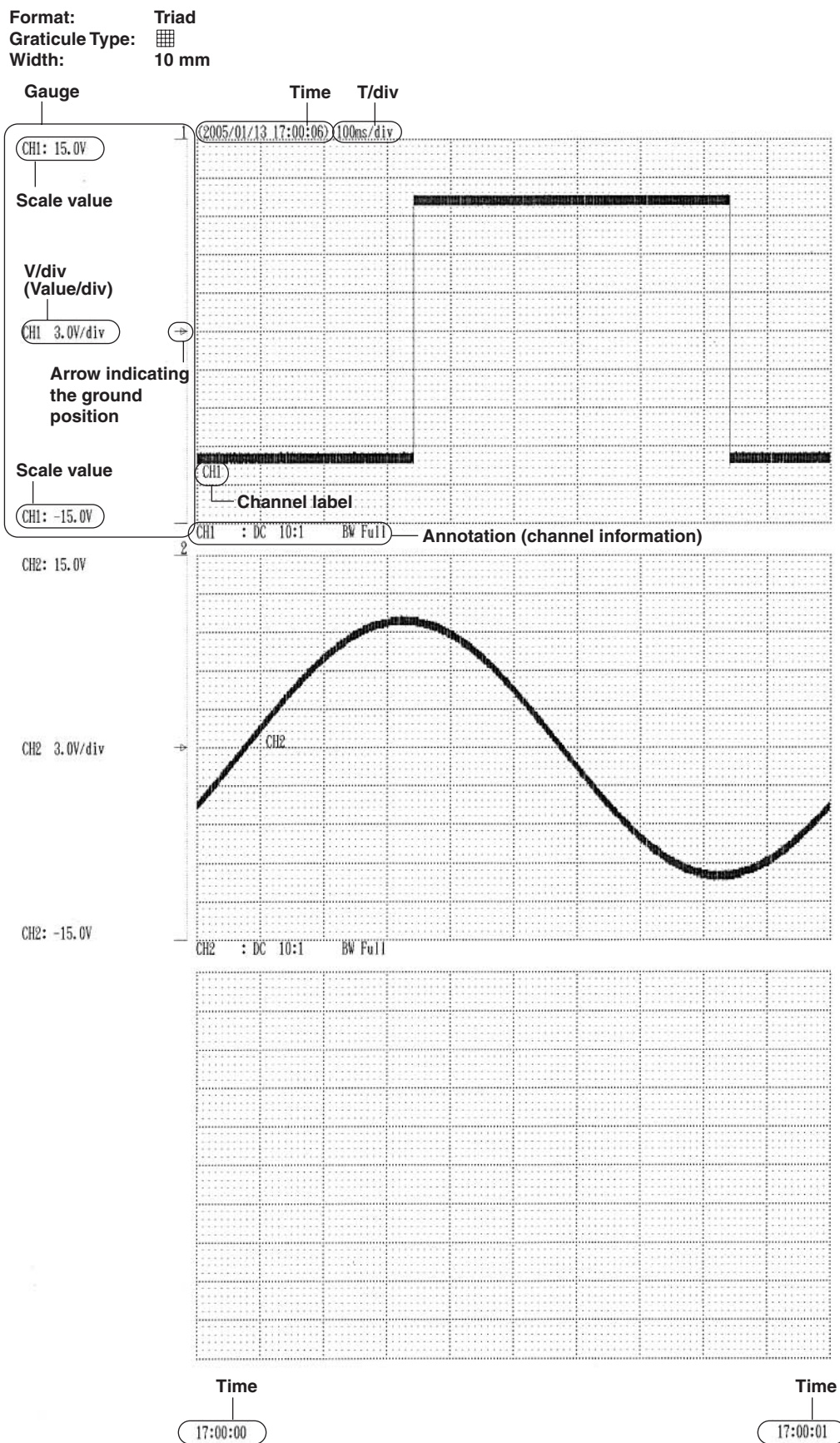

**6** Recording in Recorder Mode (Realtime Recording) (Only on the DL750P)



## 9.9 Creating a PDF File of the Reprint Image

<For a description of this function, refer to page 2-46.>

### Procedure

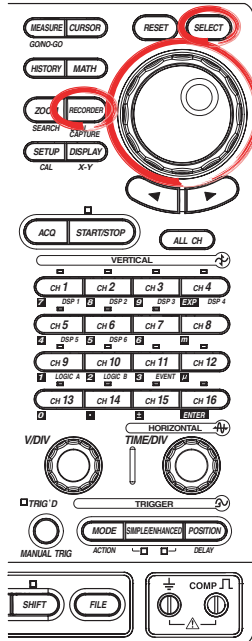

Before carrying out the procedure below, record the T-Y waveform in Chart Recorder mode according to the procedures in sections 9.2 and 9.5, or record the X-Y waveform in X-Y Recorder mode according to the procedures in section 9.7.

1. Press the **Reprint Setup** soft key.

### Setting the Print Destination

2. Press the **Print to** soft key to display the menu used to select the print destination.
3. Press the **PDF** soft key.

In Chart Recorder mode, proceed to step 4.

In X-Y Recorder mode, proceed to step 12.

### Selecting the Section to Be Output to the PDF File (Only When the Chart Recorder Mode)

4. Press the **Window Mag/Window Pos** soft key to select Window Mag.
5. Use the **jog shuttle** and **SELECT** to set the zoom rate. You can reduce the zoom rate to redisplay the waveform that had been cleared from the screen.
6. Press the **Window Mag/Window Pos** soft key to select Window Pos.
7. Use the **jog shuttle** and **SELECT** to set the zoom position. You can move the zoom position to redisplay the waveform that had been cleared from the screen.
8. Press the **Start Point/End Point** soft key.
9. Use the **jog shuttle** and **SELECT** to set the start and end points of the section to be output to the PDF file.

### Setting the Print Magnification (Only When the Chart Recorder Mode)

10. Press the **Print Mag** soft key.
11. Use the **jog shuttle** to set the magnification of the section to be output to the PDF file that was selected in steps 4 to 9. The top section of the menu shows the magnification; the bottom section shows the number of pages when the waveform is recorded using the magnification indicated in the top section.

#### When the Chart Recorder Mode

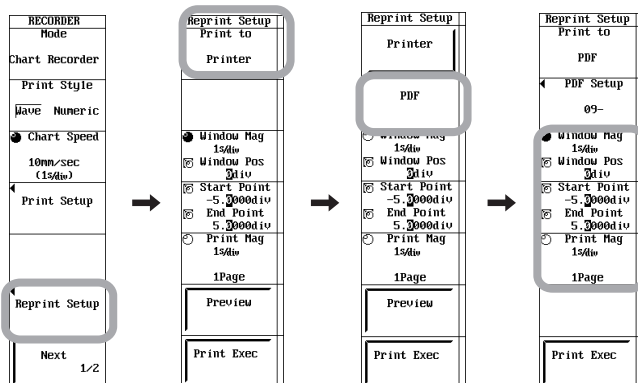

#### When the X-Y Recorder Mode

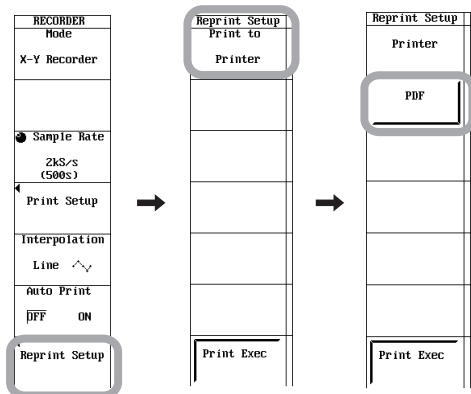

**Setting the PDF File**

12. Press the **PDF Setup** soft key to display the PDF setup dialog box.

**Setting the Paper Size**

13. Use the **jog shuttle** and **SELECT** to set Paper Size to Built-in Printer, A3, A4, or A5.

**Setting the Orientation (If A3, A4, or A5 was selected in step 13)**

14. Use the **jog shuttle** and **SELECT** to set Orientation to Landscape or Portrait.

**Setting the Number of Divisions per Page (If A3, A4, or A5 was selected in step 13 (Only When the Chart Recorder Mode))**

15. Use the **jog shuttle** and **SELECT** to set Div/Page.

**Setting Document Information**

16. Use the **jog shuttle** and **SELECT** to select Title, Author, Sub Title, or KeyWord. Enter the title, author, sub title of the PDF file using up to 30 characters and the keyword using up to 90 characters according to the procedure given in section 4.2.

**Setting the Color**

17. Use the **jog shuttle** and **SELECT** to set Color to OFF or ON.

**Enabling/Disabling Compression**

18. Use the **jog shuttle** and **SELECT** to set Compression to ON or OFF.

**Setting Auto Naming**

19. Use the **jog shuttle** and **SELECT** to select Auto Naming from OFF, Numbering, and Date.

**Setting the PDF File Name**

20. Use the **jog shuttle** and **SELECT** to select File Name. Then, enter the file name using up to 16 characters according to the procedure in section 4.2.

**Selecting the Output Destination of the PDF File**

21. Use the **jog shuttle** and **SELECT** to select File List. Then, select the file output destination according to steps 14 to 17 in section 13.7.

**Executing the PDF File Generation**

22. Press the **Print Exec** soft key. A PDF file is created using the conditions set in steps 4 to 21.

When the Chart Recorder Mode

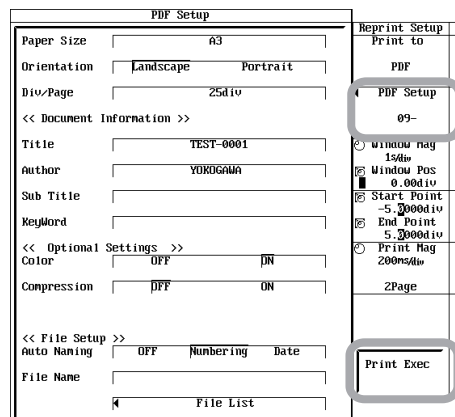

When the X-Y Recorder Mode

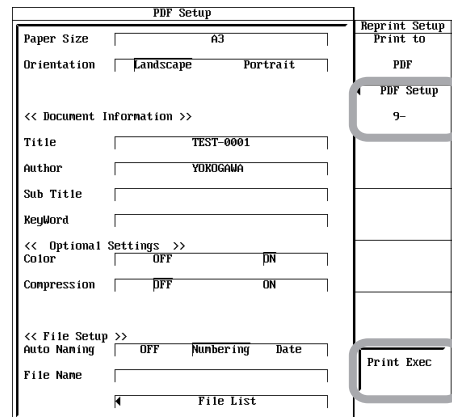

**Explanation**

**Print to**

When creating a PDF file of the waveform recorded in Chart Recorder mode (T-Y recording) or X-Y Recorder mode, set the print destination to PDF.

**Selecting the Section to Be Output to the PDF File: Window Mag/Window Pos and Start Point/End Point**

Can be specified only in Chart Recorder mode. These are the same as Window Mag/Window Pos and Start Point/End Point when reprinting on the built-in printer. See page 9-23.

**Print Magnification: Print Mag**

Can be specified only in Chart Recorder mode. This is the same as Print Mag when reprinting on the built-in printer. See page 9-23.

**Setting the PDF File**

**Paper Size**

Select the paper size from built-in printer size, A3, A4, and A5. If the built-in printer size is selected, a PDF file is created of an image similar to the printed output on the built-in printer (A4 size).

**Orientation**

If the paper size is set to A3, A4, or A5, set the orientation of the PDF file to Landscape or Portrait.

**Number of Divisions per Page: Div/Page**

Can be specified only in Chart Recorder mode. If the paper size is set to A3, A4, or A5, set the number of divisions to be printed per page in the PDF file. The specified number of divisions is printed per page. The selectable range varies depending on the paper size, orientation, and gauge (see section 9-11) as follows:

Paper Size	Orientation	Selectable Range of Div/Page	
		Gauge: OFF	Gauge: ON
Built-In Printer	-	20 (fixed)	20 (fixed)
A3	Portrait	1 to 25	1 to 20
A3	Landscape	1 to 40	1 to 35
A4	Portrait	1 to 20	1 to 15
A4	Landscape	1 to 25	1 to 20
A5	Portrait	1 to 10	1 to 10
A5	Landscape	1 to 20	1 to 15

**Document Information: Title, Author, Sub Title, and KeyWord**

As necessary, enter the title, author, sub title, and keyword of the PDF file to be created.

**Color**

The PDF file is created in color if ON is selected and monochrome if OFF is selected.

**Compression**

Select whether to compress the file. If ON is selected, the file is compressed. However, the generation of the PDF file takes longer than when OFF is selected.

### **File Setup**

Set the auto naming, file name, and file output destination of the PDF file. These settings are the same as those of normal files. For details, see section 13.7.

### **Executing the PDF File Generation**

The PDF file is created using the specified conditions. The extension to the PDF file is .pdf.

9.9 Creating a PDF File of the Reprint Image

PDF File Example

When the Chart Recorder Mode (Paper Size: A4)

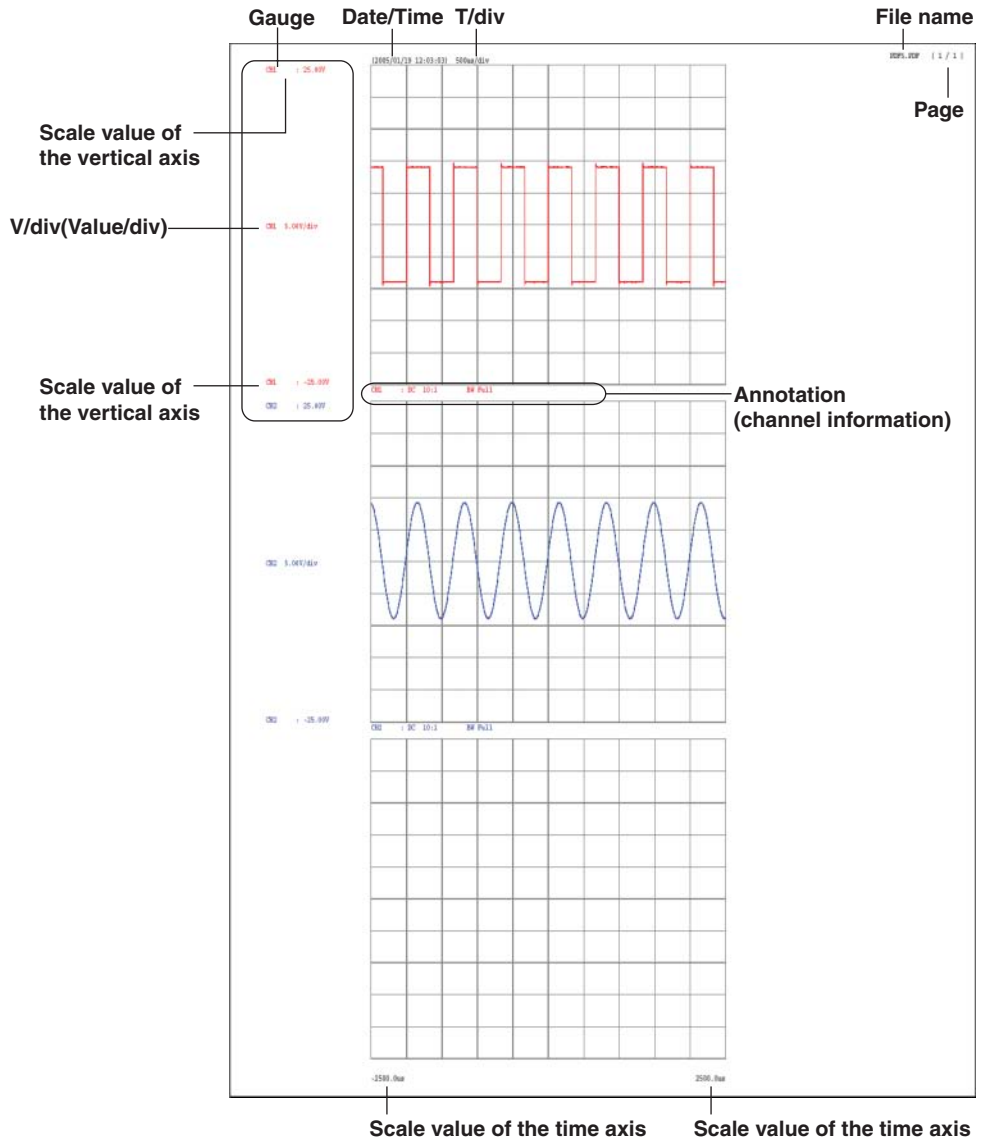

When the X-Y Recorder Mode (Paper Size: A5)

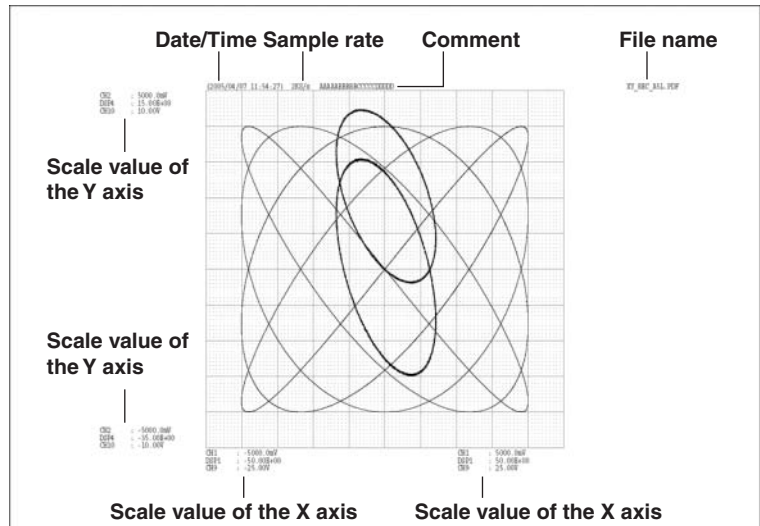

**DL750/DL750P**  
**ScopeCorder**

**USER'S MANUAL**

---

**Part 1**   **Part 2**

***GiGAZoom***  
ENGINE™

---

Thank you for purchasing the DL750/DL750P ScopeCorder.

This user's manual contains useful information about the instrument's functions and operating procedures and lists the handling precautions of the DL750/DL750P. It mainly focuses on the DL750. The user's manual is divided into two parts, Part 1 and Part 2. For details on the information covered in Part 1 and Part 2 as well as other DL750/DL750P manuals, see "Manuals That Come with the DL750/DL750P" on the next page. To ensure correct use, please read this manual thoroughly before beginning operation. After reading the manual, keep it in a convenient location for quick reference whenever a question arises during operation.

## Notes

- The contents of this manual are subject to change without prior notice as a result of continuing improvements to the instrument's performance and functions. The figures given in this manual may differ from those that actually appear on your screen.
- Every effort has been made in the preparation of this manual to ensure the accuracy of its contents. However, should you have any questions or find any errors, please contact your nearest YOKOGAWA dealer.
- Copying or reproducing all or any part of the contents of this manual without the permission of Yokogawa Electric Corporation is strictly prohibited.
- The TCP/IP software of this product and the document concerning the TCP/IP software have been developed/created by YOKOGAWA based on the BSD Networking Software, Release 1 that has been licensed from University of California.

## Trademarks

- Microsoft, Internet Explorer, MS-DOS, Windows, Windows NT, and Windows XP are either registered trademarks or trademarks of Microsoft Corporation in the United States and/or other countries.
- Adobe, Acrobat, and PostScript are trademarks of Adobe Systems Incorporated.
- Zip is either a registered trademark or trademark of Iomega Corporation in the United States and/or other countries.
- UNIX is either a registered trademark or trademark of The Open Group in the United States and/or other countries.
- Piezotron is a registered trademark of Kistler Instrument Corporation.
- ICP is a registered trademark of PCB Piezotronics Incorporated.
- ISOTRON is a registered trademark of ENDEVCO Corporation.
- GIGAZOOM ENGINE are pending trademark of Yokogawa Electric Corporation.
- For purposes of this manual, the TM and ® symbols do not accompany their respective trademark names or registered trademark names.
- Other company and product names are trademarks or registered trademarks of their respective holders.

## Revisions

- 1st Edition: February 2005
- 2nd Edition: May 2005
- 3rd Edition: December 2005
- 4th Edition: May 2009

# Manuals That Come with the DL750/DL750P

## DL750/DL750P Manuals

The following manuals are provided for the DL750/DL750P. Use them according to your application.

### User's Manual Part 1

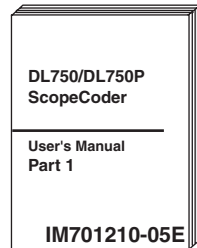

This manual. Contains chapters 1 to 9 of the DL750/DL750P User's Manual. Mainly describes the basic operations of the DL750/DL750P up to waveform acquisition.

#### [Contents]

- **Chapter 1** **Names and Functions of Parts**
- **Chapter 2** **Explanation of Functions**
- **Chapter 3** **Making Preparations for Measurements**
- **Chapter 4** **Common Operations**  
Operations and functions of keys and the jog shuttle, entering values and strings, operations on the USB keyboard/USB mouse, initializing settings, auto setup, calibration, and help function
- **Chapter 5** **Horizontal and Vertical Axes**
- **Chapter 6** **Triggering**
- **Chapter 7** **Acquisition and Display**  
Record length, acquisition mode, sequential store, dual capture, realtime recording to the internal hard disk, voice memo, and acquisition memory backup
- **Chapter 8** **Waveform Display and Information Display**
- **Chapter 9** **Recording in Recorder Mode (Realtime Recording) (DL750P Only)**
- **Index** Common to Part 1 and Part 2.

### User's Manual Part 2

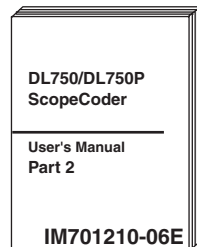

Contains chapters 10 to 19 and appendix of the DL750/DL750P User's Manual. Mainly describes operations after waveform acquisition and optional functions.

#### [Contents]

- **Chapter 10** **Waveform Computation**
- **Chapter 11** **Waveform Analysis/Search**  
Displaying of history waveforms, history search, search & zoom, cursor measurements, automated measurement of waveform parameters, statistical processing, and GO/NO-GO determination
- **Chapter 12** **Printing the Screen Image Data**
- **Chapter 13** **Saving and Loading Data**
- **Chapter 14** **External Trigger I/O, External Clock Input, and Video Signal Input**
- **Chapter 15** **Using the DSP Channel (Optional)**
- **Chapter 16** **Ethernet Interface (Optional)**
- **Chapter 17** **Other Operations**  
Changing the menu/message language, turning the click sound ON/OFF, changing the USB keyboard language, checking the USB keyboard, setting the screen color/brightness, setting the backlight, and locking the keys
- **Chapter 18** **Troubleshooting, Maintenance, and Inspection**
- **Chapter 19** **Specifications**
- **Appendix**
- **Index** Common to Part 1 and Part 2.



### Operation Guide

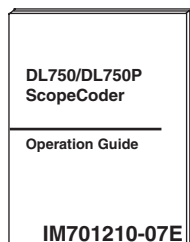

Familiarizes the first-time user with the basic operations of the DL750/DL750P. Latter half of the guide summarizes key points of each setup menu. Use this as a guide when setting up the DL750/DL750P.

**[Contents]**

- **Flow of DL750/DL750P Operation**
- **Front Panel Controls**
- **Parts of the Screen**
- **Basic Key & Jog Shuttle Operations**
- **Main Functions of the DL750/DL750P**
- **Operating the DL750/DL750P**  
 Making preparations before observation, displaying waveforms, changing the waveform display conditions, changing the trigger settings, measuring waveforms, zooming the waveform along the time axis, and printing/saving waveforms
- **Setup Menu Items**

### Communication Interface User's Manual



A manual in PDF format that is stored in the accompanying CD-ROM. Describes the functions of each communication interface on the DL750/DL750P and commands.

**[Contents]**

- **Chapter 1 Overview of the GP-IB Interface**
- **Chapter 2 Overview of the Serial (RS-232) Interface**
- **Chapter 3 Overview of the USB Interface**
- **Chapter 4 Overview of the Ethernet Interface (Optional)**
- **Chapter 5 Before Programming**
- **Chapter 6 Commands**
- **Chapter 7 Status Reports**
- **Chapter 8 Sample Programs**
- **Appendix**
- **Index**

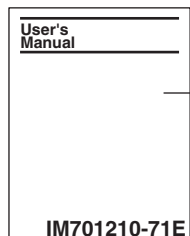

**Handling of the Communication Interface User's Manual CD-ROM**

Describes the handling precautions of the Communication Interface User's Manual CD-ROM.

# Functions Described in This Manual and the DL750/ DL750P Version

The contents of this manual describe the DL750/DL750P version 6.20 or later. The table below shows the relationship between the DL750/DL750P versions and the new functions and supported modules. If the DL750/DL750P is not of the newest version, you will not be able to use all the functions covered in this manual. Check the DL750/DL750P version by referring to Soft Version on the overview screen that appears by selecting the MISC key > Overview soft key. For details on the procedure, see section 18.4 in the User's Manual Part 2. For up-to-date information about the DL750/DL750P versions and the procedure for upgrading your DL750/DL750P, check the following Web page.

<http://www.yokogawa.com/tm/DL750/>

## DL750/DL750P Versions and New Functions

Version	Suffix Code	New Functions	Reference Page/Section/Chapter
1.09 or later	Standard	<ul style="list-style-type: none"> <li>Voice memo and voice comment</li> </ul>	<i>Pages 2-36 and 2-64, sections 7.9 and 13.19</i>
2.02 or later	Standard  /G3	<ul style="list-style-type: none"> <li>Wave window trigger</li> <li>Cycle statistical processing</li> <li>Chinese menu and message support</li> <li>DSP channels</li> </ul>	<i>Page 2-26 and section 6.17 Page 2-57 and section 11.7 Section 17.1 Page 2-50, chapter 15, and appendix 6</i>
3.01 or later	Standard  /G3	<ul style="list-style-type: none"> <li>Numeric monitor display</li> <li>Added exponential window to FFT computation/increased number of points in FFT computation (up to 100 kpoints).</li> <li>Normal statistical processing/statistical processing of history memory</li> <li>Increased the number of parameters for automated measurement/statistical processing of waveform parameters (Up to 24000 increased to up to 48000)</li> <li>Added waveform data save formats for action-on-trigger and GO/NO-GO determination (select from binary, ASCiI, and floating)</li> <li>Support for inverted display on the strain module</li> <li>Support for current probe (701931)</li> <li>Support for enhanced trigger (OR trigger and window trigger) on DSP channels</li> <li>Knocking filter</li> </ul>	<i>Page 2-39 and section 8.13 Page 2-47, section 10.5, page app-21 Page 2-57 and section 11.7 Sections 11.6 and 11.7  Pages 2-29 and 2-58, and Section 13.7 Page 2-14 and section 5.12 Page 2-9 and section 3.6 Pages 2-22 and 2-26, chapter 15 Section 15.6</i>
3.10 or later	Standard	<ul style="list-style-type: none"> <li>Added Korean to the menu languages. Added Korean, German, French, and Italian to message languages.</li> </ul>	<i>Section 17.1</i>
4.01 or later	Standard  Standard, /G3 /C10  /DC	<ul style="list-style-type: none"> <li>Changed the number of screens that can be captured on the dual capture function</li> <li>Selection of the traces to be displayed on the dual capture function</li> <li>Mail transmission using the dual capture trigger function</li> <li>Automated measurement of waveform parameters on the dual capture function</li> <li>Added the action on stop function.</li> <li>Parameter search of the history memory function</li> <li>Added H&amp;V cursor measurement to T-Y waveforms</li> <li>Filter Hz display</li> <li>SNTF function</li> <li>WebDAV server function</li> <li>Mail attachment function of image data</li> <li>Added the DC power supply option (DL750 only)</li> </ul>	<i>Page 2-34 and section 7.6  section 7.6 section 7.6 section 11.6  section 7.8 section 11.3 section 11.5 Sections 10.5 and 15.3 Sections 3.5 and 16.8 Section 16.11 Section 16.5 Section 3.4</i>
4.02 or later	Standard	<ul style="list-style-type: none"> <li>START/STOP key response time</li> </ul>	<i>Section 7.1</i>
5.01 or later	Standard	<ul style="list-style-type: none"> <li>Recording in recorder mode (DL750P only)</li> <li>Connection of USB storage device to the USB PERIPHERAL interface (DL750P only)</li> <li>Creation of PDF files of the printed image (DL750P only)</li> <li>Support for current probe (701933)</li> <li>Added 16 divided windows to the display format</li> <li>Added the output format to the built-in printer (Zoom Print) and changed the name of the function Long copy to Fine print</li> <li>Added the linear scaling display format</li> </ul>	<i>Chapter 9 Section 13.3  Section 13.13 Page 2-9 and section 3.6 Section 8.1 Section 12.2  Section 5.11</i>
6.01 or later	Standard  Standard, /G2	<ul style="list-style-type: none"> <li>Creation of PDF files of the reprint image in X-Y Recorder Mode (DL750P only)</li> <li>Creation of PDF files of the printed image (X-Y waveform) (DL750P only)</li> <li>Overall value display of the power spectrum computation (FFT)</li> </ul>	<i>Section 9.9  Section 13.3 Section 10.13, 10.5, 11.6, and page App-19</i>

## Functions Described in This Manual and the DL750/DL750P Version

Version	Suffix Code	New Functions	Reference Page/Section/Chapter
6.02 or later	Standard	<ul style="list-style-type: none"> <li>Connection of USB storage device to the USB PERIPHERAL interface (DL750)*</li> </ul>	<a href="#">Section 13.3</a>
6.20 or later	Standard	<ul style="list-style-type: none"> <li>Added waveform icons to the title of the CH/DSP/LOGIC/EVENT setup menus.</li> <li>Added All ON of Variable (Var.) to the all channel setup menu.</li> <li>Added ACQ Count to the action-on-trigger/action-on-stop setup menu.</li> <li>Added bandwidth limit to the channel information during temperature/strain measurement.</li> </ul>	<a href="#">Section 5.1</a> <a href="#">Section 5.13 (section 5.9)</a> <a href="#">Sections 6.18 and 7.8</a> <a href="#">Section 8.13</a>
		[Recording in recorder mode (DL750P only)] <ul style="list-style-type: none"> <li>Added an Extra Area ON/OFF function when the format is set to Dual, Triad, or Quad in the print settings of Chart Recorder mode.</li> <li>Added the Fine setting to Gauge in the print settings of Chart Recorder mode.</li> <li>Added A4 print to the print length during reprint in Chart Recorder mode.</li> <li>Selection of the print font size (Print Font) in the print settings of X-Y Recorder mode.</li> </ul>	<a href="#">Section 9.4</a> <a href="#">Section 9.4</a> <a href="#">Section 9.8</a> <a href="#">Section 9.7</a>
		<ul style="list-style-type: none"> <li>Support for phase shift even when external clock is selected.</li> </ul>	<a href="#">Section 10.4</a>
		[Printing on the built-in printer (DL750P only)] <ul style="list-style-type: none"> <li>Added A4 print to the output format.</li> <li>Added an Extra Area ON/OFF function when the format is set to Dual, Triad, or Quad in the print settings of fine print, zoom print, and A4 print.</li> <li>Added the Fine setting to Gauge in the print settings of fine print, zoom print, and A4 print.</li> <li>Creation of PDF files of the print image when all waveform display (Display Mode: All) is selected in the history memory function (DL750P only).</li> </ul>	<a href="#">Section 12.2</a> <a href="#">Section 12.2</a> <a href="#">Section 12.2</a> <a href="#">Section 13.13 (section 11.1)</a>
		<ul style="list-style-type: none"> <li>Added a function for switching the screen display font size (large or small).</li> </ul>	<a href="#">Chapter 17</a>
	/G2	<ul style="list-style-type: none"> <li>Added DUTYH and DUTYL to the user-defined computation.</li> </ul>	<a href="#">Section 10.5</a>

\* Applicable to DL750s on which "USB Storage: Yes" is displayed on the overview screen that appears when you press the MISC key followed by the Overview soft key.

## DL750/DL750P Versions and Supported Modules

Version	Supported Modules Reference Page Vertical Axis Settings	Specifications Concerning Horizontal/	Reference Section
1.07 or later	701250 High-Speed 10 MS/s, 12-Bit Isolation Module 701251 High-Speed High-Resolution 1 MS/s, 16-Bit Isolation Module 701265 Temperature, High Precision Voltage Isolation Module	<a href="#">Page 19-18</a> <a href="#">Page 19-20</a> <a href="#">Page 19-29</a>	<a href="#">Sections 5.1 to 5.15</a> <a href="#">Sections 5.1 to 5.15</a> <a href="#">Sections 5.1, 5.2, 5.5, 5.7, 5.13, 5.14, and 5.16</a>
2.02 or later	701255 High-Speed 10 MS/s, 12-Bit Non-Isolation Module 701260 High-Voltage 100 kS/s, 16-Bit Isolation Module (with RMS) 701270 Strain Module (NDIS) 701271 Strain Module (DSUB, Shunt-Cal)	<a href="#">Page 19-22</a> <a href="#">Page 19-24</a> <a href="#">Page 19-31</a> <a href="#">Page 19-33</a>	<a href="#">Sections 5.1 to 5.15</a> <a href="#">Sections 5.1 to 5.15</a> <a href="#">Sections 5.1, 5.2, 5.7, 5.11 to 5.14, and 5.17</a> <a href="#">Sections 5.1, 5.2, 5.7, 5.11 to 5.14, and 5.17</a>
3.01 or later	701275 Acceleration/Voltage Module (with AAF) 701280 Frequency Module	<a href="#">Page 19-35</a> <a href="#">Page 19-37</a>	<a href="#">Sections 5.1, 5.2, 5.4, 5.5, 5.7 to 5.9, 5.13, 5.14, and 5.18*</a> <a href="#">Sections 5.19, 5.1, 5.2, 5.4, 5.8 to 5.11, 5.13, and 5.14</a>
5.01 or later	701261 Universal (Voltage/Temp.) Module 701262 Universal (Voltage/Temp.) Module (with AAF)	<a href="#">Page 19-26</a> <a href="#">Page 19-26</a>	<a href="#">Sections 5.1, 5.2, 5.4, 5.5, 5.7 to 5.9, 5.13, and 5.14</a> <a href="#">Sections 5.1, 5.2, 5.4, 5.5, 5.7 to 5.9, 5.13, and 5.14</a>

\* Reference section for acceleration measurement.

# Flow of Operation

The figure below provides an overview of the flow of operations described in this manual. For a description of each item, see the relevant chapter or section.

From "Waveform Acquisition" of User's Manual Part 1 (see page Part 1: xv)

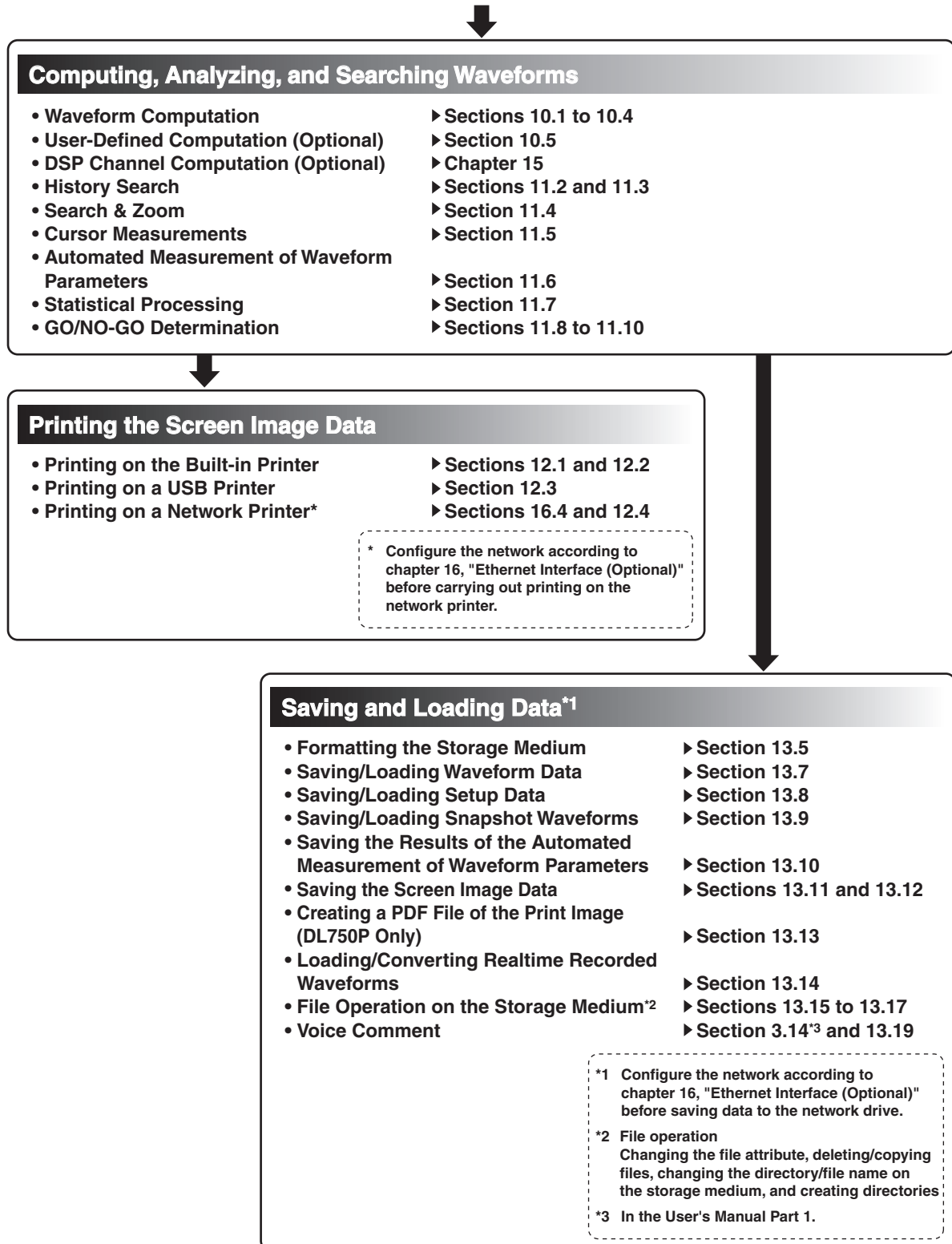

Ethernet interface and other operations do not have to be configured in order from previous chapter. They can be configured independently.

### Ethernet Interface (Optional)

- Connecting the DL750/DL750P to the PC\* ▶ Section 16.1
- ↓
- Setting TCP/IP ▶ Section 16.2
- ↓
- Saving/Loading data on a network drive (FTP client function) ▶ Section 16.3
- Transmitting E-mail messages ▶ Section 16.5
- Accessing the DL750/DL750P from the PC\* (FTP server function) ▶ Section 16.6
- Web server function ▶ Section 16.7
- Using as a Windows network drive ▶ Section 16.11

\* PC or workstation

### Other Operations

- Setting the menu/message language ▶ Section 17.1
- Turning click sound ON/OFF ▶ Section 17.1
- Setting the USB keyboard language ▶ Section 17.3
- Setting the screen color and intensity ▶ Section 17.4
- Setting the backlight ▶ Section 17.5
- Locking the keys ▶ Section 17.6

The functions below that are not covered in the flow of operations in this section are not explained in this manual. For their descriptions, see the User's Manual Part 1 (IM701210-05E).

- Making preparations for measurements
- Displaying waveforms on the screen
- Setting the horizontal and vertical axes
- Setting the trigger
- Acquiring waveforms
- Displaying waveforms and information
- Recording in recorder mode (DL750P only)

# 10.1 Adding, Subtracting, Multiplying, and Dividing Waveforms

<For a description of this function, refer to page 2-47.>

## Procedure

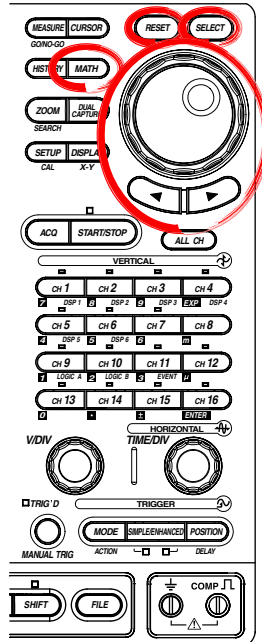

1. Press **MATH**.
2. Press the **Mode** soft key to select ON.

### Setting the Computation Start and End Points

3. Press the **Start Point/End Point** soft key to set the jog shuttle control to Start Point.
4. Turn the **jog shuttle** to set the computation start point.
5. Likewise, set the End Point.

### Setting the Computation

6. Press the **Setup** soft key. The Math1 to Math8 setup dialog boxes appear.
7. Use the **jog shuttle** and **SELECT** to select the Math waveform you wish to set. The corresponding Math waveform setup dialog box appears.

### Setting the Computing Operation

8. Use the **jog shuttle** and **SELECT** to set Operation to S1+S2, S1-S2, S1\*S2, or S1/S2.

### Selecting the Channel on Which to Perform Computation

9. Use the **jog shuttle** and **SELECT** to select Source1.
10. Likewise, select Source2.

### Setting the Scaling

11. Use the **jog shuttle** and **SELECT** to set Scale to Auto or Manual. If you select Manual, proceed to step 9; if you select Auto, proceed to step 11.

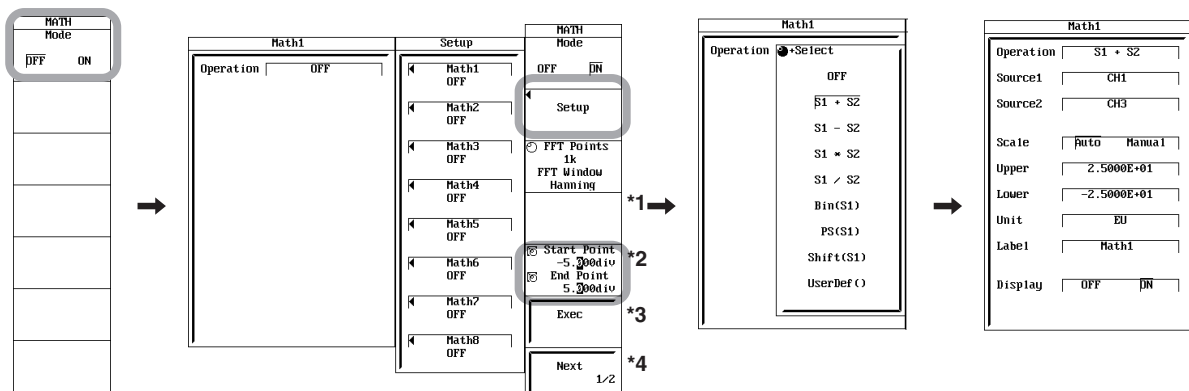

Above is the menu when the user-defined computation option is installed.

The menu on models without the option is as follows: \*1: Phase Shift, \*2: Threshold, \*3: Start Point/End Point, \*4: Exec

## 10.1 Adding, Subtracting, Multiplying, and Dividing Waveforms

### Setting the Upper and Lower Limits of Waveform Display (When Scale Is Set to Manual)

12. Use the **jog shuttle** and **SELECT** to set Upper.
13. Likewise, set Lower.

#### Note

If you select Auto, you cannot set Upper and Lower.

### Setting the Unit

14. Use the **jog shuttle** and **SELECT** to set the Unit using up to four characters according to the procedure given in section 4.2.

### Setting the Label

15. Use the **jog shuttle** and **SELECT** to enter the Label according to the procedure given in section 4.2. For a description of the Label display, see section 8.10, "Setting Waveform Labels."

### Turning ON/OFF the Math Waveform Display

16. Use the **jog shuttle** and **SELECT** to set Display to ON or OFF.

As necessary, set Math2 to Math8 in a similar fashion.

### Executing the Computation

17. Press the **Exec** soft key.

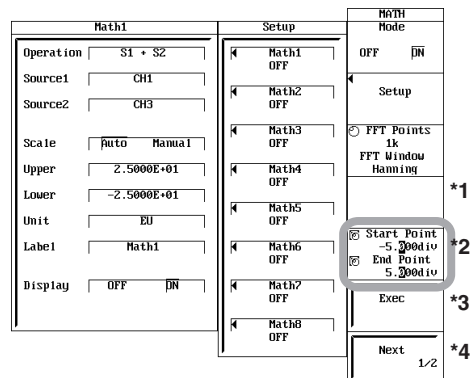

Above is the menu when the user-defined computation option is installed.

The menu on models without the option is as follows:

\*1: Phase Shift, \*2: Threshold, \*3: Start Point/End Point, \*4: Exec

**Explanation**

Addition, subtraction, multiplication, and division can be performed between channels.

**Computation Target Channel**

CH1 to CH16, DSP1 to DSP6 (optional), and Math1 to Math8

**Setting the Computation Range: Start Point/End Point**

By default, the measurement range is  $\pm 5$  divisions of the display frame on the time axis. You can limit this range.

The concept of the computation range is analogous to the concept of the selectable range of cursor display position in cursor measurement.

For details, see section 11.5, "Selectable Range of Cursor Position."

**Setting the Scaling**

Set the upper and lower limits of the math waveform display.

Auto: The upper and lower limits are set according to the computed result.

Manual: The upper and lower limits can be set arbitrarily. The range is from  $-9.9999\text{E}+30$  to  $9.9999\text{E}+30$ .

**Setting the Unit**

Unit can be set arbitrarily using up to four characters. The specified characters are applied to the scale values.

**Linear Scaling**

When performing computation on a channel that has linear scaling set, the computation is performed on the scaled value.

**Notes when Performing Computation**

Computation is not performed again when you change Start Point or End Point while computation is stopped. Be sure to press the Exec soft key to perform the computation again. Otherwise, the waveform will not be displayed correctly when the screen is redrawn.

**Note**

While computation is in execution,  is displayed at the upper left corner of the screen.



# 10.2 Binary Computation

<For a description of this function, refer to page 2-47.>

## Procedure

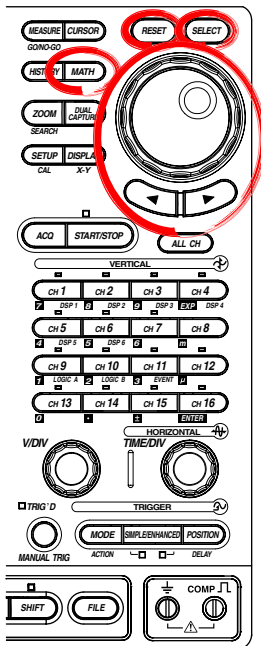

1. Press **MATH**.
2. Press the **Mode** soft key and select ON to display Math waveforms, OFF to not display them. If you select ON, proceed to step 3.

### Setting the Computation Start and End Points

3. Press the **Start Point/End Point** soft key to set the jog shuttle control to Start Point.
4. Turn the **jog shuttle** to set the computation start point.
5. Likewise, set the End Point.

### Setting the Computation

6. Press the **Setup** soft key. The Math1 to Math8 setup dialog boxes appear.
7. Use the **jog shuttle** and **SELECT** to select the Math waveform you wish to set. A MathX setup dialog box opens.

### Setting the Computing Operation

8. Use the **jog shuttle** and **SELECT** to set Operation to Bin(S1).

### Selecting the Channel on Which to Perform Computation

9. Use the **jog shuttle** and **SELECT** to select Source1.

### Setting the Scaling

10. Use the **jog shuttle** and **SELECT** to set Scale to Auto or Manual. If you select Manual, proceed to step 8; if you select Auto, proceed to step 10.

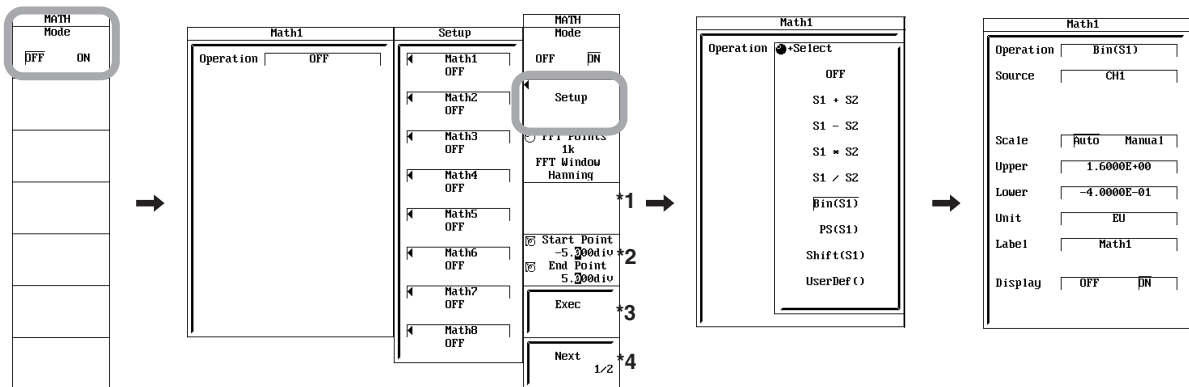

Above is the menu when the user-defined computation option is installed. The menu on models without the option is as follows: \*1: Phase Shift, \*2: Threshold, \*3: Start Point/End Point, \*4: Exec

**Setting the Upper and Lower Limits of Waveform Display**

**(When Scale Is Set to Manual)**

11. Use the **jog shuttle** and **SELECT** to set Upper.
12. Likewise, set Lower.

**Note**

If you select Auto, you cannot set Upper and Lower.

**Setting the Unit**

13. Use the **jog shuttle** and **SELECT** to set the Unit using up to four characters according to the procedure given in section 4.2.

**Setting the Label**

14. Use the **jog shuttle** and **SELECT** to enter the Label according to the procedure given in section 4.2. For a description of the Label display, see section 8.10, "Setting Waveform Labels."

**Turning ON/OFF the Math Waveform Display**

15. Use the **jog shuttle** and **SELECT** to set Display to ON or OFF.

**Setting the Threshold Level**

16. On models with the user-defined computation option, press the **Next 1/2** soft key.
17. Press the **Threshold** soft key.
18. Use the **jog shuttle** and **SELECT** to set the trace (channel on which to assign the threshold level).
19. Use the **jog shuttle** and **SELECT** to set Thr Upper.
20. Likewise, set Thr Lower.

As necessary, set Math2 to Math8 in a similar fashion.

**Executing the Computation**

21. Press the **Exec** soft key.

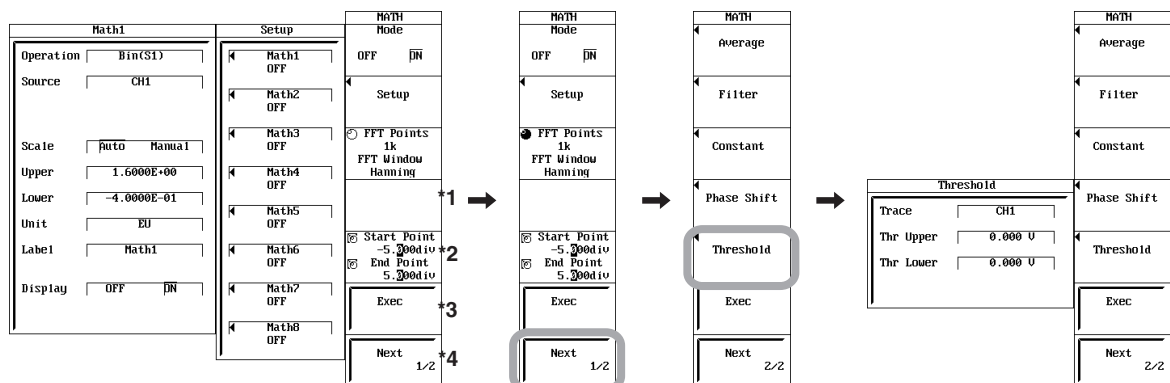

Above is the menu when the user-defined computation option is installed.

The menu on models without the option is as follows: \*1: Phase Shift, \*2: Threshold, \*3: Start Point/End Point, \*4: Exec

### Explanation

This function converts CH1 to CH16 or Math1 to Math7 waveform to a digital signal (1s and 0s) according to the specified threshold level.

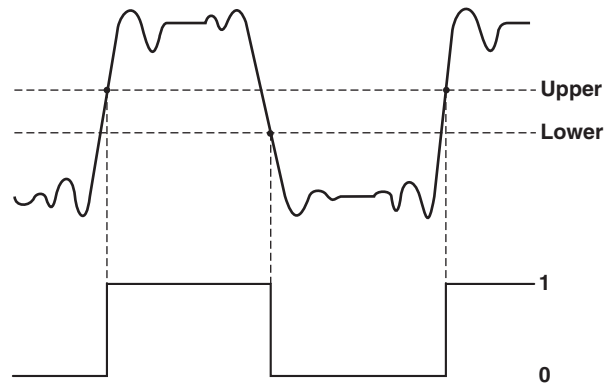

### Setting the Computation Range: Start Point/End Point

By default, the measurement range is  $\pm 5$  divisions of the display frame on the time axis. You can limit this range.

The concept of the computation range is analogous to the concept of the selectable range of cursor display position in cursor measurement.

For details, see section 11.5, "Selectable Range of Cursor Position."

### Setting the Unit

Unit can be set arbitrarily using up to four characters. The specified characters are applied to the scale values.

### Linear Scaling

When performing computation on a channel that has linear scaling set, the computation is performed on the scaled value.

### Notes When Performing Computation

Computation is not performed again when you change Start Point or End Point while computation is stopped. Be sure to press the Exec soft key to perform the computation again. Otherwise, the waveform will not be displayed correctly when the screen is redrawn.

### Note

---

While computation is in execution,  is displayed at the upper left corner of the screen.

---

# 10.3 Performing Power Spectrum Computation (FFT)

<For a description of this function, refer to page 2-47.>

## Procedure

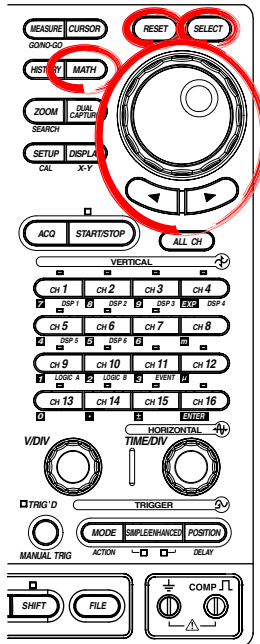

1. Press **MATH**.
2. Press the **Mode** soft key and select ON to display Math waveforms, OFF to not display them. If you select ON, proceed to step 3.

### Setting the Computation Start and End Points

3. Press the **Start Point/End Point** soft key to set the jog shuttle control to Start Point.
4. Turn the **jog shuttle** to set the computation start point.
5. Likewise, set the End Point.

### Setting the Computation

6. Press the **Setup** soft key. The Math1 to Math8 setup dialog boxes appear.
7. Use the **jog shuttle** and **SELECT** to select the Math waveform you wish to set. A MathX setup dialog box opens.

### Setting the Computing Operation

8. Use the **jog shuttle** and **SELECT** to set Operation to PS(S1).

### Selecting the Channel on Which to Perform Computation

9. Use the **jog shuttle** and **SELECT** to select Source.

### Setting the Scaling

10. Use the **jog shuttle** and **SELECT** to set Scale to Auto or Manual. If you select Manual, proceed to step 11; if you select Auto, proceed to step 13.

### Setting the Upper and Lower Limits of Waveform Display (When Scale Is Set to Manual)

11. Use the **jog shuttle** and **SELECT** to set Upper.
12. Likewise, set Lower.

### Note

If you select Auto, you cannot set Upper and Lower.

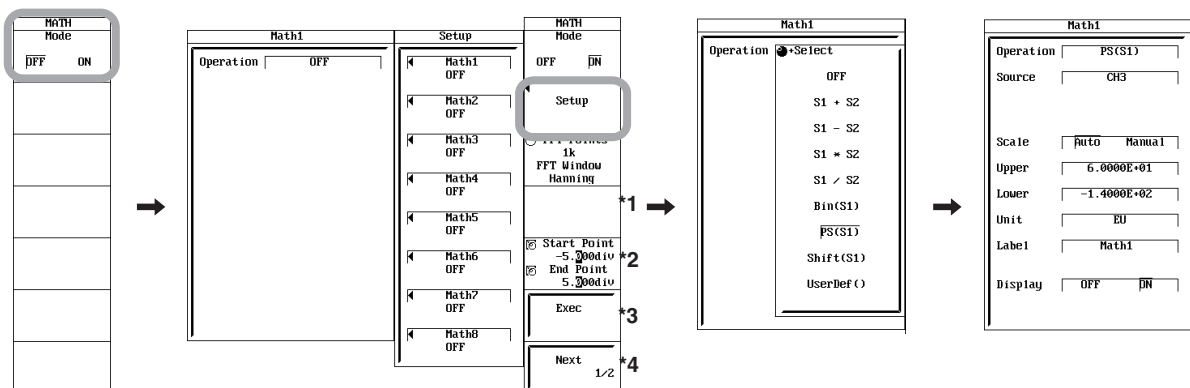

Above is the menu when the user-defined computation option is installed.

The menu on models without the option is as follows: \*1: Phase Shift, \*2: Threshold, \*3: Start Point/End Point, \*4: Exec

## 10.3 Displaying the Power Spectrum

### Setting the Unit

- Use the **jog shuttle** and **SELECT** to set the Unit using up to four characters according to the procedure given in section 4.2.

### Setting the Label

- Use the **jog shuttle** and **SELECT** to enter the Label according to the procedure given in section 4.2. For a description of the Label display, see section 8.10, "Setting Waveform Labels."

### Turning ON/OFF the Math Waveform Display

- Use the **jog shuttle** and **SELECT** to set Display to ON or OFF.

### Setting the Number of FFT Points

- Press the **FFT Points/FFT Window** soft key to set the jog shuttle control to FFT Points.
- Turn the **jog shuttle** to select 1k, 2k, 5k, 10k, 20k, 50k, or 100k.

### Selecting the Time Window

- While the jog shuttle control is set to FFT Points, press the **FFT Points/FFT Window** soft key again. The FFT Window selection menu appears.
- Select the time window from Rect, Hanning, FlatTop, and Exponential. You can select Exponential only when the user-defined computation option is installed.
- If you selected Exponential, press the **Exponential Window Setup** soft key.
- Use the jog shuttle and **SELECT** to set Damping Rate, Force1, and Force2.

As necessary, set Math2 to Math8 in a similar fashion.

### Executing the Computation

- Press the **Exec** soft key.

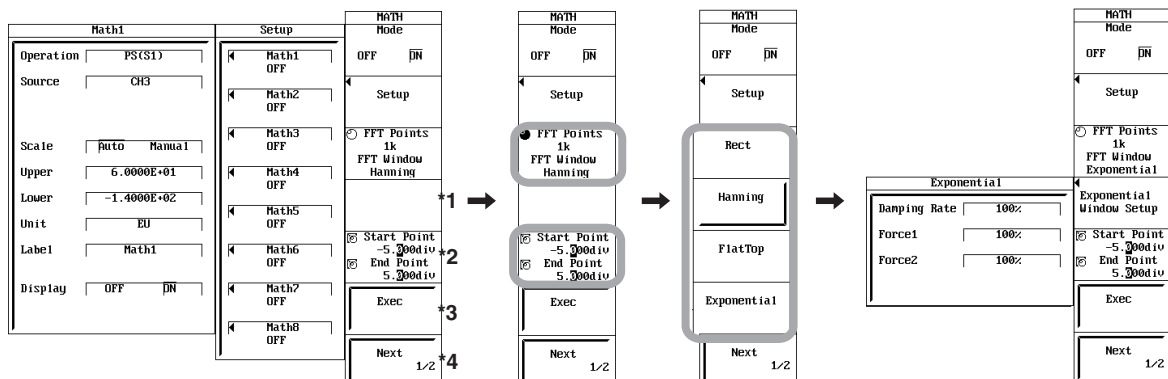

Above is the menu when the user-defined computation option is installed. The menu on models without the option is as follows: \*1: Phase Shift, \*2: Threshold, \*3: Start Point/End Point, \*4: Exec

**Explanation**

This function displays the power spectrum of CH1 to CH16, DSP1 to DSP6 (optional), and Math1 to Math7 waveforms.

**Setting the Computation Range: Start Point/End Point**

By default, the measurement range is  $\pm 5$  divisions of the display frame on the time axis. You can limit this range.

The concept of the computation range is analogous to the concept of the selectable range of cursor display position in cursor measurement.

For details, see section 11.5, "Selectable Range of Cursor Position."

**Number of Computed Points: FFT Point**

Select 1000 (1 k), 2000 (2 k), 5000 (5 k), 10000 (10 k), 20000 (20 k), 50000 (50 k), or 100000 (100 k).

Using the number of computing points from the specified Start point, FFT is performed and the power spectrum is displayed.

**Note**

If you set the number of FFT points to 50k or greater, only Math1 and Math2 can be used. In this case, Math3 to Math8 cannot be used even in computations other than FFT.

Example 1) Math1: C1×C2, Math2: PS-LOGMAG(M1), Math3: C3×C4,  
Math1 to Math3: The number of FFT points is 50k  
→ Computes only Math1 and Math2.

Example 2) Math1: C1, Math2: C2, Math3: The number of FFT points is 50k  
→ Computes only Math1 and Math2.

**Selecting the Time Window**

Select from the following four types.

Rect (Rectangular): Best suited for transient signals that attenuate completely within the time window.

Hanning: Best suited for continuous and non-periodic signals.

Flattop: Best suited for improve the accuracy of the level even if the frequency resolution is to be compromised.

Exponential (window): The exponential window eliminates noise components from the signal. It can be selected only when the user-defined computation option is installed.  
It is effective against frequency response test signals generated through impulse excitation.

### **Damping Rate, Force1, Force 2 (When Window Is Set to Exponential)**

**Damping rate:** Sets the weight of the last data point as a damping rate when taking the weight of the first data point of the FFT computation to be 100% (= 1). Set the value in the range of 1 to 100% (1% resolution). If the damping rate is set to 100%, the window is equivalent to a rectangular window. The setting applies to both the input signal and output (response).

**Force1:** Sets the area over which computation performed in terms of a percentage from the first FFT point when taking the number of FFT points to be 100%. Set the area in the range of 1 to 100% (1% resolution). If the area is set to 100%, the window is equivalent to a rectangular window. The data outside the area is computed as an average value of the area. The setting applies to the input signal (first parameter) of the one-input FFT or two-input FFT.

**Force2:** The setting applies to the output (response) signal (second parameter) of the two-input FFT. The setting is the same as Force1.

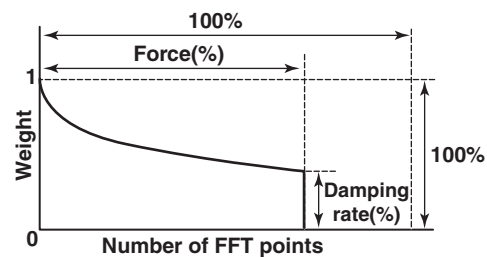

### **Displaying the Overall Value (Only When Measure Is Set to ON)**

If the channels (Math1 to Math8) on which power spectrum computation (PS or PSD\*) is selected are in the middle of the automated measurement of waveform parameters (MEASURE: ON) and Rms is ON, the screen shows "Rms = overall value."

For details on the automated measurement of waveform parameters, see section 11.6.

For details on the overall value, see page App-19.

\* PSD is available only on models with the user-defined computation option (see section 10.5).

### **Note**

If Window is set to Exponential, the overall value is not displayed.

### **Linear Scaling**

When performing computation on a channel that has linear scaling set, the computation is performed on the scaled value.

### **Notes When Displaying Power Spectrums**

- The power spectrum cannot be computed, if the displayed record length is less than number of computation points (Point).
- The number of computed points, time window, Start Point, and End Point are common to all computation channels.
- You cannot expand the FFT waveforms horizontally that would cause the number of points to be 50 or less. In such case, cursor measurement is not possible.

### **Notes When Performing Computation**

- Computation is not performed again when you change Start Point or End Point while computation is stopped. Be sure to press the Exec soft key to perform the computation again. Otherwise, the waveform will not be displayed correctly when the screen is redrawn.
- Normally, computation is performed on the sampled data stored in the acquisition memory. However, for waveforms that have been acquired in envelope mode, computation is performed on the maximum/minimum values per acquisition interval.

### **Note**

While computation is in execution,  is displayed at the upper left corner of the screen.

# 10.4 Phase-Shifted Display

<For a description of this function, refer to page 2-48.>

## Procedure

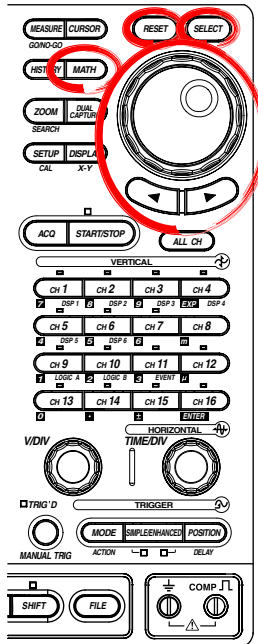

1. Press **MATH**.
2. Press the **Mode** soft key and select ON to display Math waveforms, OFF to not display them. If you select ON, proceed to step 3.

### Setting the Computation Start and End Points

3. Press the **Start Point/End Point** soft key to set the jog shuttle control to Start Point.
4. Turn the **jog shuttle** to set the computation start point.
5. Likewise, set the End Point.

### Setting the Computation

6. Press the **Setup** soft key. The Math1 to Math8 setup dialog boxes appear.
7. Use the **jog shuttle** and **SELECT** to select the Math waveform you wish to set. A MathX setup dialog box opens.

### Setting the Computing Operation

8. Use the **jog shuttle** and **SELECT** to set Operation to Shift(S1).

### Selecting the Channel Whose Phase Is to Be Shifted

9. Use the **jog shuttle** and **SELECT** to select Source1.

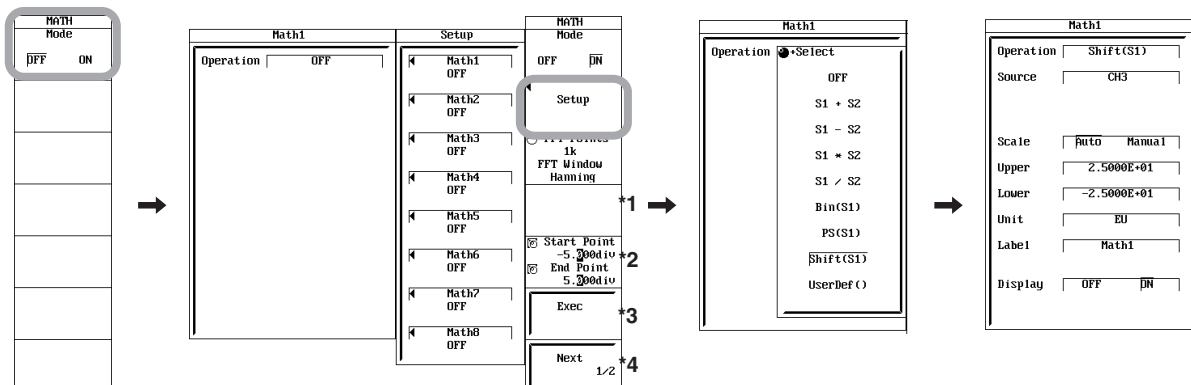

Above is the menu when the user-defined computation option is installed.

The menu on models without the option is as follows:\*1: Phase Shift, \*2: Threshold, \*3: Start Point/End Point, \*4: Exec



**Selecting the Time (or Data Points) for Shifting the Phase**

10. On models with the user-defined computation option, press the **Next 1/2** soft key.
11. Press the **Phase Shift** soft key. A dialog box used to set the phase appears.
12. Use the **jog shuttle** and **SELECT** to set the time or data points for shifting the phase of each waveform. If the time base is set to internal clock (Int), set the time for shifting the phase. If the time base is set to external clock (Ext), set the number of data points for shifting the phase.

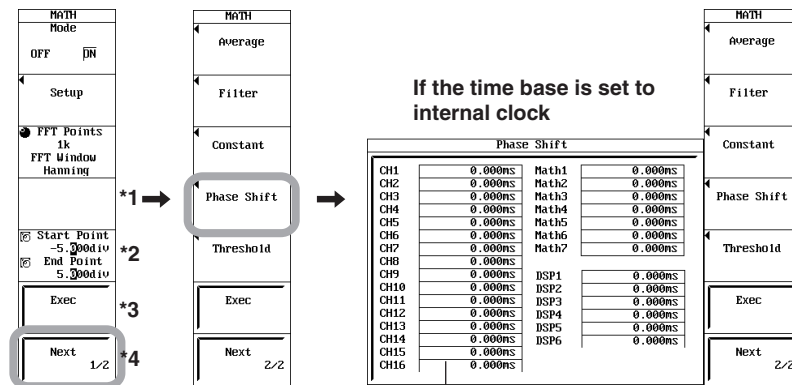

If the time base is set to external clock, the setup menu used to set the number of data points for shifting the phase appears.

Above is the menu when the user-defined computation option is installed. The menu on models without the option is as follows:  
 \*1: Phase Shift, \*2: Threshold, \*3: Start Point/End Point, \*4: Exec

**Turning ON/OFF the Math Waveform Display**

13. Use the **jog shuttle** and **SELECT** to set Display to ON or OFF. As necessary, set Math2 to Math8 in a similar fashion.

**Executing the Computation**

14. Press the **Exec** soft key.

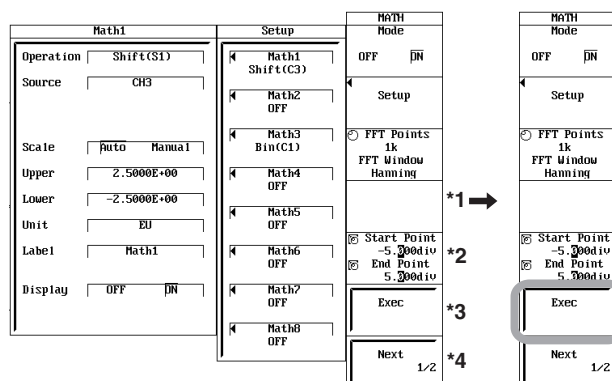

Above is the menu when the user-defined computation option is installed. The menu on models without the option is as follows:  
 \*1: Phase Shift, \*2: Threshold, \*3: Start Point/End Point, \*4: Exec

## Explanation

The phase of CH1 to CH16, DSP1 to DSP6 (optional), and Math1 to Math7 waveforms can be displayed with the phase shifted. Computation can also be performed on phase-shifted waveforms.

### Setting the Computation Range: Start Point/End Point

By default, the measurement range is  $\pm 5$  divisions of the display frame on the time axis. You can limit this range.

The concept of the computation range is analogous to the concept of the selectable range of cursor display position in cursor measurement.

For details, see section 11.5, "Selectable Range of Cursor Position."

### Allowable Shift Range

The phase can be shifted in the following range.

- **When the Time Base Is Set to Internal Clock**

Selectable range: Time value of  $-(\text{record length}/2)$  to  $(\text{record length}/2)$

Resolution: 1/sample rate

The sample rate varies depending on the record length or T/div setting. For details, see appendix 1, "Relationship between the Time Axis Setting, Sample Rate and Record Length."

- **When the Time Base Is Set to External Clock**

Selectable range:  $-(\text{record length}/2)$  to  $(\text{record length}/2)$

Resolution: 1

### When a Waveform That Results by Offsetting the CH1 Waveform by 5 ms Is Set to Math1

- Phase Shift CH1: 5 ms
- Math1 Operation: Shift (S1)  
Source1: CH1

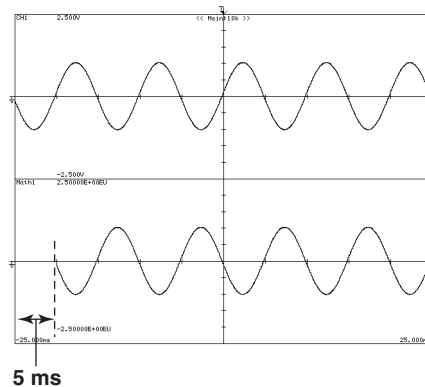

### Linear Scaling

When performing computation on a channel that has linear scaling set, the computation is performed on the scaled value.

### Notes when Performing Computation

Computation is not performed again when you change Start Point or End Point while computation is stopped. Be sure to press the Exec soft key to perform the computation again. Otherwise, the waveform will not be displayed correctly when the screen is redrawn.

### Note

While computation is in execution,  is displayed at the upper left corner of the screen.

# 10.5 User-Defined Computation (Optional)

<For a description of this function, refer to page 2-48.>

## Procedure

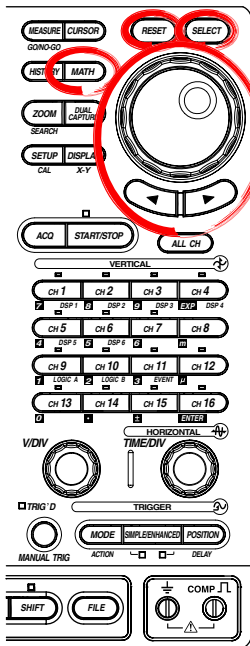

1. Press **MATH**.
2. Press the **Mode** soft key and select ON to display Math waveforms, OFF to not display them. If you select ON, proceed to step 3.

### Setting the Computation Start and End Points

3. Press the **Start Point/End Point** soft key to set the jog shuttle control to Start Point.
4. Turn the **jog shuttle** to set the computation start point.
5. Likewise, set the End Point.

### Setting the Computation

6. Press the **Setup** soft key. The Math1 to Math8 setup dialog boxes appear.
7. Use the **jog shuttle** and **SELECT** to select the Math waveform you wish to set. A MathX setup dialog box opens.

### Setting the Computing Operation

8. Use the **jog shuttle** and **SELECT** to set Operation to UserDef( ).

### User-Defined Equation

9. Use the **jog shuttle** and **SELECT** to select UserDef( ). A menu for setting the equation appears.
10. Enter the equation using up to 55 characters according to the procedure given in section 4.2. The head section (19 characters) of the entered equation is displayed in the Expression box.

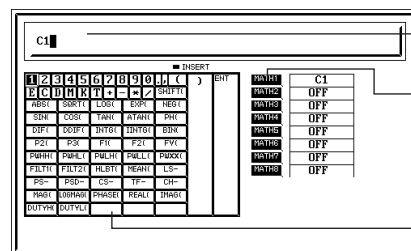
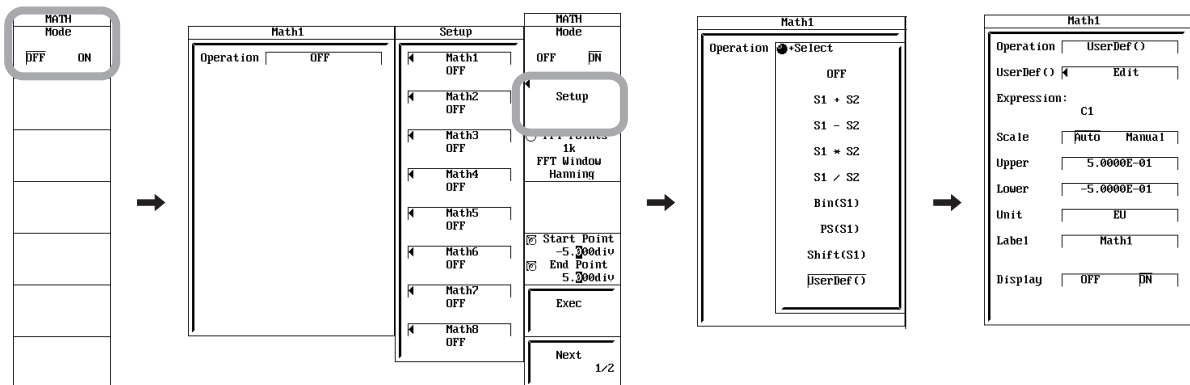

The contents entered from the soft keyboard are displayed.

Select Math1 to Math8 and press **SELECT** to enter the equation displayed on the right side.

Use the jog shuttle and arrow keys to select the desired operator. To confirm, select **ENT**.

**Setting the Scaling**

11. Use the **jog shuttle** and **SELECT** to set Scale to Auto or Manual.  
If you select Manual, proceed to step 12; if you select Auto, proceed to step 14.

**Setting the Upper and Lower Limits of Waveform Display**

**(When Scale Is Set to Manual)**

12. Use the **jog shuttle** and **SELECT** to set Upper.
13. Likewise, set Lower.

**Note**

If you select Auto, you cannot set Upper and Lower.

**Setting the Unit**

14. Use the **jog shuttle** and **SELECT** to set the Unit using up to four characters according to the procedure given in section 4.2.

**Setting the Label**

15. Use the **jog shuttle** and **SELECT** to enter the Label according to the procedure given in section 4.2. For a description of the Label display, see section 8.10, "Setting Waveform Labels."

**Turning ON/OFF the Math Waveform Display**

16. Use the **jog shuttle** and **SELECT** to set Display to ON or OFF.

As necessary, set Math2 to Math8 in a similar fashion.

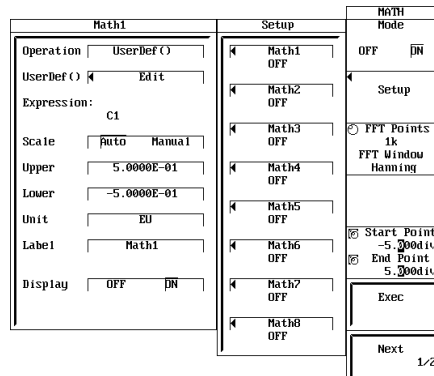

**Setting the Threshold Level**

17. Press the **Next 1/2** soft key.
18. Press the **Threshold** soft key.
19. Use the **jog shuttle** and **SELECT** to set the trace (channel on which to assign the threshold level).
20. Use the **jog shuttle** and **SELECT** to set Thr Upper.
21. Likewise, set Thr Lower.

As necessary, set Math1 to Math8 in a similar fashion.

**Setting the Digital Filter**

If you specified FILT1 or FILT2 in the equation, set the digital filter.

22. Press the **Filter** soft key. The filter setup dialog box appears.
23. Use the **jog shuttle** and **SELECT** to set Filter Select to FILT1 or FILT2.
24. Use the **jog shuttle** and **SELECT** to select Filter Type from Gauss, Sharp, and IIR.
25. Press the **Filter Band** soft key to select Low-Pass, High-Pass, or Band-Pass.
26. Use the **jog shuttle** and **SELECT** to set CutOff.

If you set Filter Band to Band-Pass, set CutOff1/CutOff2 (cutoff frequencies for both high and low).

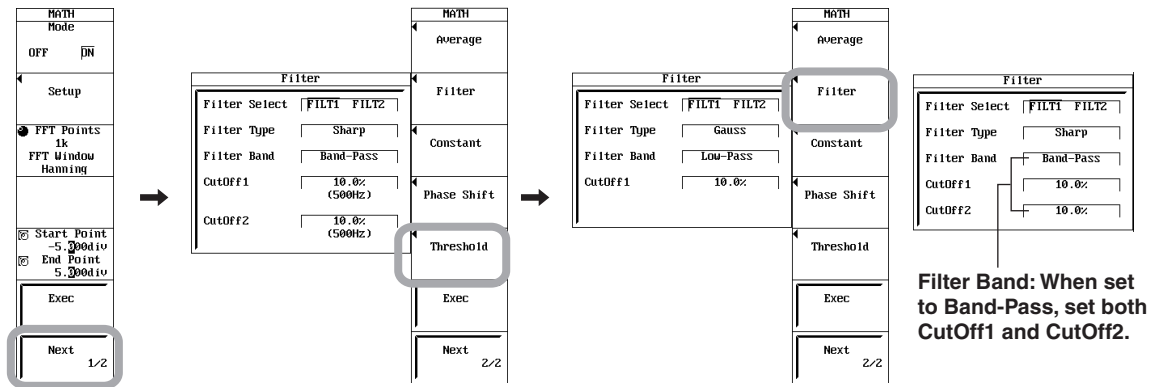

**Setting the Number of Points for FFT and the Time Window**

If you specified FFT in the equation, set the following items.

- 27. Set FFT Points and FFT Window according to steps 19 to 22 in section 10.3.

**Setting the Constants (K1 to K8)**

- 28. Press the **Next 1/2** soft key.
- 29. Press the **Constant** soft key. The constant setup menu appears.
- 30. Use the **jog shuttle** and **SELECT** to set the constants K1 to K8.

**Setting Average and Peak Computation**

- 31. Press the **Average** soft key. The average setup dialog box appears.
- 32. Use the **jog shuttle** and **SELECT** to select Average Mode from OFF, Linear, Exp, Cycle, and Peak. If you select Peak, the operation ends here.

- **When Linear or Exp Is Selected**

- 33. Use the **jog shuttle** and **SELECT** to set Average Domain to Time or Freq.
- 34. Use the **jog shuttle** and **SELECT** to set Linear Count (average count) or Average Weight (attenuation).

- **When Cycle Is Selected**

- 35. Use the **jog shuttle** and **SELECT** to set Cycle Count (the number of data points per cycle).

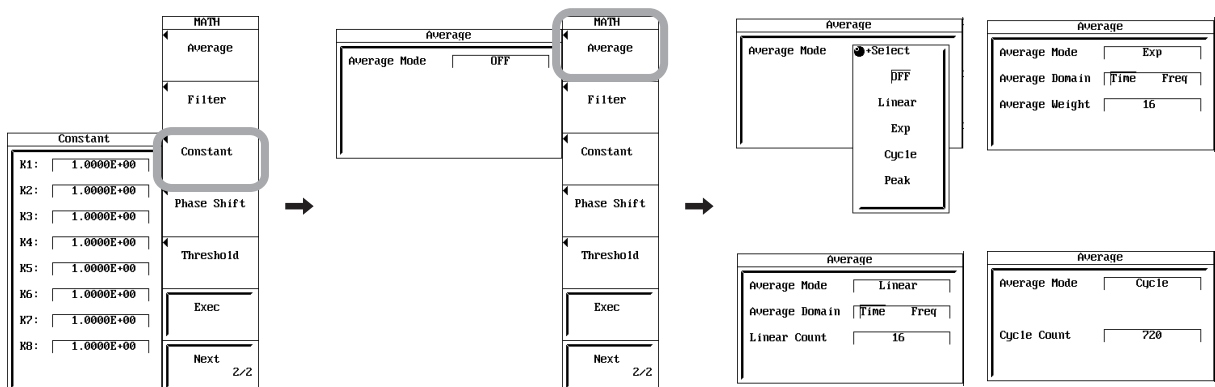

**Setting the Phase Offset of Shift Computation**

If you specified SHIFT in the equation, set the amount of phase shift.

- 36. Press the **Phase shift** soft key.
- The phase shift setup dialog box appears.
- 37. Use the **jog shuttle** and **SELECT** to set the time or data points for shifting the phase of each waveform. If the time base is set to internal clock (Int), set the time for shifting the phase. If the time base is set to external clock (Ext), set the number of data points for shifting the phase.

**Executing the Computation**

- 38. Press the **Exec** soft key.

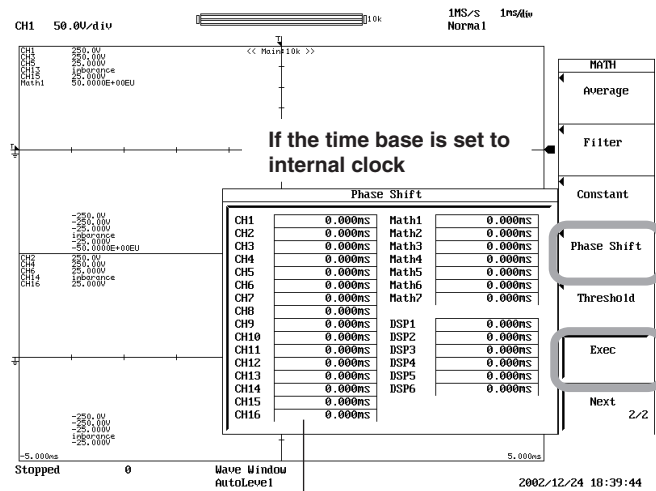

If the time base is set to external clock, the setup menu used to set the number of data points for shifting the phase appears.

DSP1 to DSP6 are optional.

**Explanation**

The following operators can be combined to make computations.

**Available Operators**

Operator	Setting Example	Description
+, -, *, /	C1+C2	Displays the four arithmetical operations of the two specified waveform.
SHIFT	SHIFT(C1)	Displays the specified waveform with the phase shifted.
ABS	ABS(M1)	Displays the absolute value of the specified waveform.
SQRT	SQRT(C2)	Displays the square root of the specified waveform.
LOG	LOG(C1)	Displays the logarithm of the specified waveform.
EXP	EXP(C1)	Display the exponent of the specified waveform.
NEG	NEG(C1)	Displays the specified waveform inverted around 0.
SIN	SIN(T)	Displays the sine of the specified waveform.
COS	COS(C1)	Displays the cosine of the specified waveform.
TAN	TAN(C1)	Displays the tangent of the specified waveform.
ATAN	ATAN(C1,C2)	Displays the arc tangent of the two specified waveforms (a value within $\pm\pi$ ).
PH	PH(C1,C2)	Displays the phase difference between the two specified waveforms.
DIF	DIF(C1)	Displays the derivative of the specified waveform.
DDIF	DDIF(C1)	Displays the 2nd order derivative of the specified waveform.
INTG	INTG(C1)	Displays the integral of the specified waveform.
IINTEG	IINTEG(C1)	Displays the double integral of the specified waveform.
BIN	BIN(C1)	Displays the binary computation of the waveform.
P2	P2(C1)	Displays the square of the specified waveform.
P3	P3(C1)	Displays the cube of the specified waveform.
F1	F1(C1,C2)	Displays the $\sqrt{C1^2 + C2^2}$ of the specified waveform.
F2	F2(C1,C2)	Displays the $\sqrt{C1^2 - C2^2}$ of the specified waveform.
FV	FV(C1)	Displays the inverse of the PWHH of the pulse width.
PWHH	PWHH(M1)	Displays the pulse width computation from the rising edge to the next rising edge.
PWHL	PWHL(C2)	Displays the pulse width computation from the rising edge to the next falling edge.
PWLH	PWLH(C1)	Displays the pulse width computation from the falling edge to the next rising edge.
PWLL	PWLL(C1)	Displays the pulse width computation from the falling edge to the next falling edge.
PWXX	PWXX(C2)	Displays the pulse width computation from the rising or falling edge to the next rising or falling edge.
DUTYH	DUTYH(C1)	Positive (high) duty cycle within each cycle of the specified waveform
DUTHL	DUTYL(C1)	Negative (low) duty cycle within each cycle of the specified waveform
FILT1	FILT1(C1)	Displays the specified filter after applying a filter.
FILT2	FILT2(C1)	Displays the specified filter after applying a filter.
HLBT	HLBT(C1)	Displays the Hilbert's transform of the specified waveform.
MEAN	MEAN(C1)	Displays the moving average of the 10th order of the specified waveform.
LS-	LS-MAG(C1)	Displays the amplitude of the specified waveform's linear spectrum.
	LS-LOGMAG(C1)	Displays the logarithmic amplitude of the specified waveform's linear spectrum.
	LS-PHASE(C1)	Displays the phase of the specified waveform's linear spectrum.
	LS-REAL(C1)	Displays the real part of the specified waveform's linear spectrum.
	LS-IMAG(C1)	Displays the imaginary part of the specified waveform's linear spectrum.
PS-	PS-MAG(C1)	Displays the amplitude of the specified waveform's power spectrum.
	PS-LOGMAG(C1)	Displays the logarithmic amplitude of the specified waveform's power spectrum.



## 10.5 User-Defined Computation (Optional)

Operator	Setting Example	Description
PSD-	PSD-MAG(C1)	Displays the amplitude of the specified waveform's power spectrum density.
	PSD-LOGMAG(C1)	Displays the logarithmic amplitude of the specified waveform's power spectrum density.
CS-	CS-MAG(C1,C2)	Displays the amplitude of the two specified waveforms' cross spectrum.
	CS-LOGMAG(C1,C2)	Displays the logarithmic amplitude of the two specified waveforms' cross spectrum.
	CS-PHASE(C1,C2)	Displays the phase of the two specified waveforms' cross spectrum.
	CS-REAL(C1,C2)	Displays the real part of the two specified waveforms' cross spectrum.
	CS-IMAG(C1,C2)	Displays the imaginary part of the two specified waveforms' cross spectrum.
TF-	TF-MAG(C1,C2)	Displays the amplitude of the two specified waveforms' transfer function.
	TF-LOGMAG(C1,C2)	Displays the logarithmic amplitude of the two specified waveforms' transfer function.
	TF-PHASE(C1,C2)	Displays the phase of the two specified waveforms' transfer function.
	TF-REAL(C1,C2)	Displays the real part of the two specified waveforms' transfer function.
	TF-IMAG(C1,C2)	Displays the imaginary part of the two specified waveforms' transfer function.
CH-	CH-MAG(C1,C2)	Displays the amplitude of the two specified waveforms' coherence function

### Waveforms and Variables to Be Computed

CH waveforms (C1 to C16), DSP channel waveform (DSP1 to DSP, optional), Math waveform (M1 to M7), variable T (the total number of data points in the time direction is defined to be T. It is displayed as a rising line on the screen.)

### Combinations of Computing Equations That Are Not Allowed

- An equation of a large number cannot be placed in an equation of a smaller number.  
Example: Math5 = M6+M3
- Computation containing only constants (K1 to K8) are not allowed.  
Example: Math5 = M1+K8
- Only two operators can be used in an equation for FILT1 and FILT2.  
Example: FILT1(C1)+FILT1(C2)+FILT1(C3)
- Only one operator can be used in a FFT equation.  
Example: PS-MAG(C1+C2)
- Other computations cannot be performed on the result of the FFT.  
Example: PS-MAG(C1)+C2
- Other computations cannot be performed on the pulse width computation.  
Example: PWHH(C1)+C2
- Only one operator can be used in an equation when making a Shift width computation, pulse width computation, or binary computation.  
Example: SHIFT(C1+C2), BIN(C1-C2), PWHH(C1\*C1)
- The following computations cannot be performed on DSP channels.  
BIN, PWHH, PWHL, PWLH, PWLL, and PWXX

If you wish to perform an FFT, SHIFT, pulse width computation, or binary computation on the computed result such as C1+C2, enter the equations as in M1=C1+C2, M2=PS-MAG(M1).

**Measurement Range: Start Point/End Point**

Computation is performed on up to 800 kW of data when there is one equation, up to 400 kW when there are two equations, up to 200 kW when there is three or four equations, and up to 100 kW when there are five to eight equations.

By default, the measurement range is  $\pm 5$  divisions of the display frame on the time axis. You can limit this range.

The concept of the computation range is analogous to the concept of the selectable range of cursor display position in cursor measurement.

For details, see section 11.5, "Selectable Range of Cursor Position."

**Setting the Digital Filter**

The following three types of filters are available.

Type	Bandwidth
Gaussian	LowPass
Sharp	LowPass/BandPass/HighPass
IIR (Butterworth)	LowPass/BandPass/HighPass

Selectable range of cutoff frequencies: 2.0% to 30.0% of the sample rate (in 0.2% steps)

**Setting Average and Peak Computation**

Averaging and peak computation can be performed on the computed data. Four types of operations are available: linear, exponential, cycle, and peak.

For linear averaging, set the average count (acquisition count, 2 to 128, in  $2^n$  steps). For exponential averaging, set the attenuation constant (2 to 256, in  $2^n$  steps).

Make sure to specify which waveform, time axis waveform or frequency waveform, to take the average. Specifying a wrong waveform will give a meaningless result.

For cycle averaging, set the number of data points of one cycle (Cycle Count) in the range, 10 to 1800. This number is applied to the data from the start to the end of the computed data, but the remaining data that cannot be divided by the Cycle Count are ignored. Cycle average cannot be performed on an FFT waveform.

For peak computation, the maximum value at each point of the computed data is determined and the waveform is displayed. For each computation, the new computed value is compared with the past value and the larger value is kept.

- **Example of Cycle Averaging**

When the record length is 10 k, the Cycle Count is 720, the start point of computation is  $-5.000$  divisions, and the end point is  $+5.000$  divisions

$10k/720 = 13.88$  13 cycles will be averaged.

$13 \times 720 = 9360$  Data between the start point to the 9360<sup>th</sup> point will be cycle averaged.

- **Notes When Computing Average and Peak Computation**

- Normally auto scaling is defined for the 1st computed waveform. If you wish to obtain a computed waveform whose amplitude varies significantly after averaging (e.g. Coherent function), use manual scaling.
- If averaging is performed, the computation is not performed again after the measurement is stopped. However, if the number of data points for the cycle average is changed, computation is performed again.
- If the averaged waveform is measured using auto scaling and you change to manual scaling after the measurement is stopped, the new setting is not applied. The new setting is applied from the next measurement.
- Averaging cannot be performed on pulse width computation.
- If the computation condition is changed while averaging is in progress, the computed data is cleared at that point, and averaging starts over.

## 10.5 User-Defined Computation (Optional)

---

### **Setting Constants**

The selectable range is from  $-9.9999E+30$  to  $9.9999E+30$ .

### **Setting the Threshold Level of Binary Computation**

With binary computation, the specified waveform (CH1 to CH16, Math1 to Math7) is converted to a digital waveform of 0 and 1 with respect to the threshold level (Upper, Lower).

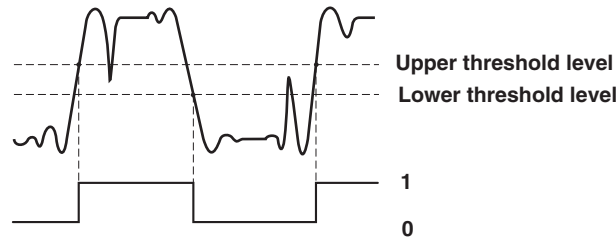

The selectable range for the threshold level varies depending on the specified waveform as shown below.

CH waveforms: 10 divisions within the display screen (resolution is (V/div setting)/100 when observing voltage and  $0.1^{\circ}\text{C}$  when observing temperature).

Math1 waveform: 10 divisions within the screen (resolution is 0.01 division).

### **Setting the FFT: FFT Points/FFT Window**

For a description of the FFT, refer to points, FFT frequency band, and window in Section 10.3, "Performing Power Spectrum Computation (FFT)."

For details on digital filters and the FFT, refer to Appendix 5.

### **Phase Shift**

The phase of a specified waveform is shifted. The amount of shift is specified in the phase shift setup menu.

The selectable range is  $\text{Time/div} \times 5$  (the resolution is  $1/(\text{sample rate})$ ).

### **Linear Scaling**

When performing computation on a channel that has linear scaling set, the computation is performed on the scaled value.

### **Notes When Performing Computation**

Computation is not performed again when you change Start Point or End Point while computation is stopped. Be sure to press the Exec soft key to perform the computation again. Otherwise, the waveform will not be displayed correctly when the screen is redrawn.

### **Note**

While computation is in execution,  is displayed at the upper left corner of the screen.

---

# 11.1 Displaying History Waveforms

<For a description of this function, refer to page 2-53.>

## Procedure

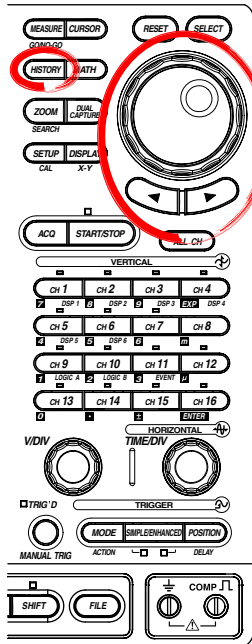

### Recalling Data from the History Memory

1. Press **HISTORY**.
2. Press the **Select Record** soft key.
3. Turn the **jog shuttle** to set the record No. you wish to recall. Set the record No. in the range of Start Record to End Record.
4. Press the **Display Mode** soft key to select One.

### Data Accumulation Display

5. Press the **Start Record/End Record** soft key to set the jog shuttle control to Start Record.
  6. Turn the **jog shuttle** to set the first record No. to be accumulated.
  7. Likewise, set the last record No. (End Record) to be accumulated.
  8. Press the **Display Mode** soft key to select All.
- The data of record numbers specified in steps 5 to 7 are displayed accumulated. To abort the accumulated display, press the **Display Mode** soft key to select One.

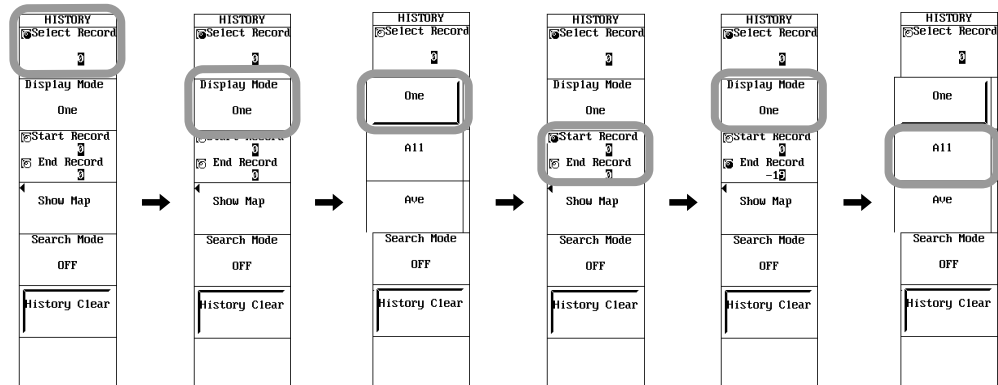

## 11.1 Displaying History Waveforms

### Average Display of Data

9. Press the **Start Record/End Record** soft key to set the jog shuttle control to Start Record.
10. Turn the **jog shuttle** to set the first record No. to be averaged.
11. Likewise, set the last record No. (End Record) to be averaged.
12. Press the **Display Mode** soft key to select Ave.  
The data of record numbers specified in steps 5 to 7 are displayed averaged.  
To abort the average display, press the **Display Mode** soft key to select One.

### Displaying a List of Time Stamps

13. Press the **Show Map** soft key. A list of acquired data numbers and the time at acquisition end are displayed.
14. Turn the **jog shuttle** to select the data you wish to display and press **SELECT**.

### Clearing the History Memory

15. Press the **History Clear** soft key. All the waveforms in the acquisition memory are cleared.

### Note

Waveform acquisition cannot be started when the HISTORY menu is displayed.

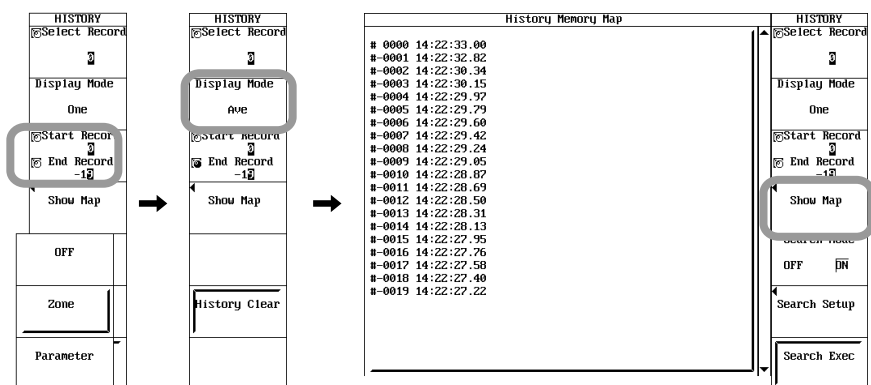

**Explanation**

The acquisition memory retains waveform data of the last specified number of triggers. If a trigger is activated beyond the number of triggers that can be held, the oldest waveform data is cleared.

**Selected Record No.**

The selectable range is 0 to –(the number of retained waveforms – 1). The default value is 0. The newest (current) waveform is 0, the waveform previous to that is –1, and so on. The number of triggers that can be held varies depending on the selected record length. For details, see appendix 2.

If the trigger count is 1, only the displayed waveform is held in the acquisition memory; waveform data in the past are not held.

**Display Mode**

- **Display Only the Selected Waveform: One**  
Select the waveform to be displayed using Select Record in the range specified by Start Record and End Record.
- **Display All Waveforms in the Selected Range: All**  
The waveform data specified by Start Record and End Record are displayed accumulated. The waveform data selected by Select Record is displayed brightly.
- **Average Display: Ave**  
The waveform data specified by Start Record and End Record are displayed averaged.

**Show Map (A List of Time Stamps)**

You can list the number of the waveform data stored in the acquisition memory and the time at acquisition end. One screen displays 75 data points of information. You can scroll through the data by using the jog shuttle.

**Clearing the History Memory**

- Clears all the waveforms in the acquisition memory.
- Cleared waveforms cannot be recovered.

**Notes When Setting the History Memory Function**

- You cannot use the history memory function when the dual capture function is used or when realtime recording is in progress.
- You cannot use the history memory function, if the acquisition mode is Average.
- If you abort the waveform acquisition, the triggered waveform is displayed as a valid waveform.
- History records are not lost when waveform acquisition is stopped and then restarted, provided that acquisition conditions remain unchanged.
- If you change the acquisition settings, history memory is cleared when you restart acquisition using the new settings.  
For details on the waveform acquisition conditions, see section 7.1, “Starting/Stopping Waveform Acquisition.”
- Average display is not possible on the following waveforms.
  - Waveforms when the record length is greater than equal to 1 MW on the standard model, 2.5 MW on the M1 option model, 5 MW on the M2 option model, or 10 MW on the M3 option model.

### Notes When Recalling Data Using the History Memory Function

- You cannot use the history memory function while waveform acquisition is in progress.
- You cannot restart the waveform acquisition when the history memory menu is displayed.
- Settings are restricted by the following condition:  $\text{End Record} \leq \text{Select Record} \leq \text{Start Record}$ .
- If you load a waveform record from the external storage medium, the loaded waveform becomes Record 0. In the case of multiple records (sequential store), the records will be loaded sequentially, with the newest record as 0.
- Computation and automated measurement of waveform parameters are performed on the record No. specified by Select Record. Analysis of old data is possible as long as the history memory content remains unchanged after acquisition is restarted. However, for average display, computation is not performed again when you specify a different record.
- The time displayed in Show Map is the waveform trigger time. The information varies depending on the trigger mode as follows:

Trigger Mode	Condition	Time Displayed in Show Map
Auto/Auto Level	Roll mode	Stop time
Single	Roll mode, trigger not activated	Stop time
Log		Start time

- When displaying all waveforms, if the selected number of records is large, it may take an extended period for the display to complete. In this case,  is indicated at the upper left corner of the screen. To abort the operation, set Display Mode to One.
- Turning OFF the power clears the contents of the history memory. However, if the acquisition memory backup is enabled, the contents of the history memory are backed up.  
For details on the acquisition memory backup function, see section 7.10.

# 11.2 Searching History Memory Data Using Zones (History Search Function)

<For a description of this function, refer to page 2-53.>

## Procedure

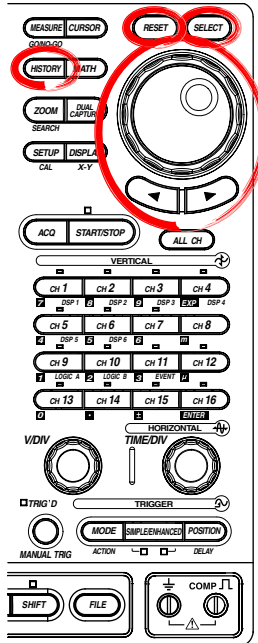

1. Press **HISTORY**.
2. Press the **Search Mode** soft key. The search mode menu appears.
3. Press the **Zone** soft key.

### Setting the Search Zone

4. Press the **Search Setup** soft key. The search setup menu appears.
5. Press the **Select Zone** soft key. The search condition selection menu appears.
6. Press any of the **Zone1** to **Zone4** soft keys to select the search condition.

### Setting the Search Condition

7. Press the **Condition** soft key to select OFF, IN, or OUT.  
If you select IN or OUT, a search window appears in the area where the Source channel is displayed.

### Setting the Source Channel

8. Press the **Source** soft key. The source channel selection menu appears.
9. Press the soft key corresponding to the desired channel to select the source channel.

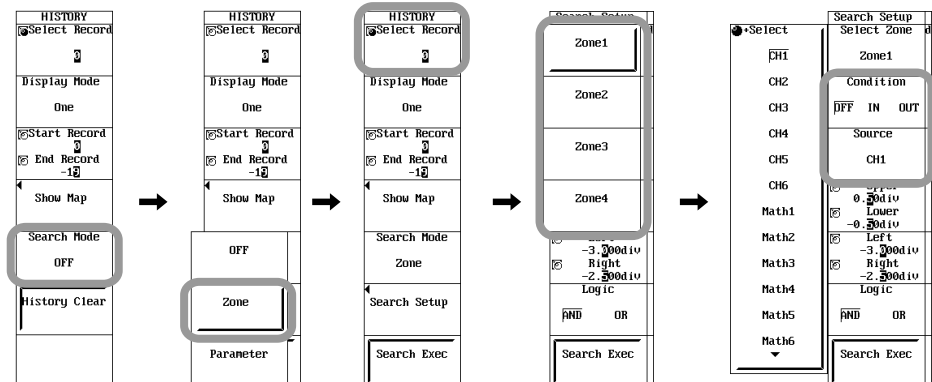



## 11.2 Searching History Memory Data Using Zones (History Search Function)

### Setting the Search Window

10. Press the **Upper/Lower** soft key to set the jog shuttle control to Upper.
11. Turn the **jog shuttle** to set the top of the search range. Pressing **RESET** resets the value to default.
12. Press the **Upper/Lower** soft key to set the jog shuttle control to Lower.
13. Turn the **jog shuttle** to set the bottom of the search range. Pressing **RESET** resets the value to default.  
By controlling both Upper and Lower using the **jog shuttle**, you can move the search window up and down without changing the vertical width.
14. Likewise, use the **Left/Right** soft key to set the horizontal range of the search window.
15. Repeat steps 5 to 13 to set Zone1 to Zone4.

### Setting the Search Logic

16. Press the **Logic** soft key to select AND or OR.

### Executing the Search

17. Pressing the **Search Exec** soft key to execute the search.  
While search is in execution,  is displayed at the upper left corner of the screen.

### Displaying the Waveform That Are Found

18. Press the **ESC** to return to the HISTORY menu.
19. Press the **Show Map** soft key. A list of acquired data numbers and the time at acquisition end are displayed.
20. Turn the **jog shuttle** to select the data you wish to display and press **SELECT**.

### Resetting the Search Results

21. Turn OFF the Search Mode in the HISTORY menu or turn OFF Zone1 to Zone4 and execute the search to reset the search results.

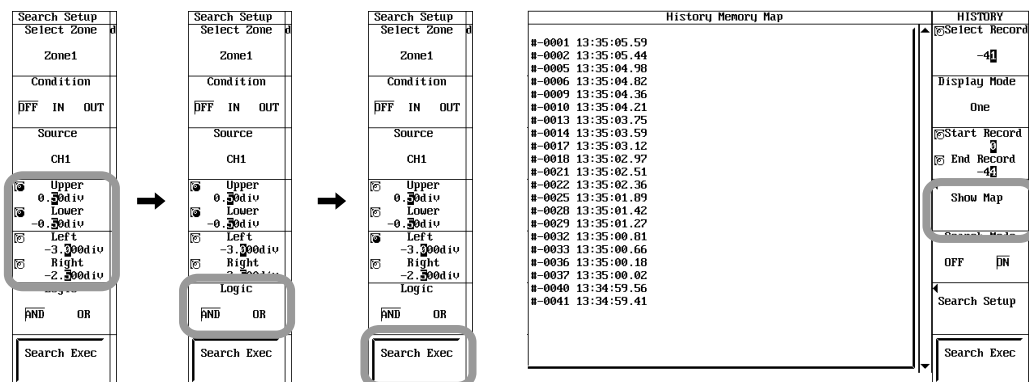

### Explanation

You can search for a waveform that matches the specified conditions from the past waveforms in the acquisition memory and display it.

#### Select Zone

Four types of search zones can be registered in Zone1 to Zone4. You can set the channel that is to be searched, the search condition, and the search range for each search zone.

#### Condition

IN: Searches for waveforms that pass through the specified search window.

OUT: Searches for waveforms that do not pass through the specified window.

OFF: Does not search for waveforms.

#### Source

Search is carried out on the channel that is specified as the Source. The channels that can be specified are CH1 to CH16 and DSP1 to DSP6 (optional). Waveforms of other channels are also displayed.

#### Vertical Range of Search Window: Upper/Lower

The selectable range is  $\pm 5$  divisions. The resolution is 0.01 divisions.

Upper must always be greater than or equal to Lower.

#### Horizontal Range of Search Window: Left/Right

The selectable range is  $\pm 5$  divisions. The resolution is (10 division/display record length).

Right must always be greater than or equal to Left.

#### Logic

AND: Searches for waveforms that meet all search conditions from Zone1 to Zone4.

OR: Searches for waveforms that meet any one of the search conditions from Zone1 to Zone4.

#### Search Range of History Memory Data

The search range is between the Start Rec and the End Rec.

#### Search Order

The search is carried out from the newest waveform to the oldest waveform.

#### Show Map (A List of Time Stamps)

Only the waveforms that are found are listed in Show Map. If the Search Mode is turned OFF, all waveforms are displayed.

# 11.3 Searching History Memory Data Using Parameters (History Search Function)

<For a description of this function, refer to page 2-53.>

## Procedure

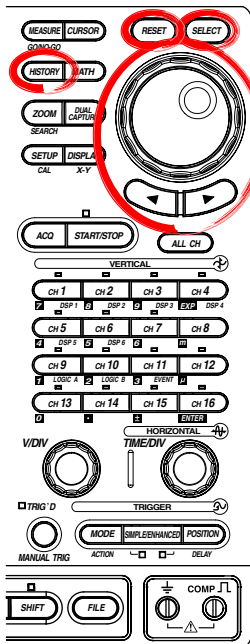

1. Press **HISTORY**.
2. Press the **Search Mode** soft key. The search mode menu appears.
3. Press the **Parameter** soft key.

### Setting the Search Zone

4. Press the **Search Setup** soft key. The search setup menu appears.
5. Press the **Select Param** soft key. The search condition selection menu appears.
6. Press any of the **Param1** to **Param4** soft keys to select the search condition.

### Setting the Search Condition

7. Press the **Condition** soft key to select OFF, IN, or OUT.

### Setting the Source Channel

8. Press the **Item Setup** soft key. The parameter selection menu appears.
9. Use the **jog shuttle** and **SELECT** to select the trace channel.
10. Use the **jog shuttle** and **SELECT** to select the parameter.

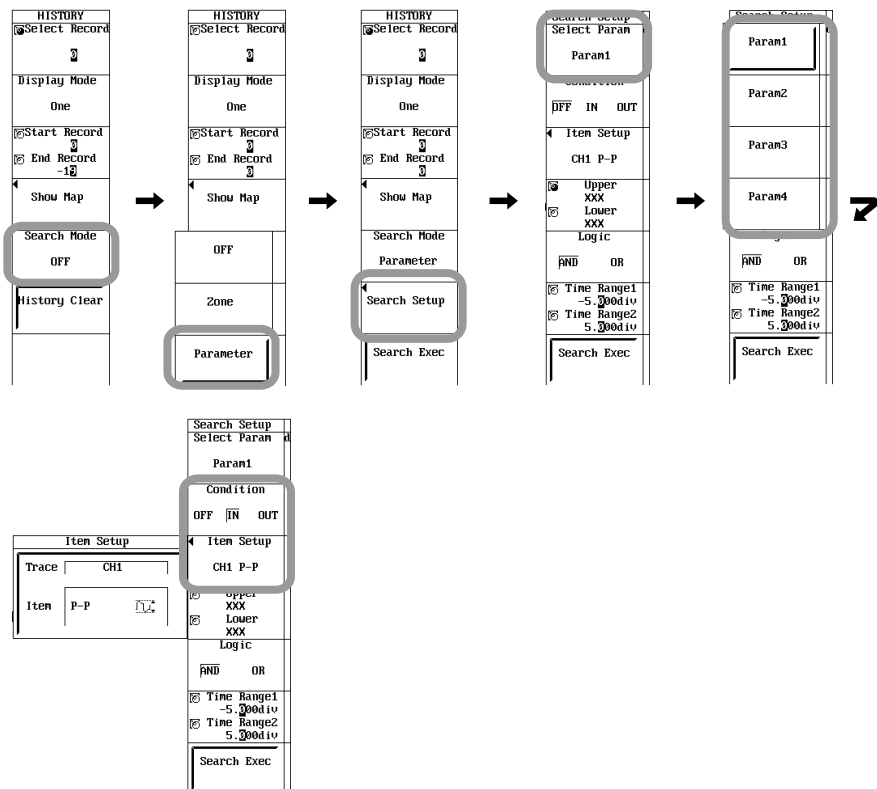

## 11.3 Searching History Memory Data Using Parameters (History Search Function)

### Setting the Condition Range

11. Press the **Upper/Lower** soft key to set the jog shuttle control to Upper.
12. Turn the **jog shuttle** to set the top of the search range. Pressing **RESET** resets the value to default.
13. Press the **Upper/Lower** soft key to set the jog shuttle control to Lower.
14. Turn the **jog shuttle** to set the bottom of the search range. Pressing **RESET** resets the value to default.
15. Repeat steps 4 to 14 to set Param1 to Param4.

### Setting the Search Logic

16. Press the **Logic** soft key to select AND or OR.

### Setting the Parameter Measuring Range

17. Press the **Time Range1/Time Range2** soft key to set the jog shuttle control to Time Range1.
18. Turn the **jog shuttle** to set the left edge of the measuring range. Pressing **RESET** resets the value to default.
19. Press the **Time Range1/Time Range2** soft key to set the jog shuttle control to Time Range2.
20. Turn the **jog shuttle** to set the right edge of the measuring range. Pressing **RESET** resets the value to default.

### Executing the Search

21. Pressing the **Search Exec** soft key to execute the search.  
While search is in execution,  is displayed at the upper left corner of the screen.

### Displaying the Waveform That Are Found

22. Press the **ESC** to return to the HISTORY menu.
23. Press the **Show Map** soft key. A list of acquired data numbers and the time at acquisition end are displayed.
24. Turn the **jog shuttle** to select the data you wish to display and press **SELECT**.

### Resetting the Search Results

25. Turn OFF the Search Mode in the HISTORY menu or turn OFF Param1 to Param4 and execute the search to reset the search results.

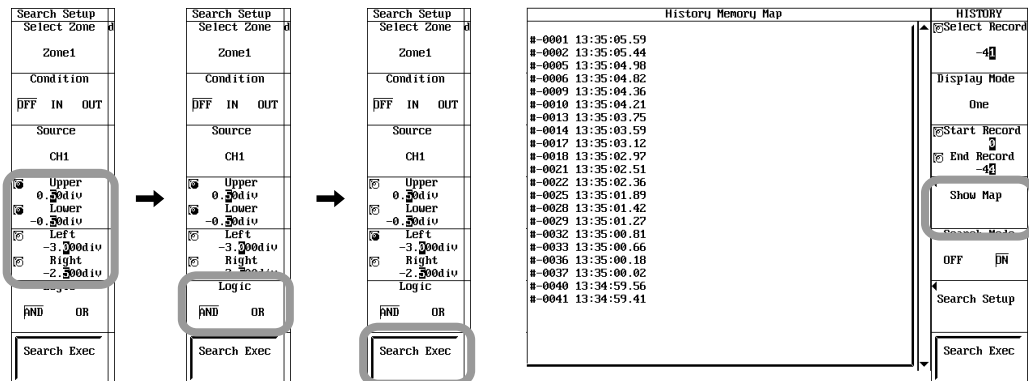

The diagram illustrates the sequence of screen displays for setting search parameters and viewing results:

- Search Setup 1:** Select Zone: Zone1, Condition: PFF IN OUT, Source: CH1, Upper: 0.500div, Lower: -0.500div, Left: -3.000div, Right: -2.500div, Logic: AND OR, Search Exec.
- Search Setup 2:** Select Zone: Zone1, Condition: PFF IN OUT, Source: CH1, Upper: 0.500div, Lower: -0.500div, Left: -3.000div, Right: -2.500div, Logic: AND OR, Search Exec.
- Search Setup 3:** Select Zone: Zone1, Condition: PFF IN OUT, Source: CH1, Upper: 0.500div, Lower: -0.500div, Left: -3.000div, Right: -2.500div, Logic: AND OR, Search Exec.
- History Memory Map:** A list of acquired data numbers and the time at acquisition end are displayed, such as #0001 13:35:05.59, #0002 13:35:05.44, #0005 13:35:04.98, #0006 13:35:04.82, #0009 13:35:04.36, #0010 13:35:04.21, #0013 13:35:03.75, #0014 13:35:03.59, #0017 13:35:03.12, #0018 13:35:02.97, #0021 13:35:02.51, #0022 13:35:02.36, #0025 13:35:01.89, #0028 13:35:01.42, #0029 13:35:01.27, #0032 13:35:00.81, #0033 13:35:00.66, #0036 13:35:00.18, #0037 13:35:00.02, #0040 13:34:59.56, #0041 13:34:59.41.
- HISTORY:** Select Record: -40, Display Mode: One, Start Record: 0, End Record: -40, Show Map, Search Setup, Search Exec.

## 11.3 Searching History Memory Data Using Parameters (History Search Function)

---

### **Explanation**

You can search for a waveform that matches the specified conditions from the past waveforms in the acquisition memory and display it.

#### **Select Param**

Four types of search condition can be registered in Parameter1 to Parameter4. You can set the channel that is to be searched, the search condition, and the search range for each search condition.

#### **Condition**

IN: Searches for waveforms entering the specified range of the specified parameter.

OUT: Searches for waveforms extending the specified range of the specified parameter.

OFF: Does not search for waveforms.

#### **Item Setup**

Assign search parameters to each trace channel. Choose one of the automated waveform measurement parameter.

The channels that can be specified are CH1 to CH16 and DSP1 to DSP6 (optional).

Waveforms of other channels are also displayed.

#### **Condition Range: Upper/Lower**

Set the range that defines the specified parameter's condition.

#### **Logic**

AND: Searches for waveforms that meet all search conditions from Param1 to Param4.

OR: Searches for waveforms that meet any one of the search conditions from Param1 to Param4.

#### **Parameter Measuring Range: Time Range1/Time Range2**

Set the measuring range of the specified parameter.

#### **Search Range of History Memory Data**

The search range is between the Start Rec and the End Rec.

#### **Search Order**

The search is carried out from the newest waveform to the oldest waveform.

#### **Show Map (A List of Time Stamps)**

Only the waveforms that are found are listed in Show Map. If the Search Mode is turned OFF, all waveforms are displayed.

# 11.4 Search Data Using Search and Zoom Function

<For a description of this function, refer to page 2-54.>

## Procedure

### Edge Search

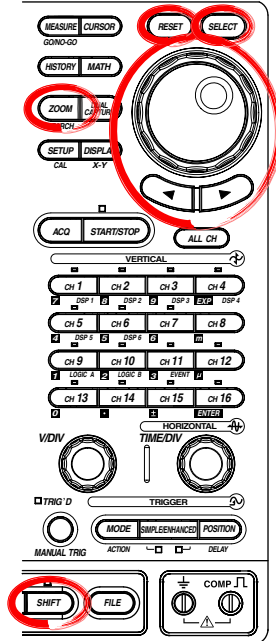

1. Press **SHIFT+ZOOM**.

#### Selecting the Search Type

- Press the **Type** soft key. The search type selection menu appears.
- Press the **Edge** soft key.

#### Setting the Search Condition

4. Press the **Setup** soft key. The search condition setup dialog box appears. Turn the **jog shuttle** to set the parameter.

#### Setting the Search Source Channel

5. Use the **jog shuttle** and **SELECT** to select Source.

#### Setting the Level

6. Use the **jog shuttle** and **SELECT** to set Level. Pressing **RESET** resets the level to 0 V.

#### Setting the Edge Polarity

7. Use the **jog shuttle** and **SELECT** to set Polarity to  $\uparrow$  or  $\downarrow$ .

#### Setting the Hysteresis

8. Use the **jog shuttle** and **SELECT** to set Hysteresis to  $\nearrow$ ,  $\nwarrow$ , or  $\nabla$ .

#### Setting the Search Count

9. Use the **jog shuttle** and **SELECT** to set Count. Pressing **RESET** resets the value to 1.

#### Setting the Search Start Point

10. Use the **jog shuttle** and **SELECT** to set Start Point. Pressing **RESET** resets the value to -5 divisions.

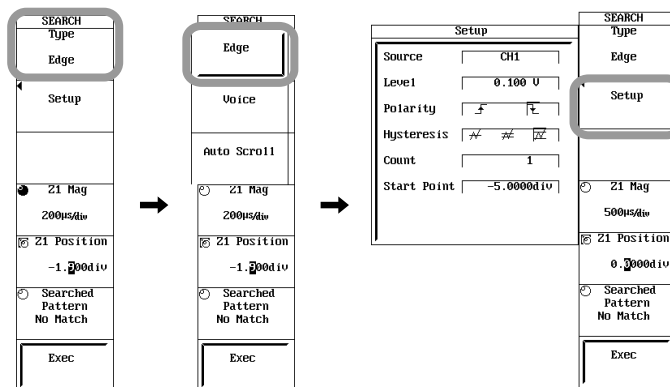

**Changing the Magnification and Display Position**

11. As with the zoomed waveform, you can change the zoom rate of Z1 and Z2 by pressing the **Z1 Mag/Z2 Mag** soft key and turning the **jog shuttle**.
12. As with the zoomed waveform, you can move the section that is being zoomed on Z1 or Z2 window by pressing the **Z1 Position/Z2 Position** soft key and turning the **jog shuttle**.

**Setting the Display Position of the Search Results**

(When Mode in the ZOOM Menu Is Set to Z1&Z2 or Main&Z1&Z2)

13. Press the **Result Window** soft key to select Z1 or Z2.

**Executing the Search**

14. Pressing the **Exec** soft key to execute the search. The Exec soft key changes to Abort. To abort the search, press the **Abort** soft key. The search results are displayed in the zoomed waveform display position selected in step 11. You can search 1000 times using the same conditions. While search is in execution,  is displayed at the upper left corner of the screen.

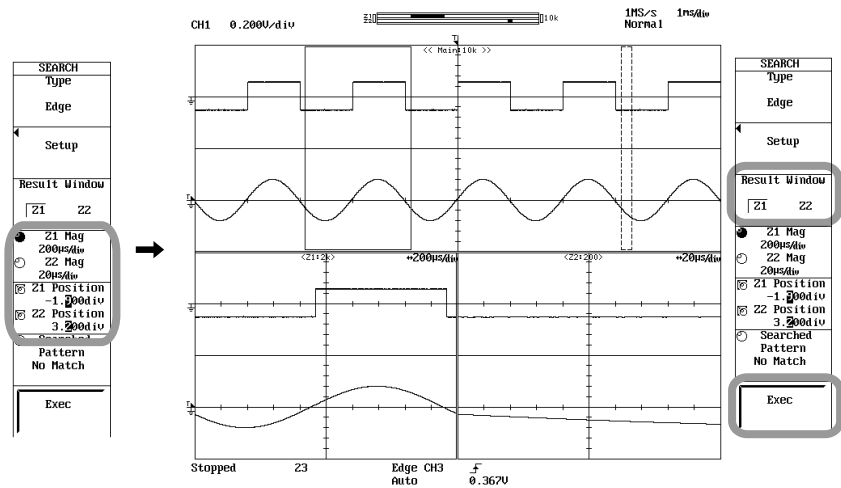

**Displaying the Previous Search Results**

15. Press the **Searched Pattern** soft key.
16. Turn the **jog shuttle** to specify the number of the search result you wish to display. Newer search results are displayed with higher numbers (result 2 is newer than result 1).

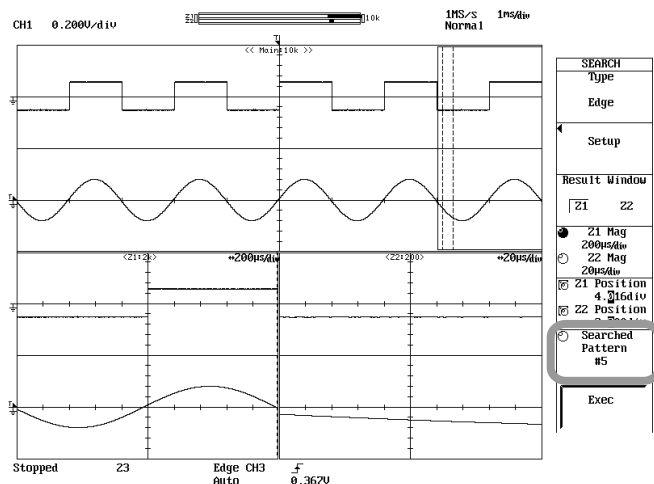

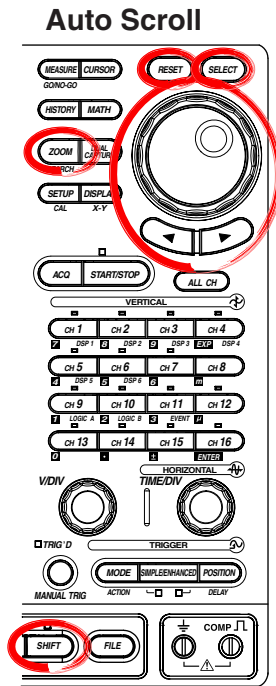

1. Press **SHIFT+ZOOM**.

### Selecting the Search Type

2. Press the **Type** soft key. The search type selection menu appears.
3. Press the **Auto Scroll** soft key.

### Selecting the Scroll Direction

4. Press the **Direction** soft key to set the scroll direction.

### Setting the Display Position of the Search Results

(When Mode in the ZOOM Menu Is Set to Z1&Z2 or Main&Z1&Z2)

5. Press the **Result Window** soft key to select Z1 or Z2.

### Changing the Magnification and Display Position

6. As with the zoomed waveform, you can change the zoom rate of Z1 and Z2 by pressing the **Z1 Mag/Z2 Mag** soft key and turning the **jog shuttle**.
7. As with the zoomed waveform, you can move the section that is being zoomed on Z1 or Z2 window by pressing the **Z1 Position/Z2 Position** soft key and turning the **jog shuttle**.

### Setting the Scroll Speed

8. Press the **Speed** soft key and turn the **jog shuttle** to set the scroll speed in the range from 1 to 10.

### Executing the Scroll

9. Press the **Exec** soft key. The zoom window automatically moves and the zoom position changes. When the scroll operation is in progress, the **Exec** soft key changes to the **Abort** soft key. Press the **Abort** soft key to abort the scroll operation.

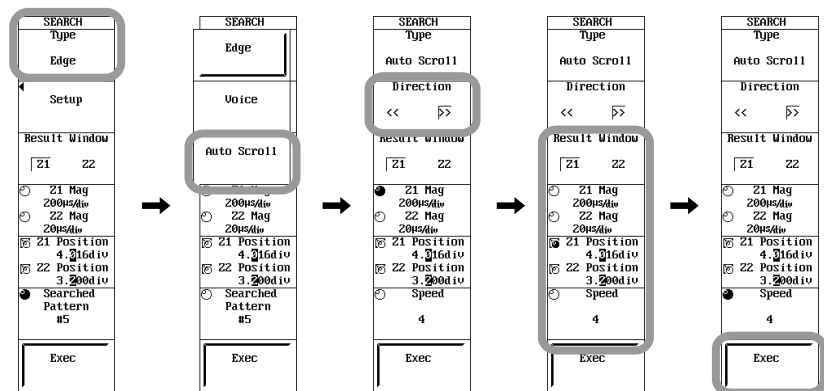



**Voice Search**

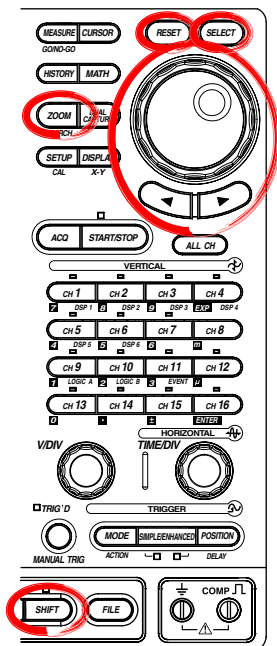

1. Press **SHIFT+ZOOM**.

**Selecting the Search Type**

2. Press the **Type** soft key. The search type selection menu appears.
3. Press the **Voice** soft key.

**Changing the Zoom Rate and Zoom Position**

4. Press the **Z1 Mag/Z2 Mag** soft key to change the zoom rate of Z1 or Z2 using the jog shuttle.
5. Press the **Z1 Position/Z2 Position** soft key to change the zoom position of Z1 or Z2 using the jog shuttle.

**Setting the Display Position of the Search Result Window**

(When Mode in the ZOOM menu is set to Z1&Z2 or Main&Z1&Z2)

6. Press the **Result Window** soft key to select Z1 or Z2.

**Executing the Search**

7. Press the **Exec** soft key. The search is executed. The Exec soft key changes to Abort. To abort the search, press the **Abort** soft key. The search results are displayed in the zoomed waveform display position selected in step 4.

**Playing the Voice Memo That Is Found**

8. Press the **Play Start** soft key. The voice memo that was found in step 7 is played. While the voice memo is being played, the Play Start soft key changes to Play Stop. To stop the voice memo while it is playing, press the **Play Stop** soft key.

**Displaying the Previous Search Results**

9. Press the **Searched Pattern** soft key.
10. Turn the **jog shuttle** to specify the number of the search result you wish to display. Newer search results are displayed with higher numbers (result 2 is newer than result 1).

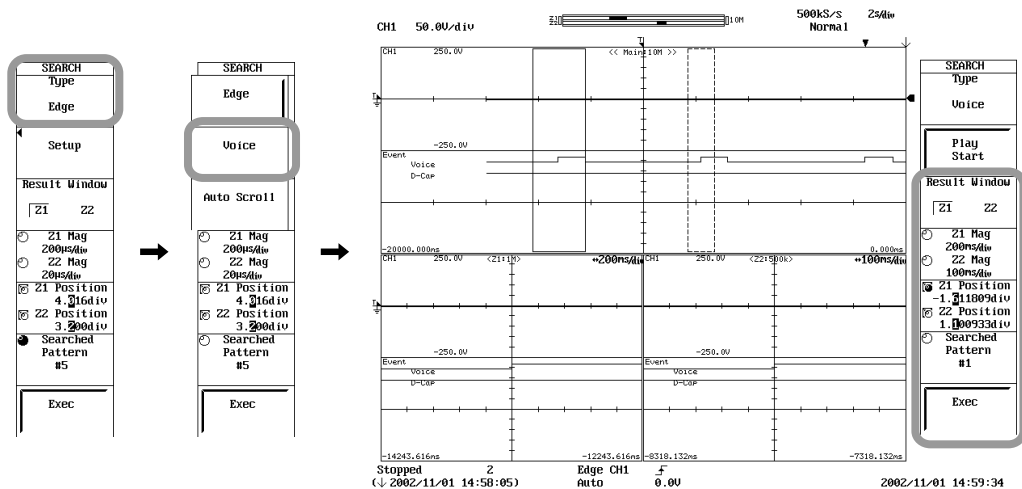

**Explanation**

When the data acquisition is stopped, a section of the waveform can be searched and displayed expanded.

**Search Type**

The following two search types are available.

- **Edge**  
Searches by counting the number of times waveform goes above (rising) or below (falling) a specified level from the starting point.
- **Auto Scroll**  
The zoom position automatically moves (auto scroll) in the specified direction. You can scroll through the zoomed waveform and stop the scrolling at the desired position.
- **Voice Search**  
Searches the start point (rising edge of the Voice bit of the event waveform) of the voice memo that has been recorded using the voice memo function (see section 7.9). Playing the voice memo that has been found is also possible.

**Search Condition for Edge Search: Setup**

- Source: Select the channel to be searched.
- Level: Set the level used to determine the rising or falling edge. The range is 10 divisions within the screen. The resolution varies depending on the module. For details, see section 6.5.
- Polarity: Select the polarity from the following:
- ↕: Search by the number of times the waveform passes from below the specified level to above the specified level.
  - ↘: Search by the number of times the waveform passes from above the specified level to below the specified level.
- Hysteresis: Set the hysteresis.
- Count: Set the number of times ↕ or ↘ is to be met. The selectable range is 1 to 1000000.
- Start Point: Set the start position of the search. The selectable range is from -5 to 5 divisions.

**Display Position of the Searched Waveform: Result Window**

When the zoom mode is set to Z1 & Z2 or Main & Z1 & Z2, you can select whether to display the searched waveform in the Z1 or Z2 window.

**Search Count: Searched Pattern**

- **For Edge Search**  
The search can be carried out up to 1000 times. The rising or falling edge is counted from the previous search position. In addition, the past search results can also be displayed.
- **For Voice Search**  
Search can be performed on waveforms that have voice memo recorded. The start point of the voice memo is counted from the previous search position. In addition, the past search results can also be displayed.

**Changing the Zoom Rate and Zoom Position**

The search results are displayed in the zoomed waveform display area. As with the zoomed waveform (see section 8.5), the zoom rate and position can be changed.

**Notes When Searching**

- Searching is not possible while the data acquisition is in progress.
- The search result is void if the following operations are carried out:
  - When data acquisition is started.
  - When Search Setup is changed.
- Patterns of waveforms that are not displayed are not searched.
- If the waveform is inverted or the offset voltage is changed, the search is performed on the waveform after the change.

**Determination When Using the Edge for the Search**

When the peak immediately after the rising edge of the waveform is less than or equal to the upper limit of the hysteresis or when the peak immediately after the falling edge is greater than or equal to the lower limit of the hysteresis, it is determined as false (not counted as a specified edge).

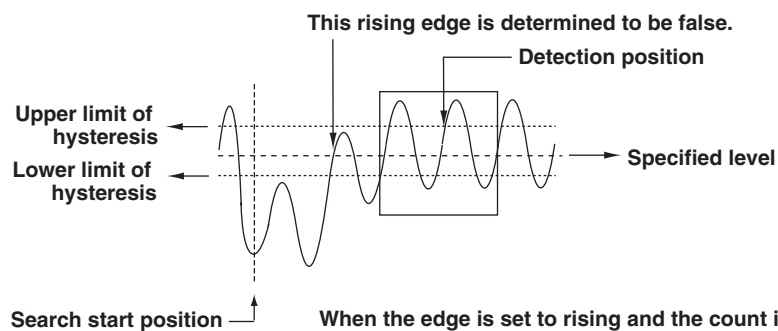

In addition, in the determination of logic waveforms, the determination is performed two points after the detected position.

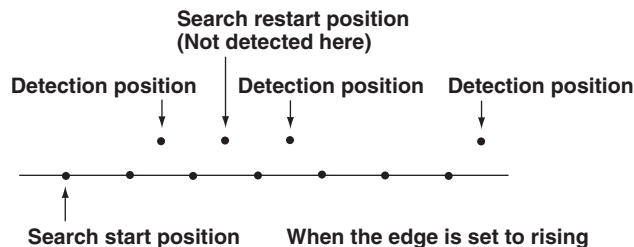

**Auto Scroll**

Set the scroll speed using 10 levels from 1 to 10. The speed increases as the number gets larger. You can only change the Direction and Speed while auto scroll is in progress.

**Playing of the Voice Memo (Voice Search)**

When using the voice search function, the voice memo that has been found can be played by pressing the Play Start soft key. The voice memo can be played only when the searched item is the newest waveform that has been acquired to the acquisition memory. While the voice memo is being played, Play Start indication changes to Play Stop. To stop the voice memo while it is playing, press the Play Stop soft key. When the voice memo is finished playing Play Stop automatically changes to Play Start even if the Play Stop soft key is not pressed.

**Note**

Waveform acquisition cannot be started when the SEARCH menu is displayed.

# 11.5 Measuring Waveforms Using Cursors

<For a description of this function, refer to page 2-55.>

## Procedure

### For H (Horizontal) Cursors (When Not Displaying the X-Y Waveform)

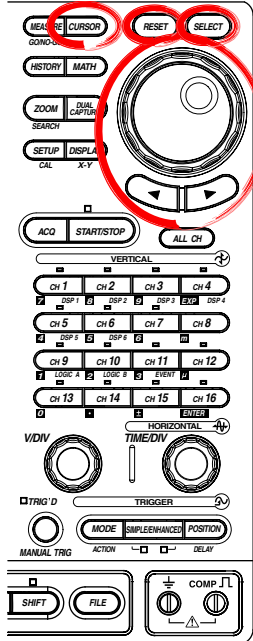

1. Press **CURSOR**.

#### Selecting the Cursor Type

2. Press the **Type** soft key. The cursor type selection menu appears.
3. Press the **Horizontal** soft key.

#### Selecting the Waveform to Be Measured

4. Press the **Trace** soft key. The trace selection menu appears.
5. Press the soft key corresponding to the desired waveform to select the waveform to be measured.

#### Moving the Cursor

6. Press the **Cursor1/Cursor2** soft key to set the jog shuttle control to Cursor1.
7. Turn the **jog shuttle** to move Cursor1.
8. Likewise, move Cursor2. If the jog shuttle control is set to both Cursor1 and Cursor2, both cursors are moved.

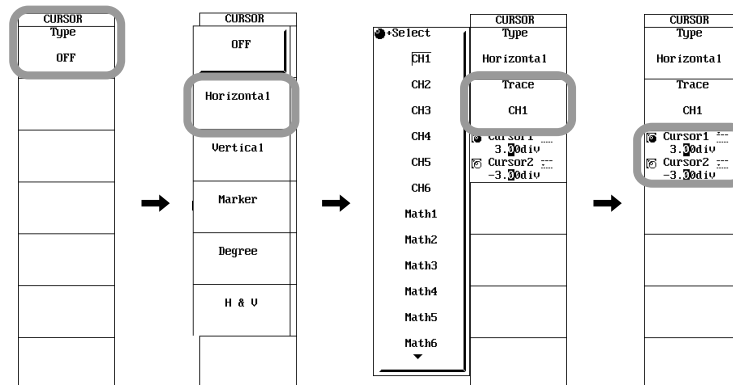

DSP1 to DSP6 are optional.

**For V (Vertical) Cursors (When Not Displaying the X-Y Waveform)**

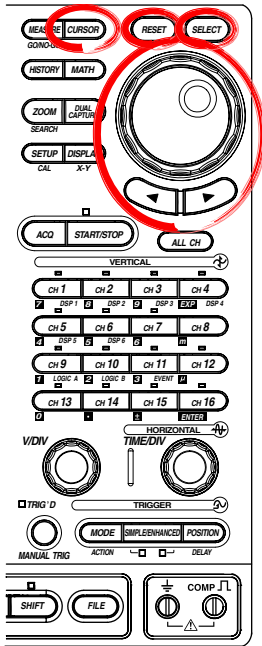

1. Press **CURSOR**.

**Selecting the Cursor Type**

2. Press the **Type** soft key. The cursor type selection menu appears.
3. Press the **Vertical** soft key.

**Selecting the Waveform to Be Measured**

4. Press the **Trace** soft key. The trace selection menu appears.
5. Press the soft key corresponding to the desired waveform to select the waveform to be measured.

If you set the waveform to be measured to All, LogicA, LogicB, or LogicA & LogicB, proceed to step 6. If not, proceed to step 9.

**Setting the Logic (When Trace Is Set to All, LogicA, LogicB, or LogicA & LogicB)**

6. Press the **Logic Setup** soft key. The logic setup menu appears.

**Selecting the Notation of Cursor Measurement Values**

7. Use the **jog shuttle** and **SELECT** to set Format to Binary or Hexa.

**Note**

The notation selected in step 7 applies to the notation of the numeric monitor display that is shown on the right side of the screen. For the procedure of displaying the numeric monitor, see section 8.13.

**Selecting the Read Direction of Bit Data**

8. Use the **jog shuttle** and **SELECT** to set Order to A1->A8 or B1->B8.

**Moving the Cursor**

6. Press the **Cursor1/Cursor2** soft key to set the jog shuttle control to Cursor1.
7. Turn the **jog shuttle** to move Cursor1.
8. Likewise, move Cursor2. If the jog shuttle control is set to both Cursor1 and Cursor2, both cursors are moved.

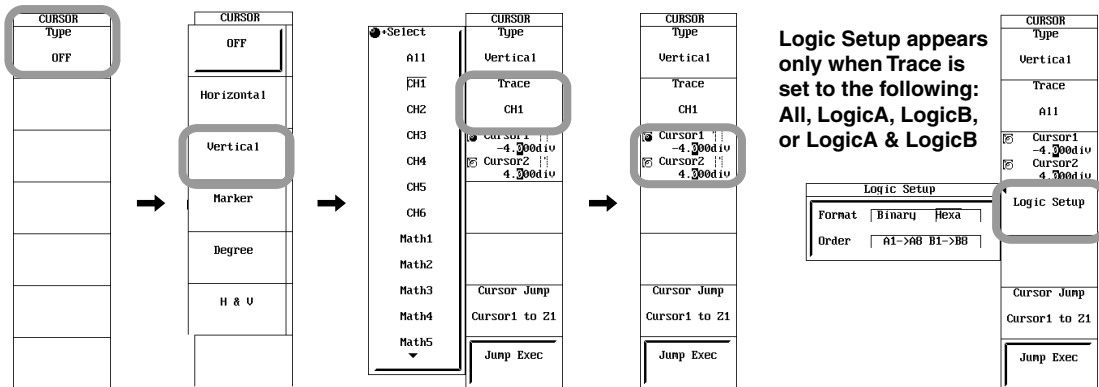

DSP1 to DSP6 are optional.

**For Marker Cursors (When Not Displaying the X-Y Waveform)**

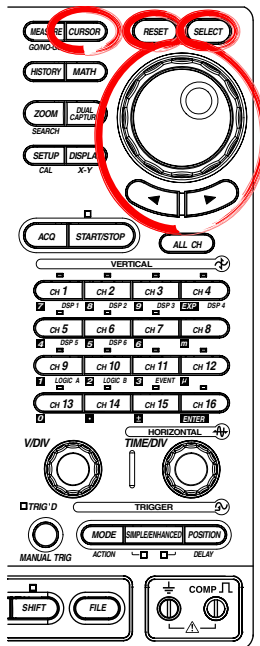

1. Press **CURSOR**.

**Selecting the Cursor Type**

2. Press the **Type** soft key. The cursor type selection menu appears.
3. Press the **Marker** soft key.

**Selecting the Marker**

4. Press the **Select** soft key to select the desired marker from M1 to M4.

**Selecting the Waveform to Be Measured**

5. Press the **Trace** soft key. The trace selection menu appears.
6. Press the soft key corresponding to the desired waveform to select the waveform to be measured.

**Moving the Cursor**

7. Press the **Position** soft key and turn the **jog shuttle** to move the cursor. As the cursor is moved, the displayed value of Position changes.

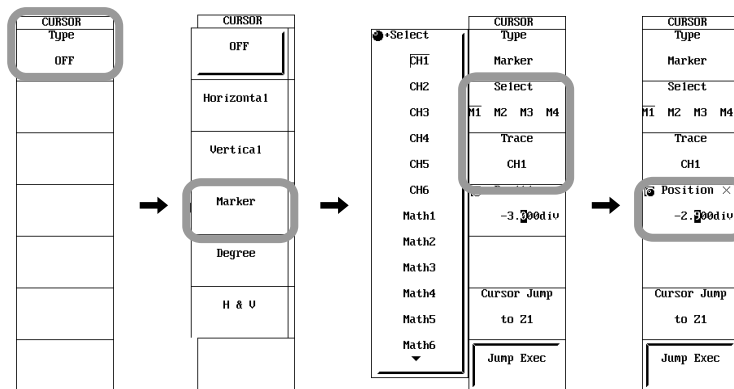

DSP1 to DSP6 are optional.

**For Angle (Degree) Cursors (When Not Displaying the X-Y Waveform)**

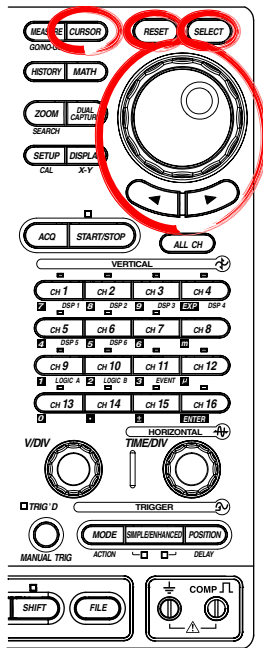

1. Press **CURSOR**.

**Selecting the Cursor Type**

2. Press the **Type** soft key. The cursor type selection menu appears.
3. Press the **Degree** soft key.

**Selecting the Waveform to Be Measured**

4. Press the **Trace** soft key. The trace selection menu appears.
5. Press the soft key corresponding to the desired waveform to select the waveform to be measured.

**Moving the Cursor**

6. Press the **Cursor1/Cursor2** soft key to set the jog shuttle control to Cursor1.
7. Turn the **jog shuttle** to move Cursor1.
8. Likewise, move Cursor2. If the jog shuttle control is set to both Cursor1 and Cursor2, both cursors are moved.

**Moving the Reference Cursor**

9. Press the **Ref1/Ref2** soft key to set the jog shuttle control to Ref1.
10. Turn the **jog shuttle** to move Ref1.
11. Likewise, move Ref2. If the jog shuttle control is set to both Ref1 and Ref2, both cursors are moved.

**Setting the Reference Angle**

12. Press the **Ref Value** soft key.
13. Turn the **jog shuttle** to set the reference angle in the range of 1 to 720.

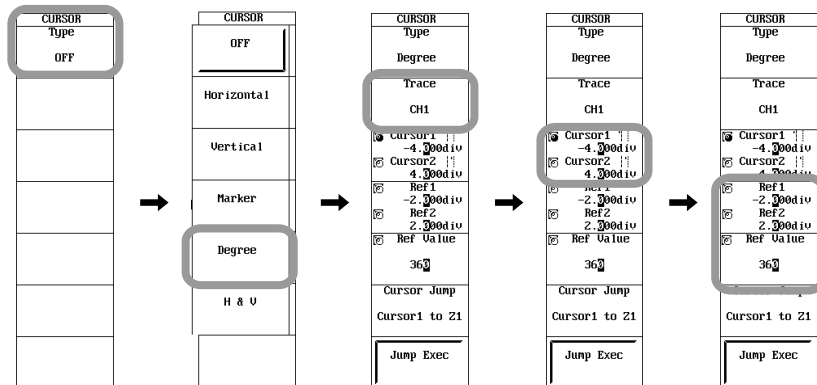

For H&V Cursors (When Not Displaying the X-Y Waveform)

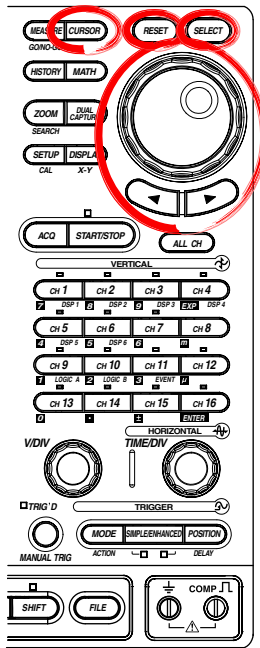

1. Press **CURSOR**.

**Selecting the Cursor Type**

2. Press the **Type** soft key. The cursor type selection menu appears.
3. Press the **H&V** soft key.

**Selecting the Waveform to Be Measured**

4. Press the **Trace** soft key.
5. Press the soft key corresponding to the desired waveform to select the waveform to be measured.

**Moving the Cursor**

6. Press the **Cursor1** / **Cursor2** soft key to set the jog shuttle control to Cursor1.
7. Turn the **jog shuttle** to move Cursor1.
8. Likewise, move Cursor2. If the jog shuttle control is set to both Cursor1 and Cursor2, both cursors are moved.
9. Move Cursor1 and Cursor2 by carrying out steps similar to steps 6 to 8.

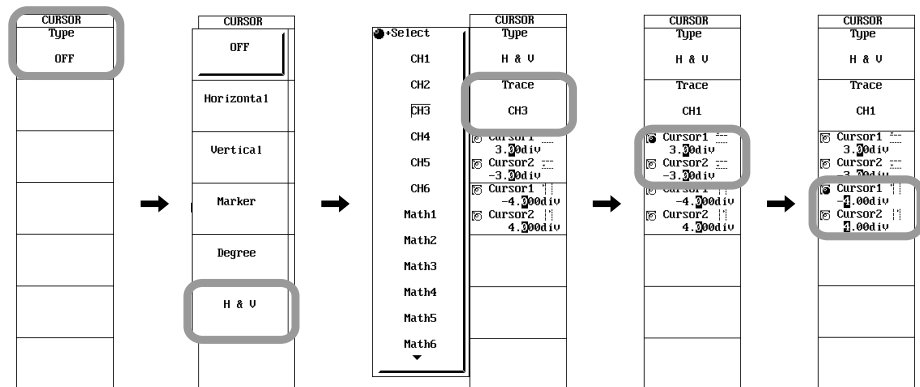

DSP1 to DSP6 are optional



### Cursor Jump (for V Cursor, Marker Cursor, and Angle Cursor: Only When Not Displaying the X-Y Waveform)

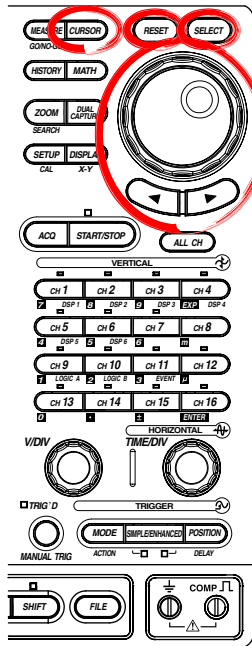

1. Follow steps 1-3 on the previous pages to set the Type to Vertical, Marker, or Degree.

#### Setting Jumps

2. Press the **Cursor Jump** soft key. A menu for selecting the cursor to be jumped and the jump destination appears.
3. Press the soft key corresponding to the type of jump to select the desired cursor and the destination.

#### Executing the Jump

4. Press the **Jump Exec** soft key. The cursor moves to the jump destination screen.

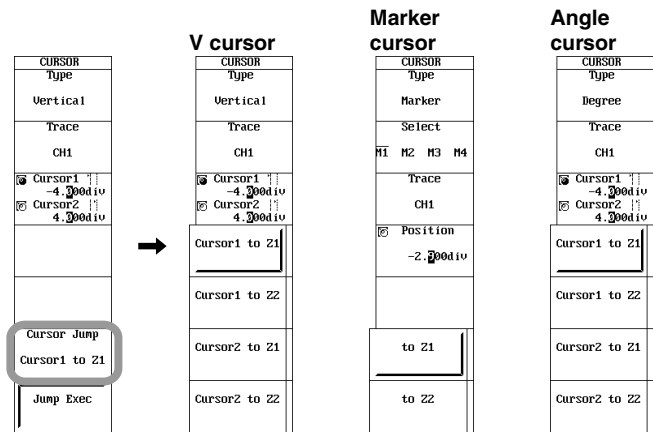

**For H (Horizontal) Cursors (When Displaying the X-Y Waveform)**

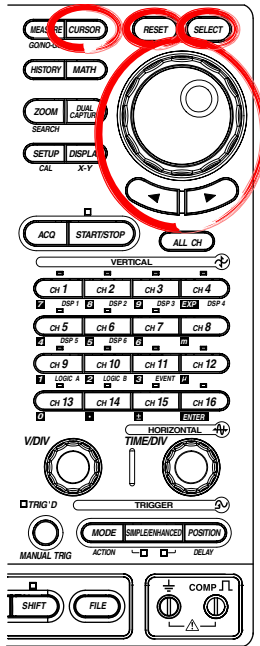

1. Press **CURSOR**.

**Selecting the Cursor Type**

2. Press the **Type** soft key. The cursor type selection menu appears.
3. Press the **Horizontal** soft key.

**Selecting the Waveform to Be Measured**

4. Press the **Trace** soft key.
5. If X Axis of the X-Y menu is set to Single, use the **jog shuttle** and **SELECT** to select the trace. If X Axis is set to Quad, press the soft key corresponding to the X-Y waveform (XY1 to XY4) to select the waveform to be measured.

**Moving the Cursor**

6. Press the **H Cursor1/H Cursor2** soft key to set the jog shuttle control to Cursor1.
7. Turn the **jog shuttle** to move Cursor1.
8. Likewise, move Cursor2. If the jog shuttle control is set to both H Cursor1 and H Cursor2, both cursors are moved.

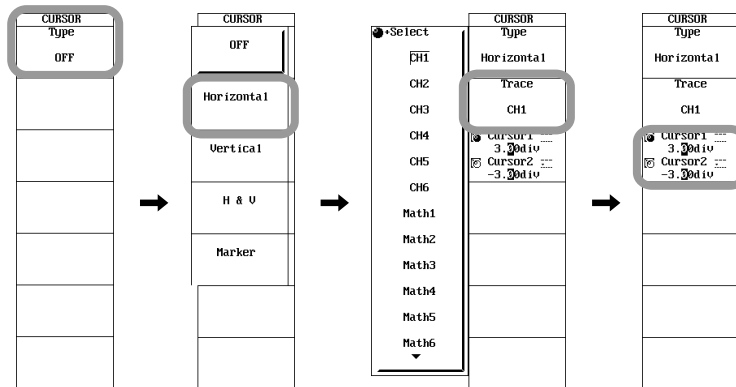

DSP1 to DSP6 are optional.

**For V (Vertical) Cursors (When Displaying the X-Y Waveform)**

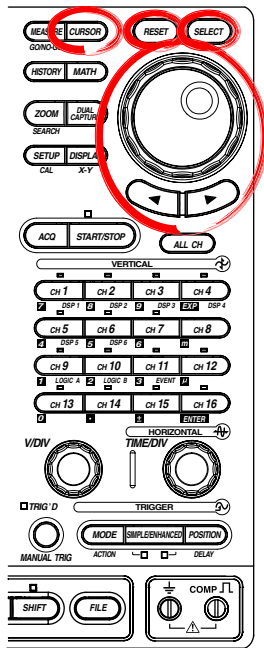

1. Press **CURSOR**.

**Selecting the Cursor Type**

2. Press the **Type** soft key. The cursor type selection menu appears.
3. Press the **Vertical** soft key.

**Selecting the Waveform to Be Measured**

4. Press the **Trace** soft key.
5. If X Axis of the X-Y menu is set to Single, the channel specified by X trace of the X-Y menu is displayed. Since this setting is for viewing purpose only, you cannot change it.

If X Axis is set to Quad, press the soft key corresponding to the X-Y waveform (XY1 to XY4) to select the waveform to be measured.

**Moving the Cursor**

6. Press the **V Cursor1/V Cursor2** soft key to set the jog shuttle control to V Cursor1.
7. Turn the **jog shuttle** to move V Cursor1.
8. Likewise, move V Cursor2. If the jog shuttle control is set to both V Cursor1 and V Cursor2, both cursors are moved.

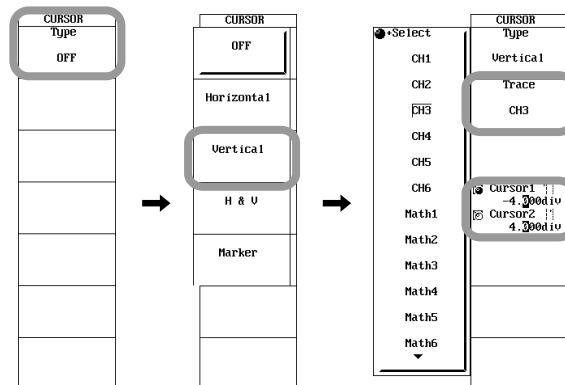

DSP1 to DSP6 are optional.

For H&V Cursors (When Displaying the X-Y Waveform)

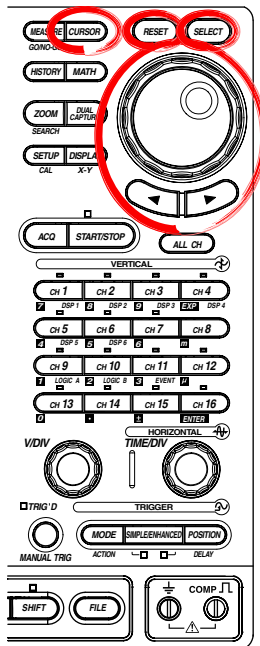

1. Press **CURSOR**.

**Selecting the Cursor Type**

2. Press the **Type** soft key. The cursor type selection menu appears.
3. Press the **H&V** soft key.

**Selecting the Waveform to Be Measured**

4. Press the **Trace** soft key.
5. If X Axis of the X-Y menu is set to Single, use the **jog shuttle** and **SELECT** to select the trace. If X Axis is set to Quad, press the soft key corresponding to the X-Y waveform (XY1 to XY4) to select the waveform to be measured.

**Moving the Cursor**

6. Press the **Cursor1** / **Cursor2** soft key to set the jog shuttle control to Cursor1.
7. Turn the **jog shuttle** to move Cursor1.
8. Likewise, move Cursor2. If the jog shuttle control is set to both H Cursor1 and H Cursor2, both cursors are moved.
9. Move Cursor1 and Cursor2 by carrying out steps similar to steps 6 to 8.

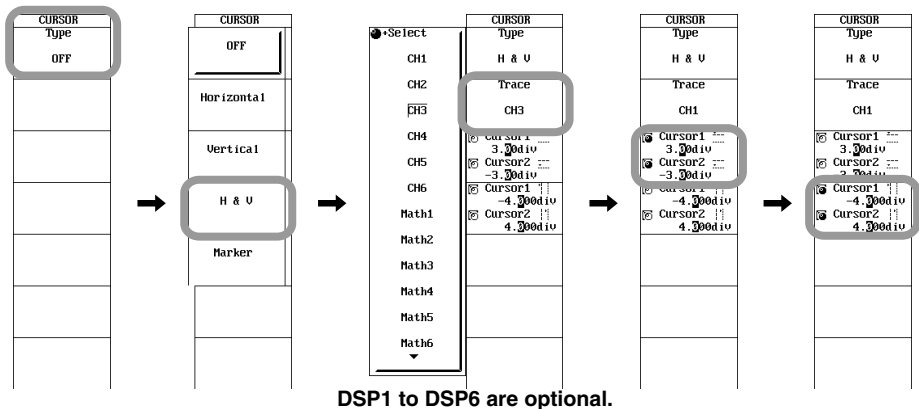

## 11.5 Measuring Waveforms Using Cursors

### For Marker Cursors (When Displaying the X-Y Waveform)

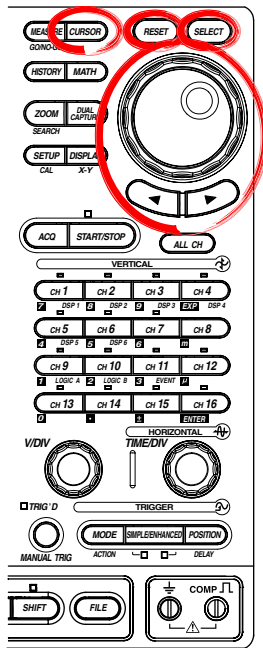

1. Press **CURSOR**.

#### Selecting the Cursor Type

2. Press the **Type** soft key. The cursor type selection menu appears.
3. Press the **Marker** soft key.

#### Selecting the Waveform to Be Measured

4. Press the **Trace** soft key.
5. If X Axis of the X-Y menu is set to Single, use the **jog shuttle** and **SELECT** to select the trace. If X Axis is set to Quad, press the soft key corresponding to the X-Y waveform (XY1 to XY4) to select the waveform to be measured.

#### Moving the Cursor

6. Press the **Position** soft key.
7. Turn the **jog shuttle** to move Position.

As the cursor is moved, the displayed value of Position changes.

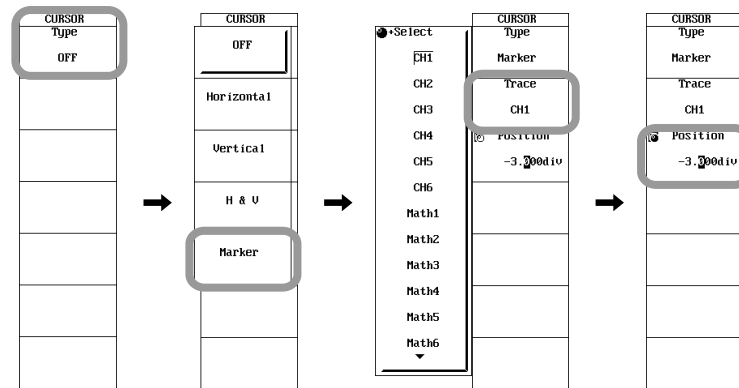

DSP1 to DSP6 are optional.

#### Note

The marker is displayed for the Y Trace (target Y-axis waveform) specified in the X-Y menu.

**Explanation****Limitations**

Cursor measurements cannot be made on the following waveforms.

- Snapshot waveforms
- Accumulated waveforms other than the newest waveform.

**Cursor Types and Measurement Items: Type (When Not Displaying the X-Y Waveform)**

- **H (Horizontal) Cursor**

Measures the Y-axis value at the cursor.

Y1: The Y-axis value at Cursor1

Y2: The Y-axis value at Cursor2

$\Delta Y$ : The difference between the Y-axis values at Cursor1 and Cursor2

- **V (Vertical) Cursor**

Measures the X-axis value at the cursor. Also choose the order of the data.

X1: The X-axis value at Cursor1

X2: The X-axis value at Cursor2

$\Delta X$ : The difference between the X-axis values at Cursor1 and Cursor2

$1/\Delta X$ : The inverse or the difference between the X-axis values at Cursor1 and Cursor2

Y1: The Y-axis value at Cursor1

Y2: The Y-axis value at Cursor2

$\Delta Y$ : The difference between the Y-axis values at Cursor1 and Cursor2

- **Marker Cursors**

Move the cursor on the waveform data and measure the waveform data values. M1 (Marker 1) to M4 (Marker 4) can be set on different waveforms.

Y1 to Y4: The Y-axis values of M1 to M4

$\Delta Y2$ : The difference between the Y-axis values of M1 and M2

$\Delta Y3$ : The difference between the Y-axis values of M1 and M3

$\Delta Y4$ : The difference between the Y-axis values of M1 and M4

X1 to X4: The X-axis values of M1 to M4

$\Delta X2$ : The difference between the X-axis values of M1 and M2

$\Delta X3$ : The difference between the X-axis values of M1 and M3

$\Delta X4$ : The difference between the X-axis values of M1 and M4

- **Angle Cursor (Degree)**

Set the measurement zero point (position of reference cursor Ref1) and the end point (position of the reference cursor Ref2) on the X-axis within the screen and assign an angle corresponding to the width of Ref1 and Ref2. Using this angle as a reference, this function measures the angle of the two angle cursors (Cursor1 and Cursor2).

X1: The angle of Cursor1 from Ref1

X2: The angle of Cursor2 from Ref1

$\Delta X$ : The angle difference between Cursor1 and Cursor2

Y1: The Y-axis value at Cursor1

Y2: The Y-axis value at Cursor2

$\Delta Y$ : The difference between the Y-axis values at Cursor1 and Cursor2

Range of reference width: 1 to 720°

- **H&V Cursor**

Measures the Y-axis and X-axis value at the cursor.

Y1: The Y-axis value at horizontal Cursor1

Y2: The Y-axis value at horizontal Cursor2

$\Delta Y$ : The difference between the Y-axis values at horizontal Cursor1 and horizontal Cursor2

X1: The X-axis value at vertical Cursor1

X2: The X-axis value at vertical Cursor2

$\Delta X$ : The difference between the X-axis values at vertical Cursor1 and vertical Cursor2

### **Cursor Types and Measurement Items: Type** **(When Displaying the X-Y Waveform)**

- **H (Horizontal) Cursor**  
Measures the Y-axis value at the cursor.  
Y1: The Y-axis value at H Cursor1  
Y2: The Y-axis value at H Cursor2  
 $\Delta Y$ : The difference between the Y-axis values at H Cursor1 and H Cursor2
- **V (Vertical) Cursor**  
Measures the X-axis value at the cursor.  
X1: The X-axis value at V Cursor1  
X2: The X-axis value at V Cursor2  
 $\Delta X$ : The difference between the X-axis values at V Cursor1 and V Cursor2
- **H&V Cursor**  
Measures the Y-axis and X-axis value at the cursor.  
Y1: The Y-axis value at H Cursor1  
Y2: The Y-axis value at H Cursor2  
 $\Delta Y$ : The difference between the Y-axis values at H Cursor1 and H Cursor2  
X1: The X-axis value at V Cursor1  
X2: The X-axis value at V Cursor2  
 $\Delta X$ : The difference between the X-axis values at V Cursor1 and V Cursor2
- **Marker Cursors**  
Move the cursor on the waveform data and measure the waveform data values.  
T: Display the time difference from the trigger point at the cursor  
X: The X-axis value at Cursor  
Y: The Y-axis value at Cursor

### **Movement Range of the Cursors (When Not Displaying the X-Y Waveform)**

- **H Cursor**  
Can be set in the range from -5 to +5 divisions from the center of the screen. The resolution is 0.01 divisions.
- **V Cursor, Marker Cursor, and Angle Cursor**  
Can be set in the range from -5 to +5 divisions from the center of the screen. The resolution is  $T/\text{div} \times 10 \div \text{display record length}$

### **Movement Range of the Cursors (When Displaying the X-Y Waveform)**

- **H Cursor, V Cursor, and H&V Cursor**  
Can be set in the range from -5 to +5 divisions from the center of the screen. The resolution is 0.01 divisions.
- **Marker Cursors**  
Can be set in the range from -5 to +5 divisions from the center of the screen. The resolution is  $T/\text{div} \times 10 \div \text{display record length}$ .

### **Display Format of Logic Waveforms (When Not Displaying the X-Y Waveform)**

You can set the following items when measuring logic waveforms using V cursors.

- **Selecting the Notation of Cursor Measurement Values: Format**  
Select the notation system used to display cursor measurement values.  
Binary: Displays values in binary notation.  
Hexa: Displays values in hexadecimal notation.
- **Read Direction of Bit Data: Order**  
Select the direction of reading the bit data of the logic input.  
A1->A8 B1->B8: Bit 1 to bit 8 of LogicA, bit 1 to bit 8 of LogicB  
B8->B1 A8->A1: Bit 8 to bit 1 of LogicB, bit 8 to bit 1 of LogicA

• **Combining of the Bit Data**

The data of LogicA and LogicB can be combined and handled as 16-bit data.

• **Handling of the OFF Bit**

- In binary notation, a dash is displayed at the bit.
- In hexadecimal notation, value is displayed as though the bit does not exist.

**Measurement Example of Logic Waveforms**

The values of measurement parameters Y1 and Y2 when the logic waveform is measured using vertical cursors are as follows.

• **When LogicA or LogicB is measured by itself and OFF bits do not exist**

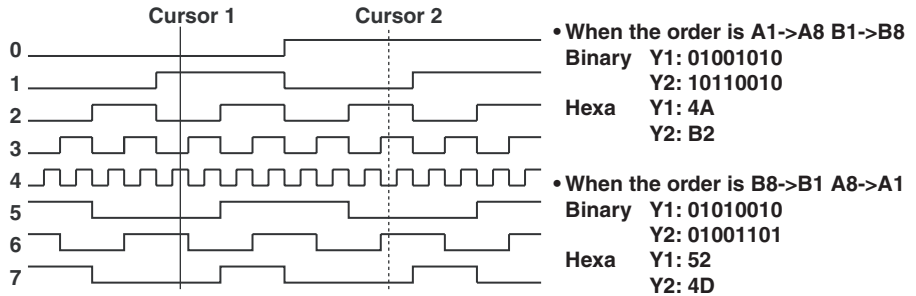

• **When LogicA or LogicB is measured by itself and OFF bits exist**

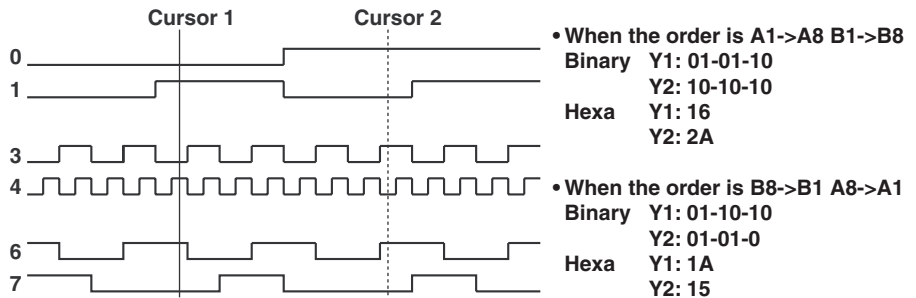

• **When LogicA & LogicB (combined data of LogicA and LogicB) is measured and OFF bits exist**

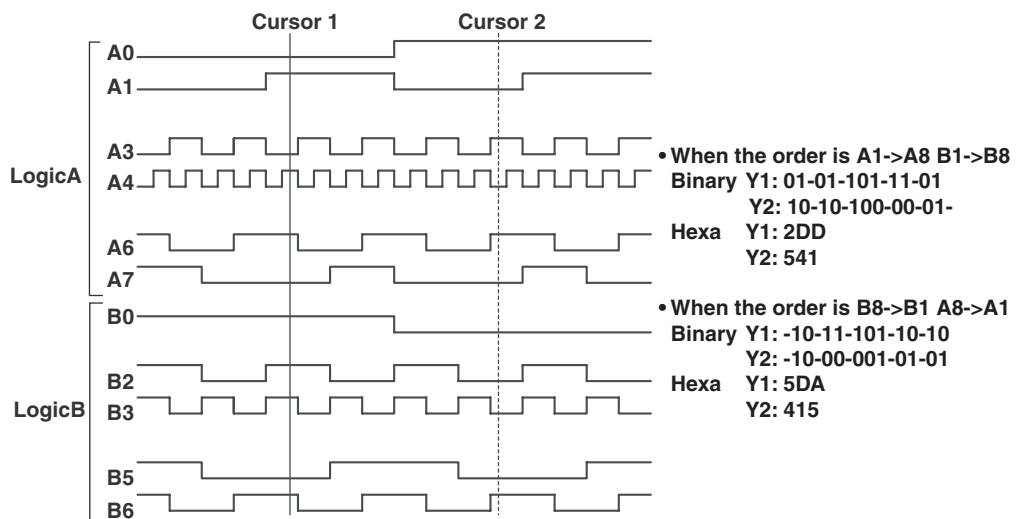



**Cursor Jump (When Not Displaying the X-Y Waveform)**

For V cursors, marker cursors, and angle cursors, you can move M1 to M4, Cursor1, and Cursor2 to the center of the zoom window. The cursors can be jumped in the following manner.

- **Marker Cursors**
  - to Z1: Make the selected marker jump to the Z1 window.
  - to Z2: Make the selected marker jump to the Z2 window.
- **V Cursor and Angle Cursor**
  - C1 to Z1: Make Cursor1 jump to the Z1 window
  - C1 to Z2: Make Cursor1 jump to the Z2 window
  - C2 to Z1: Make Cursor2 jump to the Z1 window
  - C2 to Z2: Make Cursor2 jump to the Z2 window

**Notes When Making Cursor Measurements**

- The time axis values are measured from the trigger position.
- The measured value will display “\*\*\*,” if the measurement is not possible.
- The pulse/rotate setting (see section 5.14) is applied to the X-axis (horizontal) measurement values in cursor measurements.
- If the sub waveform window is displayed when using the dual capture function, cursor measurements are made on the sub waveform. To make cursor measurements on the main waveform, turn OFF the sub waveform window in the DUAL CAPTURE menu.
- The results of cursor measurements on the sub waveforms of the dual capture function are displayed in italics.

**Selectable Range of Cursor Position**

In cursor measurements, measurement is performed on the data stored in the acquisition memory not on the displayed data. Since 1001 points along the time axis are used to displayed the waveform, the number of acquired data points is equal to “record length × 1.001.” If the record length is set to 10 kW, the number of acquired data points is 10010. Therefore, if the record length is set to 10 kW, 10 points of measured data will exist at the same position on the screen. The cursor display position is normally within ±5 divisions around the center position of the waveform display frame. In this case, if the cursor display position is set to +5 div, only 1 point out of 10 points can be measured even if there are 10 points of measured data at the same time axis position. In such case, the cursor position can be set in the range of –5 divisions to +5.009 divisions (if the record length is set to 10 kW). In other words, the data at the right end of the waveform display frame can be measured by setting the cursor position in the range of 5.000 to 5.009 divisions. Because the number of points at the same time axis position increases as the record length gets larger, the range varies depending on the record length (5.000 to 5.0099 divisions for 100 kW).

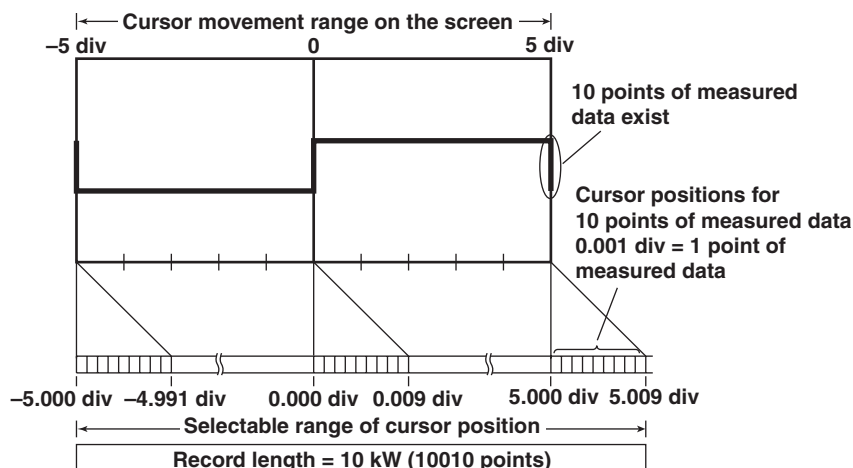

# 11.6 Automated Measurement of Waveform Parameters

<For a description of this function, refer to page 2-56.>

## Procedure

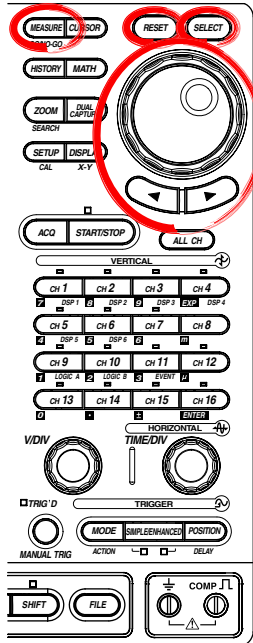

1. Press **MEASURE**.
2. Press the **Mode** soft key , and press the ON soft key.

### Selecting the Measurement Parameter

3. Press the **Item Setup** soft key. The measurement parameter setup dialog box appears.
- **Selecting the Waveform to Be Measured**
    4. Press the **Trace** soft key. The trace selection menu appears.
    5. Use the **jog shuttle** and **SELECT** to select waveform to be measured.
  - **Selecting the Measurement Parameter**
    6. Use the **jog shuttle** and **SELECT** to turn ON/OFF each item on the measurement parameter dialog box.  
You can turn OFF all parameters at once by pressing the **All Clear**.  
You can copy the current parameter settings to all traces by pressing the **Copy to All Trace** soft key.
    7. Repeat steps 4 to 6 as many times as necessary.

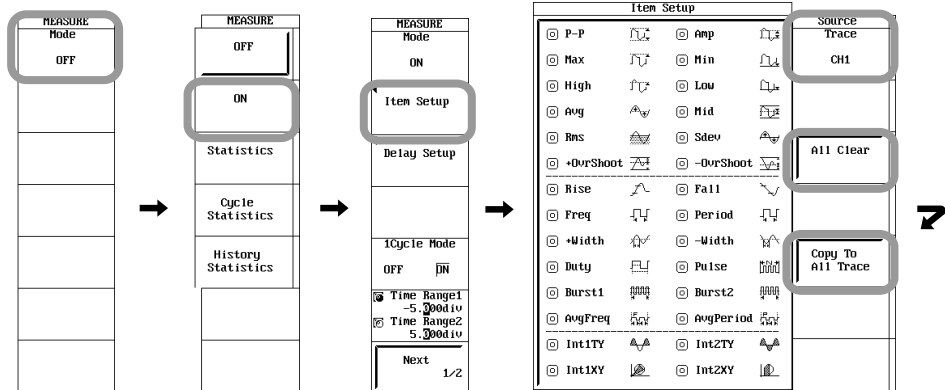

Item Setup				Source Trace
<input checked="" type="checkbox"/> P-P	<input checked="" type="checkbox"/> Amp	<input checked="" type="checkbox"/> Min	<input checked="" type="checkbox"/> CH1	CH1
<input checked="" type="checkbox"/> Max	<input checked="" type="checkbox"/> Low	<input checked="" type="checkbox"/> Mid	<input checked="" type="checkbox"/> CH2	CH2
<input checked="" type="checkbox"/> High	<input checked="" type="checkbox"/> Sdev	<input checked="" type="checkbox"/> -OvrShoot	<input checked="" type="checkbox"/> CH3	CH3
<input checked="" type="checkbox"/> Avg	<input checked="" type="checkbox"/> Rise	<input checked="" type="checkbox"/> -OvrShoot	<input checked="" type="checkbox"/> CH4	CH4
<input checked="" type="checkbox"/> Rms	<input checked="" type="checkbox"/> Freq	<input checked="" type="checkbox"/> Fall	<input checked="" type="checkbox"/> CH5	CH5
<input checked="" type="checkbox"/> +OvrShoot	<input checked="" type="checkbox"/> +Width	<input checked="" type="checkbox"/> Period	<input checked="" type="checkbox"/> CH6	CH6
<input checked="" type="checkbox"/> Rise	<input checked="" type="checkbox"/> Duty	<input checked="" type="checkbox"/> Pulse	<input checked="" type="checkbox"/> Math1	Math1
<input checked="" type="checkbox"/> Freq	<input checked="" type="checkbox"/> Burst1	<input checked="" type="checkbox"/> Burst2	<input checked="" type="checkbox"/> Math2	Math2
<input checked="" type="checkbox"/> +Width	<input checked="" type="checkbox"/> AvgFreq	<input checked="" type="checkbox"/> AvgPeriod	<input checked="" type="checkbox"/> Math3	Math3
<input checked="" type="checkbox"/> Duty	<input checked="" type="checkbox"/> Int1TY	<input checked="" type="checkbox"/> Int2TY	<input checked="" type="checkbox"/> Math4	Math4
<input checked="" type="checkbox"/> Burst1	<input checked="" type="checkbox"/> Int1XY	<input checked="" type="checkbox"/> Int2XY		
<input checked="" type="checkbox"/> AvgFreq				
<input checked="" type="checkbox"/> AvgPeriod				
<input checked="" type="checkbox"/> Int1TY				
<input checked="" type="checkbox"/> Int2TY				
<input checked="" type="checkbox"/> Int1XY				
<input checked="" type="checkbox"/> Int2XY				

DSP1 to DSP6 are optional.

**Setting the Delay**

8. Press the **Delay Setup** soft key. The Delay Setup dialog box appears.
- **Selecting the Waveform to Be Measured**
    9. Press the **Trace** soft key. The trace selection menu appears.
    10. Use the **jog shuttle** and **SELECT** to select waveform to be measured.
  - **Setting the Delay**
    11. Use the **jog shuttle** and **SELECT** to set Mode of the Delay Setup dialog box to Time, Degree, or OFF.
    12. Use the **jog shuttle** and **SELECT** to set Polarity under Measure to  $\uparrow$  (rising edge) or  $\downarrow$  (falling edge).
    13. Use the **jog shuttle** and **SELECT** to set Edge Count under Measure.
    14. Use the **jog shuttle** and **SELECT** to select whether the trace or the trigger is to be the reference. If you select Trace, proceed to step 15.
    15. Use the **jog shuttle** and **SELECT** to set Trace under Reference.
    16. Use the **jog shuttle** and **SELECT** to set Polarity under Reference to  $\uparrow$  (rising edge) or  $\downarrow$  (falling edge).
    17. Use the **jog shuttle** and **SELECT** to set Edge Count under Reference.

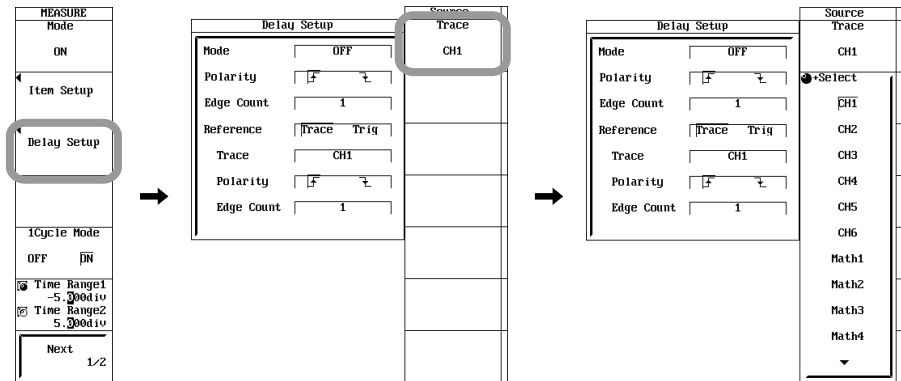

DSP1 to DSP6 are optional.

**Setting the 1 Cycle Mode**

- 18. Press the **1Cycle Mode** soft key to select ON or OFF.

**Setting the Measurement Range**

- 19. Press the **Time Range1/Time Range2** soft key to set the jog shuttle control to Time Range1.
- 20. Turn the **jog shuttle** to set the measurement start point.
- 21. Likewise, set Time Range2 (measurement end point).

**Note**

Up to 10 MW from the measurement start point (Time Range1) are measured.

**Selecting the Target Waveform for Distal, Mesial, and Proximal Points**

- 22. Press the **Next 1/2** soft key
- 23. Press the **Trace** soft key. The trace selection menu appears.
- 24. Press the soft key corresponding to the desired waveform to select the target waveform.

**Setting the Distal, Mesial, and Proximal Unit**

- 25. Press the **Dist/Prox Mode** soft key to set the unit for distal, mesial, and proximal points to % or Unit. If the target waveform was set to DSP1 to DSP6 (optional) in steps 23 and 24, only % is selectable.

**Setting Distal, Mesial, and Proximal**

- 26. Press the **Distal, Mesial, or Proximal** soft key.
- 27. Turn the **jog shuttle** to set the distal, mesial, or proximal point.

**Selecting the High and Low Setting**

- 28. Press the **High/Low Mode** soft key to select Auto or MAX-MIN.

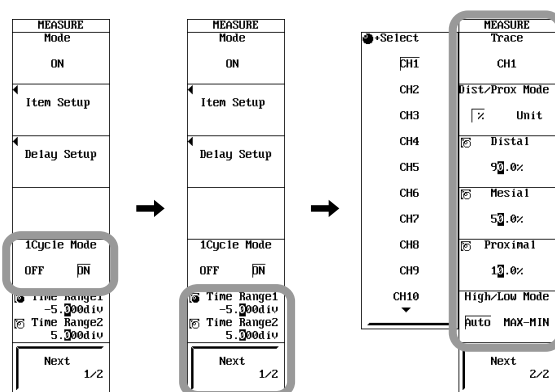

DSP1 to DSP6 are optional.

**Explanation**

**Limitations**

Automated measurement of waveform parameters cannot be performed on the following waveforms.

- Snapshot waveforms
- Accumulated waveforms other than the newest waveform.
- Sub waveforms measured using the dual capture function (version 3.10 or earlier. However, if you load the measured data of Version 3.10 or earlier into a DL750/DL750P of Version 4.01 or later, automated measurement of waveform parameters is possible.)

**Measurement Parameters: Item Setup**

You can select among the 28 types of measurement parameters shown below and delay between channels. Up to 48000 combinations of parameters of all traces (CH1 to CH16 and Math1 to Math8) can be saved.

• **Voltage-axis Parameters**

<b>P-P</b> : Peak to Peak Value (MAX - MIN) [V]	<b>-Ovr shoot</b> : Undershoot Value (-Ovr) <sup>1</sup> (LOW - MIN)/(HIGH - LOW) x 100 [%]
<b>Max</b> : Maximum Voltage [V]	<b>+Ovr shoot</b> : Overshoot Value (+Ovr) <sup>1</sup> (MAX - HIGH)/(HIGH - LOW) x 100[%]
<b>Min</b> : Minimum Voltage [V]	<b>High</b> : High Level Voltage [V]
<b>Rms</b> <sup>1</sup> : Root Mean Square Value (1/√n)(∑xi) <sup>2</sup> 1/2 [V]	<b>Low</b> : Low Level Voltage [V]
<b>Avg</b> : Average Voltage (1/n)∑xi [V]	<b>Amp</b> : Amplitude (High-Low) [V]
<b>Sdev</b> : Standard Deviation (SDv) <sup>2</sup> (1/n(∑xi <sup>2</sup> - (∑xi) <sup>2</sup> /n)) <sup>1/2</sup> [V]	<b>Mid</b> : (MAX+MIN)/2

1. If Rms is ON on the channels (Math1 to Math8) on which power spectrum computation (PS or PSD) is selected, the screen shows "Rms = overall value." For details on the power spectrum computation, see sections 10.3 and 10.5. For details on the overall value, see page App-19.
2. ( ) shows the corresponding name at the measurement item setting screen.

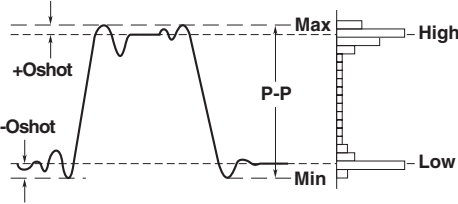

• **Time-axis Parameters**

<b>Rise</b> : Rise Time [s]	<b>+Width</b> : Width (s) Greater than the Mesial Value (+Wd) <sup>1</sup>
<b>Fall</b> : Fall Time [s]	<b>-Width</b> : Width (s) Smaller than the Mesial Value (-Wd) <sup>1</sup>
<b>Freq</b> : Frequency [Hz], 1/PERIOD	<b>Duty</b> : Duty Ratio + Width/Period x 100[%]
<b>Period</b> : Period [s]	
<b>Avg Freq</b> : Mean Frequency in (FR-A) <sup>1</sup> Measuring Range[Hz]	
<b>Avg Period</b> : Mean Period in (PR-A) <sup>1</sup> Measuring Range[s]	

1. ( ) shows the corresponding name at the measurement item setting screen.

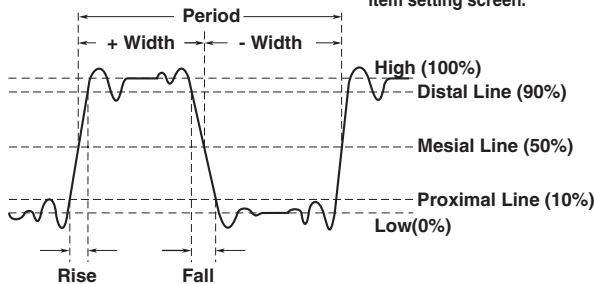

**Pulse** : Pulse Count (PlsN) Set the measurement range (T-Range) to match the pulse width of the signal being measured.

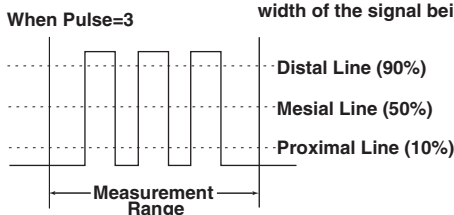

Automated measurement of various waveform parameters are performed on the data stored to the acquisition memory. Up to 48000 data points among the parameters that are automatically measured can also be saved to a file. (For details, see section 13.10.)

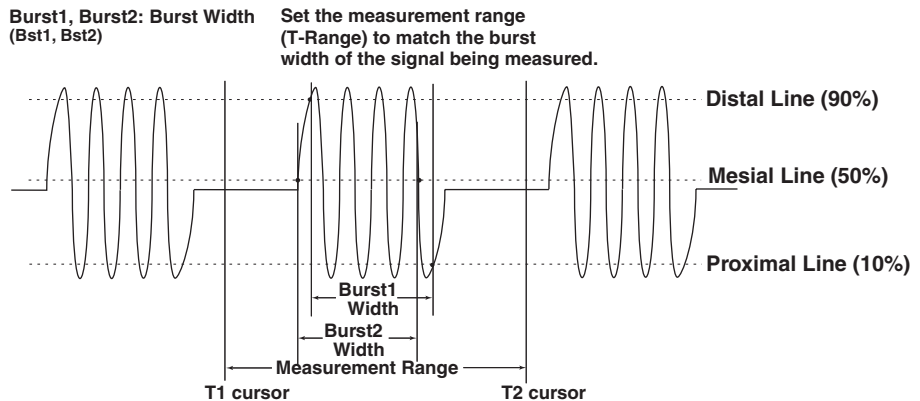

• **Other Measurement Parameters**

Int1TY: The area under the positive amplitude

Int2TY: The area under the positive amplitude – the area under the negative amplitude

Int1XY: The summation of the triangular area of the X-Y waveform

Int2XY: The summation of the trapezoidal area of the X-Y waveform

For details regarding the area calculations, see Appendix 3, “How to Calculate the Area of a Waveform.”

**Setting the Delay**

The time difference between the rising or falling edges of trace waveforms or trigger points is called the delay between channels.

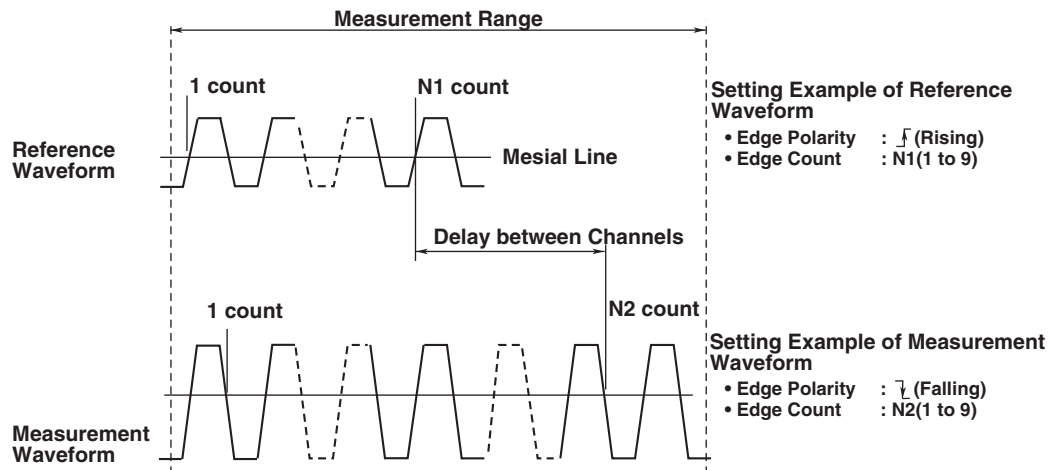

- If Mode is set to Time or Degree, measurements will be made. The default setting is OFF.  
 Time: Display the delay between channels as a time  
 Degree: Display the delay between channels as an angle  
 $\text{Degree} = \text{Delay (s)} / \text{Period (s)} \times 360 \text{ (deg)}$ . The period is that of a reference waveform.
- Select  $\uparrow$  (rising edge) or  $\downarrow$  (falling) for the slope of the edge to be detected using Edge Polarity. The default setting is rising.
- Set the number of edges to detect before actually considering it a detection point in Edge Count. The range is an integer from 1 to 9. The default value is 1.

## 11.6 Automated Measurement of Waveform Parameters

---

- The voltage level at the detection point is the mesial point.
- The parameter name when the measured value is displayed is (Dly).

### **Note**

If the Mode is set to Degree and the reference waveform is Trig, the measured value shows

“\*\*\*”

---

### **1 Cycle Mode**

This mode is used to compute items related to the voltage axis or the area over one cycle after determining the cycle. This mode is suited to items such as Rms and Avg that produce errors depending on the measurement range.

This mode does not affect the items related to the time axis or the area of the X-Y waveforms.

### **Setting the Measurement Range (Time Range1/Time Range2)**

By default, the  $\pm 5$  divisions of the time axis display frame is the measurement range. However, this range can be shortened. The measurement range is specified using two vertical cursors. The measurement start point is the position where the fine dotted line is located, and the measurement end point is the position where the coarse dotted line is located. Up to 10 MW from the measurement start point (Time Range1) are measured. The concept of the measurement range is analogous to the concept of the selectable range of cursor display position in cursor measurement.

For details, see section 11.5, “Selectable Range of Cursor Position.”

### **Setting the Distal, Mesial, and Proximal Unit: Dist/Prox Mode**

Select the method of assigning the three levels that are used as references in measurements such as the rise and fall times.

- **%**  
The distal, mesial, and proximal values are set in terms of percentages when High of any trace (CH1 to CH16, DSP1 to DSP6 (optional), Math1 to Math8) and Low are taken to be 100.0% and 0.0%, respectively.
- **Unit**  
Set the distal, mesial, and proximal values of any trace (CH1 to CH16, Math1 to Math8) to arbitrary voltage or temperature values.

### **Setting Distal, Mesial, and Proximal**

Unit:	Dist/Prox Mode
Proximal range:	0.0 to 100.0 (resolution: 0.1%) or voltage or temperature corresponding to $\pm 10$ divisions (resolution: varies depending on the module). For details, see section 5.3.)
Mesial range:	0.0 to 100.0 (resolution: 0.1%) or voltage or temperature corresponding to $\pm 10$ divisions (resolution: varies depending on the module). For details, see section 5.3.)
Distal range:	0.0 to 100.0 (resolution: 0.1%) or voltage or temperature corresponding to $\pm 10$ divisions (resolution: varies depending on the module). For details, see section 5.3.)

**Selecting the High and Low Setting: High/Low Mode**

High indicates the 100% level in measurements such as the rise or fall time. And, Low indicates the 0% level. Select the assignment method of High and Low from the following two methods.

- **Auto**  
Sets the higher amplitude level to High and lower level to Low within the measurement range based on the voltage level frequency of the waveform by taking the effects of ringing, spikes, etc. into consideration. This method is best-suited when measuring rectangular waveforms and pulse waveforms.
- **MAX-MIN**  
Sets the maximum value to High and lowest value to Low in the measurement range. This method is best-suited when measuring sine waveforms, ramp waveforms, etc. It is not suited for measurement of waveforms with ringing and spikes.

**Notes When Performing Automated Measurement of Waveform Parameters**

- The measurement value displays “\*\*\*\*” if the measurement is not possible (such as when the measurement range is greater than or equal to 10 MW).
- For waveforms of small amplitude, correct measurements may not be possible.
- If there are two or more cycles of a waveform in the measurement range, the measurement is made on the first waveform.
- Automated measurement is not possible on logic waveforms.
- If automated measurement is made on waveforms that are measured using the realtime recording function, the execution of the automated measurement takes a long period due to the hard disk access.
- Depending on the conditions such as the memory length, the number of measured items, and the input waveform, the execution of the automated measurement may take an extended period. While automated measurement is in progress,  is indicated at the upper left corner of the screen.
- To abort the automated measurement, set Mode to OFF. The process is aborted at that point.
- If X Axis is set to Quad in the X-Y menu, Int1XY and Int2XY cannot be measured.
- For FFT waveforms, only Max and Min can be measured.
- If the sub waveform window of the dual capture function is showing, automated measurement of waveform parameters is performed on the sub waveform. To perform automated measurement of waveform parameters on the main waveform, turn OFF the sub waveform window.
- The results of automated measurements on the sub waveforms of the dual capture function are displayed in italics.



# 11.7 Performing Statistical Processing

<For a description of this function, refer to page 2-57.>

## Procedure

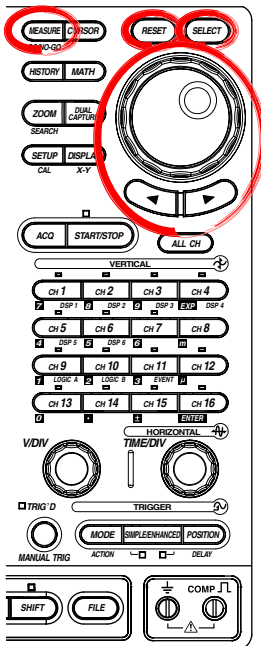

## Setting Normal Statistical Processing

1. Press **MEASURE**.
2. Press the **Mode** soft key to select **Statistics**.
3. Press the **Item Setup** soft key. The measurement parameter dialog box and the measurement channel menu appear.
4. Press the **Trace** soft key and use the **jog shuttle** and **SELECT** to select the measurement channel.
5. Turn the **jog shuttle** to move the cursor to the parameter you wish to turn ON.
6. Press **SELECT** to turn on the parameter selected in step 5.  
You can turn OFF all parameters at once by pressing the **All Clear**. You can copy the current parameter settings to all traces by selecting “**Copy to All Trace**.”
7. Repeat steps 4 to 6 as many times as necessary. Press **ESC**.

The setting of other parameters is the same as the automated measurement of waveform parameters (see step 8 and following steps in section 11.6).

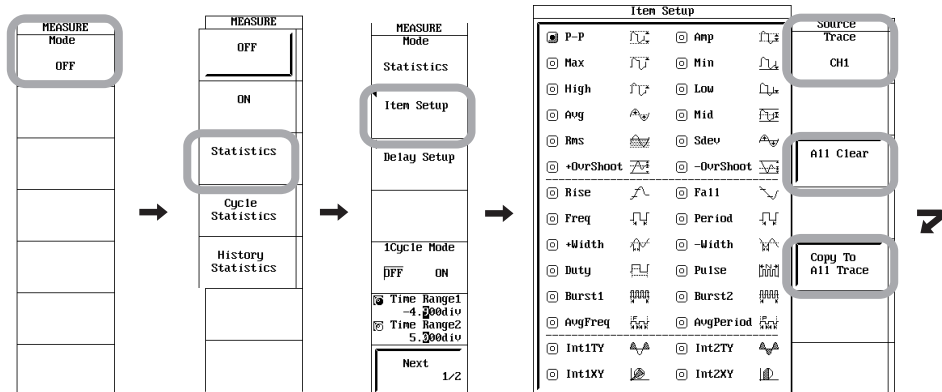

Item Setup			Source Trace
<input checked="" type="checkbox"/> P-P	<input type="checkbox"/> Amp	<input type="checkbox"/>	CH1
<input type="checkbox"/> Max	<input type="checkbox"/> Min	<input type="checkbox"/>	CH1
<input type="checkbox"/> High	<input type="checkbox"/> Low	<input type="checkbox"/>	CH1
<input type="checkbox"/> Avg	<input type="checkbox"/> Mid	<input type="checkbox"/>	CH2
<input type="checkbox"/> Rms	<input type="checkbox"/> Sdev	<input type="checkbox"/>	CH3
<input type="checkbox"/> +OverShoot	<input type="checkbox"/> -OverShoot	<input type="checkbox"/>	CH4
<input type="checkbox"/> Rise	<input type="checkbox"/> Fall	<input type="checkbox"/>	CH5
<input type="checkbox"/> Freq	<input type="checkbox"/> Period	<input type="checkbox"/>	CH6
<input type="checkbox"/> +Width	<input type="checkbox"/> -Width	<input type="checkbox"/>	CH13
<input type="checkbox"/> Duty	<input type="checkbox"/> Pulse	<input type="checkbox"/>	CH14
<input type="checkbox"/> Burst1	<input type="checkbox"/> Burst2	<input type="checkbox"/>	CH15
<input type="checkbox"/> AvgFreq	<input type="checkbox"/> AvgPeriod	<input type="checkbox"/>	CH16
<input type="checkbox"/> Int1TY	<input type="checkbox"/> Int2TY	<input type="checkbox"/>	
<input type="checkbox"/> Int1XY	<input type="checkbox"/> Int2XY	<input type="checkbox"/>	

DSP1 to DSP6 are optional.

**Setting Cycle Statistical Processing**

1. Press **MEASURE**.
2. Press the **Mode** soft key to select **Cycle Statistics**.
3. Press the **Item Setup** soft key. The measurement parameter dialog box and the measurement channel menu appear.
4. Press the **Trace** soft key and use the **jog shuttle** and **SELECT** to select the measurement channel.
5. Turn the **jog shuttle** to move the cursor to the parameter you wish to turn ON.
6. Press **SELECT** to turn on the parameter selected in step 5.  
You can turn OFF all parameters at once by pressing the **All Clear**. You can copy the current parameter settings to all traces by selecting “**Copy to All Trace.**”
7. Repeat steps 4 to 6 as many times as necessary. Press **ESC**.
8. Press the **Cycle Trace** soft key. The cycle trace menu appears.
9. Press the soft key corresponding to the channel to be used to determine the cycle. If Own is specified, the cycle is determined on each waveform for statistical processing.

The setting of other parameters is the same as the automated measurement of waveform parameters (see step 19 and following steps in section 11.6).

**Executing Statistical Processing**

10. Press the **Measure Exec** soft key. Statistical processing is executed. Press the same key again to abort.  
Proceed to step 11.

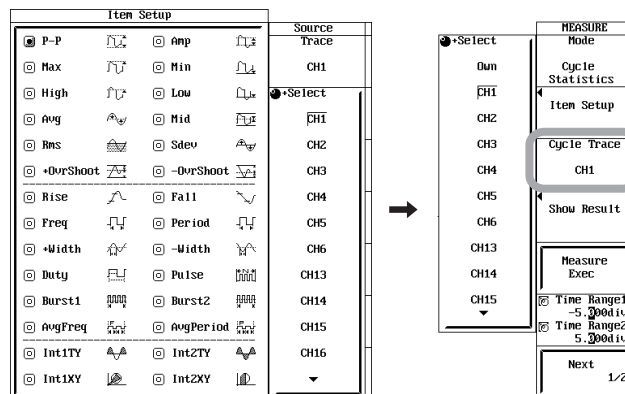
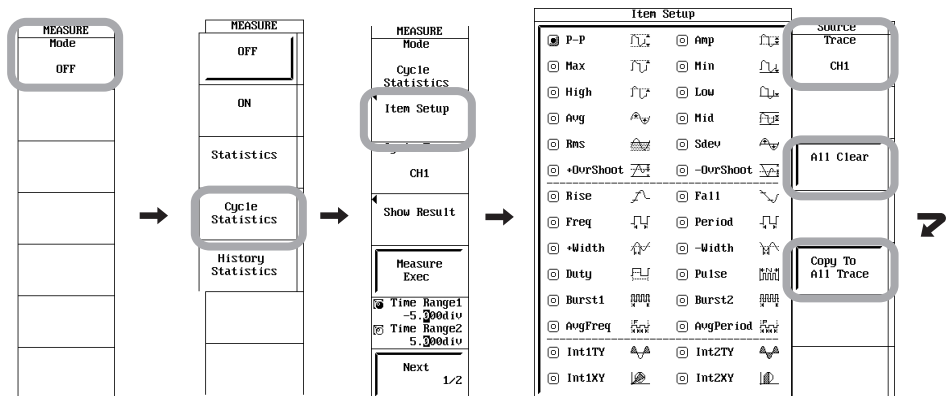

DSP1 to DSP6 are optional.

## 11.7 Performing Statistical Processing

### Setting Statistical Processing of History Data

1. Press **MEASURE**.
2. Press the **Mode** soft key to select History Statistics.
3. Press the **Item Setup** soft key. The measurement parameter dialog box and the measurement channel menu appear.
4. Press the **Trace** soft key and use the **jog shuttle** and **SELECT** to select the measurement channel.
5. Turn the **jog shuttle** to move the cursor to the parameter you wish to turn ON.
6. Press **SELECT** to turn on the parameter selected in step 5.  
You can turn OFF all parameters at once by pressing the **All Clear**. You can copy the current parameter settings to all traces by selecting "**Copy to All Trace.**"
7. Repeat steps 4 to 6 as many times as necessary. Press **ESC**.

The setting of other parameters is the same as the automated measurement of waveform parameters (see step 8 and following steps in section 11.6).

### Executing Statistical Processing

8. Press the **Measure Exec** soft key. Statistical processing is executed. Press the same key again to abort.  
Proceed to step 11.

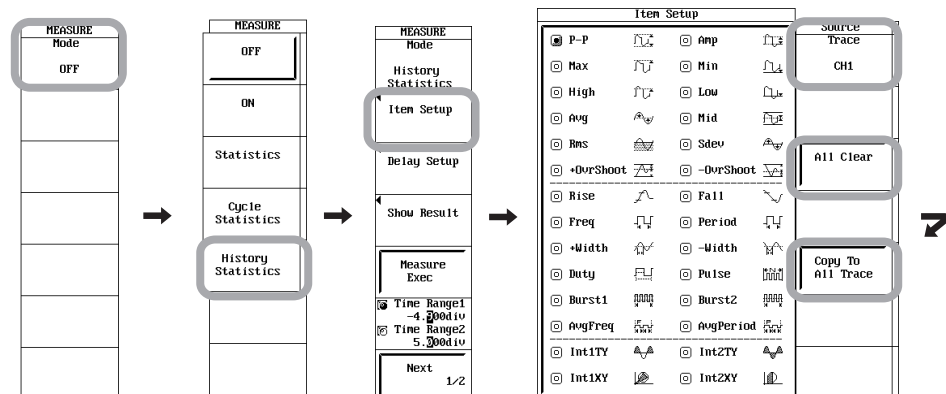

Item Setup		Source Trace
<input checked="" type="checkbox"/> P-P	<input type="checkbox"/> Amp	CH1
<input type="checkbox"/> Max	<input type="checkbox"/> Min	<b>Select</b>
<input type="checkbox"/> High	<input type="checkbox"/> Low	CH1
<input type="checkbox"/> Avg	<input type="checkbox"/> Mid	CH2
<input type="checkbox"/> Rms	<input type="checkbox"/> Sdev	CH3
<input type="checkbox"/> +OvrShoot	<input type="checkbox"/> -OvrShoot	CH4
<input type="checkbox"/> Rise	<input type="checkbox"/> Fall	CH5
<input type="checkbox"/> Freq	<input type="checkbox"/> Period	CH6
<input type="checkbox"/> +Width	<input type="checkbox"/> -Width	CH13
<input type="checkbox"/> Duty	<input type="checkbox"/> Pulse	CH14
<input type="checkbox"/> Burst1	<input type="checkbox"/> Burst2	CH15
<input type="checkbox"/> AvgFreq	<input type="checkbox"/> AvgPeriod	CH16
<input type="checkbox"/> Int1TY	<input type="checkbox"/> Int2TY	
<input type="checkbox"/> Int1XY	<input type="checkbox"/> Int2XY	

DSP1 to DSP6 are optional.

**Displaying the Results of Statistical Processing**

- Press the **Show Result** soft key to display a list of the results of statistical processing. Press the arrow key to scroll the list horizontally. Turn the jog shuttle to scroll the list vertically. Press the Max/Min Item1 to Max/Min Item6 soft keys to move the cursor to the maximum and minimum values of each waveform parameter. The displayed parameters from the left end correspond to Item1, Item2, Item3, Item4, Item5, and Item6. You can press the Sort soft key to sort the list in ascending (FWD) or descending (REV) order.

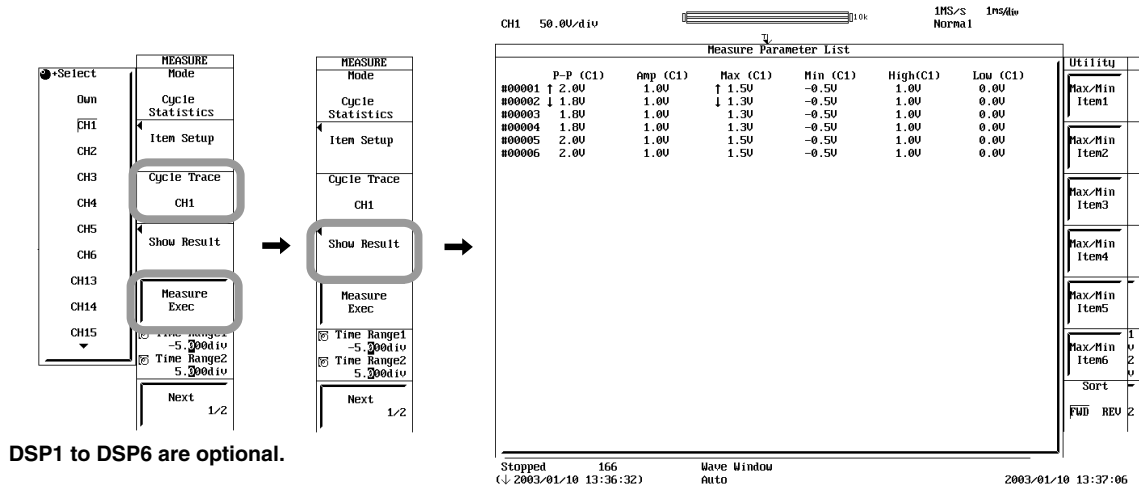

**Explanation**

Statistical processing is performed on the same measurement parameters as those of the automated measurement of waveform parameters. The following five statistics are determined on the three measured values of automated measurement parameters.

- Max: Maximum value
- Min: Minimum value
- Avg: Average value
- Sdv: Standard deviation
- Cnt: Number of measured values used in the statistical processing

For example, if you selected P-P of CH1 as an automated measurement parameter, the maximum, minimum, average, standard deviation, and the number of measured values used in the statistical processing are displayed at the bottom section of the screen.

The result of statistical processing that can be displayed is three parameters of automated measurement. If you selected four or more parameters for automated measurement, the first three parameters in the automated measurement parameter selection menu (P-P, Amp, Max, Min, \*, Init1XY, and Init2XY) of Item Setup are displayed in order from the smallest channel.

Example 1: When CH1: P-P, Amp; CH2: Min; and CH3: Max, Min are selected  
CH1: P-P, CH2: Min, and CH3: Max are displayed.

Example 2: If CH1: Max, Min and CH2: P-P and Amp are selected  
CH1: Max, Mix, and CH2: P-P are displayed.

The results of statistical processing that are not displayed can be loaded in the following manner.

- Load the results into your PC using the communication function.
- Save the results of statistical processing as measured values of automated measurement parameters (see section 13.10) and load the values into your PC.
- Scroll the list of statistical processing results using the arrow keys.

Statistical processing includes three types: normal statistical processing, cycle statistical processing, and statistical processing of history data.

**Normal Statistical Processing (Statistics)**

Statistical processing is performed on all acquired waveforms while acquiring waveforms. If you stop waveform acquisition and start it again, statistical processing continues from the statistical processing result obtained up to the previous stop. Statistical processing is performed on the selected parameters for automated measurement that are not displayed. Therefore, if you disable the statistical processing of a displayed automated measurement parameter while waveform acquisition is in progress, the statistical processing results of the next selected automated measurement parameter in line to be displayed are displayed. The number of measured values used in the statistical processing (Cnt) is the number of waveforms that have been acquired up to that point.

If you add statistical processing on a new automated measurement parameter while waveform acquisition is in progress or when it is stopped, the number of measured values used in the statistical processing (Cnt) is the number of waveforms that have been acquired since the parameter was added.

**Cycle Statistical Processing**

The cycle of the displayed waveform is determined in order from the oldest data, the selected parameters for automated measurement are measured on the data within the cycle, and statistical processing is performed. The cycle is determined in the same fashion as the Period for the waveform parameter. You can select whether to apply the cycle of the specified waveform to all waveforms or determine the cycle for each waveform.

- CH, Math, DSP: Performs automated measurement of waveform parameters on all target waveforms per cycle of the specified channel, and performs statistical processing.
- Own: Determines the cycle for each target waveform, performs automated measurement of waveform parameters for each cycle, and performs statistical processing. However, if signals of different cycles are applied to multiple channels, automated measurement of waveform parameters and statistical processing are performed for the number of cycles of the channel whose cycle is the slowest on all other channels.

**When Own is selected as the waveform used to determine the cycle**

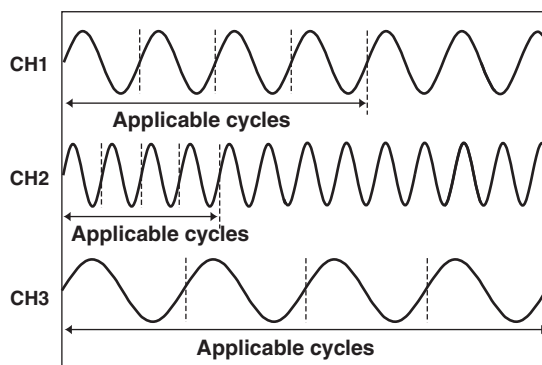

In the left figure, the number of cycles of the channel whose cycle is the slowest (CH3) is 4. Therefore, statistical processing is performed on the 4 oldest cycles of data for CH1 and CH2, also. The rest of the data is not used in statistical processing.

Statistical processing is performed from the oldest data of the displayed waveform in blocks of cycles.

It can not be used with the 1 cycle mode at the same time.

In addition, the following waveform parameters are not measured:

- For waveforms on which the cycle is measured: Avg Freq (average frequency), Avg Period (average period), PlsN (pulse count), Int1XY (area), Int2XY (area), and Delay.
- For other waveforms: Int1XY (area), Int2XY (area), and Delay.

**Statistical Processing of History Data**

Performs automated measurement of waveform parameters on the waveform that is acquired using the history memory function and performs statistical processing. Statistical processing is performed from the oldest waveform. The range on which the statistics are measured is the waveform that is displayed on Show Map. It can be used with Delay and 1 cycle mode.

**Target Waveforms**

CH1 to CH16, DSP1 to DSP6 (optional), and Math1 to Math8  
However, Math1 to Math8 are not applicable for statistical processing of history data.

**Automated Measurement Parameters for Statistical Processing**

The parameters on which statistical processing is performed are the parameters of automated measurement of waveform parameters in section 11.6. The result of statistical processing that can be displayed is only three parameters of automated measurement.

**Measurement Range for Statistical Processing**

The measurement range is the same as that specified for automated measurement of waveform parameters (see section 11.6).

**Show Results**

If you perform cycle statistical processing or statistical processing of history data, a list of measured results can be displayed for the selected automated measurement parameters. The waveforms are numbered from the oldest cycle data or history data, and the corresponding results of automated measurement are displayed. The maximum and minimum values of each waveform parameter are displayed using ↑ (maximum) and ↓ (minimum). If there are multiple points that are of the same value, the maximum and minimum values are marked on the oldest data. The number of data points that can be listed is 48000. If this value is exceeded, the most recent 48000 points of automated measurement parameters of history waveforms or data are displayed. In this case, the maximum and minimum values may exist outside the displayed list. In such case, ↑ (maximum) and ↓ (minimum) that are outside the range are not displayed.

In statistical processing of history data, you can select a waveform using the jog shuttle and press SELECT to display the selected historical waveform.

In cycle statistical processing, you can select a number using the jog shuttle and press SELECT to zoom in on the waveform (1 cycle) of the selected number. Statistical processing is performed only on the data that can be listed.

**Notes When Performing Statistical Processing**

- While statistical processing is in progress,  is indicated at the upper left corner of the screen. All soft keys except the Measure Abort soft key are disabled.
- Statistical processing is not possible in the following cases.
  - Realtime recorded waveforms
  - FFT waveforms
  - The number of data points in the measurement range (see section 11.6) is greater than or equal to 10 Mpoints.
- Depending on the conditions such as the record length, the number of parameters on which statistical processing is performed, and the input waveform, the execution or termination (aborting) may take an extended time.

# 11.8 Performing GO/NO-GO Determination Using Zones

<For a description of this function, refer to page 2-58.>

## Procedure

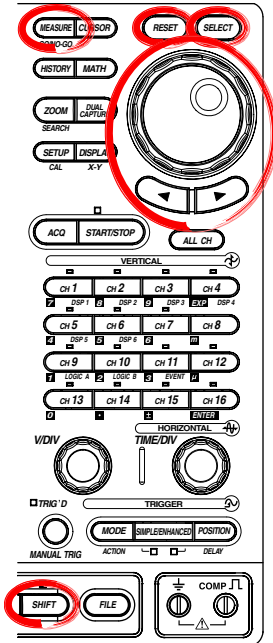

### Setting GO/NO-GO Determination Mode

1. Press **SHIFT+MEASURE**.
2. Press the **Mode** soft key. A menu for setting GO/NO-GO determination mode appears.
3. Press the **Zone** soft key.

### Creating a New Determination Zone

4. Press the **Edit Zone** soft key.
5. Press any of the **Zone1** to **Zone6** soft keys to select the Zone.
6. Press the **New** soft key. A menu for selecting the reference waveform for creating the zone appears.
7. Press the soft key corresponding to the reference waveform. The zone edit menu appears.

### Editing the Entire Zone

8. If Edit is not set to Whole, press the **Edit** soft key to select Whole.
9. Press the **Upper/Lower** or **Left/Right** soft key to select the direction to set the zone.
10. Turn the **jog shuttle** to create the zone.
11. Repeat steps 9 and 10 to edit the zone.
12. Press the **Store as** soft key to open a menu used to set the destination for registering the new zone.
13. Press the soft key corresponding to the destination from Zone1 to Zone6.
14. Press the **Store Exec** soft key to confirm the registration.

Proceed to step 15 to edit a section of the zone. Proceed to step 23 to finish the creation the zone.

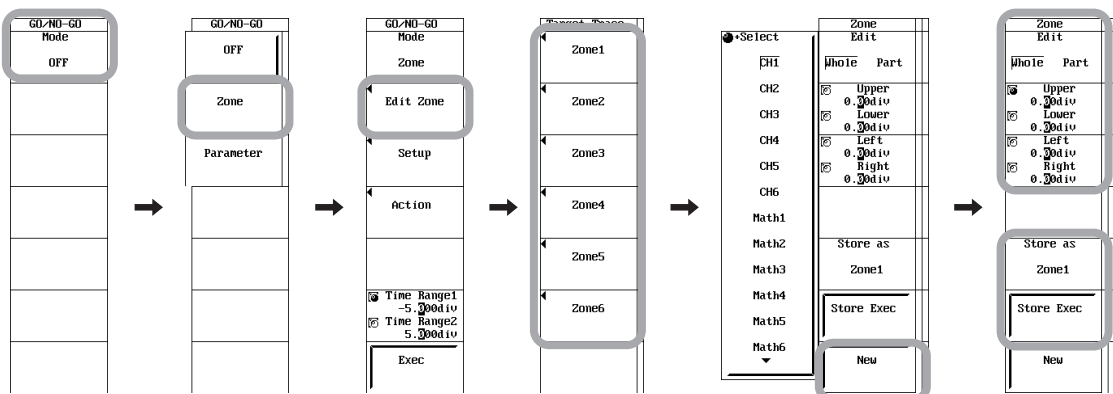

DSP1 to DSP6 are optional.

**Editing a Section of the Zone**

15. Press the **Edit** soft key to select Part.
16. Press the **Time Range1/Time Range2** soft key to select the right cursor or left cursor.
17. Turn the **jog shuttle** to set the right or left edge of the partial zone.
18. Press the **Upper/Lower** soft key to select the direction in which to set the zone. Then, turn the **jog shuttle** to create the zone.
19. Repeat steps 16 to 18 to create the desired zone.
20. Press the **Store as** soft key to open a menu used to set the destination for registering the new zone.
21. Press any of the **Zone1 to Zone6** soft keys to select the destination for registering the zone.
22. Press the **Store Exec** soft key to confirm the registration.

**Correcting a Preexisting Determination Zone**

23. Select the determination zone you wish to correct according to steps 4 and 5.
24. Correct the zone according to steps 8 to 22.

**Setting the Determination Waveform**

25. Press the **ESC** or carry out an equivalent operation to return to the GO/NO-GO menu.
  26. Press the **Setup** soft key. The setup menu appears.
- **Selecting the Trace**
    27. Use the **jog shuttle** and **SELECT** to set Trace of number 1.
  - **Selecting the Determination Criteria**
    28. Use the **jog shuttle** and **SELECT** to set Mode of number 1 to OFF, OUT, or IN.
  - **Selecting the Zone Number**
    29. Use the **jog shuttle** and **SELECT** to select ZoneNo. of number 1 from Zone1 to Zone6.
    30. As necessary, set items 2 to 16.

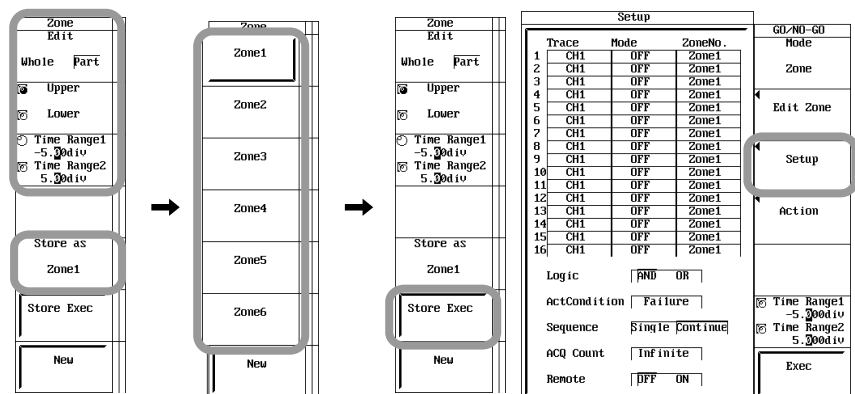



## 11.8 Performing GO/NO-GO Determination Using Zones

- **Setting the Logic**
  31. Use the **jog shuttle** and **SELECT** to set Logic to AND or OR.
- **Setting the Action Condition**
  32. Use the **jog shuttle** and **SELECT** to set ActCondition to Always, Failure, or Success.
- **Setting the Number of Actions**
  33. Use the **jog shuttle** and **SELECT** to set Sequence to Single or Continue.
- **Setting the Acquisition Count**
  34. Use the **jog shuttle** and **SELECT** to set ACQ Count.
- **Enabling/Disabling the External Input Signal**
  35. Use the **jog shuttle** and **SELECT** to set Remote to OFF or ON.

### Selecting the Action

36. Press the **Action** soft key.
37. Use the **jog shuttle** and **SELECT** to set each action ON/OFF.
38. If you turn ON Save to File in step 37, use the **jog shuttle** and **SELECT** to set the file save format to Binary, ASCII, or Float.

### Setting the Determination Range







39. Press the **Time Range1/Time Range2** soft key to set the jog shuttle control to Time Range1.
40. Turn the **jog shuttle** to set the determination start point.
41. Likewise, set Time Range2 (determination end point).

### Executing the GO/NO-GO Determination

42. Press the **Exec** soft key to execute the GO/NO-GO determination. The soft key changes to **Abort**. Waveform acquisition stops automatically, when determination is finished,

To stop the GO/NO-GO determination, press the **Abort** soft key or **START/STOP**.

In addition, if the following action is specified, the following icon is displayed at the upper left corner of the screen when an action is activated.

Image/Save to File: Save destination medium (  FD,  Zip disk,  PC card,  external SCSI device,  internal HD,  network drive, or  USB storage device)

Send Mail: 

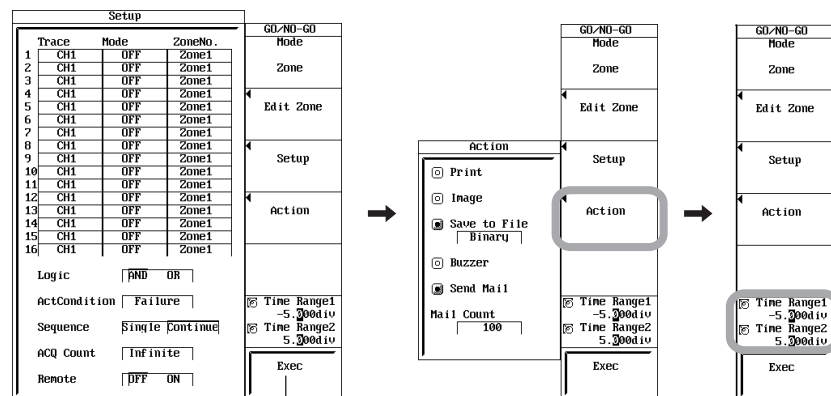

If Remote is set to ON,  
Exec (One Shot) is displayed.

**Explanation**

GO/NO-GO is determined by creating a zone based on a reference waveform and checking whether or not the waveform has left or entered the zone.

**Selecting the Reference Waveform: Edit Zone**

Select the reference waveform used to create the determination zone. You can select any of the following waveforms, that are displayed as a trace, as the reference waveform. CH1 to CH16, DSP1 to DSP6 (optional), Math1 to Math8

**Creating the Determination Zone**

You can specify up to 6 determination zones. The selectable range is as follows:

- Vertical range:  $\pm 10$  divisions from the reference waveform
- Horizontal range:  $\pm 5$  divisions from the screen center

You can select input signal waveforms (CH1 to CH16), computed waveforms (Math1 to Math8), and DSP channel waveforms (DSP1 to DSP6, optional) for the waveforms that are to be determined in the determination zones that are registered in Zone1 through Zone6.

The zones that are enabled through Setup are displayed on the screen.

**Note**

Match the input type of the target waveform to the reference waveform that was used when the zone was created.

For example, if the reference waveform was created from a "voltage input waveform," set the target waveform to "voltage input waveform." Correct determination cannot be made if the target waveform is set to "strain" or "temperature."

**Setting the Determination Conditions: Setup**

- **Selecting the Target Waveform: Trace**

Select the waveform from CH1 to CH16 and Math waveforms.

- **Setting the Determination Mode**

IN: GO condition when all the applicable waveforms enter the determination zone. NO-GO if any of the waveforms exists the determination zone.

OUT: GO condition when all the applicable waveforms are outside the determination zone. NO-GO if any of the waveforms enters the determination zone.

OFF: Does not perform GO/NO-GO determination.

- **Zone Number: ZoneNo.**

Select the zone number from Zone1 to Zone6.

- **Setting the Logic**

AND: Executes the action when all conditions (1 to 16 types) are met.

OR: Executes the Action when any one of the conditions (1 to 16 types) is met.

- **Action Condition: ActCondition**

Always: Always executes the action.

Failure: Execute the action when the GO condition is not met.

Success: Execute the action when the GO condition is met.

When Always is selected, the operation specified by Action is executed each time the trigger occurs. This function is useful such as when you wish to print the screen image data to a printer each time the trigger occurs.

- **Setting the Number of Actions: Sequence**

Single: Performs the action once.

Continue: Repeats the action up to acquisition count specified by ACQ Count. (If the count is set to Infinite, the action is repeated until the waveform acquisition is stopped.)

## 11.8 Performing GO/NO-GO Determination Using Zones

---

- **Setting the Number of Waveform Acquisitions: ACQ Count**

Set the number of waveform acquisitions.

Infinite: Continues until the waveform acquisition is stopped using the Abort soft key or START/STOP.

1 to 65536: Stops when the specified number of waveforms is acquired.

- **GO/NO-GO Determination Using an External Input Signal: Remote**

GO/NO-GO determination can be performed by synchronizing to an external signal applied to the GO/NO-GO I/O terminal. The determination result can also be output externally. Remote must be turned ON in order to perform GO/NO-GO determination using an external signal.

**Note**

---

Snapshot cannot be executed when GO/NO-GO determination using waveform zone is in progress.

---

**Action: Set Action**

The following five types of actions can be executed when the condition is met.

- **Print the Screen Image Data: PRINT**

Prints the screen image data on the printer (Printer (built-in printer), USB (USB printer), Net Print (network printer)) specified by Print to in the PRINT menu.

- **Save the Screen Image Data: Image**

Saves the screen image data to the destination (FD, Zip disk, PC card, internal HD (optional), SCSI device, or USB storage device) specified in the IMAGE SAVE menu.

- **Save the Waveform Data: Save to File**

Saves the waveform data in binary, ASCII, or floating format to the destination (FD, Zip disk, PC card, internal HD (optional), SCSI device, USB storage device) specified in the FILE menu. The save format is synchronized to data type (see section 13.7) on the FILE menu.

- **Buzzer**

Sounds a buzzer.

- **Send Mail**

Sends an e-mail message to a specified address. (when the Ethernet interface option is installed)

For the procedure in setting the address, see section 16.5, "Sending Period Mail or Action Mail."

**Setting the Determination Range (Time Range1/Time Range2)**

By default, the determination range is  $\pm 5$  divisions of the display frame on the time axis. You can limit this range. The concept of the determination range is analogous to the concept of the selectable range of cursor display position in cursor measurement. For details, see section 11.5, "Selectable Range of Cursor Position."

**Executing/Aborting GO/NO-GO Determination**

The operation starts when you press the Exec soft key. Waveform acquisition is automatically stopped when the determination is complete. To forcibly stop the operation, press START/STOP or the Abort soft key.

If Remote is turned ON, determination is executed using the input from the external terminal. To forcibly stop the operation, press START/STOP.

Pressing the Exec (One Shot) soft key executes the same operation as the input from the external terminal.

**Save to File/PRINT/Image Operation**

Operation is carried out according to the settings of FILE, PRINT, and IMAGE SAVE.

### File Name When Action Is Set to Save to File or Image

The file is saved using Numbering under the File menu or the Image Save menu.

For details, see section 13.11, "Saving the Screen Image Data" or section 13.7, "Saving/Loading Waveform Data."

### Notes When Performing GO/NO-GO Determination

- The determination results (the number of determinations and failures) are displayed.

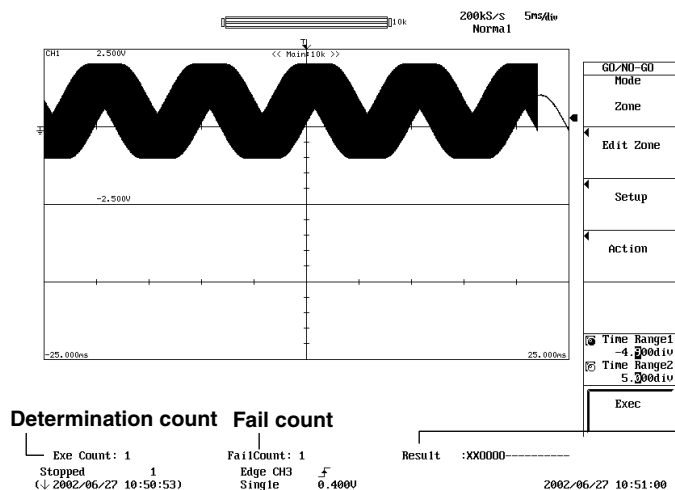

Indicates whether the condition of each determination waveform 1 to 16 is met.

XX0000-----

1,2,3, . . . . . ,16: Determination waveform

O: The specified condition is met

X: The specified condition is not met

-: Determination waveform for which a condition is not specified

In this example, the condition of determination waveform 1 is not met and the condition of determination waveform 3 is met.

- All keys other than START/STOP and the Abort soft key are disabled during the determination. (When Remote is ON, the Exec (One Shot) soft key is also valid.)
- When GO/NO-GO determination is executed, the trigger mode is automatically changed to Single.
- Determination is not possible when the acquisition mode is set to Average.
- Determination is not possible when realtime recording is in progress or when waveforms are being acquired using the dual capture function.
- If any of the following actions is activated while the DL750/DL750P is being accessed through the FTP server function or the Web server function, the action is not executed until the access is finished.
  - Printing/saving of the screen image data and saving of the waveform data

### Notes When Action Is Set to Save to File or Image Save

- Do not specify the root directory of the medium as the save destination directory. (Only up to 512 files can be saved to the root directory of a medium that has been formatted using the DL750/DL750P.)
- The maximum number of files that can be created in a single directory is 5000. Do not place files in the save destination folder before starting GO/NO-GO determination.
- If you select Save to File and Image Save simultaneously, separate the folders specified by the FILE menu and the IMAGE SAVE menu.
- If you selected Numbering for the file name assignment method (Auto Naming) in the FILE menu and the IMAGE SAVE menu, the creation of files takes an extended period when the number of saved files becomes large. When creating more than 2000 files, select Date for Auto Naming.

### Note

The zone waveforms you create can be stored as setup data on a storage medium such as a floppy disk, Zip disk, PC card, or internal hard disk (optional).

# 11.9 GO/NO-GO Determination Using Measured Waveform Parameters

<For a description of this function, refer to page 2-58.>

## Procedure

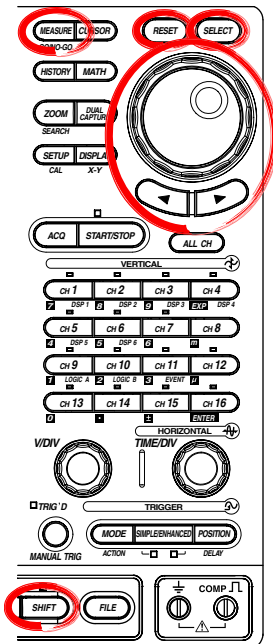

### Setting GO/NO-GO Determination Mode

1. Press **SHIFT+MEASURE**.
2. Press the **Mode** soft key. A menu for setting GO/NO-GO determination mode appears.
3. Press the **Parameter** soft key.

### Setting the Determination Conditions

4. Press the **Setup** soft key. A criteria setup dialog box appears. Use the jog shuttle or arrow keys to move the cursor to the item you wish to set.
- **Selecting the Target Waveform**
    5. Use the **jog shuttle** and **SELECT** to set Trace of number 1.
  - **Selecting the Determination Criteria**
    6. Use the **jog shuttle** and **SELECT** to set Mode of number 1 to OFF, OUT, or IN.
  - **Selecting the Parameter**
    7. Use the **jog shuttle** and **SELECT** to select item of number 1 from P-P to Int2XY.
    8. As necessary, set items 2 to 16.
  - **Setting the Upper and Lower Limits**
    9. Use the **jog shuttle** and **SELECT** to set Upper of number 1.
    10. Likewise, set Lower of number 1.
  - **Setting the Logic**
    11. Use the **jog shuttle** and **SELECT** to set Logic to AND or OR.
  - **Setting the Action Condition**
    12. Use the **jog shuttle** and **SELECT** to set ActCondition to Always, Failure, or Success.

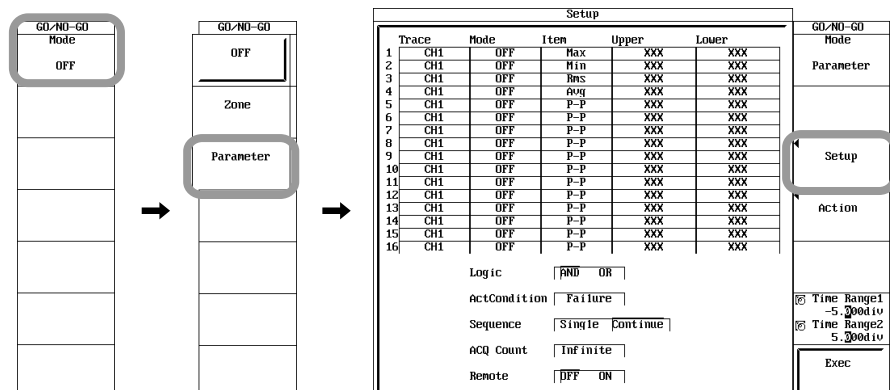

- **Setting the Number of Actions**
  13. Use the **jog shuttle** and **SELECT** to set Sequence to Single or Continue.
- **Setting the Number of Determinations**
  14. Use the **jog shuttle** and **SELECT** to set ACQ Count.
- **Enabling/Disabling the External Input Signal**
  15. Use the **jog shuttle** and **SELECT** to set Remote to OFF or ON.

**Selecting the Action**

16. Press the **Action** soft key.
17. Use the **jog shuttle** and **SELECT** to set each action ON/OFF.
18. If you turn ON Save to File in step 17, use the **jog shuttle** and **SELECT** to set the file save format to Binary, ASCII, or Float.

**Setting the Determination Range**

19. Press the **Time Range1/Time Range2** soft key to set the jog shuttle control to Time Range1.
20. Turn the **jog shuttle** to set the determination start point.
21. Likewise, set Time Range2 (determination end point).

**Executing the GO/NO-GO Determination**

22. Press the **Exec** soft key to execute the GO/NO-GO determination. The soft key changes to **Abort**. Waveform acquisition stops automatically, when determination is finished, To stop the GO/NO-GO determination, press the **Abort** soft key or **START/STOP**.

In addition, if the following action is specified, the following icon is displayed at the upper left corner of the screen when an action is activated.

Image/Save to File: Save destination medium ( FD, Zip disk, PC card, external SCSI device, internal HD, network drive, or USB storage device)

Send Mail:

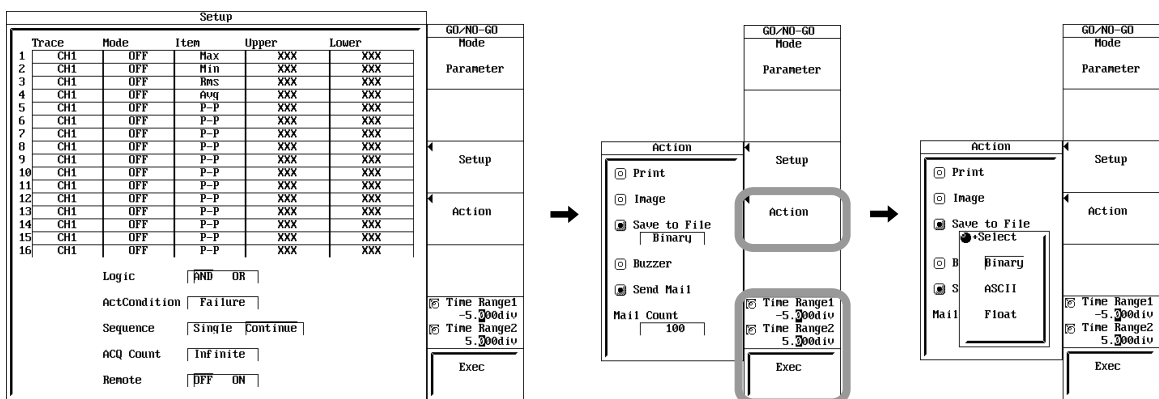

### **Explanation**

By setting the upper/lower limits of the automated measurement of waveform parameters, GO/NO-GO determination is performed on whether the measured value enters the range or exits the range.

#### **Setting the Determination Conditions: Setup**

- **Selecting the Target Waveform: Trace**  
Select the waveform from CH1 to CH16, DSP1 to DSP6 (optional), and Math waveforms.
- **Setting the Determination Mode**  
OFF: Does not perform GO/NO-GO determination.  
IN: Go condition when the value enters the specified upper and lower limits.  
OUT: Go condition when the value exits from the specified upper and lower limits.
- **Selecting the Parameter: Item**  
The waveform parameters that can be used are all the items of automated measurement of waveform parameters (28 types) given in section 11.6. Up to 16 types of parameters can be determined simultaneously.
- **Setting the Upper and Lower Limits of Parameters**  
The upper and lower limits vary depending on the parameters. They can be set in the range  $-9.9999E+30$  to  $9.9999E+30$ .
- **Setting the Logic**  
AND: Executes the action when all parameter conditions (1 to 16 types) are met.  
OR: Executes the action when any one of the parameter conditions (1 to 16 types) is met.
- **Action Condition: ActCondition**  
Always: Always executes the action.  
Failure: Execute the action when the GO condition is not met.  
Success: Execute the action when the GO condition is met.  
When Always is selected, the operation specified by Action is executed each time the trigger occurs. This function is useful such as when you wish to print the screen image data to a printer each time the trigger occurs.
- **Setting the Number of Actions: Sequence**  
Single: Performs the action once.  
Continue: Repeats the action up to acquisition count specified by ACQ Count. (If the count is set to Infinite, the action is repeated until the waveform acquisition is stopped.)
- **Setting the Number of Determinations: ACQ Count**  
Set the number of waveform acquisitions.  
Infinite: Continues until the waveform acquisition is stopped using the Abort soft key or START/STOP.  
1 to 65536: Stops when the specified number of waveforms is acquired.
- **GO/NO-GO Determination Using an External Input Signal: Remote**  
GO/NO-GO determination can be performed by synchronizing to an external signal applied to the GO/NO-GO I/O terminal. The determination result can also be output externally. Remote must be turned ON in order to perform GO/NO-GO determination using an external signal.

### Note

- The interval over which GO/NO-GO determination is performed is set using Time Range1 and Time Range2 in the GO/NO-GO menu. Other items follow the settings specified in the Measure menu.
- If you are not going to perform GO/NO-GO determination using an external signal, make sure to turn OFF Remote. Leaving it ON can cause instability in the start/stop operation of data acquisition using the START/STOP key

### Action: Set Action

The following five types of actions can be executed when the condition is met.

- **Print the Screen Image Data: PRINT**  
Prints the screen image data on the printer (Printer (built-in printer), USB (USB printer), or Net Print (network printer)) specified by Print to in the PRINT menu.
- **Save the Screen Image Data: Image**  
Saves the screen image data to the destination (FD, Zip disk, PC card, internal HD (optional), SCSI device, or USB storage device) specified in the IMAGE SAVE menu.
- **Save the Waveform Data: Save to File**  
Saves the waveform data in binary, ASCII, or floating format to the destination (FD, Zip disk, PC card, internal HD (optional), SCSI device, or USB storage device) specified in the FILE menu. The save format is synchronized to data type (see section 13.7) on the FILE menu.
- **Buzzer**  
Sounds a buzzer.
- **Send Mail**  
Sends an e-mail message to a specified address. (when the Ethernet interface option is installed)  
For the procedure in setting the address, see section 16.5, "Sending Periodic Mail or Action Mail."

### Setting the Determination Range (Time Range1/Time Range2)

By default, the determination range is  $\pm 5$  divisions of the display frame on the time axis. You can limit this range. The concept of the determination range is analogous to the concept of the selectable range of cursor display position in cursor measurement. For details, see section 11.5, "Selectable Range of Cursor Position."

### Executing/Aborting GO/NO-GO Determination

The operation starts when you press the Exec soft key. Waveform acquisition is automatically stopped when the determination is complete. To forcibly stop the operation, press START/STOP or the Abort soft key.

If Remote is turned ON, determination is executed using the input from the external terminal. To forcibly stop the operation, press START/STOP.

Pressing the Exec (One Shot) soft key executes the same operation as the input from the external terminal.

### Save to File/PRINT/Image Operation

Operation is carried out according to the settings of FILE, PRINT, and IMAGE SAVE.



## 11.9 GO/NO-GO Determination Using Measured Waveform Parameters

### File Name When Action Is Set to Save to File or Image

If the Auto Naming of the File menu or the Image Save menu is OFF, numbers are automatically assigned to the file names. Otherwise, the file is saved using the specified method.

For details, see section 13.11, "Saving the Screen Image Data" or section 13.7, "Saving/Loading Waveform Data."

### Notes When Performing GO/NO-GO Determination

- The determination results (the number of determinations and failures) are displayed.

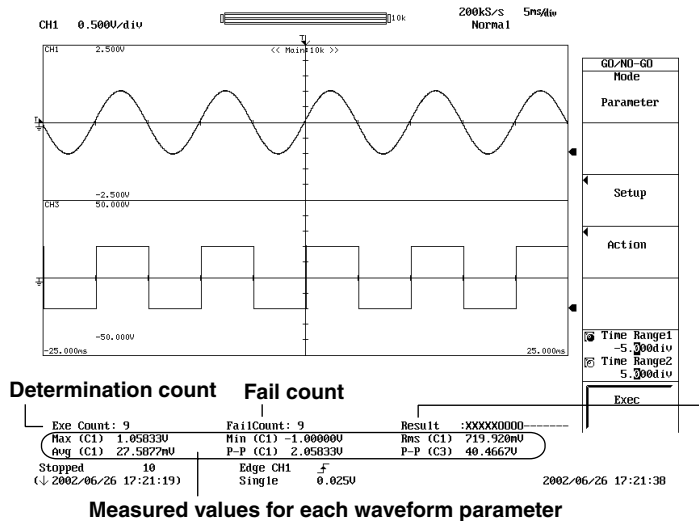

Indicates whether the condition of each waveform parameter 1 to 16 is met. Waveform parameters

XXXXX0000-----  
1,2,3,.....,16: waveform parameter

O: The specified condition is met  
X: The specified condition is not met  
-: Waveform parameter for which a condition is not specified

In this example, the condition of waveform parameter 1 is not met and the condition of waveform parameter 6 is met.

- All keys other than START/STOP and the Abort soft key are disabled during the determination. (When Remote is ON, the Exec (One Shot) soft key is also valid.)
- When GO/NO-GO determination is executed, the trigger mode is automatically changed to Single.
- Determination is not possible when the acquisition mode is set to Average.
- The determination period is synchronized to the trigger. (However, triggers are not accepted while the action after determination is being carried out.)
- Determination is not possible when realtime recording is in progress or when waveforms are being acquired using the dual capture function.
- If any of the following actions is activated while the DL750/DL750P is being accessed through the FTP server function or the Web server function, the action is not executed until the access is finished.
  - Printing/saving of the screen image data and saving of the waveform data

### Notes When Action Is Set to Save to File or Image Save

- Do not specify the root directory of the medium as the save destination directory. (Only up to 512 files can be saved to the root directory of a medium that has been formatted using the DL750/DL750P.)
- The maximum number of files that can be created in a single directory is 5000. Do not place files in the save destination folder before starting GO/NO-GO determination.
- If you select Save to File and Image Save simultaneously, separate the folders specified by the FILE menu and the IMAGE SAVE menu.
- If you selected Numbering for the file name assignment method (Auto Naming) in the FILE menu and the IMAGE SAVE menu, the creation of files takes an extended period when the number of saved files becomes large. When creating more than 2000 files, select Date for Auto Naming.

# 11.10 Using the GO/NO-GO Determination I/O Function

GO/NO-GO determination can be performed by applying an external signal to the GO/NO-GO I/O terminal of the DL750/DL750P. The determination result can also be output externally from the terminal.

## GO/NO-GO Determination I/O Terminal Connector

### Type

Modular jack (RJ-11). Use the optional accessory 366973 (sold separately) for the cable. If you are using a commercially sold cable (4 contact modular cable for telephone circuits), wire the pins according to the following figure.

### I/O Level

Within 0 to 5 V, threshold level: TTL

### Pin Arrangement

Pin No.	Signal Name		
1	NC (no connection)		
2	START IN	IN	Start at low
3	GO OUT	OUT	Active low
4	NOGO OUT	OUT	Active low
5	GND		
6	SPEAKER		

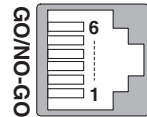

Connector on the DL

## Input Signal

### START IN (Negative Logic)

This signal is used when performing GO/NO-GO determination by synchronizing to an external input signal. The signal is valid only when “Remote” is ON. If “Remote” is OFF, GO/NO-GO determination is performed regardless of the external signal input (the GO/NO-GO determination result is output).

See below for the timing chart.

### Signal Input Circuit

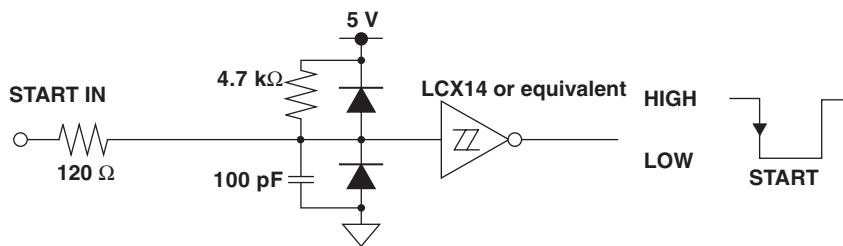

**Output Signal**

**NOGO OUT (Negative Logic)**

When the determination result is “NO-GO” (fail), the output signal level changes from high level to low level temporarily.

**GO OUT (Negative Logic)**

When the determination result is “GO” (pass), the output signal level changes from high level to low level temporarily.

**Signal Output Circuit**

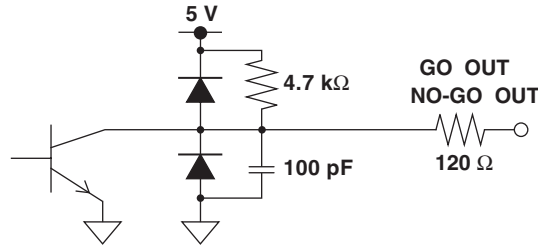

**GO/NO-GO I/O Timing**

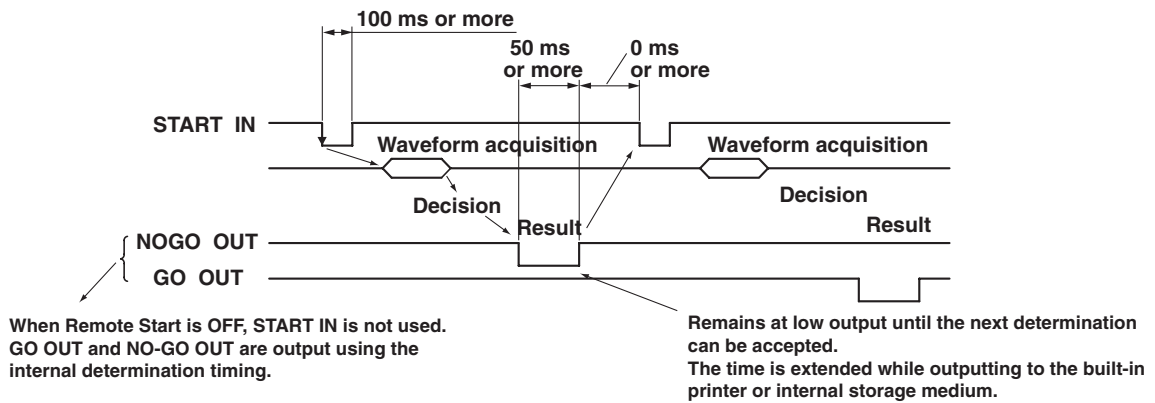

**GO/NO-GO Cable (366973, Sold Separately)**

- Use this cable only for the GO/NO-GO determination on the DL750/DL750P.
- See the following figure for the connection to external devices.

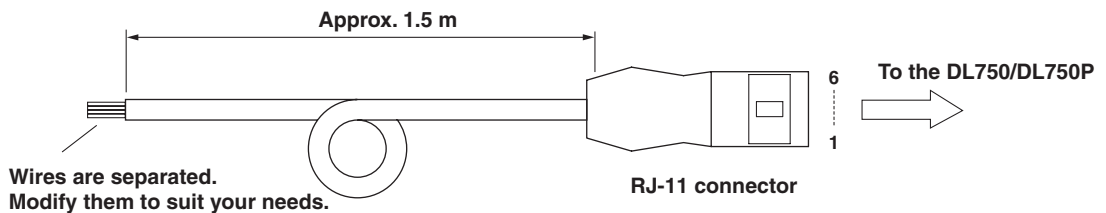

Color	Pin No.	Signal Name	Logic
Yellow	2	START IN	Negative
White	3	GO OUT	Negative
Green	4	NOGO OUT	Negative
Blue	5	GND	

## 12.1 Loading the Roll Paper and Paper Feeding

This section describes how to load the DL750 roll paper. For the procedure to load the DL750P roll paper, see section 9.1 in the User's Manual Part 1.

### Printer Roll Paper

Use only the YOKOGAWA's dedicated roll paper (for the DL750 and OR100E/OR300E). When you are using the printer for the first time, use the roll paper that came with the package. Order extra rolls from your nearest YOKOGAWA dealer.

Part No.: B9988AE  
Specifications: Thermal paper, 10 m  
Minimum Q'ty: 10 rolls

### Roll Paper Handling

The paper is a thermal paper that changes color with the application of heat. Take note of the following points.

#### Storage Precautions

The paper starts changing color at around 70° C. It is affected by heat, humidity, light, and chemicals regardless of whether the paper has been used.

- Store the paper rolls in a cool, dry, and dark place.
- After opening the package, use it quickly.
- If the paper is left in contact with plastic film (such as a vinyl chloride film or Scotch tape) containing plasticizers for an extended time, the paper will lose some of its ability to reproduce color. If you are going to store the paper in a folder, for example, use a folder made of polypropylene.
- When using glue on the paper, do not use glue containing organic solvents such as alcohol or ether, as they will change the color of the paper.
- For prolonged storage, we suggest you copy the roll paper. Due to the characteristics of the thermal paper, the recording section may lose color over time.

#### Handling Precautions

- Be sure to use only genuine paper rolls provided by YOKOGAWA.
- Touching the paper with sweaty hands can leave finger print marks or blur the printing.
- Rubbing the surface with a hard object can cause the paper to change color due to the heat caused by friction.
- If chemicals, oil, or other liquids come in contact with the paper, the paper may change color or the printing may fade.

### Loading the Roll Paper

#### Procedure

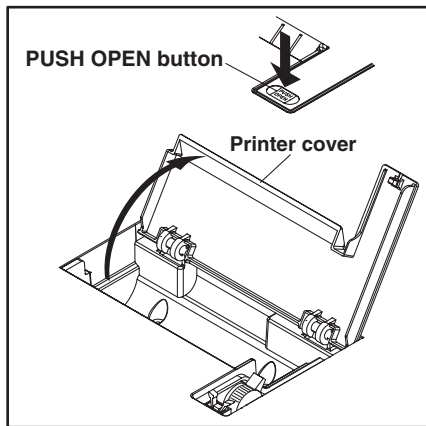

1. Press the PUSH OPEN button and remove the printer cover lock. Pull up on the handle located on the right side of the printer cover to open the cover.

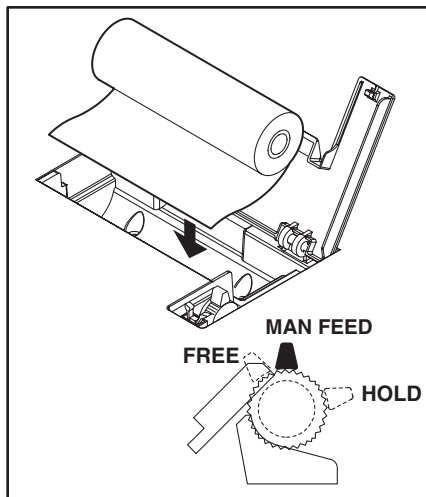

2. Move the release arm, located on the right near the front, to the MAN FEED position. Have the inner side of the roll paper (the side that is not glossy) showing on top and set to the holder.

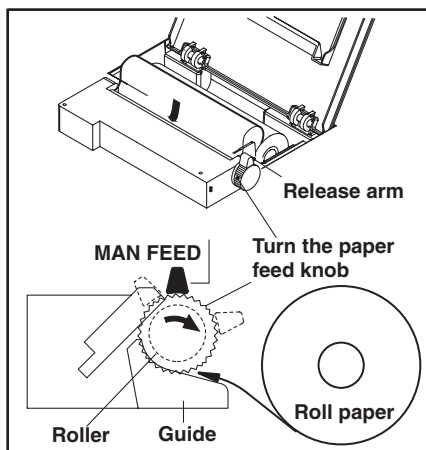

3. Insert the edge of the roll paper evenly in the space between the roller and the black guide, then rotate the paper feed knob away from you until about 10 cm of the paper is showing from the top of the roller.

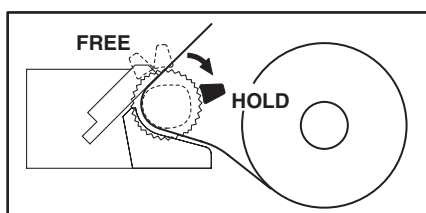

4. Move the release arm to the FREE position and straighten out the paper. Then, move the release arm to the HOLD position. The printing will fail with an error message, if the release arm is in the FREE or MAN FEED position during operation.

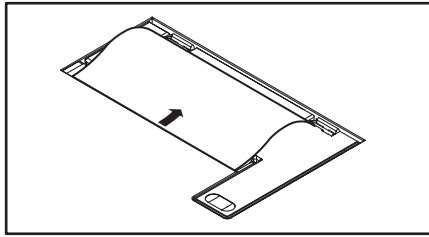

5. Pull the printer cover back to its original position and close the cover. Make sure that the edge of the roll paper is showing from the opening of the printer cover. Push the printer cover down firmly until it clicks into place.

**Note**

- When closing the printer cover, be sure to set the release arm position to HOLD.
- After installing the roll paper, make sure that the paper is feeding properly according to the steps given below. If the paper is not being fed evenly, continue to feed the paper for approximately 30 cm. The paper will straighten out.

**Feeding the Paper**

You can feed the paper to check whether the roll paper has been loaded properly or to skip dirty sections.

**Procedure**

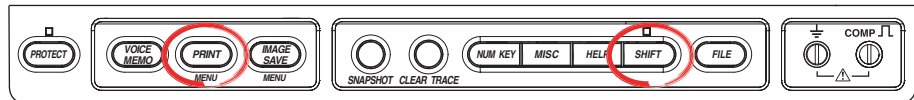

1. Press **SHIFT+PRINT**.
2. Press the **Print to** soft key. The printer selection menu appears. (Net Print appears only when the Ethernet interface option is installed.)
3. Press the **Printer** soft key.
4. Press the **Paper Feed** soft key to feed the paper.

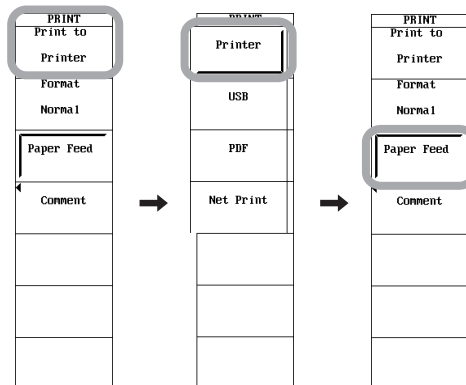

## 12.2 Printing on the Built-in Printer

<For a description of this function, refer to page 2-62.>

### Procedure

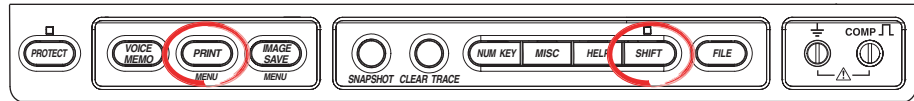

1. Press **SHIFT+PRINT**.

### Selecting the Printer

2. Press the **Print to** soft key. The printer selection menu appears. (Net Print appears only when the Ethernet interface option is installed.)
3. Press the **Printer** soft key.

### Setting the Output Format

4. Press the **Format** soft key. The output format selection menu appears.
5. Press the **Normal**, **Fine**, **Zoom Print**, or **A4 Print** soft key. A4 Print is displayed only on the DL750P.

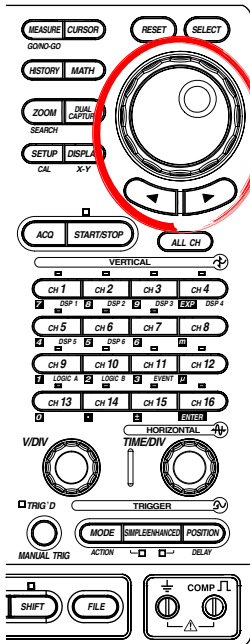

## Printing in Normal Output Format (When Normal Is Selected in Step 5)

### Setting a Comment

6. Press the **Comment** soft key.
7. Enter the comment string according to the procedure given in section 4.2. Proceed to step 29.

### Note

The comment setting is linked with the PRINT menu > Comment setting.

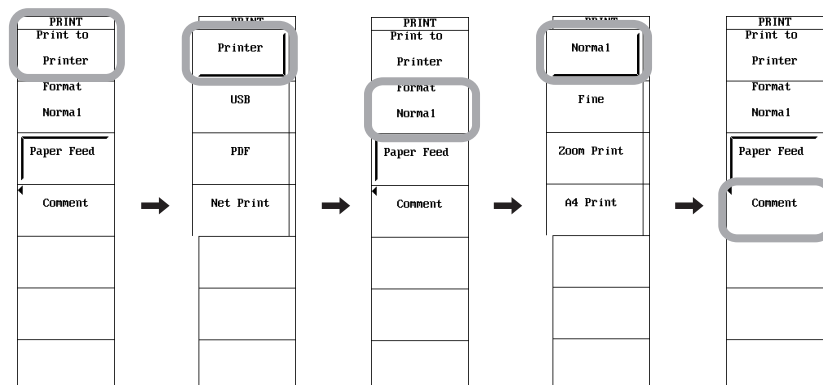

## Fine Print (When Fine Is Selected in Step 5)

### Setting the Print Magnification

- Press the **Print Mag** soft key, and use the **jog shuttle** to set the print magnification. The number of pages that will be printed is displayed according to the magnification.

### Setting the Print Range

- Press the **Time Range1/Time Range2** soft key to set the jog shuttle control to Time Range1.
- Use the **jog shuttle** and **SELECT** to set the print start point.
- Likewise, set Time Range2 (print end point). Proceed to step 10.

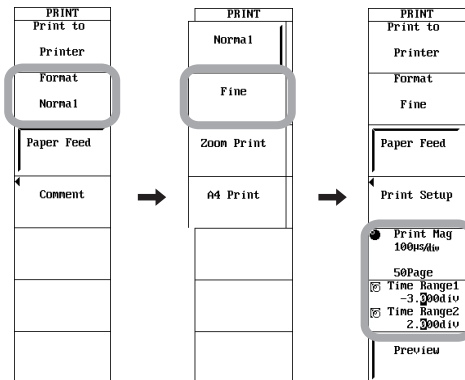

## Zoom Print (When Zoom Print Is Selected in Step 5)

### Setting Zoom Box Z2

- Press the **Z2 Mag/Z2 Position** soft key to set the jog shuttle control to Time Z2 Mag.
- Turn the **jog shuttle** to set the zoom rate of the Z2 zoom box.
- Likewise, set the zoom position of the Z2 zoom box with Z2 Position. Proceed to step 10.

### Note

- In zoom print, the range of zoom box Z2 (10 divisions) is printed.
- The Z2 Mag/Z2 Position setting is linked with the ZOOM menu (see section 8.5) setting.

### Setting the Print Magnification

- Press the **Print Mag** soft key, and use the **jog shuttle** to set the print magnification. The number of pages that will be printed is displayed according to the magnification. Proceed to step 10.

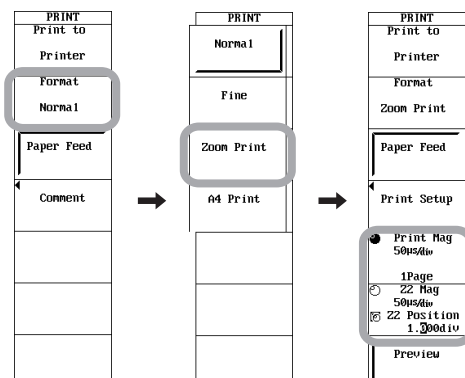



### A4 Print (When Fine Is Selected in Step 5)

Proceed to step 10.

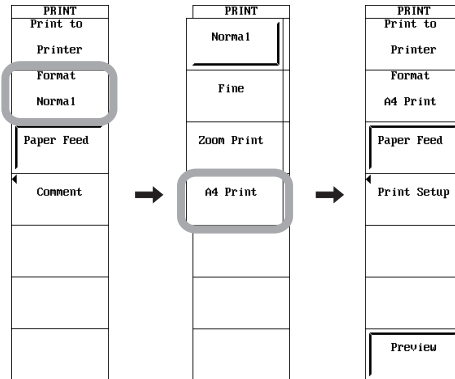

#### Specifying the Print Settings

- **DL750**
  10. Press the **Comment** soft key.
  11. Enter the comment text according to the procedure in section 4.2.  
Proceed to step 27.

#### Note

The comment setting is linked with the PRINT menu > Comment setting.

- **DL750P**
  10. Press the **Print Setup** soft key.

#### Setting the Print Format

11. Use the **jog shuttle** and **SELECT** to select Format from Single (1 division) to Hexadecimal (16 divisions).

#### Note

The print format setting is linked with the DISPLAY menu > Format setting.

#### Setting the Extra Area

12. Use the **jog shuttle** and **SELECT** to set **Extra Area** to ON or OFF.

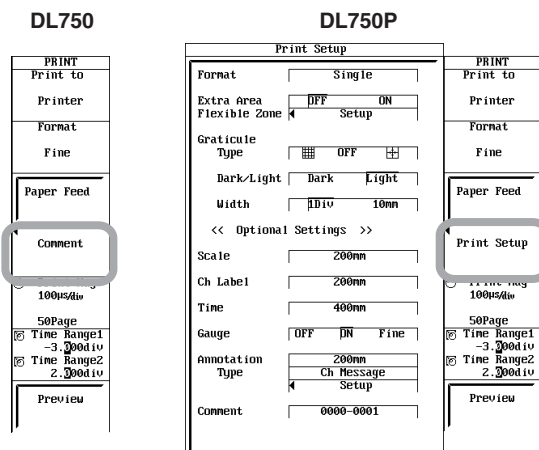

**Setting the Flexible Zone**

13. Use the **jog shuttle** and **SELECT** to select **Setup** in **Flexible Zone**.
14. Use the **jog shuttle** and **SELECT** to set Mode to OFF or ON.
15. Use the **jog shuttle** and **SELECT** to set Upper/Lower of the waveform to be recorded.

**Setting the Graticule**

• **Setting the Grid**

16. Use the **jog shuttle** and **SELECT** to set Type to , OFF, or .

• **Setting Dark/Light**

17. Use the **jog shuttle** and **SELECT** to set Dark/Light to Light or Dark.

• **Setting the Width of the Vertical Scale**

18. Use the **jog shuttle** and **SELECT** to set Width to 1div or 10mm.  
Proceed to step 19.

**Note**

The grid setting is linked with the DISPLAY menu > Graticule setting. However, if OFF is selected, the DISPLAY menu is set to .

**Setting Details**

**Setting the Print Interval of Scale Values**

19. Use the **jog shuttle** and **SELECT** to set Scale to OFF, 200mm, 400mm, or 800mm.

**Setting the Print Interval of Channel Labels**

20. Use the **jog shuttle** and **SELECT** to set CH Label to OFF, 200mm, 400mm, or 800mm.

**Setting Whether to Print the Time**

21. Use the **jog shuttle** and **SELECT** to set Time to OFF, 200mm, 400mm, or 800mm.

**Setting the Gauge Print**

22. Use the **jog shuttle** and **SELECT** to set Gauge to OFF, ON, or Fine.

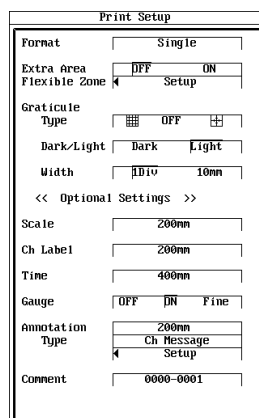

## 12.2 Printing on the Built-in Printer

### Setting the Annotation

23. Use the **jog shuttle** and **SELECT** to set the print interval of annotations in the right column of Annotation to OFF, 200mm, 400mm, or 800mm.
24. Use the **jog shuttle** and **SELECT** to set the type of annotation to be printed in the right column of Type to CH Information, CH Message, or CH Data.  
If CH Message is selected, proceed to step 25.  
If CH Information or CH Data is selected, proceed to step 26.
25. Use the **jog shuttle** and **SELECT** to select Setup. Then, enter the message you wish to print for the channel using up to 80 characters according to the procedure in section 4.2.

### Setting a Comment

26. Use the **jog shuttle** and **SELECT** to select Comment. Then, enter the comment text you wish to print using up to 20 characters according to the procedure in section 4.2.

### Note

The comment setting is linked with the PRINT menu > Comment setting.

Print Setup	
Format	Single
Extra Area	OFF
Flexible Zone	ON Setup
Graticule	OFF
Type	Bark Light
Bark/Light	Bark Light
Width	10mm
<< Optional Settings >>	
Scale	200mm
Ch Label	200mm
Time	400mm
Gauge	OFF ON Fine
Annotation	200mm
Type	CH Message Setup
Comment	0000-0001

### Previewing the Print Image

27. Press the **Preview** soft key. The print image is displayed on the screen.  
Turn the **jog shuttle** to change the displayed page.
28. Press the **Quit** soft key. The original display appears.

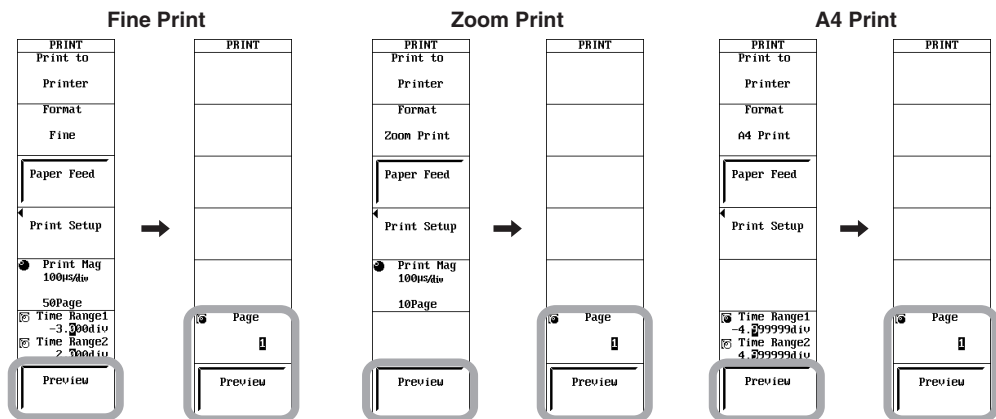

### Executing the Printing

29. Press **PRINT**. The screen image data is printed on the built-in printer.  
To abort printing, press **PRINT** while printing is in progress.  
While printing is in progress,  is indicated in the upper left corner of the screen.

**Explanation**

**Output Format: Format**

Select from three types: Normal, Fine, and Zoom Print.

**Normal**

Prints using normal size.

**Fine**

The print range on the waveform displayed on the screen (Time Range1 and Time Range2) is specified, and the print range is printed magnified.

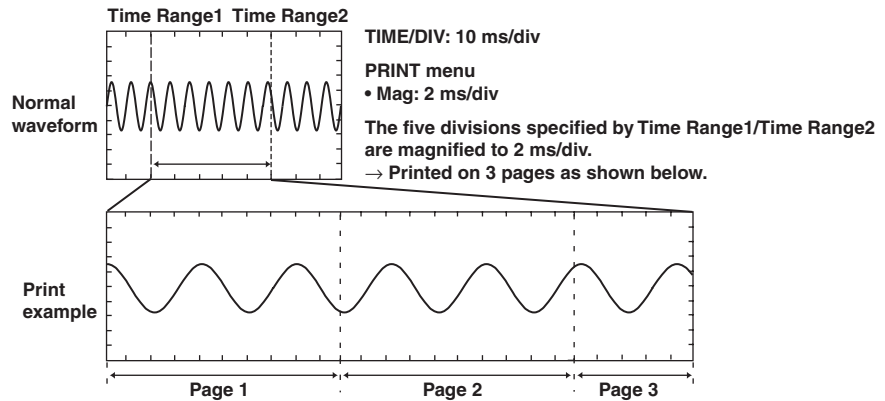

**Zoom Print**

The range of zoom box Z2 of the zoom function (see section 8.5) is magnified and printed.

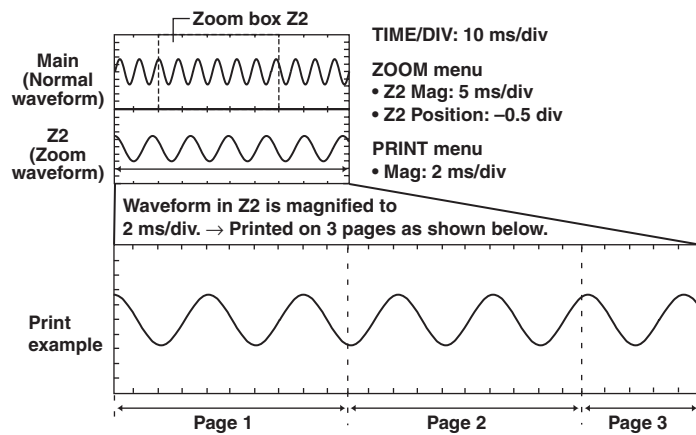

**A4 Print (DL750P Only)**

Prints the waveform displayed on the screen to an A4 size paper.

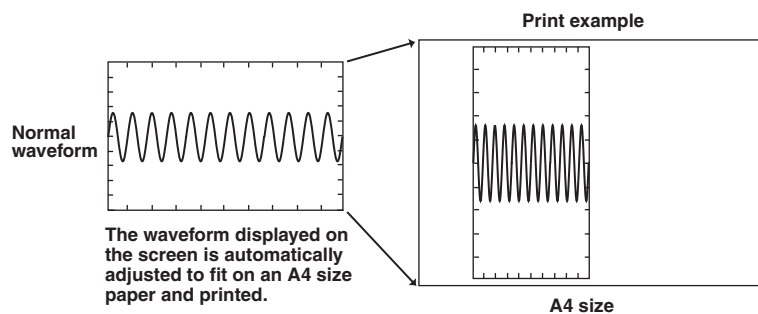

### Printing Using Normal Output Format

#### Comment

A comment string of up to 20 characters can be printed at the top section of the print area. The comment setting is linked with the PRINT menu > Comment setting.

### Fine Print, Zoom Print, and A4 Print

#### Print Magnification: Print Mag

Set the print magnification only during fine print and zoom print. The selectable range varies depending on the T/div setting and record length.

#### Print Range: Time Range1/Time Range2

Set the print range only during fine print. Set the print range in the range of -5 divisions to 5 divisions.

#### Zoom Box Z2: Z2 Mag/Z2 Position

Set zoom box Z2 only during zoom printing. The zoom box Z2 setting is linked to the ZOOM menu setting. For details such as the selectable range, see section 8.5.

#### Print Setup

##### **Format**

Select the number of divisions of the print area when printing on the built-in printer.

Single: 1 division	Quad: 4 divisions
Dual: 2 divisions	Octal: 8 divisions
Triad: 3 divisions	Hexadecimal: 16 divisions

The format setting is linked with the DISPLAY menu > Format setting.

##### **Extra Area**

The extra area can be set only when the format is set to Single, Dual, Triad, or Quad.

- **When the Format Is Single**

If extra area is turned ON, the top 16 cm of the print area (20 cm) is used to print waveforms, and the remaining 4 cm is used to print waveform information (extra area). Annotations (see the next page) and logic waveforms are printed in the extra area. The default setting is OFF.

- **When the Format is Dual, Triad, or Quad**

If extra area is turned ON, the area below each of the divided waveform recording area is used to print the waveform information (extra area). If extra area is turned OFF, the extra area between each waveform recording area disappears. The magnification of the vertical axis of each waveform recording area is adjusted automatically according to the paper size and printed. The default setting is ON.

**Flexible Zone**

The flexible zone can be set only when the format is Single and the extra area is OFF. The position in the print area (20 cm) where each waveform is to be recorded is set with Upper and Lower (%). The Upper value can be set in the range of 2% to 100%. The Lower value can be set in the range of 0% to 98%. Each value can be set in 1% steps. The minimum width is 2%.

[Example]

- When Flexible Zone on CH1 is set to Upper = 20% and Lower = 0%  
The CH1 waveform is printed in the area from the bottom to 4 cm of the print area.
- When Flexible Zone on CH2 is set to Upper = 80% and Lower = 20%  
The CH2 waveform is printed in the area from 4 cm to 16 cm from the bottom of the print area.

**Graticule**• **Type**

Select the graticule type from , OFF, or .

The grid setting is linked with the DISPLAY menu > Graticule setting. However, if OFF is selected, the DISPLAY menu is set to .

• **Dark/Light**

Set the graticule Dark/Light setting to Light or Dark.

• **Width of the Vertical Graticule: Width**

Select how to set the vertical graticule width. For details on the format of the graticule lines that are printed, see page 9-10.

1div: Graticule obtained by dividing the print zone into 10 areas

10mm: mm graticule type

**Details**• **Print Interval of Scale Values: Scale**

Select the interval for the scale printed at the top and bottom edges of the print area from OFF, 200 mm, 400 mm, or 800 mm. If OFF is selected, the scale is not printed.

• **Print Interval of Channel Labels: CH Label**

Select the interval for printing waveform channel labels from OFF, 200 mm, 400 mm, or 800 mm. The channel label is printed near each waveform. If OFF is selected, the channel labels are not printed.

• **Time Print: Time**

Select the interval for printing the time from OFF, 200 mm, 400 mm, or 800 mm.

The time is printed at the top section of the print area. If OFF is selected, the times are not printed.

• **Gauge Print**

Select whether to not print (OFF), print (ON), or print in detail (Fine) on the left side of the print area. If ON is selected a gauge that equally divides the waveform display area into two is displayed. If Fine is selected, a gauge that equally divides the waveform display area into 10 is displayed. The gauge, scale values, an arrow indicating the ground position, and V/div (Value/div)\* are printed.

\* Depending on the setting, V/div (Value/div) may not be printed.

- **Annotation**

Channel information, channel messages, or measured values are printed. Use Annotation to select the print interval from OFF, 200 mm, 400 mm, and 800 mm. Use Type to select the type of annotation to be printed from CH Information, CH Message, and CH Data.

- **CH Information**

Prints settings such as V/div, filter, and module.

- **CH Message**

Prints the character string (up to 80 characters) that is assigned to each channel.

- **CH Data**

Prints the measured values at a given interval using numeric values.

The position where annotations are printed varies depending on the display (recording) format and extra area settings as follows:

- When Format is Single, Dual, Triad, or Quad, and Extra Area is ON  
The annotations are printed in the extra area. The annotations do not overlap the waveform print area.
- When Format is Single, Dual, Triad, or Quad, and Extra Area is OFF  
The annotations are printed at the bottom section of the waveform print area.
- When Format is Octal or Hexadecimal  
The annotations are printed between the divided waveform print areas (between the grids).

---

**Note**

If all of the conditions below are met, only up to 67 characters of CH Message are printed.  
Format: Single/Dual/Triad/Quad, Extra Area: OFF, Scale: Other than OFF

---

- **Comment**

A comment string of up to 20 characters can be printed at the top section of the print area. The comment setting is linked with the PRINT menu > Comment setting.

**Preview**

A preview of the print image data can be displayed in the specified output format.

**Notes on Fine Print, Zoom Print, and A4 Print**

- Fine print, zoom print, and A4 print cannot be carried out while waveform acquisition is in progress.
- Only Main waveforms are applicable for fine print and A4 print.
- If waveforms are being displayed using the history memory function, only the waveforms specified by Selected Record No. are applicable for fine print, zoom print, and A4 print.
- Fine print, zoom print, and A4 print cannot be carried out when X-Y waveforms are being displayed.
- Fine print, zoom print, and A4 print cannot be carried out on waveforms acquired using the snapshot, accumulated waveform, and dual capture functions.
- If the number of printed pages exceeds 100, fine print cannot be carried out. (The number of printed pages is determined by the Print Mag and Time Range settings.)

**Examples of Fine Print and Zoom Print**

**DL750**

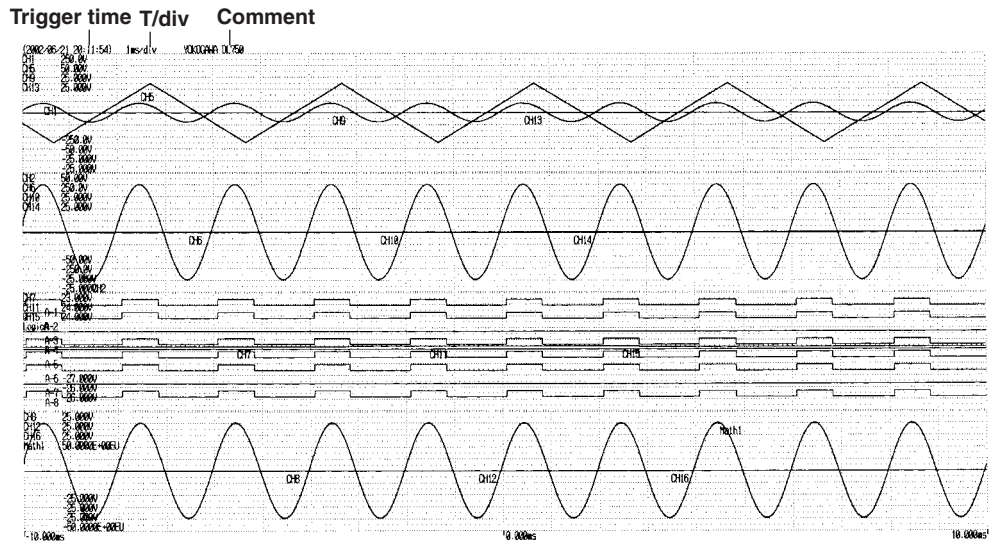

**DL750P**

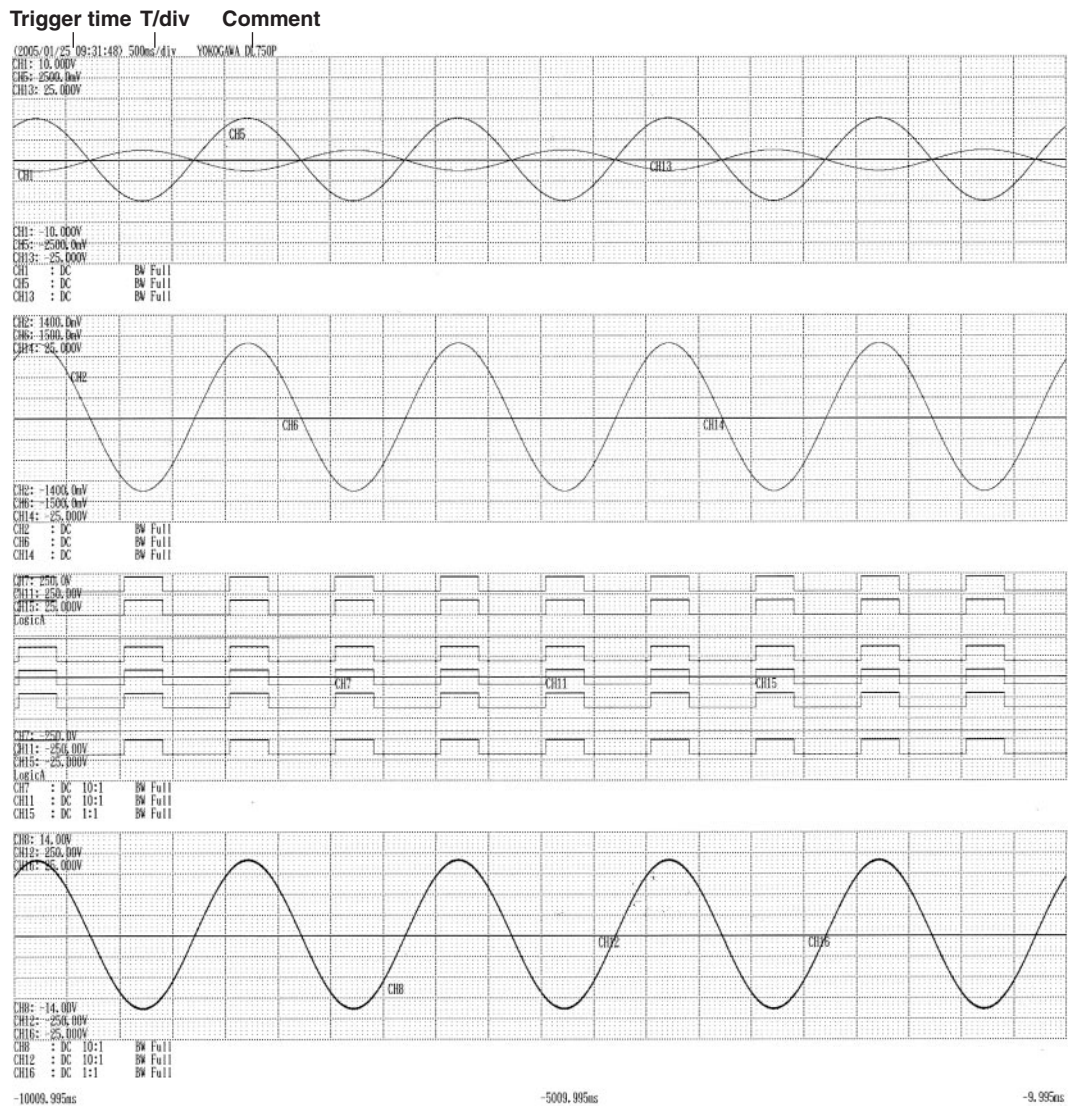



## 12.3 Printing Screen Image Data to a USB Printer

<For a description of this function, refer to page 2-62.>

### Procedure

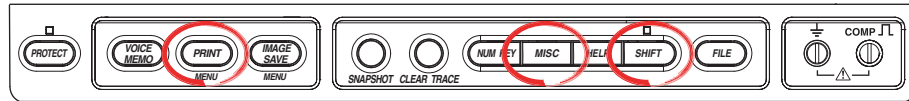

1. Connect the DL750/DL750P and a USB printer using a USB cable. For details, see the explanation in the next section.

### Selecting the Printer

2. Press **SHIFT+PRINT**.
3. Press the **Print to** soft key. The printer selection menu appears. (Net Print appears only when the Ethernet interface option is installed.)
4. Press the **USB** soft key.

### Confirming the Printer That Is Connected

5. Press the **Select** soft key. The USB Device List appears. Check the printer that is connected.

### Note

You can also check the printer that is connected from the MISC > USB > USB List soft key menu.

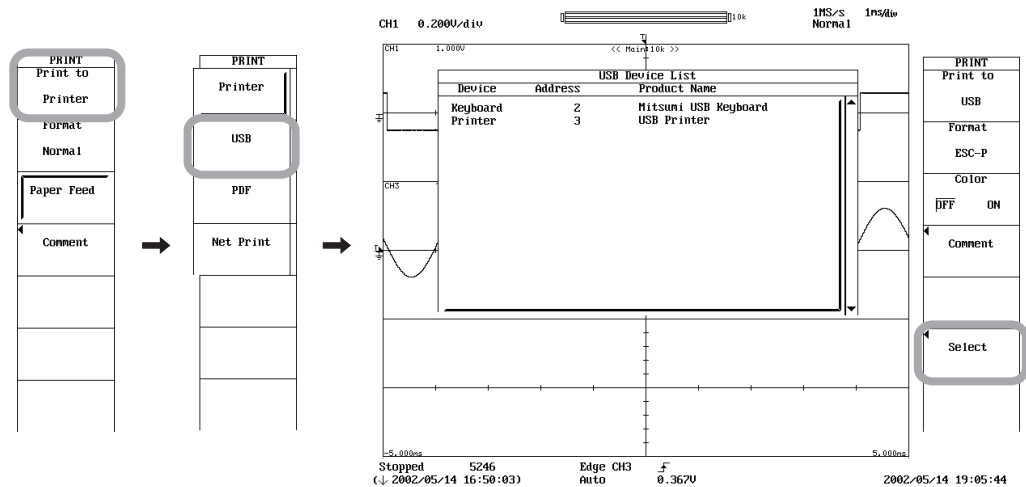

**Setting the Output Format**

6. Press the **Format** soft key. The output format selection menu appears.
7. Select the soft key corresponding to the output format from ESC-P to BJ.

**Setting the Color**

8. Press the **Color** soft key to select ON or OFF.

**Setting a Comment**

9. Press the **Comment** soft key.
10. Enter the comment string according to the procedure given in section 4.2.

**Setting the Print Resolution (When Format Is BJ)**

11. Press the **Resolution** soft key. The print resolution setup menu appears.
12. Press any of the soft keys corresponding to 180 dpi, 300 dpi, 360 dpi, and 600 dpi.

**Executing the Print Operation**

13. Press **PRINT**. The screen image data is printed on the USB printer. To abort printing, press **PRINT** while printing is in progress. While printing is in progress,  is indicated at the upper left corner of the screen.

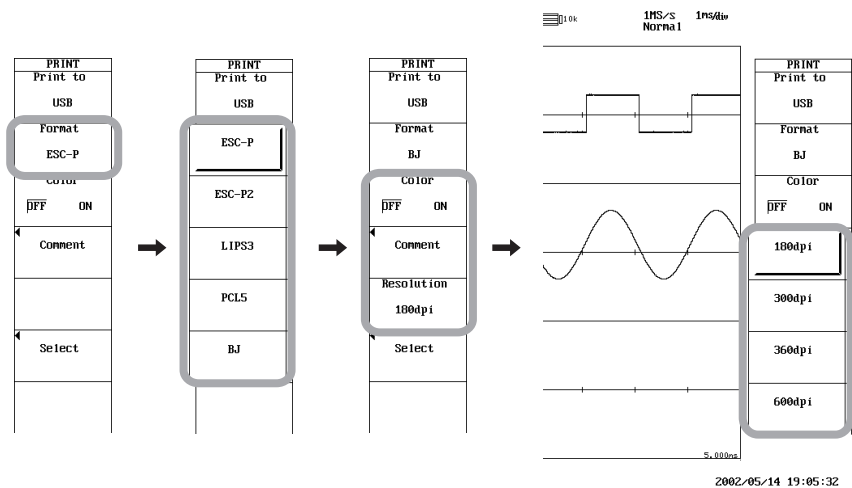

## 12.3 Printing Screen Image Data to a USB Printer

### Explanation

You can print the screen image data to a USB printer via the USB PERIPHERAL interface.

#### USB PERIPHERAL Connector

To connect a USB printer to the DL750/DL750P, connect a USB cable to the USB PERIPHERAL connector. There are two USB PERIPHERAL connectors (ports).

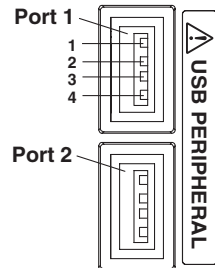

Pin No.	Signal Name
1	VBUS: +5 V
2	D-: -Data
3	D+: +Data
4	GND: Ground

#### Printers That Can Be Used

USB printers conforming to USB Printer Class Ver. 1.1 that support the following print formats can be used.

#### Note

- Connect only the printers that are allowed.
- For details on USB printers that have been tested for compatibility, contact your nearest YOKOGAWA dealer.

#### Connection Procedure

When connecting a USB printer, directly connect the keyboard to the DL750/DL750P using a USB cable as shown below. You can connect the USB cable regardless of the power ON/OFF state of the DL750/DL750P (supports hot-plug). Connect the type A connector of the USB cable to the DL750/DL750P; connect the type B connector to the printer. When the power switch is ON, the printer is detected and enabled approximately 6 s after it is connected.



#### Note

- Connect the printer directly without going through a hub.
- Do not connect USB devices other than USB keyboard, USB mouse, USB printer, and USB storage device that can be used to the USB PERIPHERAL connector.
- Do not connect multiple printers to the USB PERIPHERAL connector.
- Never turn OFF the printer or remove the USB cable while the printer is printing.
- Do not connect or disconnect the USB cable after the power is turned ON until key operation is ready (approximately 20 to 30 s).

**Output Format**

You can select the output format that is sent to the USB printer from the following six types.

- ESC-P
- ESC-P2
- LIPS3
- PCL5
- BJ (can be used on models that support the BJC-35V native commands)
- ESC-PR\* (Applies to Firmware Version 6.21 or Later)
  - \* This is an output format for Seiko-Epson printers. If you choose this format you must select either Normal (for 4 x 6 printers) or Small (for Letter size printers).

**Output Resolution When Printing Using the BJ Format**

When printing the screen image data to a USB BJ printer, select the output resolution from 180 dpi, 300 dpi, 360 dpi, and 600 dpi.

**Comment**

A comment string of up to 0 characters can be printed at the bottom right section. The comment setting is linked with the PRINT menu > Comment setting.

**Color**

Select from the following:

- ON: Print the data using colors similar to the screen. (No background color and grid printed in black)
- OFF: Prints the image using the same colors as the image printed using the built-in printer.

**Notes When Printing on the USB Printer**

- Images may not print properly on some printers. Use USB printers that have been tested for compatibility. For details on USB printers that have been tested for compatibility, contact your nearest YOKOGAWA dealer.
- You can also print to a USB printer that is connected to your PC. Save the screen image data to a floppy disk, a Zip disk, or a PC card according to the procedure given in section 13.11, "Saving Screen Image Data." Then, load the data on the PC and print it.
- Connect only the printers that are allowed.

**Note**

The DL750/DL750P does not detect "out of paper" and printer errors on the USB printer. If an error occurs, press PRINT again to stop the printing.

# 12.4 Printing the Screen Image Data on a Network Printer

<For a description of this function, refer to page 2-62.>

## Procedure

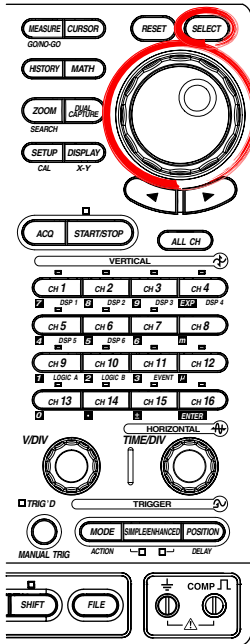
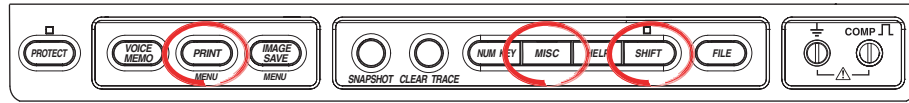

### Configuring the Network

1. Configure the TCP/IP and network printer according to the procedures given in section 16.2, "Configuring the TCP/IP" and section 16.4, "Configuring the Network Printer."

### Selecting the Printer

2. Press **SHIFT+PRINT**.
3. Press the **Print to** soft key. The printer selection menu appears. (Net Print appears only when the Ethernet interface option is installed.)
4. Press the **Net Print** soft key.

### Selecting the Output Format

5. Press the **Format** soft key.
6. Select the soft key corresponding to the output format from ESC-P to PostScript.

### Setting the Color (When Format Is ESC-P, ESC-P2, PCL5, or BJ)

7. Press the **Color** soft key to select ON or OFF.

### Setting a Comment

8. Press the **Comment** soft key.
9. Enter the comment according to the procedure given in section 4.2.

### Setting the Print Resolution (When Format Is BJ)

10. Press the **Resolution** soft key. The print resolution setup menu appears.
11. Press any of the soft keys corresponding to 180 dpi, 300 dpi, 360 dpi, and 600 dpi.

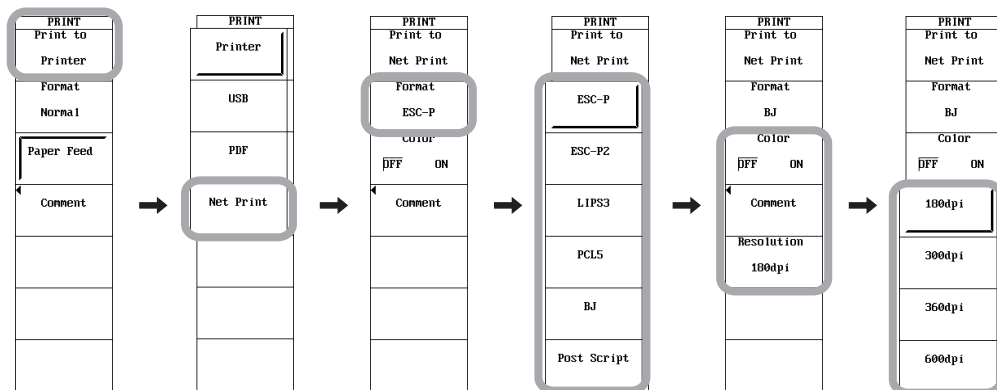

### Executing the Print Operation

12. Press **PRINT**. The screen image data is printed on the network printer. To abort printing, press **PRINT** while printing is in progress. While printing is in progress,  is indicated at the upper left corner of the screen.

### Explanation

Like the built-in printer, you can print the screen image data on a network printer<sup>1</sup> via the Ethernet network.

1. Printing is possible on a printer or printer server supporting the TCP/IP protocol.

### Selecting the Output Format

The following six printer formats are supported.

- ESC-P
- ESC-P2
- LIPS3
- PCL5
- BJ
- PostScript

### Output Resolution When Printing Using the BJ Format

When printing the screen image data to a BJ printer, select the output resolution from 180 dpi, 300 dpi, 360 dpi, and 600 dpi.

### Comment

A comment string of up to 20 characters can be printed at the bottom right section. The comment setting is linked with the PRINT menu > Comment setting.

### Color

Select from the following:

- ON: Print the data using colors similar to the screen. (No background color and grid printed in black)
- OFF: Prints the image using the same colors as the image printed using the built-in printer.

### Note

---

Printing is possible on printers that support the TCP/IP protocol.

---

## 13.1 Floppy Disks/Zip Disks/PC Cards

Three types of built-in storage are available: floppy disk drive, Zip disk drive (DL750 only), and PC card drive (one type is selected at the time of purchase).

### Floppy Disks That Can Be Used

The following types of 3.5" floppy disks can be used. You can format the disk on the DL750/DL750P.

- **2HD**  
Formatted to 1.44 MB using MS-DOS.
- **2DD**  
Formatted to 720 KB using MS-DOS.

### Inserting the Floppy Disk into the Floppy Disk Drive

With the label facing toward you, insert the disk from the side with the shutter. Insert the disk until the eject button pops out.

### Removing the Disk from the Floppy Disk Drive

Check that the access indicator is turned OFF and press the eject button.

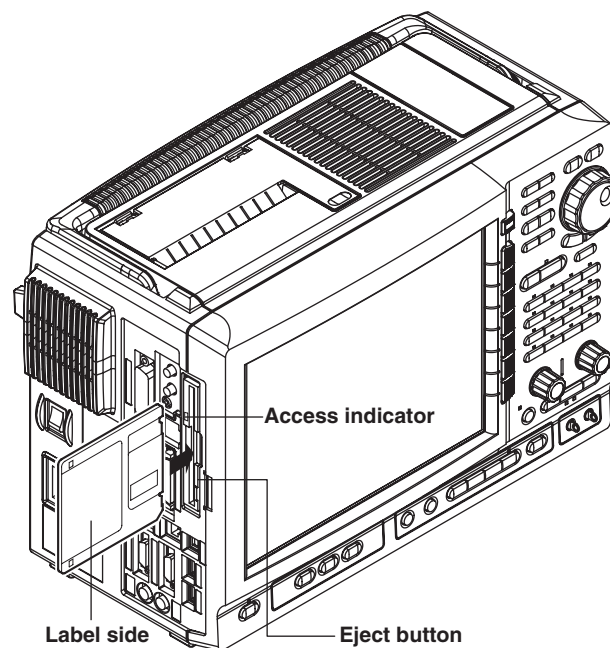

### **CAUTION**

Removing the floppy disk while the access indicator is blinking can damage the magnetic head of the floppy disk drive or destroy the data on the floppy disk.

### **General Handling Precautions of Floppy Disks**

The DL750/DL750P cannot read floppy disks with bad sectors. Repair the sectors using a PC before using those disks in the DL750/DL750P.

For the general handling precautions of the floppy disk, read the instruction manual that came with the floppy disk.

## Zip Disks

### Zip Disks That Can Be Used

The following types can be used. You can format the disk on the DL750.

Size: 100 MB or 250 MB

Format: FDISK 1 partition (hard disk format)

### Inserting the Zip Disk into the Zip Drive

With the label facing toward you, insert the disk from the side with the shutter.

### Removing the Zip Disk from the Zip Drive

With the DL750 turned ON, check that the access indicator is OFF and press the eject button.

If you need to use the Zip disk again, wait at least three seconds after removing it before reinserting it into the drive.

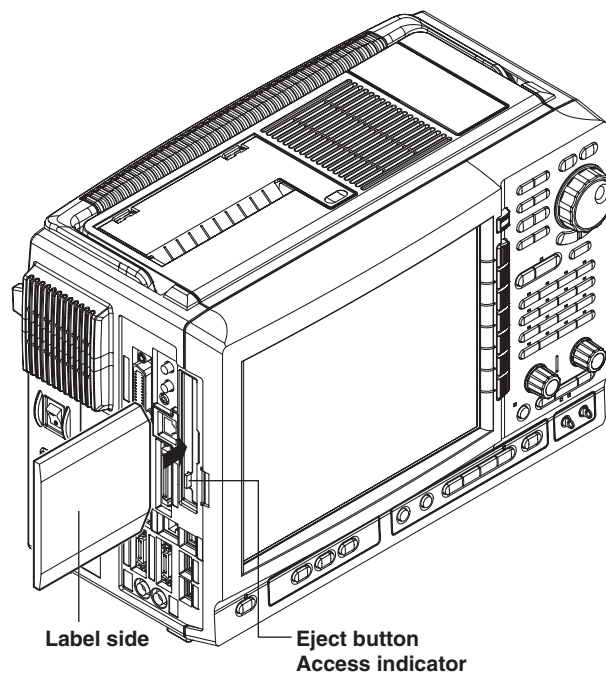



**Procedure When the Zip Disk Cannot Be Ejected**

If the Zip disk cannot be removed by performing the steps above, carry out the following steps to remove it.

Insert a pin of approx. 1 mm in diameter into the eject button hole and press slowly. This will cause the Zip disk to be ejected.

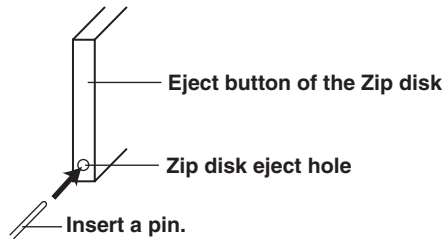
**CAUTION**

- Removing the Zip disk while the access indicator is ON may destroy the data on the Zip disk.
- Do not use the Zip drive if the DL750 is installed using the stand. (For the installation position, see section 3.2.)
- When turning ON/OFF the DL750, have the Zip disk removed from the drive.
- Do not insert the Zip disk into the drive, or remove the Zip disk from the drive while the DL750 is starting up after turning ON the power (see section 3.4, "Power Up Operation"). Doing so can damage the disk.
- The access indicator illuminates immediately after the Zip disk is inserted. Do not operate the DL750 while the access indicator is illuminated. Such act can lead to erroneous operation.

**General Handling Precautions of Zip Disks**

For the general handling precautions of the Zip disk, read the instruction manual that came with the Zip drive.

### PC Cards

#### PC Cards That Can Be Used

The DL750/DL750P supports flash ATA cards (PC card TYPE II) and compact flash (using the PC card TYPE II adapter). In addition, some of the Flash ATA HDD cards can be used.

For details, contact your nearest YOKOGAWA dealer.

#### **Note**

---

To use the PC card on the PC, use a PC that supports the PC card. Depending on the PC that you are using, the PC cards indicated above may not operate properly. Check it beforehand.

---

#### Inserting the PC Card

With the label side of the PC card facing toward you, insert the PC card into the drive. The PC card drive is located on the left side panel of the DL750/DL750P.

#### Ejecting the PC Card

Check that the PC card is not being accessed, and press the PC card ejection button to the right of the drive.

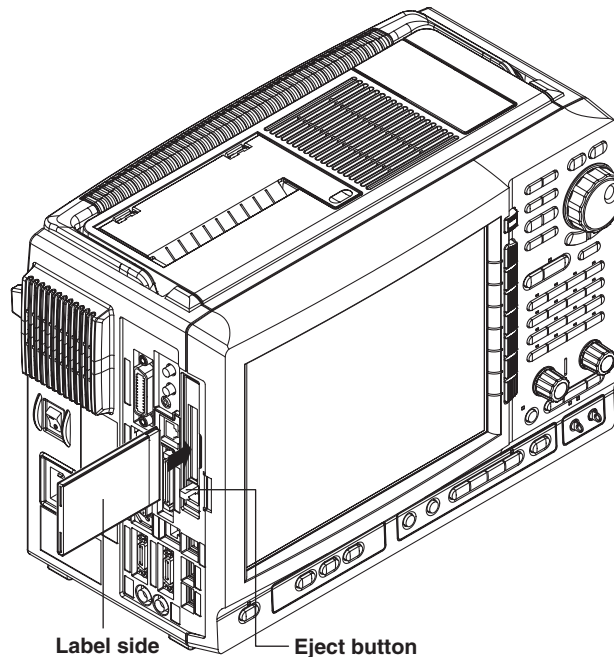

---

### **CAUTION**

- The DL750/DL750P may malfunction if the PC card is frequently inserted and ejected (inserted and ejected within a 1-s time period).
  - Removing the PC card while it is being accessed may destroy the data on the PC card.
-

**General Handling Precautions of PC Cards**

For the general handling precautions of the PC card, read the instruction manual that came with the PC card.

## 13.2 Internal Hard Disk (Optional)



### CAUTION

- When using the DL750/DL750P in a vibrating environment, turn OFF the motor rotation of the internal hard disk.
- Do not place more than 512 files in the root directory of the internal hard disk. If the number of files exceeds 512, all file access operations slows down. In addition, the operation of realtime recording cannot be guaranteed.
- If an external SCSI device is connected, do not change the HDD Motor setting.

### Procedure



1. Press **MISC**.
2. Press the **Next 1/2** soft key.
3. Press the **Others** soft key.
4. Press the **HDD Motor** soft key to select ON or OFF.

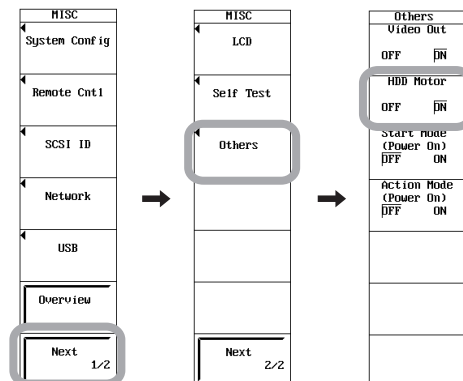

### Explanation

You can turn ON/OFF the motor rotation of the internal hard disk on the DL750/DL750P. If you turn OFF the internal hard disk motor, the internal hard disk cannot be accessed. To save various data to the internal hard disk, turn the HDD Motor ON. Turning OFF the HDD Motor protects the internal hard disk from vibrations.

### Note

Even if the motor rotation is turned OFF, the motor rotation is turned ON for approximately 1 minute after the power is turned ON.

## 13.3 Connecting a USB Storage Device (MO Disk Drive, Hard Disk, or Flash Memory) to the USB PERIPHERAL Interface

### Model That Can Connect a USB Storage Device

- DL750: Check the overview screen by choosing MISC > Overview. If USB Storage: Yes and Soft Version: 6.02 (or later) are displayed, a USB storage device can be connected.
- DL750P: All DL750Ps can connect to a USB storage device.

### USB PERIPHERAL Interface Specifications

Item	Specifications
Connector type	USB type A connector (receptacle)
Electrical and mechanical specifications	Conforms to USB Rev.1.1
Data rate	12 Mbps maximum
Power Supply	5 V, 500 mA* (per port)
Number of ports	2

\* Devices whose maximum current consumption exceeds 100 mA cannot be connected simultaneously to the two ports.

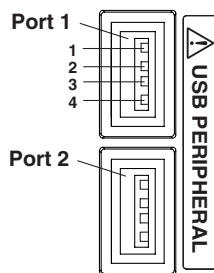

Pin No.	Signal Name
1	VBUS: +5 V
2	D-: -Data
3	D+: +Data
4	GND: Ground

### Connecting the USB Storage Device

When connecting a USB storage device, directly connect the printer to the DL750/DL750P using a USB cable as shown below. You can connect the USB cable regardless of whether the power switch on the DL750/DL750P is ON or OFF (supports hot-plugging). When the power switch is ON, the USB storage device is detected and enabled approximately six seconds after it is connected.

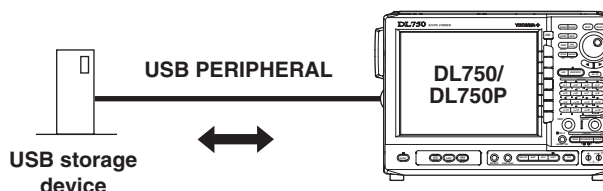

### 13.3 Connecting a USB Storage Device (MO Disk Drive, Hard Disk, or Flash Memory) to the USB PERIPHERAL Interface

---

#### **Compatible USB Storage Devices**

The DL750/DL750P can use HD drives, MO drives, and flash memories that support USB (USB Mass Storage Class).

#### **Note**

- Do not connect USB devices other than a USB keyboard, USB mouse, USB printer, or USB storage device to the USB PERIPHERAL connector.
  - The DL750/DL750P has two USB PERIPHERAL ports. However, USB devices whose maximum consumption current exceeds 100 mA cannot be connected simultaneously to the two ports.
- 

---

#### **CAUTION**

- Do not remove the USB storage device or turn OFF the power when the USB storage device is being accessed. If you do, the data on the USB storage device may be destroyed.
  - An access icon is displayed at the upper left corner of the screen while the USB storage device is being accessed.
- 

#### **General Handling Precautions of USB Storage Devices**

For the general handling precautions of the USB storage device, read the instruction manual that came with the device.

# 13.4 Connecting a SCSI Device

## SCSI Specifications

Item	Specifications
Interface standard	SCSI (Small Computer System Interface), ANSI X3.131-1986
Connector type	Half pitch 50 pins (pin type)
Connector pin assignment	Unbalanced (single-ended), see table below.

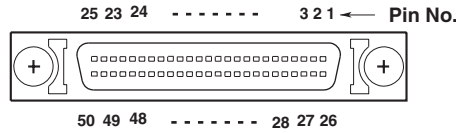

Pin No.	Signal Name	Pin No.	Signal Name
1 to 12	GND	38	TERMPWR
13	NC	39, 40	GND
14 to 25	GND	41	-ATN
26	-DB0	42	GND
27	-DB1	43	-BSY
28	-DB2	44	-ACK
29	-DB3	45	-RST
30	-DB4	46	-MSG
31	-DB5	47	-SEL
32	-DB6	48	-C/D
33	-DB7	49	-REQ
34	-DBP	50	-I/O
35 to 37	GND		

### Items Necessary for Connection

#### Cable

Use a commercially sold cable that is 3 m or less in length that has a characteristic impedance between 90 and 132 Ω.

### Connection Procedure

1. Connect the SCSI cable to the SCSI connector on the left side panel of the DL750/DL750P.
2. Turn ON the SCSI device and the DL750/DL750P (in that order).  
To format the disk, follow the procedure described in the section 13.5, "Formatting the Storage Medium."

### Connectable SCSI Devices

SCSI devices that can be connected to the DL750/DL750P are MO disk drives and Zip drives.

For details on which devices can be connected, contact your nearest YOKOGAWA dealer.

For general handling precautions for the connected SCSI device, see the instruction manual that is provided with the device.

#### Note

- If the external SCSI device that is connected cannot be detected on the DL750/DL750P, execute the initialization of the SCSI ID using SCSI ID > Initialize SCSI on the MISC menu.
- The DL750/DL750P has a built-in SCSI terminator. When using multiple SCSI devices, connect the DL750/DL750P to the end of the chain. The terminator is always ON when the power is ON.
- Do not connect an external SCSI device with the same ID as that specified using SCSI ID > Internal ID on the MISC menu.

# 13.5 Formatting the Storage Medium



## CAUTION

- Never remove the storage medium (disk) or turn OFF the power while the access indicator or the floppy disk, Zip disk, or hard disk icon is blinking. Such acts can damage the storage medium or destroy the data on the medium.
- If the DL750/DL750P cannot recognize a formatted medium, format the disk again on the DL750/DL750P. Note that all the data on the disk are cleared when the disk is formatted. Make sure to back up important data beforehand.

### Procedure

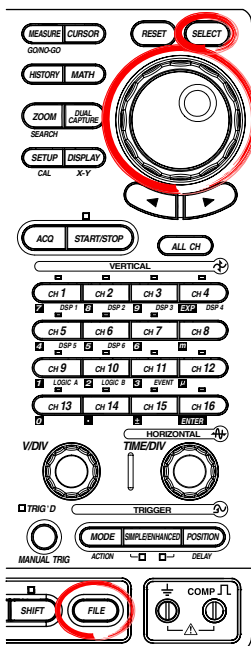

1. Press **FILE**.
2. Press the **Utility** soft key. The Utility setup menu and the File List window appear.

### Selecting the Storage Medium to Be Formatted

3. Press the **Function** soft key. The file function selection menu is displayed.
4. Press the **Format** soft key. A media list is displayed in the File List window. (Net Drive cannot be formatted.)

5. Turn the  **jog shuttle** to select the storage medium to be formatted.  
If no external SCSI devices (option) or USB storage devices are detected, the internal hard disk option is not installed, and only the floppy disk, Zip disk, or PC card is inserted in the drive, only [FD], [Zip], or [PC card] is displayed.

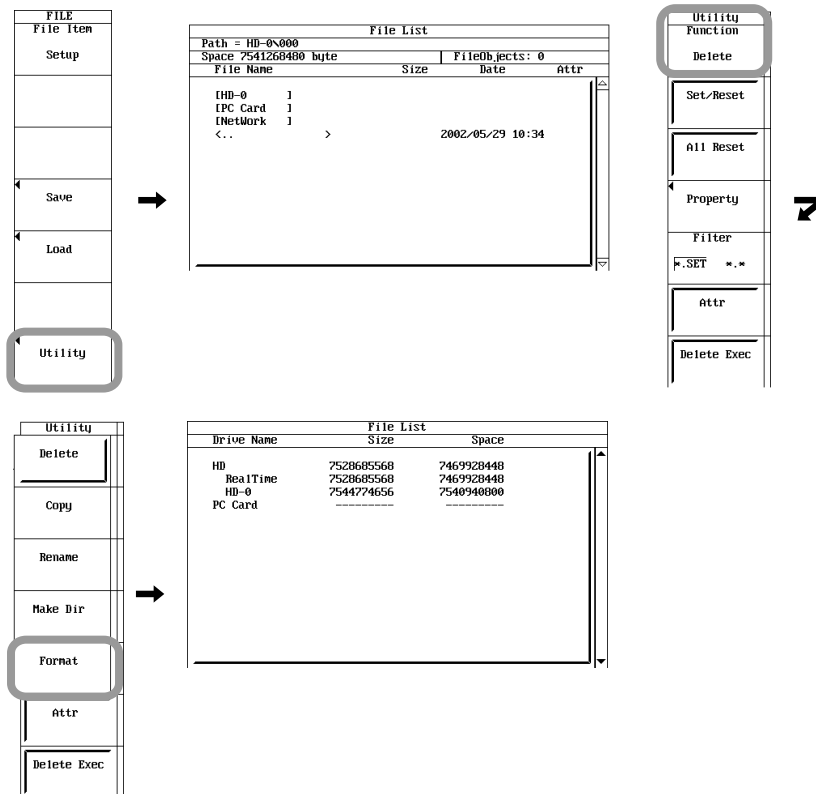



**Selecting the FD Format**

6. Press the **Format** soft key. The format selection menu appears.
7. Turn the **jog shuttle** to select 2DD 720K or 2HD 1.44M. Proceed to step 9.

**Selecting the Zip Disk, PC Card, or USB Storage Device Format**

6. Press the **Format** soft key. The format selection menu appears. No setting is necessary in formatting the Zip disk, PC card, or USB storage device. Proceed to step 11.

**Selecting the Number of Partitions of the PC Card**

6. Press the **Format** soft key. The format selection menu appears. Proceed to step 9.

**Selecting the Number of Partitions of the SCSI Device**

6. Press the **Format** soft key. The format selection menu appears.
7. Press the **Partition** soft key.
8. Turn the **jog shuttle** to set the number of partitions. Proceed to step 9.

**Note**

The number of partitions is 1 for removable disks (such as SCSI and Zip disks).

**Selecting the Number of Partitions of the Internal Hard Disk (Optional)**

• **Selecting the Number of Partitions**

6. Press the **Format** soft key. The format selection menu appears.
7. Press the **Partition** soft key.
8. Turn the **jog shuttle** to set the number of partitions to 2 or 3.

• **Setting the Realtime Recording Area**

9. Press the **RealTime Recording Area** soft key.
10. Turn the **jog shuttle** to set the realtime recording area in the range of 30 to 70% of the entire capacity of the internal hard disk. Proceed to step 11.

**Note**

Do not place files other than those created by realtime recording in the Real Time area of the internal hard disk. Otherwise, the realtime recording may not operate properly.

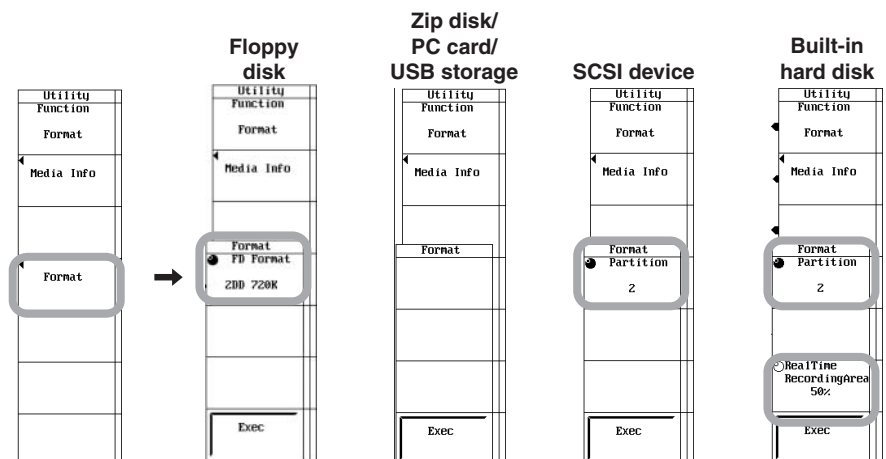







## 13.5 Formatting the Storage Medium

### Executing/Aborting the Format Operation

9. Press the **Exec** soft key. An Alert dialog box appears.
10. Turn the **jog shuttle** to select OK or cancel.
11. Select OK and press **SELECT** to execute the format operation.

Select Cancel and press **SELECT** to cancel the format operation.

While the medium is being formatted, an icon corresponding the medium (  FD,  Zip disk,  PC card,  external SCSI device,  internal HD, or  USB storage device) being formatted is displayed at the upper left corner of the screen.

Select Cancel and press **SELECT** to cancel the format operation.

### Viewing the Media Information

Select the storage medium according to steps 1 to 5.

Press the **Media Info** soft key. The information about the storage medium that was selected in step 5 is displayed.

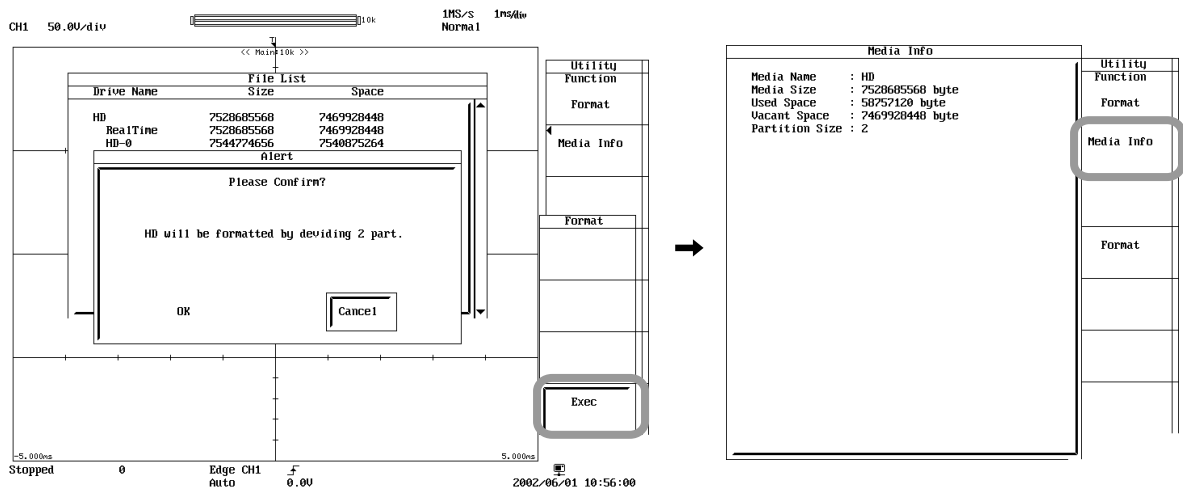

## Explanation

### Formatting a Floppy Disk

When using a new floppy disk, you must format it. Select the format that is appropriate for the floppy disk that you are using from below.

- **2DD 720K**  
Formats a 2DD floppy disk to 720 KB/9 sectors.
- **2HD 1.44M**  
Formats a 2HD floppy disk to 1.44 MB/18 sectors.

### Formatting a Zip Disk, PC Card, or USB Storage Device

When using a new Zip disk, you need to format it.

The format for 250 MB and 100 MB disks is as follows:

FDISK 1 partition

Flash ATA cards are formatted to IBM-compatible format.

2GB or more: FAT32

Less than 2GB: FAT16

### Formatting an External SCSI Device

The formats of the disk that are connected via the SCSI (option) are as follows:

- **MO**  
Semi-IBM format. Handled as a removable disk.
- **Zip**  
FDISK 1 partition. Handled as a fixed disk.

### Formatting the Internal Hard Disk (Optional)

- **Selecting the Number of Partitions**  
You can set the number of partitions to 2 or 3.
- **Setting the Realtime Recording Area**  
You can set the realtime recording area to 30%, 40%, 50%, 60%, or 70% of the entire capacity of the internal hard disk. The default value is 50%.

### Selecting the Number of Partitions

You can set partitions on the internal hard disk (optional) and some of the external SCSI devices. However, partitions cannot be specified on removable disks. You can select the number of partitions from 1 to 3 (2 or 3 on the internal hard disk).

## 13.5 Formatting the Storage Medium

---

### **Media Info**

Lists the information about the selected medium. The following information is displayed.

- Media Name: Name of the medium.
- Media Size: Total size.
- Used Space: Size of the used area.
- Vacant Space: Size of the free area.
- Partition Size: Number of partitions.

### **Note**

---

- If you format a medium that has data stored on it, all the data are cleared when the medium is formatted.
  - It takes approximately a minute and a half to format a floppy disk.
  - It takes approximately 10 s to format a 250-MB Zip disk.
  - It takes a few seconds to format a PC card.
  - It takes approximately 30 s to 1 minute to format the internal hard disk (optional).
  - You cannot format a floppy disk if the write-protect is ON.
  - Do not format a disk while the DL750/DL750P and a PC is connected via a SCSI cable.
  - Floppy disks that are formatted to formats other than those listed in this section cannot be used.
  - If an error message is displayed after the format operation, the target medium may be damaged.
  - You can use floppy disks that are formatted using MS-DOS on a PC.
  - This function cannot be used when using the FTP server function, the FTP client function, network printer function or the Web server function.
-

# 13.6 Changing the SCSI ID Number

## Procedure

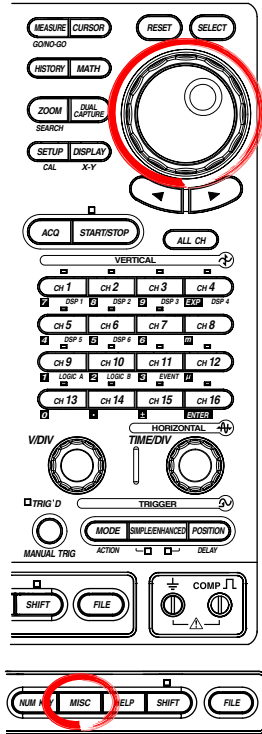

1. Press **MISC**.
2. Press the **SCSI ID** soft key. The SCSI ID number setup menu appears.

### Changing the ID Number of the DL750/DL750P

3. Press the **Own ID** soft key.
4. Turn the **jog shuttle** to select a value in the range of 0 to 7.

### Changing the ID Number of the Internal Hard Disk

5. Press the **Internal ID** soft key.
6. Turn the **jog shuttle** to select a value in the range of 0 to 7.

### Executing the ID Number Change

7. Press the **Initialize SCSI** soft key. The SCSI ID is changed to the selected ID number.

The SCSI icon () at the upper left corner of the screen blinks while the change is in progress. When the change is complete, the icon disappears.

### Note

- If you do not execute Initialize SCSI after changing Own ID or Internal ID, the new ID is not activated until the DL750/DL750P is powered up the next time.
- To save the data after executing Initialize SCSI, select the destination medium and directory.

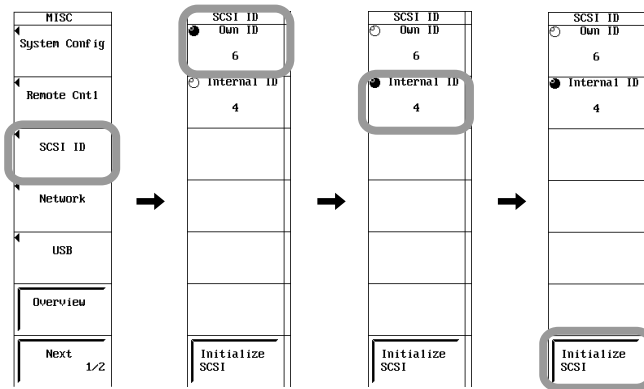

### ***Explanation***

The SCSI ID number is used to distinguish between the various devices connected to the SCSI chain. Make sure not to use duplicate ID numbers on any of the connected devices.

#### **Selectable Range of Own ID Number**

Own ID (the ID number of the DL750/DL750P) can be set in the range of 0 to 7. The default value is 6.

#### **Selectable Range of Internal ID Number**

Internal ID (ID number of the internal hard disk (optional) can be set in the range of 0 to 7. The default value is 4.

#### **Notes When Setting the ID Number**

- If you change the ID number, make sure to press the Initialize SCSI soft key.
- Do not set the same SCSI ID number for the external SCSI device and the internal hard disk of the DL750/DL750P.
- The SCSI ID numbers of external SCSI devices are automatically detected when the DL750/DL750P is turned ON.
- If you change the ID number of the external SCSI device, make sure to execute Initialize SCSI to detect the new SCSI ID.
- SCSI ID (Own) and SCSI ID (Internal) cannot be set to the same value.

# 13.7 Saving/Loading the Waveform Data

<For a description of this function, refer to page 2-64.>



## CAUTION

Never remove the storage medium (disk) or turn OFF the power while the access indicator or the floppy disk, Zip disk, or internal hard disk (optional) icon is blinking. Such acts can damage the storage medium or destroy the data on the medium.

### Procedure

#### Saving the Waveform Data

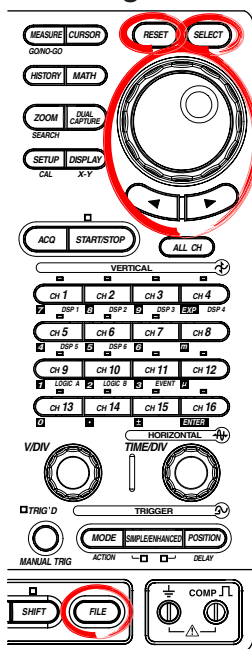

1. Press **FILE**.
2. Press the **File Item** soft key. The File Item setup menu appears.
3. Press the **Waveform** soft key.

#### Selecting the Data Type

4. Press the **Data Type** soft key. The data type selection menu appears.
5. Press the **Binary**, **ASCII**, or **Float** soft key to select the data type.

#### Note

- Binary files can be saved and loaded. ASCII and Float files can only be saved.
- Select Real Time when loading or converting the waveform that has been realtime recorded. For details, see section 13.14.
- The data type is synchronized to the data type that is selected when Save to File is selected for the action-on-trigger, action on log end (see section 6.18), or GO/NO-GO determination (see sections 11.8 and 11.9) action.

#### Selecting the Waveform to Be Saved

6. Press the **Save** soft key. The save setup menu appears.
7. Press the **Trace** soft key. The waveform selection menu appears.
8. Press the soft key corresponding to the desired channel to select the waveform.

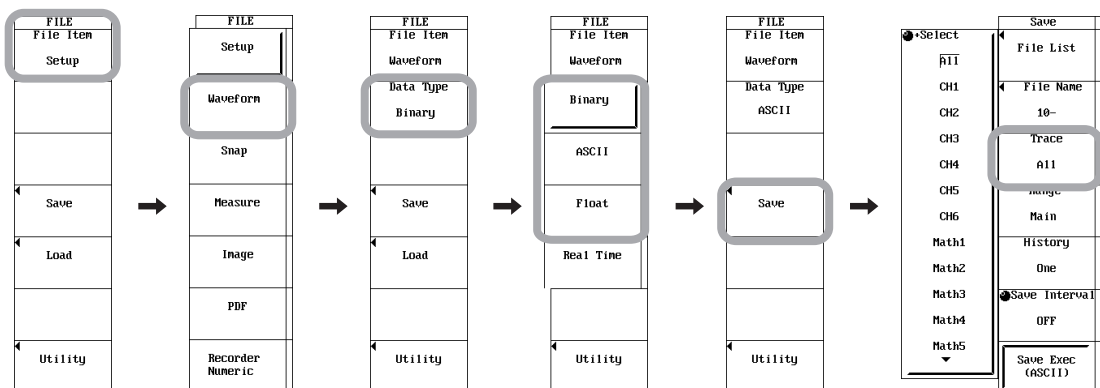

## 13.7 Saving/Loading the Waveform Data

### Selecting the Range of Waveform to Be Saved

9. Press the **Range** soft key. A menu for selecting the range of waveform to be saved appears.
10. Press the **Main**, **Z1**, or **Z2** soft key to select the waveform save range.
11. Press the **History** soft key to save all the data in the history memory (**All**), save only the selected waveform (**One**), or save the average data in the history memory (**Ave**).

If you select **All** after performing a search on the history memory data, only the searched waveforms are saved.

### Compressing the Data and Saving/Decimating the Data and Saving

- **Decimating the Data and Saving (When Data Type Is Set to ASCII)**

12. Press the **Save Interval** soft key.  
Turn the **jog shuttle** to set the save interval from OFF, Per5 to Per5000.

- **Compressing the Data and Saving (When Data Type Is Set to Binary)**

12. Press the **P-P Comp** soft key to select ON (compress and save) or OFF (do not compress and save).

If P-P Comp is turned ON when saving waveform data, only the maximum and minimum values of the multiple data points existing at the same time position are saved. Consequently, the file size is reduced.

### Note

If P-P Comp is set to ON, you cannot set the save range using Range.

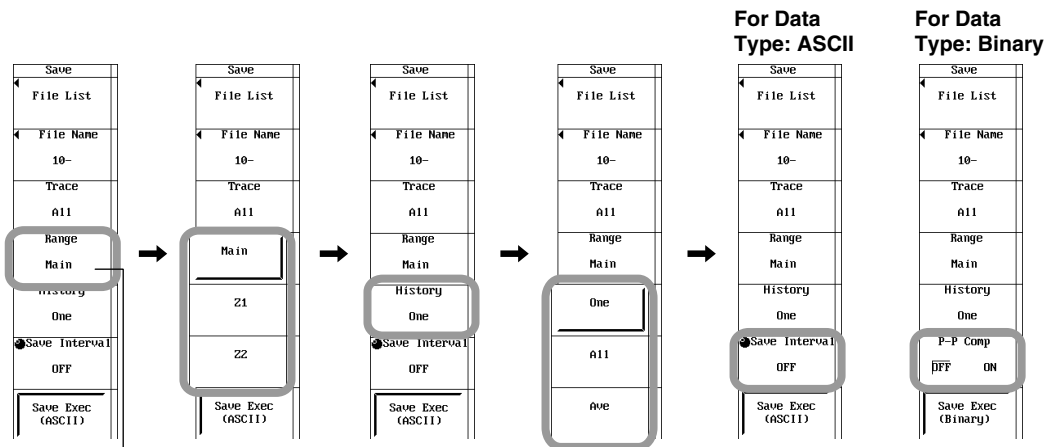



**Selecting Save Destination Medium**

13. Press the **File List** soft key. The File List window appears.
14. Turn the **jog shuttle** to select the save destination medium (indicated by brackets).
15. Press **SELECT** to confirm the storage medium.

**Selecting the Destination Directory**

(Perform this operation when directories are present on the medium.)

16. Turn the **jog shuttle** to select the save destination directory (indicated by < >).
17. Press **SELECT** to confirm the directory. The selected medium/directory is displayed in "Path=....." located above and to the left of the File List window. Select <..> to move to the parent directory.

**Note**

If History is set to All, MATH channels are not saved. If you wish to save the data of MATH channels, set History to One.

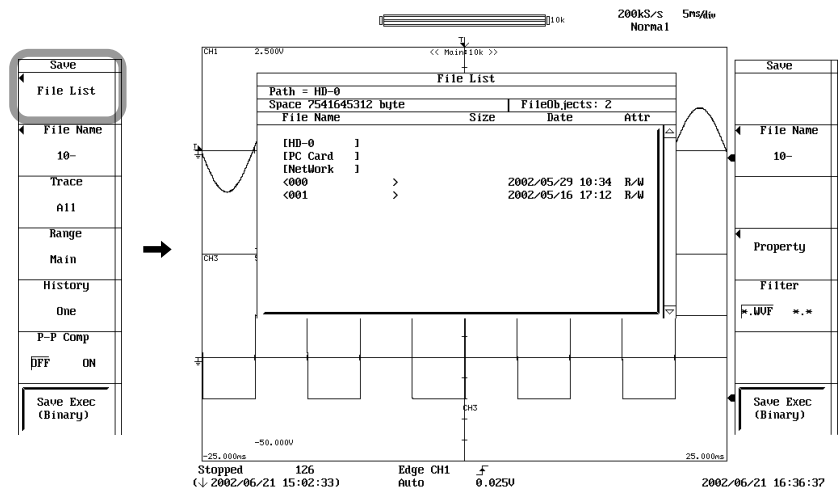







## 13.7 Saving/Loading the Waveform Data

### Setting the File Name and Comment

18. Press the **File Name** soft key. The file name setup menu appears.
19. Turn the **jog shuttle** to select Auto Naming.
20. Press **SELECT** to select OFF, Numbering, or Date.
21. Turn the **jog shuttle** to select File Name.
22. Enter the file name using up to 16 characters according to the procedure given in section 4.2.
23. Turn the **jog shuttle** to select Comment.
24. Enter the comment using up to 160 characters according to the procedure given in section 4.2.

### Executing the Save Operation

25. Press the **Save Exec** soft key. The data is saved to the directory indicated by Path=..... At the same time, the **Save Exec** soft key changes to an **Abort** soft key.  
While the data is being saved, an icon corresponding the save destination medium (  FD,  Zip disk,  PC card,  external SCSI device,  internal HD, or  USB storage device) is displayed at the upper left corner of the screen.

### Note

The voice memo function (section 7.9) can be used to record voice memos while waveforms are being acquired (when in roll mode display). The voice memo is saved along with the waveform data. Voice memo can be attached only to waveform data in binary format (.wvf extension) and realtime recorded waveform data (.wdf extension). In addition, the voice memo is saved only when History: One is selected in step 11 of page 13-18.

### Aborting the Save Operation

26. Press the **Abort** soft key. The save operation is aborted. At the same time, the **Abort** soft key changes to a **Save Exec** soft key.

### Specifying the File to Be Displayed on the File List Window

27. On the screen showing the File List window, press the **Filter** soft key to select \*.extension or \*.\*.
28. Turn the **jog shuttle** to select the files in the File List window.

### Displaying Properties

29. Press the **Property** soft key. Information about the selected file is displayed.

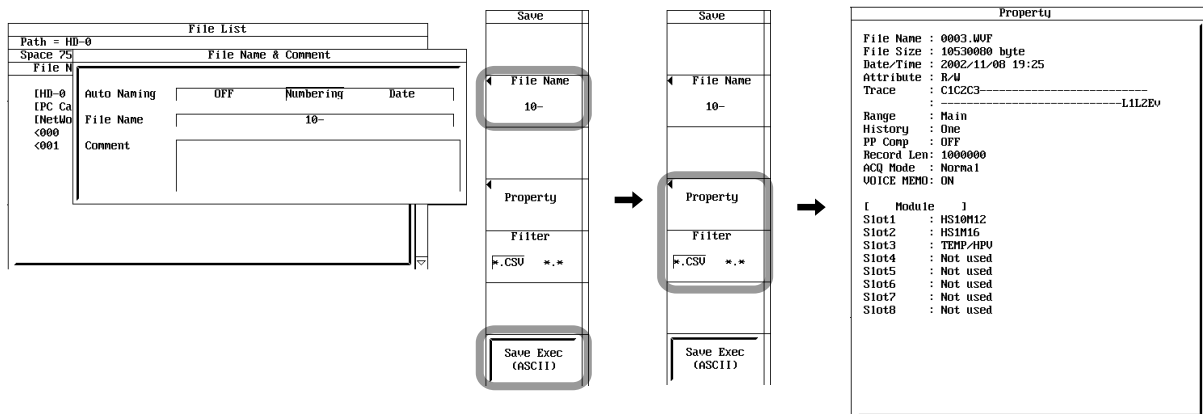

### Loading the Waveform Data

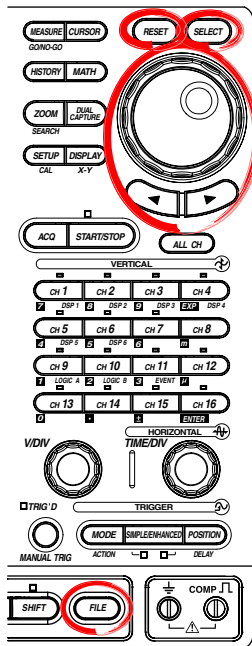

1. Press **FILE**.
2. Press the **File Item** soft key. The File Item setup menu appears.
3. Press the **Waveform** soft key.

#### Selecting the Data Type

4. Press the **Data Type** soft key. The data type selection menu appears.
5. Press the **Binary** soft key.

#### Selecting the Load Source Medium/Directory

6. Press the **Load** soft key. The load setup menu and File List window appear.
7. Select the load source directory according to steps 13 to 18 in “Saving the Waveform Data.”

#### Selecting the File to Be Loaded

8. Turn the **jog shuttle** to select the file.

#### Executing the Load Operation

9. Press the **Load Exec** soft key. A dialog box appears showing the module information of the selected waveform data and the current module information of the DL750/DL750P.
10. Press the **Load Exec** soft key again. The selected file is read from the directory indicated in Path=..... At the same time, the **Load Exec** soft key changes to an **Abort** soft key.

#### Note

- Waveform data on modules whose information differs from the current module information of the DL750/DL750P cannot be loaded.
- Waveform data that has voice memo recorded (waveform data in binary format (.wvf extension) and realtime recorded waveform data (.wdf extension)) can also be loaded. For details on the voice memo function, see section 7.9.

#### Aborting the Load Operation

11. Press the **Abort** soft key. The load operation is aborted. At the same time, the **Abort** soft key changes to a **Load Exec** soft key.

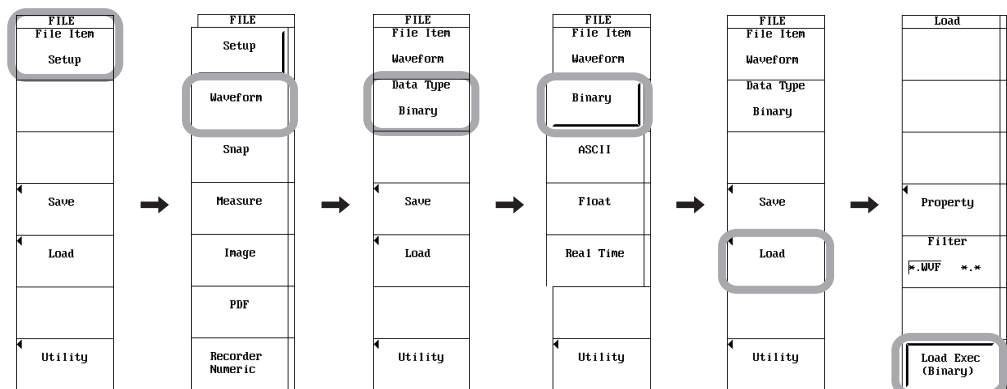

#### Specifying the Files to Be Displayed in the File List Window and Displaying Properties

12. Carry out steps 27 to 29 in “Saving the Waveform Data.”

#### Note

When a file saved by specifying Z1 (or Z2) is loaded, the data of the record length of Z1 (or Z2) is displayed right justified.

### **Explanation**

#### **Selecting the Data Type**

- **Binary**

- The sampled data in the acquisition memory is saved in binary format.
- The data that is saved can be loaded to display the waveform and compute numeric data.  
If saved data is loaded, the accumulate setting is always turned OFF.
- A header file that is used when analyzing the waveform on a PC is automatically created. The header file cannot be opened on the DL750/DL750P. For details on the header file format, see appendix 4, "ASCII Header File Format."
- The extension is .WVF. The extension of the header file name is .HDR.
- When saving waveform data in binary format, a header file is automatically created with the extension .HDR. When the DL750/DL750P is used to copy, delete, change filenames, or change file attribute of waveform data files (files with .WVF extension), the header files are automatically updated to reflect the changes. Do not delete only the header file or only the waveform data file, as this may cause a system malfunction.
- Waveforms measured using the dual capture function are saved simultaneously to the main waveform data file and sub waveform data file (dual capture data file).
  - The sub waveform data file is automatically saved to a file name that results by adding two characters "DC" to the file name of the main waveform data file.
  - The sub waveform data file is loaded at the same time the main waveform data is loaded.
  - You cannot load only the sub waveform data file.
  - Do not delete only the main waveform data file or only the sub waveform data file.

- **ASCII**

- The units of the sampled data in the acquisition memory are converted per the specified range and saved in ASCII format. The data can be used to analyze the waveform on a PC.
- The file cannot be loaded to the DL750/DL750P.
- The extension is .CSV.
- Waveforms measured using the dual capture function are saved simultaneously to the main data file and dual capture data file. The dual capture data file is automatically saved to a file name that results by adding two characters "DC" to the file name of the main data file.
- If the file size exceeds 2 GB depending on the combination of the record length and the number of channels, the files cannot be created.

- **Float**

- The units of the sampled data in the acquisition memory are converted per the specified range and saved in 32-bit floating format. The data can be used to analyze the waveform on a PC.
- The order of the data is little-endian (Intel format).
- The file cannot be loaded to the DL750/DL750P.
- The extension is .FLD.
- Waveforms measured using the dual capture function are saved simultaneously to the main data file and dual capture data file. The dual capture data file is automatically saved to a file name that results by adding two characters "DC" to the file name of the main data file.
- If the file size exceeds 2 GB depending on the combination of the record length and the number of channels, the files cannot be created.

**Data Size**

The following table shows the data size when the record length is set to 100 kW, waveform data of CH1 to CH4 are saved, all Math channels are turned OFF, and using history waveform 1 condition.

Data Type	Extension	Data Size (Bytes)
Binary	.WVF	Approx. 800 K $((100 \text{ kW} + 32) \times 4 \text{ channels} \times \text{the number of history waveforms} \times 2)$
	.HDR	Approx. 2 K (approx. 3 K when Math1 and Math2 are ON)
ASCII	.CSV	4 to 5 MW
Float	.FLD	Approx. 1.6 M $((100 \text{ kW} + 32) \times 4 \times \text{the number of history waveforms} \times 4)$

**Waveform to Be Saved: Trace**

- You can save all the waveforms or the specified waveforms from CH1 to CH16, DSP1 to DSP6 (optional), Math waveforms, logic waveforms, and event waveforms.
- The setup parameters including vertical axis, horizontal axis, and trigger of the waveform to be saved are also saved.
- For waveforms that are loaded using the history memory function, you can select whether to save all of the history data, save the average of the history data, or save just the current displayed waveform on the screen. If History is set to All, MATH channels are not saved. If you wish to save the data of MATH channels, set History to One. You can also save only the results obtained by searching the history memory data. For a description of searching the history memory data, see section 11.2.
- For a description of snapshot waveforms, see section 13.9.

**Selecting the Range of the Waveform to Be Saved**

Select the range (region) of the waveform from the following list of choices. Only the data that has been saved by selecting Binary in the aforementioned section "Selecting the Data Type" can be loaded in the DL750/DL750P.

- Main**  
The range of the normal (Main) waveform. It is the range defined by the displayed record length (range displayed on the screen).
- Z1**  
The range of zoom waveform Z1.
- Z2**  
The range of zoom waveform Z2.

**Compressing the Data and Saving: P-P Comp (When Data Type Is Set to Binary)**

You can select whether to P-P compress the waveform data before saving. Power spectrum computation data cannot use P-P compression.

**Decimating the Data and Saving: Save Interval (When Date Type Is Set to ASCII)**

When saving to ASCII format, data is decimated and converted to ASCII format before the data is saved.

Save Interval: OFF (no decimation), Per 5, Per 10, Per 20, Per 50, Per 100, Per 200, Per 500, Per 1000, Per 2000, and Per 5000

For example, if Per 5 is selected, the data is decimated as follows.

"First data point" "+5" "+10" "+15" ...

**Selecting the Storage Medium and Directory**

Media on which saving and loading are possible are displayed on the File List window.

• **Display Examples of Storage Media**

- [FD]: Floppy disk
- [ZIP]: Zip disk
- [PC Card]: PC card
- [HD]: Hard disk
- [SCSI5]: SCSI device with the ID number set to 5<sup>1</sup>
- [SCSI5-1]: Partition 1 of a SCSI device whose ID number is 5<sup>1</sup>
- [NetWork]: Network drive (when the Ethernet interface option is installed)
- [USB]: USB storage device

1. When a SCSI device whose ID number is 5 is connected

**Setting the File Name**

You can specify the file name using up to 16 characters. The characters that can be used are 0-9, A-Z, %, \_, (, and ).

• **Auto Naming**

Select from the following three types.

- OFF: The name specified by File Name is attached.
- Numbering: Files are automatically named with four digit numbers from 0000 to 4999. You can specify a common name (up to four characters, specified by File Name) that is placed before the number.
- Date: Files are automatically named using 8 characters (base 36 consisting of 0 to 9 and A to Z) based on the date and time. (The file name specified by File Name is void.)

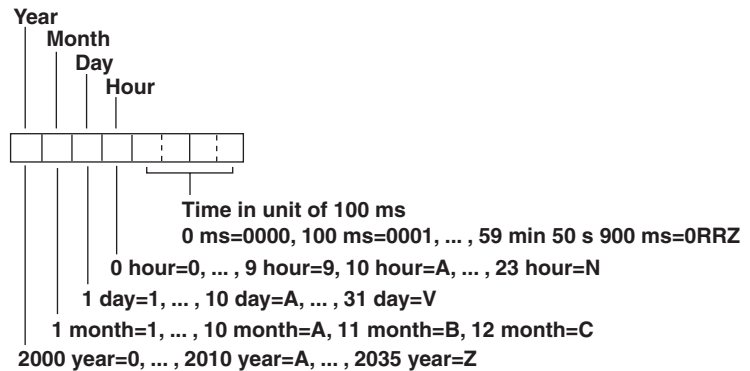

**Note**

Up to 16 characters can be entered for the common name. Characters exceeding 16 characters are void.

• **Setting a Comment**

A comment of up to 160 characters can be added and saved. Comments are optional. All characters (including spaces) can be used.

**Specifying the File to Be Displayed on the File List Window: Filter**

Specify the type of files to be displayed.

- \*.WVF/\*.CSV/\*.FLD: Displays only the files that have the same file format as the file being saved.
- \*.\*: Displays all the files in the medium/directory.

**Property**

Displays the following information about the selected file: filename.extension, the file size, the date/time the file was saved, the attribute, the comment, the presence of voice memo, the module configuration when the file was saved, the conditions for saving, etc.

**Note**

- An error occurs, if a key other than the Abort key is pressed while saving or loading a file.
- Saving and Loading is not possible while data acquisition is in progress. If waveform data is loaded, the accumulate setting is always turned OFF.
- If you change the extension of the saved data such as on a PC, the file can no longer be loaded.
- Up to 36 characters can be displayed in "Path."
- File names are not case-sensitive. Comments are case-sensitive. In addition, the following five file names cannot be used due to limitations of MS-DOS. AUX, CON, PRN, NUL, CLOCK, COM1 to COM9, and LPT1 to LPT9
- The waveform data loaded from a file overwrites the data in the acquisition memory. Once the memory is overwritten, the old data cannot be recovered. It is recommended that the current waveform data be saved before loading data from a file.
- If the total number of files and directories exceed 5000 in a single directory, the file list is no longer displayed.
- This function cannot be used when using the FTP server function, network printer function, or the Web server function.
- Waveform (.wvf) and header (.hdr) files are saved as file pairs. If you specify "\*.\*" for the files to be displayed (Filter) on the File List and manipulate individual files (Delete, Rename, or Copy), the file can no longer be loaded.
- Files that do not have an archive attribute are not displayed in the File List window. Do not remove the archive attribute of the files saved by the DL750/DL750P using your PC.

**Data Format When Storing Multiple Records**

When multiple records are stored (history memory, for example), the following data format is used.

**ASCII Format: CR+LF is inserted between records.**

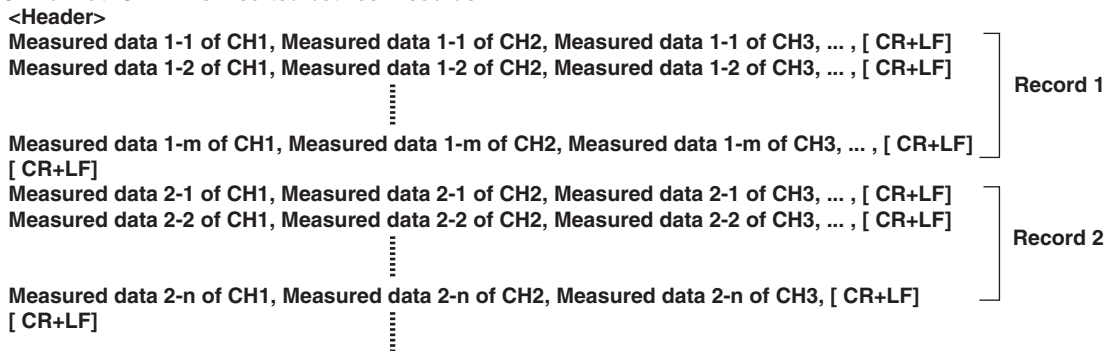

**Float Format: Stored in blocks of channels.**

Measured data of record 1 of CH1
Measured data of record 2 of CH1
⋮
Measured data of record N of CH1
Measured data of record 1 of CH2
Measured data of record 2 of CH2
⋮
Measured data of record N of CH2
⋮

# 13.8 Saving/Loading the Setup Data

<For a description of this function, refer to page 2-64.>



## CAUTION

Never remove the storage medium (disk) or turn OFF the power while the access indicator or the floppy disk, Zip disk, or internal hard disk (optional) icon is blinking. Such acts can damage the storage medium or destroy the data on the medium.

### Procedure

#### Saving the Setup Data

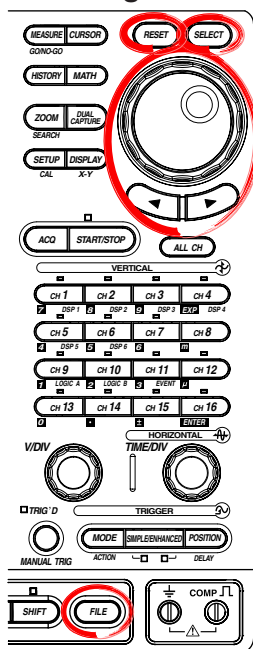

1. Press **FILE**.
2. Press the **File Item** soft key. The File Item setup menu appears.
3. Press the **Setup** soft key.

#### Selecting Save Destination Medium

4. Press the **Save** soft key. The save setup menu appears.
5. Press the **File List** soft key. The File List window appears.
6. Turn the **jog shuttle** to select the save destination medium (indicated by brackets).
7. Press **SELECT** to confirm the storage medium.

#### Selecting the Destination Directory

(Perform this operation when directories are present on the medium.)

8. Turn the **jog shuttle** to select the save destination directory (indicated by < >).
9. Press **SELECT** to confirm the directory. The selected medium/directory is displayed in "Path=....." located above and to the left of the File List window. Select <..> to move to the parent directory.

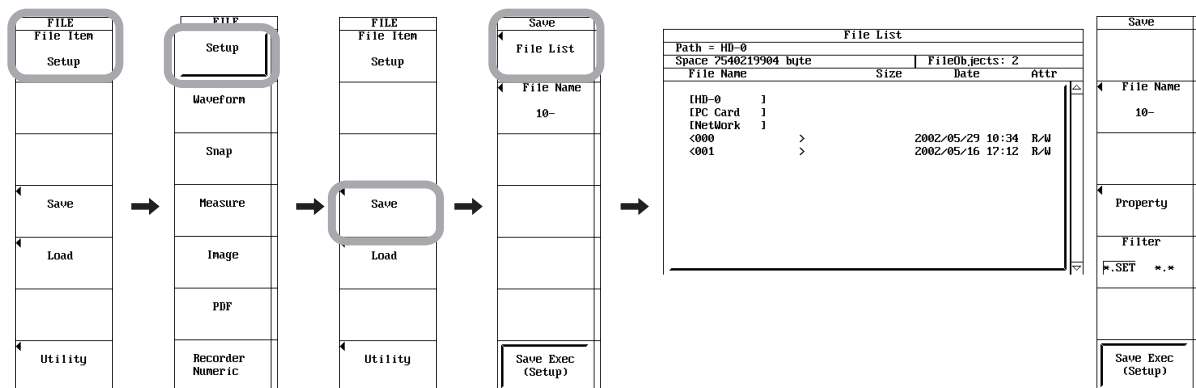



### Setting the File Name and Comment







10. Press the **File Name** soft key. The file name setup menu appears.
11. Turn the **jog shuttle** to select Auto Naming.
12. Press **SELECT** to select OFF, Numbering, or Date.
13. Turn the **jog shuttle** to select File Name.
14. Enter the file name using up to 16 characters according to the procedure given in section 4.2.
15. Turn the **jog shuttle** to select Comment.
16. Enter the comment using up to 160 characters according to the procedure given in section 4.2.

### Note

You can set up to 16 characters for the file name, but only 15 characters are displayed on the setup menu.

### Executing the Save Operation

17. Press the **Save Exec** soft key. The data is saved to the directory indicated by Path=..... At the same time, the **Save Exec** soft key changes to an **Abort** soft key.

While the data is being saved, an icon corresponding the save destination medium (  FD,  Zip disk,  PC card,  external SCSI device,  internal HD, or  USB storage device) is displayed at the upper left corner of the screen.

### Aborting the Save Operation

18. Press the **Abort** soft key. The save operation is aborted. At the same time, the **Abort** soft key changes to a **Save Exec** soft key.

### Specifying the File to Be Displayed on the File List window

19. On the screen showing the File List window, press the **Filter** soft key to select \*.SET or \*.\*.
20. Turn the **jog shuttle** to select the files in the File List window.

### Displaying Properties

21. Press the **Property** soft key. Information about the selected file is displayed.

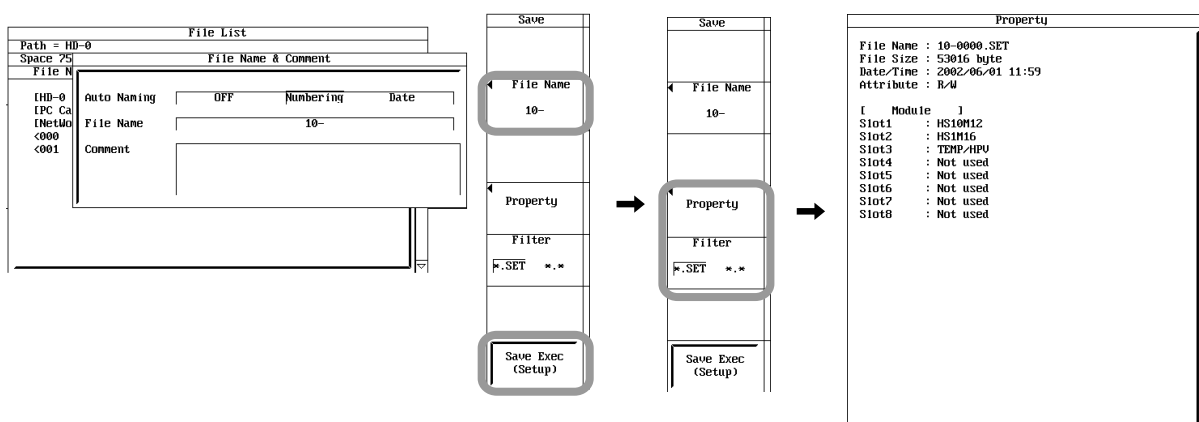

**Loading the Setup Data**

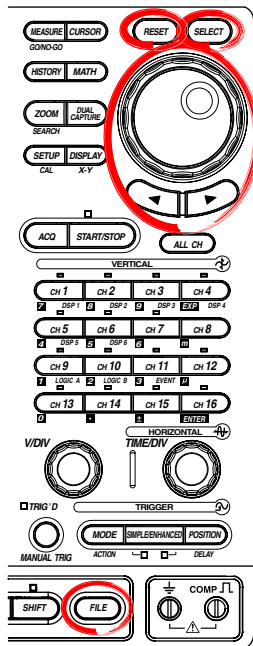

1. Press **FILE**.
2. Press the **File Item** soft key. The File Item setup menu appears.
3. Press the **Setup** soft key.

**Selecting the Load Source Medium/Directory**

4. Press the **Load** soft key. The load setup menu and File List window appear.
5. Select the load source directory according to steps 4 to 9 in “Saving the Setup Data.”

**Selecting the File to Be Loaded**

6. Turn the **jog shuttle** to select the file.

**Executing the Load Operation**

7. Press the **Load Exec** soft key. A dialog box appears showing the module information of the selected setup data and the current module information of the DL750/DL750P.
8. Press the **Load Exec** soft key again. The selected file is read from the directory indicated in Path=..... At the same time, the **Load Exec** soft key changes to an **Abort** soft key.

**Note**

If the module information of the setup data and the current module information of the DL750/DL750P differ, the setup data cannot be loaded.

**Aborting the Load Operation**

9. Press the **Abort** soft key. The load operation is aborted. At the same time, the **Abort** soft key changes to a **Load Exec** soft key.

**Specifying the Files to Be Displayed in the File List Window and Displaying Properties**

10. Carry out steps 19 to 21 in “Saving the Setup Data.”

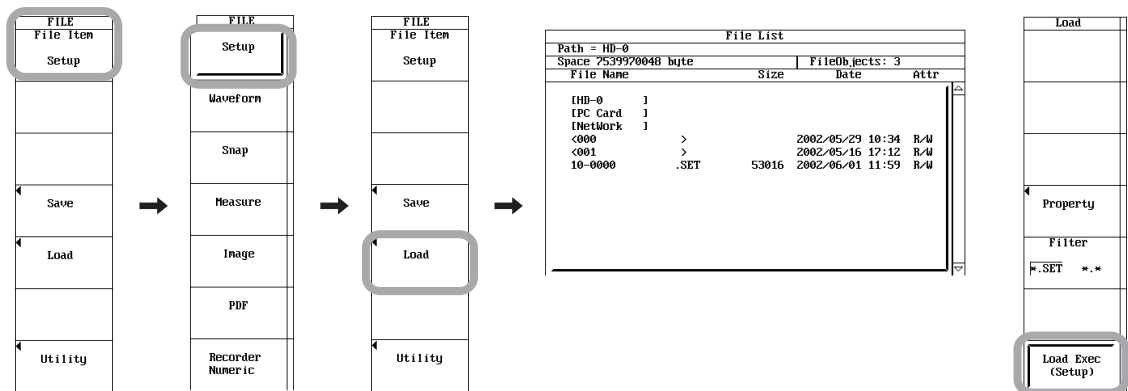

Explanation

Setup Parameters That Are Saved

The setup parameter of each key existing at the time of the save operation can be saved. However, setup parameters such as the date and time, communications, and SCSI ID numbers are not saved.

Number of Bytes Needed in Saving Setup Data

Approx. 64 KB

Selecting the Storage Medium and Directory: File List

Media on which saving and loading are possible are displayed on the File List window.

Display Examples of Storage Media

- [FD]: Floppy disk
- [ZIP]: Zip disk
- [PC Card]: PC card
- [HD]: Internal hard disk
- [SCSI5]: SCSI device with the ID number set to 5<sup>1</sup>
- [SCSI5-1]: Partition 1 of a SCSI device whose ID number is 5<sup>1</sup>
- [NetWork]: Network drive (when the Ethernet interface option is installed)
- [USB]: USB storage device

1. When a SCSI device whose ID number is 5 is connected

Setting the File Name

You can specify the file name using up to 16 characters. The characters that can be used are 0-9, A-Z, %, \_, (, and ).

Auto Naming

Select from the following three types.

- OFF: The name specified by File Name is attached.
- Numbering: Files are automatically named with four digit numbers from 0000 to 4999. You can specify a common name (up to four characters, specified by File Name) that is placed before the number.
- Date: Files are automatically named using 8 characters (base 36 consisting of 0 to 9 and A to Z) based on the date and time. (The file name specified by File Name is void.)

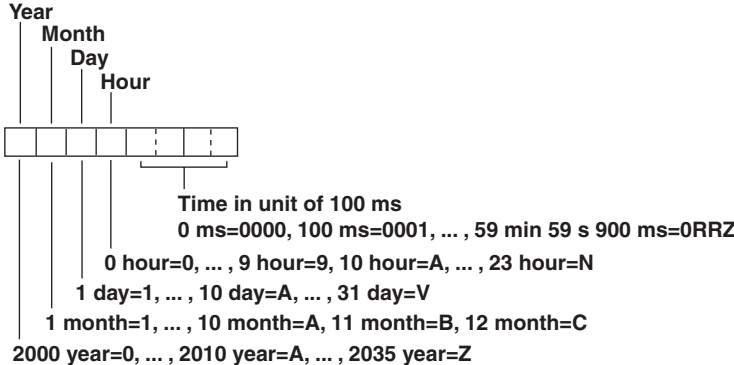

Note

Up to 16 characters can be entered for the common name. Characters exceeding 16 characters are void.

Setting a Comment

A comment of up to 160 characters can be added and saved. Comments are optional. All characters (including spaces) can be used.

### **Notes When Saving Setup Data**

- You cannot save setup data while waveform acquisition is in progress. Press START/STOP to stop the acquisition first.
- The number of directories and files that is displayed in the file list is up to 5000. If the number of directories and files in a directory exceeds 5000, the file list displays 5000 directories and files, but the ones that are displayed cannot be determined.

### **Extension of Setup Data**

A .set extension is automatically attached to the file name.

### **Specifying the File to Be Displayed on the File List Window: Filter**

Specify the type of files to be displayed.

- \*.SET: Displays only setup data files.
- \*.\*: Displays all the files in the medium/directory.

### **Property**

Displays the following information about the selected file: filename.extension, the file size, the date the file was saved, the attribute, the comment, and the module configuration when the file was saved, etc.

### **Note**

- An error occurs, if a key other than the Abort key is pressed while saving or loading a file.
  - Saving and Loading is not possible while data acquisition is in progress.
  - If you change the extension of the file such as on a PC, the file can no longer be loaded.
  - Up to 36 characters can be displayed in "Path."
  - File names are not case-sensitive. Comments are case-sensitive. In addition, the following five file names cannot be used due to limitations of MS-DOS. AUX, CON, PRN, NUL, CLOCK, COM1 to COM9, and LPT1 to LPT9
  - If the setup parameters that are saved to a file are loaded, the key settings are changed to the loaded information and cannot be undone. It is recommended that you first save the current setup parameters and then load the setup parameters from a file.
  - Setup parameters such as the date and time, communications, SCSI ID numbers, menu language, message language, and USB keyboard language are not saved. Therefore, loading setup parameters from a file will not change these settings.
  - This function cannot be used when using the FTP server function, network printer function or the Web server function.
  - Files that do not have an archive attribute are not displayed in the File List window. Do not remove the archive attribute of the files saved by the DL750/DL750P using your PC.
-

# 13.9 Saving/Loading Snapshot Waveforms

<For a description of this function, refer to page 2-64.>

## CAUTION

Never remove the storage medium (disk) or turn OFF the power while the access indicator or the floppy disk, Zip disk, or internal hard disk (optional) icon is blinking. Such acts can damage the storage medium or destroy the data on the medium.

### Procedure

#### Saving Snapshot Waveforms

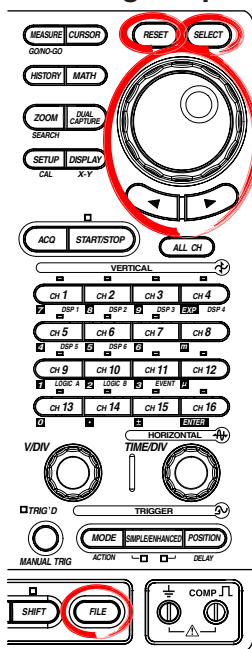

1. Press **FILE**.
2. Press the **File Item** soft key. The File Item setup menu appears.
3. Press the **Snap** soft key.

#### Selecting Save Destination Medium

4. Press the **Save** soft key. The save setup menu appears.
5. Press the **File List** soft key. The File List window appears.
6. Turn the **jog shuttle** to select the save destination medium (indicated by brackets).
7. Press **SELECT** to confirm the storage medium.

#### Selecting the Destination Directory

- (Perform this operation when directories are present on the medium.)
8. Turn the **jog shuttle** to select the save destination directory (indicated by < >).
  9. Press **SELECT** to confirm the directory. The selected medium/directory is displayed in "Path=....." located above and to the left of the File List window. Select <..> to move to the parent directory.

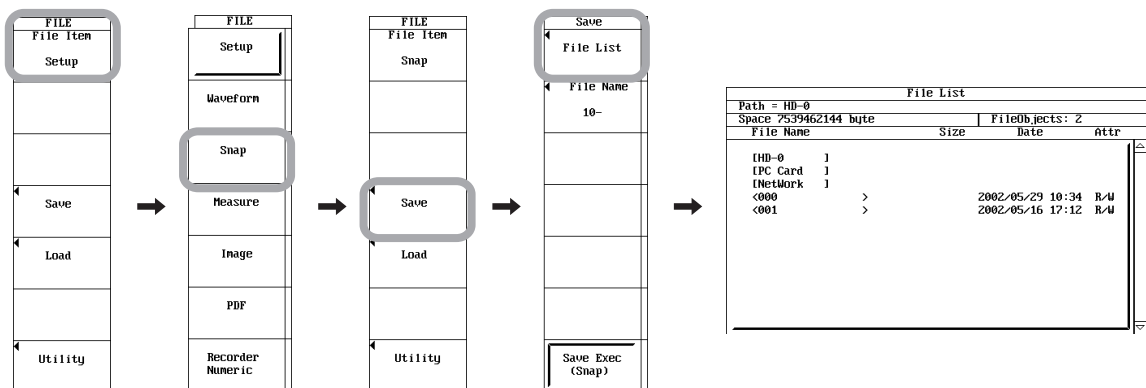

## 13.9 Saving/Loading Snapshot Waveforms

### Setting the File Name and Comment

10. Press the **File Name** soft key. The file name setup menu appears.
11. Turn the **jog shuttle** to select Auto Naming.
12. Press **SELECT** to select OFF, Numbering, or Date.
13. Turn the **jog shuttle** to select File Name.
14. Enter the file name using up to 16 characters according to the procedure given in section 4.2.
15. Turn the **jog shuttle** to select Comment.
16. Enter the comment using up to 160 characters according to the procedure given in section 4.2.

### Note

You can set up to 16 characters for the file name, but only 15 characters are displayed on the setup menu.

### Executing the Save Operation

17. Press the **Save Exec** soft key. The data is saved to the directory indicated by Path=..... At the same time, the **Save Exec** soft key changes to an **Abort** soft key.

### Aborting the Save Operation

18. Press the **Abort** soft key. The save operation is aborted. At the same time, the **Abort** soft key changes to a **Save Exec** soft key.  
While the data is being saved, an icon corresponding the save destination medium (FD, Zip disk, PC card, external SCSI device, internal HD, or USB storage device) is displayed at the upper left corner of the screen.

### Specifying the File to Be Displayed on the File List Window

19. On the screen showing the File List window, press the **Filter** soft key to select \*.SNP or \*.\*.
20. Turn the **jog shuttle** to select the files in the File List window.

### Displaying Properties

21. Press the **Property** soft key. Information about the selected file is displayed.

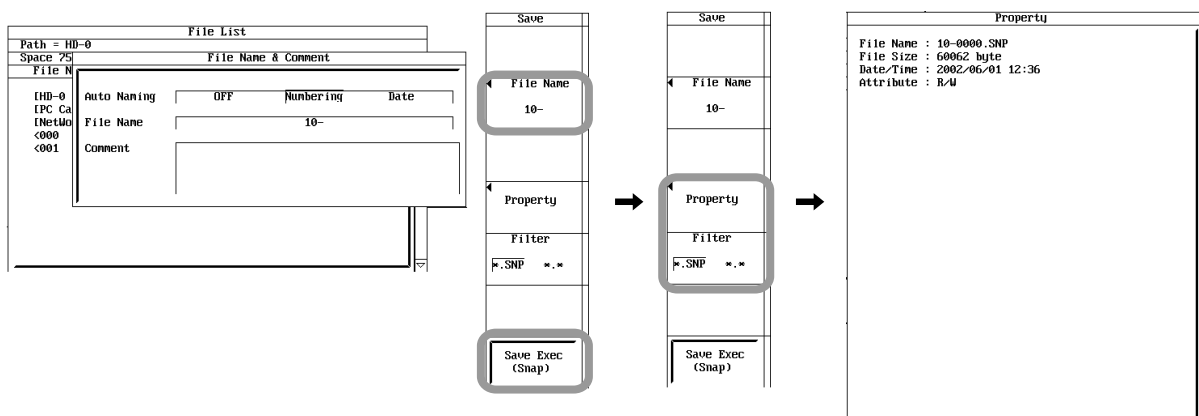

### Loading Snapshot Waveforms

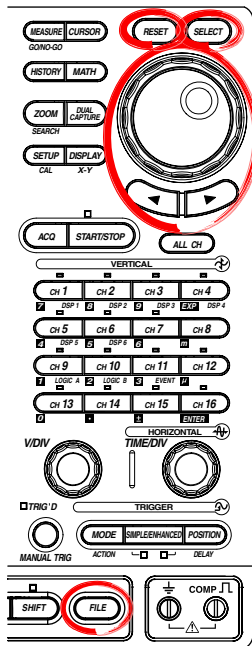

1. Press **FILE**.
2. Press the **File Item** soft key. The File Item setup menu appears.
3. Press the **Snap** soft key.

#### Selecting the Load Source Medium/Directory

4. Press the **Load** soft key. The load setup menu and File List window appear.
5. Select the load source directory according to steps 4 to 9 in "Saving Snapshot Waveforms."

#### Selecting the File to Be Loaded

6. Turn the **jog shuttle** to select the file.

#### Executing the Load Operation

7. Press the **Load Exec** soft key. The selected file is read from the directory indicated in Path=..... At the same time, the **Load Exec** soft key changes to an **Abort** soft key.

#### Aborting the Load Operation

8. Press the **Abort** soft key. The load operation is aborted. At the same time, the **Abort** soft key changes to a **Load Exec** soft key.

#### Specifying the Files to Be Displayed in the File List Window and Displaying Properties

9. Carry out steps 19 to 21 in "Saving Snapshot Waveforms."

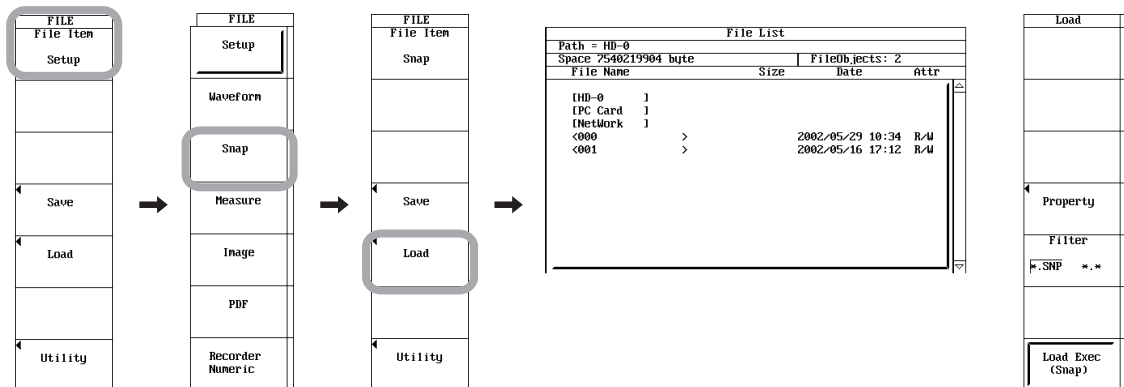

### ***Explanation***

You can take snap shots of the waveform and save the image to the file. You can also load the snapshot waveform.

#### **Data Size**

Approx. 60 KB

#### **Data Extension**

The extension is .SNP.

The selection of the medium and directory, file name, auto naming function, comments, specification of the files to be displayed in the File List window, and properties are the same as those for saving/loading normal waveform data.

For details, see section 13.7, "Saving/Loading the Waveform Data."

#### **Clearing the Waveform**

The loaded snapshot waveform is cleared when CLEAR TRACE or initialization is performed.

#### **Note**

- An error occurs, if a key other than the Abort key is pressed while saving or loading a file.
  - This function cannot be used when using the FTP server function, network printer function, or the Web server function.
-



# 13.10 Saving the Results of the Automated Measurement of Waveform Parameters

<For a description of this function, refer to page 2-64.>

## CAUTION

Never remove the storage medium (disk) or turn OFF the power while the access indicator or the floppy disk, Zip disk, internal hard disk (optional), or USB storage device icon is blinking. Such acts can damage the storage medium or destroy the data on the medium.

### Procedure

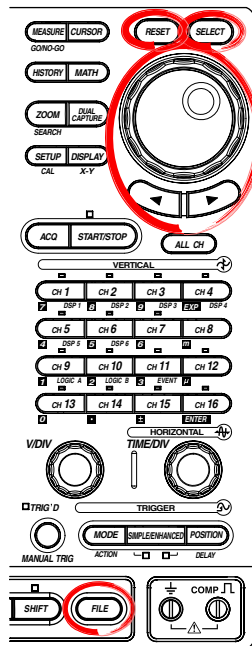

1. Press **FILE**.
2. Press the **File Item** soft key. The File Item setup menu appears.
3. Press the **Measure** soft key.

### Selecting Save Destination Medium

4. Press the **Save** soft key. The save setup menu appears.
5. Press the **File List** soft key. The File List window appears.
6. Turn the **jog shuttle** to select the save destination medium (indicated by brackets).
7. Press **SELECT** to confirm the storage medium.

### Selecting the Destination Directory

- (Perform this operation when directories are present on the medium.)
8. Turn the **jog shuttle** to select the save destination directory (indicated by <>).
  9. Press **SELECT** to confirm the directory. The selected medium/directory is displayed in "Path=....." located above and to the left of the File List window. Select <..> to move to the parent directory.

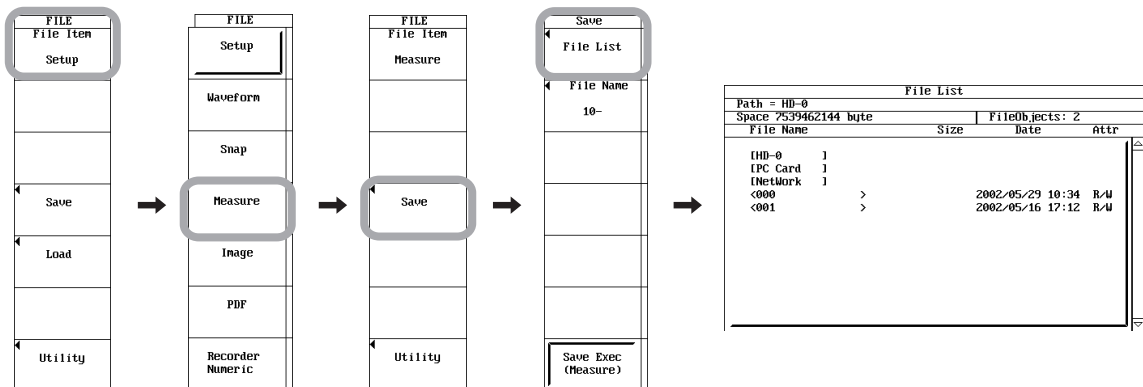

## 13.10 Saving the Results of the Automated Measurement of Waveform Parameters

### Setting the File Name and Comment

10. Press the **File Name** soft key. The file name setup menu appears.
11. Turn the **jog shuttle** to select Auto Naming.
12. Press **SELECT** to select OFF, Numbering, or Date.
13. Turn the **jog shuttle** to select File Name.
14. Enter the file name using up to 16 characters according to the procedure given in section 4.2.
15. Turn the **jog shuttle** to select Comment.
16. Enter the comment using up to 160 characters according to the procedure given in section 4.2.

### Executing the Save Operation

17. Press the **Save Exec** soft key. The data is saved to the directory indicated by Path=..... At the same time, the **Save Exec** soft key changes to an **Abort** soft key.  
While the data is being saved, an icon corresponding the save destination medium (FD, Zip disk, PC card, external SCSI device, internal HD, or USB storage device) is displayed at the upper left corner of the screen.

### Aborting the Save Operation

18. Press the **Abort** soft key. The save operation is aborted. At the same time, the **Abort** soft key changes to a **Save Exec** soft key.

### Specifying the File to Be Displayed on the File List Window

19. On the screen showing the File List window, press the **Filter** soft key to select \*.CSV or \*.\*.
20. Turn the **jog shuttle** to select the files in the File List window.

### Displaying Properties

21. Press the **Property** soft key. Information about the selected file is displayed.

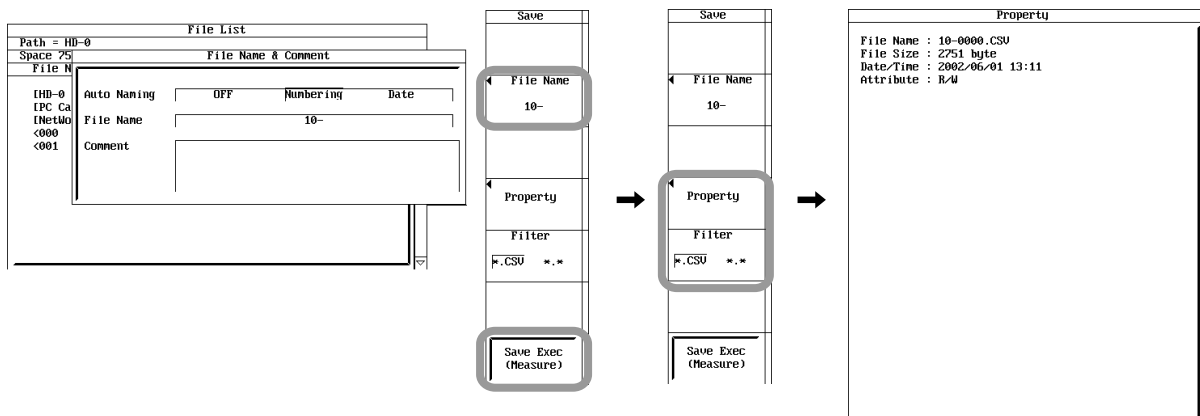

**Explanation**

The results of the automated measurement of waveform parameters can be saved in CSV format (.CSV extension) to a floppy disk, a Zip disk, a PC card, an external SCSI device, the internal hard disk (optional), or the USB storage device.

A CSV file is a comma-separated format file. The CSV file is one of the common file formats used to exchange data between spreadsheet and database applications.

The data that are saved are the measured results of the parameters that are specified in the automated measurement of waveform parameters.

**Notes When Saving the Results of the Automated Measurement of Waveform Parameters**

The restrictions are as follows.

- Up to (48000/the number of items that are turned ON) data points before the point at which the save operation is executed are saved. However, the data points that are saved are limited to those that are acquired after fixing T/div, record length, and Measure settings.

**Output Example**

"CH1 P-P",	"CH1 Max",	"CH1 Min",	"CH2 P-P"	
"V",	"V",	"V",	"V",	
0.500E+00,	0.500E+00,	0.000E+00,	0.02E-06	Oldest data
0.375E+00,	0.375E+00,	0.000E+00,	0.02E-06	
0.313E+00,	0.188E+00,	-0.125E+00,	0.02E-06	
•	•	•	•	↓
•	•	•	•	
•	•	•	•	
•	•	•	•	Newest data

For a description of the automated measurement of waveform parameters, see section 8.2.

**Data Size**

The data size can be derived from the following equation.

Data size = the number of items × 15 × the number of history waveforms (bytes)

**Data Extension**

The extension is .CSV.

The selection of the medium and directory, file name, comments, auto naming function, specification of the files to be displayed in the File List window, and properties are the same as those for saving/loading normal waveform data.

For details, see section 13.7, "Saving/Loading the Waveform Data."

**Note**

- An error occurs, if a key other than the Abort key is pressed while saving a file.
- This function cannot be used when using the FTP server function, network printer function, or the Web server function.
- If you change the measurement conditions after performing automated measurement of waveform parameters, the measured results are cleared. At this point, the measured results after the change are displayed on the screen, but they cannot be saved to a file.
- If waveform parameters are measured while the sub waveform window of the dual capture function is showing, the waveform parameters shown in the sub waveform window are measured. Therefore, if you set the trigger mode to Log and change Capture Num (waveform number displayed in the sub waveform window) while making measurements using the dual capture function, the measurement results of waveform parameters become misaligned with the waveform numbers. If you wish to save the results of the automated measurement of waveform parameters after changing Capture Num, execute History statistics to align the measurement results of waveform parameters with the waveform numbers before saving the data.

# 13.11 Saving Screen Image Data

<For a description of this function, refer to page 2-63.>

## Procedure

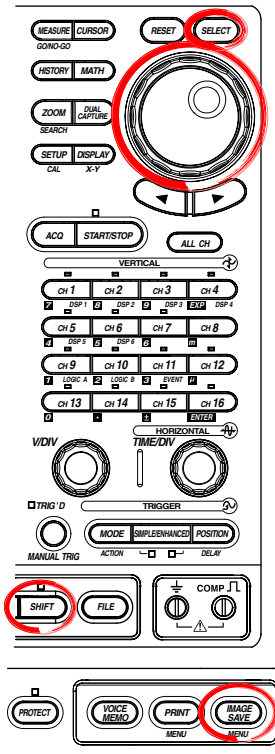

1. Press **SHIFT+IMAGE SAVE**.

### Selecting the Output Format

2. Press the **Format** soft key.
3. Press the soft key corresponding to the desired output format from PNG, JPEG, BMP, and Post Script.

### Setting the Color (When Format Is PNG, JPEG, or BMP)

4. Press the **Color** soft key to select ON, ON(Revers), ON(Gray), or OFF.

### Setting the Compression Format (When Format Is BMP and Color Is Not OFF)

5. Press the **Compression** soft key to select ON or OFF.

### Setting a Comment

5. Press the **Comment** soft key.
6. Enter the comment using up to 20 characters according to the procedure given in section 4.2.

### Selecting Save Destination Medium

7. Press the **File List** soft key. The save destination File List window appears.
8. Turn the **jog shuttle** to select the save destination storage medium.

### Note

Storage media such as the built-in floppy disk, Zip disk, PC card, internal HD (option), external SCSI device, and USB storage device are displayed in brackets.

- Floppy disk [FD]
- Zip disk [ZIP]
- PC card [PC Card]
- Internal hard disk [HD]
- External SCSI device [SCSI]
- USB storage device [USB]

Directories are displayed using < >.

9. Press **SELECT**. The contents of the selected storage medium or directory are displayed.

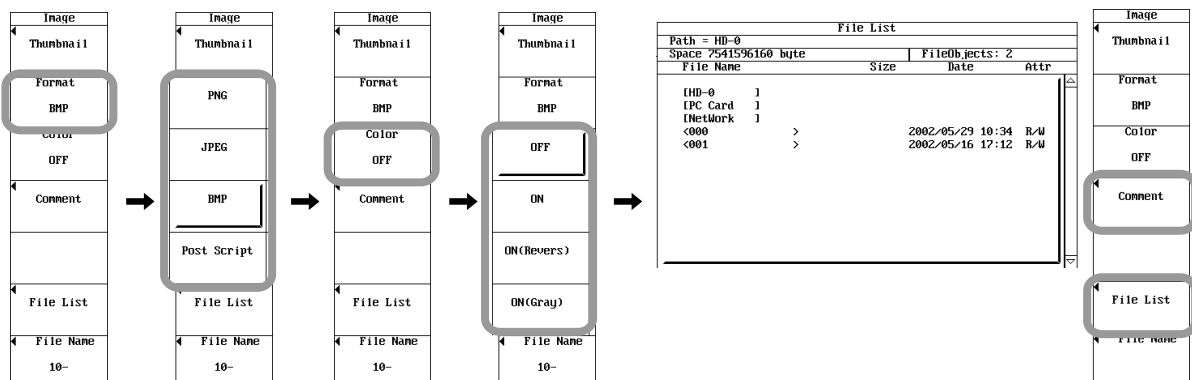

### Selecting the Destination Directory

(Perform this operation when directories are present on the medium.)

10. Turn the **jog shuttle** to select the save destination directory (indicated by < >).
11. Press **SELECT** to confirm the new directory. The selected medium/directory is displayed in "Path=....." located above and to the left of the File List window. Select <..> to move to the parent directory.

### Setting the Name of the File to Be Saved

12. Press the **File Name** soft key. The file name setup menu appears.
13. Turn the **jog shuttle** to select Auto Naming.
14. Press **SELECT** to select OFF, Numbering, or Date.
15. Turn the **jog shuttle** to select File Name.
16. Enter the file name using up to 16 characters according to the procedure given in section 4.2.

### Note

- If Auto Naming is set to Numbering, the first four characters are valid. If Auto Naming is set to Date, the file name is invalid.
- You can set up to 16 characters for the file name, but only 15 characters are displayed on the setup menu.
- When saving screen image data, voice comment data can be saved along with the screen image data. For details, see section 13.19, "Using the Voice Comment Function."

### Executing the Save Operation

17. Press **IMAGE SAVE**. The screen image data is saved to the storage medium. Pressing **IMAGE SAVE** again aborts the save operation. While the data is being saved, an icon corresponding the save destination medium (FD, Zip disk, PC card, external SCSI device, internal HD, or USB storage device) is displayed at the upper left corner of the screen.

### Note

Thumbnails of the saved screen image data can be displayed. For details, see section 13.12.

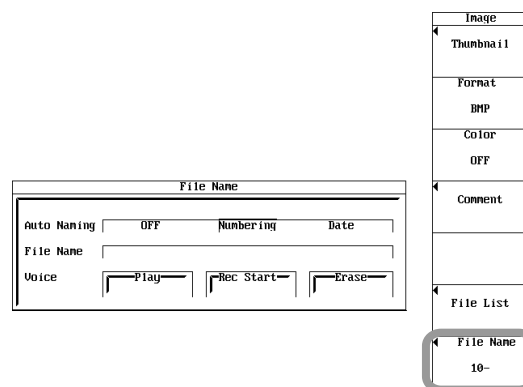

### **Explanation**

The screen image data can be stored to a specified storage medium. You can select the storage medium from the floppy disk, Zip disk, PC card, external SCSI device, internal hard disk (optional), and network drive (when the Ethernet interface option is installed). For details on saving data to the network drive, see section 16.3.

### **Setting the Output Format**

Data in the following formats can be saved to a specified storage medium. The extension that is automatically attached and the file size (reference value) are indicated below.

Output Data Format	Extension	File Size <sup>1</sup>
PNG	*.PNG	Approx. 6 kbytes (Approx. 14 kbytes) <sup>2</sup>
JPEG	*.JPG	Approx. 400k bytes (Approx. 400 kbytes) <sup>2</sup>
BMP	*.BMP	Approx. 60 kbytes (Approx. 480 kbytes) <sup>2</sup>
Post Script	*.PS	Approx. 123 kbytes

1. When color is OFF
2. The file size inside the parentheses is for the case when color is ON

### **Setting the Color (When Format Is BMP)**

Select ON, ON(Revers), ON(Gray), or OFF.

- ON: Output using 256 colors.  
ON(Revers): Do not output the background of the screen in color.  
ON(GRAY): Output the data using a tint of 16 gray levels.  
OFF: Output in black and white.

### **Setting the Compression Format (When Format Is BMP and Color Is Not OFF)**

When the output format is set to BMP, the data can be output by compressing using RLE. However, data compression is not possible if the color is OFF.

### **Setting a Comment**

A comment of up to 20 characters can be added to the lower section of the screen and saved. Comments are optional. All characters (including spaces) can be used.

### **Setting the Save Destination: File List**

The available storage medium is displayed in the File List window.

#### • **Display Examples of Storage Media**

- [FD]: Floppy disk  
[ZIP]: Zip disk  
[PC Card]: PC card  
[HD]: Hard disk  
[SCSI5]: SCSI device with the ID number set to 5<sup>1</sup>  
[SCSI5-1]: Partition 1 of a SCSI device whose ID number is 5<sup>1</sup>  
[NetWork]: Network drive (when the Ethernet interface option is installed)  
[USB]: USB storage device

1. When a SCSI device whose ID number is 5 is connected

### **Floppy Disk, Zip Disk, PC Card, Internal Hard Disk, External SCSI Device, and USB Storage Device**

Floppy disk, Zip disk, PC card, internal hard disk, and external SCSI device are described in sections 13.1 to 13.4. For the formatting procedure, see section 13.5.

### Setting the File Name

You can specify the file name using up to 16 characters. (However, the setup menu displays only up to 15 characters.) The characters that can be used are 0-9, A-Z, %, \_, (, and ).

- **Auto Naming**

Select from the following three types.

- **OFF:** The name specified by File Name is attached.
- **Numbering:** Files are automatically named with four digit numbers from 0000 to 4999. You can specify a common name (up to four characters, specified by File Name) that is placed before the number.
- **Date:** Files are automatically named using 8 characters (base 36 consisting of 0 to 9 and A to Z) based on the date and time. (The file name specified by File Name is void.)

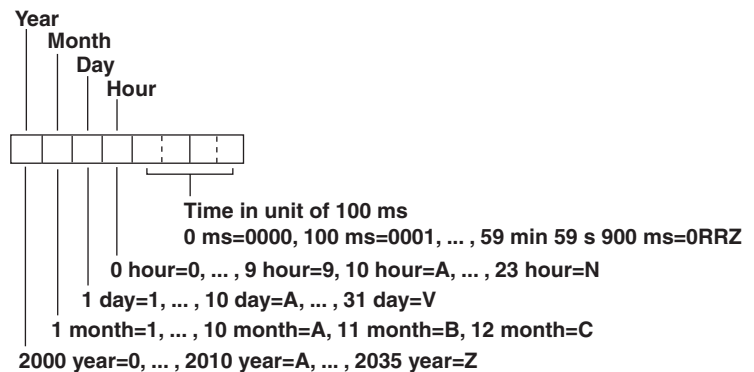

### Note

Up to 16 characters can be entered for the common name. Characters exceeding 16 characters are void.

### Notes When Saving Screen Image Data

- The maximum number of files that can be saved when auto naming is enabled is 5000.
- If the total number of files and directories exceed 5000 in a single directory, the file list is no longer displayed.

### Extension of the Voice Comment Data File

The voice comment function (see section 13.19) can be used to attach a voice comment to screen image data to be saved. The voice comment data is saved as data separate from the screen image data. The extension of the voice comment data file varies depending on the output format of the screen image data to be saved as follows:

- PNG file: .NCM
- JPEG file: .JCM
- BMP file: .BCM
- PS file: .PCM

# 13.12 Displaying Thumbnails of the Saved Screen Image Data

<For a description of this function, refer to page 2-63.>

## Procedure

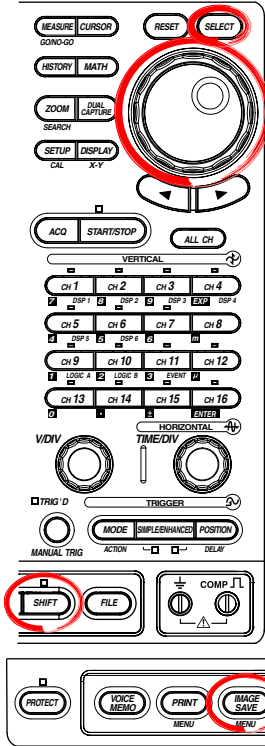

### Thumbnail Display from the IMAGE SAVE Menu

1. Press **SHIFT+IMAGE SAVE**.
  2. Press the **Format** soft key. The save format selection menu appears.
  3. Press the soft key corresponding to the save format of the screen image data of which you wish to display the thumbnails from PNG to PostScript.
- **Displaying the Thumbnails of the Specified Screen Image Data**
    4. Press the **File List** soft key. The File List window appears.
    5. Turn the **jog shuttle** to select the screen image data file in the File List window.
    6. Press **SELECT**. The thumbnail of the selected screen image data file is displayed at the lower right section of the File List window.

When screen image data that has voice comment data is selected, the voice comment is played. For details on the voice comment function, see section 13.19.

To clear the thumbnail, turn the **jog shuttle**.

### Note

- If the selected screen image data file does not have data (file) for thumbnail display, an error message screen appears.
- You can press ESC to clear the thumbnail, but in this case, the File List window is also cleared. To clear only the thumbnail display, turn the jog shuttle.

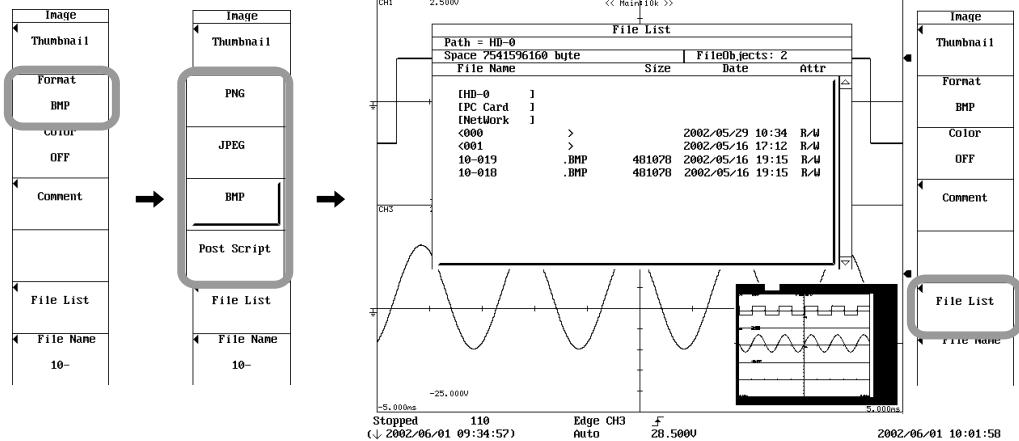



• Listing the Thumbnails of the Specified Format

4. Press the **File List** soft key. The File List window appears.
5. Turn the **jog shuttle** to select the directory that you wish to display the thumbnails.
6. Press the **Thumbnail** soft key. The thumbnails of the screen image data of the format specified in step 3 are displayed (9 thumbnails (3 × 3) in the waveform display area).
7. If there are more than 9 thumbnails, you can scroll the screen using the **jog shuttle**. To scroll the files upward, turn the **jog shuttle** counter-clockwise. To scroll the files downward, turn the **jog shuttle** clockwise. The files scroll three files at a time.
8. To clear the list of thumbnails, press **ESC**.

**Note**

If you set Path=FD (floppy disk drive) on the File List window, a list of thumbnails cannot be displayed.

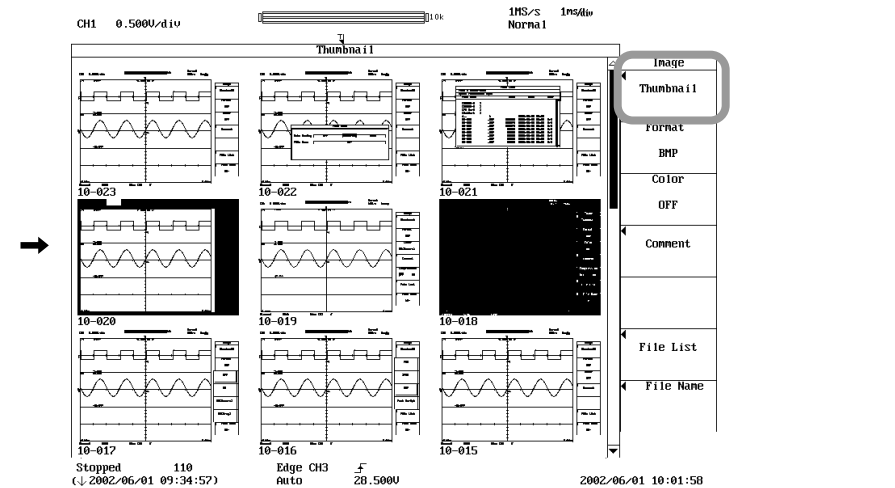
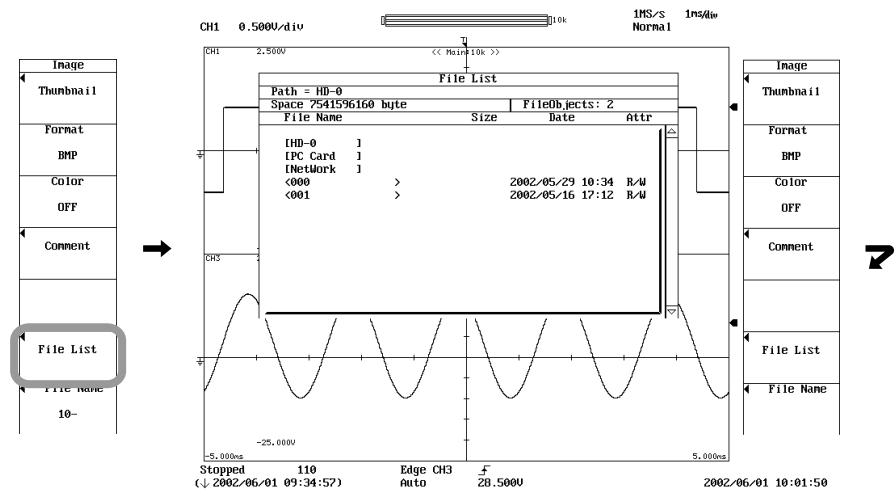

## 13.12 Displaying Thumbnails of the Saved Screen Image Data

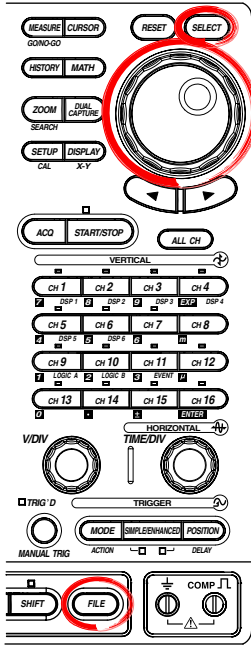

### Thumbnail Display from the FILE Menu

1. Press **FILE**.
2. Press the **File Item** soft key.
3. Press the **Image** soft key.
4. Press the **Format** soft key.
5. Select the format you wish to display thumbnails from PNG to PostScript.
6. Press the **Utility** soft key. The File List window appears.
7. Turn the **jog shuttle** to select the screen image data file (file with .png, .jpg, .bmp, and .ps extensions) on the File List window.
8. Press **SELECT**. The thumbnail of the selected screen image data file is displayed at the lower right section of the File List window.

When screen image data that has voice comment data is selected, the voice comment is played. For details on the voice comment function, see section 13.19.

To clear the thumbnail, turn the **jog shuttle**.

### Note

- If the selected screen image data file does not have data (file) for thumbnail display, an error message screen appears.
- You can press ESC to clear the thumbnail, but in this case, the File List window is also cleared. To clear only the thumbnail display, turn the jog shuttle.

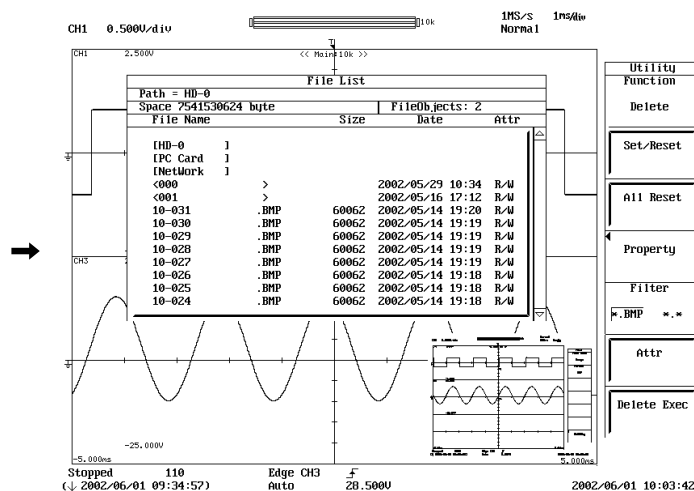
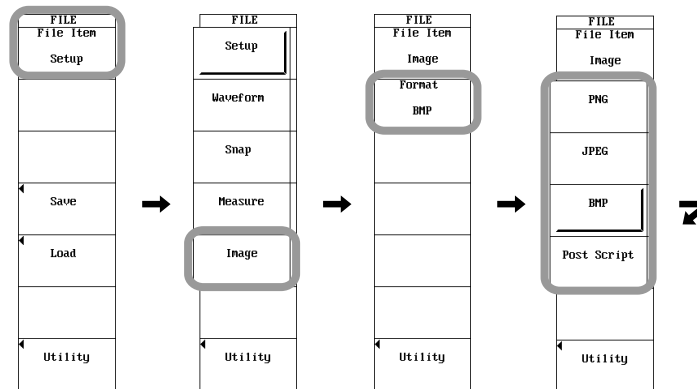

**Explanation**

Thumbnails of the screen image data that are saved on a storage medium can be displayed.

**Thumbnail Display from the IMAGE SAVE Menu**

- **Thumbnail Screen**

Thumbnails are displayed for the screen image data files (files with .png, .jpg, .bmp, and .ps extensions) in the directory selected by File List of the IMAGE SAVE menu. The data used to display thumbnails are separate from the screen image data and are created simultaneously when the screen image data is created. The extension of thumbnail data varies depending on the output format of the original screen image data as follows:

- PNG file: .NTD
- JPEG file: .JTD
- BMP file: .BTD
- PS file: .PTD

The data size is approximately 2 to 6 KB for all formats.

- **Thumbnail Items**

The following two items are displayed.

- Thumbnail of the waveform area
- File name

- **Thumbnail Display Format**

The number of files displayed on the thumbnail screen (the number of thumbnails displayed in the waveform area) is 9. The display order is the same as the order for displaying files in the File List window. In addition, the files are displayed from left to right and top to bottom.

- **Scrolling the Thumbnail Screen**

If the number of thumbnails exceeds the maximum number of thumbnails that can be displayed (9), the thumbnail screen can be scrolled one row (three thumbnails) at a time. To scroll the files upward, turn the jog shuttle counter-clockwise. To scroll the files downward, turn the jog shuttle clockwise.

- **Thumbnails on the File List**

When you select a screen image data file on the File List, the thumbnail of the screen image data is displayed at the lower right section of the File List. The file name is not displayed on the thumbnail screen on the File List.

**Thumbnail Display from the FILE Menu**

When you select a screen image data file on the File List, the thumbnail of the screen image data is displayed at the lower right section of the File List. The file name is not displayed on the thumbnail screen on the File List.

**Note**

The screen image data and thumbnail data are saved in file pairs. For example, if you set the output format to BMP, the following two types of files are saved.

- 0000.BMP (screen image data)
- 0000.BTD (thumbnail data)

If you specify "\*" for the files to be displayed (Filter) on the File List and manipulate individual files (Delete, Rename, or Copy), the thumbnail display function can no longer be used.

# 13.13 Creating PDF Files of the Printed Image (DL750P only)

<For a description of this function, refer to page 2-64.>

## Procedure

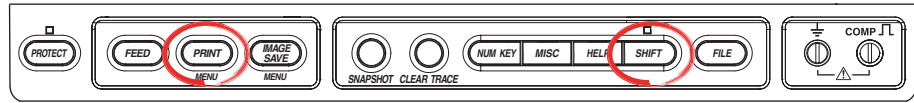

1. Press **SHIFT+PRINT**.

### Selecting the Print Destination

2. Press the **Print to** soft key. The print destination selection menu appears. (Net Print appears only when the Ethernet interface option is installed.)
3. Press the **PDF** soft key.  
When displaying T-Y waveforms, proceed to step 4.  
When displaying X-Y waveforms, proceed to step 8.

### Selecting the Section to Be Output to the PDF File (Only When Displaying the T-Y Waveform)

4. Press the **Time Range1/Time Range2** soft key.
5. Use the **jog shuttle** and **SELECT** to set the output start point and output end point of the section to be output to the PDF file.

### Setting the Print Magnification (Only When Displaying the T-Y Waveform)

6. Press the **Print Mag** soft key.
7. Use the **jog shuttle** to set the print magnification of the waveform when creating the PDF file. The top section of the menu shows the magnification; the bottom section shows the number of pages when the PDF file is created using the magnification indicated in the top section.

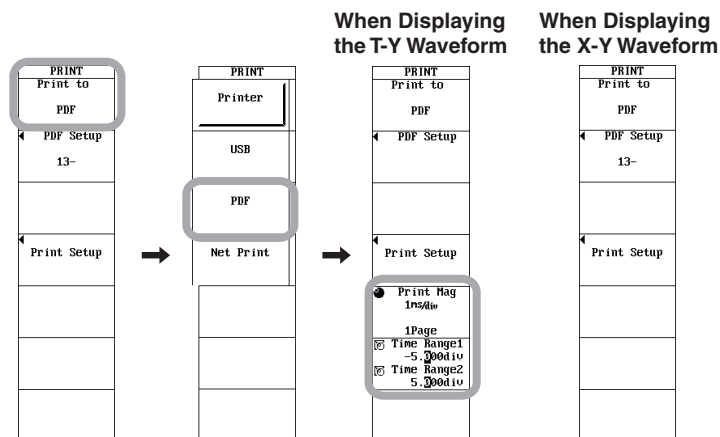
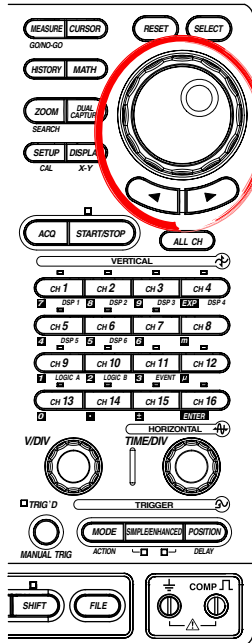

**Specifying the Print Settings**

8. Press the **Print Setup** soft key. The print setup dialog box opens.  
When displaying T-Y waveforms, proceed to step 9.  
When displaying X-Y waveforms, proceed to steps 14 to 17 and then 23.

**Setting the Print Format**

9. Use the **jog shuttle** and **SELECT** to select Format from Single (1 division) to Hexadecimal (16 divisions).

**Note**

The print format setting is linked with the DISPLAY menu > Format setting.

**Setting the Extra Area (Only When Displaying the T-Y Waveform)**

10. Use the **jog shuttle** and **SELECT** to set **Extra Area** to ON or OFF.

**Setting the Flexible Zone (Only When Displaying the T-Y Waveform)**

11. Use the **jog shuttle** and **SELECT** to select **Setup** in **Flexible Zone**.
12. Use the **jog shuttle** and **SELECT** to set Mode to OFF or ON.
13. Use the **jog shuttle** and **SELECT** to set Upper/Lower of the waveform to be recorded.

**Setting the Graticule**

• **Setting the Grid**

14. Use the **jog shuttle** and **SELECT** to set Type to , OFF, or .

• **Setting Dark/Light**

15. Use the **jog shuttle** and **SELECT** to set Dark/Light to Light or Dark.

• **Setting the Width of the Vertical Scale**

16. Use the **jog shuttle** and **SELECT** to set Width to 1div or 10mm.

**Note**

The grid setting is linked with the DISPLAY menu > Graticule setting. However, if OFF is selected, the DISPLAY menu is set to .

When Displaying the T-Y Waveform

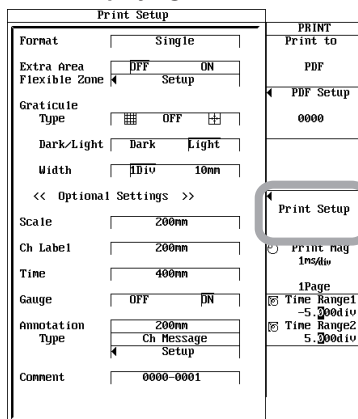

When Displaying the X-Y Waveform

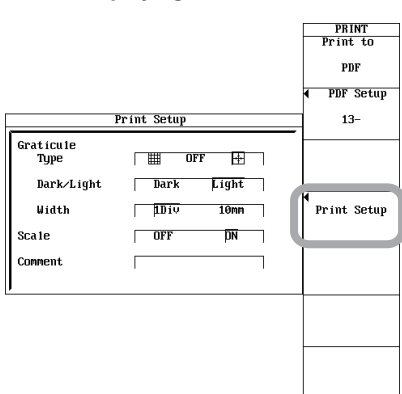

### 13.13 Creating PDF files of the printed image (DL750P only)

#### Setting Details

- **Setting the Scale Value (Only When Displaying the X-Y Waveform)**
  17. Use the **jog shuttle** and **SELECT** to set Scale to OFF or ON.
- **Setting Whether to Print the Time (Only When Displaying the T-Y Waveform)**
  18. Use the **jog shuttle** and **SELECT** to set Time to OFF, 200mm, 400mm, or 800mm.
- **Setting Whether to Print the Gauge (Only When Displaying the T-Y Waveform)**
  19. Use the **jog shuttle** and **SELECT** to set Gauge to OFF or ON.
- **Setting the Annotation (Only When Displaying the T-Y Waveform)**
  20. Use the **jog shuttle** and **SELECT** to set the print interval of annotations in the right column of Annotation to OFF, 200mm, 400mm, or 800mm.
  21. Use the **jog shuttle** and **SELECT** to set the type of annotation to be printed in the right column of Type to CH Information, CH Message, or CH Data.  
If CH Message is selected, proceed to step 22.  
If CH Information or CH Data is selected, proceed to step 23.
  22. Use the **jog shuttle** and **SELECT** to select Setup. Then, enter the message you wish to print for the channel using up to 80 characters according to the procedure in section 4.2.
- **Setting Comments**
  23. Use the **jog shuttle** and **SELECT** to select Comment. Then, enter the comment text you wish to print using up to 20 characters according to the procedure in section 4.2.

#### Note

- The comment setting is linked with the PRINT menu > Comment setting.
- When creating a PDF file of the print image while displaying T-Y waveforms, Scale and Ch Label settings are void.

When Displaying the T-Y Waveform

Print Setup	
Format	Single
Extra Area	OFF ON
Flexible Zone	Setup
Graticule	
Type	OFF ON
Dark/Light	Dark Light
Width	1Div 10mm
<< Optional Settings >>	
Scale	200mm
Ch Label	200mm
Time	400mm
Gauge	OFF ON
Annotation	200mm
Type	Ch Message Setup
Comment	0000-0001

When Displaying the X-Y Waveform

Print Setup	
Graticule	
Type	OFF ON
Dark/Light	Dark Light
Width	1Div 10mm
Scale	OFF ON
Comment	

**Setting the PDF File**

24. Press the **PDF Setup** soft key to display the PDF setup dialog box.

**Setting the Paper Size**

25. Use the **jog shuttle** and **SELECT** to set Paper Size to Built-in Printer, A3, A4, or A5.

**Setting the Orientation (If A3, A4, or A5 was selected in step 25 (Only When Displaying the T-Y Waveform))**

26. Use the **jog shuttle** and **SELECT** to set Orientation to Landscape or Portrait.

**Setting the Number of Divisions per Page (If A3, A4, or A5 was selected in step 25)**

27. Use the **jog shuttle** and **SELECT** to set Div/Page.

**Setting Document Information**

28. Use the **jog shuttle** and **SELECT** to select Title, Author, Sub Title, or KeyWord. Enter the title, author, sub title of the PDF file using up to 30 characters and the keyword using up to 90 characters according to the procedure given in section 4.2.

**Setting the Color**

29. Use the **jog shuttle** and **SELECT** to set Color to OFF or ON.

**Enabling/Disabling Compression**

30. Use the **jog shuttle** and **SELECT** to set Compression to ON or OFF.

**Setting Auto Naming**

31. Use the **jog shuttle** and **SELECT** to select Auto Naming from OFF, Numbering, and Date.

**Setting the PDF File Name**

32. Use the **jog shuttle** and **SELECT** to select File Name. Then, enter the file name using up to 16 characters according to the procedure in section 4.2.

**Selecting the Save Destination of the PDF File**

33. Use the **jog shuttle** and **SELECT** to select File List. Then, select the file save destination according to steps 14 to 17 in section 13.7.



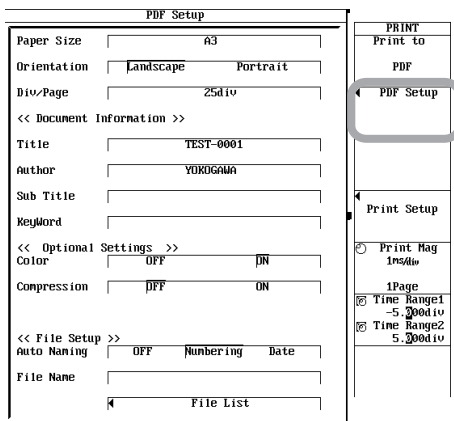

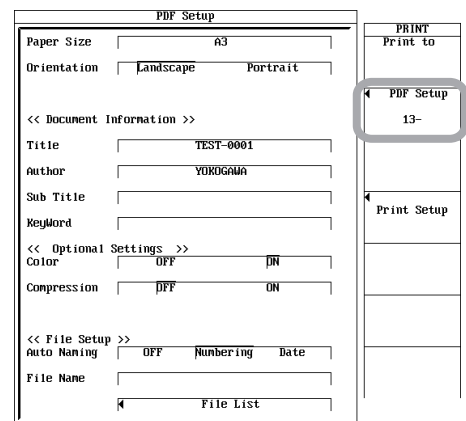

When Displaying the T-Y Waveform



When Displaying the X-Y Waveform



### **Executing the PDF File Generation**

34. Press **PRINT**. A PDF file is created using the conditions set in steps 4 to 33. Pressing **PRINT** again aborts the save operation. While the data is being saved, an icon corresponding the save destination medium ( FD,  Zip disk,  PC card,  external SCSI device,  internal HD, or  USB storage device) is displayed in the upper left corner of the screen.

### **Explanation**

#### **Print to**

When creating a PDF file of the print image (image similar to the printed output of fine print), set the print destination to PDF.

#### **Selecting the Section to Be Output to the PDF File: Time Range1/Time Range2**

Can be specified only when displaying T-Y waveforms. Set the output start point and output end point of the section to be output to the PDF file.

#### **Print Magnification: Print Mag**

Can be specified only when displaying T-Y waveforms. Set the waveform magnification for creating the PDF file. The top section of the menu shows the magnification; the bottom section shows the number of pages when the PDF file is created using the magnification indicated in the top section.

#### **Print Setup**

##### **Format, Extra Area, Flexible Zone, and Graticule (Scale)**

The items other than graticule can be specified only when displaying T-Y waveforms. The format, extra area, flexible zone, and graticule (scale) settings are the same as the settings when performing fine print or zoom print on the built-in printer. For details, see page 12-10.

##### **Details**

- **Time Print/Gauge Print**

Can be specified only when displaying T-Y waveforms. The time print and gauge print settings are the same as the settings when performing fine print or zoom print on the built-in printer. For details, see page 12-11.

The scale value and channel label are not printed when creating a PDF file.

- **Annotation**

Can be specified only when displaying T-Y waveforms. The annotation setting is the same as the setting when performing fine print or zoom print on the built-in printer. For details, see page 12-11. When creating a PDF file, annotations are not printed if the print interval is set to OFF. However, if the print interval is set to value other than OFF, annotations are printed on each page of the PDF file.

- **Scale**

Can be specified only when displaying X-Y waveforms. Select whether to print the scale.

- **Comment**

The comment setting is the same as the setting when performing fine print or zoom print on the built-in printer. For details, see page 12-11.



**Setting the PDF File**

**Paper Size**

Select the paper size from built-in printer size, A3, A4, and A5. If the built-in printer size is selected, a PDF file is created of an image similar to the printed output on the built-in printer (A4 size).

**Orientation**

If the paper size is set to A3, A4, or A5, set the orientation of the PDF file to Landscape or Portrait.

**Number of Divisions per Page: Div/Page**

Can be specified only when displaying T-Y waveforms. If the paper size is set to A3, A4, or A5, set the number of divisions to be printed per page in the PDF file. The specified number of divisions is printed per page in the PDF file. The selectable range varies depending on the paper size, orientation, and gauge (see the previous page) as follows:

Paper Size	Orientation	Selectable Range of Div/Page	
		Gauge: OFF	Gauge: ON
Built-In Printer	-	20 (fixed)	20 (fixed)
A3	Portrait	1 to 25	1 to 20
A3	Landscape	1 to 40	1 to 35
A4	Portrait	1 to 20	1 to 15
A4	Landscape	1 to 25	1 to 20
A5	Portrait	1 to 10	1 to 10
A5	Landscape	1 to 20	1 to 15

**Document Information: Title, Author, Sub Title, and KeyWord**

As necessary, enter the title, author, sub title, and keyword of the PDF file to be created.

**Color**

The PDF file is created in color if ON is selected and monochrome if OFF is selected.

**Compression**

Select whether to compress the file. If ON is selected, the file is compressed. However, the generation of the PDF file takes longer than when OFF is selected.

**File Setup**

Set the auto naming, file name, and file output destination of the PDF file. These settings are the same as those of normal files. For details, see section 13.7.

**Executing the PDF File Generation**

The PDF file is created using the specified conditions. The extension to the PDF file is .pdf.

**Note**

- A PDF file of a print image can be created even when all waveform display (Display Mode: All) is selected in the history memory function.
- A PDF file whose size exceeds 2GB cannot be created. Adjust the number of channels, pages, and history memory pages (see section 11.1), so that only the required sections are saved to the PDF file.

13.13 Creating PDF files of the printed image (DL750P only)

**PDF File Example**

When Displaying the T-Y Waveform (Paper Size: A4)

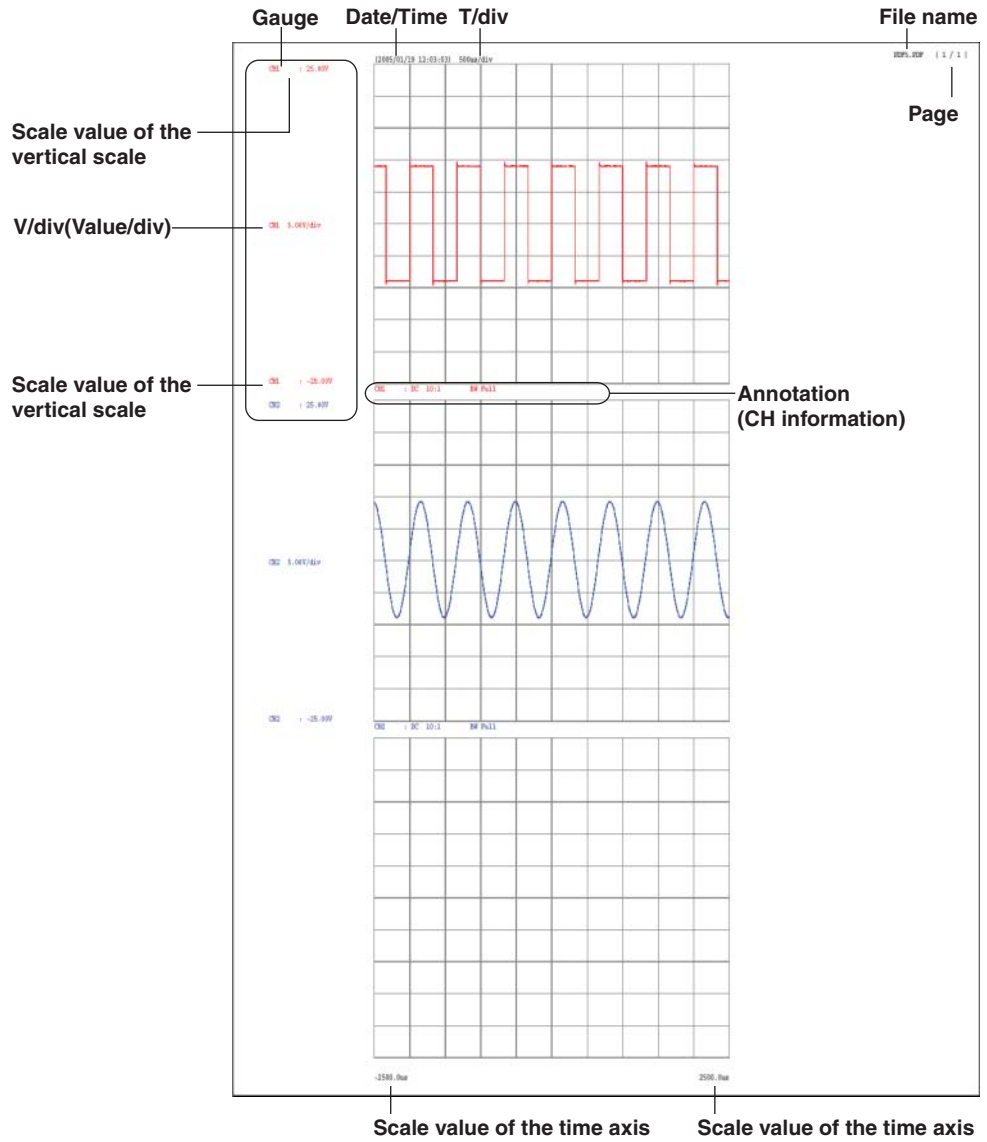

When Displaying the X-Y Waveform (Paper Size: A5)

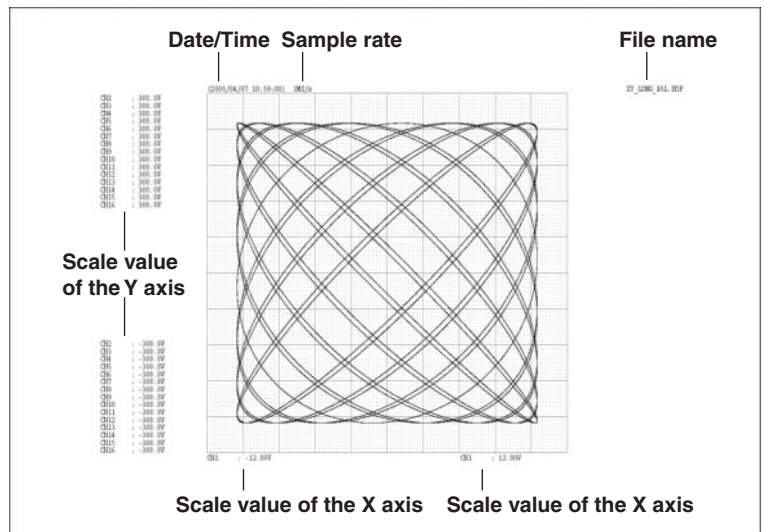

# 13.14 Loading/Converting Realtime Recorded Waveforms

<For a description of this function, refer to page 2-35.>

## Procedure

### Loading the Realtime Recorded Waveform Data

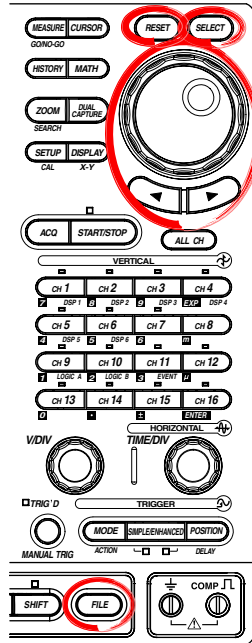

1. Press **FILE**.
2. Press the **File Item** soft key. The File Item setup menu appears.
3. Press the **Waveform** soft key.

### Selecting the Data Type

4. Press the **Data Type** soft key. The data type selection menu appears.
5. Press the **Real Time** soft key.

### Selecting the Load Source Medium/Directory

6. Press the **Load** soft key. The load setup menu and File List window appear.
7. Select the load source directory according to steps 13 to 18 in "Saving the Waveform Data" in section 13.7.

### Note

The files that have been realtime recorded are saved in the [RealTime] drive. WDF data that is copied from the [RealTime] drive to another drive can also be loaded.

### Selecting the File to Be Loaded

8. Turn the **jog shuttle** to select the file.

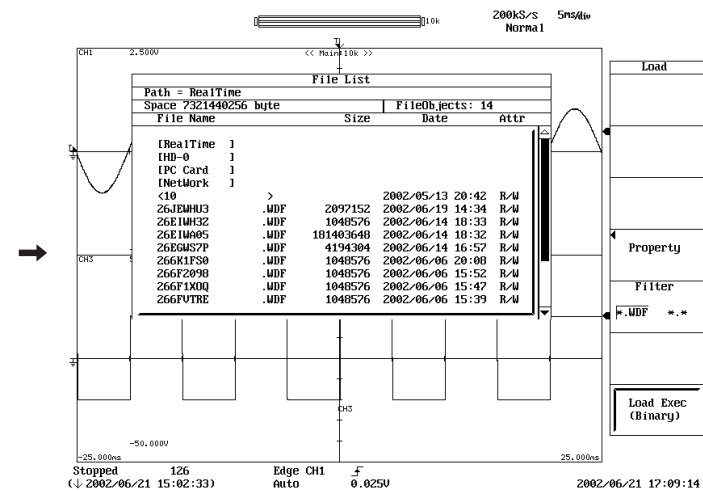
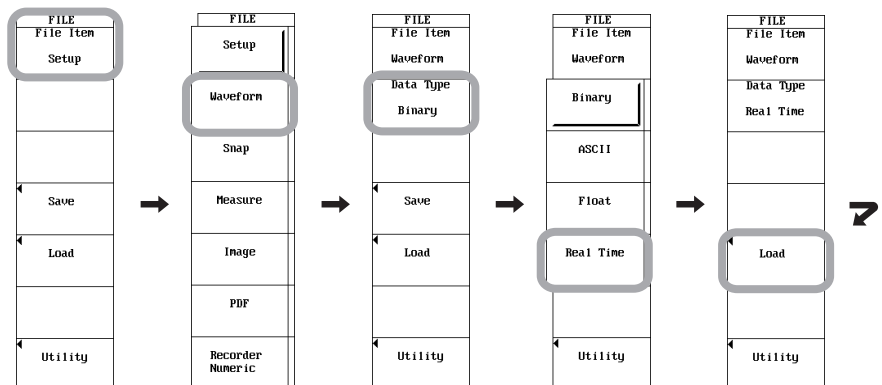

## 13.14 Loading/Converting Realtime Recorded Waveforms

### Executing the Load Operation

9. Press the **Load Exec** soft key. A dialog box appears showing the module information of the selected realtime recorded waveform data and the current module information of the DL750/DL750P.
10. Press the **Load Exec** soft key again. The selected file is read from the directory indicated in Path=..... At the same time, the **Load Exec** soft key changes to an **Abort** soft key.

### Note

If the module information of the realtime recorded waveform data and the current module information of the DL750/DL750P differ, the realtime recorded waveform data cannot be loaded.

### Aborting the Load Operation

11. Press the **Abort** soft key. The load operation is aborted. At the same time, the **Abort** soft key changes to a **Load Exec** soft key.

### Specifying the Files to Be Displayed in the File List Window and Displaying Properties

12. Carry out steps 27 to 29 in “Saving the Waveform Data” in section 13.7.

### Note

Files with .WDF extension in the RealTime area and User area of the internal hard disk (optional) can be loaded.

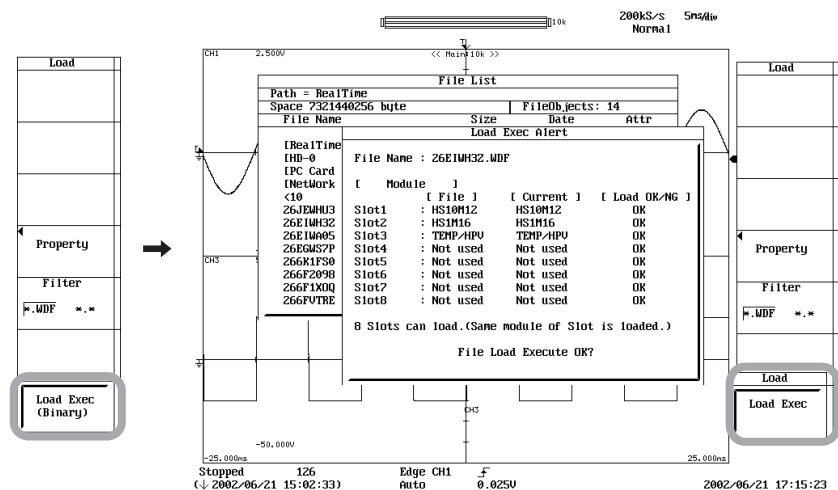

## Converting the Realtime Recorded Waveform Data to Binary, ASCII, or Float Format and Saving

1. Load the realtime recorded waveform data according to the procedure described in “Loading the Realtime Recorded Waveform Data.”
2. Convert the realtime recorded waveform data to Binary, ASCII, or Float format and save the data according to the procedure described in “Saving the Waveform Data” in section 13.7.

### Note

Files containing realtime recorded waveform data that has been converted into Binary cannot be loaded into the DL750/DL750P.

**Explanation****Selecting the Data Type****Real Time**

- Data saved using realtime recording.
- The data that is realtime recorded can be loaded to display the waveform and compute numeric data.
- The extension is .WDF.

**Data Size**

The maximum data size is as follows: The unit of the record length is word.  
(Record length  $\times$  2  $\times$  (the number of channels + 1)  $\times$  (1.05 to 1.15)) bytes

**[RealTime] Drive**

- The WDF data that is created by the realtime recording is saved to the [RealTime] drive.
- The [RealTime] drive appears only when Data Type is set to Real Time. If you wish to manage the files on the [RealTime] drive, set Data Type to Real Time.
- You can set the size of the RealTime drive in the range of 30% to 70% of the entire capacity of the internal hard disk. This setting is entered when the internal hard disk is formatted. For details, see section 13.5.

# 13.15 Changing the File Attributes and Deleting Files

## CAUTION

Never remove the storage medium (disk) or turn OFF the power while the access indicator or the floppy disk, Zip disk, or internal hard disk (optional) icon is blinking. Such acts can damage the storage medium or destroy the data on the medium.

### Procedure

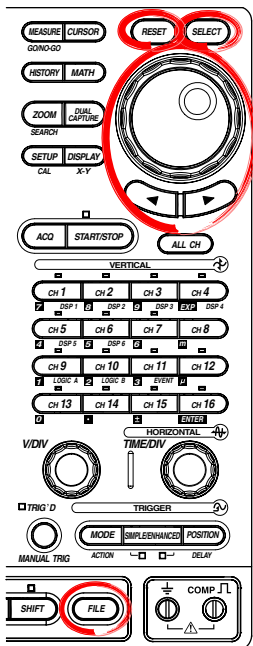

1. Press **FILE**.
2. Press the **Utility** soft key. The Utility setup menu and the File List window appear.

### Selecting Media and Directories

3. Select the medium and directory according to steps 4 to 9 in section 13.8, "Saving/Loading the Setup Data."

### Changing the File Attributes

4. Press the **Function** soft key. The file function selection menu is displayed.
5. Press the **Delete** soft key.
6. Turn the **jog shuttle** to select the file.
7. Press the **Attr** soft key. The attribute of the selected file changes.

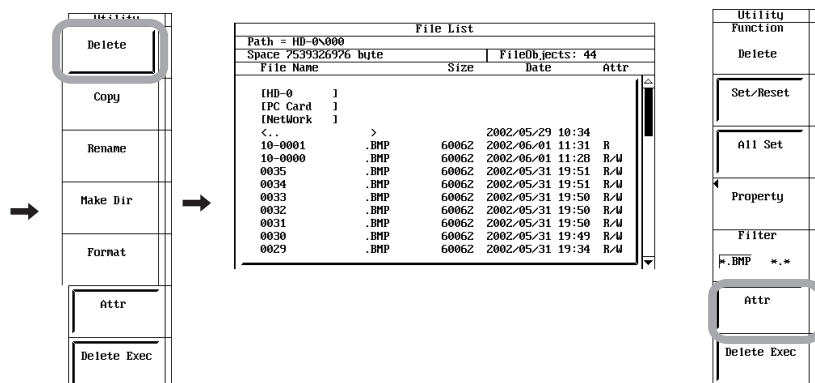
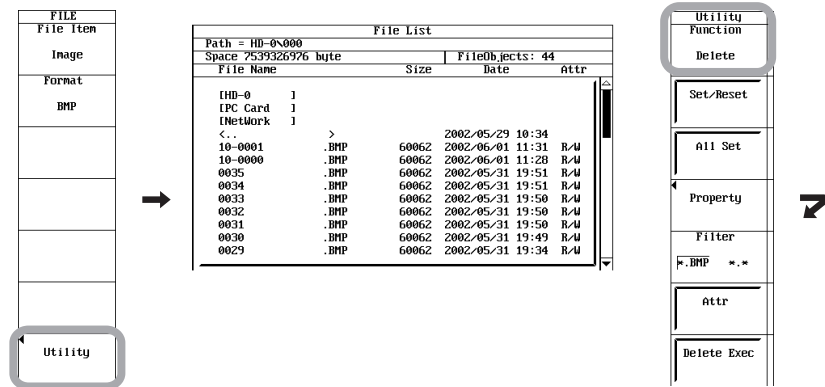

**Selecting the File to Be Deleted One at a Time**

8. Turn the **jog shuttle** to select the file.
9. Press the **Set/Reset** soft key. An asterisk (\*) is displayed to the left of the selected file to indicate that it will be deleted. Pressing the **Set/Reset** soft key again removes the asterisk (\*) to the left of the selected file. The file will not be deleted.

Proceed to step 13.

**Selecting the Files to Be Deleted at Once**

10. Turn the **jog shuttle** to select the file, directory, or medium.
11. Press the **All set** soft key. Asterisks (\*) are displayed to the left of every file in the directory containing the selected file or directory to indicate that they will be deleted. At the same time, the **All Set** soft key changes to an **All Reset** soft key.
12. Press the **All Reset** soft key. Asterisks (\*) are removed from the left of every file in the directory containing the selected file or directory to indicate that they will not be deleted. At the same time, the **All Reset** soft key changes to an **All Set** soft key.

**Executing the Delete Operation**

13. Press the **Delete Exec** soft key. All files with asterisk marks are deleted.

**Specifying the Files to Be Displayed in the File List Window and Displaying Properties**

14. Carry out steps 19 to 21 in section 13.8, "Saving/Loading the Setup Data."

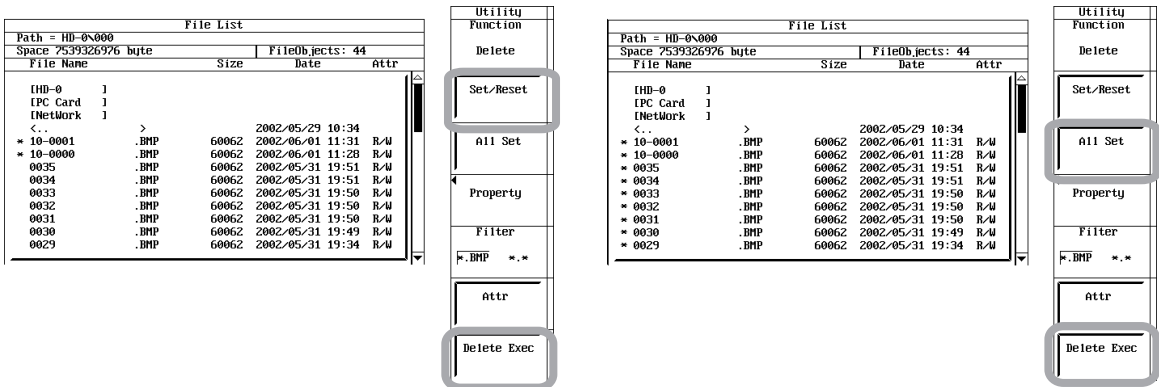

### **Explanation**

#### **Selecting the Storage Medium and Directory: File List**

Media on which saving and loading are possible are displayed on the File List window.

- **Display Example of Storage Media**

- [FD]: Floppy disk
- [ZIP]: Zip disk
- [PC Card]: PC card
- [HD]: Hard disk
- [SCSI5]: SCSI device with the ID number set to 5<sup>1</sup>
- [SCSI5-1]: Partition 1 of a SCSI device whose ID number is 5<sup>1</sup>
- [NetWork]: Network drive (when the Ethernet interface option is installed)
- [USB]: USB storage device

1. When a SCSI device whose ID number is 5 is connected

#### **Selecting the File Attribute: Attr (excluding Net Drive)**

Select the file attribute of each file from the following list of choices.

- **R/W**  
Read and write possible.
- **R**  
Read only. Cannot write to the file or delete the file.

#### **Selecting the Files to Be Deleted**

You can delete all files that have an asterisk to the left of the file name. There are two methods in selecting the files to be deleted.

- **Selecting the Files One at a Time: Set/Reset**  
Place an asterisk to the left of the file names one at a time, using the Set/Reset soft key.
- **Selecting All the Files at Once: All Set**  
Places an asterisk to the left of all the file names selected collectively using the All Set soft key.  
Selecting a file or directory and pressing the All Set soft key places an asterisk on every file in the directory containing the selected file or directory.

#### **Specifying the File to Be Displayed on the File List Window: Filter**

Specify the type of files to be displayed.

- **\*.Extension**  
Displays only the data file that was selected in the File Item setup menu and the data type menu.
- **\*.\***  
Displays all the files in the medium.



### **Property**

Displays the following information about the selected file: filename.extension, the file size, the date the file was saved, the attribute, etc.

### **Note**

---

- Files cannot be deleted while the data acquisition is in progress.
  - Data that is deleted cannot be recovered. Make sure you erase the correct files.
  - You can not delete directories if there are files in them.
  - If an error occurs while deleting multiple files, the files after the error occurrence are not deleted.
  - You cannot change a directory attribute.
  - This function cannot be used when using the FTP server function, network printer function, or the Web server function.
  - The screen image data and thumbnail data are saved in pairs of files. If you specify "\*" for the files to be displayed (Filter) on the File List and manipulate individual files (Delete, Rename, or Copy), the thumbnail display function can no longer be used.
  - If the realtime recorded waveform is being displayed, the file cannot be deleted.
  - If you wish to delete the files on the [RealTime] drive, set Data Type to Real Time.
-

# 13.16 Copying Files

## CAUTION

Never remove the storage medium (disk) or turn OFF the power while the access indicator or the floppy disk, Zip disk, internal hard disk (optional), or USB storage device icon is blinking. Such acts can damage the storage medium or destroy the data on the medium.

### Procedure

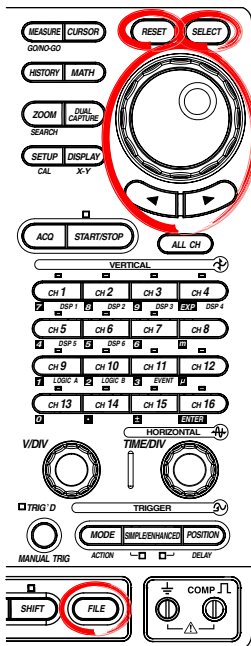

1. Press **FILE**.
2. Press the **Utility** soft key. The Utility setup menu and the File List window appear.
3. Press the **Function** soft key. The file function selection menu is displayed.
4. Press the **Copy** soft key.

### Selecting Media and Directories

5. Select the medium and directory according to steps 4 to 9 in section 13.8, "Saving/Loading the Setup Data."

### Selecting the Copy Source Files One at a Time

6. Turn the **jog shuttle** to select the file.
7. Press the **Set/Reset** soft key. An asterisk (\*) to the left of the selected file to indicate that it will be copied. Pressing the **Set/Reset** soft key again removes the asterisk (\*) to the left of the selected file. The file will not be copied. Proceed to step 11.

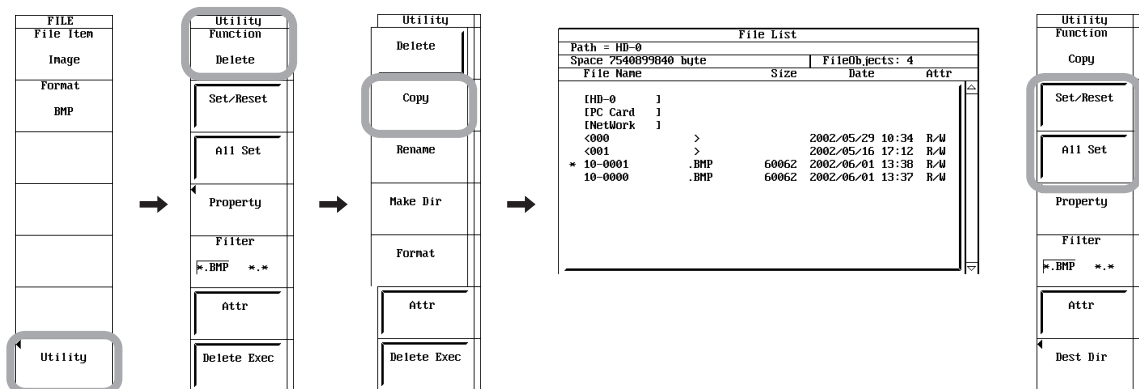

**Selecting the Copy Source Files at Once**

8. Turn the **jog shuttle** to select the file, directory, or medium.
9. Press the **All set** soft key. Asterisks (\*) are displayed to the left of every file in the directory containing the selected file or directory to indicate that they will be copied. At the same time, the **All Set** soft key changes to an **All Reset** soft key.

**Resetting the Selected Copy Source Files at Once**

10. Press the **All Reset** soft key. Asterisks (\*) are removed from the left of every file in the directory containing the selected file or directory to indicate that they will not be copied. At the same time, the **All Reset** soft key changes to an **All Set** soft key.

**Selecting the Copy Destination**

11. Press the **Dest Dir** soft key. The copy execution menu and the copy destination File List window appears.

**Selecting Copy Destination Medium and Directory**

12. Select the copy destination medium and directory according to steps 4 to 9 in section 13.8, "Saving/Loading the Setup Data."

**Executing the Copy Operation**

13. Press the **Copy Exec** soft key. All the copy source files with asterisk marks are copied.

**Specifying the File to Be Displayed in the File List Window and Viewing File Properties**

14. Carry out steps 19 to 21 in section 13.8, "Saving/Loading the Setup Data."

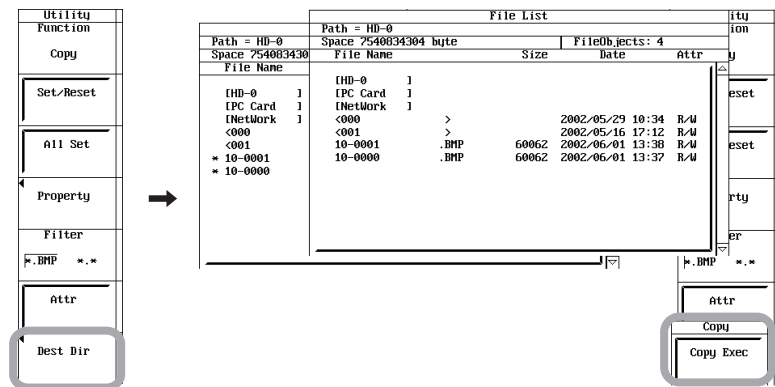

### **Explanation**

#### **Selecting the Copy Source Files**

You can copy all files that have an asterisk to the left of the file name. There are two methods in selecting the files to be copied.

- **Selecting the Files One at a Time: Set/Reset**

Place an asterisk to the left of the file names one at a time, using the Set/Reset soft key.

- **Selecting All the Files at Once: All Set**

Places an asterisk to the left of all the file names selected collectively using the All Set soft key.

If you select a file and press the All Set soft key, asterisk marks are placed on all the files in the directory containing the selected file.

#### **Specifying the File to Be Displayed on the File List Window: Filter**

Specify the type of files to be displayed.

- **\*.Extension**

Displays only the data file that was selected in the File Item setup menu and the data type menu.

- **\*\***

Displays all the files in the medium.

#### **Property**

Displays the following information about the selected file: filename.extension, the file size, the date the file was saved, the attribute, the comment, etc.

#### **Note**

---

- Files cannot be copied while the data acquisition is in progress.
  - If an error occurs while copying multiple files, the files after the error occurrence are not copied.
  - You cannot change a directory attribute.
  - You cannot copy files if files with the same file name exist at the copy destination.
  - You cannot copy the same files to another directory after copying the files. Select the files to be copied again and copy them.
  - The date/time information of the copied file retains the date/time information of the copy source file. However, if the copy destination is a network drive, the date/time is set to the date/time when the file is copied.
  - This function cannot be used when using the FTP server function, network printer function, or the Web server function.
  - The screen image data and thumbnail data are saved in pairs of files. If you specify “\*.\*\*” for the files to be displayed (Filter) on the File List and manipulate individual files (Delete, Rename, or Copy), the thumbnail display function can no longer be used.
  - Copying to the [RealTime] drive is not possible. (Copying from the [RealTime] drive to other drives is possible.)
-

# 13.17 Changing the Directory/File Name of the Storage Medium and Creating Directories

## CAUTION

Never remove the storage medium (disk) or turn OFF the power while the access indicator or the floppy disk, Zip disk, internal hard disk (optional), USB storage device icon is blinking. Such acts can damage the storage medium or destroy the data on the medium.

### Procedure

#### Changing the Directory/File Name of the Storage Medium

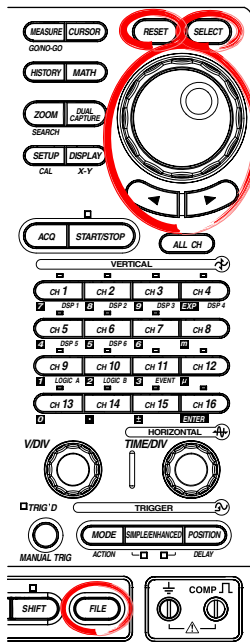

1. Press **FILE**.
2. Press the **Utility** soft key. The Utility setup menu and the File List window appear.
3. Press the **Function** soft key. The file function selection menu is displayed.
4. Press the **Rename** soft key.

#### Selecting Media and Directories

5. Select the medium and directory according to steps 4 to 9 in section 13.8, "Saving/Loading the Setup Data."

#### Changing the File Attributes

6. Change the file attribute according to steps 6 and 7 in section 13.15, "Changing the File Attributes and Deleting Files."

#### Changing the Directory/File Name of the Storage Medium (Excluding Net Drive)

7. Turn the **jog shuttle** to select a directory name or file name.
8. Press the **File Name** soft key. A keyboard appears. The name of directory/file is displayed in the entry box of the keyboard.
9. Enter the directory name or file name according to the procedure given in section 4.2.

#### Specifying the Files to Be Displayed in the File List Window and Displaying Properties

10. Carry out steps 19 to 21 in section 13.8, "Saving/Loading the Setup Data."

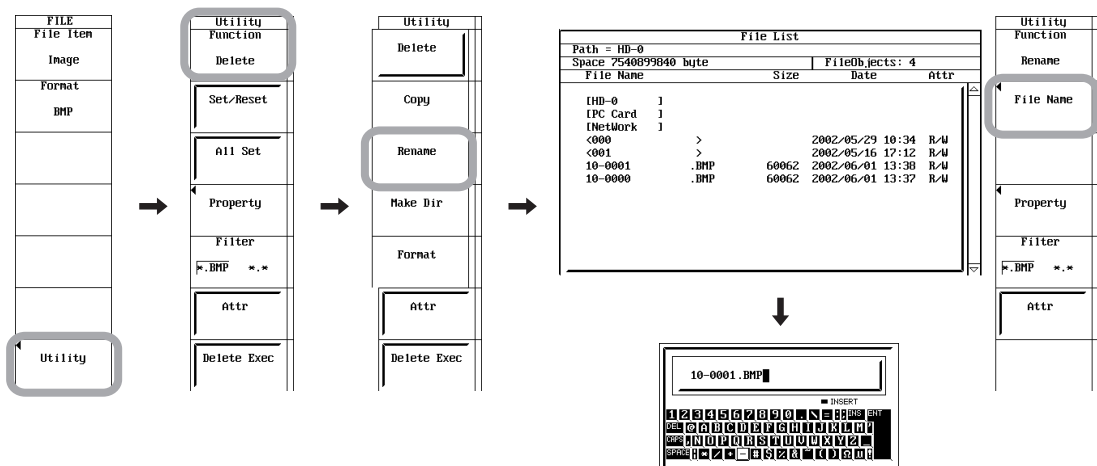

### Creating a Directory

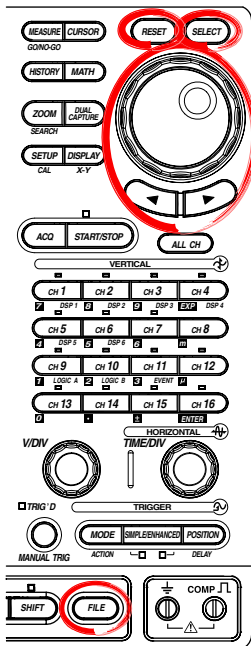

1. Press **FILE**.
2. Press the **Utility** soft key. The Utility setup menu and the File List window appear.
3. Press the **Function** soft key. The file function selection menu is displayed.
4. Press the **Make Dir** soft key.

#### Selecting Media and Directories

5. Select the medium and directory according to steps 4 to 9 in section 13.8, "Saving/Loading the Setup Data."

#### Creating Directories

6. Turn the **jog shuttle** to select a medium or directory.
7. Press the **Dir Name** soft key. A keyboard appears.
8. Enter the directory name or file name according to the procedure given in section 4.2.

#### Specifying the Files to Be Displayed in the File List Window and Displaying Properties

9. Carry out steps 19 to 21 in section 13.8, "Saving/Loading the Setup Data."

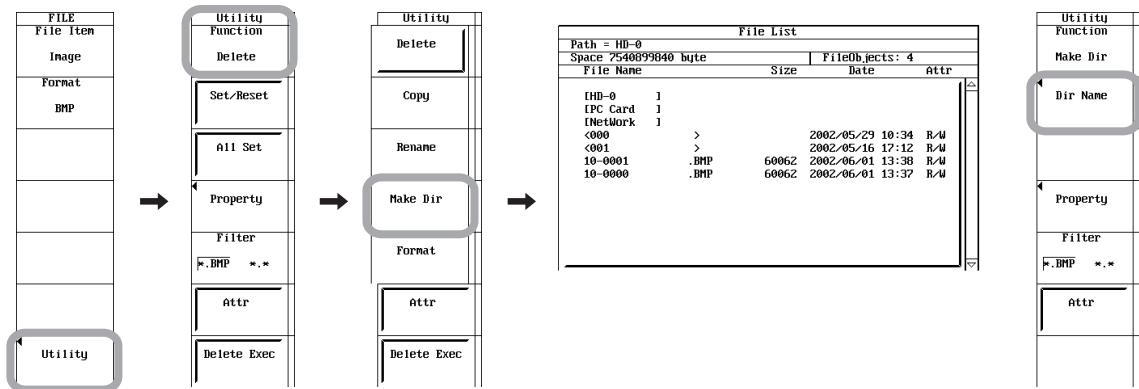

**Explanation****Selecting the Storage Medium and Directory: File List**

Media on which saving and loading are possible are displayed on the File List window.

- **Display Examples of Storage Media**

- [FD]: Floppy disk
- [ZIP]: Zip disk
- [PC Card]: PC card
- [HD]: Hard disk
- [SCSI5]: SCSI device with the ID number set to 5<sup>1</sup>
- [SCSI5-1]: Partition 1 of a CSI device whose ID number is 5<sup>1</sup>
- [NetWork]: Network drive when the Ethernet interface option is installed)
- [USB]: USB storage device

1. When a SCSI device whose ID number is 5 is connected

**Selecting the File Attribute: Attr (Excluding Net Drive)**

Select the file attribute of each file from the following list of choices.

- **R/W**  
Read and write possible.
- **R**  
Read only. Cannot write to the file or delete the file.

**Changing the Directory/File Name of the Storage Medium: Rename**

Number of characters and types that can be used

Item	Number of Characters	Characters That Can Be Used
Directory name	1 to 16 characters	0 to 9, A to Z, %, _, (, ), -
File name	1 to 16 characters	0 to 9, A to Z, %, _, (, ), -

\* However, a directory name that starts with "ND" (ND000 for example) is not allowed.

**Creating a Directory: Make Dir**

You can create a new directory in the medium. See above for the assignment of the directory name when creating a new directory.

**Specifying the File to Be Displayed on the File List Window: Filter**

Specify the type of files to be displayed.

- **\*.Extension**  
Displays only the data file that was selected in the File Item setup menu and the data type menu.
- **.\***  
Displays all the files in the medium.

## 13.17 Changing the Directory/File Name of the Storage Medium and Creating Directories

---

### **Property**

Displays the following information about the selected file: filename.extension, the file size, the date the file was saved, the attribute, the comment, etc.

### **Note**

---

- You cannot rename a directory/file or create a new directory while the data acquisition is in progress (START/STOP indicator is ON).
  - You cannot change a directory attribute.
  - If a file with the same name already exists in the same directory, the file cannot be renamed.
  - If a directory with the same name already exists in the same directory, the directory cannot be created.
  - This function cannot be used when using the FTP server function, network printer function, or the Web server function.
  - The screen image data and thumbnail data are saved in pairs of files. If you specify “\*.\*” for the files to be displayed (Filter) on the File List and manipulate individual files (Delete, Rename, or Copy), the thumbnail display function can no longer be used.
  - Directories cannot be created on the [RealTime] drive.
-



---

## 13.18 Connecting a PC to the DL750/DL750P via SCSI

<For a description of this function, refer to page 2-65.>

You can connect a PC to the SCSI of the DL750/DL750P and access the internal hard disk (optional) from the PC.

### Supported PC OSs

Windows 98/98 SE and Windows Me

(Connection is possible on Windows 2000, Windows XP, and Windows NT, but the updating of the files on the DL750/DL750P cannot be detected due to the limitation by the OS.)

### Items Necessary for Connection

Cable (SCSI cable: half pitch 50 pins, pin type)

Use a commercially sold cable that is 3 m or less in length that has a characteristic impedance between 90 and 132  $\Omega$ .

### Connection Procedure

#### Changing the ID Number of the DL750/DL750P

Before connecting the DL750/DL750P to a PC, you may need to change the SCSI ID of the DL750/DL750P so that it does not conflict with the PC's ID. For the procedure in changing the ID, see section 13.6.

#### Changing the ID Number of the Internal Hard Disk Drive

Set the ID number of the internal hard disk drive so that it does not overlap with the IDs of other SCSI devices. For the procedure in changing the ID, see section 13.6.



---

### CAUTION

- Make sure to follow the procedures exactly as written in "Connecting the instrument to the PC" described below. Otherwise, drives of other SCSI devices connected to the PC may get damaged.
  - Never change the contents on the DL750/DL750P disk from the PC (read only). Writing to the disk may destroy files.
  - Never perform the following operations. The internal hard disk of the DL750/DL750P will become inaccessible.
    - Delete files on the internal hard disk of the DL750/DL750P from the PC.
    - Add files to the internal hard disk of the DL750/DL750P from the PC.
  - While connected to the PC, the File List window of the DL750/DL750P may not be displayed properly.
  - If the connected PC enters sleep, standby, or rest mode, the DL750/DL750P will not be able to access the internal hard disk. Before connecting the PC to the DL750/DL750P, disable such modes on the PC.
-

### Connecting the DL750/DL750P and the PC

1. Turn OFF the DL750/DL750P and the PC.
2. Connect the DL750/DL750P and the PC with the SCSI cable.
3. Turn ON the DL750/DL750P first.
4. After the DL750/DL750P boots up completely, check that the connected SCSI device operates on the DL750/DL750P.
5. Turn ON the PC.

When connected to a PC running Windows Me

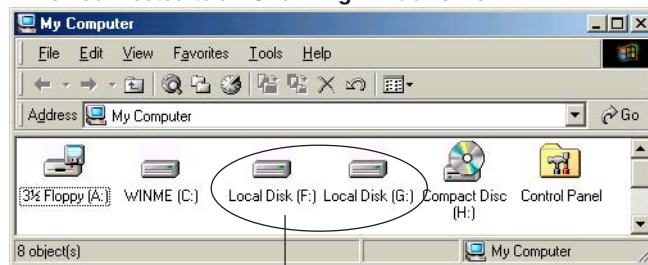

DL750/DL750P

### Precautions to Be Taken When Connecting

#### • Drive

If you format the internal hard disk using the DL750/DL750P, it is formatted into two or three partitions. For example, the PC recognizes these drives as F: and G:. The drive with the smaller drive letter (drive F: in the above example) is the area dedicated to the realtime recording. Other drives are used to store setup data, waveform data, screen image data, etc.

**The drive for realtime recording is used as a working area for the realtime recording within the DL750/DL750P. Never delete files, copy and paste files, and add new files on this drive from the PC. Otherwise, the realtime recording may not operate properly.**

Other drives are used to save other types of data such as waveforms that can be recalled later. The waveforms that can be used on the PC are saved on this drive.

#### • Newly Created File During Connection

If a file is created with the DL750/DL750P while it is connected to the PC, the new file is not recognized by the PC.

If the PC is running Windows 98/98 SE/Me, the following procedures allow the files to be recognized.

1. On Windows 98/98 SE/Me, open the "Settings" tab in the properties dialog box for the connected drive, and check the Removable<sup>1</sup> box.
  2. Reboot the PC.
  3. After creating a new file on the DL750/DL750P, select "Refresh" in the file list window (Explorer, for example).
1. Select "My Computer > Control Panel > System > Device Manager > Disk Drive" and select the relevant drive from the drive list. The "Removable" check box is located in the "Properties" dialog box under the "Settings" tab. You can check the drive number under "Current Drive." Windows 2000/XP does not have this function.

#### • Refreshing Files (Windows 98, 98 SE, and Me)

If a file is updated on the DL750/DL750P, the update will be recognized by selecting "Refresh" in the file list window of the PC (Explorer, for example).

- **Drive Letter**

If the PC to which the DL750/DL750P is connected has multiple hard disks or if the hard disk is partitioned, connecting the DL750/DL750P will cause the internal hard disk of the DL750/DL750P to be assigned drive letters after the hard disks on the PC. For details, see the instruction manual for the PC or the drive.

The drive letter for the DL750/DL750P cannot be changed.

Example

- The PC uses one hard disk as a single drive
 

Before connection	C: (HDD)
After connection	C: (HDD)
	D: (DL750/DL750P)
- The PC uses one hard disk as two drives
 

Before connection	C: (HDD)
	D: (HDD)
After connection	C: (HDD)
	D: (HDD)
	E: (DL750/DL750P)

Actually, this may vary depending on how the hard disk is partitioned and the type of interface (IDE, SCSI, etc) and drive.

**Note**

- The internal hard disk of the DL750/DL750P has a built-in terminator. When the DL750/DL750P is connected to a PC, it is recommended that the DL750/DL750P be connected to the end of the SCSI chain.
- Note that the driver letter assignments are different from the DL708, DL708E, and DL716.
- Do not access the internal hard disk of the DL750/DL750P from the PC when the internal hard disk is being accessed from the DL750/DL750P. Likewise, do not access the internal hard disk from the DL750/DL750P when the internal hard disk is being accessed from the PC.

# 13.19 Using the Voice Comment Function

<For a description of this function, refer to page 2-64.>

This section describes only the voice comment function. For details on the voice memo function, see section 7.9.

Before using the voice comment function, connect the earphone microphone with a PUSH switch to the DL750/DL750P by referring to section 3.14, "Connecting the Earphone Microphone with a PUSH Switch and Connecting the Speaker."

### Note

- The REC LEVEL and VOLUME knobs on the left side panel click in place at the center position. When using the earphone microphone with a PUSH switch, set the REC LEVEL and VOLUME knobs to the center position to obtain adequate recording level and play volume.
- If you are outputting the voice to an external speaker for the first time by using the optional speaker cable (sold separately), set the play volume to the minimum setting using the VOLUME knob.

### Procedure

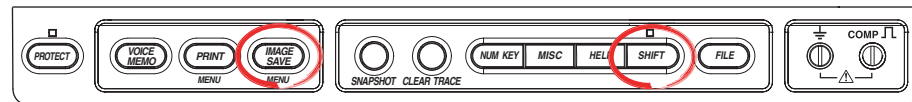

### Setting the Screen Image Data Save Operation

1. Set the screen image data save operation according to steps 1 to 16 in section 13.11.

### Recording a Voice Comment

There are two record methods.

- **Recording by Using the File Name Dialog Box**
  2. Use the **jog shuttle** and **SELECT** to press the **Rec Start** button on the File Name dialog box. Recording starts. The maximum record time is 10 s. The Rec Start display changes to Rec Stop.
  3. Press the **Rec Stop** button to stop the recording. (When 10 s elapses after starting the recording, the recording automatically stops even if the Rec Stop button is not pressed.) Proceed to step 4.
- **Recording by Using the PUSH Switch on the Earphone Microphone**
  2. Record the voice comment while holding down the PUSH switch on the earphone microphone.
  3. After recording, release the PUSH switch. Proceed to step 4.

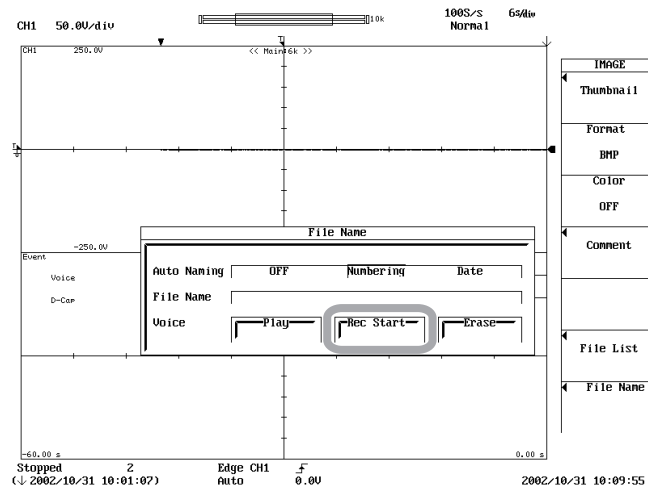
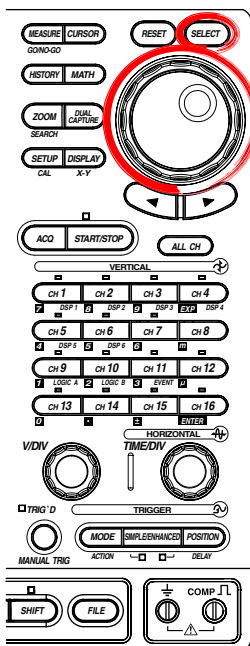

**Note**

An icon  appears at the upper left corner of the screen while voice comment recording is in progress.

**Playing a Voice Comment (Confirmation before Saving the Data)**

4. Press the **Play** button. The voice comment recorded in step 2 and 3 is played.

**Note**

- If the recorded voice comment is not needed, the voice comment can be erased using the Erase button.
- An icon  appears at the upper left corner of the screen while voice comment is being played.

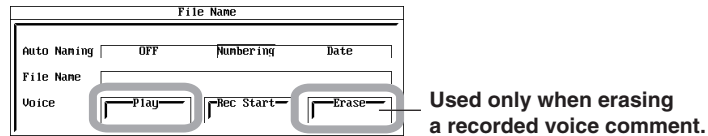

**Executing the Screen Image Data Save Operation**

5. Press **IMAGE SAVE**. The voice comment data is saved along with the screen image data to the storage medium.

**Note**

The procedure and explanation for saving the screen image data are the same as those in section 13.11. For details, see section 13.11.

**Playing of the Voice Comment**

The saved voice comment can be played from the File List window of the IMAGE and FILE menus.

6. Open the File List window according to steps 1 to 4 on page 13-42 or steps 1 to 6 on page 13-44.
7. Turn the **jog shuttle** to select the screen image data file in the File List window.
8. Press **SELECT**. The voice comment is played at the same time the thumbnail of the selected screen image data file is displayed at the lower right section of the File List window.

To clear the thumbnail, turn the **jog shuttle**.

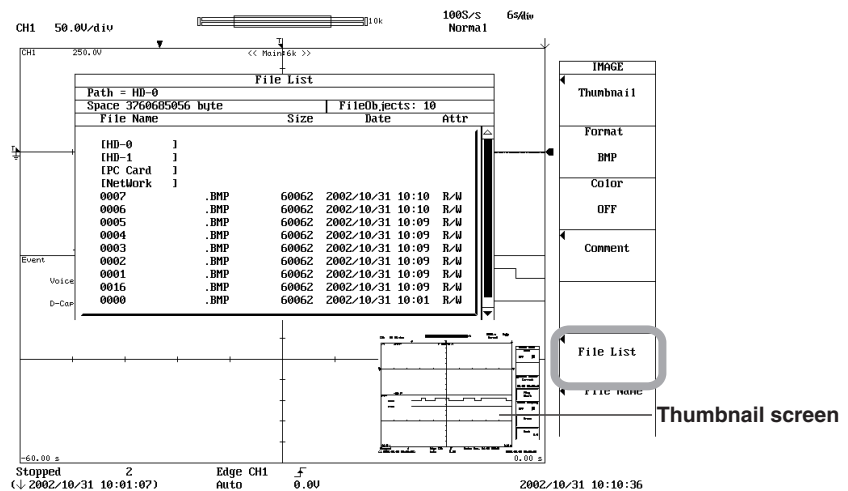

**Note**

- While voice comment is being played,  is indicated at the upper left corner of the screen.
- The procedure of opening the File List window from the Image Save or File menu is the same as that in section 13.12. For details, see section 13.12.

### ***Explanation***

A voice comment can be recorded when saving screen image data by connecting an earphone microphone with a PUSH switch to the DL750/DL750P.

#### **Record Time**

A voice comment of up to 10 s in length can be attached to a single screen image data file.

#### **Recording a Voice Comment: Rec Start/Rec Stop**

The voice comment that is saved at the time the screen image data is saved is the voice comment that was recorded immediately before the data is saved. A voice comment is saved to a single screen image data file (never to multiple files).

#### **Note**

---

The voice comment is saved as data separate from the screen image data. For a description of the extension of voice comment data file, see the explanation in section 13.11. To erase only the voice comment of the saved screen image data, erase the relevant voice comment data on the File List window of the FILE menu. (For the procedure of displaying the File List window, see steps 1 to 7 on page 13-44. For the procedure of erasing the data, see section 13.15.)

---

#### **Playing a Voice Comment (Confirmation before Saving the Data): Play**

You can play the recorded voice comment to check the contents before saving the data. If you wish to change the voice comment after playing it, record the voice comment again.

The voice comment can be overwritten any number of times until the screen image data is saved. Thus, the voice comment that is saved along with the screen image data is the voice comment that is recorded immediately before the data is saved.

#### **Erasing Voice Comments**

The recorded voice comment is erased. Use caution because voice comments that are erased cannot be recovered.

# 14.1 External Trigger Input (TRIG IN)



## CAUTION

Only input signals that meet the specifications below. Otherwise, undesirable signal such as excessive voltage may damage the DL750/DL750P.

### External Trigger Input Terminal



This terminal is used when an external signal is used as a trigger source (see section 5.6).

#### Specifications

Connector type:	RCA jack
Input Level:	TTL (0 to 5 V)
Minimum pulse width:	500 ns
Logic:	Rising edge or falling edge
Trigger delay time:	Within (200 ns + 1 sample period)
Externally synchronized operation:	Possible (by connecting TRIG IN and TRIG OUT on two DL750/DL750Ps)

### External Trigger Input Circuit Diagram and Timing Chart

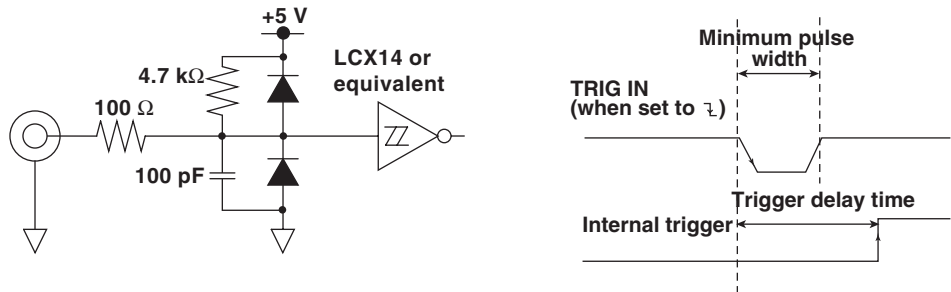

#### Note

By using the trigger output function, the operation of two DL750/DL750Ps can be synchronized.

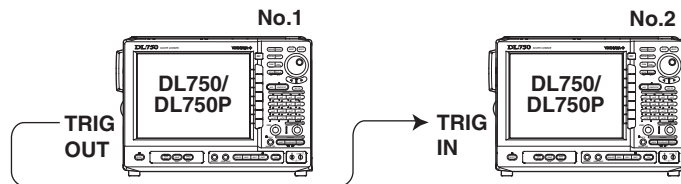

## 14.2 Trigger Output (TRIG OUT)

### External Trigger Output Terminal



A TTL level signal is output when a trigger is activated. The signal level is normally high and goes low when a trigger is activated.

#### Specifications

Connector type:	RCA jack
Output level:	CMOS level (0 to 5 V)
Logic:	Falls when the trigger is activated, rises after completing acquisition
Output delay time:	Within (1 $\mu$ s + 1 sample period)
Output hold time:	200 ns or more

### Trigger Output Circuit Diagram and Timing Chart

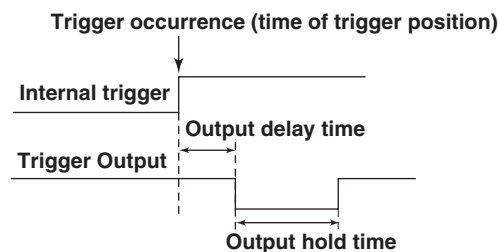
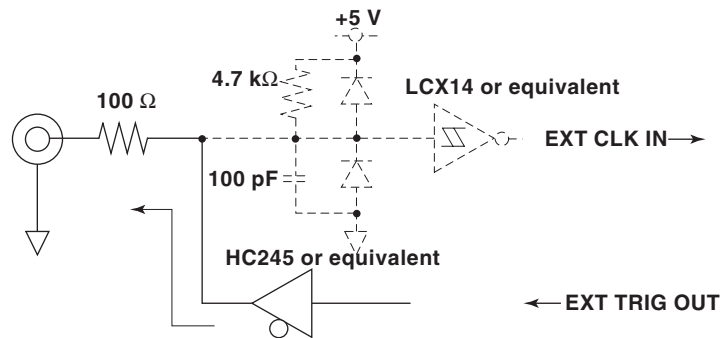

### Low Level/High Level Hold Time

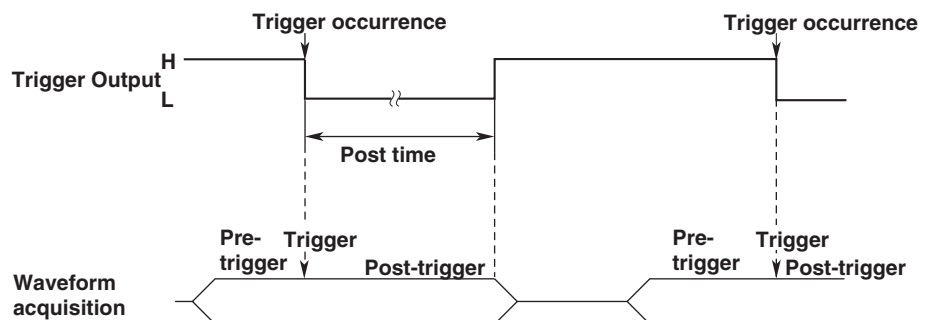



## 14.3 External Clock Input (EXT CLK IN)



### CAUTION

Only input signals that meet the specifications below. Otherwise, undesirable signal such as excessive voltage may damage the DL750/DL750P.

### External Clock Input Terminal



Use this terminal if you wish to operate the DL750/DL750P using an external clock signal.

This terminal is shared with the trigger output terminal (TRIG OUT).

### Specifications

Connector type:	RCA jack
Input Level:	TTL (0 to 5 V)
Valid edge:	Rising edge
Minimum pulse width:	400 ns or more for high and low
External clock frequency range:	1 MHz maximum.

### External Clock Input Circuit Diagram

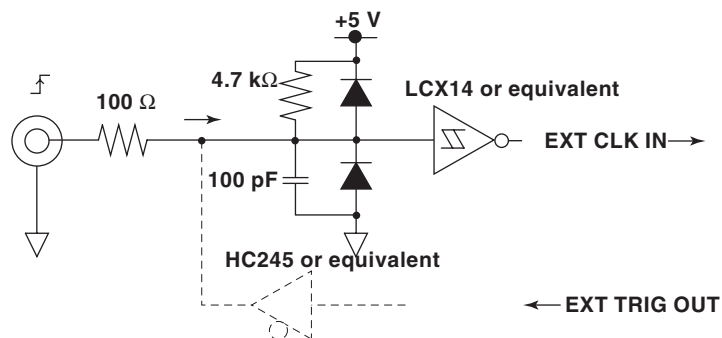

## 14.4 Video Signal Output (VIDEO OUT (SVGA))



### CAUTION

- Connect the cable after turning OFF the DL750/DL750P and the monitor.
- Do not short the VIDEO OUT terminal or apply external voltage to it. This may cause damage to the DL750/DL750P.

### Video Signal Output Terminal

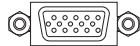

▲ VIDEO OUT (SVGA)

The DL750/DL750P display can be output to a monitor through the video signal output. Connectable monitors are multi-sync monitors capable of displaying SVGA.

### Specifications

Connector type: 15-pin D-SUB

Output type: Analog RGB output

Output resolution: SVGA output 800 × 600 dots/60 Hz Vsync

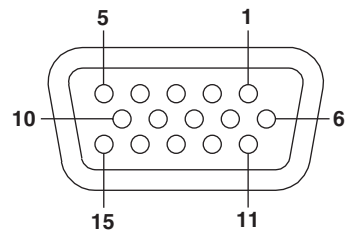

D-Sub 15-pin receptacle

Pin No.	Signal Name	Specifications
1	Red	0.7 V <sub>P-P</sub>
2	Green	0.7 V <sub>P-P</sub>
3	Blue	0.7 V <sub>P-P</sub>
4	—	
5	—	
6	GND	
7	GND	
8	GND	
9	—	
10	GND	
11	—	
12	—	
13	Horizontal sync signal	Approx. 36.4 kHz, TTL positive logic
14	Vertical sync signal	Approx. 60 Hz, TTL positive logic
15	—	

### Connecting to the Monitor



1. Turn OFF the DL750/DL750P and the monitor.
2. Connect the DL750/DL750P and the monitor using an analog RGB cable.
3. Turn ON the DL750/DL750P and the monitor.
4. Press the **MISC** soft key.
5. Press the **Next 1/2** soft key.
6. Press the **Others** soft key.
7. Press the **Video Out** soft key to select ON. The screen of the DL750/DL750P is displayed on the monitor.  
Select OFF to stop the display on the monitor.

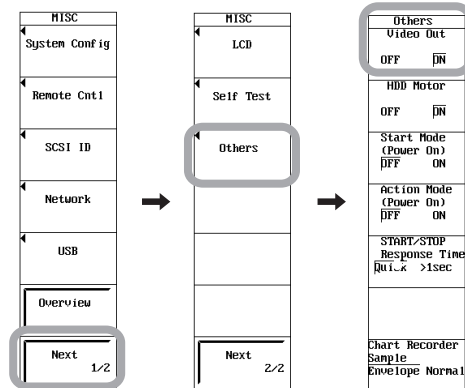

# 14.5 External Start/Stop Input (GO/NO-GO)

The DL750/DL750P start/stop can be controlled externally.

## External Start/Stop Input Terminal

The terminal is shared with the GO/NO-GO I/O Terminal. This terminal is used as an external start/stop input when the GO/NO-GO determination I/O function is not used (when Mode is OFF on the GO/NO-GO menu).

### Specifications

Modular jack (RJ-11). Use the optional accessory 366973 (sold separately) for the cable.

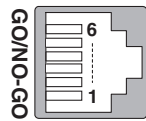

Pin No.	Signal Name
1	NC (no connection)
2	START IN
3	NC (no connection)
4	NC (no connection)
5	GND
6	SPEAKER

Connector on the DL

Input level: TTL (0 to 5 V)

## External Start/Stop Input Circuit Diagram

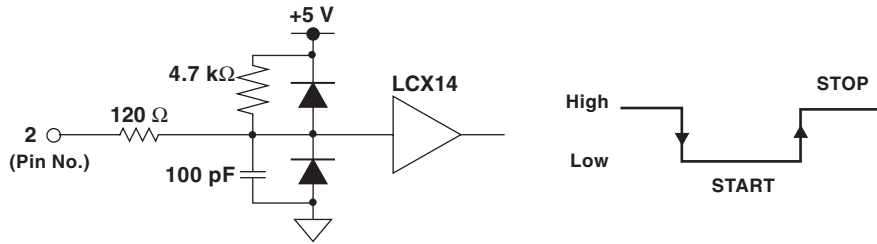

• Switch input is possible

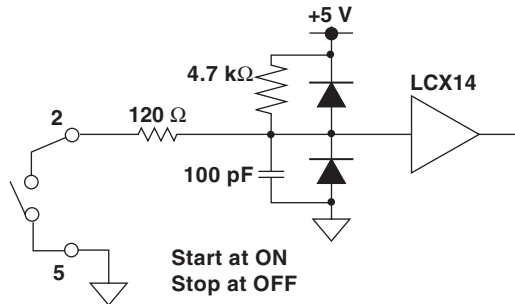

### Note

Low and High edges are used to detect start/stop.

## 15.1 DSP Channels (Optional)

<For a description of this function, refer to page 2-50.>

### What DSP Channels Are

When the /G3 option is installed, 6 dedicated computation channels (DSP1 to DSP6) are added to the DL750/DL750P. These channels perform realtime computation such as addition, subtraction, multiplication, and division between channels as well as differentiation and integration using the 16 analog input channels (CH1 to CH16) as computation sources. DSP channels can also be specified as computation sources of other channels.

The functions of DSP channels are approximately the same as those of analog input channels. Computed waveforms can be displayed in realtime even during roll mode display.

### Executable Computations

- **Addition, Subtraction, Multiplication, and Division (+, −, ×, and ÷) between Channels**  
See section 15.2, “Performing Addition, Subtraction, Multiplication, and Division (DSP Channels).”
- **Digital Filters (Gauss, Sharp, IIR (Butterworth), and Moving Average)**  
See section 15.3, “Using Filters (DSP Channels).”
- **Differentiation and Integration**  
See section 15.4, “Performing Differentiation and Integration (DSP Channels).”
- **Addition, Subtraction, Multiplication, and Division (+, −, ×, and ÷) with Coefficients between Channels**  
See section 15.5, “Performing Addition, Subtraction, Multiplication, and Division with Coefficients (DSP Channels).”

### Comparison with Analog Input Channels (CH1 to CH16)

- The allocation of the acquisition memory of DSP channels is the same as analog input channels.
- Like analog input channels, DSP channels can be used in all acquisition modes.
- Can be used as a trigger source of simple triggers (edge trigger, see section 6.5) and the OR trigger/window trigger of enhanced triggers. It cannot be set as a trigger source of other enhanced triggers.
- Computed waveform can be displayed in realtime even during roll mode display (see page 2-4).
- Can be used as a target waveform for cursor measurement (see section 11.5).
- Can be used as a target waveform of automated measurement of waveform parameters (see section 11.6).
- Can be used as a target channel for the dual capture function (see section 7.6).

### Notes Concerning DSP Channels

#### Notes When Using the DSP Channels as Computation Sources

- The maximum computation rate is 100 kS/s. If this rate is exceeded, the data is automatically re-sampled at 100 kS/s.
- The computed result is displayed in 16 bits (fixed decimal point). (Computation is performed using 32-bit floating-point decimal values, but the value is normalized to 16 bits after computation and saved to the acquisition memory.)
- All modules are computation sources.
- Analog channels (CH1 to CH16) are specified as computation sources. The computed result of a DSP channel can also be specified as a computation source of another DSP channel. However, only DSP channels with a channel number smaller than itself can be specified.

#### Notes Concerning Display

- **Value/Div Setting**

The unit of the computed result of DSP channels is expressed as “Value/Div,” because the result may not necessary be a voltage depending on the selected computing equation.

Value/Div: 123 Value/Div different settings can be specified using the V/DIV knob (1-2-5 steps).

10.00E-21 [Value/Div] to 500.0E+18 [Value/Div]

- **Variable Setting**

- **When variable is set to OFF (zooming in or out by setting the zoom rate)**

Zoom rate: The following zoom rates are available.

×0.1, ×0.111, ×0.125, ×0.143, ×0.167, ×0.2, ×0.25, ×0.33, ×0.4, ×0.5, ×0.556, ×0.625, ×0.667, ×0.714, ×0.8, ×0.833, ×1, ×1.11, ×1.25, ×1.33, ×1.43, ×1.67, ×2, ×2.22, ×2.5, ×3.33, ×4, ×5, ×6.67, ×8, ×10, ×12.5, ×16.7, ×20, ×25, ×40, ×50, and ×100

Zoom position: The waveform is zoomed around the vertical position.

- **When variable is set to ON (vertical zoom/expand according to the upper and lower limits of the display range)**

Upper and lower limits:  $\pm 5.0000E+22$  [Value/Div]/ $\pm 1.0000E-23$  [Value/Div]

Display range: Up to  $\pm 5.0000E+21$ . ( $500.0E+18$  [Value/Div] × 10 [Div])

The display will be clipped at higher values.

- **Computation Delay**

[4 samples + the delay of the digital filter<sup>1</sup>]

Varies depending on the computation rate (100 kS/s maximum) of the DSP channel.

If the output result of a DSP channel is specified as a source of another DSP channel, the computation delay increases.

1. For details on the computation delay of the digital filter, see appendix 6.

#### Notes on Other Items

- When the DSP channel is ON, the sample rate of the analog channel is limited to 5 MS/s maximum.
- You must set the sample rate to 2 MS/s or lower before turning the DSP channel display ON or OFF.

# 15.2 Performing Addition, Subtraction, Multiplication, and Division (DSP Channels)

<For a description of this function, refer to page 2-50.>

## Procedure

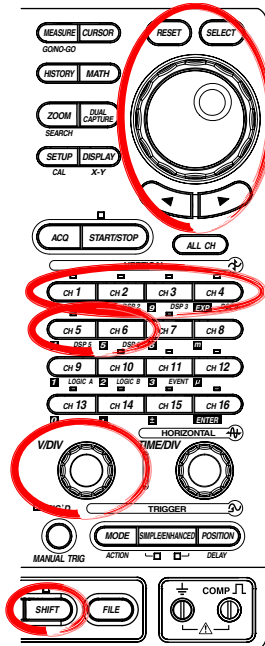

1. Press **SHIFT+CH1** to **CH6** (DSP1 to DSP6).

### Note

For a description of turning ON/OFF the DSP, see section 5.1. For a description of setting the vertical position, see section 5.4. For a description of zooming vertically by setting the zoom rate, see section 5.8. For a description of setting waveform labels, see section 8.10.

### Setting the Computation Definition

2. Press the **Setup** soft key. A setup dialog box opens.
3. Use the **jog shuttle** and **SELECT** to set Operation to  $S1+S2$ ,  $S1-S2$ ,  $S1*S2$ , or  $S1/S2$ .

### Selecting the Channel on Which to Perform Computation

4. Use the **jog shuttle** and **SELECT** to select Source1.
5. Likewise, select Source2

### Setting Value/Div

6. Turn the **V/DIV** knob to set the Value/Div value.  
You can also set Value/Div by pressing the **Value/Div** soft key and turning the **jog shuttle**.

### Note

There are 123 (selectable range:  $10.00E-21$  [Value/Div] to  $500.0E+18$  [Value/Div]) different Value/Div settings. You set the Value/Div using 1-2-5 steps similar to the V/div setting.

### Automatically Selecting the Optimum Value/Div Setting

7. Press the **Optimize Value/Div** soft key. The optimum Value/Div setting is automatically selected by referring to the range of the computed channel and displayed.

### Note

- The **Optimize Value/Div** soft key appears only when Variable is OFF.
- The operation using the **Optimize Value/Div** soft key selects the optimum Value/Div setting by referring to the range of the computed channel. It does not select the optimum Value/Div setting for the output waveform after computation. For easy viewing of the waveform after computation, select the approximate range using **Optimize Value/Div**, and then use the **V/DIV** knob or **Value/Div** soft key to adjust to the optimum range.

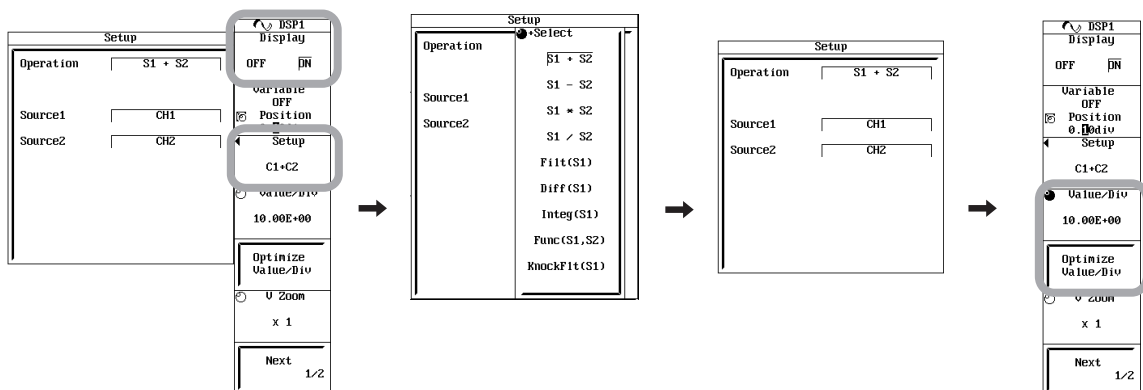

**Zooming in on the Waveform**

- **Zooming in or out Vertically by Setting the Zoom Rate**
  8. Press the **Variable** soft key to select OFF.
  9. Press the **V Zoom** soft key.
  10. Turn the **jog shuttle** to set the zoom rate.
  11. Press the **Variable** soft key to select Position.
  12. Turn the **jog shuttle** to set the vertical position. The center position of zoom changes. Proceed to step 13.
- **Zooming/Expanding Vertically According to the Upper and Lower Limits of the Display Range**
  8. Press the **Variable** soft key to select ON.
  9. Press the **Upper/Lower** soft key to set the jog shuttle control to Upper.
  10. Turn the **jog shuttle** to set the upper limit.
  11. Press the **Upper/Lower** soft key to set the jog shuttle control to Lower.
  12. Turn the **jog shuttle** to set the lower limit. Proceed to step 13.

**Setting the Waveform Label**

13. Press the **Next 1/2** soft key.
14. Press the **Label** soft key.
15. Enter the waveform label according to the procedure given in section 8.10.

**Setting the Unit**

16. Press the **Unit** soft key.
17. Enter the unit according to the procedure given in section 4.2.

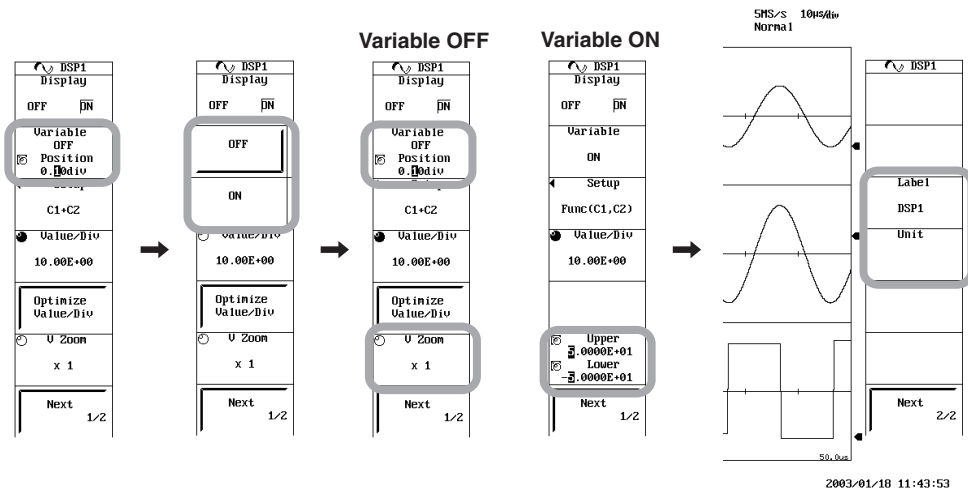



### Explanation

Addition, subtraction, multiplication, and division can be performed between channels.

#### **Computed Channels**

CH1 to CH16 and DSP1 to DSP6 (optional)

The computed result of a DSP channel can be specified as a computation source of another DSP channel, but only DSP channels with a channel number smaller than itself can be specified.

#### **Setting Value/Div**

Like V/div, Value/Div is set using 1-2-5 steps. The selectable range is 10.00E-21 [Value/Div] to 500.0E+18 [Value/Div] with 123 settings.

Turn the V/DIV knob to set the Value/Div value. You can also set Value/Div by pressing the Value/Div soft key and turning the jog shuttle.

#### **Automatically Selecting the Optimum Value/Div Setting**

When you press the Optimize Value/Div soft key, the optimum range is automatically selected from the 123 Value/Div settings, and the waveform is displayed using the selected setting.

#### **Zooming in on the Waveform**

- **Zooming in or out Vertically by Setting the Zoom Rate**

For details, see section 5.8, “Zooming Vertically by Setting the Zoom Rate” and “Notes Concerning Display” in section 15.1.

- **Zooming/Expanding Vertically According to the Upper and Lower Limits of the Display Range**

For details, see section 5.9, “Zooming Vertically According to the Upper and Lower Limits of the Display Range” and “Notes Concerning Display” in section 15.1.

#### **Setting the Unit**

Unit can be set arbitrarily using up to four characters. The specified characters are applied to the scale values.

#### **Note**

For other notes concerning DSP channels, see section 15.1.

# 15.3 Using Filters (DSP Channels)

<For a description of this function, refer to page 2-50.>

## Procedure

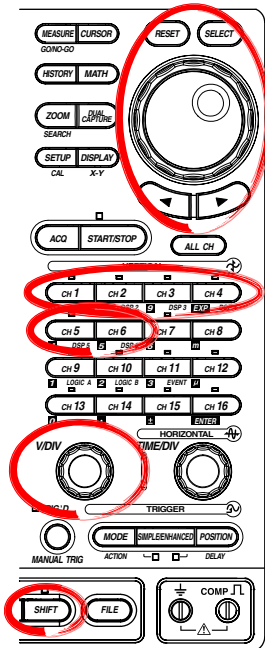

1. Press **SHIFT+CH1 to CH6** (DSP1 to DSP6).

### Note

For a description of turning ON/OFF the DSP, see section 5.1. For a description of setting the vertical position, see section 5.4. For a description of zooming vertically by setting the zoom rate, see section 5.8. For a description of setting waveform labels, see section 8.10.

### Setting the Computation Definition

2. Press the **Setup** soft key. A setup dialog box opens.
3. Use the **jog shuttle** and **SELECT** to set Operation to Filt(S1).

### Selecting the Channel on Which to Perform Computation

4. Use the **jog shuttle** and **SELECT** to select Source1.

### Setting the Filter

5. Use the **jog shuttle** and **SELECT** to set the Filter Type to Sharp, Gauss, IIR, or Mean.

#### • When Sharp or IIR Is Selected

6. Press the **Filter Band** soft key to select Low-Pass, High-Pass, or Band-Pass.
7. Use the **jog shuttle** and **SELECT** to set CutOff.  
If Filter Band is set to Band-Pass, set PassBand and Center Frequency. Proceed to step 8.

#### • When Gauss Is Selected

6. Press the **Filter Band** soft key to select Low-Pass. Only Low-Pass is available for Gauss.
7. Use the **jog shuttle** and **SELECT** to set CutOff. Proceed to step 8.

### Note

Set the cutoff frequency based on the current sampling frequency (fs) (100 kS/s maximum). If set above 100 kS/s, it is limited to 100 kS/s. The sampling frequency is also limited to 100 kS/s for envelope mode.

#### • When Mean Is Selected

6. Press the **TAP** soft key to set the stages to 2 to 128. Proceed to step 8.

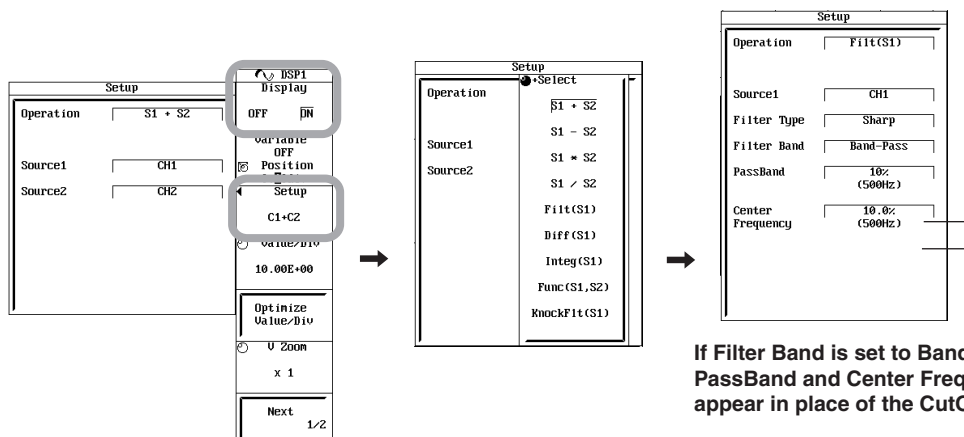

**Setting Value/Div**

- Turn the V/DIV knob to set the Value/Div value.  
You can also set Value/Div by pressing the **Value/Div** soft key and turning the **jog shuttle**.

**Note**

There are 123 (selectable range: 10.00E-21 [Value/Div] to 500.0E+18 [Value/Div]) different Value/Div settings. You set the Value/Div using 1-2-5 steps similar to the V/div setting.

**Automatically Selecting the Optimum Value/Div Setting**

- Press the **Optimize Value/Div** soft key. The optimum Value/Div setting is automatically selected by referring to the range of the computation channel and displayed.

**Note**

- The Optimize Value/Div soft key appears only when Variable is OFF.
- When using a filter, the range is set to the same range as the computed channel.

**Zooming in on the Waveform**

The procedure of “Zooming in or out Vertically by Setting the Zoom Rate” and “Zooming/Expanding Vertically According to the Upper and Lower Limits of the Display Range” is the same as the procedure described in section 15.2, “Performing Addition, Subtraction, Multiplication, and Division (DSP Channels).” See page 15-4.

**Setting the Waveform Label**

The procedure is the same as the procedure described in section 15.2, “Performing Addition, Subtraction, Multiplication, and Division (DSP Channels).” See page 15-4.

**Setting the Unit**

The procedure is the same as the procedure described in section 15.2, “Performing Addition, Subtraction, Multiplication, and Division (DSP Channels).” See page 15-4.

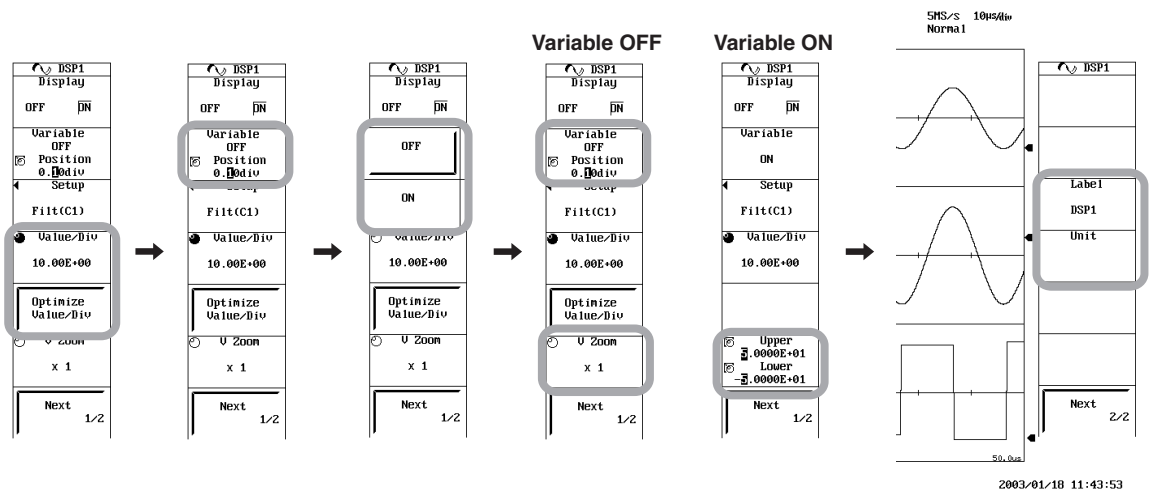

**Explanation**

A digital filter is used to perform the computation.

**Computed Channels**

CH1 to CH16 and DSP1 to DSP6 (optional)

The computed result of a DSP channel can be specified as a computation source of another DSP channel, but only DSP channels with a channel number smaller than itself can be specified.

**Setting the Digital Filter**

The following four types of filters are available. For details, see Appendix 6. Sharp, Gauss, Mean (moving average), and IIR (Butterworth)

Filter Format	Characteristics	Filter Type	Computation Type
Sharp	Steep attenuation slope (–40 dB per octave) Linear phase and constant group delay Ripple exists in the passband Stop band is comb-shaped	LPF <sup>1</sup> HPF <sup>1</sup> BPF <sup>1</sup>	FIR
Gauss	Gentle attenuation slope Linear phase and constant group delay No ripple in the passband There is no overshoot in the step response. Low order and small delay	LPF	FIR
MEAN (Moving Average)	Comb-shaped characteristics There is no overshoot in the step response. Linear phase and constant group delay	LPF	FIR
IIR (Butterworth)	Attenuation slope is between SHARP and GAUSS Not linear phase and group delay not constant No ripple in either passband or stopband Close to the characteristics of an analog filter Cutoff frequency can be set lower than SHARP/GAUSS	LPF HPF BPF	IIR

1. LPF, HPF, and BPF denote low-pass filter, high-pass filter, and bandpass filter, respectively.

The cutoff frequency, center frequency, and pass band can be specified in terms of percentages of fs (sampling frequency).

Type	Filter Band <sup>1</sup>	Cutoff Frequency <sup>2</sup>	Center Frequency <sup>3</sup>	Pass Band <sup>4</sup>	
Sharp	LPF	2.0% to 30.0%	-	-	
	HPF	2.0% to 30.0%	-	-	
	BPF	-	-	3.0% to 30.0%	2% of fs
		-	-	4.6% to 30.0%	5% of fs
		-	-	7.0% to 30.0%	10% of fs
		-	-	9.6% to 30.0%	15% of fs
-	-	12.0% to 30.0%	20% of fs		
Gauss	LPF	2.0% to 30.0%	-	-	
IIR	LPF	0.2% to 30.0%	-	-	
	HPF	0.2% to 30.0%	-	-	
	BPF	-	-	0.6% to 30.0%	1% of fs
		-	-	1.2% to 30.0%	2% of fs
		-	-	2.6% to 30.0%	5% of fs
		-	-	5.2% to 30.0%	10% of fs
-	-	7.6% to 30.0%	15% of fs		
-	-	10.2% to 30.0%	20% of fs		

1. LPF, HPF, and BPF denote low-pass filter, high-pass filter, and bandpass filter, respectively.
2. The cutoff frequency (CutOff) can be specified only when LPF or HPF is selected. The resolution is 0.2%.
3. The center frequency can be specified only when BPF is selected. The resolution is 0.2%.
4. The pass band can be specified only when BPF is selected. You can select the pass band from 1%, 2%, 5%, 10%, 15%, and 20%.

- **Setting the Number of Stages of Moving Average: TAP**

Select the number of stages from 2, 4, 8, 16, 32, 64, and 128.

For details on other filters, see appendix 6.

#### **Setting Value/Div**

Like V/div, Value/Div is set using 1-2-5 steps. The selectable range is 10.00E-21 [Value/Div] to 500.0E+18 [Value/Div] with 123 settings.

Turn the V/DIV knob to set the Value/Div value. You can also set Value/Div by pressing the Value/Div soft key and turning the jog shuttle.

#### **Automatically Selecting the Optimum Value/Div Setting**

When you press the Optimize Value/Div soft key, the optimum range is automatically selected from the 123 Value/Div settings, and the waveform is displayed using the selected setting.

#### **Zooming in on the Waveform**

- **Zooming in or out Vertically by Setting the Magnification**

For details, see section 5.8, “Zooming Vertically by Setting the Zoom Rate” and “Notes Concerning Display” in section 15.1.

- **Zooming/Expanding Vertically According to the Upper and Lower Limits of the Display Range**

For details, see section 5.9, “Zooming Vertically According to the Upper and Lower Limits of the Display Range” and “Notes Concerning Display” in section 15.1.

#### **Setting the Unit**

Unit can be set arbitrarily using up to four characters. The specified characters are applied to the scale values.

#### **Notes When Using Filters**

The following limitations exist depending on the acquisition mode setting.

- **When the Acquisition Mode Is Set to a Mode Other Than Envelope**

The digital filter frequency is set in terms of a percentage of the sampling frequency. For example, if the sampling frequency is 100 kHz and you set the cutoff frequency to 10%, the cutoff frequency is set to 10 kHz. If the sampling frequency exceeds 100 kHz, the sampling frequency of DSP channels is decimated to 100 kHz. Therefore, if the sampling frequency exceeds 100 kHz, the specified frequency is a percentage of 100 kHz regardless of the actual sampling frequency.

- **When the Acquisition Mode Is Set to Envelope**

The sampling frequency of DSP channels is fixed to 100 kHz. The digital filter frequency is set in terms of a percentage of 100 kHz.

#### **Note**

For other notes concerning DSP channels, see section 15.1.

# 15.4 Performing Differentiation and Integration (DSP Channels)

<For a description of this function, refer to page 2-50.>

## Procedure

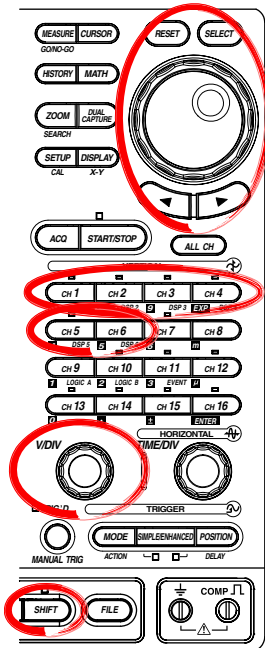

1. Press **SHIFT+CH1 to CH6** (DSP1 to DSP6).

### Note

For a description of turning ON/OFF the DSP, see section 5.1. For a description of setting the vertical position, see section 5.4. For a description of zooming vertically by setting the zoom rate, see section 5.8. For a description of setting waveform labels, see section 8.10.

### Setting the Computation Definition

2. Press the **Setup** soft key. A setup dialog box opens.
3. Use the **jog shuttle** and **SELECT** to set Operation to Diff(S1) (differentiation) or Integ(S1) (integration).

### Selecting the Channel on Which to Perform Computation

4. Use the **jog shuttle** and **SELECT** to select Source1.

### Setting Differentiation and Integration

#### • When Diff(S1) Is Selected

5. Use the **jog shuttle** and **SELECT** to set Filter to ON or OFF.
6. Use the **jog shuttle** and **SELECT** to set the CutOff in the range of 2.0% to 30.0%. Proceed to step 7.

#### • When Integ(S1) Is Selected (Selecting the Reset Condition)

5. Use the **jog shuttle** and **SELECT** to set the each item of Auto Reset Condition to ON/OFF. Proceed to step 7.

### Note

If Over Limit is turned ON, the computation is reset when the computed result exceeds +10 divisions or -10 divisions of the Value/Div setting. If Zero Cross to Positive is turned ON, the computation is reset when the signal of the target channel produces a positive edge at the zero-crossing point. If Zero Cross to Negative is turned ON, the computation is reset when the signal of the target channel produces a negative edge at the zero-crossing point. Multiple items can be selected simultaneously.

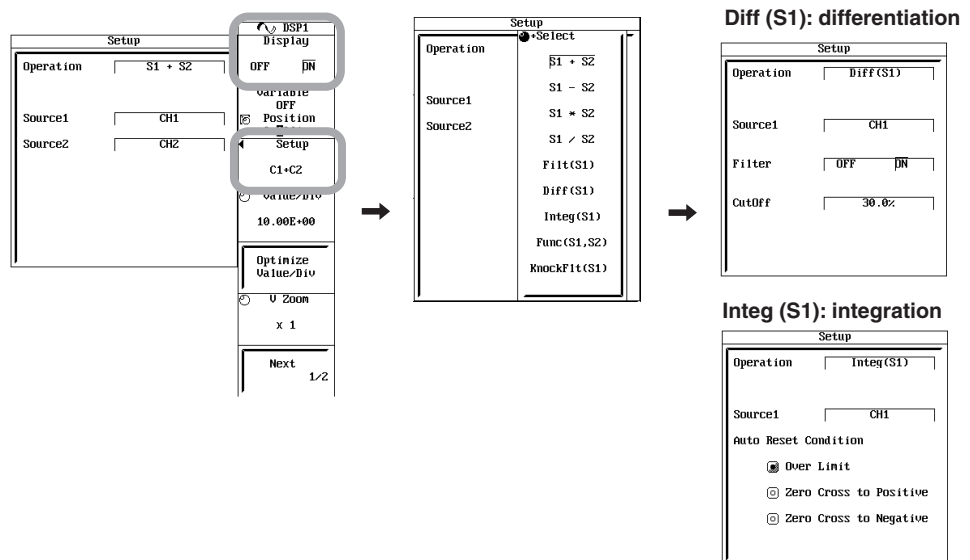

**Setting Value/Div**

- Turn the V/DIV knob to set the Value/Div value.  
You can also set Value/Div by pressing the **Value/Div** soft key and turning the **jog shuttle**.

**Note**

There are 123 (selectable range: 10.00E-21 [Value/Div] to 500.0E+18 [Value/Div]) different Value/Div settings. You set the Value/Div using 1-2-5 steps similar to the V/div setting.

**Automatically Selecting the Optimum Value/Div Setting**

- Press the **Optimize Value/Div** soft key. The optimum Value/Div setting is automatically selected by referring to the range of the computation channel and displayed.

**Note**

- The Optimize Value/Div soft key appears only when Variable is OFF.
- The operation using the Optimize Value/Div soft key selects the optimum Value/Div setting by referring to the range of the computed channel. It does not select the optimum Value/Div setting for the output waveform after computation. For easy viewing of the waveform after computation, select the approximate range using Optimize Value/Div, and then use the V/DIV knob or Value/Div soft key to adjust to the optimum range.

**Zooming in on the Waveform**

The procedure of “Zooming in or out Vertically by Setting the Zoom Rate” and “Zooming/Expanding Vertically According to the Upper and Lower Limits of the Display Range” is the same as the procedure described in section 15.2, “Performing Addition, Subtraction, Multiplication, and Division (DSP Channels).” See page 15-4.

**Setting the Waveform Label**

The procedure is the same as the procedure described in section 15.2, “Performing Addition, Subtraction, Multiplication, and Division (DSP Channels).” See page 15-4.

**Setting the Unit**

The procedure is the same as the procedure described in section 15.2, “Performing Addition, Subtraction, Multiplication, and Division (DSP Channels).” See page 15-4.

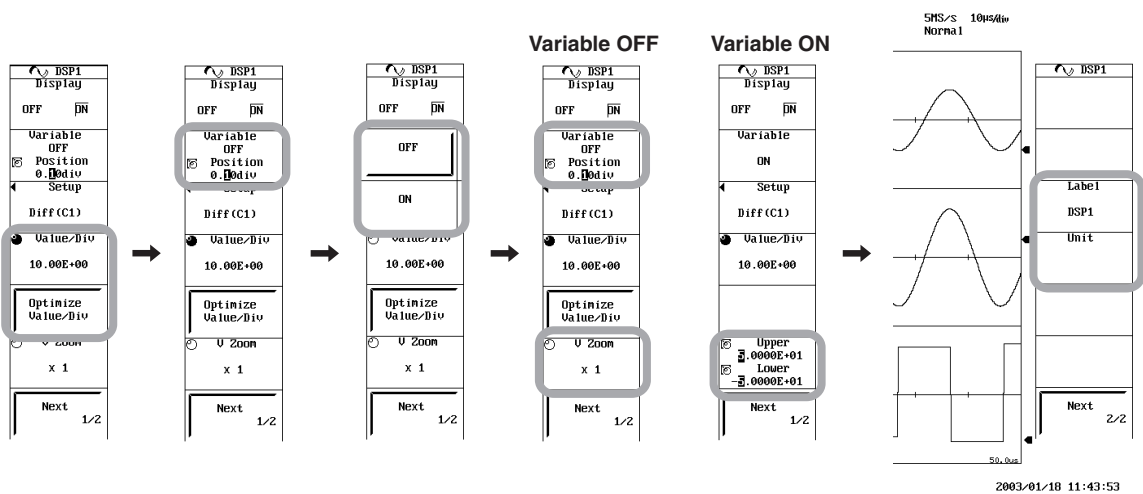

### **Explanation**

Differentiation or integration is performed on the specified waveform.

#### **Computed Channels**

CH1 to CH16 and DSP1 to DSP6 (optional)

The computed result of a DSP channel can be specified as a computation source of another DSP channel, but only DSP channels with a channel number smaller than itself can be specified.

#### **Setting the Cutoff Frequency of Differentiation**

In the differentiation of DSP channels, differentiation can be performed after passing the input signal through a low-pass filter. The low-pass filter is a SHARP low-pass filter. For details on differentiation, see page app-44.

Selectable range of cutoff frequency: 2.0% to 30.0% of the sample rate (0.2% steps)

#### **Setting the Reset Condition of Integration: Auto Reset Condition**

Usually, the integration result is reset when waveform acquisition is started or when the target channel is turned ON/OFF. You can also set the following types of reset conditions. Multiple items can be selected simultaneously.

Over Limit: Reset when the computed result exceeds +10 division or –10 divisions of the Value/Div setting.

Zero Cross to Positive: Reset when the target channel produces a positive edge at the zero-crossing point.

Zero Cross to Negative: Reset when the target channel produces a negative edge at the zero-crossing point.

#### **Setting Value/Div**

Like V/div, Value/Div is set using 1-2-5 steps. The selectable range is 10.00E–21 [Value/Div] to 500.0E+18 [Value/Div] with 123 settings.

Turn the V/DIV knob to set the Value/Div value. You can also set Value/Div by pressing the Value/Div soft key and turning the jog shuttle.

#### **Automatically Selecting the Optimum Value/Div Setting**

When you press the Optimize Value/Div soft key, the optimum range is automatically selected from the 123 Value/Div settings, and the waveform is displayed using the selected setting.

#### **Zooming in on the Waveform**

- **Zooming in or out Vertically by Setting the Magnification**

For details, see section 5.8, “Zooming Vertically by Setting the Zoom Rate” and “Notes Concerning Display” in section 15.1.

- **Zooming/Expanding Vertically According to the Upper and Lower Limits of the Display Range**

For details, see section 5.9, “Zooming Vertically According to the Upper and Lower Limits of the Display Range” and “Notes Concerning Display” in section 15.1.

#### **Setting the Unit**

Unit can be set arbitrarily using up to four characters. The specified characters are applied to the scale values.

#### **Note**

---

For other notes concerning DSP channels, see section 15.1.

---



# 15.5 Performing Addition, Subtraction, Multiplication, and Division with Coefficients (DSP Channels)

<For a description of this function, refer to page 2-50.>

## Procedure

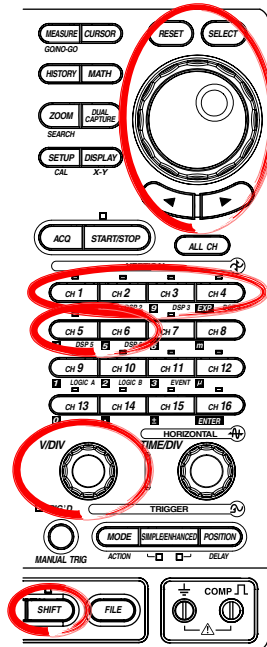

1. Press **SHIFT+CH1 to CH6** (DSP1 to DSP6).

### Note

For a description of turning ON/OFF the DSP, see section 5.1. For a description of setting the vertical position, see section 5.4. For a description of zooming vertically by setting the zoom rate, see section 5.8. For a description of setting waveform labels, see section 8.10.

### Setting the Computation Definition

2. Press the Setup soft key. A setup dialog box opens.
3. Use the **jog shuttle** and **SELECT** to set Operation to Func(S1, S2).
4. Use the **jog shuttle** and **SELECT** to select the Expression from the following.
  - (A\*S1)+(B\*S2)+C
  - (A\*S1)-(B\*S2)+C
  - (A\*S1)\*(B\*S2)+C
  - (A\*S1)/(B\*S2)+C

### Selecting the Channel on Which to Perform Computation

5. Use the **jog shuttle** and **SELECT** to select Source1.
6. Likewise, select Source2

### Setting the coefficient

7. Use the **jog shuttle** and **SELECT** to set coefficient A.
8. Likewise, set coefficients B and C.

### Note

The selectable range of coefficients A, B, and C is  $\pm 9.9999E-30$  to  $\pm 9.9999E+30$ .

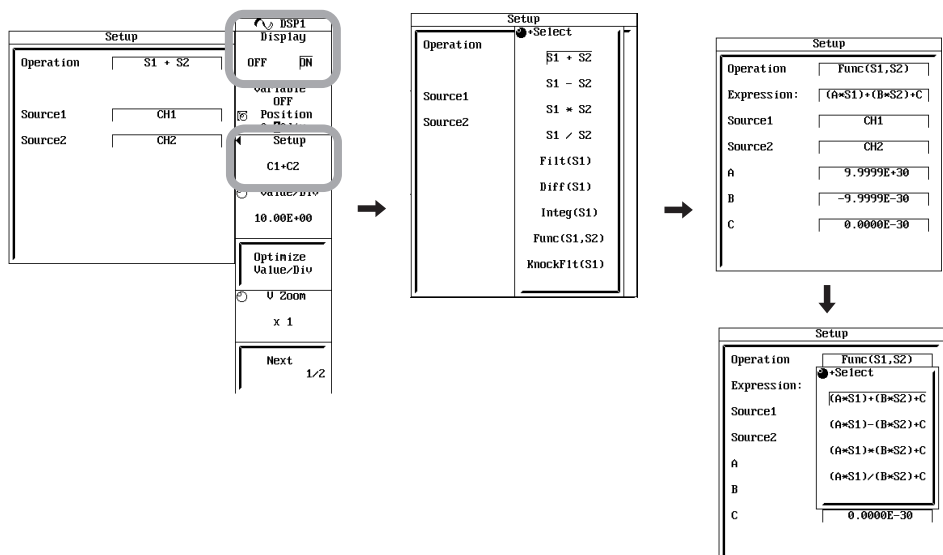

## 15.5 Performing Addition, Subtraction, Multiplication, and Division with Coefficients (DSP Channels)

### Setting Value/Div

- Turn the V/DIV knob to set the Value/Div value.  
You can also set Value/Div by pressing the **Value/Div** soft key and turning the **jog shuttle**.

### Note

There are 123 (selectable range: 10.00E-21 [Value/Div] to 500.0E+18 [Value/Div]) different Value/Div settings. You set the Value/Div using 1-2-5 steps similar to the V/div setting.

### Automatically Selecting the Optimum Value/Div Setting

- Press the **Optimize Value/Div** soft key. The optimum Value/Div setting is automatically selected by referring to the range of the computation channel and displayed.

### Note

- The Optimize Value/Div soft key appears only when Variable is OFF.
- The operation using the Optimize Value/Div soft key selects the optimum Value/Div setting by referring to the range of the computed channel. It does not select the optimum Value/Div setting for the output waveform after computation. For easy viewing of the waveform after computation, select the approximate range using Optimize Value/Div, and then use the V/DIV knob or Value/Div soft key to adjust to the optimum range.

### Zooming in on the Waveform

The procedure of “Zooming in or out Vertically by Setting the Zoom Rate” and “Zooming/Expanding Vertically According to the Upper and Lower Limits of the Display Range” is the same as the procedure described in section 15.2, “Performing Addition, Subtraction, Multiplication, and Division (DSP Channels).” See page 15-4.

### Setting the Waveform Label

The procedure is the same as the procedure described in section 15.2, “Performing Addition, Subtraction, Multiplication, and Division (DSP Channels).” See page 15-4.

### Setting the Unit

The procedure is the same as the procedure described in section 15.2, “Performing Addition, Subtraction, Multiplication, and Division (DSP Channels).” See page 15-4.

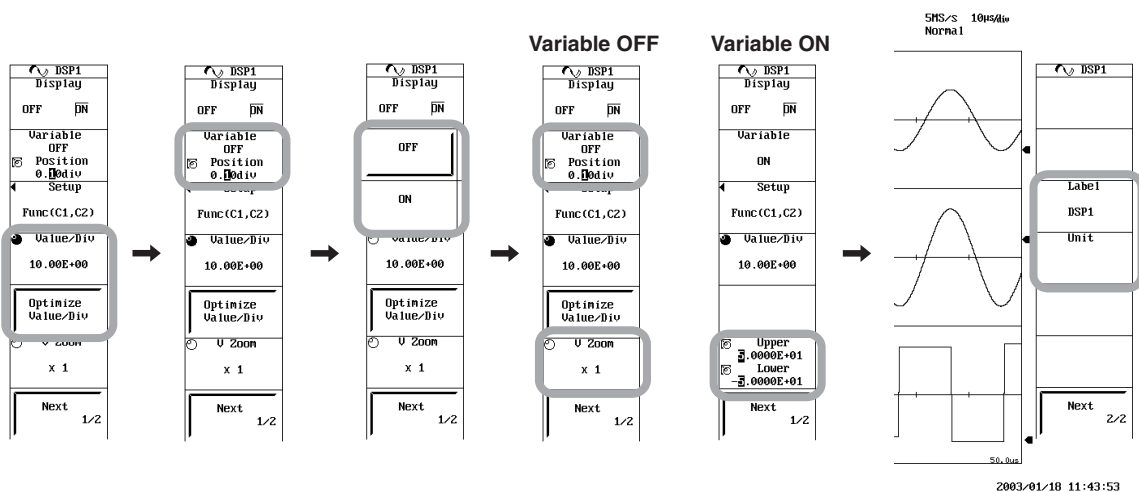

**Explanation**

Addition, subtraction, multiplication, and division with coefficients can be performed between channels.

**Computed Channels**

CH1 to CH16 and DSP1 to DSP6 (optional)

The computed result of a DSP channel can be specified as a computation source of another DSP channel, but only DSP channels with a channel number smaller than itself can be specified.

**Types of Addition, Subtraction, Multiplication, and Division with Coefficients**

$(A*S1)+(B*S2)+C$

$(A*S1)-(B*S2)+C$

$(A*S1)*(B*S2)+C$

$(A*S1)/(B*S2)+C$

**Selectable Range of Coefficients**

The selectable range of coefficients A, B, and C is  $-9.9999E+30$  to  $-0.0001E-30$ , 0, and  $+0.0001E-30$  to  $+9.9999E+30$ .

**Setting Value/Div**

Like V/div, Value/Div is set using 1-2-5 steps. The selectable range is  $10.00E-21$  [Value/Div] to  $500.0E+18$  [Value/Div] with 123 settings.

Turn the V/DIV knob to set the Value/Div value. You can also set Value/Div by pressing the Value/Div soft key and turning the jog shuttle.

**Automatically Selecting the Optimum Value/Div Setting**

When you press the Optimize Value/Div soft key, the optimum range is automatically selected from the 123 Value/Div settings, and the waveform is displayed using the selected setting.

**Zooming in on the Waveform**

- **Zooming in or out Vertically by Setting the Magnification**

For details, see section 5.8, “Zooming Vertically by Setting the Zoom Rate” and “Notes Concerning Display” in section 15.1.

- **Zooming/Expanding Vertically According to the Upper and Lower Limits of the Display Range**

For details, see section 5.9, “Zooming Vertically According to the Upper and Lower Limits of the Display Range” and “Notes Concerning Display” in section 15.1.

**Setting the Unit**

Unit can be set arbitrarily using up to four characters. The specified characters are applied to the scale values.

**Note**

For other notes concerning DSP channels, see section 15.1.

# 15.6 Using the Knocking Filter (DSP Channels)

<For a description of this function, refer to page 2-50.>

## Procedure

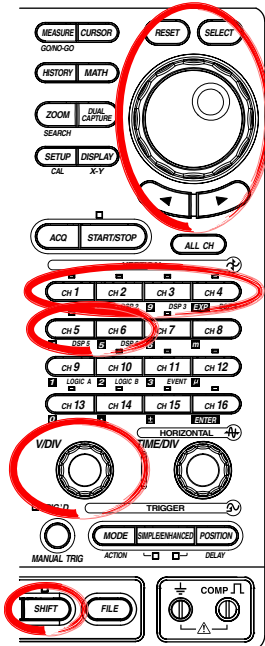

1. Press **SHIFT+CH1 to CH6** (DSP1 to DSP6).

### Note

For a description of turning ON/OFF the DSP, see section 5.1. For a description of setting the vertical position, see section 5.4. For a description of zooming vertically by setting the zoom rate, see section 5.8. For a description of setting waveform labels, see section 8.10.

### Setting the Computation Definition

2. Press the **Setup** soft key. A setup dialog box opens.
3. Use the **jog shuttle** and **SELECT** to set Operation to KnockFit(S1).

### Selecting the Channel on Which to Perform Computation

4. Use the **jog shuttle** and **SELECT** to select Source1.

### Setting the Filter

5. Use the **jog shuttle** and **SELECT** to set the Filter Type to Sharp, IIR, or Diff.

#### • When Sharp or IIR Is Selected

6. Use the **jog shuttle** and **SELECT** to set the Filter Band to High-Pass or Band-Pass.
7. If you selected High-Pass in step 6, use the **jog shuttle** and **SELECT** to set CutOff. If you selected Band-Pass, use the **jog shuttle** and **SELECT** to set PassBand and Center Frequency. Proceed to step 8.

#### • When Diff Is Selected

6. Use the **jog shuttle** and **SELECT** to set Filter to ON or OFF.
7. Use the **jog shuttle** and **SELECT** to set CutOff. Proceed to step 8.

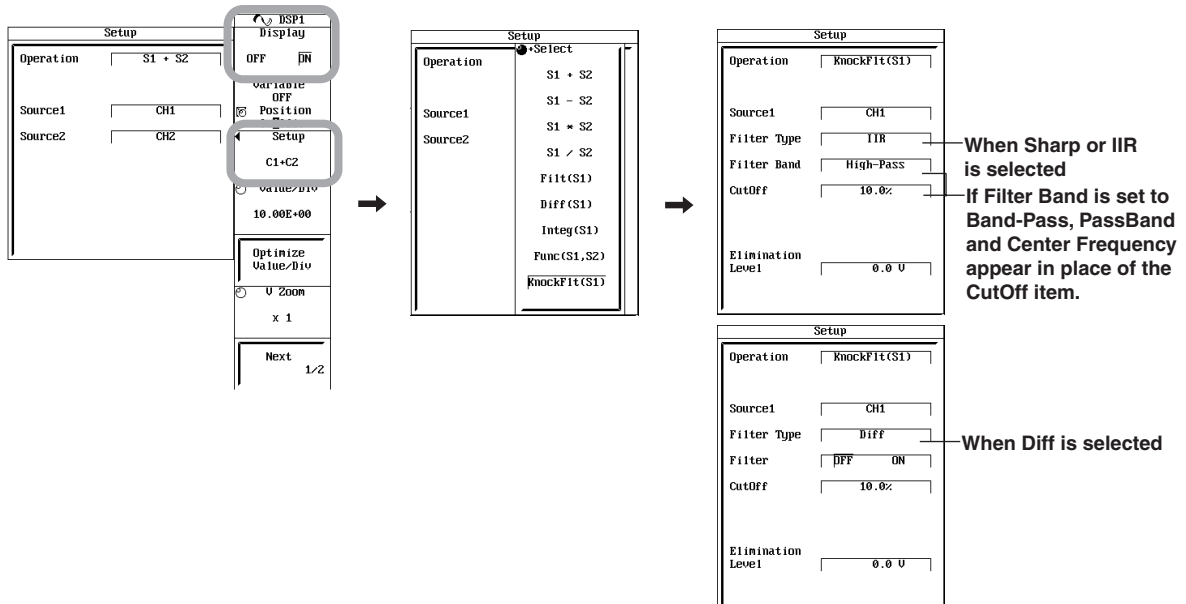

### Note

Set the cutoff frequency based on the current sampling frequency ( $f_s$ ) (100 kS/s maximum). If set above 100 kS/s, it is limited to 100 kS/s. The sampling frequency is also limited to 100 kS/s for envelope mode.

**Setting the Elimination Level**

- Use the **jog shuttle** and **SELECT** to set Elimination Level. Press ESC.

**Setting Value/Div**

- Turn the V/DIV knob to set the Value/Div value.  
You can also set Value/Div by pressing the **Value/Div** soft key and turning the **jog shuttle**.

**Note**

There are 123 (selectable range: 10.00E-21 [Value/Div] to 500.0E+18 [Value/Div]) different Value/Div settings. You set the Value/Div using 1-2-5 steps similar to the V/div setting.

**Automatically Selecting the Optimum Value/Div Setting**

- Press the **Optimize Value/Div** soft key. The optimum Value/Div setting is automatically selected by referring to the range of the computation channel and displayed.

**Note**

- The Optimize Value/Div soft key appears only when Variable is OFF.
- When using the knocking filter, the range is set to the same range as the computed channel.

**Zooming in on the Waveform**

The procedure of “Zooming in or out Vertically by Setting the Zoom Rate” and “Zooming/ Expanding Vertically According to the Upper and Lower Limits of the Display Range” is the same as the procedure described in section 15.2, “Performing Addition, Subtraction, Multiplication, and Division (DSP Channels).” See page 15-4.

**Setting the Waveform Label**

The procedure is the same as the procedure described in section 15.2, “Performing Addition, Subtraction, Multiplication, and Division (DSP Channels).” See page 15-4.

**Setting the Unit**

The procedure is the same as the procedure described in section 15.2, “Performing Addition, Subtraction, Multiplication, and Division (DSP Channels).” See page 15-4.

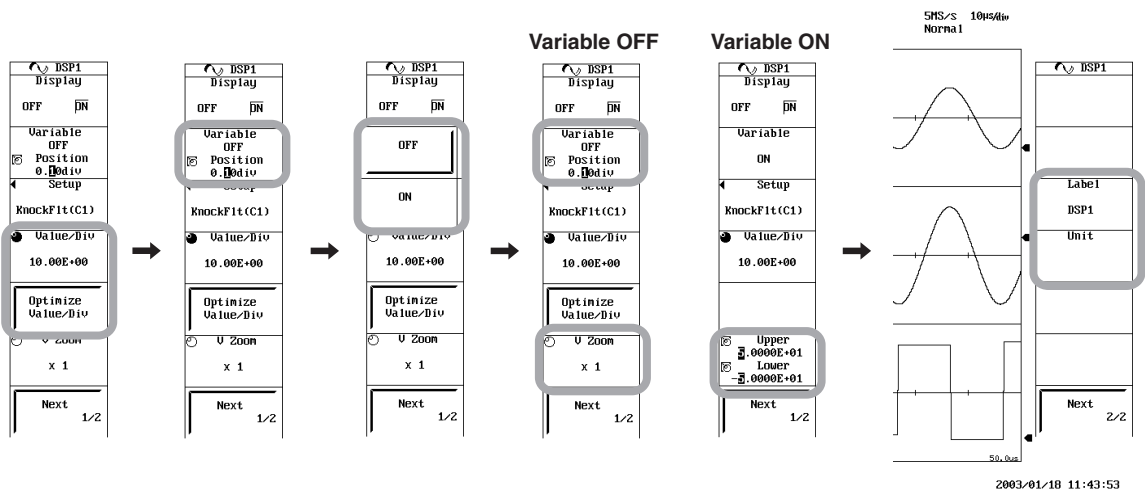

## 15.6 Using the Knocking Filter (DSP Channels)

### Explanation

When the value of the computed channel is greater than the elimination level, filter computation is performed. If the value is less than the elimination level, the computed result is set to 0. This filter is effective such as when extracting only the knocking components from the pressure inside the engine cylinder.

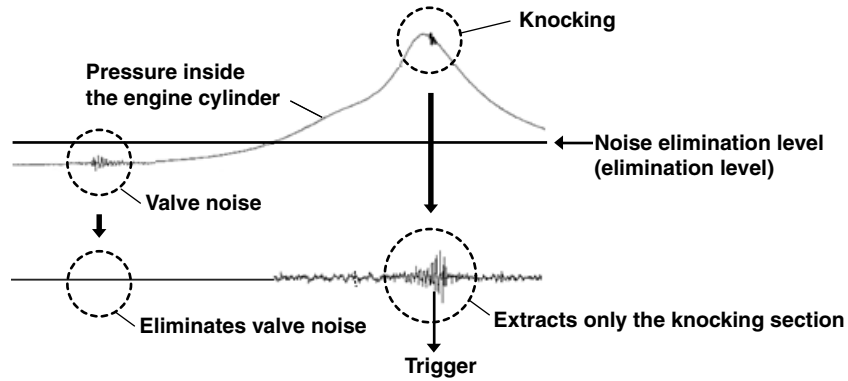

### Computed Channels

CH1 to CH16 and DSP1 to DSP6 (optional)

The computed result of a DSP channel can be specified as a computation source of another DSP channel, but only DSP channels with a channel number smaller than itself can be specified.

### Digital Filter That Can Be Used in the Knocking Filter

The following three digital filters can be specified. (For details, see appendix 6.)  
Sharp, IIR (Butterworth), and Diff (differentiation)

Filter Format	Characteristics	Filter Type	Computation Type
SHARP	Attenuation slope of the frequency response is steep (-40 dB per octave)	HPF*	FIR
	Linear phase and constant group delay Ripple exists in the passband Stop band is comb-shaped	BPF*	
IIR (Butterworth)	Attenuation slope is between SHARP and GAUSS	HPF	IIR
	Not linear phase and group delay not constant No ripple in either passband or stopband Close to the characteristics of an analog filter Cutoff frequency can be set lower than SHARP/GAUSS	BPF	
Diff (differentiation)	Performs the same computation as the differentiation described in section 15.4.		

\* HPF: High-pass filter, BPF: Band-pass filter

The cutoff frequency, center frequency, and pass band can be specified in terms of percentages of fs (sampling frequency).

Type	Filter Band <sup>1</sup>	Cutoff Frequency <sup>2</sup>	Center Frequency <sup>3</sup>	Pass Band <sup>4</sup>
Sharp	HPF	2.0% to 30.0%	-	-
	BPF	-	3.0% to 30.0%	2% of fs
		-	4.6% to 30.0%	5% of fs
		-	7.0% to 30.0%	10% of fs
		-	9.6% to 30.0%	15% of fs
-	12.0% to 30.0%	20% of fs		
IIR	HPF	0.2% to 30.0%	-	-
	BPF	-	0.6% to 30.0%	1% of fs
		-	1.2% to 30.0%	2% of fs
		-	2.6% to 30.0%	5% of fs
		-	5.2% to 30.0%	10% of fs
		-	7.6% to 30.0%	15% of fs
-	10.2% to 30.0%	20% of fs		

Diff (differentiation) Performs the same computation as the differentiation described in section 15.4.

- 1 HPF: High-pass filter, BPF: Band-pass filter
- 2 The cutoff frequency (CutOff) can be specified only when HPF is selected. The resolution is 0.2%.
- 3 The center frequency can be specified only when BPF is selected. The resolution is 0.2%.
- 4 The pass band can be specified only when BPF is selected. You can select the pass band from 1%, 2%, 5%, 10%, 15%, and 20%.

### Setting the Elimination Level

Set the reference level for noise elimination. The selectable range and resolution of the elimination level are the same as those of the trigger level. See section 6.5.

### Setting Value/Div

Like V/div, Value/Div is set using 1-2-5 steps. The selectable range is 10.00E-21 [Value/Div] to 500.0E+18 [Value/Div] with 123 settings.

Turn the V/DIV knob to set the Value/Div value. You can also set Value/Div by pressing the Value/Div soft key and turning the jog shuttle.

### Automatically Selecting the Optimum Value/Div Setting

When you press the Optimize Value/Div soft key, the optimum range is automatically selected from the 123 Value/Div settings, and the waveform is displayed using the selected setting.

### Zooming in on the Waveform

- **Zooming in or out Vertically by Setting the Magnification**

For details, see section 5.8, “Zooming Vertically by Setting the Zoom Rate” and “Notes Concerning Display” in section 15.1.

- **Zooming/Expanding Vertically According to the Upper and Lower Limits of the Display Range**

For details, see section 5.9, “Zooming Vertically According to the Upper and Lower Limits of the Display Range” and “Notes Concerning Display” in section 15.1.

## 15.6 Using the Knocking Filter (DSP Channels)

---

### **Setting the Unit**

Unit can be set arbitrarily using up to four characters. The specified characters are applied to the scale values.

### **Notes When Using the Knocking Filter**

The following limitations exist depending on the acquisition mode setting.

- **When the Acquisition Mode Is Set to a Mode Other Than Envelope**

The digital filter frequency is set in terms of a percentage of the sampling frequency. For example, if the sampling frequency is 100 kHz and you set the cutoff frequency to 10%, the cutoff frequency is set to 10 kHz. If the sampling frequency exceeds 100 kHz, the sampling frequency of DSP channels is decimated to 100 kHz. Therefore, if the sampling frequency exceeds 100 kHz, the specified frequency is a percentage of 100 kHz regardless of the actual sampling frequency.

- **When the Acquisition Mode Is Set to Envelope**

The sampling frequency of DSP channels is fixed to 100 kHz. The digital filter frequency is set in terms of a percentage of 100 kHz.

### **Note**

---

For other notes concerning DSP channels, see section 15.1.

---



## 16.1 Connecting the DL750/DL750P to the Network

<For a description of this function, refer to page 2-59.>

### Ethernet Interface Specifications

A 100BASE-TX port is provided on the left side panel of the DL750/DL750P.

Item	Specifications
Number of communication ports	1
Electrical and mechanical specifications	Conforms to IEEE802.3
Transmission system	Ethernet (100BASE-TX/10BASE-T)
Transmission rate	100 Mbps max.
Communication protocol	TCP/IP
Supported services	FTP server, FTP client (network drive), LPR client (network printer), SMTP client (mail transmission), DHCP, DNS, and Web server
Connector type	RJ-45 connector

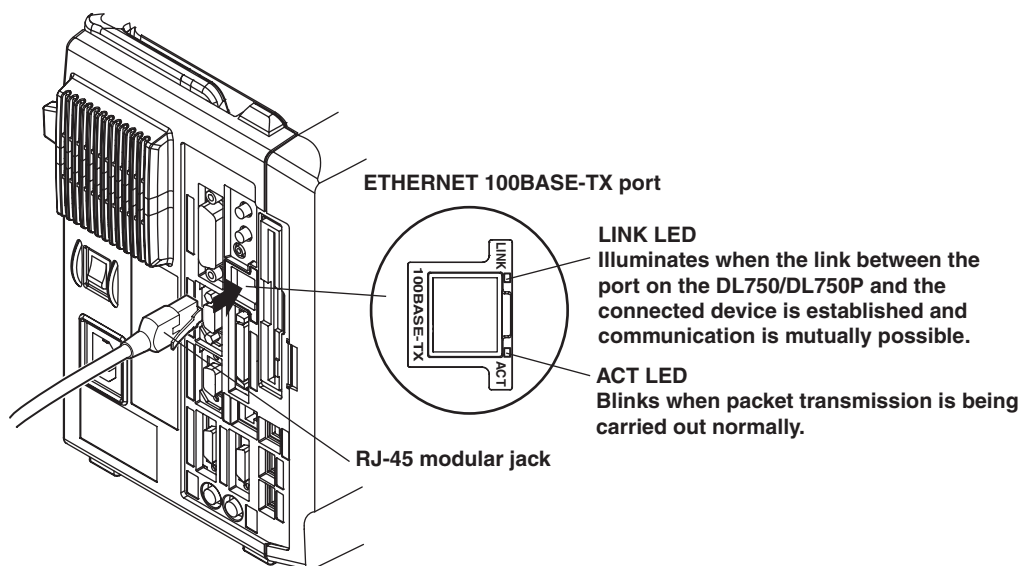

### Items Necessary for Connection

#### Cable

Be sure to use one the following cables for connection.

- UTP (Unshielded Twisted-Pair) cable (category 5 or better)
- STP (Shielded Twisted-Pair) cable (category 5 or better)

## 16.1 Connecting the DL750 to a PC or Workstation via the Ethernet Interface (Optional)

---

### Connection Procedure

#### When Connecting to a Network PC or Workstation

1. Turn OFF the DL750/DL750P.
2. Connect one end of the UTP (or STP) cable to the ETHERNET 100BASE-TX terminal on the left side panel.
3. Connect the other end of the UTP (or STP) cable to a hub or router.
4. Turn ON the DL750/DL750P.

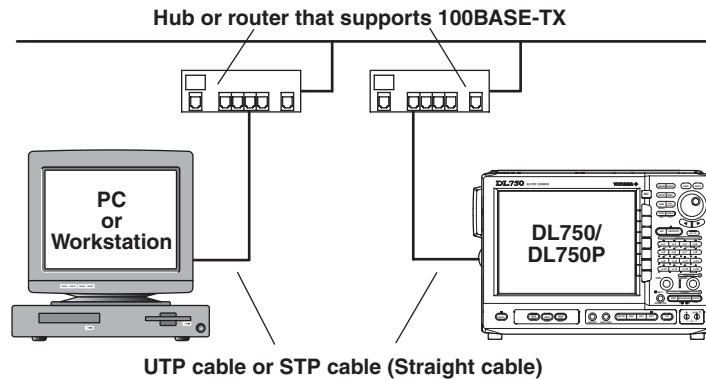

#### When Making a One-to-One Connection to the PC or Workstation

1. Turn OFF the DL750/DL750P and the PC or workstation.
2. Connect one end of the UTP (or STP) cable to the ETHERNET 100BASE-TX terminal on the left side panel.
3. Connect the other end of the UTP (or STP) cable to a hub or router.
4. Likewise, connect the PC or workstation to a hub or router.
5. Turn ON the DL750/DL750P.

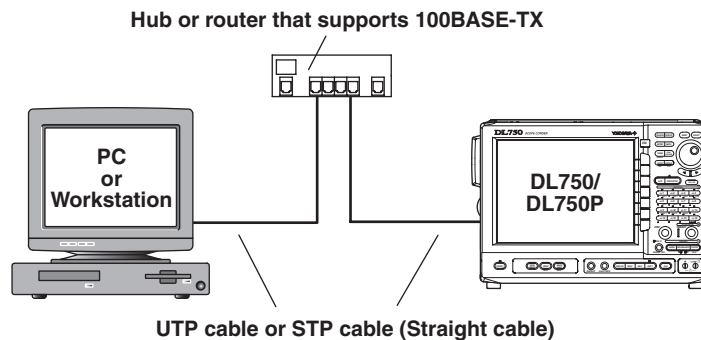

#### Note

- When connecting the PC or workstation one-to-one, a NIC (a 10BASE-T/100BASE-TX autoswitching card) is required for the PC or workstation.
  - When using a UTP cable or STP cable (straight cable), be sure to use only a category 5 cable.
  - Avoid connecting the PC or workstation directly to the DL750/DL750P without going through the hub or router. Operations are not guaranteed for communications using direct connection.
-

## 16.2 Setting up the TCP/IP

### Procedure

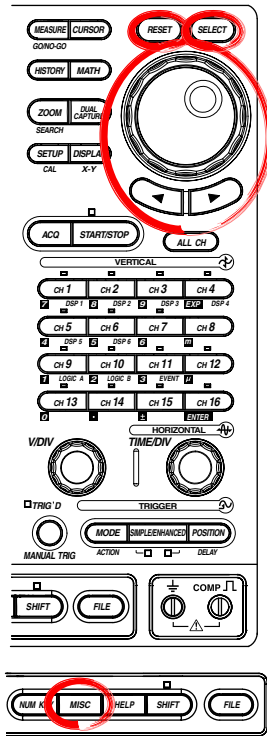

1. Press **MISC**.
2. Press the **Network** soft key.
3. Press the **TCP/IP Setup** soft key. The TCP/IP setup menu appears.

### Turning DHCP ON/OFF

4. Use the **jog shuttle** and **SELECT** to set DHCP to ON or OFF.

If you DHCP to OFF, proceed to step 5.

If the DHCP is set to ON, you do not have to set the IP address, subnet mask, and default gateway.

- To set up the DNS, proceed to step 11.
- If you do not wish to set up the DNS, check the network cable connection and restart the DL750/DL750P. The IP address, subnet mask, and default gateway are automatically configured.

### Setting the IP Address

Set the IP address if you turned DHCP OFF.

5. Use the **jog shuttle** and **SELECT** to set the IP Address. Enter using values in the range of 0 to 255.

### Setting the Subnet Mask

Set the subnet mask if you turned DHCP OFF.

6. Use the **jog shuttle** and **SELECT** to set the Net Mask. Enter using values in the range of 0 to 255.

### Setting the Default Gateway

Set the default gateway if you turned DHCP OFF.

7. Use the **jog shuttle** and **SELECT** to set the Gate Way. Enter using values in the range of 0 to 255.

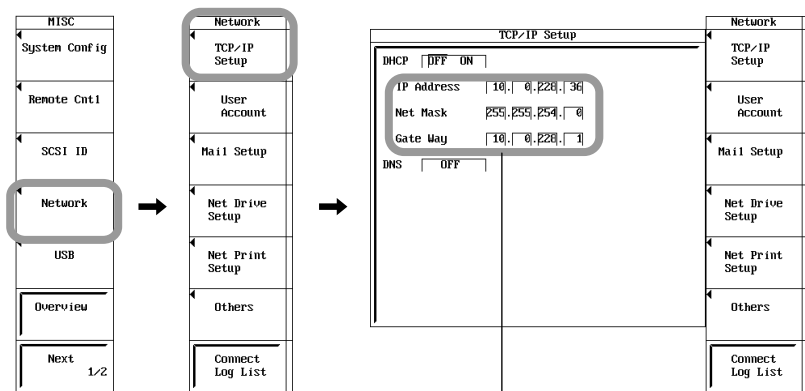

Automatically configured when DHCP is turned ON.

**Setting the DNS**

- 8. Use the **jog shuttle** and **SELECT** to set DNS to ON, OFF, or AUTO. (AUTO can be specified when DHCP is ON.)  
When DNS is set to AUTO, the domain name and DNS server name are automatically configured by power-cycling the DL750/DL750P.  
If DNS is set to ON, the domain name, DNS server name, and domain suffix are displayed.  
If DNS is set to OFF, check the network cable connection and power cycle the DL750/DL750P.

**Setting the Domain Name**

- 9. Use the **jog shuttle** and **SELECT** to select Domain Name.
- 10. Enter the domain name according to the procedure given in section 4.2.

**Setting the DNS Server**

- 11. Use the **jog shuttle** and **SELECT** to set DNS Server1 (primary DNS server). Enter using values in the range of 0 to 255.
- 12. Likewise, set the secondary DNS server in DNS Server2.

**Setting the Domain Suffix**

- 13. Use the **jog shuttle** and **SELECT** to set Domain Suffix1 (primary domain suffix).
- 14. Likewise, set the secondary domain suffix in Domain Suffix2.

**Note**

For keyboard (soft keyboard) operation, see section 4.2, "Entering Values and Strings."

**Turning ON/OFF the Power**

- 15. To apply the new settings, the DL750/DL750P must be power cycled. After all the settings are complete, turn the power to the DL750/DL750P OFF, then back ON again.

The image shows a screenshot of the 'TCP/IP Setup' menu. The menu is titled 'TCP/IP Setup' and contains the following options and fields:

- DHCP: [OFF ON]
- IP Address: [10].[0].[220].[36]
- Net Mask: [255].[255].[255].[0]
- Gate Way: [10].[0].[220].[1]
- DNS: [ON]
- Domain Name: [ ]
- DNS Server1: [10].[0].[252].[19]
- DNS Server2: [0].[0].[0].[0]
- Domain Suffix1: [ ]
- Domain Suffix2: [ ]

On the right side of the screen, there is a vertical menu titled 'Network' with the following options:

- TCP/IP Setup
- User Account
- Mail Setup
- Net Drive Setup
- Net Print Setup
- Others
- Connect
- Log List

## Explanation

The following TCP/IP settings must be entered to use the Ethernet communications functions on the DL750/DL750P.

- IP address
- Subnet mask
- Default gateway

### **IP Address (Internet Protocol Address)**

Set the IP address to assign to the DL750/DL750P. The default setting is “0.0.0.0.”

The IP address is an ID that is assigned to each PC on an IP network such as the internet or an intranet. The address is a 32-bit value expressed using four octets (each 0 to 255), each separated by a period as in [192.168.111.24].

Obtain an IP address from your network administrator. The setting is automatically configured in environments using DHCP.

### **Subnet Mask (Net Mask)**

Set the mask value used when determining the subnet network address from the IP address. The default setting is “255.255.255.0.”

Huge TCP/IP networks such as the Internet are often divided up into smaller networks called sub networks. The subnet mask is a 32 bit value that specifies the number of bits of the IP address used to identify the network address. The portion other than the network address is the host address that identifies individual computers on the network. Consult your network administrator for the subnet mask value. You may not need to set the value. The setting is automatically configured in environments using DHCP.

### **Default Gateway**

Set the IP address of the gateway (default gateway) used to communicate with other networks. The default setting is “0.0.0.0.”

The default gateway has control functions that handle protocol exchanges when communicating with multiple networks, so that data transmission is carried out smoothly.. Consult your network administrator for the default gateway value. You may not need to set the value. The setting is automatically configured in environments using DHCP.

### **DHCP (Dynamic Host Configuration Protocol)**

DHCP is a protocol that allocates setup information that are needed temporarily to the PCs connecting to the network. When DHCP is turned ON, the following settings are automatically assigned.

- IP address
- Subnet mask
- Default gateway
- DNS

To use DHCP, the network must have a DHCP server. Consult your network administrator to see if DHCP can be used.

When DHCP is turned ON, different settings may be assigned each time the power is turned ON. When using the FTP server function (see section 16.6), be sure to check the IP address and other settings of the DL750/DL750P using a PC or workstation each time you turn ON the DL750/DL750P.

**DNS (Domain Name System)**

DNS is a system used to associate names used on the Internet called host names and domain names to IP addresses. (Given AAA.BBBBB.com, AAA is the host name and BBBBB.com is the domain name.) Instead of using the IP address, which is a sequence of numbers, host name and domain name can be used to access the network.

On the DL750/DL750P, you can specify the host by name instead of by IP address when using the FTP client function (see section 16.3) or network printer function (see sections 16.4 and 12.4).

Set the domain name, the DNS server address (“0.0.0.0” by default), and the domain suffix. In networks that support DHCP, these settings can be configured automatically. For details, consult your network administrator.

- **DNS Server: DNS Server1/DNS Server2**  
Up to two DNS server addresses can be specified (primary and secondary). If the primary DNS server is down, the secondary DNS server is automatically looked up for the mapping of the host name/domain name and IP address.
- **Domain Suffix: Domain Suffix1/Domain Suffix2**  
When the IP address corresponding to the server name with the aforementioned domain name is not found, the system may be set up to search using a different domain name. Enter this alternate domain name as the domain suffix. Up to two domain suffixes can be specified, Domain Suffix1 (primary), and Domain Suffix2 (secondary).

**Note**

- If you changed settings related to the Ethernet network, the DL750/DL750P must be power cycled.
- If the DL750/DL750P is turned ON with the DHCP function enabled without an Ethernet cable connected, communications and file functions may not operate properly. In this case, turn DHCP OFF and power cycle the DL750/DL750P.
- **Configuring the TCP/IP Settings of the PC**  
Communication parameters such as the IP address must also be specified on the PC side. Communication parameters are specified for each Ethernet NIC that is installed in the PC. Here, the settings of the NIC for connecting your PC and the DL750/DL750P are explained.  
If the IP address and other parameters are to be obtained dynamically using the DHCP server, the following settings are not necessary. In this case, select **Obtain an IP address automatically** under the **IP Address** tab of the **TCP/IP Properties** dialog box. For example, if you are connecting a PC and the DL750/DL750P to an independent Ethernet network, you can specify parameters as indicated in the next table. For details on the parameters, consult your system or network administrator.

Parameter	Value	Remarks
IP address	Example: 192.168.21.128	IP address for the PC
Subnet mask	Example: 255.255.255.0	Set the same value as the subnet mask that was specified for the DL750/DL750P.
Gateway	None	
DNS	Disable	
WINS	Disable	

The following procedure describes the steps for Windows 95/98/ME. For Windows NT/2000 Pro/XP, carry out equivalent steps accordingly.

1. Choose **Settings > Control Panel** from the **Start** menu to open the Control Panel folder.
2. Double-click the **Network** icon to display the following network setup dialog box.
3. Select the **TCP/IP** corresponding to the Ethernet NIC that is connected to the PC and click **Properties** to display the TCP/IP properties setup dialog box.

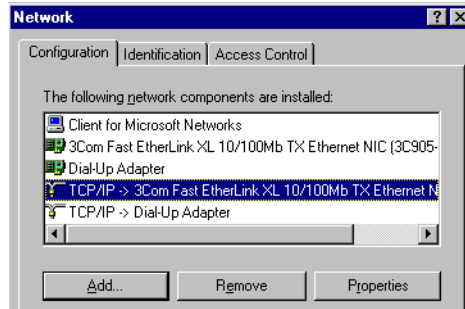

4. Set the parameters such as the IP address according to the table on the previous page and click **OK**.

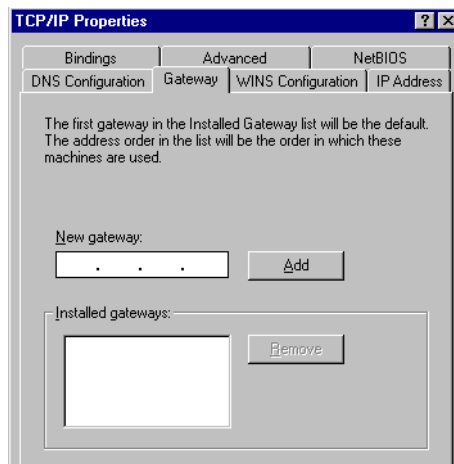
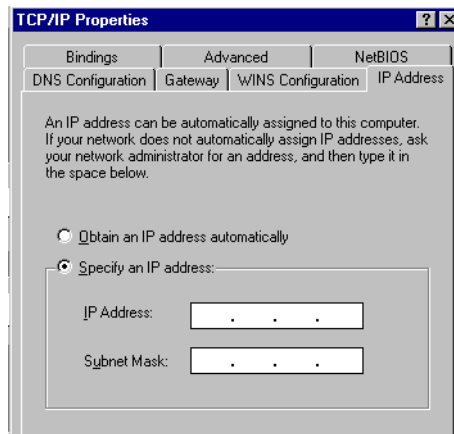

# 16.3 Saving/Loading Data to a Network Drive (FTP Client Function)

<For a description of this function, refer to page 2-59.>

## Procedure

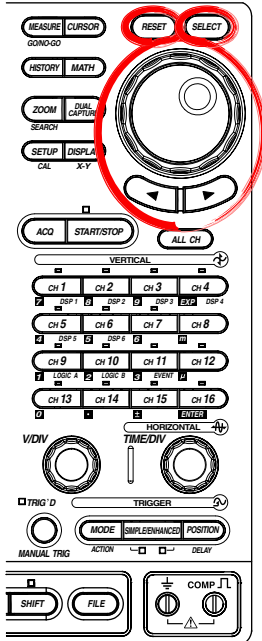
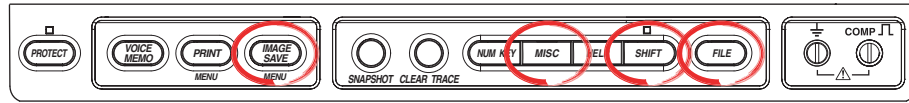

1. Press **MISC**.
2. Press the **Network** soft key.
3. Press the **Net Drive Setup** soft key. The Net Drive setup menu appears.

### Setting the FTP Server

4. Use the **jog shuttle** and **SELECT** to select FTP Server.
5. Enter the IP address of the FTP server according to the procedure given in section 4.2. When using DNS (section 16.2), you can specify the address by name.

### Setting the Login Name and Password

6. Use the **jog shuttle** and **SELECT** to select Login Name.
7. Enter the login name using up to 15 characters according to the procedure given in section 4.2.
8. Use the **jog shuttle** and **SELECT** to select Password.
9. Enter the password corresponding to the login name using up to 15 characters according to the procedure given in section 4.2.

### Setting the Timeout Time

10. Use the **jog shuttle** and **SELECT** to set Time Out. The selectable range is 0 to 3600 (s).

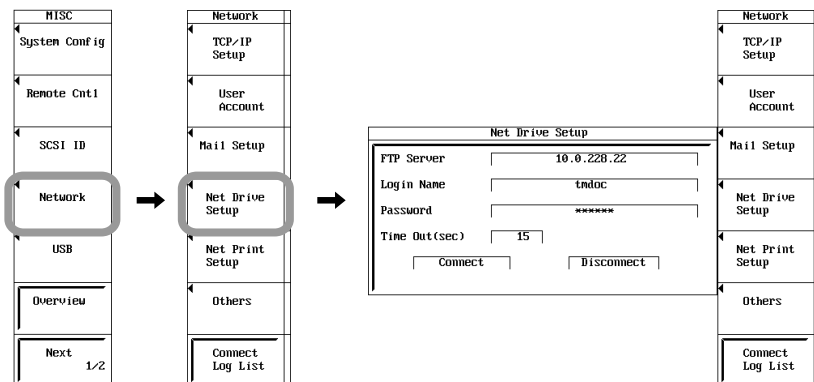

### Note

- For keyboard (soft keyboard) operation, see section 4.2, "Entering Values and Strings."
- If Login Name is set to anonymous, you do not have to enter the password.





**Connecting/Disconnecting to a Network Drive**

11. Use the **jog shuttle** and **SELECT** to select Connect. Connection is made to the network drive. When the connection is established,  is displayed at the upper right corner of the screen.  
Use the **jog shuttle** to move the cursor to Disconnect, then press **SELECT** to close the connection. The  displayed at the upper right corner of the screen disappears.

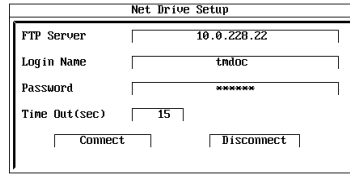

**Saving/Loading the Screen Image, Waveform, and Setup Data**

• **Saving/Loading the screen image data**

12. Press **SHIFT+IMAGE SAVE**.
13. Press the **File List** soft key. The File List window appears.
14. Use the **jog shuttle** to select [Network] in the File List window.

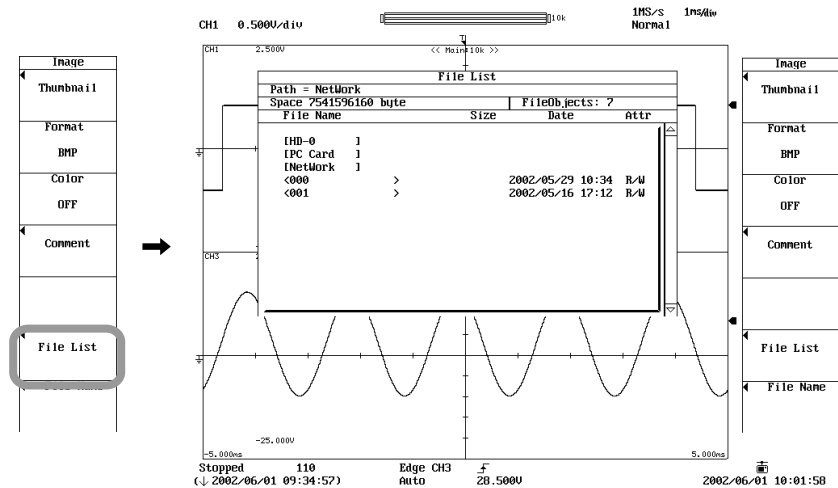

15. The succeeding procedure is the same as the procedure described in section 13.11, "Saving Screen Image Data" and section 13.12, "Displaying Thumbnails of the Saved Screen Image Data." To save screen image data by attaching a comment, see section 13.19, "Using the Voice Comment Function."

### 16.3 Saving/Loading Screen Images, Waveforms, and Setup Data to a Network Drive (FTP Client Function)

- **Saving/Loading Waveform Data and Setup Data**

12. Press **FILE**.
13. Press the **Utility** soft key. The File List window appears.
14. Use the **jog shuttle** to select [Network] in the File List window.

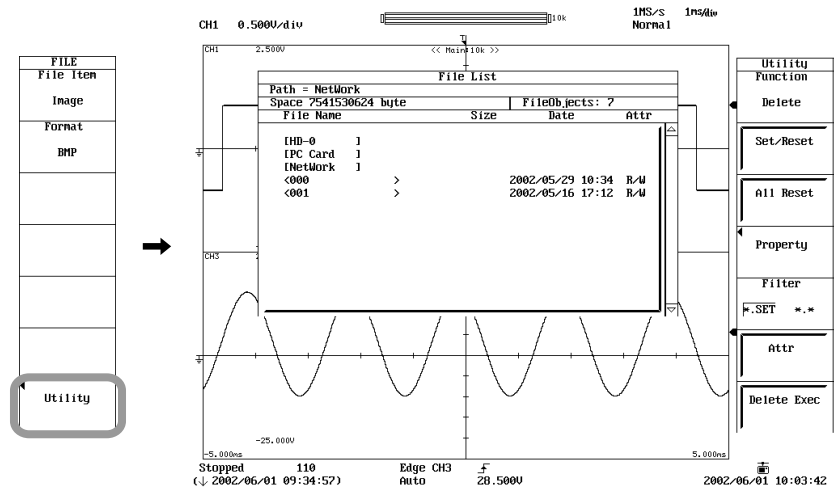

15. The succeeding procedure is the same as the procedure described in section 13.8, "Saving/Loading the Setup Data" and section 13.7, "Saving/Loading the Waveform Data." In addition, waveform data with a voice memo attached can be saved/loaded. For details, see section 7.9, "Using the Voice Memo Function."

### Note

- An FTP server software must be running on the PC or workstation to which the DL750/DL750P is to be connected. In addition, the following points need attention regarding the server program settings.
- Set the list output (string returned by the dir command) to UNIX format.
- Set the home directory and its subdirectories to allow writing.
- The client cannot move above the home directory.
- The newest file is not necessarily displayed at the top of the file list.
- Files and directories that are longer than 17 characters cannot be accessed.
- Depending on the server, "<..>" that indicates a higher directory may not be displayed.
- The time information in the file list will not be displayed correctly for the following cases.
  - On Windows NT when the time stamp is displayed using am and pm.
  - Servers that return characters other than ASCII characters in the list
- The following operations are not possible.
  - Turning file protect ON and OFF on saved files.
  - Formatting a network drive.
  - Copying between network drives.
  - Renaming a file on the network.
- This function cannot be used when using the FTP server function or the Web server function.
- To use this function, you must configure TCP/IP according to the procedure given in section 16.2.
- To apply new settings that are made while connected to a network drive, drop the connection using Disconnect and reconnect.
- If you are disconnected by the server when using the FTP client, you will be automatically reconnected if you perform a file operation. This also hold true, if the network drive is selected for Save to File when using an action trigger or GO/NO-GO.

### Explanation

You can save the screen image data, waveform data, and setup data to network drives via the Ethernet network in the same fashion as with the floppy disk drive, Zip disk drive, and PC card drive.

If you wish to make the DL750/DL750P the FTP server and access the DL750/DL750P from an FTP client on the network, see section 16.6.

#### FTP Server

Enter the IP address of the FTP server (the PC or workstation running the FTP server) on the network to which waveform and setup data will be saved. On networks supporting DNS, you can specify the host and domain by name instead of the IP address.

#### Login Name

Enter the login name using up to 15 characters. The default setting is "anonymous." The characters that can be used are all the ASCII characters on the keyboard.

#### Password

Enter the password corresponding to the login name using up to 15 characters. The characters that can be used are all the ASCII characters on the keyboard.

#### Time Out

When an FTP server is accessed from the DL750/DL750P and data is not transmitted for a certain period of time (timeout time), the DL750/DL750P decides that the transmission to the FTP server is not possible and closes the connection. You can set the timeout value in the range of 0 to 3600 s. The default setting is 15 s.

# 16.4 Setting up the Network Printer

<For a description of this function, refer to page 2-59.>

## Procedure

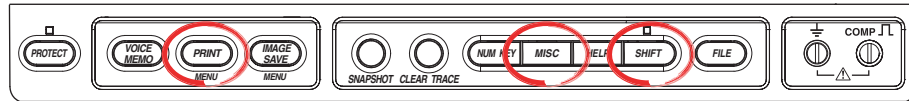

1. Press **MISC**.
2. Press the **Network** soft key.
3. Press the **Net Print Setup** soft key. The Net Print setup menu appears.

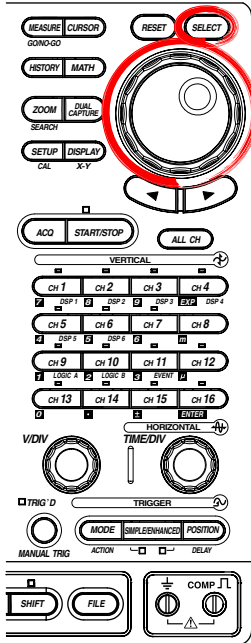

### Setting the LPR Server

4. Use the **jog shuttle** and **SELECT** to select LPR Server.
5. Enter the IP address of the printer server according to the procedure given in section 4.2. If you are using DNS, you can specify the printer server by name.

### Setting the Printer Name

6. Use the **jog shuttle** and **SELECT** to select LPR Name.
7. Enter the printer name according to the procedure given in section 4.2.

### Note

For keyboard (soft keyboard) operation, see section 4.2, "Entering Values and Strings."

### Printing the Screen Image Data

8. Print the screen image data according to the procedure given in section 12.4, "Printing the Screen Image Data on a Network Printer."

### Note

- To use this function, configure the TCP/IP settings beforehand according to section 16.2, "Setting up the TCP/IP."
- Output is possible to printers or printer servers that support the TCP/IP protocol.
- This function cannot be used when using the FTP server function or the Web server function, or when performing file operations.

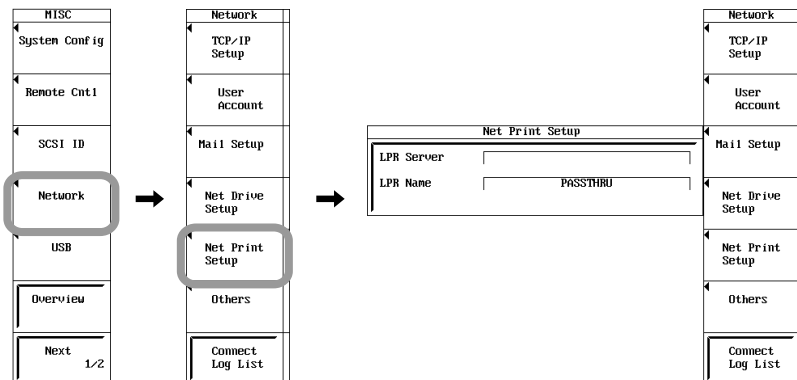

**Explanation**

As with the built-in printer, you can print the screen image data on a network printer via the Ethernet network.

**Setting the Network Printer: Net Print Setup****• LPR Server**

Specify the IP address of the network printer server. On networks supporting DNS, you can specify the host and domain by name instead of the IP address.

**• Printer Name: LPR Name**

Specify the name of the printer on which screen image data will be printed.

**Selecting the Output Format**

The following six printer formats are supported.

- ESC-P
- ESC-P2
- LIPS3
- PCL5
- BJ
- PostScript

# 16.5 Sending Periodic Mail or Action Mail (SMTP Client Function)

<For a description of this function, refer to page 2-60.>

## Procedure

### Sending Periodic E-mail Messages

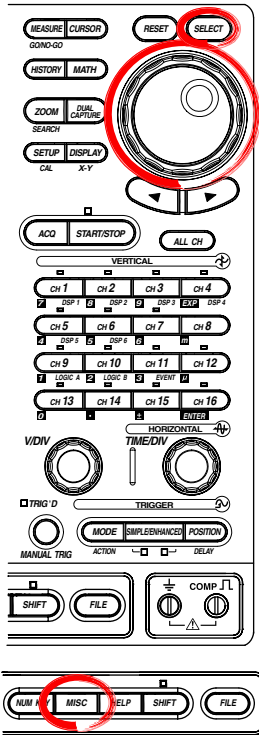

1. Press **MISC**.
2. Press the **Network** soft key.
3. Press the **Mail Setup** soft key. The Mail setup menu appears.

### Setting the Mail Server

4. Use the **jog shuttle** and **SELECT** to select Mail Server.
5. Enter the IP address of the mail server according to the procedure given in section 4.2. If you are using DNS, you can specify the mail server by name.

### Setting the Recipient Mail Address

6. Use the **jog shuttle** and **SELECT** to select Mail Address.
7. Enter the recipient mail address using up to 40 characters according to the procedure given in section 4.2.

### Setting a Comment

8. Use the **jog shuttle** and **SELECT** to select Comment.
9. As necessary, enter the comment using up to 30 characters according to the procedure given in section 4.2.

### Setting the Time When the Mail Is to Be Sent

10. Use the **jog shuttle** and **SELECT** to select the hour, minute, or second of MailBaseTime
11. Enter the time when mail is to be sent according to the procedure given in section 4.2.

### Setting the Attached Image File

12. Use the **jog shuttle** and **SELECT** to select ON (attach image file) or OFF (do not attach image file).

### Setting the Interval for Sending Mail

13. Use the **jog shuttle** and **SELECT** to select Interval.
14. Select the interval for sending mail in the range of 1 h to 24 h according to the procedure given in section 4.2.

### Sending a Test Mail

15. Turn the **jog shuttle** to move the cursor to Mail Test.  
To send a test mail to the specified recipient, press **SELECT**.  
While mail transmission is in progress, is indicated at the upper left corner of the screen.

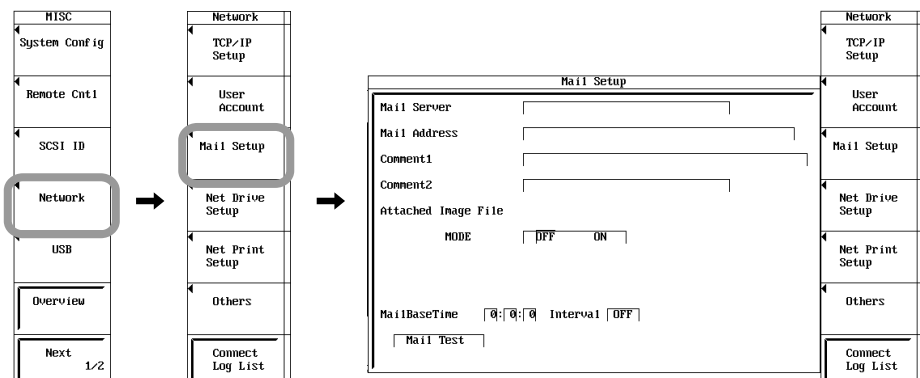

**Note**

- For keyboard (soft keyboard) operation, see section 4.2, “Entering Values and Strings.”
- The sender (From) address of the e-mail messages sent by the DL750/DL750P is the same as the specified recipient address.
- If the transmitted contents indicate error logs, the most recent error is at the top of the error log.
- To use this function, configure the TCP/IP settings beforehand according to section 16.2, “Setting up the TCP/IP.”
- If you set Interval to OFF, periodic mail is not sent.

**Sending Action E-mail Messages**

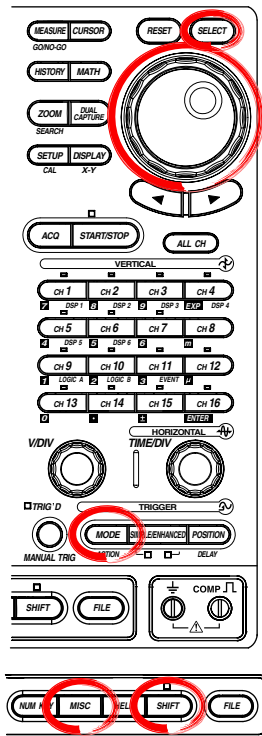

1. Set items according to steps 1 to 9 in “Sending Periodic E-mail Messages.” You do not have to set MailBaseTime and Interval for action mail. If you wish to use only action mail, set Interval to OFF.

**Setting the Action**

• **From the ACTION Menu**

2. Press **SHIFT+MODE**.
3. Press the **Mode** soft key to select **ON Trigger**.
4. Press the **Action** soft key. The action setup menu appears.
5. Use the **jog shuttle** and **SELECT** to set Send Mail to ON.
6. Use the **jog shuttle** and **SELECT** to set Mail Count (the number of mail messages).
7. Press **START/STOP** to start the waveform acquisition. A mail is sent to the specified address each time a trigger occurs. While mail transmission is in progress, is indicated at the upper left corner of the screen.

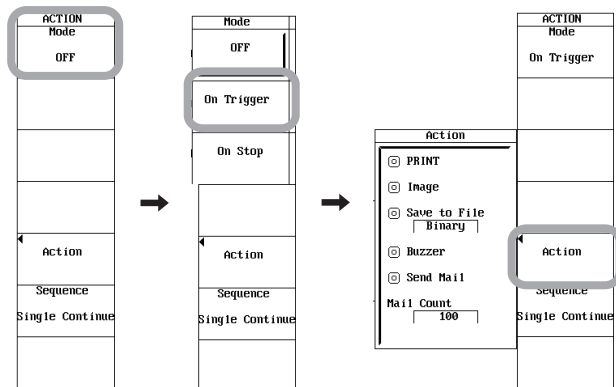

## 16.5 Sending E-mail Messages (Periodic Mail or Action Mail)

- **From the GO/NO-GO Menu**
  2. Press **SHIFT+MEASURE**.
  3. Press the **Mode** soft key. The Mode selection menu appears.
  4. Press the **Zone** or **Parameter** soft key.
  5. Set GO/NO-GO items according to the procedure in section 11.8 and 11.9.
  6. Press the **Action** soft key. The action setup menu appears.
  7. Use the **jog shuttle** and **SELECT** to set Send Mail to ON.
  8. Use the **jog shuttle** and **SELECT** to set Mail Count (the number of mail messages).
  9. Press the **Exec** soft key to start the GO/NO-GO operation. When a specified condition occurs, a mail is sent to the specified address.  
While mail transmission is in progress, ☒≈ is indicated at the upper left corner of the screen.

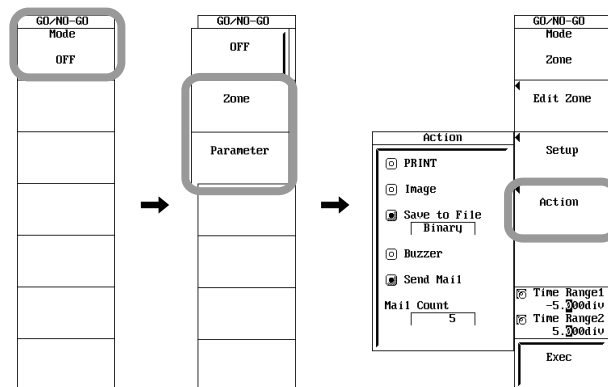

### Note

- The mail recipient is the address specified in "Mail Address" of "Network"/"Mail Setup" in the MISC menu.
- The sender (From) address of the e-mail messages sent by the DL750/DL750P is the same as the specified recipient address.
- Periodic mail and action mail can be used together. To use only action mail, set Interval to OFF.
- To use this function, configure the TCP/IP settings beforehand according to section 16.2, "Setting up the TCP/IP."



**Explanation****Mail Server**

Specify the IP address of the network mail server. On networks supporting DNS, you can specify the host and domain by name instead of the IP address.

**Mail Address**

Enter the recipient address using up to 40 characters.

**Comment**

The comment is written on the first line of the transmitted mail. Enter it as necessary. Enter comment using up to 30 characters.

**Transmission Time: MailBaseTime**

The time when mail transmission is to start can be set in units of hour, minute, and second, in the following range.

0:0:0 to 23:59:59

**Attaching Image Data (Attached Image File, Version 4.01 or Later)**

The screen image shown at the time of mail transmission can be attached to the mail. The data format of the screen image data is the format specified in section 13.11, "Saving Screen Image Data."

The file name differs between periodic mail and action mail.

File name of periodic mail: DL\_image.png

File name of action mail: DL\_nnnn.png (where nnnn is an automatically assigned number in the range of 0001 to 1000)

**Transmission Interval**

The following mail transmission intervals are available.

OFF, 1 H, 2 H, 3 H, 4 H, 6 H, 8 H, 12 H, and 24 H

However, if you select OFF, periodic mails cannot be transmitted.

**Sending a Test Mail: Mail Test**

A test mail is sent to the address specified by Mail Address.

### **Periodic Mail**

The DL750/DL750P status can be sent periodically to a specified mail address on the network.

- **DL750/DL750P Information That Is Transmitted**
  - **Acquisition Condition**  
Start/Stop, trigger condition, and acquisition counter
  - **Error Log Information**  
Error number and corrective action in English (up to 16 errors)
  - **Success/Fail Information of GO/NO-GO**  
Only when GO/NO-GO determination is executed (see sections 11.8 and 11.9)
  - **Results of Waveform Parameter Measurement**  
Only when automated measurement of waveform parameters (see section 11.6) or GO/NO-GO determination using waveform parameters (see section 11.8) is executed.  
The maximum number of measurement results of waveform parameters that are sent is the same as the maximum number (24) of measurement results displayed on the DL750/DL750P.

- **Sample Periodic Mail**

[Comment] aaaaaa

[ACQ Status] Stopped 162

[GO/NOGO Status] Success: 140 Fail: 21

Max (C1) 4.16667V

SDv (C2) 697.941mV

Freq(C3) 500.0000kHz

+Wd (C4) 1.00us>

ErrNo 004 Exit from GO/NO-GO mode.

ErrNo 806 Cannot change settings during GO/NO-GO.

Stop the GO/NO-GO.

ErrNo 004 Exit from GO/NO-GO mode.

ErrNo 806 Cannot change settings during GO/NO-GO.

Stop the GO/NO-GO.

ErrNo 602 No SCSI device or no media inserted.

Check the SCSI device connection and

the SCSI ID, and make sure that the storage

medium is inserted (if applicable).

**Action Mail**

Information such as the trigger time can be sent to a specified mail address on the network as an action of action-on-trigger or GO/NO-GO determination.

- **DL750/DL750P Information That Is Transmitted**

- **Acquisition Condition**

- Start/Stop, acquisition counter

- **Trigger Time**

- **Success/Fail Information of GO/NO-GO**

- Only when GO/NO-GO determination is executed (see sections 11.8 and 11.9).

- **Results of Waveform Parameter Measurement**

- Only when automated measurement of waveform parameters (see section 11.6) or GO/NO-GO determination using waveform parameters (see section 11.8) is executed.

- **Fail Cause**

- Only when GO/NO-GO determination is executed (see sections 11.8 and 11.9).

- **Sample Action Mail**

[Comment] aaaaaa

[ACQ Status] Stopped 1

[Trigger Date and Time] 2002/06/17 17:28:59.38

[GO/NOGO Status] Success: 9 Fail: 1

[NOGO Factor] Param4(Ch4,tWd )

Max (C1) 4.16667V

SDv (C2) 697.941mV

Freq(C3) 500.0000kHz

+Wd (C4) 1.00us>

# 16.6 Accessing the DL750/DL750P from a PC or Workstation (FTP Server Function)

<For a description of this function, refer to page 2-60.>

## Procedure

This section describes the FTP server function when a general FTP client software (such as WS\_FTP or FFFTP) is used. To use FTP through the Web browser, see section 16.7.

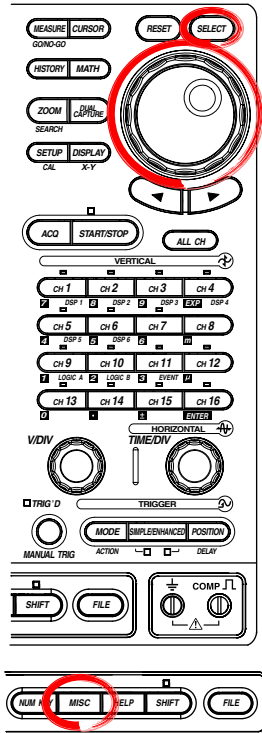

1. Press **MISC**.
2. Press the **Network** soft key.
3. Press the **User Account** soft key. The User Account setup menu appears.

### Setting the User Name

4. Use the **jog shuttle** and **SELECT** to select User Name.
5. Enter the user name according to the procedure given in section 4.2. Specify anonymous if you wish to allow access to all users. To restrict access, enter the user name using up to 15 characters.

### Setting the Password

6. Use the **jog shuttle** and **SELECT** to select Password.
7. Enter the password using up to 15 characters according to the procedure given in section 4.2.

If you select the ENT key on the soft keyboard or press the ENT soft key, the entered password (appears as \*\*\*\*\*) is cleared from the soft keyboard screen. Enter the password again for confirmation. The password (appears as \*\*\*\*\*) is confirmed and displayed in the Password column of the User Account setup menu. If the password entered the second time is different from the first, the entered password is cleared from the soft keyboard screen. If the user name is set to anonymous, you do not have to enter the password.

### Setting the Timeout Time

8. Use the **jog shuttle** and **SELECT** to set Time Out.
- The connection to the network is automatically closed if there is no access to the DL750/DL750P for the specified time.

### Note

For keyboard (soft keyboard) operation, see section 4.2, "Entering Values and Strings."

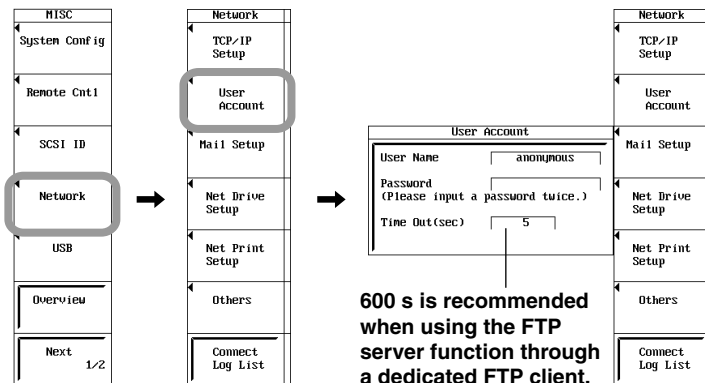

---

## 16.6 Accessing the DL750/DL750P from a PC or Workstation (FTP Server Function)

### Executing the FTP Client Software

9. Execute an FTP client software on the PC or workstation. Perform file operations using the user name specified in steps 4 and 5.

### Displaying the Connection Log List

10. Press the **Connect Log List** soft key. The data and time, user name, and IP address of the 25 recent accesses are displayed.

### **Note**

---

- The log list is cleared when the power is turned OFF.
  - The DL750/DL750P supports two clients, but file operations cannot be performed simultaneously.
  - When the DL750/DL750P is being accessed from a PC or workstation (logged in),  is displayed in the lower right part of the screen.
  - This function cannot be used when using the FTP client function, network printer function, or the Web server function, or when performing file operations.
  - To use this function, configure the TCP/IP settings beforehand according to section 16.2, "Setting the TCP/IP."
  - To apply new settings, the DL750/DL750P must be power cycled.
  - The files that can be uploaded to the DL750/DL750P are those with the following extensions.  
.WVF, .HDR, and .SET  
However, do not upload files to the realtime recording area.
-

## 16.6 Accessing the DL750/DL750P from a PC or Workstation (FTP Server Function)

---

### **Explanation**

You can access the DL750/DL750P's floppy disk drive, Zip drive, PC card drive, internal hard disk (optional), SCSI device, or USB storage device from a PC or workstation via the Ethernet network.

To access the DL750/DL750P, an FTP client software is needed on the PC or workstation.

For a description of the FTP using the Web browser (Web server function), see section 16.7.

### **User Name**

Enter the user name using up to 15 characters. The default setting is "anonymous." The characters that can be used are all the ASCII characters on the keyboard.

### **Password**

Enter the password using up to 15 characters. The characters that can be used are all the ASCII characters on the keyboard.

### **Time Out**

The connection to the network is automatically closed if there is no access to the DL750/DL750P for the specified time.

### **Note**

- It is recommended that the timeout be set to 600 s when using the FTP server function through a dedicated FTP client.
  - When using the FTP server function on a Web browser (see section 16.7), it is recommended that the timeout be set to 5 s (default value).
- 

### **Connect Log List**

The data and time, user name, IP address, access result of the 25 recent accesses from the PC or workstation to the DL750/DL750P are displayed.

## 16.7 Using the Web Server Function

<For a description of this function, refer to page 2-60.>

You can use the Web server function on the DL750/DL750P to display the screen image of the DL750/DL750P on the Web browser window on your PC and perform file operations on the DL750/DL750P using the keys displayed on the Web browser window.

This section contains the following information.

- Overview of the Web Server Function -> See this page.
- Operating Environment
  - PC Environment -> See page 16-24.
  - DL750/DL750P Environment -> See page 16-25.
- Preparations for Using the Web Server Function
  - Preparations on the DL750/DL750P -> See page 16-26.
  - Preparations on the PC -> See page 16-27.
- Using the Web Server Function
  - Using the FTP Server Function -> See 16-31.
  - Performing Data Capture -> See page 16-32.
  - Displaying the Measurement Trend of Waveform Parameters -> See page 16-38.
  - Using Control Scripts -> See page 16-42.
  - Showing the Log -> See page 16-44.
  - Showing the Instrument Information -> See page 16-46.
  - Viewing the Link Destination -> See page 16-47.

### Overview of the Web Server Function

- **FTP Server Function (On the Web Browser)**

View the list of files stored on the storage media of the DL750/DL750P (internal hard disk or built-in storage medium) and transfer files to the PC.
- **Data Capture**

The following operations can be carried out.

  - Change the display format of the DL750/DL750P and display data that is acquired in the history memory.
  - Display the screen image of the DL750/DL750P.
  - Save the waveform data and setup data to the PC.
  - Load the setup data stored on the PC into the DL750/DL750P.
- **Measurement Trend of the Waveform Parameter Values**

Using the Excel function, display the trend of the selected waveform parameter values. The statistics of the measured values can also be computed.
- **Control Script**

Control the DL750/DL750P using communication commands (see the *Communication Interface User's Manual* IM701210-18E).
- **Log**

Displays the past log of errors that occurred on the DL750/DL750P, GO/NO-GO determination, and action-on-trigger. Up to the 30 newest incidents are logged.
- **Instrument Information**

Display the model of the DL750/DL750P, the module configuration, the presence/absence of options, the ROM version (firmware version), etc.
- **Link**

View the Web page for the DL750/DL750P.

## System Requirements

### PC Environment

- **PC**  
PC running Microsoft Windows 98 Second Edition, Microsoft Windows NT 4.0, Microsoft Windows Millennium Edition, Microsoft Windows 2000 Professional, or Microsoft Windows XP Professional.
- **OS**  
Microsoft Windows 98 Second Edition, Microsoft Windows NT 4.0, Microsoft Windows Millennium Edition, Microsoft Windows 2000 Professional, or Microsoft Windows XP Professional.
- **Internal Memory**  
64 MB or more recommended.
- **Communication Port**  
Ethernet communication port that supports 10BASE-T or 100BASE-TX. Use this communication port to connect the PC to the network.
- **Display**  
Display supported by the OS indicated above with a resolution of 1024 × 768 dots or higher.
- **Mouse or Pointing Device**  
Mouse or pointing device supported by the OS indicated above.
- **Files Required for the Web Browser**  
Of the Web server functions, the following files are required when using the data capture, measurement trend, or command script function. For the installation procedure on the PC, see “Installing Files Required for the Web Browser” (page 16-28).  
Msvbvm60.dll  
cmdlgjp.dll  
comdlg32.ocx

- **Combinations of OS and Application Software That Have Been Tested**

OS	Web Browser	Spreadsheet Software <sup>1</sup>
Windows NT	Internet Explorer 5.0	Microsoft Excel 97
Windows 98	Internet Explorer 5.0	Microsoft Excel 97
Windows 98 Second Edition	Internet Explorer 5.0	Microsoft Excel 97
Windows 2000 Professional	Internet Explorer 5.0/5.5/6.0	Microsoft Excel 97
Windows Millennium Edition	Internet Explorer 5.5/6.0	Microsoft Excel 97/2000/2002
Windows XP Professional	Internet Explorer 6.0	Microsoft Excel 2002

1. The spreadsheet software is required when displaying the trend of waveform parameters of the Web server function.



**DL750/DL750P Environment**

- **Connection to the Network**

Connect the DL750/DL750P to the network using the Ethernet. For the connection procedure, see section 16.1.

- **TCP/IP**

Configure the network environment and IP address for communication using the Ethernet interface. For the procedure, see section 16.2.

- **Communication Interface**

Set the communication interface to Network. For the procedure, see “Setting the Communication Interface to the Network” (page 16-26).

- **User Account**

Set the user account used to access the DL750/DL750P from the PC. For the procedure, see section 16.6.

- **Time Difference from the Greenwich Mean Time**

When using the Web server function, set the time difference from the GMT. Normally, the time difference is also set on the PC. Setting the time difference correctly allows the DL750/DL750P and the PC to detect the local time correctly. Consequently, the PC will be able to detect whether a file is new when transferring or saving the file. For the procedure, see section 16.8.

**Note**

- Use Internet Explorer version 5.0 or later for the Web browser.
- The Web server function contains software programs that have not been authenticated. Therefore, the following dialog box may appear. In such case, click Yes and install the software.

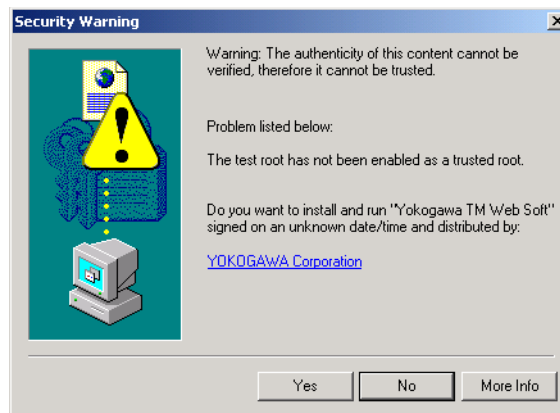

- You cannot open multiple Internet Explorer windows on the same PC and use the same function of the Web server function simultaneously.
- When using the storage function of the FTP server function (on the Web browser), data capture function, or the log display on the same PC, other Web server functions cannot be used.
- When using the storage function of the FTP server function (on the Web browser), data capture function, or the log display on a PC, other PCs cannot use the Web server function.
- The Web server functions use the Ethernet interface for communication. If the Ethernet interface is configured for controlling the DL750/DL750P using a communication command (see the *Communication Interface User's Manual* IM701210-18E), the Ethernet interface cannot be used simultaneously.
- The Web server function cannot be used while the DL750/DL750P is printing, operating files (file operation from the front panel key or file transfer using the FTP server function), realtime recording, or while the Windows network drive is being used.
- When the DL750/DL750P is registered as a network drive (see section 16.3), the Web server function cannot be used.

**Preparations for Using the Web Server Function**

**Connecting the PC and the DL750/DL750P to the Network**

Connect the PC and the DL750/DL750P to the network. For the connection procedure, see section 16.1.

**Preparations on the DL750/DL750P**

• **Setting the Communication Interface to Network**

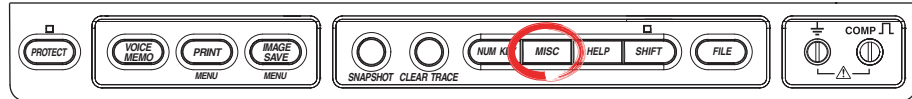

Turn ON the power to the DL750/DL750P. After the DL750/DL750P boots up normally, carry out the following procedure.

1. Press **MISC**. The MISC menu appears.
2. Press the **Remote Cntl** soft key. The Remote Cntl menu appears.
3. Press the **Device** soft key. The Device menu appears.
4. Press the **Network** soft key. The Ethernet interface is selected for the communication means.

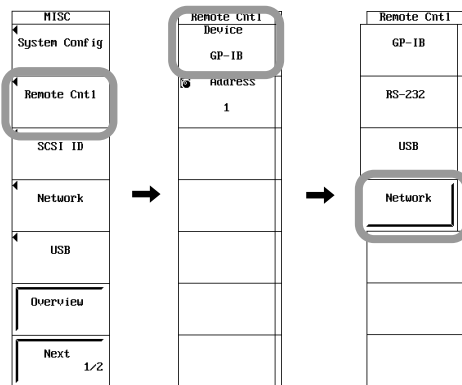

• **Setting up the TCP/IP**

5. Set the TCP/IP on the PC and the DL750/DL750P. For the procedure on the DL750/DL750P, see section 16.2.

• **Setting the User Account Used to Access the DL750/DL750P**

6. Set the user account used to access the DL750/DL750P from the PC. For the procedure, see section 16.6.

**Note**

The User Account in the menu that appears after step 4 is the user account that is used to control the DL750/DL750P through communication commands via the Ethernet network. It is not the user account for using the Web server function.

• **Setting the Time Difference from GMT (Greenwich Mean Time)**

7. Set the time difference between the location where the DL750/DL750P is located and the GMT. For the procedure, see section 16.8.

• **Rebooting**

8. To activate the TCP/IP, user account, and time difference settings, turn OFF the power switch. After a few seconds, turn ON the power switch and boot the DL750/DL750P.



- **Installing Files Required for the Web Server**

- **Using the DL750/DL750P and the PC While Connected to the Internet**

When you use the Web server function for the first time, the files required for the Web browser are installed automatically from the Microsoft Web site.

If the three files (`Msvbvm60.dll`, `cmdlgjp.dll`, and `cmdlg32.ocx`) are already installed in the PC when using the Web server function for the first time, step 7 is no required.

7. When the data capture, measurement trend, or command script function of the Web server function is used for the first time, three files, `Msvbvm60.dll`, `cmdlgjp.dll`, and `cmdlg32.ocx`, are automatically downloaded from the Microsoft Web site and installed in the PC. At this point, a dialog box for confirming the installation appears. Click **Yes**.  
(You may need to restart the PC during the installation.)

After the installation completes successfully, proceed to step 9 on the next page.



or

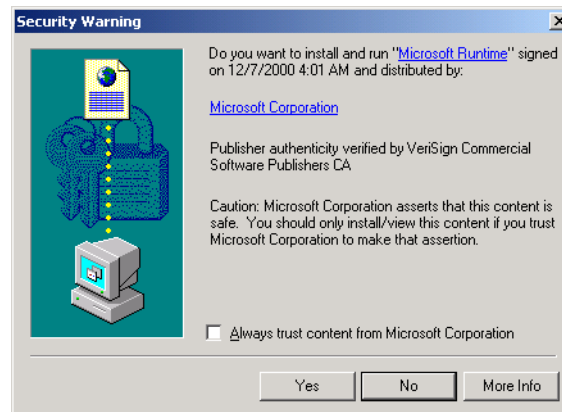

- **Using the DL750/DL750P without Connecting to the Internet**

If the three files, `Msvbvm60.dll`, `cmdlgjp.dll`, and `comdlg32.ocx`, are not installed in the PC when using the Web server function for the first time, install the files beforehand according to the following procedure.

7. Download the following file from the YOKOGAWA Web site (<http://www.yokogawa.com/tm/Bu/DLsoft/web.htm>).  
**YOKOGAWA T&M Web Runtime: ytmwrun.exe**  
**Data size: Approx. 1.5 MB**
8. Double-click `ytmwrun.exe` that you have downloaded. The installation of the aforementioned three files starts. Follow the instructions to install the files.

- **Checking the Web Browser (Internet Explorer) Security Settings**

Check the security settings on the Internet Explorer. The settings indicated in the table on the next page are defaults. If the settings on your browser do not match, set them back to the settings in the table on the next page. Otherwise, the Web server function cannot be used.

The following explanation is for Internet Explorer 5.5. For other versions, carry out equivalent steps accordingly.

9. Choose **Internet Options** from the **Tools** menu. The Internet Options dialog box opens.
10. Click the **Security** tab.
11. Select a Web content zone.

The Web service zone varies depending on the network environment and browser settings. Check with your network administrator to select the zone.

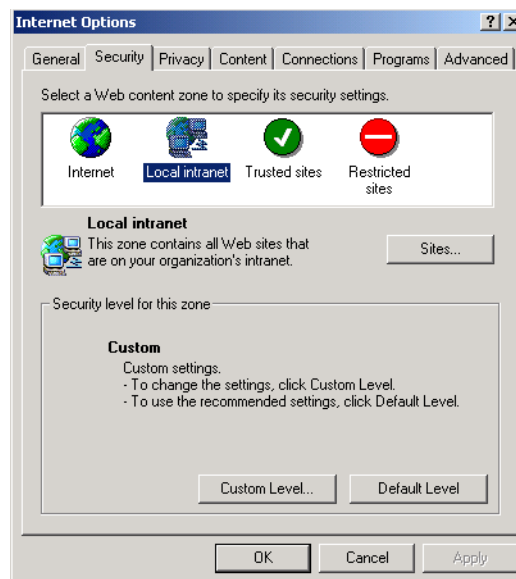

## 16.7 Using the Web Server Function

- Click **Custom Level**. The Security Settings dialog box opens.

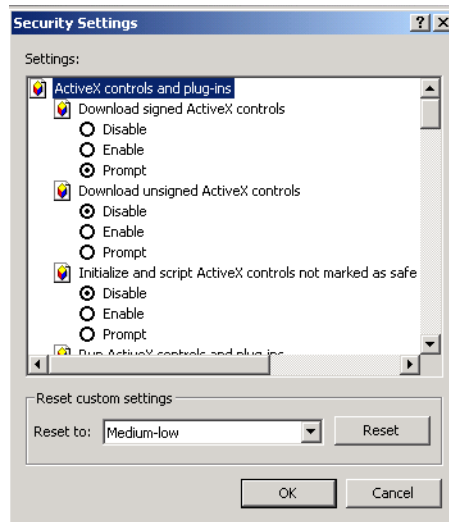

- Set the security settings as shown in the following table.

Item	Security Level
Run ActiveX controls and plug-ins	Enable
Script ActiveX controls marked safe for scripting	Enable
Download signed ActiveX controls	Prompt

- Click **OK**.

## Using the Web Server Function

### Using the FTP Server Function (On the Web Browser)

Before using this function, check that the communication interface of the DL750/DL750P is set to Network (see page 16-26).

Click the **FTP** icon on the Web server window. A window for viewing the storage media of the DL750/DL750P (storage media view window) appears.

The storage media view window may not appear. In this case, click the Refresh button on the Web browser. A login dialog box opens. Log in. The storage media view window appears.

#### Web Server Window

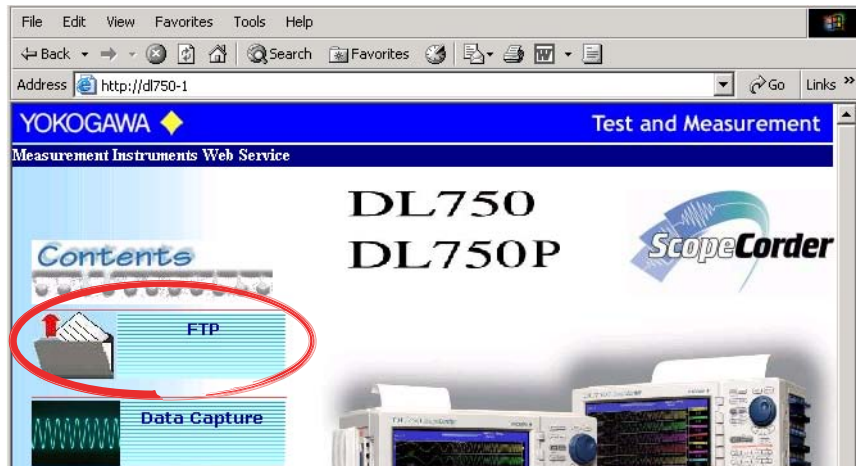

#### Storage Media View Window

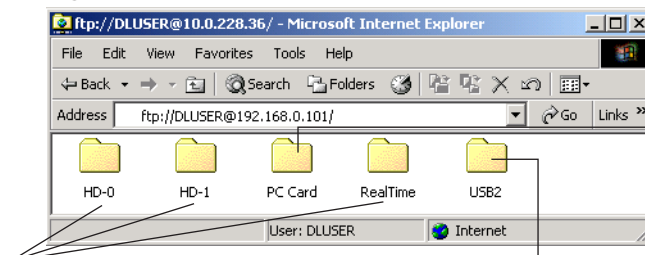

Built-in storage media  
Depending on the product  
specifications, one of the  
following is displayed.

- Fd: Floppy disk
- Zip: Zip disk
- PC Card: PC card

#### Internal hard disk

- Real Time: Area used by realtime recording
- HD0, HD1:  
Storage area for waveform and setup data  
(the number of displayed items varies  
depending on the number of partitions)

USB storage device

- You can open folders on each storage medium and view the file list.
- You can select files displayed on the window and transfer files to the PC.

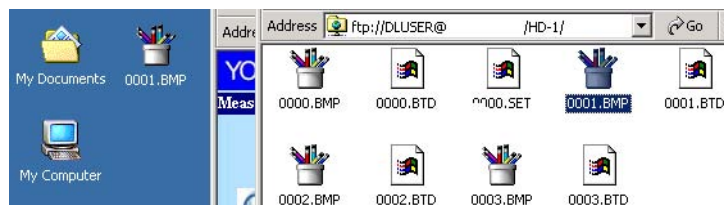

---

**CAUTION**

- Never change the contents on the DL750/DL750P disk from the PC (read only). Writing to the disk may destroy files.
- Never perform the following operations. The internal hard disk of the DL750/DL750P will become inaccessible.
  - Delete files on the internal hard disk of the DL750/DL750P from the PC.
  - Add files to the internal hard disk of the DL750/DL750P from the PC.

---

**Note**

- Up to two PCs can log into the file transfer function simultaneously.
- You cannot operate the files simultaneously from two PCs.
- When the DL750/DL750P is printing, operating files (file operation from the front panel key or file transfer using the FTP server function), or realtime recording, the Web server function cannot be used.
- To use the FTP server on a Web browser, a network user account on the DL750/DL750P must be configured. For the procedure of setting user accounts, see steps 1 to 8 in section 16.6.
- An authentication login dialog box may appear on the Web browser, when the FTP icon on the Web server window is clicked. In such case, enter the user name and password that were entered in section 16.6.

---

**Capturing Data**

Before using this function, check that the communication interface of the DL750/DL750P is set to Network (see page 16-26).

Click the **Data Capture** icon on the Web server window. The Data Capture window showing the screen image of the DL750/DL750P and the control panel that allows data saving and loading appears

**Web Server Window**

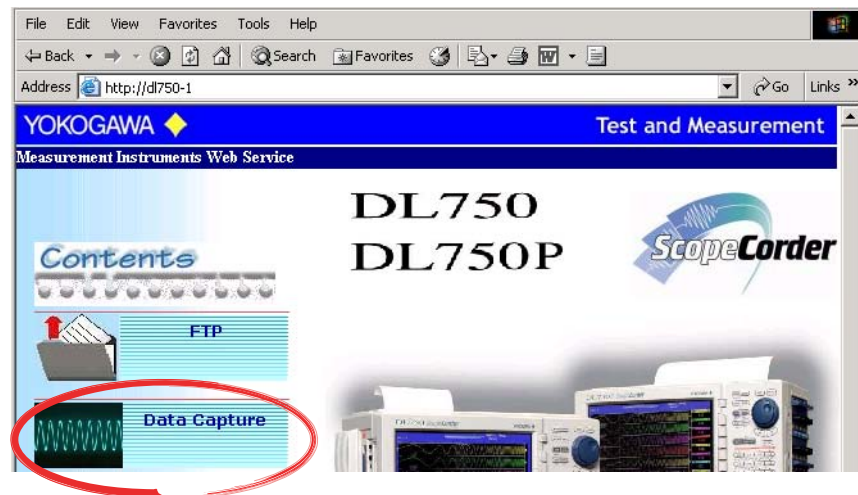



Data Capture Window

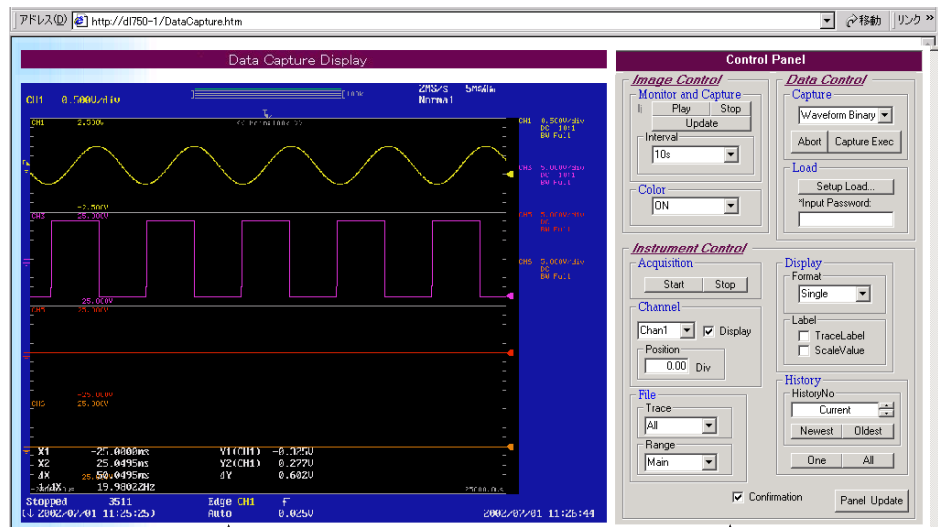

DL750/DL750P screen image

Control panel

• Displaying and Saving the Screen Image (Image Control)

The screen image of the DL750/DL750P can be displayed on the PC screen and saved.

Updating the Screen Image (Monitor & Capture)

Play

Click **Play** to illuminate the update indicator in green and start the updating of the screen image at the specified display update interval (see below).

Stop

Click **Stop** to turn off the update indicator and stop the updating of the screen image.

Update

The screen image is updated when you click Update.

Interval

Set the display update interval to 10 s, 30 s, or 60 s.

Update indicator

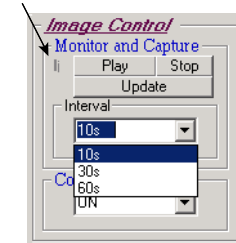

Selecting the Display Color of the Screen Image (Color)

Select the display color from ON, OFF, Reverse, and Gray. For a description of the displayed information for each setting, see the explanation in section 13.11.

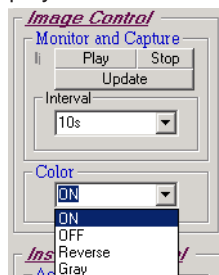

Note

The time it takes to display the screen image on the PC varies depending on the color setting. In decreasing order, the color settings are ON, Reverse, Gray, and OFF.

**Saving the Screen Image in the PC**

Right-click on the screen image that is displayed. A shortcut menu appears as shown in the following figure. Choose **Save Picture As** to save the current screen image.

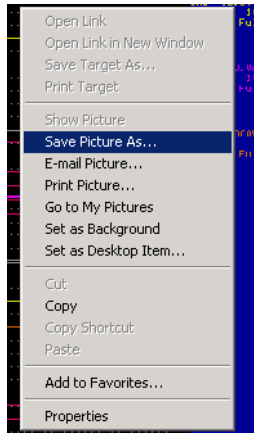

- **Saving Data in the PC and Loading Setup Data from the PC into the DL750/DL750P (Data Control)**

**Saving Data in the PC (Capture)**

**Data Type**

Select the type of data to be saved from Waveform Binary, Waveform ASCII, Waveform Float, Setup, and Measure. For details on the settings, see the explanations in section 13.7, 13.8, and 13.10.

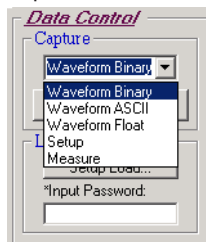

**Capture Exec**

Using the dialog box that appears when you click Capture Exec, set the save destination and file name and save the data.



**Abort**

To abort the save operation while data is being saved, click Cancel on the dialog box. Then, click Abort on the Control Panel.

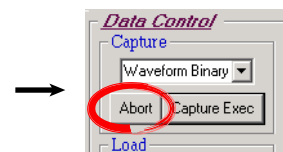
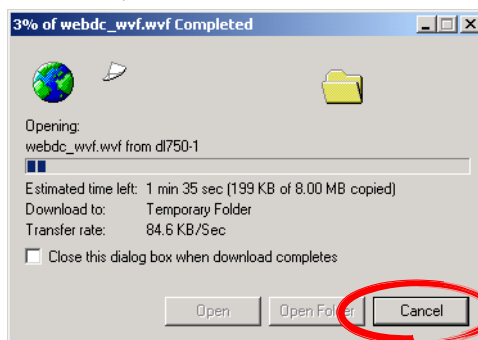

**You must enter a password to abort. For details, see "Input Password" in the next section.**

### Loading the Setup Data from the PC into the DL750/DL750P (Load)

#### Input Password

Enter the password (see page 16-27) that you used to log into the Web server (DL750/DL750P). If the user name of the user account is set to “anonymous” (default setting), the password is not required.

#### Setup Load

Click Setup Load to display the Open dialog box. Select the setup data file you wish to load and click OK to execute the load operation.

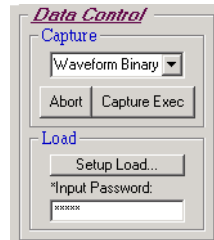

#### Note

- Depending on the operation condition of the DL750/DL750P (such as when measurement is in progress), data save and setup data load operations may not be possible.
- When data is being saved or the setup data is being loaded, other Web server functions cannot be used.
- When loading the setup data or when aborting the save operation, a temporary file (zzzftpzztmpzz.bat) is created in the start directory of the Internet Explorer. After the operation is complete, the temporary file will be deleted.
- If you execute the data save operation when there is no waveform data or waveform parameter, an error is displayed on the DL750/DL750P screen, and a 0-byte file is saved.

#### • Controlling the DL750/DL750P (Instrument Control)

You can use the PC to set the display format and the data save conditions of the DL750/DL750P. The settings entered here apply to the display format and save conditions used to save the data on the previous page

#### Starting/Stopping the Waveform Acquisition (Acquisition)

##### Start

Click **Start** to start the waveform acquisition.

##### Stop

Click **Stop** to stop the waveform acquisition.

#### Turning ON/OFF the Waveform Display and Setting the Vertical Position (Channel)

##### Selecting the Target Waveform

From the channel box, select the channel for turning ON/OFF the display and setting the vertical position from the following:

Chan1 to Chan16 (channels 1 to 16), DSP1 to DSP6 (optional)

##### Display ON/OFF

To display the waveform of the selected channel (turn it ON), select the Display check box. Clear the check box to not display the waveform of the selected channel (OFF).

##### Vertical Position

You can set the vertical position of the waveform of the selected channel. For a description of the selectable range of the vertical position, see section 5.4.

### Setting the Display Format (Display)

#### Display Format

Select the number of divided windows when displaying waveforms from the following:

Single, Dual, Triad, Quad, Octal, and Hexadecimal

For the meanings of the selections, see the explanation in section 8.1.

#### Turning ON/OFF the Display of the Waveform Labels and Scale Values (Label)

- Display Waveform Label (TraceLabel)  
To display the labels of the displayed waveforms, select the TraceLabel check box. Clear the check box to not display the labels.
- Turning ON/OFF the Display of the Upper and Lower Limits of the Displayed Waveforms (ScaleValue)  
To display the upper and lower limits of the displayed waveforms, select the ScaleValue check box. Clear the check box to not display the upper and lower limits.

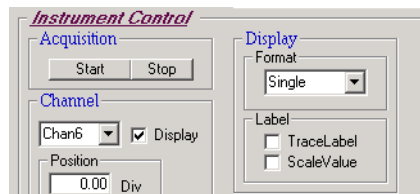

### Selecting the Waveforms to Be Saved (File)

#### Selecting the Target Waveforms (Trace)

From the Trace box, select the waveforms to be saved from the following:

All (all waveforms), 1 to 16 (channels 1 to 16), DSP1 to DSP6 (optional), Math 1 to Math 8 (computed waveforms), PodA to PodB (logic waveforms), and Event (event waveform).

#### Selecting the Save Area (Range)

Select the area in which the target waveform to be saved is displayed from the following:

Main, Z1, and Z2

For the meanings of the selections, see the explanation in section 13.7.

### Setting the History Data Display

#### Selecting by History Data Number (History No.)

You can specify the history number of the data to be displayed.

#### Selecting the Newest or Oldest Data

You can specify the newest or the oldest data in the history data to be displayed.

#### Selecting One or All

- One  
Click **One** to display a single history data point that is selected by the data number or selected by newest or oldest.
- All  
Click **All** to display all the history data.

### Updating the Setup Condition (Panel Update)

Click **Panel Update** to update the control panel settings on the Data Capture window (PC) to match the newest setup condition on the DL750/DL750P.

**Automatically Updating the Screen Image (Confirmation)**

Select the Confirmation check box to automatically update the screen image using the same conditions as Color-OFF when you change the settings of the above items that would cause the screen image to change. Clear the check box to not update automatically.

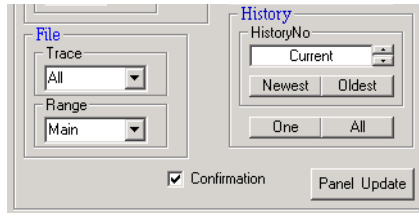
**Note**

- You cannot set the history data display when the DL750/DL750P is making measurements.
- Setting the history data display when there is no history data results in error.
- The timeout time on the PC when controlling the DL750/DL750P is 30 s. Depending on the DL750/DL750P condition, a timeout may occur preventing you from controlling the DL750/DL750P.

## 16.7 Using the Web Server Function

### Displaying the Measurement Trend of the Waveform Parameter Values

Before using this function, check that the communication interface of the DL750/DL750P is set to Network (see page 16-26).

Click the **Measurement Trend** icon on the Web server window. The Measurement Trend window in which the trend display of the waveform parameter values can be set appears.

#### Web Server Window



#### Measurement Trend Window

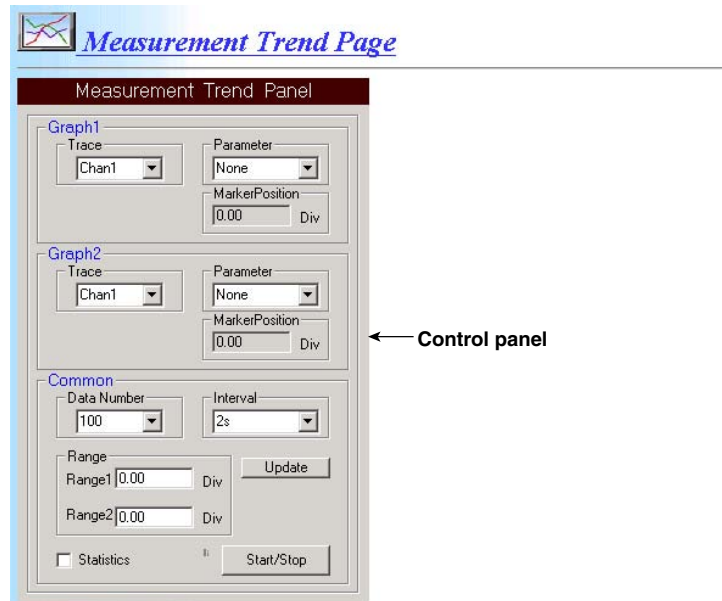

#### Note

- This function retrieves the selected waveform parameter values at the selected retrieve interval from the DL750/DL750P into the PC and displays the trend. To display the retrieved measurement values and trend, Microsoft Excel 97 or later must be installed on the PC.
- Set the time axis setting of the DL750/DL750P to 100 ms/div or less (faster). This function cannot be used on time axis settings that exceed 100 ms/div.
- If the measured value of a waveform parameter is not a normal number (Not A Number), the cell displaying the measured value on Microsoft Excel is set to blank.
- The retrieve interval specified using this function and the measurement interval of the waveform parameters on the DL750/DL750P are not synchronized.
- If the waveform parameter measurement is not complete within the specified retrieve interval, Not A Number is transmitted to the PC because there is no measured value. In this case, the cell displaying the measured value on Microsoft Excel is set to blank.

- **Setting the Trend Display Conditions**

**Selecting the Waveform Parameter to Be Displayed (Graph 1 and Graph 2)**

You can display two trend graphs. For each graph, you can specify the trend target waveform and the waveform parameter. When the waveform parameter is "Marker," you can set the Marker Position.

**Selecting the Target Waveform (Trace)**

From the Trace box, select the target waveform for the trend display from the following:

Chan1 to Chan16 (channels 1 to 16), DSP1 to DSP6 (optional), Math1 to Math8 (computed waveforms)

**Selecting the Waveform Parameter**

From the Parameter box, select the target waveform parameter of the trend display (same expression as the communication command) from the following: For the meanings of the waveform parameters and the marker cursor, see the explanation in section 11.6 or 11.5.

Parameter	DL750/DL750P Menu	Parameter	DL750/DL750P Menu
None	Not selected	MINIMUM	Min
AMPLITUDE	Amp	NOVERSHOOT	-OShot
AVERAGE	Avg	NWIDTH	-Width
AVGFREQ	AvgFreq	PERIOD	Period
AVGPERIOD	AvgPriod	PNUMBER	Pulse
BWIDTH1	Burst1	POVERSHOOT	+OShot
BWIDTH2	Burst2	PTOPEAK	P-P
DELAY (For a detail setting, use Delay Setup on the DL750/DL750P)	Delay	–	–
DUTYCYCLE	Duty	PWIDTH	+Width
FALL	Fall	RISE	Rise
FREQUENCY	Freq	RMS	Rms
HIGH	High	SDEVIATION	Sdev
LOW	Low	TY1INTEG	Int1TY
MAXIMUM	Max	TY2INTEG	Int2TY
Marker(M1<2>) (marker cursor for cursor measurements)	M1<2>	XY1INTEG	Int1XY
MIDDLE	Mid	XY2INTEG	Int2XY

**Setting the Marker Position**

You can set the marker position if "Marker(M1)" or "Marker(M2)" is selected as the waveform parameter.

**Setting the Conditions for Retrieving the Measured Values of Waveform Parameters (Common)**
**Number of Displayed Measured Values (Data Number)**

Select the number of measured values (measured values retrieved from the DL750/DL750P into the PC) to be displayed in the cells of Excel from the following: If the number of measured values exceeds the selected number, the values are cleared from the oldest values to display the newest measured values.

10, 20, 50, 100, 200, and 500

**Retrieve Interval**

Select the retrieve interval from the following. However, of the selected waveform parameters, select the interval to match the longest parameter cycle measured on the DL750/DL750P.

2 s, 5 s, 10 s, 30 s, and 60 s

### Measurement Range

You can set the range on the time axis for measuring the waveform parameter. Range1 and Range2 are the start and end points, respectively.

Selectable range:  $\pm 5$  div

Resolution: Varies depending on the record length.

However, the measurement start point cannot be set to the same point as the measurement end point or to a value to the right of the measurement end point.

### Turning ON/OFF the Statistics Display

- The statistics (Max, Min, and Average) of the waveform parameters retrieved into the PC can be displayed.
- To display the statistics, select the Statistics check box. Clear the check box to not display the statistics.
- The number of measurement values displayed in the cell of Excel is up to the number specified in "Number of Displayed Measured Values (Data Number)" on the previous page. The statistics are determined on all the measured data since the trend display was started, not on only the displayed measured values.

### Updating the Setup Condition

Click **Update** to update the Marker Position and Range that are set on the control Panel of the measurement trend window to match the newest setup conditions of the DL750/DL750P.

- **Starting/Stopping the Trend Display of the Measured Values of the Waveform Parameters**

#### Start

Click **Start/Stop**. The indicator illuminates in yellow, and retrieval of the measured values of waveform parameters starts at the specified retrieve interval. At the same time, Microsoft Excel starts, and the measured values and trend graphs are displayed/drawn. If the statistical display is turned ON, the statistics are also displayed. The retrieval of the measured value of waveform parameter continues until the operation is stopped.

#### Stop

- Click **Start/Stop** while the trend display is in progress. The indicator turns OFF, and the display and drawing of the measured values and trend graph stop.
- If you attempt to save the data to a file or close Excel while the trend display is in progress, a runtime error occurs. In this case, select **No** on the runtime error dialog box and close the dialog box. Then, click **Start/Stop** on the measurement trend window to stop the trend display. After stopping the trend display, save the file or close Excel.



Display Example of Measured Values, Trend Graphs, and Statistics

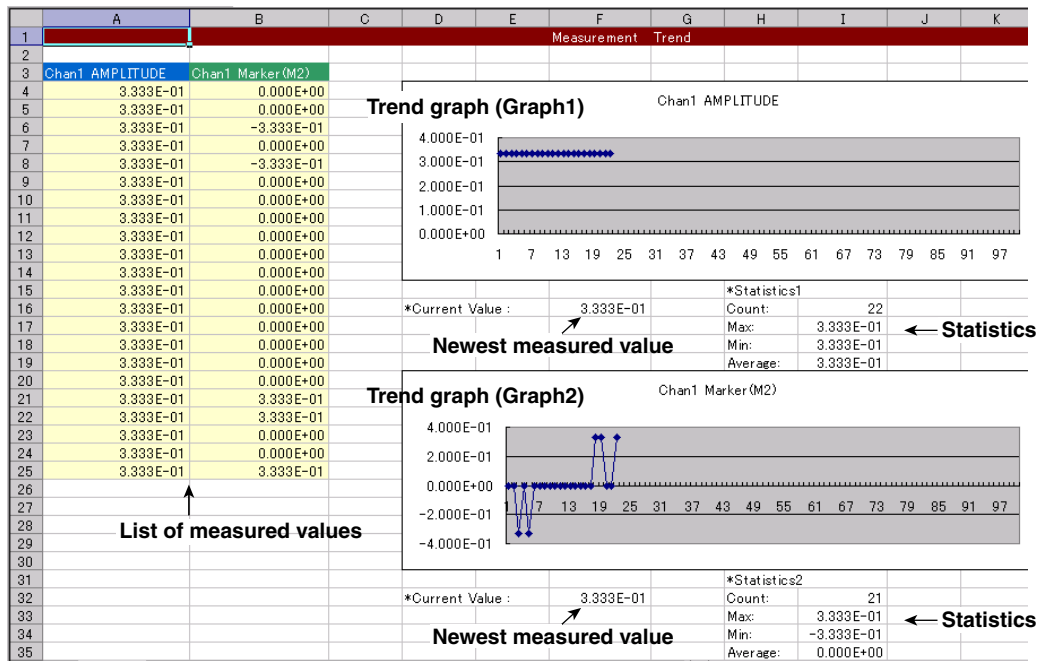

## 16.7 Using the Web Server Function

### Using the Control Script

Before using this function, check that the communication interface of the DL750/DL750P is set to Network (see page 16-26).

Click the **Control Script** icon on the Web server window. The Control Script window used to send communication commands (see the *Communication Interface User's Manual* IM701210-18E) to the DL750/DL750P and display the responses from the DL750/DL750P appears.

#### Web Server Window



#### Control Script Window

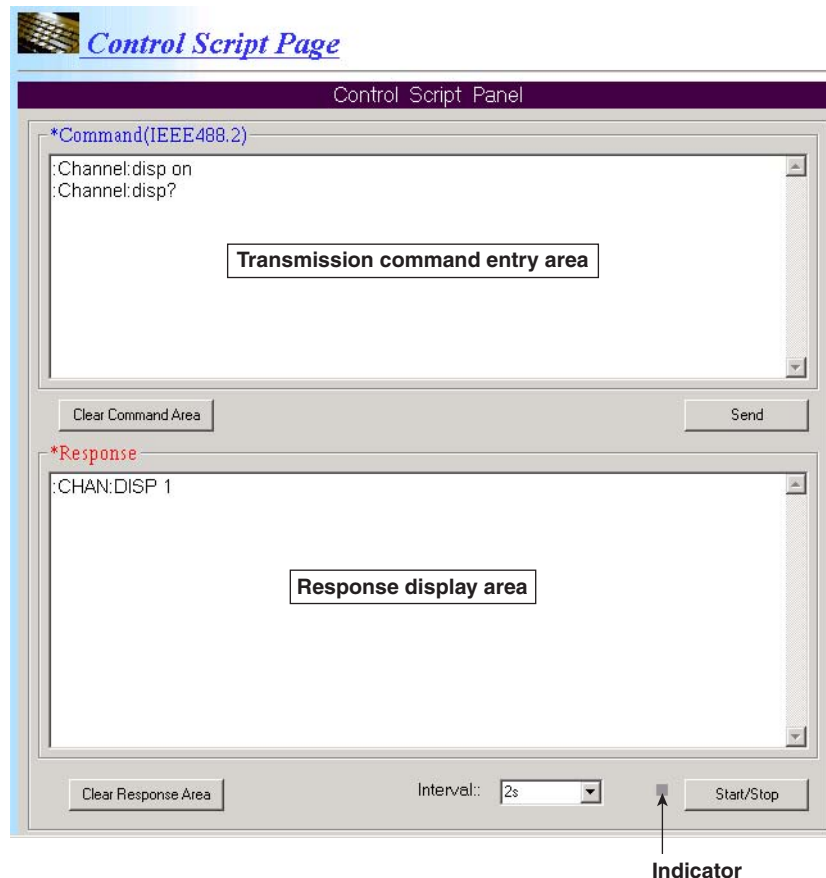

- **Sending Commands (\*Command IEEE 488.2)**

**Entering the Transmission Commands**

Enter the commands in the transmission command entry area.

Maximum number of input characters: Up to 50,000 (50 KB).

**Sending Commands**

Click **Send** to send the commands in the transmission command entry area collectively in the order displayed in the area.

**Clearing the Entered Commands (Clear Command Area)**

Click **Clear Command Area** to clear all the commands in the transmission command entry area.

- **Displaying the Responses from the DL750/DL750P (\*Response)**

The responses from the DL750/DL750P against the commands (queries) sent to the DL750/DL750P using the control script function can be received and displayed.

**Clearing the Responses (Clear Response Area)**

Click **Clear Response Area** to clear all the responses received from the DL750/DL750P that are displayed in the response display area.

- **Sending Commands Periodically and Displaying Responses**

The commands in the transmission command entry area can be sent periodically. If commands (queries) that request responses from the DL750/DL750P are sent, the responses from the DL750/DL750P are displayed in the response display area.

**Setting the Transmission Interval**

Select the command transmission interval from the following:

2 s, 5 s, 10 s, 30 s, and 60 s

**Starting Periodic Transmission (Start)**

Click **Start/Stop**. The indicator illuminates in yellow, and the command transmission and response display start at the specified transmission interval.

**Stopping Periodic Transmission (Stop)**

Click **Start/Stop** while the periodic transmission is in progress. The indicator turns OFF, and the command transmission and response reception/display stop. However, if the last command before stopping the periodic transmission was a query command, the response to that command is displayed in the response display area.

**Note**

- If a wrong command is sent, the error message is not automatically displayed in the Control Script window. The error code and message are displayed by entering the “:status:error?” command in the transmission command entry area and sending the command. You can also confirm the error on the screen image displayed using the data capture function and also on the DL750/DL750P screen.
- Binary data cannot be received or displayed.
- The transmission timeout is 30 s. Transmission and reception exceeding 30 s results in a timeout error. If all the commands specified in the transmission command entry area is sent, and the responses to the commands are not received within 30 s, a timeout error occurs.

**Displaying the Log**

Before using this function, check that the communication interface of the DL750/DL750P is set to Network (see page 16-26).

Click the **Log** icon on the Web server window. The Log window that can display the past log of errors that occurred on the DL750/DL750P, GO/NO-GO determination, and action-on-trigger appears. Up to the 30 newest incidents are logged. Logs older than the past 30 are not displayed.

**Web Server Window**

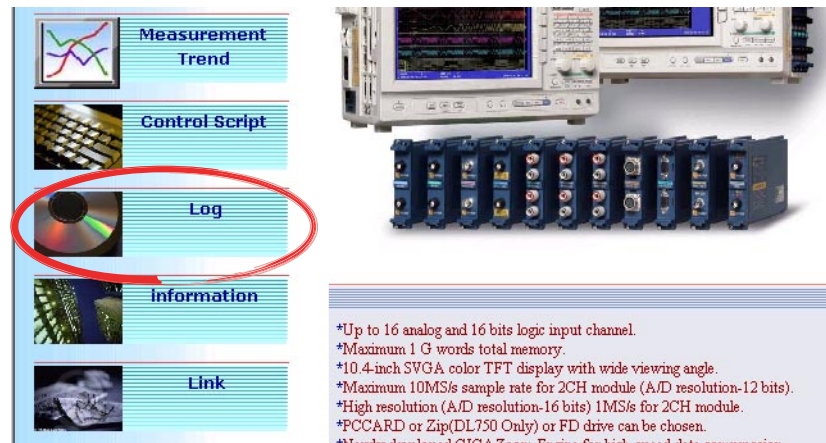

**Log Window**

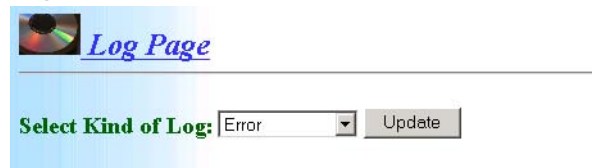

• **Displaying the Log**

**Selecting the Log Type (Select Kind of Log)**

From the list box, select the item for displaying the log from the following:

- Error (log of errors that occurred on the DL750/DL750P)
- Go/Nogo (log of GO/NO-GO determination)  
For the setup procedure for the GO/NO-GO determination, see sections 11.8 and 11.9.
- Action Trigger (log of action-on-triggers)  
For the setup procedure for the action-on-trigger, see section 6.18.

**Updating the Log (Update)**

Click **Update** to display the selected log. If the selected type of log is the same as that of the log being displayed, the log is updated.

• **Log Display Example**

The following figure shows an example displaying the log of GO/NO-GO determination.

Displays "Executing..." while GO/NO-GO determination is in progress or when action-on-trigger is in execution.

No	Date	Time	Factor	Action
3	2002/07/18	18:16:41.36	Param1(CH1,Max)	Buzzer,File: /SC4-1/0008.WVF ,Image: /SC4-2/0021.BMP ,Mailto:
2	2002/07/18	18:16:29.02	Param1(CH1,Max)	Buzzer,File: /SC4-1/0007.WVF ,Image: /SC4-2/0020.BMP ,Mailto:
1	2002/07/18	18:16:16.88	Param1(CH1,Max)	Buzzer,File: /SC4-1/0006.WVF ,Image: /SC4-2/0019.BMP ,Mailto:

If screen image data or waveform data files are being saved in the GO/NO-GO determination or action-on-trigger, the files can be saved on the PC from the Log display window.

The log of GO/NO-GO determination displays the save destination drive as follows.

- FD0:** Floppy disk
- ZP0:** Zip disk
- CA0:** PC card
- SC5:** SCSI device with the ID number set to 5\*
- SC5-1:** Partition 1 of a SCSI device whose ID number is 5\*
- ND0:** Network drive (when the Ethernet interface option is installed)
- US□-□:** USB storage device

└─ Partition number (or LUN (logical unit number))  
 └─ Address number

\* When a SCSI device whose ID number is 5 is connected

**Note**

- When the DL750/DL750P is printing, operating files (file operation from the front panel key or file transfer using the FTP server function), or realtime recording, files cannot be saved on the PC. In addition, other Web server functions cannot be used while saving files.
- Files on the network drive (NetWork) cannot be saved to the PC.

## 16.7 Using the Web Server Function

### Displaying the Instrument Information

Before using this function, check that the communication interface of the DL750/DL750P is set to Network (see page 16-26).

Click the **Information** icon on the Web server window. The Information window that displays the DL750/DL750P model (Model), the maximum record length available (Record Length), the module configuration (Module), the storage media type (Media), the presence of options (Option), ROM version (firmware version, Soft Version), and other information appears.

#### Web Server Window

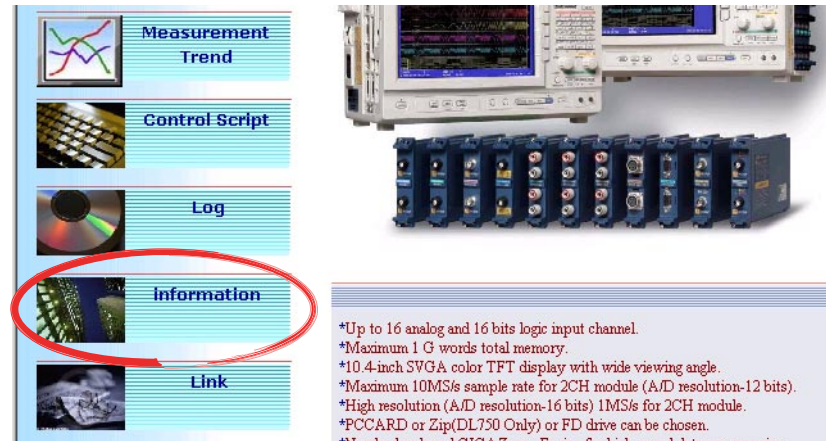

The screenshot shows the Web Server Window with five menu items: Measurement Trend, Control Script, Log, Information (highlighted with a red circle), and Link. To the right, there is an image of the DL750/DL750P instrument and its modules. Below the image, there is a list of specifications:

- \*Up to 16 analog and 16 bits logic input channel.
- \*Maximum 1 G words total memory.
- \*10.4-inch SVGA color TFT display with wide viewing angle.
- \*Maximum 10MS/s sample rate for 2CH module (A/D resolution-12 bits).
- \*High resolution (A/D resolution-16 bits) 1MS/s for 2CH module.
- \*PCCARD or Zip(DL750 Only) or FD drive can be chosen.
- \*Module developed GIGABYTE, Realtek, Asix, high speed data communication.

#### Information Window

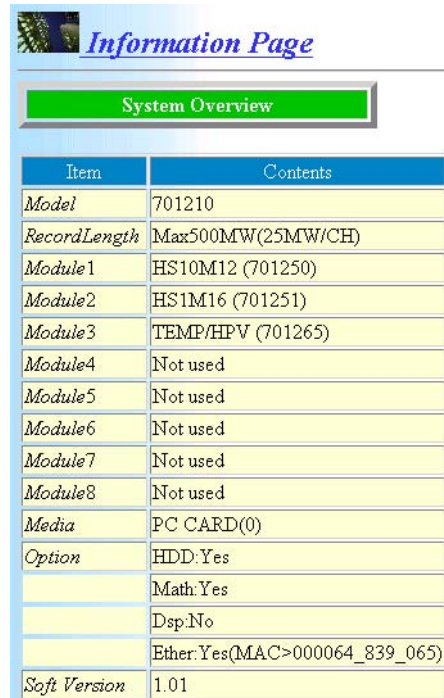

The screenshot shows the Information Window with the title "Information Page" and a "System Overview" section. Below this is a table with the following data:

Item	Contents
Model	701210
RecordLength	Max500MW(25MW/CH)
Module1	HS10M12 (701250)
Module2	HS1M16 (701251)
Module3	TEMP/HPV (701265)
Module4	Not used
Module5	Not used
Module6	Not used
Module7	Not used
Module8	Not used
Media	PC CARD(0)
Option	HDD:Yes
	Math:Yes
	Dsp:No
	Ether:Yes(MAC>000064_839_065)
Soft Version	1.01

### Viewing the Link

Before using this function, check that the communication interface of the DL750/DL750P is set to Network (see page 16-26).

Click the **Link** icon on the Web server window. You can view the Web page for the DL750/DL750P.

### Web Server Window

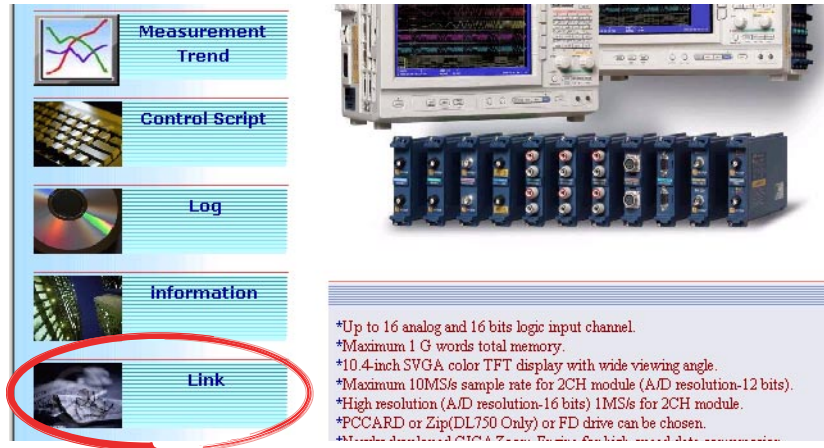

### Web Page Example (English Web Page)

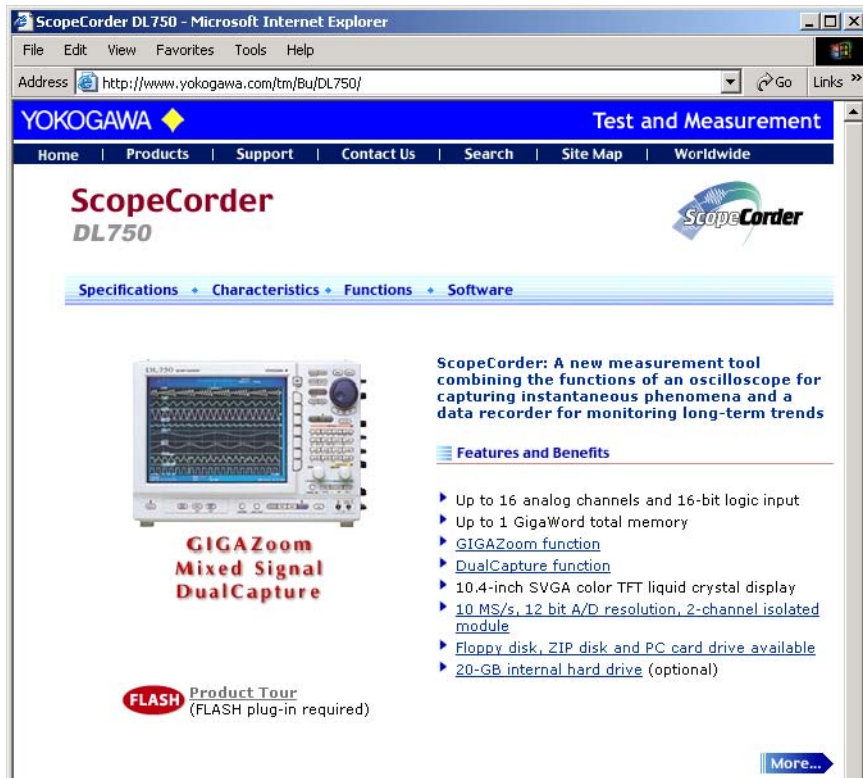

### Note

- To use the link function, the PC must be connected to the Internet.
- If the message language of the DL750/DL750P is set to English, the English Web page is displayed; if the message language is set to Japanese, the Japanese Web page is displayed; if the message language is set to Chinese, the Chinese Web page is displayed. For the setup procedure for the message language, see section 17.1.

# 16.8 Setting the Time Difference from GMT (Greenwich Mean Time)/SNTP

## Procedure

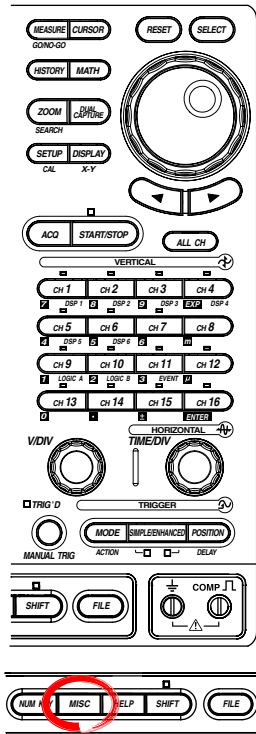

1. Press **MISC**.
2. Press the **Network** soft key.
3. Press the **Others** soft key. The Others setup menu appears.

### Setting the Time Difference from GMT

4. Use the **jog shuttle** and **SELECT** to set the Time Hour of Time Difference From GMT in the range of -12 to 13.
5. Likewise, set the Minute of Time Difference From GMT in the range of 0 to 59.

### Note

Minute can be specified only if Time Hour is set in the range of -11 to 12. (Minute cannot be specified if Time Hour is set to -12 or 13.)

### Setting the SNTP(Simple Network Time Protocol)

6. Use the **jog shuttle** and **SELECT** to set the Exec at Power On to ON or OFF.
7. Use the **jog shuttle** and **SELECT** to select SNTP Server.
8. Enter the IP address of the SNTP server according to the procedure given in section 4.2.
9. Use the **jog shuttle** and **SELECT** to select Time Out.
10. Enter the time out time in the range from 1-60 according to the procedure given in section 4.2.

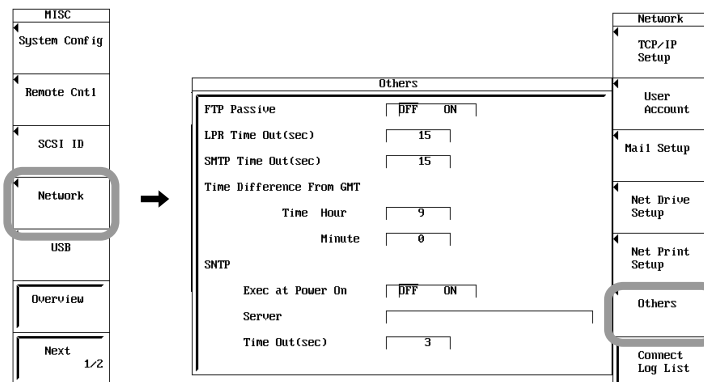



### Explanation

Set the time difference from GMT (Greenwich Mean Time). Make sure to set this value if you are using the Web server function.

#### Setting the Time Difference from GMT (Greenwich Mean Time)

Set the time difference in the range of –12 hour 00 minute to 13 hour 00 minute. For example, Japan standard time is ahead of GMT by 9 hours. In this case, set Time Hour to 9 and Minute to 00.

#### Checking the Standard Time

Check the standard time for the region where the DL750/DL750P is to be used using one of the following methods.

- Check the date and time settings on your PC.
- Check the site at the following

**URL:**<http://www.worldtimeserver.com/>

#### Note

---

The DL750/DL750P does not support daylight savings time. To set the daylight savings time, adjust the time difference from GMT.

---

#### Setting the SNTP

When turning ON the power to the instrument, the instrument's time is synchronized with that of the SNTP server connected to the network.

#### Note

- If a time difference from world standard time (Greenwich Mean Time) is specified, the time obtained from the SNTP server is adjusted accordingly, and that time is used.
  - When setting the date and time on the instrument, you can synchronize the time with the SNTP server. For details, see section 3.5, "Setting the Date and Time."
  - When not synchronizing the time with the SNTP server, do not enter the SNTP server's IP address.
-

## 16.9 Checking the Presence of the Ethernet Interface and the MAC Address

### Procedure

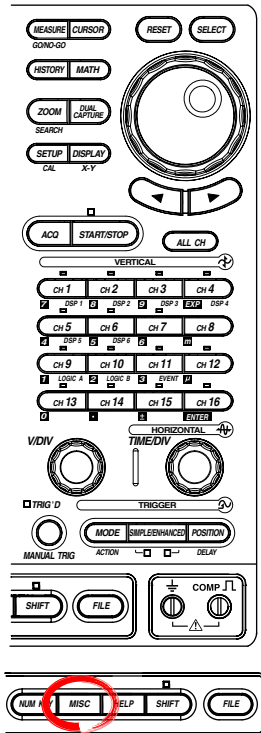

1. Press MISC.
2. Press the **Overview** soft key. The overview screen appears.
3. When Ether:Yes appears for the Option item in the overview screen, this indicates that the Ethernet interface is installed.  
The number indicated to the right is the MAC address (MAC:000064\_839\_065 in the following screen).

### Note

- Ether: Yes is displayed only if the Ethernet interface option is installed.
- If XXXXXX\_XXX\_XXX is displayed for the MAC address, contact your nearest YOKOGAWA dealer.

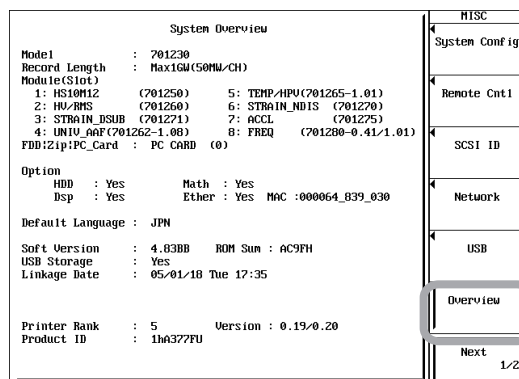

### Explanation

You can check the presence of the Ethernet interface and the MAC address. MAC address is a unique address that is pre-assigned to the DL750/DL750P.

#### The Presence of the Ethernet Interface

The presence of the Ethernet interface is displayed under “Ether” on the overview screen.

- Ether:Yes: The Ethernet interface is installed.
- Ether:No: The Ethernet interface is not installed.

#### MAC Address

MAC address is a unique address that is pre-assigned to the DL750/DL750P. It is necessary for transmitting data between nodes.

# 16.10 Setting the FTP Passive Mode and LPR/SMTP Timeout

## Procedure

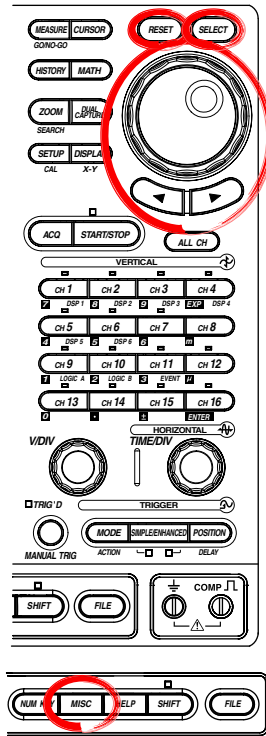

1. Press **MISC**.
2. Press the **Network** soft key.
3. Press the **Others** soft key. The Others setup menu appears.

### Selecting the FTP Passive Mode

4. Use the **jog shuttle** and **SELECT** to set FTP Passive to ON or OFF.

### Setting the LPR Timeout Time

4. Use the **jog shuttle** and **SELECT** to set LPR Time Out.

### Setting the SMTP Timeout Time

4. Use the **jog shuttle** and **SELECT** to set SMTP Time Out.

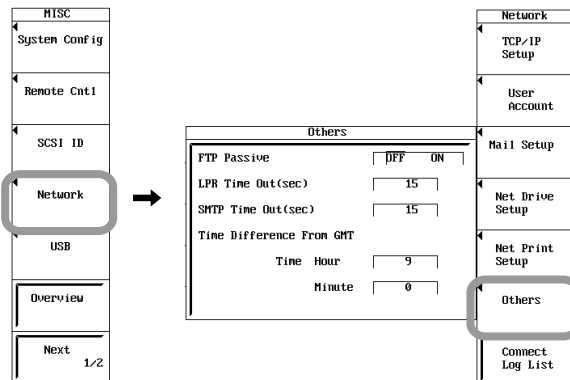

## Explanation

Special settings related to the FTP client, LPR, and SMTP are entered. Normally, these parameters do not need to be specified.

### Turning ON/OFF FTP Passive Mode

Turn this function ON when using the DL750/DL750P behind a firewall that requires the passive mode. The default setting is OFF. (A firewall is furnished on a system that has security features. It prevents intrusion from the outside into the network system.)

### Setting the LPR Time Out

The DL750/DL750P closes the connection to the printer if there is no response from the printer for a certain period of time (timeout time) when it accesses the printer. You can set the timeout value in the range of 0 to 3600 s. The default setting is 15 s.

### Setting the SMTP Time Out

When a mail server is accessed from the DL750/DL750P and connection cannot be established after a certain period of time (timeout time), the DL750/DL750P decides that the connection to the mail server is not possible and closes the connection. You can set the timeout value in the range of 0 to 3600 s. The default setting is 15 s.

# 16.11 Using the Instrument as a Windows Network Drive

## Procedure

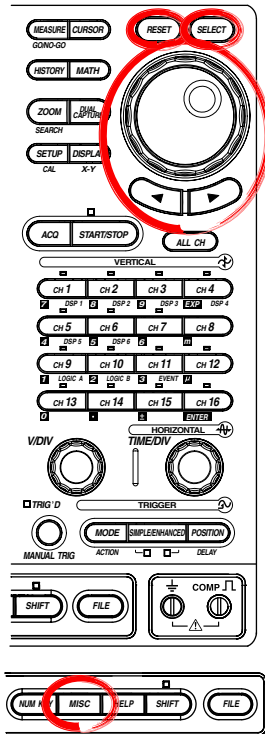

### Setting the DL750/DL750P

Follow the procedures in section 16.2, “Setting up the TCP/IP,” and section 16.6 “Accessing DL750/DL750P from a PC or Workstation (FTP Server Function)” to enter TCP/IP and user account settings, then connect to the network.

### Setting the PC

1. Open Entire Network Places.
2. Choose Map Network Drive under Tools on the menu bar. The Map Network Drive dialog box appears.



3. Select the drive to assign in the drive selection area.
4. Enter the instrument’s IP address in the folder input area using the format, `http://instrument's IP address/dav/`.
5. Click Finish. The enter user name and password input dialog box appears.
6. Enter the user name and password specified under user account (see section 16.6, “Accessing the DL750/DL750P from a PC or Workstation (FTP Server Function).”)
8. Click OK. The instrument is registered as a network drive.
9. To cancel the registration as a network drive, select Disconnect Network Drive under Tools on the menu bar. The disconnect network drive dialog box opens.
10. Select the network drive you wish to disconnect, and click OK.

**Explanation****Network Drive**

When the instrument is registered as a network drive, the files on the DL750/DL750P drive can be view using a software application running on a PC.

**Note**

- The DL750/DL750P can be mapped as a network drive only on Windows XP.
- When manipulating files using the network drive function, do not perform other network functions such as the FTP client/server function or Web server function. If you do, the DL750/DL750P or the PC may become unstable.
- Do not change the contents of the DL750/DL750P drive (including the contents of the drives connected via the SCSI) from the PC. Reading the contents of the drive is allowed.
- Never perform the following operations.
  - Delete files on the DL750/DL750P drive from the PC.
  - Add files on the DL750/DL750P drive from the PC.
  - Change the directory structure of the DL750/DL750P drive from the PC.
- If you attempt to move a large file from the PC to the DL750/DL750P, the file may be lost due to the limitations of Windows.
- You cannot manipulate the files simultaneously from multiple PCs.
- You cannot view a directory containing 1000 or more files.
- You cannot use the WebDAV function simultaneously with the Web server function.

**Available Characters**

This function uses the Windows WebDAV client function and the instrument's WebDAV server function . The characters that can be used with the WebDAV server function on this instrument are as follows.

0 to 9

A to Z, a to z

%, (, ) , \_

Therefore, please make note of the following.

- Files and folders whose names contain characters other than the ones indicated above cannot be saved on the DL750/DL750P's drive. Also, these files cannot be copied or moved.
- Files in the instrument' drive containing characters other than those listed above are not displayed in the file list using WebDAV.  
Also, these files and folders are not taken into account in the calculation of used disk space. Therefore, the actual amount of used disk space is different from the calculated amount of space.

**File Information**

If you copy files or folders from the instrument's drive to a Windows local disk, the creation date and time of the file or folder changes to that of the date and time copied. Likewise if you copy files or folders from a Windows local disk to the instrument's drive, the creation and modified dates and times of the file or folder changes to that of the date and time when copied.

# 17.1 Changing the Menu/Message Language and Turning the Click Sound ON/OFF

## Procedure

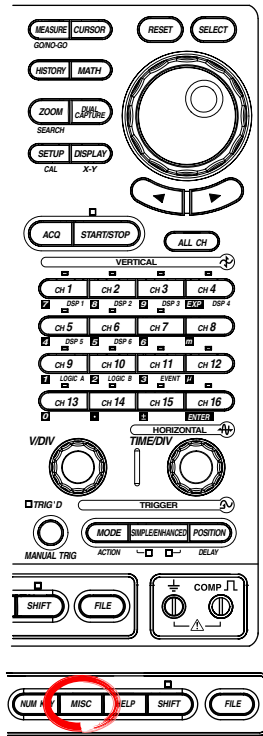

1. Press **MISC**.
2. Press the **System Config** soft key.

### Setting the Menu Language

3. Press the **Menu Language** soft key and press the soft key corresponding to the language you wish to use.

### Setting the Message Language

4. Press the **Message Language** soft key and press the soft key corresponding to the language you wish to use.

### Setting the Click Sound

5. Press the **Click Sound** soft key to select ON or OFF.

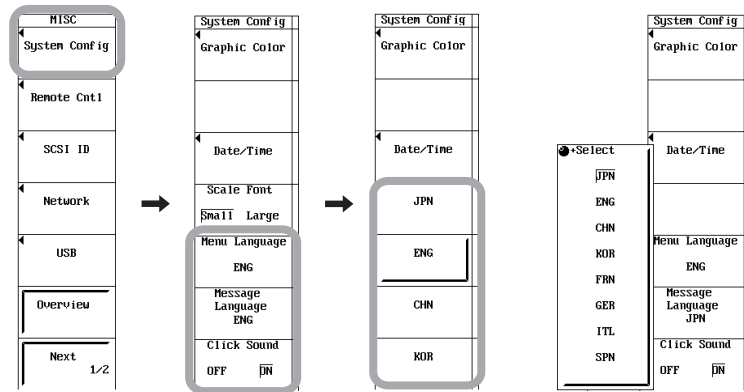

## Explanation

### Setting the Menu Language

You can set the menu screen to English (ENG), Japanese (JPN), Chinese (CHN), or Korea.

### Setting the Message Language

A message appears when an error occurs or when you press the HELP key. You can set the language of the messages to English (ENG), Japanese (JPN), Chinese (CHN), Korea(KOR), German(GER), French(FRN), or Italian(ITL). The messages codes are common in all languages. For a description of the messages, see section 18.2.

### Note

- Spanish (SPN) is displayed in the message language menu, but it is not supported in version 6.20. The message language will be set to English even if you select Spanish (SPN).
- If you specify Japanese, Chinese, or Korean for either the menu or message language, the other language specified must be either the same language, or English, German, French, or Italian.  
For example, if you specify Japanese for the menu language, you must specify Japanese, English, German, French, or Italian for the message language. In this example, if you were to select Korean for the message language, the menu language would be automatically reset to Korean.

### Turning ON/OFF the Click Sound

You can set whether to make click sounds when the jog shuttle is turned. The default setting is ON.

# 17.2 Switching the Screen Display Font Size

## Procedure

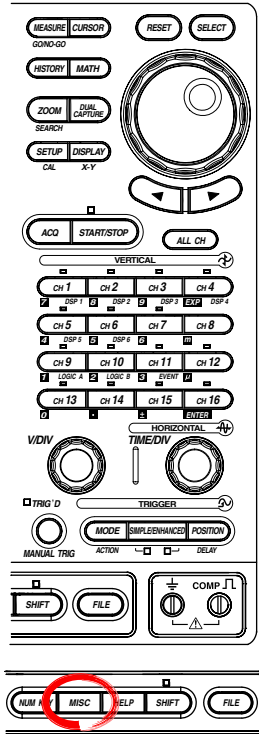

1. Press **MISC**.
2. Press the **System Config** soft key.
3. Press the **Scale Font** soft key to select Small or Large.

If Large is selected, the waveform labels displayed at the upper left of the waveform display area, the scale values of the vertical axis, and the trace labels (waveform labels) are shown using a large font.

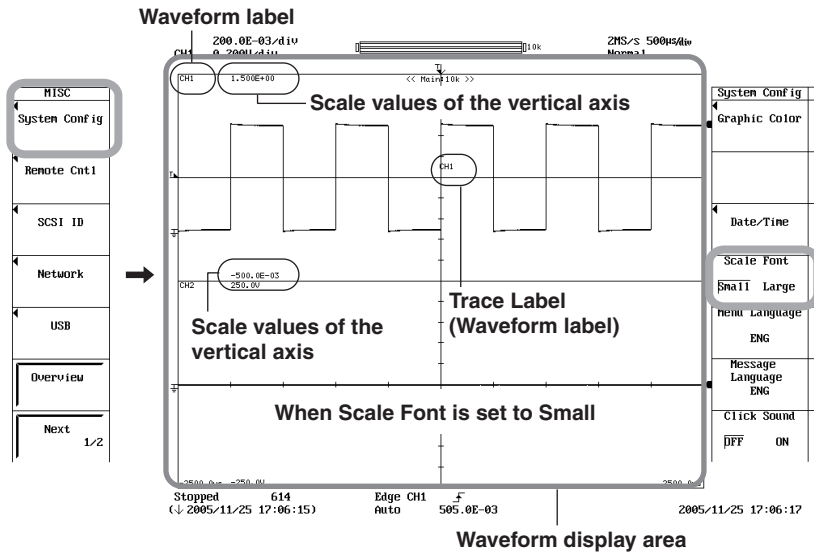

The font size in the area enclosed by ○ changes.

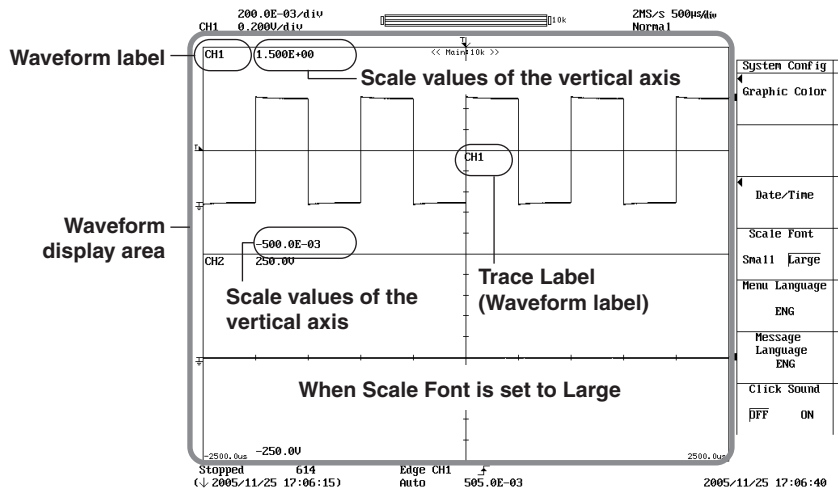

## Explanation

The screen display font size can be set to small or large. The default setting is Small. The font size changes for the waveform labels displayed at the upper left of the waveform display area, the scale values of the vertical axis, and the trace labels (waveform labels). If Large is selected and there are numerous waveforms displayed on the screen, the scale values of the vertical axis may overlap.

## 17.3 Changing the USB Keyboard Language

### Procedure

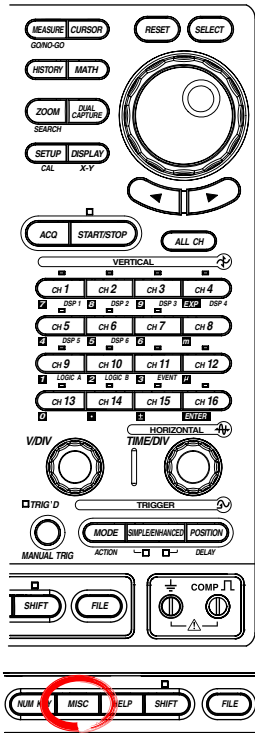

1. Press **MISC**.
2. Press the **USB** soft key.
3. Press the **USB Keyboard** soft key to select ENG or JPN.

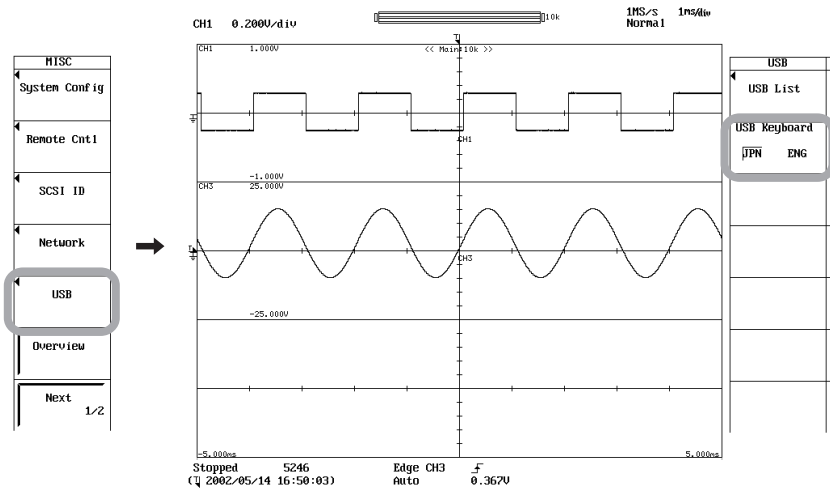

### Explanation

#### Setting the USB Keyboard Language

The language of the USB keyboard that is used to enter items such as file names and comments (see section 4.2) is specified. The following keyboards conforming to USB Human Interface Devices (HID) Class Ver1.1 can be used.

- ENG: 104 keyboard and 89 keyboard
- JPN: 109 keyboard and 89 keyboard

The character that is entered through each key of the USB keyboard varies depending on the keyboard type. For details, see appendix 8.

#### Note

For USB keyboards that have been tested for compatibility, contact your nearest YOKOGAWA dealer.



# 17.4 Setting the Screen Color and Brightness

## Procedure

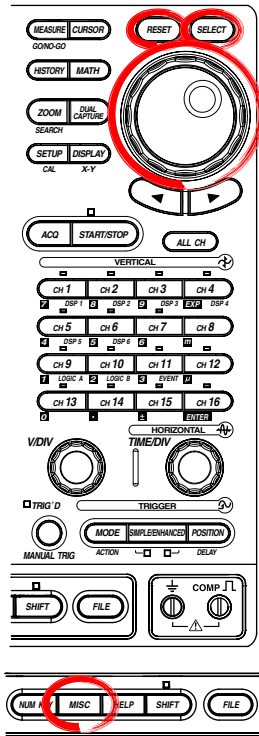

1. Press **MISC**.
2. Press the **System Config** soft key.
3. Press the **Graphic Color** soft key. The Graphic setup menu appears.

### Setting the Color

4. Use the **jog shuttle** and **SELECT** to select the item you wish to change the color. The color selection menu appears.
5. Use the **jog shuttle** and **SELECT** to select the color.

### Note

The items that you can change the color are as follows:

- CH1 to CH16
- DSP1 to DSP6 (optional)
- Math waveforms
- Logic A, Logic B
- Event
- Background
- Capture Area (sub waveform window of the dual capture function)
- Menu Base Color (menu screen)

In addition, the selectable colors are limited depending on the item.

### Setting the Brightness

6. Use the **jog shuttle** and **SELECT** to select the item you wish to change the brightness.
7. Turn the **jog shuttle** to set the brightness in the range of 1 to 15.

### Note

The items that you can change the brightness are as follows:

- Wave: Waveforms
- Menu
- Back Ground
- Capture Area: Sub waveform window of the dual capture function
- Snap/Zone: Snapshot waveforms/zones
- Grid
- Cursor
- Marker

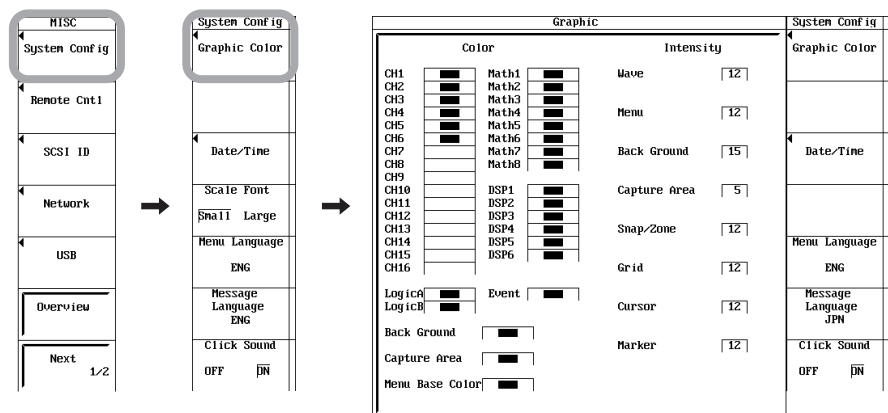

DSP1 to DSP6 are optional.

**Explanation****Screen Color**

You can set arbitrary colors for the following items.

The selectable colors vary depending on the item. See the color selection menu of each item.

CH1 to CH16:	Waveform color
DSP1 to DSP6 (optional):	Waveform color
Math1 to Math8:	Waveform color
Logic A, Logic B:	Waveform color
Event:	Waveform color
Back Ground:	Background color of the waveform display area
Capture Area:	Sub waveform window of the dual capture function
Menu Base Color:	Menu

**Brightness: Intensity**

You can set the brightness for the following items from 1 to 15 steps.

Wave:	Waveform
Menu	
Back Ground:	Background
Capture Area:	Sub waveform window of the dual capture function
Snap/Zone:	Snapshot waveforms/zones
Grid	
Cursor	
Marker	

## 17.5 Turning OFF the Backlight and Setting the Brightness of the Backlight

### Procedure

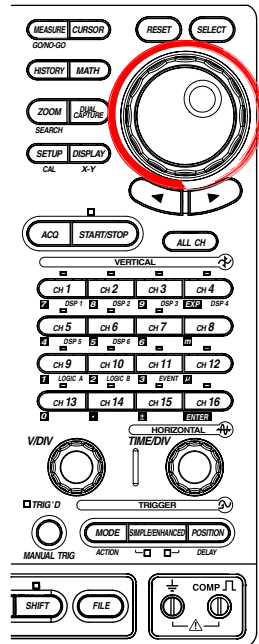

1. Press **MISC**.
2. Press the **Next 1/2** soft key.
3. Press the **LCD** soft key. The LCD setup menu appears.

### Setting Backlight Auto Off

4. Press the **Auto OFF** soft key to select ON or OFF.  
If you set Auto OFF to ON, proceed to step 5.
5. Press the **Auto OFF Time** soft key.
6. Turn the **jog shuttle** to set the time when the backlight will automatically turn OFF.

### Setting the Backlight Brightness

7. Press the **Brightness** soft key.
8. Turn the **jog shuttle** to set the backlight brightness.

### Turning ON/OFF the Backlight

9. Press the **LCD OFF Exec** soft key. The backlight turns OFF.  
Press any key to return to the measurement screen.

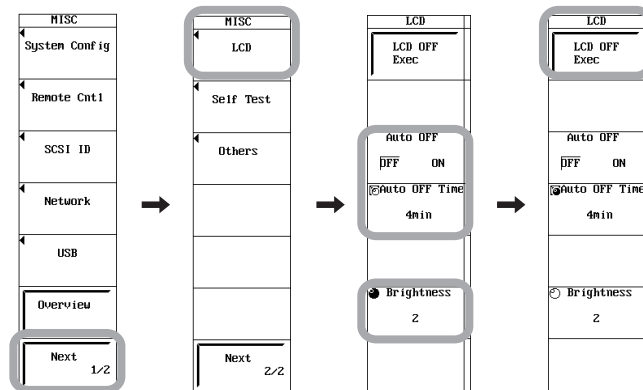

### Explanation

#### Turning ON/OFF the Backlight: LCD OFF Exec

Turns ON/OFF the LCD backlight. If a key is pressed when the backlight is OFF, the screen returns to the measurement screen.

#### Setting the Backlight Auto OFF: Auto OFF, Auto OFF Time

The backlight automatically turns OFF, if there is no key operation for the specified time.

#### Setting the Backlight Brightness

You can change the brightness of the backlight. Set the brightness in the range of 0 (darkest) to 7 (brightest).

The lifetime of the backlight can be prolonged by dimming the backlight or turning OFF the backlight when it is not necessary.

## 17.6 Locking the Keys

### Procedure

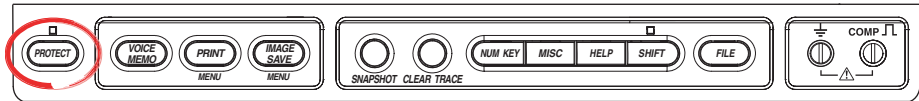

1. Press **PROTECT**. The LED above the key illuminates, and the keys are locked.
2. To release the lock, press **PROTECT** again.

### Explanation

This function locks the operation keys so that the current DL750/DL750P condition is not changed accidentally. When keys are locked, all keys other than the PROTECT key cannot be used.

### Note

When keys are locked, operations using the USB mouse and USB keyboard are also disabled.

# 18.1 Troubleshooting

## Troubleshooting

- If a message is displayed on the screen, read the succeeding pages.
- If servicing is necessary, or if the instrument is not operating correctly after performing the corrective actions below, contact your nearest YOKOGAWA dealer.

Problem	Probable Cause	Corrective Action	Reference Section
The power cannot be turned ON.	Using a power supply outside the ratings.	Use a correct power supply.	3.4
Nothing is displayed.	The backlight is turned OFF.	Press any key.	17.5
	The screen colors are not appropriate.	Power cycle the DL750/DL750P while holding down the <b>RESET</b> key.	17.4
The display is odd.	The system is abnormal.	Power-cycle the DL750/DL750P.	3.4
Keys do not work.	The DL750/DL750P is in the remote mode.	Press <b>SHIFT + CLEAR TRACE</b> enable local mode.	–
	Other causes.	Perform a key test. If the test fails, servicing is required.	18.3
	Protected.	Press the <b>PROTECT</b> key.	17.6
Trigger does not activate.	The trigger settings are not appropriate.	Set the trigger conditions correctly.	Chapter 6
Measured values are not correct.	Insufficient warm-up.	Warm up the DL750 for 30 minutes after turning on the power.	—
	Not calibrated.	Perform a calibration.	4.6
	The probe's phase has not been corrected.	Correct the phase properly.	3.7
	The probe attenuation is not correct.	Set an appropriate value.	5.6
	An offset voltage is added.	Set the offset voltage to 0 V.	5.10
	Other causes.	Perform a calibration. In addition, select Test Item: Carib.Inf. for the self test item and execute the self test. If the measured value is still odd, servicing is required.	4.6 18.3
Cannot output to built-in printer.	The printer head is damaged or worn out.	Servicing required.	–
Cannot save to the specified medium.	The medium is not formatted.	Format the medium.	13.5
	The medium is write-protected.	Release the medium's write-protect.	–
	No more free space on the medium.	Delete unneeded files or use a new medium.	13.15
Cannot change settings or control the operation of the DL750/DL750P via the communication interface.	The address of the DL750/DL750P used by the program is different from the specified address.	Match the address used in the program to the address of the DL750/DL750P.	Communication Interface User's Manual (IM701210-18E)
	The interface is not used in a way that conforms to the electrical or mechanical specifications.	Use it in a way that conforms to the specifications.	

## 18.2 Messages and Corrective Actions

### Error Message

A message may appear during operation. This section describes the meanings of the messages and their corrective actions. The messages can be displayed either in English or Japanese (see section 17.1). If the corrective action requires servicing, contact your nearest YOKOGAWA dealer for repairs.

In addition to the error messages below, there are communication error messages. These messages are described in the *Communication Interface User's Manual IM 701210-18E* (separate manual).

### Status Messages

Code	Message and Corrective Action	Section
51	File access is aborted.	Chapter 13
54	Exit from GO/NO-GO mode.	11.8, 11.9
55	Image printing was aborted.	Chapter 12
56	Cannot set all about zone.	11.9
57	Write to the EEPROM complete. Wrote module-specific information to the module.	–
58	Calibrating the temperature module.	–
59	Temperature module calibration complete.	–
60	The instrument is set to remote mode by the communication control. Press the SHIFT + CLEAR TRACE key to change to local mode.	–
62	Terminating...	–
63	Turned on pressing the RESET key. Will initialize.	4.4
64	A strain module is installed. Carry out automatic balancing before use.	–
65	The setting of the excitation voltage or the gauge factor was changed. Carry out automatic balancing before use.	–
66	Automatic balancing is running...	–
67	Automatic balancing is complete.	–
68	Test: SUCCESS	–
69	Calibration is running...	4.6
70	Calibration is complete.	4.6
71	Completed action-on-trigger.	6.17
73	Release the Preview mode.	12.2
75	Aborted the search.	11.2 to 11.4
76	Executed the search, but no record was found that matched the conditions.	11.2
77	Executed the search, but no record was found that matched the pattern.	11.4
78	Pattern contains points that are between Thr Lower and Thr Upper.	11.4
82	Aborted the statistical measurement.	–
83	This model does not have the DSP option installed.	–
84	Averaging is in progress.	11.1
85	Averaging has been completed.	11.1
86	Input module configuration was changed. Relevant settings have been initialized.	–
87	Parameter block has been set. Restart to update the instrument configuration information.	–
88	There is no dry cell. Insert batteries or turn the backup switch OFF.	7.10
89	All operation was aborted due to a power disruption. The data before the disruption is stored. No data was acquired during the disruption.	7.10
90	When history is set to "All," data of math channels is not saved. To store the data of math channels, set history to "One." * Data of channels other than math is saved.	11.1
91	This model does not have computation option installed.	–
92	This model does not have the HDD option installed.	–

Code	Message and Corrective Action	Section
93	Realtime recording is being prepared.	7.7
94	Media information is being read.	13.5
95	Failed to retrieve the data. Execute again.	Chapter 11
96	This setting not possible on DSP channels.	Chapter 15
97	The maximum sampling rate when using DSP channels is 5 MS/s. Slower sample rate than 2MS/s when set a DSP display.	Chapter 15
279	This command cannot be used in the current mode.	Chapter 9

### Errors in Execution (700 to 799)

Code	Message and Corrective Action	Section
701	Long copy is not possible when waveform acquisition is in progress. Press the START/STOP key to stop the waveform acquisition first.	7.1, 12.2
703	Undo is not possible since data that existed immediately before initialization and auto setup is not available.	4.4, 4.5
704	Can not be executed while running. Press START/STOP key to stop acquisition.	7.1
707	Can not Start while data out. Wait until output is completed.	7.1
708	Can not data out while running. Press START/STOP key to stop acquisition.	7.1
709	Can not detect listener. Check GP-IB connector.	–
710	File not found. Check the file.	Chapter 13
711	Cannot manipulate files while image printing is in progress. Wait until image printing is complete.	Chapter 13
712	Can not compress this hardcopy image. Turn off compression switch.	13.11
713	Calibration failure. Disconnect the input and execute again. If it fails again, servicing is necessary.	4.6
714	Temperature module calibration failed. Calibration value is invalid. Check the input signal.	4.6
716	Realtime recording to the internal hard disk is valid when the sampling rate is slower than the values shown below. 1~2 CH : 100 kS/s, 3CH : 50 kS/s, 4~5CH : 20 kS/s, 6~11CH : 10 kS/s, 12~18CH : 5 kS/s	7.7
717	Too many channels for the current T/div setting to realtime record. Decrease the number of channels by turning them OFF.	7.7
718	Too many channels to realtime record at the current record length. Turn OFF channels to reduce the number of channels or shorten the record length.	7.7
721	Can not operate while data out. Wait until output is completed.	7.7
723	Cannot load the realtime record.	7.7, 13.14
724	Balancing failed. * indicates the channel number of the channel for which automatic balancing failed.	–
725	Cannot be executed. Acquisition not active.	7.1
727	Insufficient output data. Increase Mag or widen the Time Range interval.	12.2
728	Image is being printed. Abort or wait until printing is complete.	Chapter 13
730	Pattern is not specified.	11.4
732	Cannot be executed while computation is in progress.	Chapter 10
733	Failed to measure statistics. Waveform data may be missing. If Cycle Statistics is specified, the instrument may be configured in a way that fails to detect the cycle.	11.7
735	Executing file Load, Save, or Format. Abort or wait until it is complete.	Chapter 13
736	Image is being printed or saved. Abort the operation or wait until the execution of the command is complete.	Chapter 13
737	A setup of an action trigger can't be carried out under the state of on.	6.18
738	Cannot be executed when the dual capture setting is ON.	7.6
739	Cannot be executed when realtime record or print setting is ON.	7.7
740	A time base can't be carried out under the state of the outside clock.	5.14
741	A start by the START key can't be done in the GO-NOGO mode.	11.8, 11.9

## 18.2 Messages and Corrective Actions

Code	Message and Corrective Action	Section
742	Because there are too many channels, it can't start in the length of the present record.	7.2
743	The indication mode of the history can't be carried out except for "Average".	11.1
744	Average practice can't be done because the record length of the history exceeds the record length that it can be carried out.	11.1
745	Set the trigger mode to Auto or Log for realtime hard disk recording. If the number of actions is set to Continuous, the only valid trigger mode is Log.	6.1, 7.7
746	Dual capture is not possible at the current record length. Shorten the memory length.	7.6
747	Dual capture is not possible if the main sample rate is faster than 100 kS/s or T/div is faster than 100 msec/div. Meet either of the conditions below. <ul style="list-style-type: none"> <li>• Shorten the record length (slower sample rate).</li> <li>• Decrease T/Div.</li> </ul>	5.2, 7.2, 7.6
748	Cannot start at the current record length. Shorten the record length or meet the following condition. <ul style="list-style-type: none"> <li>• Set the trigger mode to Auto, decrease T/Div to less than 100 msec/div to enable roll mode.</li> <li>• Set the trigger mode to Single or Log.</li> </ul>	5.2, 6.1, 7.2
749	Averaging mode is not possible when the trigger mode is Single, SingleN, or Log. Change the trigger mode.	6.1
751	A trigger can't start in case of dual capture in case of the one except for Auto or Log. Please change the trigger mode.	6.1, 7.6
752	Dual capture is not possible when set to average. Change the acquisition mode.	7.3, 7.6
753	Cannot start when the HISTORY or SEARCH menu is being displayed. Press the ESC key to clear the menu before starting.	11.2
754	Dual capture is not possible when set to X-Y or T-Y&X-Y. The capture window cannot be opened when set to X-Y or T-Y&X-Y.	7.6, 8.6
755	Time base cannot be set to external clock when set to envelope or box average.	5.14, 7.3
756	Cannot set accumulate during roll mode display. Turn Off accumulate.	5.2, 8.4
757	Cannot be executed when the acquisition mode is set to average. Change the mode.	7.3
758	Cannot copy if 50 pages is exceeded. Change the multiplier or range.	12.2
759	Realtime recording to the internal hard disk is valid when the record length is longer than 1 M.	7.2, 7.7
760	Cannot set the current drive on a realtime partition using communication commands.	7.7
761	Cannot be executed on realtime recorded waveforms.	7.7
762	Cannot be executed on waveforms in dual capture mode.	7.6
763	Long copy is not possible when X-Y display is present.	8.6
764	File recorded in realtime is currently being analyzed. Files being analyzed cannot be deleted.	7.7, 13.4
765	File recorded in realtime is currently being analyzed. The name of files being analyzed cannot be changed.	7.7, 13.17
766	File recorded in realtime is currently being analyzed. Partitions containing files that are being analyzed cannot be formatted.	7.7, 13.5
767	128 and more file can't be formed in the real-time area.	7.7
768	The file which failed in the real-time record can't be read.	7.7
769	Cannot start Single(N) when accumulate is On. Change the accumulate to Off.	6.1, 8.4
770	Cannot be executed when GO/NO-GO Mode is Zone.	11.9
771	Cannot play voice memo in the following situations: <ul style="list-style-type: none"> <li>* while waveforms are being read</li> <li>* when history display mode is not One</li> <li>* when the latest history record is not displayed</li> </ul>	7.9
772	Cannot record a voice memo when not in roll mode.	7.9
773	The measuring range is up to 10 MWords from measure start (TimeRange1).	6.17
774	Synchronizing signal not detected.	6.17
775	Set acquisition mode to Normal when using a wave window trigger.	6.17
776	The wave window trigger cannot be used if the sampling rate is faster than 500 kS/s or slower than 10 kS/s.	6.17
777	Range over. Change to an appropriate range then retry shunt calibration.	5.17
778	Statistical processing cannot be performed on waveforms recorded in real time.	11.7
779	Cannot detect a effective input signal at a Sync. channel.	6.17



Code	Message and Corrective Action	Section
780	Firmware was not overwritten in the following slots, since the version of the firmware in the module and that of the replacement firmware were the same. Check the versions on the overview screen. SLOT: XX	–
781	Cannot start while the following setup menus are displayed. Press the ESC key to clear the menu, and then start. (ALL CH, ZOOM, MEASURE, CURSOR, PrintSetup)	–
782	Firmware was not overwritten, since the version of the firmware in the printer and that of the replacement firmware were the same.	18.4
783	Checksum error in the printer control program. Recycle the power. If the error occurs again, maintenance service is required.	3.4
784	Failed to transmit the printer control program. Recycle the power. If the error occurs again, maintenance service is required.	3.4
785	Failed to write the printer control program. Recycle the power. If the error occurs again, maintenance service is required.	3.4
786	Cannot perform numeric recording when the floppy disk drive is specified. Select another drive with FileList and execute it again.	13.7
787	Cannot be carried out during recording. Press the START/STOP key to stop the waveform acquisition first.	7.1
788	Cannot start while the alert dialog box is open. Press the ESC key to clear the dialog box, and then start.	–
789	Cannot copy if 100 pages is exceeded. Change the multiplier or range.	9.8, 12.2
790	Fine Print or Zoom Print is not possible when X-Y display is present.	8.6, 12.2

### Errors in Setting (800 to 899)

Code	Message and Corrective Action	Section
800	Illegal date-time. Set the correct date and time.	3.5
801	Illegal file name. The file name contains characters which are not allowed or the file name is not a valid MS-DOS file name. Enter another file name.	Chapter 13
803	Turn off accumulate mode to enter history menu. It is not possible to activate the history menu by pressing the HISTORY key during accumulation.	8.4
804	Cannot change this parameter while running. Press the START/STOP key to stop acquisition.	7.1
806	Cannot change settings during GO/NO-GO. Stop the GO/NO-GO.	11.8, 11.9
808	Can not change display points with this T/div setting.	5.2
809	Cannot change edge for status other than X. Set the state of the channel corresponding to condition A to 'X'.	Chapter 6
811	Cannot change display points in roll mode.	5.2
813	Set Items in measure menu. Set appropriate measurement items.	11.6
814	Duplicated Name. Change the label string.	8.10
816	Cannot turn off with the current record length. Please Change record length.	7.2
817	Cannot change. Please change X Trace in the X-Y menu.	8.6
818	Cannot change when GO/NO-GO Mode is Zone.	11.9
819	Cannot change when Channel Display is OFF or Math settings are invalid. Set the channel display ON or make appropriate Math settings.	5.1, Chapter 10
821	Cannot change when External Clock is active.	5.14
823	Cannot change while running.	7.1
824	Cannot change with the current acq mode. Set the acquisition mode to Normal.	7.3
827	Illegal math expression. Input a correct computing equation.	10.5
829	Cannot change when Logic Mode is OFF or all bits of Logic Display are OFF.	5.20
830	Cannot set anything other than Low Pass for a Gaussian filter. Change the Filter Type to another filter besides Gaussian.	10.5
834	Duplicate SCSI ID. Set different ID numbers.	13.6
835	Cannot change settings while realtime printing or realtime recording. Stop printing or recording.	11.2

## 18.2 Messages and Corrective Actions

Code	Message and Corrective Action	Section
836	Cannot change settings during Action On Trigger. Stop the Action On Trigger.	6.18
837	Cannot set the channels which do not have modules installed.	–
838	Cannot set the channels which do not have the strain module installed.	–
839	Cannot Set or Execute.	11.10
840	If the trigger mode is set to Single, Single (N), or LOG, the acquisition mode cannot be set to Average.	6.1, 7.3
843	If the acquisition mode is Average, the trigger mode cannot be set to Single, Single (N), or Log.	6.1, 7.3
844	It can't be set at the time of the roll mode.	5.2
845	The trigger mode cannot be set to Single(N) during the roll mode.	5.2, 6.1
850	The acquisition mode cannot be set in the current record length.	7.2
851	Computation cannot be carried out at the current record length.	7.2
853	Cannot be configured or executed during the search operation.	11.2 to 11.4
855	Cannot be configured or executed during the history search operation.	11.2, 11.3
856	The record cannot be selected.	11.1 to 11.3
857	History record does not exist.	11.1 to 11.3
858	Cannot be configured or executed while computation is in progress. Aborted when history display mode is set to One.	11.1 to 11.3
859	It can't be set up or be carried out in the Preview mode. Choose Quit, and cancel the Preview mode.	12.2
860	Cannot be configured or executed while updating the history all display. Aborted when history display mode is set to One.	11.1 to 11.3
861	This format cannot output with color.	12.3, 12.4
862	Zones cannot be edited in the following cases: When the main window is not displayed. When the relevant waveform is not displayed.	11.9
863	The zone waveform does not exist.	11.9
865	Zones determination is not possible in the following cases: When the main window is not displayed. When the relevant waveform is not displayed. When the zone waveform does not exist.	11.9
867	Conflict in the waveform display plane. Set the Mode to something other than Zone using the GO/NO-GO menu.	11.9
868	Processing statistics. To perform other operations, abort the statistical processing.	11.7
869	The channel which couldn't be set up was specified.	Chapter 11, 13.7
870	Cannot be set when the acquisition mode is set to average.	7.3
871	Cannot be set in the dual capture mode.	7.6
872	Cannot be set during realtime recording.	7.7
873	It is an unacceptable parameter to set up to the present module.	Chapter 5
874	It can't be set up during the dual capture practice.	7.6
875	Cannot be set to a range of 20 sec/div to 3 day/div during roll display.	5.2
876	Because a record length is too long, it can't be set up by the present number of indication channels.	7.2
877	Cannot be set because there are too many display channels at the current record length. Shorten the record length.	7.2
878	Zooming is not available when the number of displayed points of the FFT waveform is less than 50 in the Zoom window. Aborted when history display mode is set to One.	10.3
879	It is the dual capture record length which can't be set up.	7.6
880	Cannot change this setting during realtime recording.	7.7
881	The time base cannot be set to external clock when the acquisition mode is set to envelope or box average.	7.3, 5.14
882	Spaces are not allowed for trace labels.	8.10
883	Cannot set accumulate during roll mode display.	5.2, 8.4
884	Cannot change the History parameter when accumulate is ON. Turn OFF accumulate first.	8.4
885	P-P compression cannot be used to save when a record length is 1 K.	13.7
886	Event channels cannot be displayed at the current record length.	7.2, 5.21

Code	Message and Corrective Action	Section
887	A sampling speed was too fast, and it could be folded, and a real-time queue was needed. Slow down a sampling speed.	7.7
888	A sampling speed was too fast, and it could be folded, and a real-time buffer was needed. Slow down a sampling speed.	7.7
889	Cannot set On this module.	6.17
890	Settings can not be entered for channels on which no strain module is mounted.	–
891	Cannot be changed when Variable is turned ON.	Chapter 15
892	A DSP channel cannot be specified for this trigger type.	Chapter 15
893	Cannot be set if Operation is set to something other than KnockFit.	Chapter 15
894	Cannot set this module when Operation is set to KnockFit.	Chapter 15
895	Cannot be set when the trace is set to a frequency module.	Chapter 15
896	Cannot be set when the trace is set to a DSP channel.	Chapter 15
897	The capture window cannot be changed while the dual capture is in progress, and while the measuring is in progress.	7.6
898	Cannot be set while the capture window is opened.	7.6

### System Operation Errors (900 to 999)

Code	Message and Corrective Action	Section
901	Failed to backup setup data. Will initialize. Backup battery may be low.	7.10
902	System RAM failure. Maintenance service is required.	–
903	System ROM failure. Maintenance service is required.	–
906	Fan stopped. Power off immediately. Maintenance service is required.	–
907	Backup battery is flat. Maintenance service is required to replace the back-up battery.	3.4
908	Internal temperature is too high. Power off immediately. Maintenance service is required.	3.4
909	Illegal SUM value. Maintenance service is required.	3.4
910	RAM read/write error. Maintenance service is required.	–
911	Memory bus error. Maintenance service is required.	–
912	Communication driver error.	–
914	Time out occurs in Communication.	–
915	EEPROM read error. EEPROM may be damaged. Maintenance service is required.	–
916	EEPROM write error. EEPROM may be damaged. Maintenance service is required.	–
917	No module installed. Install the module.	3.3
918	Turn ON the internal hard disk motor.	13.2
919	The current module installation condition and the setup data are inconsistent. Will initialize.	–
922	Cannot back up the acquisition memory. Memory will be initialized. The battery for acquisition memory backup may be flat.	7.10
928	Battery for waveform memory is flat. Waveform memory was initialized.	7.10
929	MS bus error occurred.	–
930	Slot 1 EEPROM error.	–
931	Slot 2 EEPROM error.	–
932	Slot 3 EEPROM error.	–
933	Slot 4 EEPROM error.	–
934	Slot 5 EEPROM error.	–
935	Slot 6 EEPROM error.	–
936	Slot 7 EEPROM error.	–
937	Slot 8 EEPROM error.	–
938	Key protect is enabled. To release the protection, press the PROTECT key.	17.6
939	This firmware is for the DL750P. It cannot be used on the DL750.	17.6
940	The USB device's power consumption exceeded the capacity of the USB hub.	19.8

## 18.2 Messages and Corrective Actions

### File Operation Errors (1000 to 1199)

Code	Message and Corrective Action	Section
1001	Invalid file name. * Duplicate file name or incorrect SCSI ID.	Chapter 13
1002	Cannot detect the medium. * Check the presence of the medium or the SCSI device connection.	Chapter 13
1003	Cannot detect the medium. * Check the presence of the medium or the SCSI device connection.	Chapter 13
1004	Media failure. Check the storage medium.	Chapter 13
1005	File not found. Check the file name and the storage medium.	Chapter 13
1006	Invalid file name. * Duplicate file name or incorrect SCSI ID.	Chapter 13
1007	Media failure. Check the storage medium.	Chapter 13
1008	Invalid file name. * Duplicate file name or incorrect SCSI ID.	Chapter 13
1009	Invalid file name. * Duplicate file name or incorrect SCSI ID.	Chapter 13
1010	Invalid file name. * Duplicate file name or incorrect SCSI ID.	Chapter 13
1011	The maximum number of files that can be stored in a single directory was exceeded. Save the file to another directory or medium.	Chapter 13
1012	Media full. Delete unnecessary file(s) or use another disk.	Chapter 13
1013	Cannot delete a directory if there are files in the directory.	13.15
1014	File is protected.	13.15
1015	Physical format error. Reformat the medium. If the same error occurs, the instrument is probably unable to execute a format on this medium.	13.5
1016	File system failure.	Chapter 13
1017	File system failure. Check using another disk. If the same message still appears, maintenance service is required.	Chapter 13
1018	File system failure. Check using another disk. If the same message still appears, maintenance service is required.	Chapter 13
1019	File system failure. Check using another disk. If the same message still appears, maintenance service is required.	Chapter 13
1020	File system failure. Check using another disk. If the same message still appears, maintenance service is required.	Chapter 13
1021	File is damaged. Check the file.	Chapter 13
1022	File system failure. Check using another disk. If the same message still appears, maintenance service is required.	Chapter 13
1023	File system failure. Check using another disk. If the same message still appears, maintenance service is required.	Chapter 13
1024	File system failure. Check using another disk. If the same message still appears, maintenance service is required.	Chapter 13
1025	File system failure. Check using another disk. If the same message still appears, maintenance service is required.	Chapter 13
1026	File system failure. Check using another disk. If the same message still appears, maintenance service is required.	Chapter 13
1027	File system failure. Check using another disk. If the same message still appears, maintenance service is required.	Chapter 13
1028	File system failure. Check using another disk. If the same message still appears, maintenance service is required.	Chapter 13
1029	File system failure. Check using another disk. If the same message still appears, maintenance service is required.	Chapter 13
1030	File system failure. Check using another disk. If the same message still appears, maintenance service is required.	Chapter 13
1031	File system failure. Check using another disk. If the same message still appears, maintenance service is required.	Chapter 13
1032	File system failure. Check using another disk. If the same message still appears, maintenance service is required.	Chapter 13

Code	Message and Corrective Action	Section
1033	File system failure. Check using another disk. If the same message still appears, maintenance service is required.	Chapter 13
1034	File system failure. Check using another disk. If the same message still appears, maintenance service is required.	Chapter 13
1035	File system failure. Check using another disk. If the same message still appears, maintenance service is required.	Chapter 13
1036	File system failure. Check using another disk. If the same message still appears, maintenance service is required.	Chapter 13
1037	File system failure. Check using another disk. If the same message still appears, maintenance service is required.	Chapter 13
1038	File system failure. Check using another disk. If the same message still appears, maintenance service is required.	Chapter 13
1039	File system failure. Check using another disk. If the same message still appears, maintenance service is required.	Chapter 13
1040	File system failure. Check using another disk. If the same message still appears, maintenance service is required.	Chapter 13
1041	File system failure. Check using another disk. If the same message still appears, maintenance service is required.	Chapter 13
1042	No media exists in SCSI device. Check that the storage medium is correctly inserted in the SCSI device.	13.4
1046	Media failure. Check the medium.	Chapter 13
1047	Media failure. Check the medium.	Chapter 13
1048	Media failure. Check the medium.	Chapter 13
1049	Media failure. Check the medium.	Chapter 13
1050	Media failure. Check the medium.	Chapter 13
1051	Media failure. Check the medium.	Chapter 13
1052	Media failure. Check the medium.	Chapter 13
1053	Media failure. Check the medium.	Chapter 13
1054	Media failure. Use a floppy disk of a format supported by the instrument.	13.1, 13.5
1055	Turn the HDD motor ON.	13.2
1100	Invalid record number.	Chapter 13
1101	File system failure.	Chapter 13
1102	File system failure.	Chapter 13
1103	File system failure.	Chapter 13
1104	File system failure.	Chapter 13
1105	File system failure.	Chapter 13
1106	File system failure.	Chapter 13
1107	File system failure.	Chapter 13
1108	File system failure.	Chapter 13
1109	Invalid media format.	Chapter 13
1110	Cannot load this file format. Files stored on other models (DL/AG series) cannot be loaded.	Chapter 13
1111	File is now being accessed. Execute after access is made.	Chapter 13
1112	Cannot be executed while running. Press the START/STOP key to stop acquisition.	7.1
1113	Cannot find '.HDR' file. Check the file.	13.7
1114	The specified file cannot be loaded on this ROM version or this model.	Chapter 13
1115	No ch is displayed. Turn ON the display of the appropriate channel.	5.1
1116	Save data not found. Check for presence of data.	Chapter 13
1118	SCSI controller failure. Maintenance service is required.	–
1119	HDD overrun error. Due to spare sectors, the recording could not be finished within assigned time. The operation is aborted.	–
1120	HDD error. An error occurred in the HDD. The operation is aborted.	–
1121	Unknown file format. Check the file.	Chapter 13
1124	Data that have been P-P compressed and saved cannot be loaded.	13.7

## 18.2 Messages and Corrective Actions

Code	Message and Corrective Action	Section
1125	Cannot directly load the sub waveform file (for example 0003DC.WVF). Specify and load the main waveform file (for example 0003.WVF).	7.6, 13.7
1126	Cannot save in this format at the current record length. Specify a range and save a section of the data. * Cannot create a file of size 2 GB or larger.	7.2
1127	Cannot load because the medium is selected. Select a setup file (SET).	13.8
1128	Cannot load because a directory is selected. Select a setup file (SET).	13.8
1129	Cannot load because the medium is selected. Select a binary file (.WVF).	13.7
1130	Cannot load because a directory is selected. Select a binary file (.WVF).	13.7
1131	Cannot load files larger than 50 MB on a network drive. Copy the file to the local drive before loading it.	Chapter 13
1132	Cannot load a HistoryAll binary file on a network drive.	13.7
1133	Turn the HDD motor ON.	Chapter 13
1134	If the realtime recorded file is converted to binary format, the converted file cannot be loaded.	13.7, 13.14
1135	Cannot save the waveform by specifying Z1 (Z2) for the range to be saved, if the zoom rate is set to x1. Save the waveform by specifying Main for the range to be saved.	13.7
1136	The file saved on the DL750P when the recorder mode is set to chart or X-Y cannot be loaded in the DL750.	Chapter 9
1137	Cannot make a directory or a file in the real-time area of the internal hard disk. Change the current directory.	7.7, Chapter 13
1138	Cannot save at the current PDF setting. Change the settings. * A file of size exceeding 2 GB cannot be created.	9.9, 13.13
1139	Cannot create PDF files on the network drive when the history waveform display format is set to All. Create the file on the local drive, and then copy it to the network drive.	9.9, 13.13

### Printer Errors (1200 to 1299)

Code	Message and Corrective Action	Section
1200	Move the release arm to the "HOLD" position.	12.1
1201	Paper empty. Load a roll chart.	12.1
1202	The printer head temperature is high. Printing will be aborted. Printing will not be possible until the printer head temperature comes down.	12.1
1203	Printer over heat. Power off immediately.	12.1
1204	Printer power supply error. Maintenance service is required.	12.1
1205	Printer time out. Maintenance service is required.	12.1
1206	USB printer error. Turn the power of the printer from OFF to ON.	12.3
1207	USB printer off-line.	12.3
1208	No paper.	12.3
1209	USB printer is in use.	12.3
1210	Cannot detect printer. Turn ON the printer. Check connectors.	12.3
1211	Printer is out of order. Maintenance service is required.	12.4
1212	Printer error. Turn the power of the printer from OFF to ON.	12.4
1213	Printer offline.	12.4
1214	Out of paper.	12.4
1215	Printer is in use.	12.4
1216	Cannot detect printer. Turn ON the printer. Check connectors.	12.4
1217	No applicable files for showing thumbnails.	13.12
1218	Print head temperature detection thermister is broken.	—
1219	Print head temperature detection thermister is shorted.	—
1220	Thumbnail execution is not possible when the floppy drive is specified. Select the image file from the file list and confirm with the SELECT key.	13.12

**Network Errors (1300 to 1399)**

<b>Code</b>	<b>Message and Corrective Action</b>	<b>Section</b>
1300	Cannot connect with ftp server. Confirm the network settings and connection.	Chapter 16
1301	Has not connect with ftp server yet. Confirm the network settings and connection.	Chapter 16
1302	This ftp function in not supported.	Chapter 16
1303	FTP Error: Pwd Confirm the network settings and connection.	Chapter 16
1304	FTP Error: Cwd Confirm the network settings and connection.	Chapter 16
1305	FTP Error: Rm Confirm the network settings and connection.	Chapter 16
1306	FTP Error: List Confirm the network settings and connection.	Chapter 16
1307	FTP Error: Mkdir Confirm the network settings and connection.	Chapter 16
1308	FTP Error: Rmdir Confirm the network settings and connection.	Chapter 16
1309	FTP Error: Get Confirm the network settings and connection.	Chapter 16
1310	FTP Error: Put Confirm the network settings and connection.	Chapter 16
1311	FTP Error: GetData Confirm the network settings and connection.	Chapter 16
1312	FTP Error: PutData Confirm the network settings, connection, and disk capacity.	Chapter 16
1313	FTP Error: AppendDataa Confirm the network settings, connection, and disk capacity.	Chapter 16
1314	FTP Error: Client Handle Confirm the network settings and connection.	Chapter 16
1315	FTP Error: Others Confirm the network settings and connection.	Chapter 16
1335	Cannot send data to a network printer. Confirm the network settings and connection.	12.4, 16.4
1336	Cannot send a mail. Confirm the network settings and connection.	16.5
1345	Test Error.	Chapter 16
1346	Test Success.	Chapter 16
1348	Failed to initialize network. Confirm the network settings.	Chapter 16
1349	The password entered the first time is different from the password entered the second time. Reenter the password for the second time.	Chapter 16
1350	Failed to acquire time from SNTP server. Confirm the network settings and connection.	16.8
1500	Cannot set when source channel is not a Volt Input.	Chapter 15
1501	Changed the network information. To apply the changes, power-cycle the DL750/DL750P.	Chapter 16
1502	Executed the firmware overwriting of the frequency module.	Chapter 16
1503	Overwriting firmware of the frequency module...	Chapter 16
1505	Executed the firmware overwriting of the built-in printer.	18.4
1506	Overwriting the printer firmware...	–
1600	This function can be used only when the recorder mode is Off.	Chapter 9
1601	Can be specified only when the recorder mode is Off.	Chapter 9
1602	Can be configured only when the recorder mode is Off. Print from the Reprint menu.	Chapter 9
1603	This function cannot be used when the recorder mode is set to X-Y.	9.7
1604	Cannot be configured or executed when the recorder mode is Off.	Chapter 9

## 18.2 Messages and Corrective Actions

---

Code	Message and Corrective Action	Section
1605	Repeat trigger cannot be specified. Repeat trigger is valid only during chart recorder mode when the print style is waveform and shot recording is not OFF.	Chapter 9
1606	Cannot be changed during X-Y recording.	9.7
1607	Cannot use wave window trigger when the recorder mode is set to chart or X-Y.	Chapter 9
1608	Cannot be specified when the print style is Numeric.	9.6
1609	Cannot Set or Execute on the DL750.	Chapter 9

### Other Errors (9999)

Code	Message and Corrective Action	Section
9999	This error No. is not defined.	–

**Note**

---

If servicing is required, initialize the instrument once for confirmation.

---



# 18.3 Self-Diagnostic Test (Self Test)

## Procedure

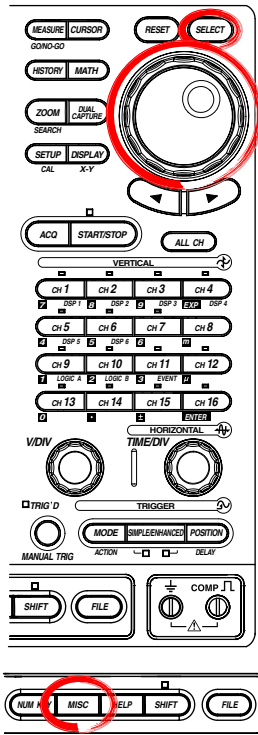

### Displaying the Self Test Menu

1. Press **MISC**.
2. Press the **Next 1/2** soft key.
3. Press the **Self Test** soft key.
4. Press the **Test Item** soft key. The test item selection menu appears. Use the **jog shuttle** and **SELECT** to select the item to be tested.

Proceed to step 5 for the memory test, step 7 for the key test, step 12 for the printer test, and step 14 for the floppy disk drive test, Zip disk drive test, PC card drive test, internal HDD test, or SCSI test.

### Executing the Memory Test

5. In step 4, select Memory.
6. Press the **Test Exec** soft key to execute the memory test.

### Executing the Key Test

7. In step 4, select Key Board.
8. Press the **Test Exec** soft key to execute the key test.
9. Press all the keys or press **ESC** twice to end the key test.

### Testing the soft keys

10. Press the **Soft Key** soft key. A soft keyboard appears.
11. Use the **jog shuttle** and **SELECT** to check that all the characters on the keyboard can be entered correctly.

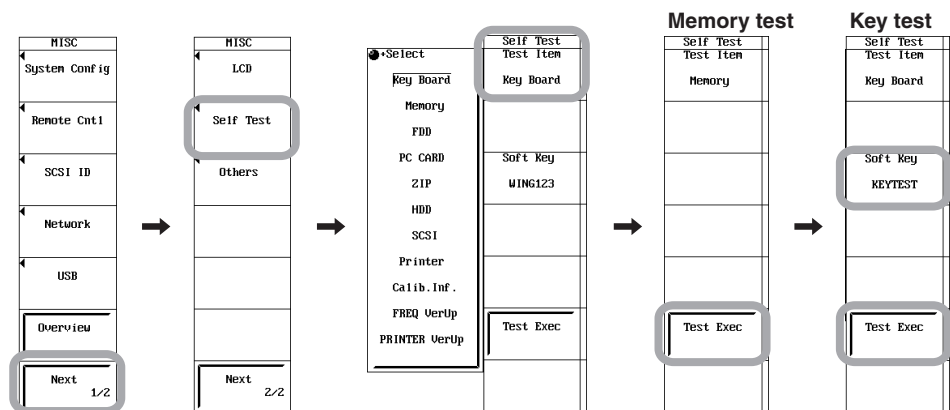

### Note

“FREQ VerUp” and “PRINTRE VerUp” that are displayed with the Test Item soft key are used when updating the frequency module firmware and the DL750P built-in printer firmware. For details on updating the firmware, see the following Web page.  
<http://www.yokogawa.com/tm/DL750/>

## 18.3 Self-Diagnostic Test (Self Test)

### Executing the Printer Test

- In step 4, select Printer.
- Press the **Test Exec** soft key to execute the printer test.

### Executing the Floppy Disk Drive, Zip Disk Drive, PC Card Drive, Internal HDD, or SCSI Test

- In step 4, select FDD, ZIP, PC CARD, HDD, or SCSI.
- Press the **Test Type** soft key.
- Turn the **jog shuttle** to set Test Type to #1.
- Press the **Test Exec** soft key to execute the test selected in step 14.

#### Note

- Insert a floppy disk, a Zip disk, or a PC card before executing the floppy disk drive, Zip disk drive, or PC card drive test.
- Note the following points when performing a SCSI test.
  - Connect the SCSI device.
  - Only test unpartitioned SCSI devices.
  - Set the SCSI ID to 1.
- Test Item > Calib.Inf. is a menu for the service personnel (maintenance).

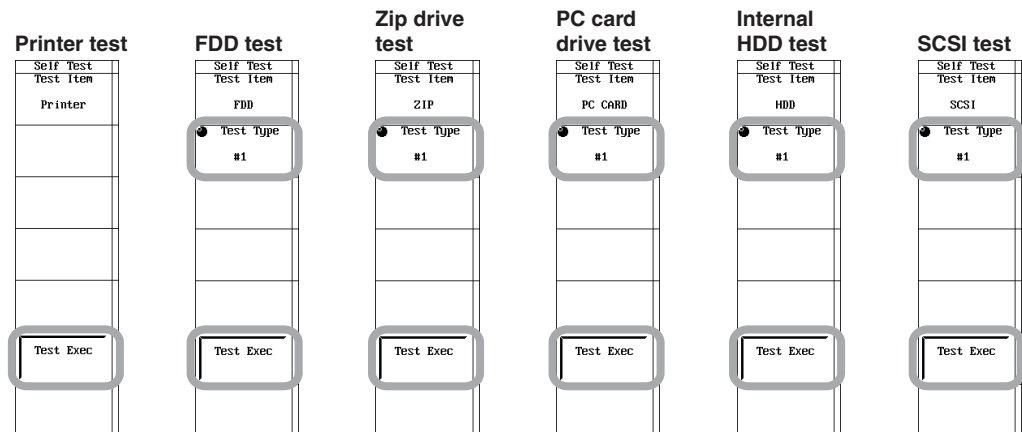

**Explanation****Memory Test**

Tests whether the RAM/ROM of the internal CPU board is operating correctly. If Pass is displayed, it is operating correctly.  
If there is an error, Fail is displayed.

**Key Test: Key Board**

Tests whether the front panel keys are operating properly. If the name of the key being pressed appears highlighted, it is operating correctly. If there is an error, the name of the key will not appear highlighted.  
Press the ESC key twice to quit the key test.

**Floppy Disk Drive, Zip Drive, or PC Card Drive Test: FDD, ZIP, PC CARD**

Tests whether the floppy disk drive, Zip drive, or PC card is operating properly. If there is an error, Fail is displayed after the test execution.

**Internal Hard Disk Drive (Optional) or SCSI Test: HDD, SCSI**

Tests whether the internal hard disk drive or SCSI is operating correctly. If there is an error, Fail is displayed after the test execution.

**Printer Test**

Tests whether the built-in printer is operating properly. If the tint is printed correctly, the operation is normal. If there is an error, the printing will not be correct.

**If an Error Occurs during the Self Test**

If the error remains after carrying out the following procedure, contact your nearest YOKOGAWA dealer.

- Perform the self test several more times.
- Check whether the medium to be tested is inserted.
- Check whether the internal hard disk (optional) motor is turned ON. (Section 13.2)
- Check whether the paper is properly set in the built-in printer. Check for paper jams (section 9.1 (section 12.1 for the DL750P)).
- Check whether the external SCSI device is connected properly. (Section 13.4)

## 18.4 Checking the System Conditions (Overview)

### Procedure

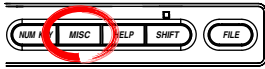

1. Press **MISC**.
2. Press the **Overview** soft key. The overview screen appears.  
Press any key to clear the overview screen.

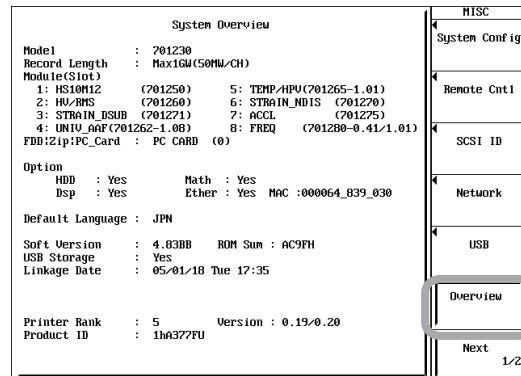

### Explanation

The following information can be confirmed on the Overview screen.

- Model: Model
- Record Length: Record length
- Module(Slot): Name of the Module<sup>1</sup> in the slot
- FDD|Zip|PC\_Card: Type of built-in medium drive
- Option: Presence of options (Yes/No)
- Default Language: Default language
- Soft Version: Version number of the software
- USB Storage: USB storage support (Yes: Supported, No: Not supported)
- Linkage Date: Version date of the software
- Printer Rank/Version: Printer firmware version (DL750P only)
- Product ID: Unique number attached to each instrument  
(Required when expanding the instrument with options sold separately.)

1. The 701265 (TEMP/HPV) and the 701280 (FREQ) are equipped with a CPU and firmware inside the modules. On the channels in which these modules are inserted, the version of the firmware installed in the module is also displayed on the screen.

- **701265 (TEMP/HPV)**  
TEMP/HPV (701265-X.XX)  
X.XX: Version of the software installed in the module.  
It is 1.01 in the screen above.
- **701280 (FREQ)**  
FREQ (701280-X.XX/Y.YY)  
X.XX: Version of the software installed in the module.  
It is 0.27 in the screen above.  
Y.YY: Version of the software in the DL750/DL750P that can be installed into the 701280 (FREQ). It is 0.41 in the screen above.

When the two versions above match, you do not have to upgrade the 701280 (FREQ). If they do not, check the upgrading procedure on the following Web page.

<http://www.yokogawa.com/tm/DL750/>

## 18.5 Recommended Replacement Parts

The three-year warranty applies only to the main unit of the instrument (starting from the day of delivery) and does not cover any other items nor expendable items (items which wear out).

Contact your nearest YOKOGAWA dealer for replacement parts.

Parts Name	Replacement Period
Built-in printer	[DL750] Under normal usage, 500 rolls of paper (part No.: B9988AE)
Built-in printer	[DL750P] Under normal usage, 1500 rolls of paper (part No.: 701966)
LCD backlight	Approx. 55000 hours under normal use

Parts Name	Warranty Period
Internal hard disk	One year after purchase (data is excluded)

The following items are expendable items. It is recommended that the parts be replaced according to the period indicated below. Contact your nearest YOKOGAWA dealer for replacement parts.

Parts Name	Recommended Replacement Period
Cooling fan	3 years
Backup battery (lithium battery)	5 years

## 19.1 Input Section

Item	Specifications
Number of input channels	16 channels + 16-bit log (8 bits ×2)
Type	Plug-in input unit
Number of slots	8 (2 channels per slot)
Maximum Record Length	Standard 2.5 MW/CH (16 analog channels + 6 DSP channels + 16-bit logic), 50 MW/CH max. /M1 option 10 MW/CH (16 analog channels + 6 DSP channels + 16-bit logic), 250 MW/(1CH) max. /M2 option 25 MW/CH (16 analog channels + 6 DSP channels + 16-bit logic), 500 MW/(1CH) max. /M3 option 50 MW/CH (16 analog channels + 6 DSP channels + 16-bit logic), 1 GW/(1CH) max.
DSP channel (optional)	6 dedicated computation channels (DSP channels) provided internal to the DL750/DL750P. Performs realtime computation of addition, subtraction, multiplication, and division (with or without coefficients), filtering, differentiation, integration, and knocking filtering using the 16 analog input channels as computation sources. (For detailed specifications of the computation function of the DSP channels, see section 19.5, "Function.") Below are the characteristics of the DSP channels <ul style="list-style-type: none"> <li>• The allocation of the acquisition memory of DSP channels is the same as analog input channels.</li> <li>• Can be used in all acquisition modes.</li> <li>• Can be set as a trigger source of simple triggers, the OR trigger of enhanced triggers, and window triggers.</li> <li>• Computed waveform can be displayed in realtime even during roll mode display.</li> <li>• Can be used as a target waveform of cursor measurements and automated measurement of waveform parameters.</li> <li>• Can be used as a target channel for the dual capture function.</li> </ul>

## 19.2 Trigger Section

Item	Specifications
Trigger mode	Auto, auto-level, normal, single, single(N), log, and repeat (only during Chart Recorder mode on the DL750P)
Trigger level range	CH1 to CH16: ±10 div around 0
Trigger hysteresis	When observing voltage: Select ±0.1 div, ±0.5 div, or ±1 div of the trigger level When observing temperature: When observing temperature: Select ±0.5° C, ±1.0° C, or ±2.0° C.
Trigger position	Can be set in 0.1% increments of the display record length
Trigger delay range	0 to 10 s (resolution is 100 ns)
Hold off time range	0 to 10 s (resolution is 100 ns)
Manual trigger key	Dedicated manual trigger key is available
Simple trigger	
Trigger source	CH1 to CH16, EXT (signal input from the TRIG IN terminal), LINE (commercial power supply signal that is connected), Logic A, Logic B, Time, and DSP1 to DSP6
Trigger slope	CH1 to CH16 and DSP1 to DSP6: Rising, falling, or rising/falling EXT, LOGIC A, LOGIC B: Rising or falling
Time trigger	Date (year/month/day), time (hour/minute), time interval (1 minute to 24 hours)
Enhanced trigger	
Trigger source	CH1 to CH16, Logic A, and Logic B (AND and OR possible on each logic bit)
Trigger type	A -> B(N): Trigger occurs nth time condition B becomes true after condition A becomes true. Count: 1 to 255 Condition A: Enter/Exit Condition B: Enter/Exit A Delay B: Trigger occurs first time condition B becomes true after specified delay following condition A true. Delay: 0 to 10 s (resolution is 100 ns) Condition A: Enter/Exit Condition B: Enter/Exit

## 19.2 Trigger Section

Item	Specifications
Edge on A:	Trigger occurs on the OR condition of the edge while condition A is true. Condition A: True/False
OR:	Trigger occurs on the OR of trigger conditions that are specified on multiple trigger sources. The OR condition can also be specified on each logic bit.
B > Time:	Trigger occurs when time of satisfaction of (pulse width trigger) condition B (time during which the condition is satisfied) is greater than or equal to a specified time. Specified time: 100 ns to 10 s (resolution is 100 ns)
B < Time:	Trigger occurs when time of satisfaction of (pulse width trigger) condition B is less than or equal to a specified time. Specified time: 100 ns to 10 s (resolution is 100 ns)
B Time Out:	Trigger occurs when the satisfaction of (timeout trigger) condition B reaches a specified time. Specified time: 100 ns to 10 s (resolution is 100 ns)
Period:	Periodic trigger. The following four types are available.
T > Time:	Trigger occurs when the period of condition T is greater than or equal to a specified time. Specified time: 100 ns to 10 s (resolution is 100 ns)
T < Time:	Trigger occurs when the period of condition T is less than or equal to a specified time. Specified time: 100 ns to 10 s (resolution is 100 ns)
T < T1 < T2:	Trigger occurs when the period of condition T is within a specified time range. Specified time: Time1: 100 ns to 10 s Time2: 200 ns to 10 s (resolution is 100 ns)
T < T1, T2 < T:	Trigger occurs when the period of condition T is outside a specified time range. Specified time: Time1: 100 ns to 10 s Time2: 200 ns to 10 s (resolution is 100 ns)
Window:	Trigger occurs when the trigger source enters or exits the range specified by two points. Window OR of multiple channels is possible. Logic bits can also be included in the edge OR condition.
Wave Window:	Trigger for monitoring the power supply. A realtime template is created by setting a tolerance (window width) to a waveform derived by averaging 1 to 4 cycles of waveforms before the current waveform. The current waveform is compared against the realtime template. If the current waveform falls outside the realtime template, a trigger is activated. <ul style="list-style-type: none"> <li>• Conditions A and B are parallel pattern conditions that are set separately to High, Low, or "Don't Care" for each channel (CH1 to CH16), Logic A, and Logic B.</li> <li>• OR conditions can be set to <math>\uparrow</math>, <math>\downarrow</math>, or "Don't Care" for CH1 to CH16, Logic A, and Logic B.</li> <li>• Hold off time cannot be specified for period triggers.</li> </ul>

## 19.3 Time Axis

Item	Specifications
Time axis range	Displayed using s/div, min/div, h/div, day/div. 500 ns/div to 1 s/div (in 1-2-5 steps), 2 s/div, 3 s/div, 4 s/div, 5 s/div, 6 s/div, 8 s/div, 10 s/div, 20 s/div, 30 s/div, 1 min/div to 10 min/div (in 1 min steps), 12 min/div, 15 min/div, 30 min/div, 1 h/div to 10 h/div (in 1 h steps), 12 h/div, 1 day/div, 2 day/div, 3 day/div
Time axis accuracy <sup>1</sup>	±(0.005%)
External clock input	Connector type: RCA jack Input level: TTL level (0 to 5 V) Valid edge: Rising edge Frequency range: 1 MHz or less Minimum pulse width: 400 ns or more for high and low

1. Under standard operating conditions (see section 19.11) after the warm-up

## 19.4 Display

Item	Specifications
Display	10.4" color TFT LCD monitor
Display screen size	211.2 × 158.4 mm
Display resolution <sup>1</sup>	SVGA 800×600 dots
Display resolution of the waveform display	650×512 (normal waveform display) or 750×512 (wide waveform display) selectable
Display format	Windows: Zoom: MAIN/MAIN&Z1/MAIN&Z2/MAIN&Z1&Z2/Z1only/Z2only Z1&Z2 X-Y: TY/XY/TY&XY
Maximum display update rate	30 times/s when a single waveform is displayed

1. Liquid crystal display may include few defective pixels. (Within 5 ppm (6 points) of the total number of pixels (including RGB)) The LCD is a high technology device made up of more than 1.44 million pixels. There may be pixels that do not turn ON or those that remain ON at all times. However, these cases are not malfunction.

## 19.5 Function

### Acquisition and Display

Item	Specifications
Acquisition mode	Normal: Normal waveform acquisition Envelope: Maximum sampling rate regardless of the T/div setting, holds the peak value Averaging: Average count 2 to 65536 (2 <sup>n</sup> steps) Box average: Increase the A/D resolution up to 4 bits (16 bits max.)
Record length	1 kW, 2.5 kW, 5 kW, 10 kW, 25 kW, 50 kW, 100 kW, 250 kW, 500 kW, 1 MW, 2.5 MW, 5 MW, 10 MW, 25 MW, 50 MW, 100 MW (/M1, /M2, or /M3 option), 250 MW (/M1, /M2, or /M3 option), 500 MW (/M2 or /M3 option), 1000 MW (/M3 option)
Zoom	Expand the displayed waveform along the time axis (up two locations using separate zoom rates)
Display format	1, 2, 3, 4, 8, 16 analog waveform windows
Display interpolation	Display samples using dot display, sine interpolation, or linear interpolation.
Graticule	Select from three graticule types.
Auxiliary display ON/OFF	Turn ON/OFF scale values, waveform labels, extra window, level indicator/numeric display.
X-Y display	Select the X axis and Y axis from CH1 to CH16, DSP1 to DSP6, MATH1 to MATH8 (up to 4)
Accumulation	Accumulates waveforms on the display (persistence mode)
Snapshot	Retains the current displayed waveform on the screen. Snapshot waveforms can be saved and loaded.
Clear trace	Clears the displayed waveform.
Dual capture	Performs data acquisition on the same waveform at two different sampling rates.
Main waveform (low speed)	Maximum sample rate: 100 kHz (roll mode region) Maximum memory length: 100 MW
Sub waveform (high speed)	Maximum sample rate: 10 MS/s Maximum memory length: 10 kW (fixed)
Realtime hard disk recording	Maximum sample rate: 100 kS/s (for 1 CH) max. Capacity: Up to 1 GW per operation Action count: Select Single or Continue. If Continue is selected, set the count in the range of 2 to 128. Features: Restore process not required. Saved to a format that can be loaded directly.
Voice memo	Records a voice as a memo while waveforms are being acquired (when in roll mode display). The recorded voice memo can be saved along with the waveform data. Maximum record time is 100 s.
Voice comment	Saves screen image data by attaching a voice comment (separate data from screen image data). The maximum length of voice comment that can be attached to a single screen image data is 10 s. Plays the voice comment from the File List window.



## 19.5 Function

### Vertical/Horizontal Axis Settings

Item	Specifications
Channel ON/OFF	Independently turn ON/OFF CH1 to CH16, DSP1 to DSP6, LOGIC A, LOGIC B, and EVENT.
ALL CH menu	Set all channels while displaying waveforms. Operation using the USB keyboard is possible.
Vertical axis expansion/reduction	Expand or reduce the vertical axis for each channel.
Variable	Upper/Lower limit scaling when variable is ON.
Input filter	Set for each channel.
Vertical position setting	Waveforms can be moved vertically in the range of $\pm 5$ div from the center of the waveform display frame.
Linear scaling	Set AX+B mode or P1-P2 mode independently for CH1 to CH16.
Roll mode	The roll mode is enabled when the trigger mode is set to auto, auto-level, single, or log, and the time axis setting is greater than or equal to 100 ms/div.

### Analysis

Item	Specifications
Search & zoom function	Search for, then expand and display a portion of the displayed waveform. Choose from the following two search methods.
Edge:	Counts the rising and falling edges and automatically searches an arbitrary edge
Auto scroll:	Automatically scrolls the zoom position.
History search function	Search for and display waveforms from the history memory that satisfy specified conditions.
Zone search:	Set an area on the screen, then extract and display only those waveforms that pass through the area (Pass mode), or do not pass through the area (By Pass mode).
Cursor measurement	The following cursors are selectable. Horizontal, Vertical, H&V (only during X-Y waveform display), Degree (only during T-Y waveform display), and Marker
Automated measurement of waveform parameters	Capable of performing automated measurement of waveform parameters. Automated measurement of waveform parameters within one period (P-P through Int2XY). Up to 24 items can be displayed. P-P, Amp, Max, Min, High, Low, Avg, Mid, Rms, Sdev, +OvrShoot, -OvrShoot, Rise, Fall, Freq, Period, +Width, -Width, Duty, Pulse, Burst1, Burst2, AvgFreq, AvgPeriod, Int1TY, Int2TY, Int1XY, Int2XY, Delay (between channels)
Statistical processing	Applicable items: Automated measured values of waveform parameters described above. Statistics: Max, Min, Avg, Sdv, and Cnt Maximum number of cycles: 48000 cycles (when the number of parameters is 1) Maximum total number of parameters: 48000 (total number of results) Maximum measurement range: 10 MW
Normal statistical processing	Performs statistical processing on all acquired waveforms while acquiring waveforms.
Cycle statistical processing	Performs statistical processing per cycle (cycle statistical computation). Extracts a periodic waveform (cycle) from the acquisition memory and automatically calculates waveform parameters per cycle.
Statistical processing of the history data	Performs automated measurement of waveform parameters on the waveform that is acquired using the history memory function and performs statistical processing. Statistical processing is performed from the oldest data.
Computation (standard)	Operators: +, -, $\times$ , /, binary computation, phase shift, and power spectrum
User-defined computation(optional)	Equations obtained by arbitrarily combining the following operators. ABS, SQRT, LOG, EXP, NEG, SIN, COS, TAN, ATAN, PH, DIF, DDIF, INTG, IINTG, BIN, P2, P3, F1, F2, FV, PWHH, PWHL, PWLH, PWLL, PWXX, DUTYH, DUTYL, FILT1, FILT2, HLBT, MEAN, LS-, PS-, PSD-, CS-, TF-, CH-, MAG, LOGMAG, PHASE, REAL, IMAG
Phase shift	Monitor waveforms by shifting the phase of CH1 to CH16. Computation is performed on the phase-shifted result.
GO/NO-GO determination	The following two types of GO/NO-GO determination are available <ul style="list-style-type: none"> <li>Determination using zones on the screen</li> <li>Determination using the result of the automated measurement of waveform parameters</li> </ul> Specify an action for GO or NO-GO result. Possible actions are screen image data output, waveform data storage, buzzer notification, and e-mail transmission. <sup>1</sup>

1. When the Ethernet interface option is installed

### DSP Channel Computation (Optional)

Item	Specifications		
Maximum computation rate	100 kS/s (6 channels simultaneously)		
Computed result	16 bits (2400 LSB/div: reference range)		
Applicable modules	All modules		
<b>Computation types</b>			
Addition, subtraction, multiplication, and division between channels +, −, ×, and ÷ (without coefficients)			
Filters	<ul style="list-style-type: none"> <li>• Sharp filter                             <ul style="list-style-type: none"> <li>Filter format: FIR</li> <li>Filter type: LPF/HPF/BPF</li> <li>Filter order: 8 to 194 orders (varies depending on the type and cutoff frequency. For details, see appendix 6.)</li> <li>Characteristics: Steep cutoff, linear phase, and little overshoot                                     <ul style="list-style-type: none"> <li>LPF: Cutoff frequency: 2% to 30% of fs (0.2% resolution) (fs = sampling frequency)</li> <li>HPF: Cutoff frequency: 2% to 30% of fs (0.2% resolution)</li> <li>BPF: Center frequency: 3% to 30% of fs (0.2% resolution),                                             <ul style="list-style-type: none"> <li>4.6% to 30% of fs (0.2% resolution), Bandwidth: 2% of fs</li> <li>7% to 30% of fs (0.2% resolution), Bandwidth: 5% of fs</li> <li>9.6% to 30% of fs (0.2% resolution), Bandwidth: 10% of fs</li> <li>12% to 30% of fs (0.2% resolution), Bandwidth: 15% of fs</li> </ul> </li> </ul> </li> <li>Cutoff characteristics: −40 dB at 2fc (LPF), −40 dB at 0.5fc (HPF) (fc = cutoff frequency)</li> <li>Phase: Linear phase characteristics</li> </ul> </li> </ul>		
	<ul style="list-style-type: none"> <li>• Gauss filter                             <ul style="list-style-type: none"> <li>Filter format: FIR</li> <li>Filter type: LPF</li> <li>Filter order: 5th to 49th order (varies depending on the type and cutoff frequency. For details, see appendix 6.)</li> <li>Characteristics: Smooth cutoff characteristics, linear phase, and no overshoot                                     <ul style="list-style-type: none"> <li>LPF: Cutoff frequency: 2% to 30% of fs (0.2% resolution) (fs = sampling frequency)</li> </ul> </li> <li>Cutoff characteristics: <math>-3.0 \times (f/f_c)^2</math> dB (f: frequency, fc: cutoff frequency)</li> <li>Phase: Linear phase characteristics</li> </ul> </li> </ul>		
	<ul style="list-style-type: none"> <li>• IIR (Butterworth) filter                             <ul style="list-style-type: none"> <li>Filter format: IIR (Butterworth)</li> <li>Filter type: LPF/HPF/BPF</li> <li>Filter order: 4th order</li> <li>Characteristics: Characteristics close to an analog filter, flat pass band, and overshoot                                     <ul style="list-style-type: none"> <li>LPF: Cutoff frequency: 0.2% to 30% of fs (0.2% resolution) (fs = sampling frequency)</li> <li>HPF: Cutoff frequency: 0.2% to 30% of fs (0.2% resolution)</li> <li>BPF: Center frequency                                             <ul style="list-style-type: none"> <li>0.6% to 30% of fs (0.2% resolution) Bandwidth: 1% of fs</li> <li>1.2% to 30% of fs (0.2% resolution) Bandwidth: 2% of fs</li> <li>2.6% to 30% of fs (0.2% resolution) Bandwidth: 5% of fs</li> <li>5.2% to 30% of fs (0.2% resolution) Bandwidth: 10% of fs</li> <li>7.6% to 30% of fs (0.2% resolution) Bandwidth: 15% of fs</li> <li>10.2% to 30% of fs (0.2% resolution) Bandwidth: 20% of fs</li> </ul> </li> </ul> </li> <li>Cutoff characteristics: −24 dB/Oct</li> <li>Phase: Nonlinear phase characteristics</li> </ul> </li> </ul>		
	<ul style="list-style-type: none"> <li>• MEAN (moving average)                             <ul style="list-style-type: none"> <li>Filter format: FIR (moving average)</li> <li>Filter type: LPF</li> <li>Filter order: Select from 2, 4, 8, 16, 32, 64, and 128</li> <li>Characteristics: Comb-shaped cutoff characteristics, high noise suppression effect, and no overshoot</li> </ul> </li> </ul>		
	Differentiation	LPF (bandwidth limit) ON/OFF possible LPF (sharp): Cutoff frequency: 2% to 30% of fs (0.2% resolution)	
	Integration/Summation	Reset condition of integration: Acquisition start and ON/OFF of the channel	
		Selectable reset conditions	
		Over Limit (±10div):	When the computed value exceeds +10 divisions or −10 divisions of the Value/Div setting
		Zero Cross to Positive:	When the source signal produces a positive edge at the zero-crossing point
		Zero Cross to Negative:	When the source signal produces a negative edge at the zero-crossing point

## 19.5 Function

Item	Specifications
	<p>Addition, subtraction, multiplication, and division between channels with coefficients</p> <p>Expression: +, -, ×, and ÷</p> <p>Computation format: A, B, C can be defined</p> <p>Addition: <math>(A \times S1) + (B \times S2) + C</math></p> <p>Subtraction: <math>(A \times S1) - (B \times S2) + C</math></p> <p>Multiplication: <math>(A \times S1) \times (B \times S2) + C</math></p> <p>Division: <math>(A \times S1) \div (B \times S2) + C</math></p> <p>Selectable range of coefficients A, B, and C: <math>\pm 9.9999E+30</math> to <math>\pm 9.9999E-30</math></p>
Knocking filter	<p>Filter that sets the output to 0 when the source channel signal is less than or equal the elimination level.</p> <p>Selectable filter</p> <p>FIR: HPF/BPF</p> <p>IIR: HPR/BPF</p> <p>Differentiation: LPF (bandwidth limit) ON/OFF possible</p>
Variable ON/OFF	<p>When variable is set to OFF (zooming in or out by setting the zoom rate)</p> <p>Value/Div: 123 Value/Div settings can be specified using the V/DIV knob (1-2-5 steps). 10.00E-21 [Value/Div] to 500.0E+18 [Value/Div]</p> <hr/> <p>When variable is set to ON (vertical zoom/expand according to the upper and lower limits of the display range)</p> <p>Upper and lower limits: <math>\pm 5.0000E+22</math> [Value/Div] / <math>\pm 1.0000E-23</math> [Value/Div]</p> <p>Display range: Up to <math>\pm 5.0000E+21</math>. (500.0E+18 [Value/Div] × 10 [Div]) The display will be clipped at higher values.</p> <p>Computation delay: [4 samples + the computation delay of the digital filter] (For details, see appendix 6.) The computation time of filters is proportional to the sample rate of the DSP channel. If the output result is specified as a source of another DSP channel, the computation delay increases.</p> <p>Can specify analog channels (CH1 to CH16) as computation sources. The computed result of a DSP channel can also be specified as a computation source of another DSP channel. However, only DSP channels with a channel number smaller than itself can be specified. The maximum sample rate of analog channels is 5 MS/s when a DSP channel is turned ON.</p>

## Recorder Mode (DL750P only)

Item	Specifications
Realtime recording on the built-in printer	<p>T-Y waveform recording/numeric value recording: Output to the chart in realtime.</p> <p>X-Y waveform recording: Starts data acquisition with START and generates X-Y waveforms in realtime. Outputs X-Y waveforms to the chart with STOP.</p>
Length of data saved to memory while realtime recording	<p>T-Y waveform recording: Fixed to 2.5 MW Automatically saves up to 1000 divisions of data (depending on the chart speed).</p> <p>X-Y waveform recording: Fixed to 1 MW</p>
Recording start trigger	<p>Recording can be started using a trigger by setting the trigger mode.</p> <p>Auto: Trigger disabled. Continuous recording. Recording starts with measurement start.</p> <p>Log: Trigger disabled. Recording stops when the memory storage length of data is acquired. When short recording is specified, recording stops when shot recording ends.</p> <p>Single: Trigger enabled. Recording starts after a trigger detection. When short recording is specified, recording stops when shot recording ends.</p> <p>Repeat: Trigger enabled. Recording starts after a trigger detection. Selectable only when shot recording is specified. Reenters trigger-wait state after short recording.</p>
Chart speed (T-Y waveform recording)	20 mm/s, 10 mm/s, 5 mm/s, 2 mm/s, 1 mm/s, 100 mm/min, 50 mm/min, 25 mm/min, 20 mm/min, 10 mm/min, 5 mm/min, 2 mm/min, 1 mm/min, 100 mm/h, 50 mm/h, 25 mm/h, 20 mm/h, or 10 mm/h
Output interval (Numeric value recording)	1 s, 2 s, 5 s, 10 s, 15 s, 20 s, 30 s, 1 min, 2 min, 5 min, 10 min, 15 min, 20 min, 30 min, or 60 min
Sample rate during X-Y waveform recording	5 kS/s, 2 kS/s, 1 kS/s, 500 S/s, 200 S/s, 100 S/s, 50 S/s, 20 S/s, 10 S/s, or 5 S/s

Item	Specifications
Recording format	<p>T-Y waveform recording: 1 division recording 200 mm/zone or 160 mm/zone (flexible zone is selectable for 1 division recording)</p> <p>2 division recording 80 mm/zone or 100 mm/zone</p> <p>3 division recording 60 mm/zone or 65 mm/zone</p> <p>4 division recording 40 mm/zone or 50 mm/zone</p> <p>8 division recording 20 mm/zone</p> <p>16 division recording 10 mm/zone</p> <p>Numeric value recording: Print direction selectable from standard and 180° rotation.</p> <p>X-Y waveform recording: Records up to 4 waveforms simultaneously. Assignment of X and Y channels on the 4 waveforms is arbitrary.</p>
Graticule	<p>Width: Selectable from 1 div and 10 mm.</p> <p>Type: Selectable from two types and OFF.</p> <p>Density: Dark/Light selectable.</p>
Recorded contents	<p>Simultaneously prints, scale, channel label, graticule, timestamp, gauge, annotation, etc.</p> <p>During T-Y waveform recording</p> <p>Scale: Prints the scale value for each channel. Select the print interval from OFF, 200, 400, and 800 mm.</p> <p>Channel label: Prints channel labels near the waveforms. Select the print interval from OFF, 200, 400, and 800 mm.</p> <p>Time print: Prints the recording start time and timestamps. Select the print interval from OFF, 200, 400, and 800 mm.</p> <p>Gauge: Prints the scale value for each channel and the end of printing.</p> <p>Annotation: Select channel information, channel message, or Data to be printed.</p> <p>Channel information: Prints information such as V/div, filter, etc.</p> <p>Message: Prints a preset message string.</p> <p>Data: Prints numeric measured values.</p> <p>Select the print interval from OFF, 200, 400, and 800 mm.</p> <p>During X-Y waveform recording Prints the scale value.</p>
Shot recording	<p>Automatically stops when the specified length is recorded after the start of measurement or after the trigger condition is met.</p> <p>Shot recording length: Continuous, 20 cm, 50 cm, 1m, or 2 m</p>
External start/stop	Shared with the GO/NOGO start terminal. Prints on a low signal. Stops printing on a high signal.
Reprint function	An arbitrary section of the recorded data saved to the memory simultaneously with realtime print can be reprinted in an arbitrary format.
Print image output	When performing reprint or fine print during T-Y waveform recording, the print image can be converted and output to a PDF file.

## Screen Image Data Output

Item	Specifications
Built-in printer	Outputs a hard copy of the screen
External printer	Outputs the screen image to an external printer via the USB PERIPHERAL terminal or the Ethernet network <sup>1</sup> . Supports ESC-P, ESC-P2, LIPS3, PCL5, BJ commands, and PostScript (only via the Ethernet network <sup>1</sup> )
Floppy disk, Zip disk, PC card, SCSI, internal HDD (optional), Network drive <sup>1</sup>	Output data format: PNG, JPEG, BMP, and PostScript

1. When the Ethernet interface option is installed (against a printer server supporting TCP/IP)

## Data Storage

Item	Specifications
History memory	Automatically holds up to 2000 pages of waveforms (depending on the memory length)
Floppy disk, Zip disk, PC card, SCSI, internal HDD (optional), Network drive <sup>1</sup>	Saves waveform data, setup data, and various data

1. When the Ethernet interface option is installed

## Acquisition Memory Backup

Item	Specifications
Batteries	4 AAA alkaline dry cells (AA/R6) (JIS, IEC model: LR6) 4 nickel hydride rechargeable batteries
Backup time (reference value)	Reference value for A1070EB (LR6JE CPT alkaline battery by Toshiba) × 4 at an ambient temperature of 23° C On models with the /M3 option           Approx. 10 h On models with the /M2 option           Approx. 15 h On models with the /M1 option           Approx. 32 h On the standard model                    Approx. 150 h
Backup function	Enable/Disable using the ON/OFF switch
Contents that are backed up	Acquisition memory waveform data (history memory data and sub waveform data of the dual capture function) and voice memo data

## Other Functions

Item	Specifications
Initialization	Resets settings to the factory default (excluding date/time setting, communication interface settings, SCSI ID number setting, language setting, time difference from the GMT, and the ON/OFF setting of the internal hard disk motor)
Auto setup	Automatically sets the voltage axis, time axis, trigger level, etc.
Action-on-trigger	Outputs screen image data, saves waveform data, activates buzzer notification, or sends e-mail messages each time a trigger occurs.
Mail transmission function <sup>1</sup>	Sends the DL750/DL750P status periodically to a specified mail address via the Ethernet network. Also sends information as an action for GO/NO-GO determination and action-on-trigger.
Calibration	Auto calibration and manual calibration available
System settings	Sets the screen color, date/time, message language, and click sound ON/OFF
Probe compensation signal output	Outputs a signal (rectangular signal of approx. 1 V <sub>P-P</sub> and approx. 1 kHz) from the probe compensation output terminal on the front panel
Overview	Shows system specifications
Self test	Memory test, key test, printer test, FDD/Zip drive/PC card drive test, internal HDD (optional) test, and SCSI test
Help function	Displays help concerning the settings (English/Japanese/Chinese switchable)
Thumbnail	Shows thumbnails of the screen image data
PROTECT key	Disables keys to prevent inadvertent errors in operation.
NUM key	Direct input of numeric values.

1. When the Ethernet interface option is installed

## 19.6 Built-in Printer

Item	Specifications
Printing system	Thermal line dot system
Paper width	DL750: 112 mm, DL750P: 210 mm
Effective printing width	DL750: 104 mm (832 dots), DL750P: 204 mm (1632 dots)
Dot density	8 dots/mm
Feeding direction resolution	DL750: For normal print: 13 dots/mm. For fine (long) print: 10 dots/mm DL750P: For normal print: 8 dots/mm. For fine (long) print: 10 dots/mm
Function	Normal print, fine print, zoom print, A4 print (DL750P only), realtime recording (DL750P only)
Maximum paper feeding speed	DL750: Approx. 10 mm/s during normal print (depends on the head temperature when normal printing is started and the print rate) DL750P: 20 mm/s

## 19.7 Storage

### Built-in Storage

#### • Floppy Disk Drive

Item	Specifications
Number of drives	1
Size	3.5 inch
Capacity	720 KB or 1.44 MB

#### • Zip Drive (DL750 Only)

Item	Specifications
Number of drives	1
Capacity	100 MB or 250 MB

#### • PC Card Interface

Item	Specifications
Number of drives	1
Maximum capacity	5 GB
Supported cards	Flash ATA memory card (PC card TYPE II) PC card type, CF card + adapter card, and HDD PC card.

For details on the compatible cards, contact your nearest YOKOGAWA dealer.

### Internal Hard Disk (Optional)

Item	Specifications
Number of drives	1
Size	2.5 inch
HDD capacity used	30 GB, FAT32, 2 partitions by factory default
File name	Supports long file names (ANK16 characters)
Function	Mount the internal HD via the SCSI port

### External Storage Interface

#### • SCSI

Item	Specifications
Standard	SCSI (Small Computer System Interface).ANSIX3.131-1986
Connector	Half pitch 50 pins
Connector pin assignment	Unbalanced (single-ended)

### USB Storage Device\*

Item	Specifications
Compatible USB mass storage devices	USB (USB Mass Storage Class) hard disk drive, MO disk drive, and flash memory storage devices

For specification details, see the next section, "USB PERIPHERAL Interface."

\* Model that can connect a USB storage device

- DL750: Check the overview screen by choosing MISC > Overview.  
If USB Storage: Yes and Soft Version: 6.02 (or later) are displayed, a USB storage device can be connected.
- DL750P: All DL750Ps can connect to a USB storage device.

## 19.8 USB PERIPHERAL Interface

Item	Specifications
Connector type	USB type A connector (receptacle)
Electrical and mechanical specifications	Conforms to USB Rev.1.1
Data rate	12 Mbps maximum
Supported keyboards* <sup>1</sup>	104 keyboard/89 keyboard (US) and 109 keyboard/89 keyboard (Japanese) conforming to USB HID Class Ver.1.1
Supported printers* <sup>1</sup>	ESC/P, ESC/P2, LIPS3, PCL5, and BJ (can be used on models that support the BJC-35V native commands) that support USB (USB Printer Class Ver.1.0)
Supported mouse* <sup>1</sup>	Mouse (with wheel) that supports USB HID Class Ver.1.1
Supported USB mass storage devices	USB (USB Mass Storage Class) hard disk drive, MO disk drive, and flash memory
Power supply	5 V, 500 mA* <sup>2</sup> (per port)
Number of ports	2

\*<sup>1</sup> For details on the compatible USB devices, contact your nearest YOKOGAWA dealer.

\*<sup>2</sup> Devices whose maximum current consumption exceeds 100 mA cannot be connected simultaneously to the two ports.

## 19.9 Auxiliary I/O Section

### Logic Input

Item	Specifications
Number of inputs	8 bits ×2
Connector type	26-pin half-pitch connector ×2
Maximum sample rate	10 MS/s
Compatible probes	Non-isolated (700986 (8 bits)) or isolated (700987 (8 bits))

### External Trigger Input

Item	Specifications
Connector type	RCA jack
Input level	TTL (0 to 5 V) input
Minimum pulse width	500 ns
Logic	Rising edge or falling edge selectable
Trigger delay time	Within 200 ns + 1 sample
Externally synchronized operation	Possible (by connecting TRIG IN and TRIG OUT on two DL750/DL750Ps)

### Trigger Output (TRIG OUT)<sup>1</sup>

Item	Specifications
Connector type	RCA jack, shared with the external sampling clock
Output level	CMOS level (0 to 5 V) output
Logic	Falls when the trigger is activated, rises after completing acquisition
Output delay time	Within 1 μs + 1 sample
Output hold time	200 ns or more

1. This terminal is also used as an external clock input terminal.

**Video Signal Output (VIDEO OUT (SVGA))**

Item	Specifications
Connector type	15-pin D-Sub receptacle
Output type	Analog RGB output
Output resolution	SVGA output 800 × 600 dots/60 Hz Vsync

**GO/NO-GO Determination I/O (GO/NO-GO)**

Item	Specifications
Connector type	Modular jack (RJ-11)
I/O level	START IN input: TTL (0 to 5 V), SW input possible GO-OUT/NOGO-OUT: CMOS (0 to 5 V)
Signal	START IN, GO-OUT, and NOGO-OUT
Compatible cable	Four-wire modular cable for telephone lines (GO/NO-GO cable (YOKOGAWA: 366973))

**External Start/Stop<sup>1</sup>**

Item	Specifications
Connector	Shared with the GO/NO-GO start terminal (used exclusively). Can be used as start/stop input when GO/NO-GO I/O is not used.
Input	TTL (0 to 5 V) or switch input Start on low, stop on high
Compatible cable	Four-wire modular cable for telephone lines (GO/NO-GO cable (YOKOGAWA: 366973))

1. The terminal is also used as a GO/NO-GO Terminal.

**COMP Output (Rectangular Signal Output for Probe Compensation)**

Item	Specifications
Output frequency	1 kHz±1%
Output amplitude	1 V±10%

**Voice Input/Output (VOICE IN/OUT/SW)<sup>1</sup>**

Item	Specification
Compatible earphone microphone	Earphone microphone with a PUSH switch (YOKOGAWA: 701951)
	Dynamic inner earphone
	Input impedance: 32 Ω
	Frequency range: 100 to 20 kHz
	Maximum input: 40 mW
	Electric condenser microphone
	Output impedance: 1.6 kΩ
	Frequency characteristics: 100 to 10 kHz
	Directional characteristics: Omnidirectional
	Code: 1.2 m, φ2.5, with 4-pin plug
	Weight: Approx. 16 g
	Earphone microphone jack input/output
	Jack: 4-pin jack
	Microphone input: Electric condenser microphone, input impedance of approx. 5 kΩ
	Earphone output: Dynamic, impedance of 32 Ω
	Switch input: 10-kΩ pull-up (3.3 V)

1. The specifications above apply to the optional earphone microphone with a PUSH switch (701951) that is sold separately. Operation of other earphone microphones are not guaranteed.



## 19.9 Auxiliary I/O Section

---

### Speaker Output<sup>1</sup>

Item	Specification
Connector	Shared with the GO/NO-GO Determination I/O (used exclusively). Can be used as speaker output when GO/NO-GO I/O is not used.
Compatible cable	External connection possible using the speaker cable (YOKOGAWA: 701952).
Compatible speaker	Impedance: 8 $\Omega$

1. The terminal is also used as a GO/NO-GO Determination I/O terminal.

### Probe Power Output (Optional)

Item	Specifications
Number of output terminals	4
Output voltage	$\pm 12$ V 2 outputs (up to a total of 800 mA)
Probes that can be used	Current probe (700937(15 A)) up to 4 probes Current probe (701930(150 A)) up to 2 probes Current probe (701931(500 A)) 1 probe Current probe (701933(30 A)) up to 2 probes

For details on the usage conditions of each probe, see "Relationship between the current being measured and probe's current consumption" on the following Web page.

<http://www.yokogawa.com/tm/probe/>

## 19.10 Computer Interface

### GP-IB<sup>1</sup>

Item	Specifications
Electrical and mechanical specifications	Conforms to IEEE St'd 488-1978 (JIS C 1901-1987)
Functional specifications	SH1, AH1, T5, L4, SR1, RL1, PP0, DC1, DT0, and C0
Protocol	Conforms to IEEE St'd 488.2-1992
Code	ISO (ASCII) code
Mode	Addressable mode
Address	Specify a talker/listener address between 0 and 30
Clear remote mode	Remote mode can be cleared using SHIFT+CLEAR TRACE (except during Local Lockout).

### Serial (RS-232)<sup>1</sup>

Item	Specifications
Connector type	9-pin D-Sub plug
Electrical Characteristics	Conforms to EIA-574 (9-pin EIA-232 (RS-232))
Connection	Point-to-point
Transmission mode	Full-duplex
Synchronization	Start-stop synchronization
Baud Rate	Select from the following rates. 1200, 2400, 4800, 9600, 19200, 38400, and 57600 If unstable, use 19200 or less.

### USB-PC Connection<sup>1</sup>

Item	Specifications
Connector type	USB type B connector (receptacle)
Electrical and mechanical specifications	Conforms to USB Rev.1.1
Data rate	12 Mbps max.
Number of ports	1
Supported service	Remote control <sup>2</sup>
PC system supported	PCs with standard USB ports running Windows 98 SE or Windows 2000. (A separate driver <sup>1</sup> is required for connecting to a PC.)

### Ethernet Connector (Optional)<sup>1</sup>

Item	Specifications
Number of communication ports	1
Electrical and mechanical specifications	Conforms to IEEE802.3
Transmission system	Ethernet (100BASE-TX/10BASE-T)
Transmission rate	100 Mbps max.
Communication protocol	TCP/IP
Supported services	FTP server, FTP client (network drive), LPR client (network printer), SMTP client (mail transmission), DHCP, DNS, Web server, and remote control
Connector type	RJ-45 connector

1. For details on the specifications, see the Communication Interface User's Manual (IM 701210-18E).
2. The DL750/DL750P can be controlled remotely from a host such as a PC. For details, see the Communication Interface User's Manual (IM 701210-18E). A separate driver is needed to use this function. The driver can be downloaded from the following Web site.  
<http://www.yokogawa.com/tm/Bu/software.htm>

## 19.11 General Specifications

Item	Specifications																																	
Standard operating conditions	Ambient temperature: 23±5° C Ambient humidity: 55±10% RH Within 1% of the rated error of the power supply voltage and frequency After a 30-minute warm-up and after calibration																																	
Recommended calibration period	1 year																																	
Warm-up time	At least 30 minutes																																	
Storage temperature	-20° C to 60° C																																	
Storage humidity	20% to 85% RH (no condensation)																																	
Storage altitude	3000 m or less																																	
Operating temperature range	5° C to 40° C																																	
Operating humidity range	20 to 85% RH (when not using the printer), 35 to 85% RH (when using the printer)																																	
Operating altitude	2000 m or less																																	
Rated supply voltage	100 to 120 VAC or 200 to 240 VAC (automatic switching)																																	
Rated supply voltage frequency	50/60 Hz																																	
Permitted supply voltage	90-132 VAC/180-264 VAC																																	
Permitted supply voltage frequency range	48 to 63 Hz																																	
Maximum power consumption	Approx. 200 VAMAX (Maximum power when the printer is OFF and 16 channels are running is 135 VA (reference value))																																	
Withstand voltage	1500 VAC for 1 minute across the power supply and earth																																	
Insulation resistance	10 MΩ or more at 500 VDC across the power supply and ground																																	
External dimensions	355 mm (W) × 250 mm (H) × 180 mm(D) (excluding the handle and other projections)																																	
Weight	DL750: Approx. 6.6 kg (only the DL750 with all options (/M3/C8/C10/P4) options, without the chart paper) Approx. 10.6 kg (DL750 + eight High-Speed 10 MS/s, 12-Bit Isolation Modules) DL750P: Approx. 7.8 kg (only the DL750P with all options (/M3/C8/C10/P4) options, without the chart paper) Approx. 11.8 kg (DL750P + eight High-Speed 10 MS/s, 12-Bit Isolation Modules) Module: Approx. 300 g (High-Speed 10 MS/s, 12-Bit Isolation Module)																																	
Instrument's cooling method	Forced air cooling. Exhaust on the left side panel and top.																																	
Battery backup	Setup parameters and clock are backed up with the internal lithium battery																																	
Battery backup Battery life	Approx. 5 years (at ambient temperature of 25° C)																																	
Fuse	Inside the power supply unit (cannot be replaced from the outside of the instrument)																																	
Standard accessories for the DL750/DL750P	<table border="0"> <tr> <td>Front panel protection cover</td> <td>1</td> <td>B8023EA</td> </tr> <tr> <td>Soft case</td> <td>1</td> <td>B9946EB</td> </tr> <tr> <td>Cover panels</td> <td>8</td> <td>B8023EN</td> </tr> <tr> <td>Power cord</td> <td>1</td> <td></td> </tr> <tr> <td>Printer roll paper (for the DL750)</td> <td>3</td> <td>B9988AE (10-m roll)</td> </tr> <tr> <td>Printer roll paper (for the DL750P)</td> <td>1</td> <td>701966 (20 m roll)</td> </tr> <tr> <td>AAA Alkaline batteries (for waveform memory backup)</td> <td>4</td> <td>A1070EB (LR6JECPT by Toshiba)</td> </tr> <tr> <td>Rubber hind feet</td> <td>1</td> <td>B9989EX(4 pieces (1 sheet))</td> </tr> <tr> <td>User's Manual</td> <td>1</td> <td></td> </tr> <tr> <td>Operation Guide</td> <td>1</td> <td></td> </tr> <tr> <td>Communication Interface User's Manual</td> <td>1</td> <td>B8023YZ (CD-ROM)</td> </tr> </table>	Front panel protection cover	1	B8023EA	Soft case	1	B9946EB	Cover panels	8	B8023EN	Power cord	1		Printer roll paper (for the DL750)	3	B9988AE (10-m roll)	Printer roll paper (for the DL750P)	1	701966 (20 m roll)	AAA Alkaline batteries (for waveform memory backup)	4	A1070EB (LR6JECPT by Toshiba)	Rubber hind feet	1	B9989EX(4 pieces (1 sheet))	User's Manual	1		Operation Guide	1		Communication Interface User's Manual	1	B8023YZ (CD-ROM)
Front panel protection cover	1	B8023EA																																
Soft case	1	B9946EB																																
Cover panels	8	B8023EN																																
Power cord	1																																	
Printer roll paper (for the DL750)	3	B9988AE (10-m roll)																																
Printer roll paper (for the DL750P)	1	701966 (20 m roll)																																
AAA Alkaline batteries (for waveform memory backup)	4	A1070EB (LR6JECPT by Toshiba)																																
Rubber hind feet	1	B9989EX(4 pieces (1 sheet))																																
User's Manual	1																																	
Operation Guide	1																																	
Communication Interface User's Manual	1	B8023YZ (CD-ROM)																																

**DC Option (DL750 Only)**

Item	Specifications
Supply format	Auto DC/AC switching (AC preferred), isolation between DC power input terminal and the DL750
Rated supply voltage	12 VDC
Permitted supply voltage	10 to 18 VDC
Power consumption	Approx. 40 VA (typical*1): When printer is OFF and two channels are used Approx. 60 VA (typical*1): When printer is OFF and eight channels are used Approx. 80 VA (typical*1): When printer is OFF and 16 channels are used
Maximum power consumption	Approx. 120 VA Max.
Standby power (during DC standby)	30 mW (typical*1, DC power consumption when power is supplied both to AC and DC power)
Voltage input protection circuit	Overcurrent detection: Breaker (15 A) Reverse connection protection: Breaker shutdown Undervoltage detection: Cut off at a voltage less than approx. 9.5 V Overvoltage detection: Cut off at a voltage greater than approx. 18 V
Withstand voltage	30 VAC for one minute between the DC power input terminal and earth terminal
Insulation resistance	10 MΩ or more at 500 VDC between the DC power terminal and earth
External dimensions	355 mm (W) × 250 mm (H) × 200 mm (D) (DL750 with the /DC option installed, excluding the handle and other projections)
Weight	Approx. 7.4 kg (only the DL750 with all options (/M3/C8/C10/P4/DC options) Approx. 9.8 kg (DL750 (with /DC option) + eight High-speed 10 MS/s, 12-Bit Isolation Modules) Weight increase by the DC power option                      Approx. 800 g
Indicator function	Indicates the status of the power supply to the DL750 using two LEDs
Accessories	The following items are added to the standard accessories. Soldering-type DC power connector (B8023WZ)

\* Same specifications as the standard model for standard operating conditions, storage temperature, storage humidity, storage altitude, operating temperature range, operating humidity range, operating altitude, and battery backup.

\*1 Typical value represents a typical or average value. It is not a warranted value.

## 19.11 General Specifications

Item	Specifications
Safety standard	<p>Complying standard EN61010-1</p> <ul style="list-style-type: none"> <li>• Installation category (overvoltage category) II<sup>1</sup></li> <li>• Measurement category II<sup>2</sup></li> <li>• Pollution degree 2<sup>3</sup></li> </ul> <p>Already certified (701210/701230/701250/701251/701255/701260/ 701261/701262/701265/701270/701271/701275/701280/700986/700987/ 701955/701956/701957/701958)</p>
Emission	<p>Complying standard EN61326-1 Class A EN61326-2-1 EN55011 Class A, Group 1 C-tick EN55011 Class A, Group 1</p> <p>Already certified (701210/701230/701250/701251/701255/701260/ 701261/701262/701265/701270/701271/701275/701280/700986/700987/ 701955/701956/701957/701958)</p> <p>EN61000-3-2 EN61000-3-3</p> <p>Cable condition</p> <ul style="list-style-type: none"> <li>• This product is a Class A (for industrial environment) product. Operation of this product in a residential area may cause radio interference in which case the user is required to correct the interference.</li> <li>• Shared external trigger/external clock input terminal Use the BNC-RCA adapter (YOKOGAWA: 366928) and a BNC cable<sup>4</sup> and attach a ferrite core (TDK: ZCAT2035-0930A, YOKOGAWA: A1190MN) on one end (DL750/DL750P side).</li> <li>• Trigger output terminal Same as the external trigger input terminal above.</li> <li>• Video signal output (VIDEO OUT (SVGA)) terminal Use a 15-pin D-Sub VGA shielded cable<sup>4</sup>.</li> <li>• GP-IB interface connector Use shielded GP-IB cables<sup>4</sup>.</li> <li>• Serial (RS-232) interface connector Use an shielded RS-232 cable<sup>4</sup> and attach a ferrite core (TDK: ZCAT2035-0930A, YOKOGAWA: A1190MN) on one end (DL750/DL750P side).</li> <li>• SCSI interface connector Use shielded SCSI cable<sup>4</sup> and attach a ferrite core (TDK: ZCAT2035-0930A, YOKOGAWA: A1190MN) on one end (DL750/DL750P side).</li> <li>• USB peripheral connector Use shielded USB cables<sup>4</sup>.</li> <li>• USB interface connector When connecting a USB keyboard or mouse using a shielded cable or when connecting to a USB printer, use shielded USB cables<sup>4</sup>.</li> <li>• GO/NO-GO I/O terminal Use a dedicated GO/NO-GO cable (YOKOGAWA: 366937) sold separately.</li> <li>• Ethernet connector Use category 5 Ethernet cables<sup>5</sup> or better cables.</li> <li>• Probes connected to modules and wiring Use twisted pair cables when connecting items other than probes to the module. Attach a ferrite core (TDK: ZCAT2035-0930A, YOKOGAWA: A1190MN) to the probes and cables that are connected to the modules. Wrap the cable around the ferrite core once.</li> <li>• Logic probe input Attach a ferrite core (TDK: ZCAT2035-0930A, YOKOGAWA: A1190MN) on one end (DL750/DL750P side) of the cable to be connected to the logic probe input terminal.</li> <li>• Current probe (700937, 701930, 701931, 701933) When connecting a current probe to the input terminal and probe power terminal of the module, attach a ferrite core (TDK: ZCAT2035-0930A, YOKOGAWA: A1190MN) on one end (DL750/DL750P side) of the two cables together.</li> <li>• Voice memo terminal Earphone microphone with a switch<sup>4</sup> (4-pin jack microphone connectable to NTT DOCOMO portable phones) (Cannot be used on the current software version that you are using.)</li> <li>• Bridge Head for the Strain Module When using the 701270, use the 701955 or the 701956; when using the 701271, use the 701957 or the 701958.</li> <li>• DC power cord Attach a ferrite core (TDK: ZCAT3035-1330A, YOKOGAWA: A1179MN) to the DC power cord.</li> </ul>

Item	Specifications
Immunity	<p>Complying standard EN61326-1 Table 2 (for use in industrial locations) EN61326-2-1</p> <p>Already certified (701210/701230/701250/701251/701255/701260/ 701261/701262/701265/701270/701271/701275/701280/700986/700987/ 701955/701956/701957/701958)</p> <ul style="list-style-type: none"> <li>Influence in the immunity environment (performance criterion A)</li> </ul> <p>Noise increase 701250: <math>\leq \pm 5</math> mV (1:1 input, 5 mV/div conversion) 701251: <math>\leq \pm 3</math> mV (1:1 input, 1 mV/div conversion) 701255: <math>\leq \pm 25</math> mV (1:1 input, 5 mV/div conversion) 701260: <math>\leq \pm 30</math> mV (1:1 input, 20 mV/div conversion) 701261/701262: <math>\leq \pm 3</math> mV 701265: <math>\leq \pm 0.05</math> mV 701270: <math>\leq \pm 100</math> <math>\mu</math>STR (when equivalent to <math>\pm 100</math> mV, gauge factor = 2, and bridge voltage = 2 V) 701271: <math>\leq \pm 100</math> <math>\mu</math>STR (when equivalent to <math>\pm 100</math> mV, gauge factor = 2, and bridge voltage = 2 V) 701275: <math>\leq \pm 3</math> mV (1:1 input, 5 mV/div conversion) 701280: Within the specifications</p> <p>Test condition 701250: 10 MS/s, envelope mode, 50 mV/div, no input filter, with the tip of the probe (700929 (10:1)) shorted 701251: 1 MS/s, envelope mode, 10 mV/div, no input filter, with the tip of the probe (700929 (10:1)) shorted 701255: 10 MS/s, envelope mode, 50 mV/div, no input filter, with the tip of the probe (701940 (10:1)) shorted 701260: 100 kS/s, envelope mode, 20 mV/div, no input filter, with the tip of the probe (700929 (10:1)) shorted 701261/701262: 100 kS/s, envelope mode, 5 mV/div, no input filter, with the end of the 3-m twisted-pair cable shorted 701265: 100 kS/s, envelope mode, 0.1 mV/div, no input filter, With the end of the 3-m twisted-pair cable shorted 701270: 100 kS/s, envelope mode, 500 <math>\mu</math>STR, gauge factor: 2.0, no input filter, 701955 bridge voltage: 2 V, 701956 bridge voltage: 10 V 701271: 100 kS/s, envelope mode, 500 <math>\mu</math>STR, gauge factor: 2.0, no input filter, 701957 bridge voltage: 2 V, 701958 bridge voltage: 10 V 701275: 100 kS/s, envelope mode, 50 mV/div, no input filter, with the tip of the probe (700929 (10:1)) shorted 701280: 25 kS/s, envelope mode, Frequency, 0.1 Hz/div, no input filter, User (<math>\pm 1</math> V, threshold level: 0 V, hysteresis: <math>\pm 1\%</math>), with the tip of the probe (700929 (10:1)) shorted</p> <p>Test Item 1. Electrostatic discharge EN61000-4-2 Air discharge: <math>\pm 8</math> kV, contact discharge: <math>\pm 4</math> kV, criteria B 2. Radiated immunity EN61000-4-3 80 MHz to 1 GHz, 1.4 GHz to 2 GHz, 10 V/m Criteria A 3. Conducted immunity EN61000-4-6 3 V, criteria A 4. Electrical fast transient/burst EN61000-4-4 Power line: <math>\pm 2</math> kV, signal line: <math>\pm 1</math> kV, criteria B 5. Power frequency magnetic field EN61000-4-8 30 A/m, 50 Hz, criteria A 6. Surge immunity EN61000-4-5 Between lines: <math>\pm 1</math> kV, common: <math>\pm 2</math> kV, criteria B 7. Voltage dip and interruption EN61000-4-11 0.5 cycle, both polarities, 100%, criteria A</p> <p>Definitions of criteria A and B</p> <ul style="list-style-type: none"> <li>Criteria A Aforementioned "Influence in the immunity environment" is met during the test.</li> <li>Criteria B This apparatus continues to operate without hang-up or falling into uncontrollable conditions during the test. No change of actual operating state or stored data is allowed.</li> </ul>

- The Overvoltage Category (Installation Category) is a value used to define the transient overvoltage condition and includes the impulse withstand voltage regulation. I applies to electrical equipment that is powered by a circuit with overvoltage control. II applies to electrical equipment that is powered by a fixed installation such as a distribution board.
- Measurement category II (CAT II) applies to measurement of electrical equipment which is supplied from fixed installations such as a wall outlet wired from a distribution board, or of the wires themselves.
- Pollution Degree: Applies to the degree of adhesion of a solid, liquid, or gas which deteriorates withstand voltage or surface resistivity. Pollution Degree 2 applies to normal indoor atmospheres (with only non-conductive pollution).
- Use cables of length 3 m or less.
- Use cables of length 30 m or less.

## 19.12 Module Specifications

### High-Speed 10 MS/s, 12-Bit Isolation Module (701250) Specifications

Item	Specifications
Standard operating conditions	Temperature: 23° C±5° C Humidity: 55%±10% RH After a 30-minute warm-up and after calibration
Effective measurement range	20 div (±10 div around 0 V, display range: 10 div, when Variable is OFF)
Number of input channels	2
Input coupling	AC, DC, and GND
Maximum sample rate	10 MS/s
Input format	Isolated unbalanced
Frequency characteristics <sup>1</sup>	(-3 dB point when sine wave of amplitude)DC to 3 MHz
Voltage-axis sensitivity setting	When using 10:1 probe attenuation: 50 mV/div to 200 V/div (1-2-5 steps) When using 1:1 probe attenuation: 5 mV/div to 20 V/div (1-2-5 steps)
Maximum input voltage (at a frequency of 1 kHz or less)	Combined with the 700929 (10:1) <sup>2</sup> : 600 V (DC+ACpeak) Combined with the 701901+701954 (1:1) <sup>4</sup> : 250 V (DC+ACpeak) Direct input or cable not complying with the safety standard <sup>6</sup> : 250 V (DC+ACpeak)
Maximum allowable common mode voltage (at a frequency of 1 kHz or less)	Working voltage of safety standard Combined with the 700929 (10:1) <sup>3</sup> or combined with the 701901+701954 (1:1) <sup>5</sup> : 400 Vrms (CAT I), 300 Vrms (CAT II) Direct input or cable not complying with the safety standard <sup>7</sup> : 42 V (DC+ACpeak) (CAT I and CAT II, 30 Vrms)
DC offset maximum selectable range	±5 div
Vertical (voltage) axis accuracy	DC accuracy <sup>1</sup> for 5 mV/div to 20 V/div: ±(0.5% of 10 div)
Input connector	BNC connector (isolated type)
Input impedance	1 MΩ±1%, approx. 35 pF
-3 dB point when AC coupled/low frequency attenuation point	10 Hz or less (1 Hz or less when using the 700929)
Common mode rejection ratio	80 dB (50/60 Hz) or more (typical <sup>8</sup> )
Residual noise level (Input section shorted)	±400 μ V or ±0.06 div, whichever is greater (typical <sup>8</sup> )
Withstand voltage	1500 Vrms for 1 minute (across each terminal and earth) (60 Hz)
Allowable transient surge voltage (instantaneous)	±2100 Vpeak (across each input terminal and earth)
Insulation resistance	500 VDC, 10 MΩ or more (across each input terminal and earth)
A/D conversion resolution	12 bit (150 LSB/div)
Temperature coefficient	Zero point: 5 mV/div to 20 V/div: ±(0.05% of 10 div)/° C (typical <sup>8</sup> ) Gain: ±(0.02% of 10 div)/° C (typical <sup>8</sup> )
Bandwidth limit	Select from OFF, 500 kHz, 50 kHz, 5 kHz, and 500 Hz Cut-off characteristics: -18 dB/OCT (typical <sup>8</sup> )
Probe attenuation setting	Voltage probe: 1:1, 10:1, 100:1, 1000:1 Current probe: 10 A: 1 V (for the 700937/701933), 100 A: 1 V (for the 701930/701931)

Item	Specifications
Compatible probes/cables	Voltage probe (10:1 safety probe): Recommended 700929 (10:1 safety probe).20 to 45 pF: For measuring 600 Vpeak or less Current probe (power can be supplied from the DL750/DL750P) 700937 (15 A), 701930 (150 A), 701931 (500 A), 701933 (30 A) High voltage differential probe (connect the GND cable provided with the probe to the DL750/ DL750P case) 700924 (1000:1, 100:1/1400Vpeak): For measuring 1400 Vpeak or less Connection cable (for high voltage 1:1) 701901 (isolated type BNC-safety alligator clip adapter ×2: For measuring 250 Vpeak or less), a separate alligator clip (701954) is required Connection cable (for low voltage 1:1) 366926 (non-isolated type BNC-alligator clip ×2: For measuring low voltage less than or equal to 42 Vpeak)

1. Value measured under standard operating conditions (section 19.11).

Combined with the 700929

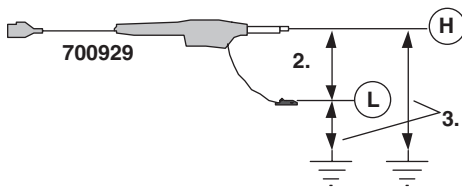

Combined with the 701901+701954

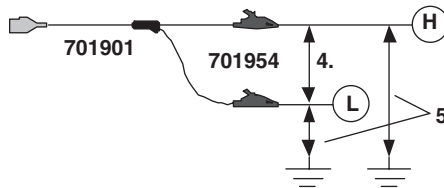

Direct input (cable not complying with the safety standard)

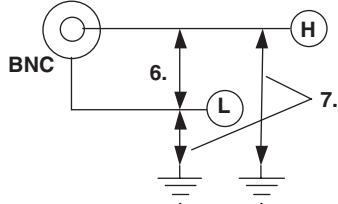

Withstand voltage: 1500 Vrms for 1 minute  
 Allowable transient surge voltage: ±2100 Vpeak  
 (between earth and input)

8. The typical value is a representative or standard value. It is not strictly warranted.



### WARNING

- Do not apply input voltage exceeding the maximum input voltage, withstand voltage, or allowable surge voltage.
- To prevent the possibility of electric shock, be sure to furnish protective earth grounding of the DL750/DL750P.
- To prevent the possibility of electric shock, be sure to fasten the module screws. Otherwise, the electrical and mechanical protection functions will not be activated.
- Avoid continuous connection under an environment in which the allowable surge voltage or higher voltage may occur.
- To prevent the possibility of electric shock, be sure to connect the GND lead of the differential probe (700924/700925) to the DL750/DL750P.



## 19.12 Module Specifications

### High-Speed High-Resolution 1 MS/s, 16-Bit Isolation Module (701251) Specifications

Item	Specifications
Standard operating conditions	Temperature: 23° C±5° C Humidity: 55%±10% RH After a 30-minute warm-up and after calibration
Effective measurement range	20 div (±10 div around 0 V, display range: 10 div, when Variable is OFF)
Number of input channels	2
Input coupling	AC, DC, and GND
Maximum sample rate	1 MS/s
Input format	Isolated unbalanced
Frequency characteristics <sup>1</sup>	(-3 dB point when a sine wave of amplitude ±3 divisions is input) For 5 mV/div to 20 V/div: DC to 300 kHz 2 mV/div, 1 mV/div: DC to 200 kHz
Voltage-axis sensitivity setting	When using 10:1 probe attenuation: 10 mV/div to 200 V/div (1-2-5 steps) When using 1:1 probe attenuation: 1 mV/div to 20 V/div (1-2-5 steps)
Maximum input voltage (at a frequency of 1 kHz or less)	Combined with the 700929 (10:1) <sup>2</sup> : 600 V (DC+ACpeak) Combined with the 701901+701954 (1:1) <sup>4</sup> : 140 V (DC+ACpeak) Direct input or cable not complying with the safety standard <sup>6</sup> : 140 V (DC+ACpeak)
Maximum allowable common mode voltage (at a frequency of 1 kHz or less)	Working voltage of safety standard Combined with the 700929 (10:1) <sup>3</sup> or combined with the 701901+701954 (1:1) <sup>5</sup> : 400 Vrms (CAT I), 300 Vrms (CAT II) Direct input or cable not complying with the safety standard <sup>7</sup> : 42 V (DC+ACpeak) (CAT I and CAT II, 30 Vrms)
DC offset maximum selectable range	±5 div
Vertical (voltage) axis accuracy	
DC accuracy <sup>1</sup>	For 5 mV/div to 20 V/div: ±(0.25% of 10 div) 2 mV/div: ±(0.3% of 10 div) 1 mV/div: ±(0.5% of 10 div)
Input connector	BNC connector (isolated type)
Input impedance	1 MΩ±1%, approx. 35 pF
-3 dB point when AC coupled low frequency attenuation point	1 Hz or less (0.1 Hz or less when using the 700929)
Common mode rejection ratio	80 dB (50/60 Hz) or more (typical <sup>8</sup> )
Residual noise level (Input section shorted)	±100 μ V or ±0.01 div, whichever is greater (typical <sup>8</sup> )
Withstand voltage	1500 Vrms for 1 minute (across each terminal and earth) (60 Hz)
Allowable transient surge voltage (instantaneous)	±2100 Vpeak (across each input terminal and earth)
Insulation resistance	500 VDC, 10 MΩ or more (across each input terminal and earth)
A/D conversion resolution	16 bit (2400 LSB/div)
Temperature coefficient	Zero point: 5 mV/div to 20 V/div: ±(0.02% of 10 div)/° C (typical <sup>8</sup> ) 2 mV/div: ±(0.05% of 10 div)/° C (typical <sup>8</sup> ) 1 mV/div: ±(0.10% of 10 div)/° C (typical <sup>8</sup> ) Gain: 1 mV/div to 20 V/div: ±(0.02% of 10 div)/° C (typical <sup>8</sup> )
Bandwidth limit	Select from OFF, 40 kHz, 4 kHz, and 400 Hz Cut-off characteristics: -12 dB/OCT (typical <sup>8</sup> )
Probe attenuation setting	Voltage probe: 1:1, 10:1, 100:1, 1000:1 Current probe: 10 A: 1 V (for the 700937/701933), 100 A: 1 V (for the 701930/701931)

Item	Specifications
Compatible probes/cables	Voltage probe (10:1 safety probe): Recommended 700929 (10:1 safety probe).20 to 45 pF: For measuring 600 Vpeak or less Current probe (power can be supplied from the DL750/DL750P) 700937 (15 A), 701930 (150 A), 701931 (500 A), 701933 (30 A) High voltage differential probe (connect the GND cable provided with the probe to the DL750/DL750P case) 700924 (1000:1, 100:1/1400 Vpeak): For measuring 1400 Vpeak or less Connection cable (for high voltage 1:1) 701901 (isolated type BNC-safety alligator clip adapter x2: For measuring 250 V peak or less), a separate alligator clip (701954) is required Connection cable (for low voltage 1:1) 366926 (non-isolated type BNC-alligator clip x2: For measuring low voltage less than or equal to 42 Vpeak)

1. Value measured under standard operating conditions (section 19.11).

Combined with the 700929

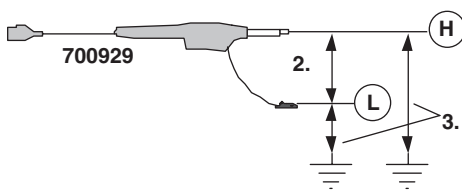

Combined with the 701901+701954

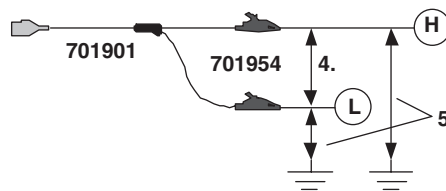

Direct input (cable not complying with the safety standard)

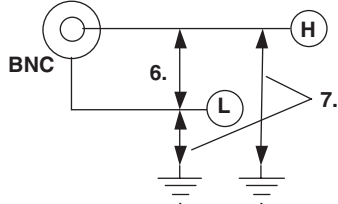

**Withstand voltage: 1500 Vrms for 1 minute**  
**Allowable transient surge voltage: ±2100 Vpeak**  
**(between earth and input)**

8. The typical value is a representative or standard value. It is not strictly warranted.



**WARNING**

- Do not apply input voltage exceeding the maximum input voltage, withstand voltage, or allowable surge voltage.
- To prevent the possibility of electric shock, be sure to furnish protective earth grounding of the DL750/DL750P.
- To prevent the possibility of electric shock, be sure to fasten the module screws. Otherwise, the electrical and mechanical protection functions will not be activated.
- Avoid continuous connection under an environment in which the allowable surge voltage or higher voltage may occur.
- To prevent the possibility of electric shock, be sure to connect the GND lead of the differential probe (700924/700925) to the DL750/DL750P.

## 19.12 Module Specifications

### High-Speed 10 MS/s, 12-Bit Non-Isolation Module (701255) Specifications

Item	Specifications
Standard operating conditions	Temperature: 23° C±5° C Humidity: 55%±10% RH After a 30-minute warm-up and after calibration
Effective measurement range	20 div (±10 div around 0 V, display range: 10 div, when Variable is OFF)
Number of input channels	2
Input coupling	AC, DC, and GND
Maximum sample rate	10 MS/s
Input format	Non-isolated, unbalanced
Frequency characteristics <sup>1</sup>	(-3 dB point when a sine wave of amplitude ±3 divisions is input) DC to 3 MHz
Voltage-axis sensitivity setting	When using 10:1 probe attenuation: 50 mV/div to 200 V/div (1-2-5 steps) When using 1:1 probe attenuation: 5 mV/div to 20 V/div (1-2-5 steps)
Maximum input voltage (at a frequency of 1 kHz or less)	Combined with 701940 (10:1) <sup>2</sup> : 600 V (DC+ACpeak) Direct input (1:1) <sup>3</sup> : 250 V (DC+ACpeak)
DC offset maximum selectable range	±5 div
Vertical (voltage) axis accuracy DC accuracy <sup>1</sup>	5 mV/div to 20 V/div: ±(0.5% of 10 div)
Input connector	BNC connector (metallic type)
Input impedance	1 MΩ±1%, approx. 35 pF
Lower -3 dB point when AC coupled	10 Hz or less (1 Hz or less when using the 701940)
Common mode rejection ratio	80 dB (50/60 Hz) or more (typical <sup>4</sup> )
Residual noise level	±400 mV or ±0.06 div, whichever is greater (typical <sup>4</sup> ) (Input section shorted)
A/D conversion resolution	12 bit (150 LSB/div)
Temperature coefficient	Zero point: 5 mV/div to 20 V/div: ±(0.05% of 10 div)/° C (typical <sup>4</sup> ) Gain: ±(0.02% of 10 div)/° C (typical <sup>4</sup> )
Bandwidth limit	Select from OFF, 500 kHz, 50 kHz, 5 kHz, and 500 Hz Cut-off characteristics: -18 dB/OCT (typical <sup>4</sup> )
Probe attenuation setting	Voltage probe: 1:1, 10:1, 100:1, 1000:1 Current probe: 10 A:1 V (for the 700937/701933), 100 A:1 V (for the 701930/701931)
Compatible probes/cables	Voltage probe (10:1 passive probe): Recommended 701940, 17 to 46 pF: For measuring 600 V (DC+ACpeak) or less Current probe (power can be supplied from the DL750/DL750P) 700937 (15A), 701930 (150A), 701931 (500 A), 701933 (30 A) High voltage differential probe (connect the GND cable provided with the probe to the DL750/DL750P case) 700924 (1000:1, 100:1/1400 Vpeak): For measuring 1400 Vpeak or less Connection cable (for low voltage 1:1) 366926 (non-isolated type BNC-alligator clip × 2: For measuring low voltage less than or equal to 42 Vpeak)

1. Value measured under standard operating conditions (section 19.11).

**Recommended:**  
Combined with the 10:1 passive probe (701940)

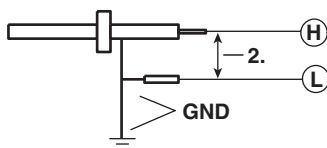

**GND is connected to the case potential.**

**Direct input**  
(When a cable that does not comply with the safety standard is connected)

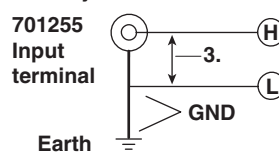

**GND is connected to the case potential.**

4. Typical value represents a typical or average value. It is not strictly warranted.

**WARNING**

- Do not apply input voltage exceeding the maximum input voltage, withstand voltage, or allowable surge voltage.
- To prevent the possibility of electric shock, be sure to furnish protective earth grounding of the DL750/DL750P.
- To prevent the possibility of electric shock, be sure to fasten the module screws.
- The module screws must be fastened for the module to function as a non-isolation module. In addition, all electrical and mechanical protection functions are activated only when the screws are fastened.
- The maximum input voltage of the module is valid only when all the screws are fastened, and the protection path of the metal BNC is secured.

## 19.12 Module Specifications

### High-Voltage 100 kS/s, 16-Bit Isolation Module (with RMS) (701260) Specifications

Item	Specifications
Standard operating conditions	Temperature: 23° C±5° C Humidity: 55%±10% RH After a 30-minute warm-up and after calibration
Effective measurement range	20 div (±10 div around 0 V, display range: 10 div, when Variable is OFF)
Number of input channels	2
Input coupling	AC, DC, GND, AC-RMS, and DC-RMS
Maximum sample rate	100 kS/s
Input format	Isolated unbalanced
Frequency characteristics <sup>1</sup>	(-3 dB point when a sine wave of amplitude ±3 divisions is input) Waveform observation mode: DC to 40 kHz RMS observation mode: DC, 40 Hz to 10 kHz
Voltage-axis sensitivity setting	When using 10:1 probe attenuation: 200 mV/div to 2000 V/div (1-2-5 steps) When using 1:1 probe attenuation: 20 mV/div to 200 V/div (1-2-5 steps)
Maximum input voltage (at a frequency of 1 kHz or less)	Combined with 700929 (10:1) <sup>2</sup> : 1000 V (DC+ACpeak) Combined with 701901(1:1)+701954 <sup>5</sup> : 850 V (DC+ACpeak) Direct input or cable not complying with the safety standard <sup>8</sup> : 850 V (DC+ACpeak)
Maximum allowable common mode voltage (at a frequency of 1 kHz or less)	Working voltage of safety standard Combined with the 700929 (across probe tip H and earth <sup>3</sup> ): 1000 Vrms (CAT II) (across probe tip L and earth <sup>4</sup> ): 400 Vrms (CAT II) Combined with 701901(1:1)+701954 (across tip H and earth <sup>6</sup> ): 700 Vrms (CAT II) (across tip L and earth <sup>7</sup> ): 400 Vrms (CAT II) Direct input or cable not complying with the safety standard <sup>9</sup> : 30 Vrms (42 VDC+ACpeak) (across the input terminal, H or L, and earth)
DC offset maximum selectable range	±5 div
Vertical (voltage) axis accuracy <sup>1</sup>	Waveform observation mode DC accuracy ±(0.25% of 10 div) RMS observation mode DC accuracy ±(1.0% of 10 div) AC accuracy (when a sine wave is input) ±(1.5% of 10 div) AC accuracy (when the crest factor is 2 or less) ±(2.0% of 10 div) AC accuracy (when the crest factor is 3 or less) ±(3.0% of 10 div) } At frequency of 40 Hz to 1 kHz
Input connector	BNC connector (isolated type)
Input impedance	1 MΩ±1%, approx. 35 pF
Lower -3 dB point when AC coupled	1 Hz or less (0.1 Hz or less when using the 700929)
Common mode rejection ratio	80 dB (50/60 Hz) or more (typical <sup>10</sup> )
Residual noise level (Input section shorted)	±1 mV or ±0.02 div, whichever is greater (typical <sup>10</sup> )
Withstand voltage	3700 Vrms for 1 minute (across each terminal and earth) (60 Hz)
Allowable transient surge voltage (instantaneous)	±5200 Vpeak (across each input terminal and earth)
Insulation resistance	500 VDC, 10 MΩ or more (across each input terminal and earth)
A/D conversion resolution	16 bit (2400 LSB/div)
Temperature coefficient (only when observing waveforms)	Zero point: ±(0.02% of 10 div)/° C (typical <sup>10</sup> ) Gain: ±(0.02% of 10 div)/° C (typical <sup>10</sup> )
Response time (only when observing RMS)	Rising (0 to 90% of 10 div): 100 ms (typical <sup>10</sup> ) Falling (100 to 10% of 10 div): 250 ms (typical <sup>10</sup> )
Bandwidth limit	Select from OFF, 10 kHz, 1 kHz, and 100 Hz Cut-off characteristics: -12 dB/OCT (typical <sup>10</sup> )
Probe attenuation setting	Voltage probe: 1:1, 10:1, 100:1, 1000:1 Current probe: 10 A:1 V (for the 700937/701933), 100 A:1 V (for the 701930/701931)

Item	Specifications
Compatible probes/cables	Connection cable (for high voltage 1:1): Recommended 1 701901 (isolated type BNC-safety alligator clip adapter × 2: For measuring 850 V (DC+ACpeak) or less), 701954 (alligator clip (dolphin type) red/black 2-piece set) is required separately Voltage probe (10:1 safety probe): Recommended 2 700929 (10:1 safety probe) .20 to 45 pF: For measuring 1000 V (DC+ACpeak) or less Current probe (power can be supplied from the DL750/DL750P) 700937 (15 A), 701930 (150 A), 701931 (500 A), 701933 (30 A)

1. Value measured under standard operating conditions (section 19.11).

Combined with the 700929

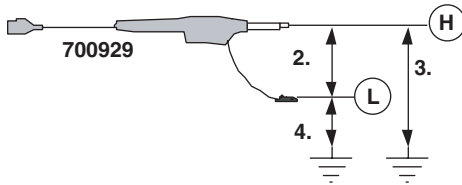

Combined with the 701901+701954

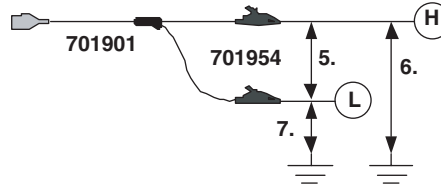

Direct input (cable not complying with the safety standard)

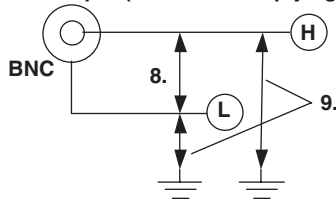

Withstand voltage: 3700 Vrms for 1 minute

10. Typical value represents a typical or average value. It is not strictly warranted.



**WARNING**

- When applying high voltage using this module, use the 1:1 safety cable (combination of 701901 and 701954) or the isolated probe (700929).
- The Measurement Category of the direct input of this module is 400 Vrms-CAT II on the low side and 700 Vrms-CAT II on the high side. Use caution because the overvoltage category differs between the low and high sides.
- Do not apply input voltage exceeding the maximum input voltage, withstand voltage, or allowable surge voltage.
- To prevent the possibility of electric shock, be sure to furnish protective earth grounding of the DL750/DL750P.
- To prevent the possibility of electric shock, be sure to fasten the module screws. Otherwise, the electrical and mechanical protection functions will not be activated.
- Avoid continuous connection under an environment in which the allowable surge voltage or higher voltage may occur.

## 19.12 Module Specifications

### Universal (Voltage/Temp.) Module (701261) Specifications Universal (Voltage/Temp.) Module (with AAF) (701262) Specifications

Item	Specifications																																							
Standard operating conditions	Temperature: 23° C±5° C Humidity: 55%±10% RH After a 30-minute warm-up and after calibration																																							
Function	Temperature (thermocouple) or voltage measurement (switchable)																																							
Effective measurement range	[Voltage measurement] 20 div (display range: 10 div)																																							
Number of input channels	2 Input coupling TC, DC, AC, and GND TC: Temperature (thermocouple) measurement DC: Voltage measurement (DC coupling) AC: Voltage measurement (AC coupling)																																							
Voltage measurement maximum sample rate	100 kHz																																							
Temperature measurement data update rate	500 Hz																																							
Input format	Isolated unbalanced																																							
Measurement range	[Voltage measurement] Voltage sensitivity: 5 mV/div to 20 V/div (1-2-5 steps) [Temperature measurement] Thermocouple: K, E, J, T, L, U, N, R, S, B, W, and Au7Fe																																							
Measurement range/accuracy <sup>1</sup>	[Voltage measurement] Voltage sensitivity: 5 mV/div to 20 V/div (1-2-5 steps) Voltage accuracy: ±(0.25% of 10 div) [Temperature measurement] <sup>2</sup>																																							
	<table border="1"> <thead> <tr> <th>Type</th> <th>Measurement Range</th> <th>Accuracy</th> </tr> </thead> <tbody> <tr> <td>K</td> <td>-200 to 1300° C</td> <td>±(0.1% of reading + 1.5° C)</td> </tr> <tr> <td>E</td> <td>-200 to 800° C</td> <td>Except ±(0.2% of reading + 1.5° C) for -200° C to 0° C</td> </tr> <tr> <td>J</td> <td>-200 to 1100° C</td> <td></td> </tr> <tr> <td>T</td> <td>-200 to 400° C</td> <td></td> </tr> <tr> <td>L</td> <td>-200 to 900° C</td> <td></td> </tr> <tr> <td>U</td> <td>-200 to 400° C</td> <td></td> </tr> <tr> <td>N</td> <td>0 to 1300° C</td> <td></td> </tr> <tr> <td>R</td> <td>0 to 1700° C</td> <td>±(0.1% of reading + 3° C)</td> </tr> <tr> <td>S</td> <td>0 to 1700° C</td> <td>Except, 0 to 200° C: ±8° C 200 to 800° C: ±5° C</td> </tr> <tr> <td>B</td> <td>0 to 1800° C</td> <td>±(0.1% of reading + 2° C) Except, 400 to 700° C: ±8° C Effective range is 400 to 1800° C</td> </tr> <tr> <td>W</td> <td>0 to 2300° C</td> <td>±(0.1% of reading + 3° C)</td> </tr> <tr> <td>Au7Fe<sup>3</sup></td> <td>0 to 300K</td> <td>0 to 50K: ±4K 50 to 300K: ±2.5K</td> </tr> </tbody> </table>	Type	Measurement Range	Accuracy	K	-200 to 1300° C	±(0.1% of reading + 1.5° C)	E	-200 to 800° C	Except ±(0.2% of reading + 1.5° C) for -200° C to 0° C	J	-200 to 1100° C		T	-200 to 400° C		L	-200 to 900° C		U	-200 to 400° C		N	0 to 1300° C		R	0 to 1700° C	±(0.1% of reading + 3° C)	S	0 to 1700° C	Except, 0 to 200° C: ±8° C 200 to 800° C: ±5° C	B	0 to 1800° C	±(0.1% of reading + 2° C) Except, 400 to 700° C: ±8° C Effective range is 400 to 1800° C	W	0 to 2300° C	±(0.1% of reading + 3° C)	Au7Fe <sup>3</sup>	0 to 300K	0 to 50K: ±4K 50 to 300K: ±2.5K
Type	Measurement Range	Accuracy																																						
K	-200 to 1300° C	±(0.1% of reading + 1.5° C)																																						
E	-200 to 800° C	Except ±(0.2% of reading + 1.5° C) for -200° C to 0° C																																						
J	-200 to 1100° C																																							
T	-200 to 400° C																																							
L	-200 to 900° C																																							
U	-200 to 400° C																																							
N	0 to 1300° C																																							
R	0 to 1700° C	±(0.1% of reading + 3° C)																																						
S	0 to 1700° C	Except, 0 to 200° C: ±8° C 200 to 800° C: ±5° C																																						
B	0 to 1800° C	±(0.1% of reading + 2° C) Except, 400 to 700° C: ±8° C Effective range is 400 to 1800° C																																						
W	0 to 2300° C	±(0.1% of reading + 3° C)																																						
Au7Fe <sup>3</sup>	0 to 300K	0 to 50K: ±4K 50 to 300K: ±2.5K																																						
Frequency characteristics <sup>1</sup>	(-3 dB point when sine wave of amplitude equivalent to ±3 div is applied) [Voltage measurement] DC to 40 kHz [Temperature measurement] DC to 100 Hz																																							
Maximum input voltage <sup>4</sup> (at a frequency of 1 kHz or less)	Both temperature and voltage input: 42 V (DC + ACpeak) (as a value that meets the safety standard) 150 V (DC + ACpeak) (maximum allowable voltage, as a value that does not damage the instrument when applied)																																							
Maximum common mode voltage <sup>5</sup> (at a frequency of 1 kHz or less)	Both temperature and voltage input: 42 V (DC+ACpeak) (CAT I and CAT II, 30 Vrms)																																							
DC offset maximum selectable range	[Voltage measurement]: ±5 div																																							
Vertical resolution	[Voltage measurement] During voltage input: 2400 LSB/div [Temperature measurement] When measuring temperature: 0.1° C																																							
Lower -3dB point when AC coupled	[Voltage measurement] 0.5 Hz or less																																							
Input connector	Binding post																																							

Item	Specifications								
Input impedance	Approx. 1 MΩ								
Common mode rejection ratio	[Voltage measurement] 80 dB (50/60 Hz) or more (typical <sup>6</sup> ) [Temperature measurement] 120 dB or more (50/60 Hz, with 2-Hz filter ON, signal source resistance of 500 Ω or less) (typical <sup>6</sup> )								
Residual noise level (Input section shorted)	[Voltage measurement]: ±100 μ V or ±0.01 div, whichever is greater (typical <sup>6</sup> )								
A/D conversion resolution	[Voltage measurement] 16 bits (2400 LSB/div)								
Temperature coefficient	[Voltage measurement] Zero point: ±(0.01% of 10 div)/° C (typical <sup>6</sup> ) Gain: ±(0.02% of 10 div)/° C (typical <sup>6</sup> )								
Reference junction compensation accuracy (when the input terminal temperature is balanced)	K, E, J, T, L, U, N: ±1° C R, S, B, W: ±1.5° C Au7Fe: ±1K								
Bandwidth limit	[Temperature measurement] (Digital filter + analog filter) Select from OFF, 30 Hz, 8 Hz, and 2 Hz + 150 Hz secondary analog filter [Voltage measurement] Select from OFF, AUTO, 4 kHz, 400 Hz, or 40 Hz. Cutoff characteristics: -12 dB/OCT (typical <sup>6</sup> , setting other than AUTO) Cutoff frequency (fc) when set to AUTO (701262 only)								
	<table border="1"> <thead> <tr> <th>Sample Rate</th> <th>Cutoff Frequency (fc)</th> </tr> </thead> <tbody> <tr> <td>100 kHz or higher</td> <td>40 kHz</td> </tr> <tr> <td>100 Hz to 50 kHz</td> <td>40% of the sample rate</td> </tr> <tr> <td>50 Hz or less</td> <td>20 Hz</td> </tr> </tbody> </table>	Sample Rate	Cutoff Frequency (fc)	100 kHz or higher	40 kHz	100 Hz to 50 kHz	40% of the sample rate	50 Hz or less	20 Hz
Sample Rate	Cutoff Frequency (fc)								
100 kHz or higher	40 kHz								
100 Hz to 50 kHz	40% of the sample rate								
50 Hz or less	20 Hz								

Cutoff characteristics for AUTO: -65 dB at 2 × fc (typical<sup>6</sup>)

Table of cutoff frequency characteristics of the anti-aliasing filter (AAF)

When the filter is set to Auto, the anti-aliasing filter and low-pass filter are automatically set according to the sample rate.

Sample Rate	AAF	Low-Pass Filter
100 kS/s	40 kHz	OFF
50 kS/s	20 kHz	OFF
20 kS/s	8 kHz	OFF
10 kS/s	4 kHz	4 kHz
5 kS/s	2 kHz	4 kHz
2 kS/s	800 Hz	4 kHz
1 kS/s	400 Hz	400 Hz
500 S/s	200 Hz	400 Hz
200 S/s	80 Hz	400 Hz
100 S/s	40 Hz	40 Hz
50 S/s	20 Hz	40 Hz
20 S/s to 5 S/s	20 Hz	40 Hz
2 S/s or less	20 Hz	40 Hz
Ext sample	40 kHz	OFF

- Value measured under standard operating conditions (section 19.11).
- Does not include the reference junction temperature compensation accuracy.
- This module supports Au7Fe with 0.07% metal content with respect to gold.

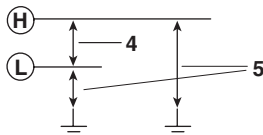

- Typical value represents a typical or average value. It is not strictly warranted.



---

### **WARNING**

- Do not apply input voltage exceeding the maximum input voltage or allowable common mode input voltage.
  - To prevent the possibility of electric shock, be sure to furnish protective earth grounding of the DL750/DL750P.
  - To prevent the possibility of electric shock, be sure to fasten the module screws. Otherwise, the electrical and mechanical protection functions will not be activated.
-

## Temperature, High Precision Voltage Isolation Module (701265) Specifications

Item	Specifications	
Standard operating conditions	Temperature: 23° C±5° C Humidity: 55%±10% RH After a 30-minute warm-up and after calibration	
Function	Temperature (thermocouple) or voltage measurement (switchable)	
Number of input channels	2	
Input coupling	TC, DC, and GND TC: Temperature (thermocouple) measurement DC: Voltage measurement (DC coupling)	
Data update rate	500 Hz	
Input format	Isolated unbalanced	
Measurement range	[Voltage measurement]	Voltage sensitivity: 100 μ V/div to 10 V/div (1-2-5 steps)
	[Temperature measurement]	TC: K, E, J, T, L, U, N, R, S, B, W, and Au7Fe
Measurement range/accuracy <sup>1</sup>	[Voltage measurement]	Voltage sensitivity: 100 μ V/div to 10 V/div (1-2-5 steps) Voltage accuracy: ±(0.08% of 10 div + 2 μ V)
	[Temperature measurement] <sup>2</sup>	
	<b>Type</b>	<b>Measurement Range</b>
	K	–200 to 1300° C
	E	–200 to 800° C
	J	–200 to 1100° C
	T	–200 to 400° C
	L	–200 to 900° C
	U	–200 to 400° C
	N	0 to 1300° C
	R	0 to 1700° C
	S	0 to 1700° C
	B	0 to 1800° C
	W	0 to 2300° C
	Au7Fe <sup>3</sup>	0 to 300 K
		Accuracy
		±(0.1% of reading+1.5° C)
		However, for –200° C to 0° C:
		±(0.2% of reading+1.5° C)
		±(0.1% of reading+3° C)
		However, for 0 to 200° C: ±8° C:
		200 to 800° C: ±5° C
		±(0.1% of reading+2° C)
		However for 400 to 700° C: ±8° C
		Effective range is 400 to 1800° C
		±(0.1% of reading+3° C)
		0 to 50K: ±4 K
		50 to 300K: ±2.5 K
Frequency characteristics <sup>1</sup>	(–3 dB point when a sine wave of amplitude of ±3 divisions is input)	
	[Voltage measurement]:	DC to 100 Hz
	[Temperature measurement]:	DC to 100 Hz
Maximum input voltage <sup>4</sup> (at a frequency of 1 kHz or less)	For both temperature and voltage input: 42 V (DC+ACpeak)	
Maximum common mode voltage <sup>5</sup> (at a frequency of 1 kHz or less)	For both temperature and voltage input: 42 V (DC+ACpeak) (CAT I and CAT II, 30 Vrms)	
DC offset maximum selectable range	[Temperature measurement]: ±5 div	
Vertical Resolution	[Voltage measurement]:	When applying voltage: 2400 LSB/div
	[Temperature measurement]:	When measuring temperature: 0.1° C
Input connector	Binding post	
Input impedance	Approx. 1 MΩ	
Common mode rejection ratio	[Voltage measurement]:	80 dB (50/60 Hz) or more (typical <sup>6</sup> )
	[Temperature measurement]:	120 dB or more (50/60 Hz, with 2-Hz filter ON, signal source resistance of 500 Ω or less) (typical <sup>6</sup> )
Residual noise level (input section shorted)	[Voltage measurement]: ±4 μ V or ±0.01 div, whichever is greater (typical <sup>6</sup> )	
A/D conversion resolution	[Voltage measurement]: 16 bits (2400 LSB/div)	
	20 div (±10 div around 0 V, display range: 10 div, when Variable is OFF)	
Temperature coefficient	Zero point:	±(0.01% of 10 div)/° C + 0.05 mV/° C (typical <sup>6</sup> )
[Voltage measurement]	Gain:	±(0.02% of 10 div)/° C (typical <sup>6</sup> )

## 19.12 Module Specifications

Item	Specifications
Reference junction compensation accuracy (when the input terminal temperature is balanced)	K, E, J, T, L, U, and N: $\pm 1^{\circ}\text{C}$ R, S, B, and W: $\pm 1.5^{\circ}\text{C}$ Au7Fe: $\pm 1\text{ K}$
Bandwidth limit (digital filter)	Select from OFF, 30 Hz, 8 Hz, and 2 Hz
Input bias current	20 nA or less The zero point appears to be offset when the input is open due to the effects of bias current on this module. However, this is not a malfunction. Connect the input to the object to be measured.

1. Value measured under standard operating conditions (section 19.11).
2. Does not include the reference junction temperature compensation accuracy.
3. This module supports Au7Fe with 0.07% metal content with respect to gold.

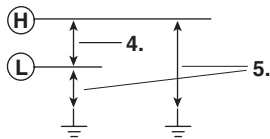

6. The typical value is a representative or standard value. It is not strictly warranted.



### WARNING

- Do not apply input voltage exceeding the maximum input voltage or allowable common mode input voltage.
- To prevent the possibility of electric shock, be sure to furnish protective earth grounding of the DL750/DL750P.
- To prevent the possibility of electric shock, be sure to fasten the module screws. Otherwise, the electrical and mechanical protection functions will not be activated.

**Strain Module (NDIS) (701270) Specifications**

Item	Specifications																																
Standard operating conditions	Temperature: 23° C±5° C Humidity: 55%±10% RH After a 30-minute warm-up and after calibration and auto balance																																
Effective measurement range	–FS to +FS (set using upper and lower limits)																																
Number of input channels	2																																
Maximum sample rate	100 kS/s																																
Input format	DC bridge (auto balancing), balanced differential input, and isolated																																
Auto balance type	Electronic auto balance																																
Auto balance range	±10000 μ STR (1 gauge method)																																
Bridge voltage	Select from 2 V, 5 V, and 10 V.																																
Gauge resistance	120 Ω to 1000 Ω (bridge voltage: 2 V) 350 Ω to 1000 Ω (bridge voltage: 2 V, 5 V, and 10 V)																																
Gauge factor	1.90 to 2.20 (set in 0.01 steps)																																
Frequency characteristics <sup>1</sup>	(–3 dB point when a sine wave of amplitude ±3 divisions is input) DC to 20 kHz																																
mV/V range support	Supports the strain gauge transducer unit system. mV/V range = 0.5×(μ STR range/1000)																																
Measurement range (FS) and measurement range	<table border="1"> <thead> <tr> <th colspan="2">When using STR range</th> </tr> <tr> <th>Measurement Range (FS)</th> <th>Measurement Range</th> </tr> </thead> <tbody> <tr> <td>500 μ STR</td> <td>–500 μ STR to +500 μ STR</td> </tr> <tr> <td>1000 μ STR</td> <td>–1000 μ STR to +1000 μ STR</td> </tr> <tr> <td>2000 μ STR</td> <td>–2000 μ STR to +2000 μ STR</td> </tr> <tr> <td>5000 μ STR</td> <td>–5000 μ STR to +5000 μ STR</td> </tr> <tr> <td>10000 μ STR</td> <td>–10000 μ STR to +10000 μ STR</td> </tr> <tr> <td>20000 μ STR</td> <td>–20000 μ STR to +20000 μ STR</td> </tr> </tbody> </table> <table border="1"> <thead> <tr> <th colspan="2">When using mV/V range</th> </tr> <tr> <th>Measurement Range (FS)</th> <th>Measurement Range</th> </tr> </thead> <tbody> <tr> <td>0.25 mV/V</td> <td>–0.25 mV/V to +0.25 mV/V</td> </tr> <tr> <td>0.5 mV/V</td> <td>–0.5 mV/V to +0.5 mV/V</td> </tr> <tr> <td>1 mV/V</td> <td>–1 mV/V to +1 mV/V</td> </tr> <tr> <td>2.5 mV/V</td> <td>–2.5 mV/V to +2.5 mV/V</td> </tr> <tr> <td>5 mV/V</td> <td>–5 mV/V to +5 mV/V</td> </tr> <tr> <td>10 mV/V</td> <td>–10 mV/V to +10 mV/V</td> </tr> </tbody> </table>	When using STR range		Measurement Range (FS)	Measurement Range	500 μ STR	–500 μ STR to +500 μ STR	1000 μ STR	–1000 μ STR to +1000 μ STR	2000 μ STR	–2000 μ STR to +2000 μ STR	5000 μ STR	–5000 μ STR to +5000 μ STR	10000 μ STR	–10000 μ STR to +10000 μ STR	20000 μ STR	–20000 μ STR to +20000 μ STR	When using mV/V range		Measurement Range (FS)	Measurement Range	0.25 mV/V	–0.25 mV/V to +0.25 mV/V	0.5 mV/V	–0.5 mV/V to +0.5 mV/V	1 mV/V	–1 mV/V to +1 mV/V	2.5 mV/V	–2.5 mV/V to +2.5 mV/V	5 mV/V	–5 mV/V to +5 mV/V	10 mV/V	–10 mV/V to +10 mV/V
When using STR range																																	
Measurement Range (FS)	Measurement Range																																
500 μ STR	–500 μ STR to +500 μ STR																																
1000 μ STR	–1000 μ STR to +1000 μ STR																																
2000 μ STR	–2000 μ STR to +2000 μ STR																																
5000 μ STR	–5000 μ STR to +5000 μ STR																																
10000 μ STR	–10000 μ STR to +10000 μ STR																																
20000 μ STR	–20000 μ STR to +20000 μ STR																																
When using mV/V range																																	
Measurement Range (FS)	Measurement Range																																
0.25 mV/V	–0.25 mV/V to +0.25 mV/V																																
0.5 mV/V	–0.5 mV/V to +0.5 mV/V																																
1 mV/V	–1 mV/V to +1 mV/V																																
2.5 mV/V	–2.5 mV/V to +2.5 mV/V																																
5 mV/V	–5 mV/V to +5 mV/V																																
10 mV/V	–10 mV/V to +10 mV/V																																
DC accuracy <sup>1</sup>	±(0.5% of FS+5 μ STR)																																
Maximum input voltage	Between Input+ and Input– 10 V (DC+ACpeak) (At 1 kHz or less)																																
Maximum allowable common mode voltage (At 1 kHz or less)	Between each terminal and earth ground 42 V (DC+ACpeak) (CAT I and CAT II, 30 Vrms)																																
Input connector	NDIS connector (Recommended by JSNDI (The Japanese Society for Non-destructive Inspection))																																
Common mode rejection ratio	80 dB (50/60 Hz) or more (typical <sup>2</sup> )																																
A/D conversion resolution	16 bit (4800 LSB/div: Upper = +FS, Lower = –FS)																																
Temperature coefficient	Zero point: ±5 μ STR/° C (typical <sup>2</sup> ) Gain: ±(0.02% of FS)/° C (typical <sup>2</sup> )																																
Bandwidth limit	Select from OFF, 1 kHz, 100 Hz, and 10 Hz Cutoff characteristics: –12 dB/OCT (typical <sup>2</sup> )																																
Function	mV/V support. Supports the strain gauge transducer unit system.																																
Standard accessories	NDIS connector (for external connection: PRC03-12A10-7M10.5 by Tajimi) A1002JC: 2 pieces																																
Compatible accessories (sold separately)	Recommended bridge head 701955 (NDIS 120 Ω, enhanced shield version, comes with a 5-m cable) Recommended bridge head 701956 (NDIS 350 Ω, enhanced shield version, comes with a 5-m cable)																																

## 19.12 Module Specifications

Item	Specifications
Precautions	<ul style="list-style-type: none"> <li>Highly sensitive measurements are made in the <math>\mu V</math> level in strain measurements. Therefore, take measures against noise at the strain sensor perimeter, bridge head, and cable wiring.</li> <li>Depending on the noise environment, an error may result in the balance. Check the influence before making measurements.</li> <li>The bridge head specified by YOKOGAWA has high noise resistance.</li> <li>Some of the strain gauge sensors and bridge heads made by other manufacturers do not have sensing wires connected. (No such problems with bridge heads made by YOKOGAWA.) If such products are used, an error may result in the bridge voltage leading to measurement errors, because sensing does not work effectively. If possible, it is desirable that sensing be done very close to the bridge. However, if this is not possible, use the NDIS conversion cable (DV450-001) that is sold separately by YOKOGAWA. Outline specifications of the DV450-001: Sensing cable, NDIS male-female, 30 cm in length, insert it as close to the bridge as possible</li> <li>The connector shell is connected to the case potential.</li> <li>When a bridge head (701955 or 701956) is used, the connector shell, cable shield, and the bridge head case are all connected to the case potential of the DL750/DL750P.</li> <li>When a bridge head (701955 or 701956) is used, the floating GND is connected to the bridge head case inside the bridge head.</li> <li>Be sure to execute balancing again when you change the range or the bridge voltage.</li> </ul>

- Value measured under standard operating conditions (section 19.11).
- Typical value represents a typical or average value. It is not strictly warranted.

### Module front View

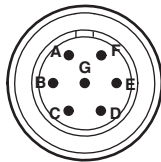

- A: Bridge+ (positive bridge voltage)
- B: Input- (negative measurement signal)
- C: Bridge- (negative bridge voltage)
- D: Input+ (positive measurement signal)
- E: Floating common
- F: Sense+ (positive bridge voltage sensing)
- G: Sense- (positive bridge voltage sensing)

The connector shell is connected to the case potential.



### WARNING

- Do not apply input voltage exceeding the maximum input voltage, withstand voltage, or allowable surge voltage.
- To prevent the possibility of electric shock, be sure to furnish protective earth grounding of the DL750/DL750P.
- To prevent the possibility of electric shock, be sure to fasten the module screws. Otherwise, the electrical and mechanical protection functions will not be activated.
- Avoid continuous connection under an environment in which the allowable surge voltage may occur.

## Strain Module (DSUB, Shunt-Cal) (701271) Specifications

Item	Specifications																																
Standard operating conditions	Temperature: 23° C±5° C Humidity: 55%±10% RH After a 30-minute warm-up and after calibration and auto balance																																
Effective measurement range	–FS to +FS (set using upper and lower limits)																																
Number of input channels	2																																
Maximum sample rate	100 kS/s																																
Input format	DC bridge (auto balancing), balanced differential input, and isolated																																
Auto balance type	Electronic auto balance																																
Auto balance range	±10000 μ STR (1 gauge method)																																
Bridge voltage	Select from 2 V, 5 V, and 10 V.																																
Gauge resistance	120 Ω to 1000 Ω (bridge voltage: 2 V) 350 Ω to 1000 Ω (bridge voltage: 2 V, 5 V, and 10 V)																																
Gauge factor	1.90 to 2.20 (set in 0.01 steps)																																
Frequency characteristics <sup>1</sup>	(–3 dB point when a sine wave of amplitude ±3 divisions is input) DC to 20 kHz																																
mV/V range support	Supports the strain gauge transducer unit system. mV/V range = 0.5×(μ STR range/1000)																																
Measurement range (FS) and measurement range	<table border="1"> <thead> <tr> <th colspan="2">When using STR range</th> </tr> <tr> <th>Measurement Range (FS)</th> <th>Measurement Range</th> </tr> </thead> <tbody> <tr> <td>500 μ STR</td> <td>–500 μ STR to +500 μ STR</td> </tr> <tr> <td>1000 μ STR</td> <td>–1000 μ STR to +1000 μ STR</td> </tr> <tr> <td>2000 μ STR</td> <td>–2000 μ STR to +2000 μ STR</td> </tr> <tr> <td>5000 μ STR</td> <td>–5000 μ STR to +5000 μ STR</td> </tr> <tr> <td>10000 μ STR</td> <td>–10000 μ STR to +10000 μ STR</td> </tr> <tr> <td>20000 μ STR</td> <td>–20000 μ STR to +20000 μ STR</td> </tr> </tbody> </table> <table border="1"> <thead> <tr> <th colspan="2">When using mV/V range</th> </tr> <tr> <th>Measurement Range (FS)</th> <th>Measurement Range</th> </tr> </thead> <tbody> <tr> <td>0.25 mV/V</td> <td>–0.25mV/V to +0.25 mV/V</td> </tr> <tr> <td>0.5 mV/V</td> <td>–0.5mV/V to +0.5 mV/V</td> </tr> <tr> <td>1 mV/V</td> <td>–1mV/V to +1 mV/V</td> </tr> <tr> <td>2.5 mV/V</td> <td>–2.5mV/V to +2.5 mV/V</td> </tr> <tr> <td>5 mV/V</td> <td>–5mV/V to +5 mV/V</td> </tr> <tr> <td>10 mV/V</td> <td>–10mV/V to +10 mV/V</td> </tr> </tbody> </table>	When using STR range		Measurement Range (FS)	Measurement Range	500 μ STR	–500 μ STR to +500 μ STR	1000 μ STR	–1000 μ STR to +1000 μ STR	2000 μ STR	–2000 μ STR to +2000 μ STR	5000 μ STR	–5000 μ STR to +5000 μ STR	10000 μ STR	–10000 μ STR to +10000 μ STR	20000 μ STR	–20000 μ STR to +20000 μ STR	When using mV/V range		Measurement Range (FS)	Measurement Range	0.25 mV/V	–0.25mV/V to +0.25 mV/V	0.5 mV/V	–0.5mV/V to +0.5 mV/V	1 mV/V	–1mV/V to +1 mV/V	2.5 mV/V	–2.5mV/V to +2.5 mV/V	5 mV/V	–5mV/V to +5 mV/V	10 mV/V	–10mV/V to +10 mV/V
When using STR range																																	
Measurement Range (FS)	Measurement Range																																
500 μ STR	–500 μ STR to +500 μ STR																																
1000 μ STR	–1000 μ STR to +1000 μ STR																																
2000 μ STR	–2000 μ STR to +2000 μ STR																																
5000 μ STR	–5000 μ STR to +5000 μ STR																																
10000 μ STR	–10000 μ STR to +10000 μ STR																																
20000 μ STR	–20000 μ STR to +20000 μ STR																																
When using mV/V range																																	
Measurement Range (FS)	Measurement Range																																
0.25 mV/V	–0.25mV/V to +0.25 mV/V																																
0.5 mV/V	–0.5mV/V to +0.5 mV/V																																
1 mV/V	–1mV/V to +1 mV/V																																
2.5 mV/V	–2.5mV/V to +2.5 mV/V																																
5 mV/V	–5mV/V to +5 mV/V																																
10 mV/V	–10mV/V to +10 mV/V																																
DC accuracy <sup>1</sup>	±(0.5% of FS+5 μ STR)																																
Maximum input voltage	Between Input+ and Input– 10 V (DC+ACpeak) (At 1 kHz or less)																																
Maximum allowable common mode voltage (At 1 kHz or less)	Between each terminal and earth ground 42 V (DC+ACpeak) (CAT I and CAT II, 30 Vrms)																																
Input connector	9-pin D-Sub connector (female)																																
Common mode rejection ratio	80 dB (50/60 Hz) or more (typical <sup>2</sup> )																																
A/D conversion resolution	16 bit (4800 LSB/div: Upper = +FS, Lower = –FS)																																
Temperature coefficient	Zero point: ±5 μ STR/° C (typical <sup>2</sup> ) Gain: ±(0.02% of FS)/° C (typical <sup>2</sup> )																																
Bandwidth limit	Select from OFF, 1 kHz, 100 Hz, and 10 Hz Cutoff characteristics: –12 dB/OCT (typical <sup>2</sup> )																																
Function	mV/V support. Supports the strain gauge transducer unit system. Shunt calibration support. Built-in shunt calibration relay (1 gauge method).																																
Standard accessories	Connector shell set for soldering A1520JD (9-pin D-Sub): 2 pieces, A1618JD (connector shell): 2 pieces																																
Compatible accessories (sold separately)	Recommended bridge head 701957 (D-Sub 120 Ω, shunt-Cal, comes with a 5-m cable) Recommended bridge head 701958 (D-Sub 350 Ω, shunt-Cal, comes with a 5-m cable)																																

## 19.12 Module Specifications

Item	Specifications
Precautions	<ul style="list-style-type: none"> <li>Highly sensitive measurements are made in the <math>\mu V</math> level in strain measurements. Therefore, take measures against noise at the strain sensor perimeter, bridge head, and cable wiring.</li> <li>Depending on the noise environment, an error may result in the balance. Check the influence before making measurements.</li> <li>The bridge head specified by YOKOGAWA has high noise resistance.</li> <li>When executing shunt calibration, be sure to calculate the shunt resistance in advance, and execute it in a range so that the measured values do not exceed the range even when the shunt resistance is ON.</li> <li>Some of the strain gauge sensors and bridge heads made by other manufacturers do not have sensing wires connected. (No such problems with bridge heads made by YOKOGAWA.) If such products are used, an error may result in the bridge voltage leading to measurement errors, because sensing does not work effectively. Perform sensing as close to the bridge head as possible. (There is no conversion cable for sensing on D-Sub connector types.)</li> <li>The connector shell is connected to the case potential.</li> <li>When a bridge head (701957 or 701958) is used, the connector shell, cable shield, and the bridge head case are all connected to the case potential of the DL750/DL750P.</li> <li>When a bridge head (701957 or 701958) is used, the floating GND is connected to the bridge head case inside the bridge head.</li> <li>Be sure to execute balancing again when you change the range or the bridge voltage.</li> </ul>

- Value measured under standard operating conditions (section 19.11).
- Typical value represents a typical or average value. It is not strictly warranted.

### Module front View

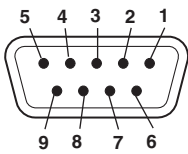

- 1: Floating common
- 2: Sense- (positive bridge voltage sensing)
- 3: Shuntcal- (negative shunt signal)
- 4: Shuntcal+ (positive shunt signal)
- 5: Sense+ (positive bridge voltage sensing)
- 6: Bridge- (negative bridge voltage)
- 7: Input- (negative measurement signal)
- 8: Input+ (positive measurement signal)
- 9: Bridge+ (positive bridge voltage)



### WARNING

- Do not apply input voltage exceeding the maximum input voltage, withstand voltage, or allowable surge voltage.
- To prevent the possibility of electric shock, be sure to furnish protective earth grounding of the DL750/DL750P.
- To prevent the possibility of electric shock, be sure to fasten the module screws. Otherwise, the electrical and mechanical protection functions will not be activated.
- Avoid continuous connection under an environment in which the allowable surge voltage may occur.

**Acceleration/Voltage Module (with AAF) (701275) Specifications**

Item	Specifications
Standard operating conditions	Temperature: 23° C±5° C Humidity: 55%±10% RH After a 30-minute warm-up and after calibration
Effective measurement range	20 div (display range: 10 div)
Number of input channels	2
Input coupling settings	AC, DC, ACCL (acceleration), and GND
Maximum sample rate	100 kS/s
Input format	Isolated unbalanced
Frequency characteristics <sup>1</sup>	(-3 dB point when a sine wave of amplitude ±3 divisions is input) Waveform measurement mode: DC to 40 kHz Acceleration measurement mode: 0.4 Hz to 40 kHz
Voltage-axis sensitivity setting	When using 1:1 probe attenuation: 5 mV/div to 10 V/div (1-2-5 steps) When using 10:1 probe attenuation: 50 mV/div to 100 V/div (1-2-5 steps) (combined with the recommended probe 701940) Acceleration (±5 V = ×1 range): ×0.1 to ×1 to ×100 (in 1-2-5 steps)
Maximum input voltage (at a frequency of 1 kHz or less)	42 V (DC+Acpeak) <sup>2</sup>
Maximum allowable common mode voltage (at a frequency of 1 kHz or less)	Working voltage of safety standard 30 Vrms (CAT I and CAT II) <sup>3</sup>
DC offset Maximum selectable range	±5 div
Vertical (voltage) axis accuracy	Waveform measurement mode: DC accuracy: ±(0.25% of 10 div) Acceleration measurement mode: ±(0.5% of 10 div) at 1 kHz
Input connector	Metal BNC connector
Input impedance -3dB point when AC coupled frequency attenuation point	1 MΩ ±1%, approx. 35 pF Low 0.4 Hz or less (0.04 Hz or less when using the 701940) (typical <sup>4</sup> )
Common mode rejection ratio	80 dB (50/60 Hz) or more (typical <sup>4</sup> )
Residual noise level (Input section shorted)	±100 μV or ±0.01 div, whichever is greater (typical <sup>4</sup> )
A/D conversion resolution	16 bits (2400 LSB/div)
Temperature coefficient	When in waveform measurement mode (excluding AUTO filter) Zero point: ±(0.02% of 10 div)/° C (typical <sup>4</sup> ) Gain: ±(0.02% of 10 div)/° C (typical <sup>4</sup> )
Bandwidth limit	Select from OFF, Auto, 4 KHz, 400 Hz, and 40 Hz Cutoff characteristics: -12 dB/OCT (typical <sup>4</sup> , excluding AUTO) Cutoff frequency (fc) when set to AUTO Sample rate of 100 kHz or higher: fc = 40 kHz Sample rate of 100 Hz to 50 kHz: fc = 40% of the sampling rate Sample rate of 50 Hz or less: fc = 20 Hz Cutoff characteristics when set to AUTO: -65 at 2×fc (typical <sup>4</sup> )
Probe attenuation setting	Voltage probe 1:1, 10:1, 100:1, or 1000:1 Current probe 10 A:1 V (for the 700937/701933), 100 A:1 V (for the 701930/701931)
Compatible probes/cables	Connection cable (for low voltage 1:1) 366926 (non-isolated type BNC-alligator clip × 2: For measuring low voltage less than or equal to 42 Vpeak) Voltage probe (10:1 passive probe) 701940 17 to 46 pF: For measuring 600 V (DC+ACpeak) or less Current probe (power can be supplied from the DL750/DL750P) 700937 (15 A), 701930 (150 A), 701931 (500 A), 701933 (30 A)
Sensor supply current (voltage)	OFF or 4 mA±10% (approx. 22 VDC)
Applicable acceleration sensor	Built-in amplifier type Kistler Instrument Corporation: Piezotron, PCB Piezotronics Incorporated: ICP, ENDEVCO Corporation: ISOTRON, etc.



## 19.12 Module Specifications

Item	Specifications
------	----------------

Table of Cutoff Frequency Characteristics of the Anti-Aliasing Filter (AAF)

When the filter is set to Auto, the anti-aliasing filter and low-pass filter are automatically set according to the sample rate.

Sample Rate	AAF	Low-pass filter
100 kS/s	40 kHz	OFF
50 kS/s	20 kHz	OFF
20 kS/s	8 kHz	OFF
10 kS/s	4 kHz	4 kHz
5 kS/s	2 kHz	4 kHz
2 kS/s	800 Hz	4 kHz
1 kS/s	400 Hz	400 Hz
500 S/s	200 Hz	400 Hz
200 S/s	80 Hz	400 Hz
100 S/s	40 Hz	40 Hz
50 S/s	20 Hz	40 Hz
20 S/s to 5 S/s	20 Hz	40 Hz
2 S/s or less	20 Hz	40 Hz
Ext sample	40 kHz	OFF

1 Value measured under standard operating conditions (section 19.11).

Combined with the 10:1 passive probe (701940)

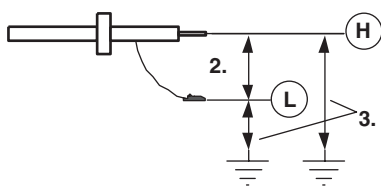

Direct input (cable not complying with the safety standard)

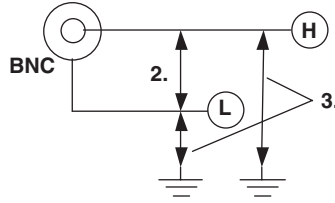

4 Typical value represents a typical or average value. It is not strictly warranted.



### WARNING

- Do not apply input voltage exceeding the maximum input voltage, withstand voltage, or allowable surge voltage.
- To prevent the possibility of electric shock, be sure to furnish protective earth grounding of the DL750/DL750P.
- To prevent the possibility of electric shock, be sure to fasten the module screws. Otherwise, the electrical and mechanical protection functions will not be activated.
- Avoid continuous connection under an environment in which the allowable surge voltage may occur.

## Frequency Module (701280) Specifications

Item	Specifications
Standard operating conditions	Temperature: 23° C±5° C Humidity: 55% ±10% RH After the warm-up time of 30 minutes has elapsed
Measurement function	Frequency, RPMs, RPSs, period, duty cycle, power supply frequency, pulse width, pulse integration, and velocity
Effective measurement range	20 div (display range: 10 div)
Number of input channels	2
Data update rate	25 kHz (40 μ s)
Output delay time	Up to 2 computation periods
Input format	Isolated unbalanced
Input connector	BNC connector (isolated type)
Maximum input voltage	Module only (when 1:1 cable is connected, across input terminals H and L): 42 V (DC+ACpeak) <sup>4</sup> Combined with the 700929 (10:1) (across the probe tips, H and L <sup>3</sup> ): 420 V (DC+ACpeak) <sup>2</sup>
Maximum allowable common mode voltage	Working voltage of safety standard Module only (when 1:1 cable is connected, across input terminal L and earth) 30 Vrms (CAT I and CAT II) <sup>5</sup> Combined with the 700929 (10:1) (across probe tip H or L and earth) 300 Vrms (CAT I and CAT II) <sup>3</sup>
Insulation resistance	500 VDC, 10 MΩ or more (across each input terminal and earth)
Minimum measurement resolution	50 ns
Measured data resolution	16 bits (2400 LSB/div)
Measurement accuracy <sup>1</sup>	<ul style="list-style-type: none"> <li>• <b>When in frequency, RPM, RPS, or velocity measurement mode<sup>6</sup></b> Measurement accuracy is specified according to the measurement range and input frequency [Definition of measurement accuracy] ±(0.05% of 10 div + accuracy dependent on the input frequency) [Accuracy dependent on the input frequency] When input frequency is 2 kHz or less: 0.05% of the input frequency + 0.001 Hz Input frequency of 2 kHz to 10 kHz: 0.1% of the input frequency Input frequency of 10 kHz to 20 kHz: 0.3% of the input frequency Input frequency of 20 kHz or higher: 0.5% of the input frequency</li> <li>• <b>When in power supply frequency mode<sup>7</sup></b> When the center frequency is 50/60 Hz: ±0.03 Hz (0.01 Hz resolution) When the center frequency is 400 Hz: ±0.3 Hz (0.01 Hz resolution) (Input set to AC100V or AC200V with sine wave input)</li> <li>• <b>When in period measurement mode<sup>6</sup></b> Measurement accuracy is specified according to the measurement range and input period [Definition of measurement accuracy] ±(0.05% of 10 div + accuracy dependent on the input period) [Accuracy dependent on the input period] Input period of 500 μ s or greater: 0.05% of the input period Input period of 100 μ s to 500 μ s: 0.1% of the input period Input period of 50 μ s to 100 μ s: 0.3% of the input period Input period of 50 μ s or less: 0.5% of the input period + 0.1 μ s</li> <li>• <b>When in duty cycle measurement mode<sup>8</sup></b> Dependent on the input frequency Input frequency of 1 kHz or less: ±0.1% Input frequency of 1 kHz to 10 kHz: ±0.2% Input frequency of 10 kHz to 50 kHz: ±1.0% Input frequency of 50 kHz to 100 kHz: ±2.0% Input frequency of 100 kHz to 200 kHz: ±4.0%</li> <li>• <b>When in pulse width measurement mode<sup>8</sup></b> Measurement accuracy is specified according to the measurement range and input pulse width [Definition of measurement accuracy] ±(0.05% of 10 div + accuracy dependent on the input pulse width) [Accuracy dependent on the input pulse width] Input pulse width of 500 μ s or greater: 0.05% of the input pulse width Input pulse width of 100 μ s to 500 μ s: 0.1% of the input pulse width Input pulse width of 50 μ s to 100 μ s: 0.3% of the input pulse width Input pulse width of 50 μ s or less: 0.5% of the input pulse width + 0.1 μ s</li> </ul>

## 19.12 Module Specifications

Item	Specifications
Input voltage range ( $\pm$ FS)	When using 1:1 probe attenuation: $\pm 1$ V, $\pm 2$ V, $\pm 5$ V, $\pm 10$ V, $\pm 20$ V, $\pm 50$ V ( $\pm$ FS) When using 10:1 probe attenuation: $\pm 10$ V, $\pm 20$ V, $\pm 50$ V, $\pm 100$ V, $\pm 200$ V, $\pm 500$ V ( $\pm$ FS) (combined with the recommended probe 700929)
Input impedance	1 M $\Omega$ $\pm$ 1%, approx. 35 pF Pull-up function: 4.7 k $\Omega$ , approx. 5 V (pull-up can be turned ON only when the input is set to Pull-Up 5V)
Input coupling settings	AC and DC
Probe attenuation setting	10:1 and 1:1
Minimum voltage width for pulse detection	200 mV <sub>P-P</sub>
Bandwidth limit	Select from Full, 100 kHz, 10 kHz, 1 kHz, and 100 Hz Cutoff characteristics: -12 dB/OCT (typical <sup>9</sup> )
Threshold	Set within the FS of the voltage range. Set in units of 1% of the FS.
Hysteresis	Select $\pm$ 1%, $\pm$ 2.5%, or $\pm$ 5% of the FS of the voltage range
Preset function	Logic (5V/3V/12V/24V), electromagnetic pickup, zero crossing, pull-up, AC100V, AC200V, and user-defined
Slope selection	Select rising or falling
Lower -3 dB point when AC coupled	0.5 Hz or less (0.05 Hz or less when using the 700929) (typical <sup>9</sup> )
Chatter elimination function	OFF or 1 to 1000 ms (1 ms resolution) Eliminates the chatter that occurs such when the contact input is turned ON/OFF. Can discard the signal changes over the specified interval.
Input status indication function	Input status indication through the LEDs of each channel When in operation: Illuminates in green when pulse input is detected When overdriven: Illuminates in red when the input voltage exceeds the range
Compatible probes/cables	Connection cable (1:1): Recommended 1 366926 Voltage probe (10:1 safety probe): Recommended 2 700929 (10:1 safety probe) .20 to 45 pF: For measuring 1000 V (DC+ACpeak) or less

1 Value measured under standard operating conditions (section 19.11).

**Combined with the 700929**

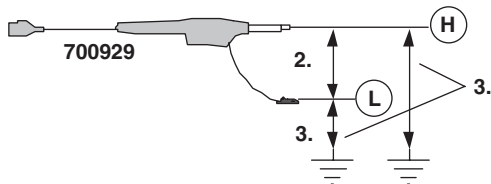

**Direct input (cable not complying with the safety standard)**

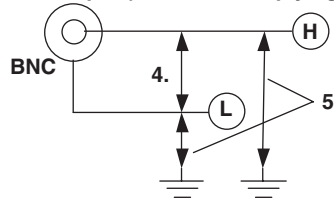

**Withstand voltage: 1500 Vrms for 1 minute**  
**Allowable transient surge voltage (between earth and input):  $\pm$ 2100 Vpeak**

- 6 Input waveform of 1 Vpp, rectangular wave, rise/fall time within 1 ms (input range:  $\pm$ 10 V, bandwidth limit: Full, and hysteresis:  $\pm$ 1%)
- 7 Input waveform of 90 Vrms, sine wave (input range: AC100V, bandwidth limit 100 kHz, and hysteresis:  $\pm$ 1%)
- 8 Input waveform of 1 Vpp, rectangular wave, rise/fall time within 5 ns (input range:  $\pm$ 10 V, bandwidth limit: Full, and hysteresis:  $\pm$ 1%)
- 9 Typical value represents a typical or average value. It is not strictly warranted.



### WARNING

- Do not apply input voltage exceeding the maximum input voltage, withstand voltage, or allowable surge voltage.
- To prevent the possibility of electric shock, be sure to furnish protective earth grounding of the DL750/DL750P.
- To prevent the possibility of electric shock, be sure to fasten the module screws. Otherwise, the electrical and mechanical protection functions will not be activated.
- Avoid continuous connection under an environment in which the allowable surge voltage may occur.

## Specifications by Measurement Modes

Item	Specifications
<b>Frequency</b>	
Measurable frequency range	0.01 Hz to 200 kHz
Selectable vertical axis sensitivity range	0.1 Hz/div to 50 kHz/div (1-2-5 steps)
Minimum resolution	0.00 1Hz
<b>RPMs</b>	
Measurable RPMs range	0.01 rpm to 100000 rpm (where the input frequency is DC to 200 kHz).
Selectable vertical axis sensitivity range	0.1 rpm/div to 10 krpm/div (1-2-5 steps)
Computing method	Computed from the frequency based on the number of pulses per rotation RPMs = Frequency/(pulse/rotate value) × 60
Selectable pulse/rotate range	1 to 99999
<b>RPSs</b>	
Measurable RPSs range	0.001 rps to 2000 rps (where the input frequency is DC to 200 kHz).
Selectable vertical axis sensitivity range	0.01 rps/div to 200 rps/div (1-2-5 steps)
Computing method	Computed from the frequency based on the number of pulses per rotation RPSs = Frequency/(pulse/rotate value)
Selectable pulse/rotate range	1 to 99999
<b>Period</b>	
Measurable period range	5 ms to 50 s (where the minimum pulse width is 2 μ s)
Selectable vertical axis sensitivity range	10 μ s to 500 μ s, 1 ms to 500 ms, 1 to 5 s/div (1-2-5 steps)
Minimum resolution	0.1 μ s
<b>Duty cycle</b>	
Measurable duty cycle range	0 to 100%
Selectable vertical axis sensitivity range	1 to 20% (1-2-5 steps)
Measurable frequency range	0.1 Hz to 200 kHz
Measurement pulse selection	Select positive or negative pulse
Minimum resolution	0.01%
<b>Power supply frequency</b>	
Measurable frequency range	30 Hz to 70 Hz (when the center frequency is 50 Hz), 40 Hz to 80 Hz (when the center frequency is 60 Hz), 380 Hz to 420 Hz (when the center frequency is 400 Hz)
Selectable vertical axis sensitivity range	0.1 Hz/div to 2 Hz/div (0.01 Hz resolution)
Center frequency setting	Select 50 Hz, 60 Hz, or 400 Hz
Minimum resolution	0.01 Hz
<b>Pulse width</b>	
Measurable pulse width	2 μ s to 50 s (where the input frequency is up to 200 kHz)
Selectable vertical axis sensitivity range	10 μ s to 500 μ s, 1 ms to 500 ms, 1 to 5 s/div (1-2-5 steps)
Measurement pulse selection	Select positive or negative pulse
Minimum resolution	0.1 μ s
<b>Pulse integration</b>	
Maximum pulse count	2×10 <sup>9</sup> pulses
Selectable vertical axis sensitivity range	500.0E+18 value/div to 10.00E−21 value/div (1-2-5 range: total of 123 ranges)
Frequency measuring range	0.1 Hz to 200 kHz (where the minimum pulse width is 2 μ s)
Computation function	Set the physical amount per pulse and display by converting the values into physical values such as distance and flow rate.
Selectable Unit/Pulse range	−9.9999E+30 to +9.9999E+30
Counter reset	Manual reset and over-limit reset
<b>Velocity</b>	
Selectable vertical axis sensitivity range	500.0E+18 value/div to 10.00E−21 value/div (1-2-5 range: total of 123 ranges)
Computing method	Set the amount of displacement per pulse and compute the velocity from the frequency Automatic unit time conversion of s, min, and hour.
Selectable Distance/Pulse range	−9.9999E+30 to +9.9999E+30

## 19.12 Module Specifications

---

### Functional Specifications

Item	Specifications
Deceleration prediction	Computes the deceleration condition in realtime when the pulse input is cut off. Can be specified when measuring the frequency, RPMs, RPSs, period, and velocity
Stop prediction	Sets the frequency to 0 after a certain time elapses after the pulse input is cut off. Stop interval setting: Set in the range of 1.5 to 10 times (10 settings) the period of the pulse measured last Can be specified when measuring the frequency, RPMs, RPSs, period, and velocity
Smoothing	Computes the moving average of the measured data using the specified time Specified time: 0.1 to 1000 ms (0.1 ms resolution) Can be specified on all measurement parameters
Pulse average	Performs frequency measurement per specified number of pulses. When fluctuation exists periodically in the pulse interval, the fluctuation can be eliminated. Specified number of pulses: 1 to 4096 Can be specified when measuring the frequency, RPMs, RPSs, power supply frequency, period, pulse integration, and velocity
Offset function	Observe fluctuation with respect to the offset frequency Offset range: Can be set up to 1000 times the maximum value/div value • Frequency: 0 Hz to 200 kHz • RPMs: 0 rpm to 50 krpm • RPSs: 0 rps to 1000 rps • Period: 0 s to 50 s • Duty cycle: 0% to 100% • Pulse width: 0 s to 50 s • Pulse integration: $-1.0000 \times 10^{22}$ to $1.0000 \times 10^{22}$ • Velocity: $-1.0000 \times 10^{22}$ to $1.0000 \times 10^{22}$

---

## 19.13 Logic Probe Specifications

### High-Speed Logic Probe (700986) Specifications

Item	Specifications
Number of input points	8
Input format	Non-isolated (the earth of each bit are common, the earth of the DL750/DL750P and the earth of each bit are common)
Maximum input voltage	42 V (DC+ACpeak)(CAT I and CAT II, 30 Vrms), across probe tip and earth (at a frequency of 1 kHz or less)
Response time	1 $\mu$ s or less
Input impedance	100 k $\Omega$ or more
Threshold level	approx. 1.4 V

### Isolation Logic Probe (700987) Specifications

Item	Specifications										
Number of input points	8										
Input format	Isolated (all bits are isolated)										
Input connector	Safety terminal type (for banana plug) $\times$ 8										
Input switching	Can switch between AC/DC input for each bit										
Input signal display	Can confirm H/L with the LED for each bit (lights when H)										
Applicable input range	During DC input: H/L detection of 10 VDC to 250 VDC During AC input: H/L detection of AC type of 80 VAC to 250 VAC 50/60 Hz										
Threshold level	During DC input: 6 V $\pm$ 50% (Hi level: 10 to 250 VDC, Lo level: 0 to 3 VDC) During AC input: 50 VAC $\pm$ 50% (Hi level: 80 to 250 VDC, Lo level: 0 to 20 VAC)										
Response time	During DC input: within 1 ms During AC input: within 20 ms										
Input impedance	approx. 100 k $\Omega$										
Maximum input voltage (across H and L of each bit)	250 Vrms <sup>1</sup> (CAT I and II)										
Maximum allowable common mode voltage (across input terminal H or L and earth)	250 Vrms <sup>1</sup> (CAT I and II)										
Maximum allowable voltage between bits	250 Vrms <sup>1</sup> (CAT I and II)										
Withstand voltage (across input terminal and earth)	2000 VAC for 1 minute										
Isolation resistance (across input terminal and earth)	500 VDC, 10 M $\Omega$ or more										
Fuse <sup>2</sup>	<table border="1"> <thead> <tr> <th>location</th> <th>max. rated voltage</th> <th>max. rated current</th> <th>type</th> <th>standard</th> </tr> </thead> <tbody> <tr> <td>H side of input terminal</td> <td>250 V</td> <td>50 mA</td> <td>time lag</td> <td>VDE/SEMKO</td> </tr> </tbody> </table>	location	max. rated voltage	max. rated current	type	standard	H side of input terminal	250 V	50 mA	time lag	VDE/SEMKO
location	max. rated voltage	max. rated current	type	standard							
H side of input terminal	250 V	50 mA	time lag	VDE/SEMKO							

1. Make sure the ACpeak voltage does not exceed 350 V and the DC voltage does not exceed 250 V when the frequency is 1 kHz or less.
2. Because the fuses used by this instrument are all inside the case, they cannot be exchanged by the user. If you believe the fuse inside the case is blown, please contact your nearest YOKOGAWA dealer.

# 19.14 External Dimensions

DL750

Unit: mm

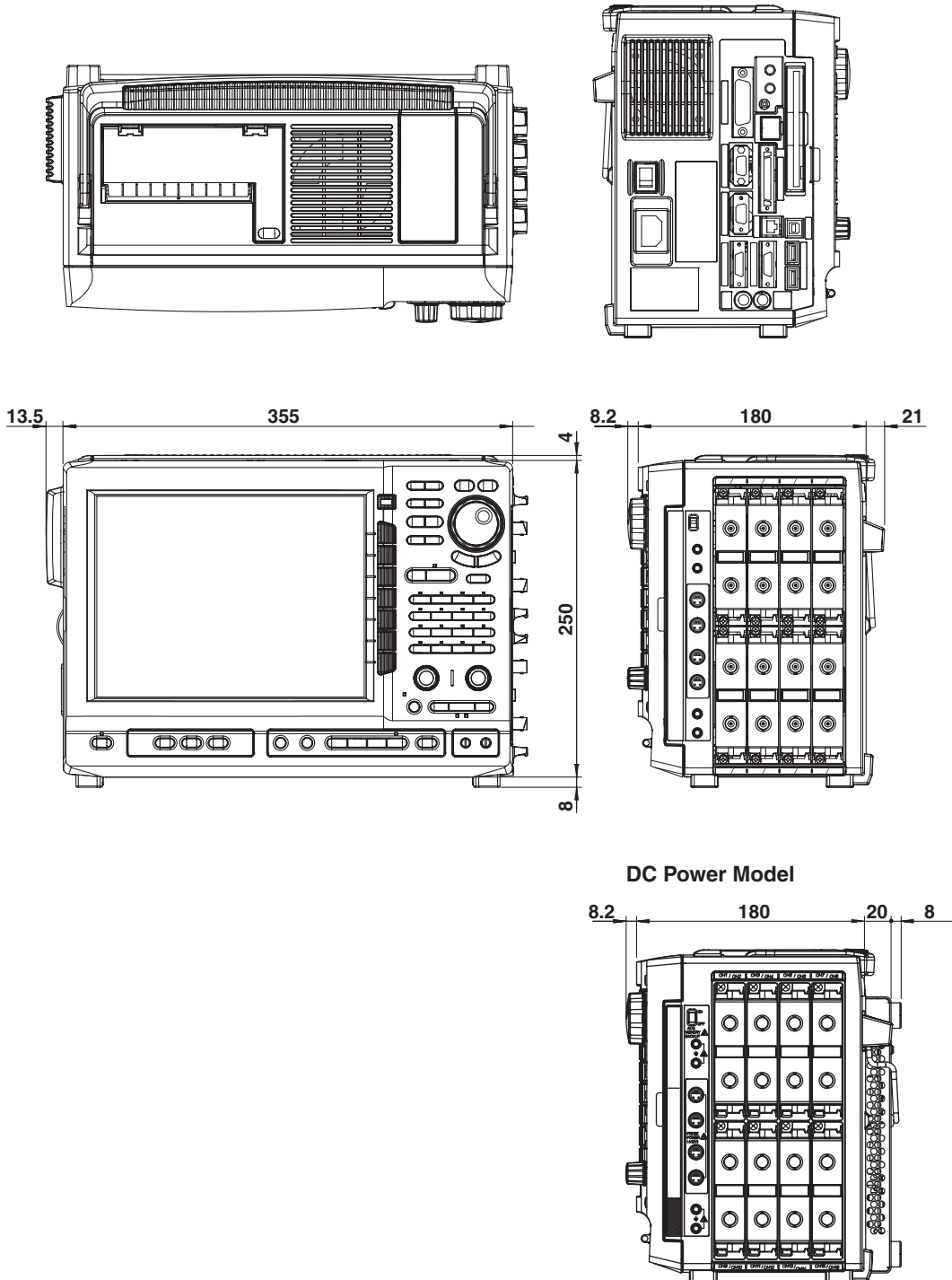

If not specified, the tolerance is  $\pm 3\%$ . However, in cases of less than 10 mm, the tolerance is  $\pm 0.3$  mm.

DL750P

Unit: mm

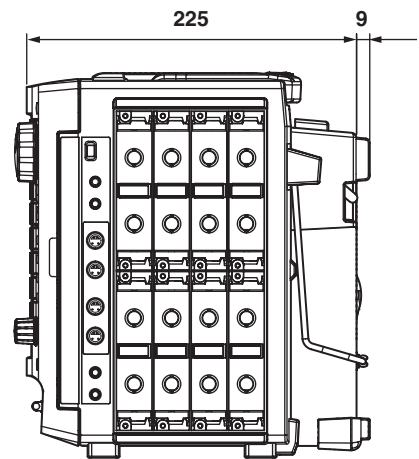
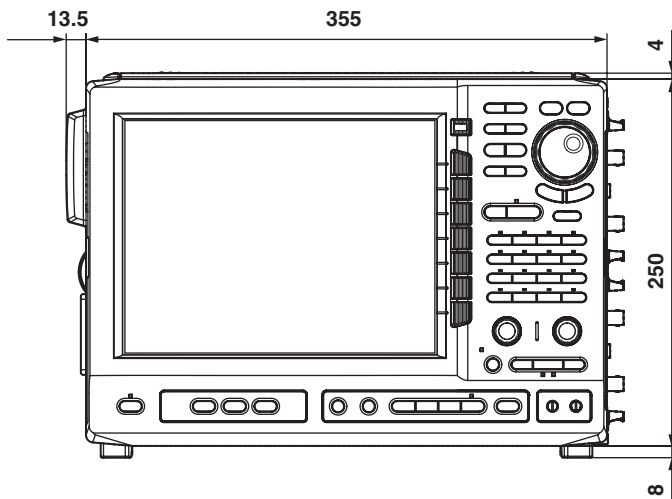
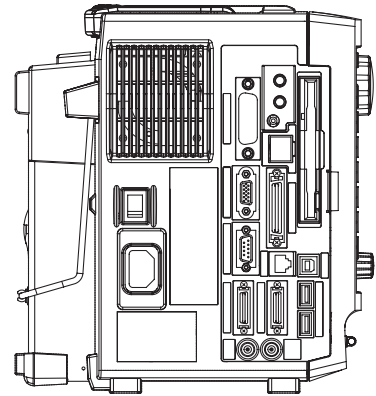
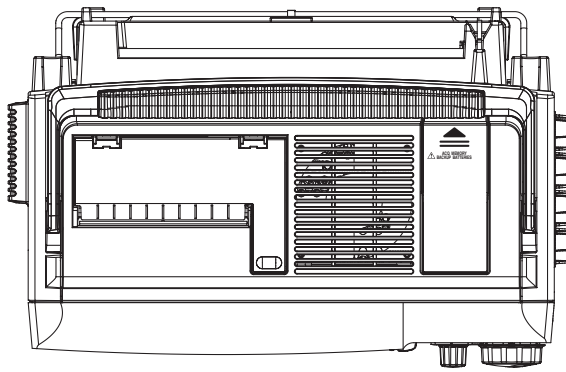

Rear View

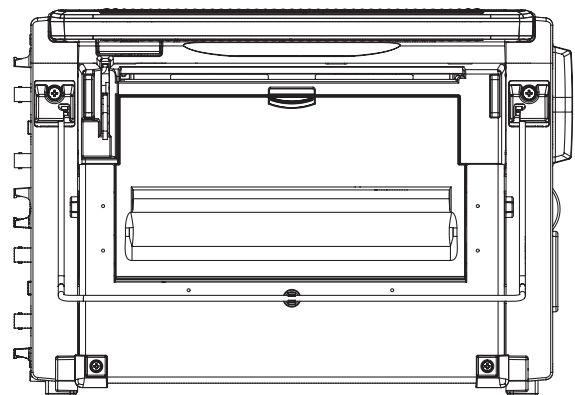

If not specified, the tolerance is  $\pm 3\%$ . However, in cases of less than 10 mm, the tolerance is  $\pm 0.3$  mm.



Modules

- High-Speed 10 MS/s, 12-Bit Isolation Module (701250)
- High-Speed High-Resolution 1 MS/s, 16-Bit Isolation Module (701251)
- High-Speed 10 MS/s, 12-Bit Non-Isolation Module (701255)
- High-Voltage 100 kS/s, 16-Bit Isolation Module (with RMS) (701260)

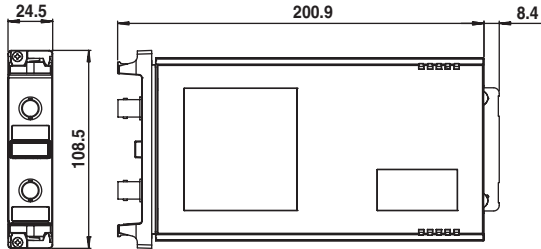

- Universal (Voltage/Temp.) Module (701261)
- Universal (Voltage/Temp.) Module (with AAF) (701262)
- Temperature, High Precision Voltage Isolation Module (701265)

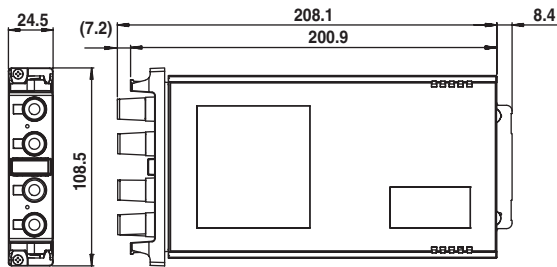

Strain Module (NDIS) (701270)

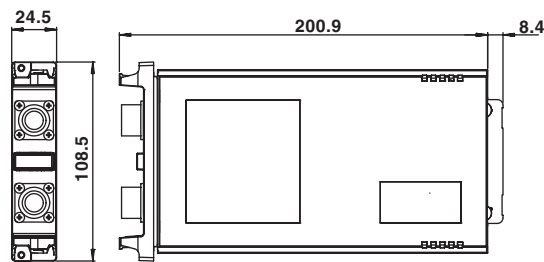

Strain Module (DSUB, Shunt-Cal) (701271)

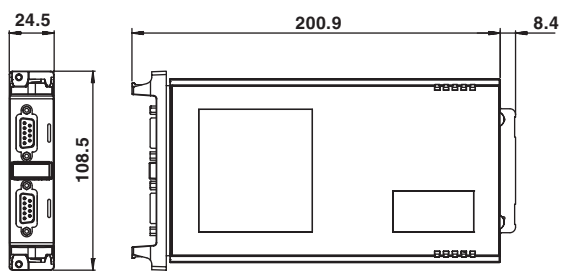

Acceleration/Voltage Module (with AAF) (701275)

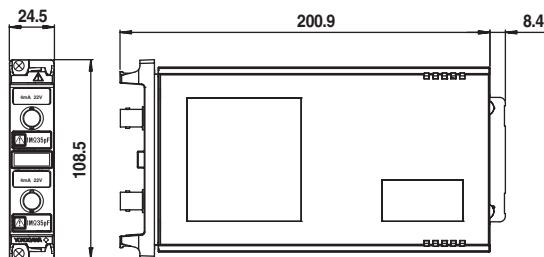

Frequency Module (701280)

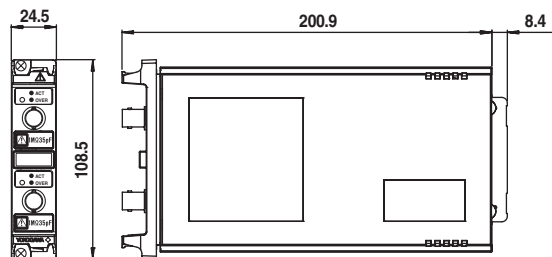

# Appendix 1 Relationship between the Time Axis Setting, Sample Rate and Record Length

T/div	Record Length									
	1 kW		2.5 kW		5 kW		10 kW		25 kW	
	Sample Rate (S/s)	Display Record Length (Word)	Sample Rate (S/s)	Display Record Length (Word)	Sample Rate (S/s)	Display Record Length (Word)	Sample Rate (S/s)	Display Record Length (Word)	Sample Rate (S/s)	Display Record Length (Word)
500ns	10 M	50	10 M	50	10 M	50	10 M	50	10 M	50
1 μs	10 M	100	10 M	100	10 M	100	10 M	100	10 M	100
2 μs	10 M	200	10 M	200	10 M	200	10 M	200	10 M	200
5 μs	10 M	500	10 M	500	10 M	500	10 M	500	10 M	500
10 μs	10 M	1 k	10 M	1 k	10 M	1 k	10 M	1 k	10 M	1 k
20 μs	5 M	1 k	10 M	2 k	10 M	2 k	10 M	2 k	10 M	2 k
50 μs	2 M	1 k	5 M	2.5 k	10 M	5 k	10 M	5 k	10 M	5 k
100 μs	1 M	1 k	2 M	2 k	5 M	5 k	10 M	10 k	10 M	10 k
200 μs	500 k	1 k	1 M	2 k	2 M	4 k	5 M	10 k	10 M	20 k
500 μs	200 k	1 k	500 k	2.5 k	1 M	5 k	2 M	10 k	5 M	25 k
1 ms	100 k	1 k	200 k	2 k	500 k	5 k	1 M	10 k	2 M	20 k
2 ms	50 k	1 k	100 k	2 k	200 k	4 k	500 k	10 k	1 M	20 k
5 ms	20 k	1 k	50 k	2.5 k	100 k	5 k	200 k	10 k	500 k	25 k
10 ms	10 k	1 k	20 k	2 k	50 k	5 k	100 k	10 k	200 k	20 k
20 ms	5 k	1 k	10 k	2 k	20 k	4 k	50 k	10 k	100 k	20 k
50 ms	2 k	1 k	5 k	2.5 k	10 k	5 k	20 k	10 k	50 k	25 k
100 ms	1 k	1 k	2 k	2 k	5 k	5 k	10 k	10 k	20 k	20 k
200 ms	500	1 k	1 k	2 k	2 k	4 k	5 k	10 k	10 k	20 k
500 ms	200	1 k	500	2.5 k	1 k	5 k	2 k	10 k	5 k	25 k
1 s	100	1 k	200	2 k	500	5 k	1 k	10 k	2 k	20 k
2 s	50	1 k	100	2 k	200	4 k	500	10 k	1 k	20 k
3 s	20	600	50	1.5 k	100	3 k	200	6 k	500	15 k
4 s	20	800	50	2 k	100	4 k	200	8 k	500	20 k
5 s	20	1 k	50	2.5 k	100	5 k	200	10 k	500	25 k
6 s	10	600	20	1.2 k	50	3 k	100	6 k	200	12 k
8 s	10	800	20	1.6 k	50	4 k	100	8 k	200	16 k
10 s	10	1 k	20	2 k	50	5 k	100	10 k	200	20 k
20 s	5	1 k	10	2 k	20	4 k	50	10 k	100	20 k
30 s			5	1.5 k	10	3 k	20	6 k	50	15 k
1 min					5	3 k	10	6 k	20	12 k
2 min							5	6 k	20	24 k
3 min							5	9 k	10	18 k
4 min									10	24 k
5 min									5	15 k
6 min									5	18 k
7 min									5	21 k
8 min										
9 min										
10 min										
12 min										
15 min										
30 min										
1 h										
2 h										
3 h										
4 h										
5 h										
6 h										
7 h										
8 h										
9 h										
10 h										
12 h										
1 day										
2 day										
3 day										

For the settings inside the thick frame, the waveform is displayed in roll mode when the trigger mode is set to auto or auto-level.

**Appendix 1 Relationship between the Time Axis Setting, Sample Rate and Record Length**

T/div	Record Length									
	50 kW		100 kW		250 kW		500 kW		1 MW	
	Sample Rate (S/s)	Display Record Length (Word)	Sample Rate (S/s)	Display Record Length (Word)	Sample Rate (S/s)	Display Record Length (Word)	Sample Rate (S/s)	Display Record Length (Word)	Sample Rate (S/s)	Display Record Length (Word)
500ns	10 M	50	10 M	50	10 M	50	10 M	50	10 M	50
1 μs	10 M	100	10 M	100	10 M	100	10 M	100	10 M	100
2 μs	10 M	200	10 M	200	10 M	200	10 M	200	10 M	200
5 μs	10 M	500	10 M	500	10 M	500	10 M	500	10 M	500
10 μs	10 M	1 k	10 M	1 k	10 M	1 k	10 M	1 k	10 M	1 k
20 μs	10 M	2 k	10 M	2 k	10 M	2 k	10 M	2 k	10 M	2 k
50 μs	10 M	5 k	10 M	5 k	10 M	5 k	10 M	5 k	10 M	5 k
100 μs	10 M	10 k	10 M	10 k	10 M	10 k	10 M	10 k	10 M	10 k
200 μs	10 M	20 k	10 M	20 k	10 M	20 k	10 M	20 k	10 M	20 k
500 μs	10 M	50 k	10 M	50 k	10 M	50 k	10 M	50 k	10 M	50 k
1 ms	5 M	50 k	10 M	100 k	10 M	100 k	10 M	100 k	10 M	100 k
2 ms	2 M	40 k	5 M	100 k	10 M	200 k	10 M	200 k	10 M	200 k
5 ms	1 M	50 k	2 M	100 k	5 M	250 k	10 M	500 k	10 M	500 k
10 ms	500 k	50 k	1 M	100 k	2 M	200 k	5 M	500 k	10 M	1 M
20 ms	200 k	40 k	500 k	100 k	1 M	200 k	2 M	400 k	5 M	1 M
50 ms	100 k	50 k	200 k	100 k	500 k	250 k	1 M	500 k	2 M	1 M
100 ms	50 k	50 k	100 k	100 k	200 k	200 k	500 k	500 k	1 M	1 M
200 ms	20 k	40 k	50 k	100 k	100 k	200 k	200 k	400 k	500 k	1 M
500 ms	10 k	50 k	20 k	100 k	50 k	250 k	100 k	500 k	200 k	1 M
1 s	5 k	50 k	10 k	100 k	20 k	200 k	50 k	500 k	100 k	1 M
2 s	2 k	40 k	5 k	100 k	10 k	200 k	20 k	400 k	50 k	1 M
3 s	1 k	30 k	2 k	60 k	5 k	150 k	10 k	300 k	20 k	600 k
4 s	1 k	40 k	2 k	80 k	5 k	200 k	10 k	400 k	20 k	800 k
5 s	1 k	50 k	2 k	100 k	5 k	250 k	10 k	500 k	20 k	1 M
6 s	500	30 k	1 k	60 k	2 k	120 k	5 k	300 k	10 k	600 k
8 s	500	40 k	1 k	80 k	2 k	160 k	5 k	400 k	10 k	800 k
10 s	500	50 k	1 k	100 k	2 k	200 k	5 k	500 k	10 k	1 M
20 s	200	40 k	500	100 k	1 k	200 k	2 k	400 k	5 k	1 M
30 s	100	30 k	200	60 k	500	150 k	1 k	300 k	2 k	600 k
1 min	50	30 k	100	60 k	200	120 k	500	300 k	1 k	600 k
2 min	20	24 k	50	60 k	200	240 k	200	240 k	500	600 k
3 min	20	36 k	50	90 k	100	180 k	200	360 k	500	900 k
4 min	20	48 k	20	48 k	100	240 k	200	480 k	200	480 k
5 min	10	30 k	20	60 k	50	150 k	100	300 k	200	600 k
6 min	10	36 k	20	72 k	50	180 k	100	360 k	200	720 k
7 min	10	42 k	20	84 k	50	210 k	100	420 k	200	840 k
8 min	10	48 k	20	96 k	50	240 k	100	480 k	200	960 k
9 min	5	27 k	10	54 k	20	108 k	50	270 k	100	540 k
10 min	5	30 k	10	60 k	20	120 k	50	300 k	100	600 k
12 min	5	36 k	10	72 k	20	144 k	50	360 k	100	720 k
15 min	5	45 k	10	90 k	20	180 k	50	450 k	100	900 k
30 min			5	90 k	10	180 k	20	360 k	50	900 k
1 h					5	180 k	10	360 k	20	720 k
2 h							5	360 k	10	720 k
3 h									5	540 k
4 h									5	720 k
5 h									5	900 k
6 h										
7 h										
8 h										
9 h										
10 h										
12 h										
1 day										
2 day										
3 day										

For the settings inside the thick frame, the waveform is displayed in roll mode when the trigger mode is set to auto or auto-level.

**Appendix 1 Relationship between the Time Axis Setting, Sample Rate and Record Length**

T/div	Record Length									
	2.5 MW		5 MW		10 MW		25 MW		50 MW	
	Sample Rate (S/s)	Display Record Length (Word)	Sample Rate (S/s)	Display Record Length (Word)	Sample Rate (S/s)	Display Record Length (Word)	Sample Rate (S/s)	Display Record Length (Word)	Sample Rate (S/s)	Display Record Length (Word)
500ns	10 M	50	10 M	50	10 M	50	10 M	50	10 M	50
1 μs	10 M	100	10 M	100	10 M	100	10 M	100	10 M	100
2 μs	10 M	200	10 M	200	10 M	200	10 M	200	10 M	200
5 μs	10 M	500	10 M	500	10 M	500	10 M	500	10 M	500
10 μs	10 M	1 k	10 M	1 k	10 M	1 k	10 M	1 k	10 M	1 k
20 μs	10 M	2 k	10 M	2 k	10 M	2 k	10 M	2 k	10 M	2 k
50 μs	10 M	5 k	10 M	5 k	10 M	5 k	10 M	5 k	10 M	5 k
100 μs	10 M	10 k	10 M	10 k	10 M	10 k	10 M	10 k	10 M	10 k
200 μs	10 M	20 k	10 M	20 k	10 M	20 k	10 M	20 k	10 M	20 k
500 μs	10 M	50 k	10 M	50 k	10 M	50 k	10 M	50 k	10 M	50 k
1 ms	10 M	100 k	10 M	100 k	10 M	100 k	10 M	100 k	10 M	100 k
2 ms	10 M	200 k	10 M	200 k	10 M	200 k	10 M	200 k	10 M	200 k
5 ms	10 M	500 k	10 M	500 k	10 M	500 k	10 M	500 k	10 M	500 k
10 ms	10 M	1 M	10 M	1 M	10 M	1 M	10 M	1 M	10 M	1 M
20 ms	10 M	2 M	10 M	2 M	10 M	2 M	10 M	2 M	10 M	2 M
50 ms	5 M	2.5 M	10 M	5 M	10 M	5 M	10 M	5 M	10 M	5 M
100 ms	2 M	2 M	5 M	5 M	10 M	10 M	10 M	10 M	10 M	10 M
200 ms	1 M	2 M	2 M	4 M	5 M	10 M	10 M	20 M	10 M	20 M
500 ms	500 k	2.5 M	1 M	5 M	2 M	10 M	5 M	25 M	10 M	50 M
1 s	200 k	2 M	500 k	5 M	1 M	10 M	2 M	20 M	5 M	50 M
2 s	100 k	2 M	200 k	4 M	500 k	10 M	1 M	20 M	2 M	40 M
3 s	50 k	1.5 M	100 k	3 M	200 k	6 M	500 k	15 M	1 M	30 M
4 s	50 k	2 M	100 k	4 M	200 k	8 M	500 k	20 M	1 M	40 M
5 s	50 k	2.5 M	100 k	5 M	200 k	10 M	500 k	25 M	1 M	50 M
6 s	20 k	1.2 M	50 k	3 M	100 k	6 M	200 k	12 M	200 k	30 M
8 s	20 k	1.6 M	50 k	4 M	100 k	8 M	200 k	16 M	500 k	40 M
10 s	20 k	2 M	50 k	5 M	100 k	10 M	200 k	20 M	500 k	50 M
20 s	10 k	2 M	20 k	4 M	50 k	10 M	100 k	20 M	200 k	40 M
30 s	5 k	1.5 M	10 k	3 M	20 k	6 M	50 k	15 M	100 k	30 M
1 min	2 k	1.2 M	5 k	3 M	10 k	6 M	20 k	12 M	50 k	30 M
2 min	2 k	2.4 M	2 k	2.4 M	5 k	6 M	20 k	24 M	20 k	24 M
3 min	1 k	1.8 M	2 k	3.6 M	5 k	9 M	10 k	18 M	20 k	36 M
4 min	1 k	2.4 M	2 k	4.8 M	2 k	4.8 M	10 k	24 M	20 k	48 M
5 min	500	1.5 M	1 k	3 M	2 k	6 M	5 k	15 M	10 k	30 M
6 min	500	1.8 M	1 k	3.6 M	2 k	7.2 M	5 k	18 M	10 k	36 M
7 min	500	2.1 M	1 k	4.2 M	2 k	8.4 M	5 k	21 M	10 k	42 M
8 min	500	2.4 M	1 k	4.8 M	2 k	9.6 M	5 k	24 M	10 k	48 M
9 min	200	1.08 M	500	2.7 M	1 k	5.4 M	2 k	10.8 M	5 k	27 M
10 min	200	1.2 M	500	3 M	1 k	6 M	2 k	12 M	5 k	30 M
12 min	200	1.44 M	500	3.6 M	1 k	7.2 M	2 k	14.4 M	5 k	36 M
15 min	200	1.8 M	500	4.5 M	1 k	9 M	2 k	18 M	5 k	45 M
30 min	100	1.8 M	200	3.6 M	500	9 M	1 k	18 M	2 k	36 M
1 h	50	1.8 M	100	3.6 M	200	7.2 M	500	18 M	1 k	36 M
2 h	20	1.44 M	50	3.6 M	100	7.2 M	200	14.4 M	500	36 M
3 h	20	2.16 M	20	2.16 M	50	5.4 M	200	21.6 M	200	21.6 M
4 h	10	1.44 M	20	2.88 M	50	7.2 M	100	14.4 M	200	28.8 M
5 h	10	1.8 M	20	3.6 M	50	9 M	100	18 M	200	36 M
6 h	10	2.16 M	20	4.32 M	20	4.32 M	100	21.6 M	200	43.2 M
7 h	5	1.26 M	10	2.52 M	20	5.04 M	50	12.6 M	100	25.2 M
8 h	5	1.44 M	10	2.88 M	20	5.76 M	50	14.4 M	100	28.8 M
9 h	5	1.62 M	10	3.24 M	20	6.48 M	50	16.2 M	100	32.4 M
10 h	5	1.8 M	10	3.6 M	20	7.2 M	50	18 M	100	36 M
12 h	5	2.16 M	10	4.32 M	20	8.64 M	50	21.6 M	100	43.2 M
1 day			5	4.32 M	10	8.64 M	20	17.28 M	50	43.2 M
2 day					5	8.64 M	10	17.28 M	20	34.56 M
3 day							5	12.96 M	10	25.92 M

For the settings inside the thick frame, the waveform is displayed in roll mode when the trigger mode is set to auto or auto-level.

**Appendix 1 Relationship between the Time Axis Setting, Sample Rate and Record Length**

	Record Length							
	100 MW		250 MW		500 MW		1 GW	
T/div	Sample Rate (S/s)	Display Record Length (Word)	Sample Rate (S/s)	Display Record Length (Word)	Sample Rate (S/s)	Display Record Length (Word)	Sample Rate (S/s)	Display Record Length (Word)
500ns	10 M	50	10 M	50	10 M	50	10 M	50
1 μs	10 M	100	10 M	100	10 M	100	10 M	100
2 μs	10 M	200	10M	200	10 M	200	10 M	200
5 μs	10 M	500	10 M	500	10 M	500	10 M	500
10 μs	10 M	1 k	10 M	1 k	10 M	1 k	10 M	1 k
20 μs	10 M	2 k	10 M	2 k	10 M	2 k	10 M	2 k
50 μs	10 M	5 k	10 M	5 k	10 M	5 k	10 M	5 k
100 μs	10 M	10 k	10 M	10 k	10 M	10 k	10 M	10 k
200 μs	10 M	20 k	10 M	20 k	10 M	20 k	10 M	20 k
500 μs	10 M	50 k	10 M	50 k	10 M	50 k	10 M	50 k
1 ms	10 M	100 k	10 M	100 k	10 M	100 k	10 M	100 k
2 ms	10 M	200 k	10 M	200 k	10 M	200 k	10 M	200 k
5 ms	10 M	500 k	10 M	500 k	10 M	500 k	10 M	500 k
10 ms	10 M	1 M	10 M	1 M	10 M	1 M	10 M	1 M
20 ms	10 M	2 M	10 M	2 M	10 M	2 M	10 M	2 M
50 ms	10 M	5 M	10 M	5 M	10 M	5 M	10 M	5 M
100 ms	10 M	10 M	10 M	10 M	10 M	10 M	10 M	10 M
200 ms	10 M	20 M	10 M	20 M	10 M	20 M	10 M	20 M
500 ms	10 M	50 M	10 M	50 M	10 M	50 M	10 M	50 M
1 s	10 M	100 M	10 M	100 M	10 M	100 M	10 M	100 M
2 s	5 M	100 M	10 M	200 M	10 M	200 M	10 M	200 M
3 s	2 M	60 M	5 M	150 M	10 M	300 M	10 M	300 M
4 s	2 M	80 M	5 M	200 M	10 M	400 M	10 M	400 M
5 s	2 M	100 M	5 M	250 M	10 M	500 M	10 M	500 M
6 s	1 M	60 M	2 M	120 M	5 M	300 M	10 M	600 M
8 s	1 M	80 M	2 M	160 M	5 M	400 M	10 M	800 M
10 s	1 M	100 M	2 M	200 M	5 M	500 M	10 M	1000 M
20 s	500 k	100 M	1 M	200 M	2 M	400 M	5 M	1000 M
30 s	200 k	60 M	500 k	150 M	1 M	300 M	2 M	600 M
1 min	100 k	60 M	200 k	120 M	500 k	300 M	1 M	600 M
2 min	50 k	60 M	200 k	240 M	200 k	240 M	500 k	600 M
3 min	50 k	90 M	100 k	180 M	200 k	360 M	500 k	900 M
4 min	20 k	48 M	100 k	240 M	200 k	480 M	200 k	480 M
5 min	20 k	60 M	50 k	150 M	100 k	300 M	200 k	600 M
6 min	20 k	72 M	50 k	180 M	100 k	360 M	200k	720 M
7 min	20 k	84 M	50 k	210 M	100 k	420 M	200 k	840 M
8 min	20 k	96 M	50 k	240 M	100 k	480 M	200 k	960 M
9 min	10 k	54 M	20 k	108 M	50 k	270 M	100 k	540 M
10 min	10 k	60 M	20 k	120 M	50 k	300 M	100 k	600 M
12 min	10 k	72 M	20 k	144 M	50 k	360 M	100 k	720 M
15 min	10 k	90 M	20 k	180 M	50 k	450 M	100 k	900 M
30 min	5 k	90 M	10 k	180 M	20 k	360 M	50 k	900 M
1 h	2 k	72 M	5 k	180 M	10 k	360 M	20 k	720 M
2 h	1 k	72 M	2 k	144 M	5 k	360 M	10 k	720 M
3 h	500	54 M	2 k	216 M	2 k	216 M	5 k	540 M
4 h	500	72 M	1 k	144 M	2 k	288 M	5 k	720 M
5 h	500	90 M	1 k	180 M	2 k	360 M	5 k	900 M
6 h	200	43.2 M	1 k	216 M	2 k	432 M	2 k	432 M
7 h	200	50.4 M	500	126 M	1 k	252 M	2 k	504 M
8 h	200	57.6 M	500	144 M	1 k	288 M	2 k	576 M
9 h	200	64.8 M	500	162 M	1 k	324 M	2 k	648 M
10 h	200	72 M	500	180 M	1 k	360 M	2 k	720 M
12 h	200	86.4 M	500	216 M	1 k	432 M	2 k	864 M
1 day	100	86.4 M	200	172.8 M	500	432 M	1 k	864 M
2 day	50	86.4 M	100	172.8 M	200	345.6 M	500	864 M
3 day	20	51.84 M	50	129.6 M	100	259.2 M	200	518.4 M

For the settings inside the thick frame, the waveform is displayed in roll mode when the trigger mode is set to auto or auto-level.

## Appendix 2 Relationship between the Record Length and Acquisition Mode

### Selectable Maximum Record Length

#### When the Acquisition Mode Is Set to a Mode Other Than Average

The maximum record length for each model varies depending on the number of display channels as follows:

Model \ Number of Displayed Channels	Standard	/M1 (10 M)	/M2 (25 M)	/M3 (50 M)
12 channels or more	2.5 M	10 M	25 M	50 M
10 to 11 channels	5 M	10 M	50 M	50 M
6 to 9 channels	5 M	10 M	50 M	100 M
4 to 5 channels	10 M	25 M	100 M	100 M
3 channels	25 M	50 M	100 M	250 M
2 channels	25 M	100 M	250 M	500 M
1 channel	50 M	250 M	500 M	1 G

Record length unit: Word

#### When the Acquisition Mode Is Set to Average

Model \ Number of Displayed Channels	Standard	/M1 (10 M)	/M2 (25 M)	/M3 (50 M)
1 to 22 channels	1 M	2.5 M	5 M	10 M

Record length unit: Word

### Maximum Number of Acquisitions of History Memory

The maximum number of acquisitions per model is as follows:

Model \ Record Length	Standard	/M1 (10 M)	/M2 (25 M)	/M3 (50 M)
1 k	2000	2000	2000	2000
2.5 k	483	1454	2000	2000
5 k	324	976	2000	2000
10 k	241	728	1581	2000
25 k	121	369	803	1608
50 k	60	185	403	809
100 k	29	92	202	406
250 k	11	38	85	172
500 k	4	18	41	85
1 M	3	8	19	41
2.5 M	1	2	6	15
5 M	1	2	2	6
10 M	1	1	2	2
25 M	1	1	1	2
50 M	1	1	1	1
100 M	–	1	1	1
250 M	–	1	1	1
500 M	–	–	1	1
1 G	–	–	–	1

Record length unit: Word

**Possible Time Axis Range, Maximum Record Length, and Maximum Sample Rate for Realtime Recording**

Varies depending on the number of channels that are to be realtime recorded as follows:

<b>Channels Used</b>	<b>Time Axis Range</b>	<b>Maximum Record Length</b>	<b>Maximum Sample Rate</b>
18CH or more	20 s/div to 3 day/div	25 MW	5 kS/s
12 to 17CH	20 s/div to 3 day/div	50 MW	5 kS/s
6 to 11CH	10 s/div to 3 day/div	50 MW	10 kS/s
4 to 5CH	6 s/div to 3 day/div	100 MW	20 kS/s
3CH	3 s/div to 3 day/div	250 MW	50 kS/s
2CH	1 s/div to 3 day/div	500 MW	100 kS/s
1CH	1 s/div to 3 day/div	1 GW	100 kS/s

# Appendix 3 How to Calculate the Area of a Waveform

## Integ1TY

Total Area for Positive Side Only:  $S_1+S_2$

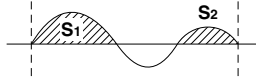

## Integ2TY

Total Area for both Positive and Negative Sides:  $S_1+S_3-S_2$

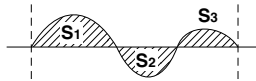

## Integ1XY

(1) Multiple Loops

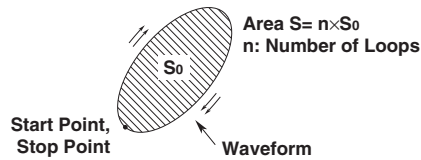

(2) Non-Closed Curve

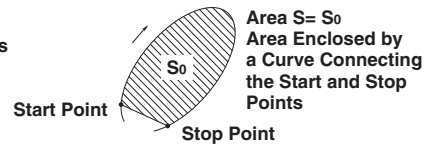

(3) Loop Tracing a Figure-Eight

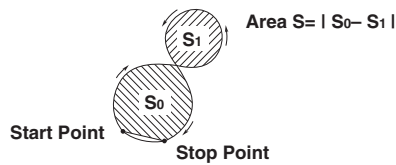

(4) Spiral Loop

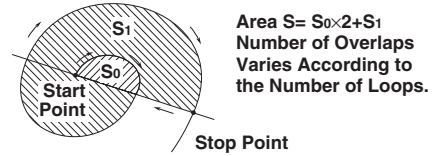



**Appendix 3 How to Calculate the Area of a Waveform**

**Integ2XY**

(1) When Only One Y Data Corresponds to X Data

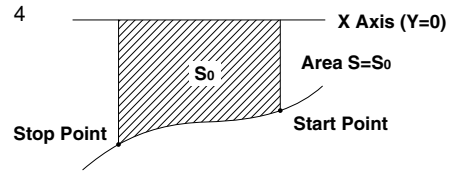
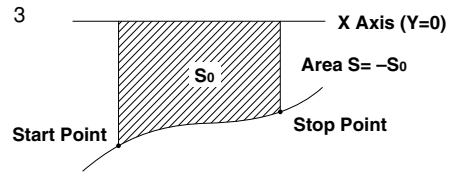
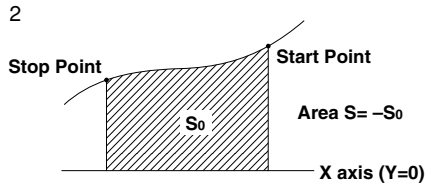
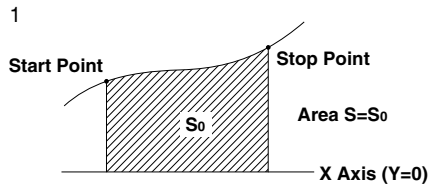

(2) When the Waveform Extends into the Negative Side

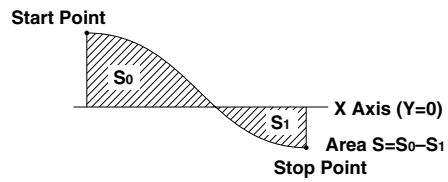

(2) When Two or more Y Data Correspond to X Data

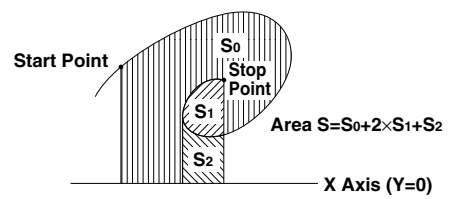
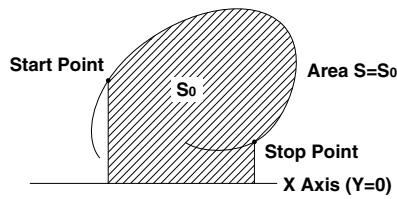

## Appendix 4 ASCII Header File Format

//YOKOGAWA ASCII

FILE FORMAT

\$PublicInfo

FormatVersion 1.11  
 Model DL750  
 Endian Big  
 DataFormat Trace  
 GroupNumber 4  
 TraceTotalNumber 13  
 DataOffset 111548

\$Group1

TraceNumber	4			
BlockNumber	1			
TraceName	CH1	CH2	CH3	CH4
BlockSize	10010	10010	10010	10010
VResolution	4.1666667E-04	2.0833333E-02	2.0833333E-02	2.0833333E-02
VOffset	1.0000000E+00	0.0000000E+00	0.0000000E+00	0.0000000E+00
VDataType	IS2	IS2	IS2	IS2
VUnit	?	V	V	V
VPlusOverData	?	?	?	?
VMinusOverData	?	?	?	?
VIllegalData	-32768	-32768	-32768	-32768
VMaxData	32767	32767	32767	32767
VMinData	-32767	-32767	-32767	-32767
HResolution	2.0000000E-04	2.0000000E-04	2.0000000E-04	2.0000000E-04
HOffset	-2.0018000E+00	-2.0018000E+00	-2.0018000E+00	2.0018000E+00
HUnit	s	s	s	s
Date	2004/1/15	2004/1/15	2004/1/15	2004/1/15
Time	14:25:38.54	14:25:38.54	14:25:38.54	14:25:38.54

\$Group2

TraceNumber	4			
BlockNumber	1			
TraceName	CH5	CH6	CH7	CH8
BlockSize	10010	10010	10010	10010
VResolution	2.0833333E-03	2.0833333E-03	2.0833333E-03	2.0833333E-03
VOffset	0.0000000E+00	0.0000000E+00	0.0000000E+00	0.0000000E+00
VDataType	IS2	IS2	IS2	IS2
VUnit	V	V	V	V
VPlusOverData	?	?	?	?
VMinusOverData	?	?	?	?
VIllegalData	-32768	-32768	-32768	-32768
VMaxData	32767	32767	32767	32767
VMinData	-32767	-32767	-32767	-32767
HResolution	2.0000000E-04	2.0000000E-04	2.0000000E-04	2.0000000E-04

## Appendix 4 ASCII Header File Format

---

HOffset	-2.0018000E+00	-2.0018000E+00	-2.0018000E+00	2.0018000E+00
HUnit	s	s	s	s
Date	2004/1/15	2004/1/15	2004/1/15	2004/1/15
Time	14:25:38.54	14:25:38.54	14:25:38.54	14:25:38.54

### \$Group3

TraceNumber	4			
BlockNumber	1			
TraceName	CH15	CH16	Math1	Math2
BlockSize	10010	10010	10010	10010
VResolution	4.1666667E-01	4.1666667E-01	2.0833333E-04	2.0833332E-05
VOffset	0.0000000E+00	0.0000000E+00	2.0000000E+00	0.0000000E+00
VDataType	IS2	IS2	IS2	IS2
VUnit	Hz	Hz	EU	EU
VPlusOverData	?	?	?	?
VMinusOverData	?	?	?	?
VIllegalData	-32768	-32768	-32768	-32768
VMaxData	32767	32767	32767	32767
VMinData	-32767	-32767	-32767	-32767
HResolution	2.0000000E-04	2.0000000E-04	2.0000000E-04	2.0000000E-04
HOffset	-2.0018000E+00	-2.0018000E+00	-2.0018000E+00	2.0018000E+00
HUnit	s	s	s	s
Date	2004/1/15	2004/1/15	2004/1/15	2004/1/15
Time	14:25:38.54	14:25:38.54	14:25:38.54	14:25:38.54

### \$Group4

TraceNumber	1
BlockNumber	1
TraceName	EVENT
BlockSize	10010
VResolution	1.0000000E+00
VOffset	0.0000000E+00
VDataType	B16
VUnit	?
VPlusOverData	?
VMinusOverData	?
VIllegalData	?
VMaxData	32767
VMinData	-32767
HResolution	2.0000000E-04
HOffset	-2.0018000E+00
HUnit	s
Date	2004/1/15
Time	14:25:38.54

\$PrivateInfo				
DisplayPointNo.	1	1	1	1
	1	1	1	1
	1	1	1	1
	1			
MathBlockNo.	1			
ModelVersion	3.1			
PTraceName	CH1	CH2	CH3	CH4
	CH5	CH6	CH7	CH8
	CH15	CH16	Math1	Math2
	Voice,,,,,,,,,	D-Cap,,,,,,,,,		
PUpperScaleData	6.00E+00	250.0V	250.00V	250.00V
	25.000V	25.000V	25.000V	25.000V
	5000.0Hz	5000.0Hz	4.50000E+00EU	250.000E-03EU
PLowerScaleData	-4.00E+00	-250.0V	-250.00V	-250.00V
	-25.000V	-25.000V	-25.000V	-25.000V
	-5000.0Hz	-5000.0Hz	-500.000E-03EU	250.000E-03EU
POffsetName	0.00000V	0.00000V	0.00000V	0.00000V
	0.00000V	0.00000V	0.00000V	0.00000V
	0.00000Hz	0.00000Hz		

**Note**

The same header file format is used by all YOKOGAWA measuring instruments, so it may contain some data which are not necessary for the instrument.

**\$PublicInfo (Common Information)**

FormatVersion: Header file version No. (common to YOKOGAWA's header files)  
Model: Model name  
Endian: Endian mode when saving data (Big/Ltl)<sup>\*1</sup>  
DataFormat: Storage format of the binary waveform data (Trace/Block)<sup>\*2</sup>  
GroupNumber: The number of "\$Group"s indicated below  
TraceTotalNumber: Total number of selected waveforms  
DataOffset: Start position of the binary waveform data<sup>\*3</sup>

**\$Group1 (Group Information)**

TraceNumber: Number of waveforms in this group  
BlockNumber: Number of blocks in this group<sup>\*4</sup>  
TraceName: Name of each waveform  
BlockSize: Number of data points in a single block of each waveform  
VResolution: Value of coefficient VResolution of the Y-axis conversion equation of each waveform<sup>\*5</sup>  
VOffset: Value of coefficient VOffset of the Y-axis conversion equation of each waveform<sup>\*5</sup>  
VDataType: Type of binary file waveform data for each waveform<sup>\*6</sup>  
VUnit: Unit used on the Y-axis of each waveform (no effect on the data)  
VPlusOverData: Error data when the binary data of each waveform is greater than or equal to this value  
VMinusOverData: Error data when the binary data of each waveform is less than or equal to this value  
VMaxData: Maximum value of binary data for each waveform  
VMinData: Minimum value of binary data for each waveform  
HResolution: Value of coefficient HResolution of the X-axis conversion equation of each waveform<sup>\*7</sup>  
HOffset: Value of coefficient HOffset of the X-axis conversion equation of each waveform<sup>\*7</sup>  
HUnit: Unit used on the X-axis of each waveform (no effect on the data)  
Date: Date when a trigger is activated  
Time: Time when a trigger is activated

For details on \*1 to \*7, see the next page.

**\$PrivateInfo (Model-Specific Information)**

ModelVersion: Version No. of the instrument  
MathBlockNo.: Block No. of block to be computed  
DisplayPointNo.: Value which indicates which point of the memory is the left end of the display record length  
PTraceName: Label for each waveform  
PUpperScaleData: Scale value of the top edge of the screen  
PLowerScaleData: Scale value of the bottom edge of the screen  
POffsetName: Offset value

## Creation of ASCII Header File

When waveform data (Waveform) is stored on a storage medium (such as a floppy disk, a Zip disk, or a PC card), the following two files will be created automatically in the DL\_WAVE directory.

- Waveform display data file (.wvf)
- ASCII header file (.hdr)

The waveform data file can be recalled to the instrument using the file menu. The ASCII header files explained here cannot be viewed on the DL750/DL750P. Use the data such as when analyzing the waveforms on your PC.

### \*1 Endian Mode When Saving Data

Big: Motorola 68000-family data

Ltl: Intel 86 family data

### \*2 Storage Format of the Binary Waveform Data

Trace: Groups into blocks, each block for a single waveform.

Block: Groups into blocks, each block for a given time interval.

Trace is used on the DL750/DL750P.

### \*3 Binary File Start Position

Offset from the beginning of the file

### \*4 Maximum Number of Blocks in the Group

Maximum number of blocks applies if the number of blocks varies between waveforms.

### \*5 Y Axis Conversion Equation for Each Waveform

Y-axis value = VResolution  $\times$  raw data + VOffset

### \*6 Data Type

ISn: n-byte signed integer

IUn: n-byte unsigned integer

FSn: n-byte signed real number

FUn: n-byte unsigned real number

Bm: m-bit data

### \*7 X Axis Conversion Equation for Each Waveform

X axis value = HResolution  $\times$  (Data No. - 1) + HOffset

# Appendix 5 User-Defined Computation

## Digital Filter

### Type

Type	Bandwidth
Gaussian	LowPass
Sharp	LowPass/HighPass/BandPass
IIR (Butterworth)	LowPass/HighPass/BandPass

### Filter Order

See the following table for the filter orders

		2%	5%	10%	20%	30% (Cutoff)
Gauss	LowPass	49	21	9	5	5
Sharp	LowPass	88	36	18	9	8
	HighPass	159	65	33	17	13
IIR	LowPass	4	4	4	3	2
	HighPass	4	4	4	4	3

### Filter Characteristics

Filter	Pass-band Ripple	Attenuation Slope	Attenuation at the Stop-band	Phase
Gauss	0dB	1	–	Linear phase
Sharp	±0.3 dB	–40 dB at 1 oct (Lowpass),	–40 dB	Linear phase
		–40 dB at –1oct (Highpass)		
IIR	0 dB	–5 dB at 1/6 oct (Lowpass),	–	Not linear phase
		–20 dB at –1 oct (Highpass)		

1. For Gaussian filter :  $-3.0 \times (f/f_c) 2 \text{ dB}$  (f : frequency,  $f_c$  : cutoff frequency)

### Frequency Characteristics of Filters

f: Sampling frequency (Hz)

Gauss(Cutoff: 10%)

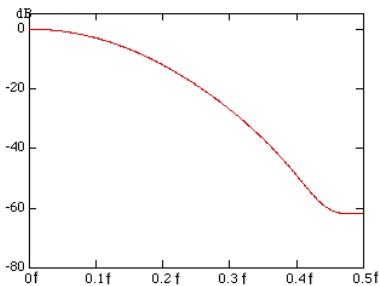

Sharp(Low Pass, Cutoff: 10%)

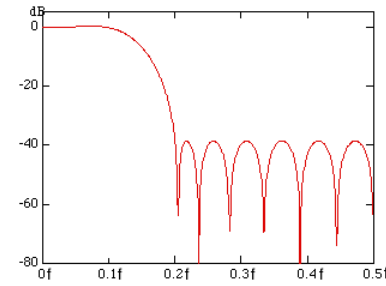

IIR(Low Pass, Cutoff: 10%)

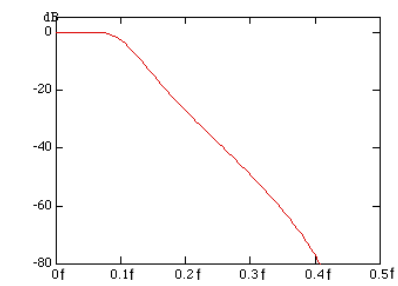

### Note

The higher the filter order the longer it takes for computation.

## Hilbert Function (HLBT)

Normally, when we analyze a real time signal, it is convenient to think of this signal as the real part of a complex function and do the actual analysis using the complex function. If the real time signal is considered to be the real part of the function, the imaginary part can be determined with the Hilbert transform of the real part.

The Hilbert transform does not change the order of the individual variables. Hilbert transform of a time signal results in another time signal.

Hilbert transform is described below.

When transforming a signal in the time domain, the signal is transformed into the frequency domain, first, using the Fourier transform. Next, the phase of each frequency component is shifted by  $-90$  deg if the frequency is positive and  $+90$  deg if negative. Lastly, taking the inverse Fourier transform completes the Hilbert transform.

### Application Example

- Hilbert transform can be used to analyze an envelope waveform.  
 AM (amplitude modulation):  $\text{SQRT}(C1 * C1 + \text{HLBT}(C1) * \text{HLBT}(C1))$   
 Demodulation of a FM signal:  $\text{DIF}(\text{PH}(C1, \text{HLBT}(C1)))$

## Phase Function (PH)

Phase function  $\text{PH}(X1, Y1)$  computes  $\tan^{-1}(X1/Y1)$ .

However, the phase function takes the phase of the previous point into consideration and continues to sum even when the value exceeds  $\pm\pi$  (ATAN function reflects at  $\pm\pi$ ).

The unit is radians.

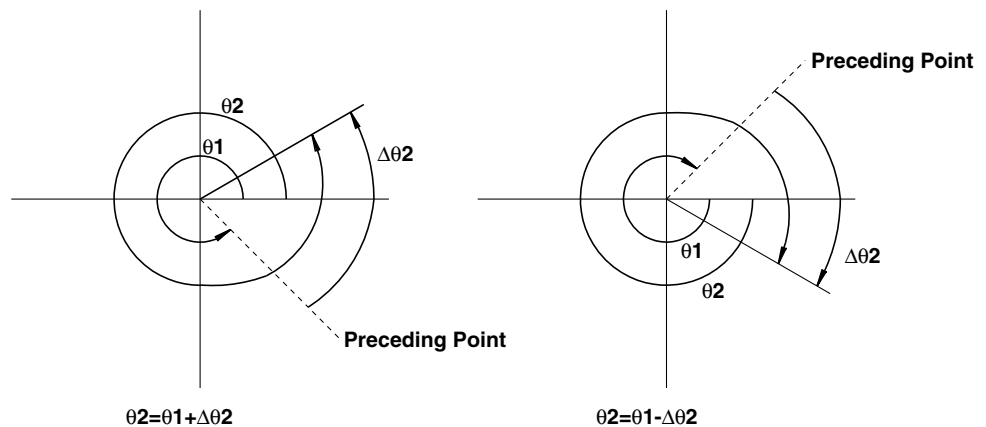



## Differentiation and Integration (DIF, DDIF, INTG, and IINTG)

### Differentiation (DIF, DDIF)

The computation of the first order and second order differentiation uses the 5th order Lagrange interpolation formula to derive a point of data from the 5 points around the point.

The figure below shows data  $f_0$  to  $f_n$  with respect to sampling time  $x_0$  to  $x_n$ . The derivative and integrated value corresponding to these data points are computed as follows:

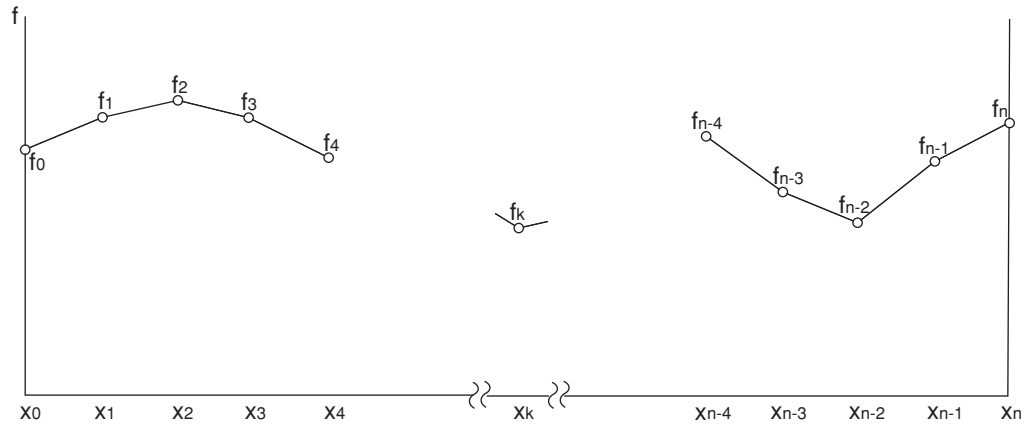

- **Equation for First Order Derivative**

$$\text{Point } x_0 \quad f_0' = \frac{1}{12h} [-25f_0 + 48f_1 - 36f_2 + 16f_3 - 3f_4]$$

$$\text{Point } x_1 \quad f_1' = \frac{1}{12h} [-3f_0 - 10f_1 + 18f_2 - 6f_3 + f_4]$$

$$\text{Point } x_2 \quad f_2' = \frac{1}{12h} [f_0 - 8f_1 + 8f_3 - f_4]$$

$$\text{Point } x_k \quad f_k' = \frac{1}{12h} [f_{k-2} - 8f_{k-1} + 8f_{k+1} - f_{k+2}]$$

$$\text{Point } x_{n-2} \quad f_{n-2}' = \frac{1}{12h} [f_{n-4} - 8f_{n-3} + 8f_{n-1} - f_n]$$

$$\text{Point } x_{n-1} \quad f_{n-1}' = \frac{1}{12h} [-f_{n-4} + 6f_{n-3} - 18f_{n-2} + 10f_{n-1} + 3f_n]$$

$$\text{Point } x_n \quad f_n' = \frac{1}{12h} [3f_{n-4} - 16f_{n-3} + 36f_{n-2} - 48f_{n-1} + 25f_n]$$

$h = \Delta x$  is the sampling interval (s) (example  $h = 200 \times 10^{-6}$  for 5 kHz)

- **Equation for Second Order Derivative**

$$\text{Point } x_0 \quad f_0'' = \frac{1}{12h^2} [35f_0 - 104f_1 + 114f_2 - 56f_3 + 11f_4]$$

$$\text{Point } x_1 \quad f_1'' = \frac{1}{12h^2} [11f_0 - 20f_1 + 6f_2 + 4f_3 - f_4]$$

$$\text{Point } x_2 \quad f_2'' = \frac{1}{12h^2} [-f_0 + 16f_1 - 30f_2 + 16f_3 - f_4]$$

$$\text{Point } x_k \quad f_k'' = \frac{1}{12h^2} [-f_{k-2} + 16f_{k-1} - 30f_k + 16f_{k+2} - f_{k+2}]$$

$$\text{Point } x_{n-2} \quad f_{n-2}'' = \frac{1}{12h^2} [-f_{n-4} + 16f_{n-3} - 30f_{n-2} + 16f_{n-1} - f_n]$$

$$\text{Point } x_{n-1} \quad f_{n-1}'' = \frac{1}{12h^2} [-f_{n-4} + 4f_{n-3} + 6f_{n-2} - 20f_{n-1} + 11f_n]$$

$$\text{Point } x_n \quad f_n'' = \frac{1}{12h^2} [11f_{n-4} - 56f_{n-3} + 114f_{n-2} - 104f_{n-1} + 35f_n]$$

**Integration (INTG, IINTG)**

The first and second order integrated values are derived using the trapezoidal rule.

• **Equation for First Order Integration (INTG)**

Point  $x_0$   $l_0$  = 0

Point  $x_1$   $l_1$  =  $\frac{1}{2}(f_0 + f_1)h$

Point  $x_2$   $l_2$  =  $\frac{1}{2}(f_0 + f_1)h + \frac{1}{2}(f_1 + f_2)h = l_1 + \frac{1}{2}(f_1 + f_2)h$

Point  $x_n$   $l_n$  =  $l_{n-1} + \frac{1}{2}(f_{n-1} + f_n)h$

• **Equation for Second Order Integration (IINTG)**

Point  $x_0$   $ll_0$  = 0

Point  $x_1$   $ll_1$  =  $\frac{1}{2}(l_0 + l_1)h$

Point  $x_2$   $ll_2$  =  $\frac{1}{2}(l_0 + l_1)h + \frac{1}{2}(l_1 + l_2)h = ll_1 + \frac{1}{2}(l_1 + l_2)h$

Point  $x_n$   $ll_n$  =  $ll_{n-1} + \frac{1}{2}(l_{n-1} + l_n)h$

**Binary Conversion (BIN)**

Performs binary conversion with respect to the specified threshold level.

For the procedure in setting the threshold level, see section 10.2, "Binary Computation."

BIN(C1)

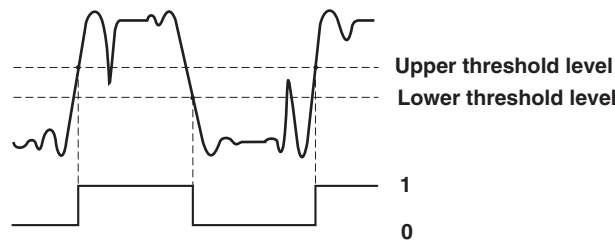

### Pulse Width Computation

The signal is converted to binary values by comparing to a preset threshold level, and the time of the pulse width is plotted as the Y-axis value for that interval.

The following 4 intervals are available.

PWHL From the rising edge to the next falling edge.

PWLH From the falling edge to the next rising edge.

PWLL From the falling edge to the next falling edge.

PWXX From the rising or falling edge to the next rising or falling edge.

FV Inverse of PWHL

#### Example When the Interval Is Set to PWHL

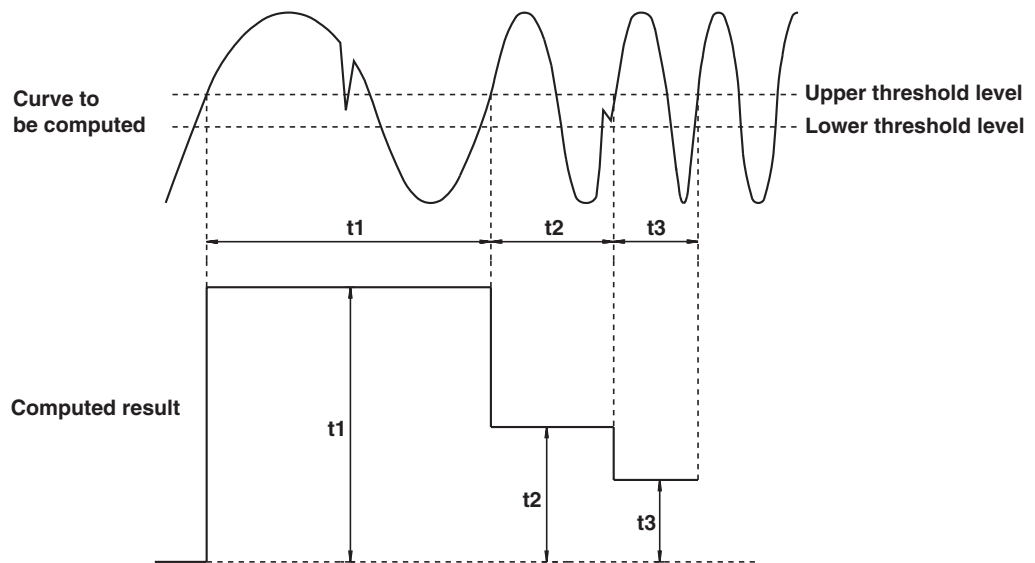

### FFT Function

Each frequency component  $G$  of a linear spectrum is represented by  $G=R+jI$  ( $R$ : real part,  $I$ : imaginary part).

#### Linear Spectrum

Linear spectrum is a spectrum that can be directly determined with the FFT. The magnitude and phase of each frequency component included in the measured waveform can be found. The power spectrum and cross spectrum can also be determined from one or two linear spectrums.

Because the FFT is a complex function, the linear spectrum produces the real part and imaginary part of the frequency components. The magnitude and phase of the linear spectrum can also be determined from the result.

The following spectrums can be determined with this instrument.

Item	Equation	Computation
Real part	LS-REAL	R
Imaginary part	LS-IMAG	I
Magnitude	LS-MAG	$\sqrt{(R^2+I^2)}$
Log magnitude	LS-LOGMAG	$20 \times \log \sqrt{(R^2+I^2)}$
Phase	LS-PHASE	$\tan^{-1}(I/R)$

Log magnitude reference (0 dB): 1 Vpeak

**Power Spectrum**

Power spectrum expresses the power (squared value) of each frequency component included in the measured signal. It is determined by taking the product of the linear spectrum and its complex conjugate. It does not contain phase information. The following spectrums can be determined with this instrument.

Item	Equation	Computation
Magnitude	PS-MAG	$(R^2+I^2)/2$
Log magnitude	PS-LOGMAG	$10*\log(R^2+I^2)/2$

Log magnitude reference (0 dB): 1 Vrms<sup>2</sup>

**Power Spectrum Density**

Power spectrum density expresses the power spectrum per unit frequency. It is determined by dividing the power spectrum by the frequency resolution Δf found during the analysis of the power spectrum. The computation varies depending on the window function.

Power spectrum density is used to compare power spectrums analyzed at different frequency bands. However, it is not necessary for signals having a line spectrum such as sine waves.

The following spectrums can be determined with this instrument.

Item	Equation	Computation
Magnitude	PSD-MAG	PS-MAG/Δf (for rectangular window) PS-MAG/1.5Δf (for Hanning window)
Log magnitude	PSD-LOGMAG	10 × logPS-MAG/Δf (for rectangular window) 10 × logPS-MAG/1.5Δf (for Hanning window)

Log magnitude reference (0 dB): 1 Vrms<sup>2</sup>

**Overall Value**

The overall value is the total RMS value determined from the frequency spectrum included in the signal. The overall value is determined by summing the power spectrum of all frequencies and then taking the square root.

$$\text{Overall Value} = \sqrt{\frac{2 \times \text{PS}_0 + \sum \text{PS}_i}{k}} \text{ (Vrms)}$$

The k value varies depending on the selected time window as follows:

Time Window Type	k
Rect (Rectangular)	1
Hanning	1.5
Flattop	3.19693

If the channels (Math1 to Math8) on which power spectrum computation (PS or PSD\*) is selected are in the middle of the automated measurement of waveform parameters (MEASURE: ON) and Rms is ON, the screen shows "Rms = overall value." However, the overall value is not displayed when the time window is set to Exponential.

**Cross Spectrum**

Cross spectrum is determined from 2 signals. It is found by taking the product of the linear spectrum of one signal ( $G_x$ ) and the complex conjugate ( $G_y^*$ ) of the linear spectrum of the other signal ( $G_y$ ).

If the linear spectrums of the 2 signals are represented by

$$G_x = R_x + jI_x$$

$$G_y = R_y + jI_y$$

then the cross spectrum  $G_{yx}$  is

$$G_{yx} = G_y \times G_x^* \\ = (R_y + jI_y)(R_x - jI_x) = R_{yx} + jI_{yx}$$

$$\text{where } R_{yx} = R_y R_x + I_y I_x$$

$$I_{yx} = R_x I_y - R_y I_x$$

The following spectrums can be determined with this instrument.

Item	Equation	Computation
Real part	CS-REAL	$R_{yx}/2$
Imaginary part	CS-IMAG	$I_{yx}/2$
Amplitude	CS-MAG	$\sqrt{(R_{yx}^2 + I_{yx}^2)}/2$
Log magnitude	CS-LOGMAG	$10 \times \log(\sqrt{(R_{yx}^2 + I_{yx}^2)}/2)$
Phase	CS-PHASE	$\tan^{-1}(I_{yx}/R_{yx})$

**Transfer Function**

The transfer function expresses the frequency characteristics between the input to the transfer system and the output. The transfer function is determined by the ratio of the output linear spectrum ( $G_y$ ) and the input spectrum ( $G_x$ ) at each frequency. Also, as can be seen from the next equation, the transfer function can be defined as the ratio of the cross spectrum of the input and output ( $G_{yx}$ ) and the input power spectrum ( $G_{xx}$ ).

$$\text{Transfer Function} = G_y/G_x = (G_y \times G_x^*) / (G_x \times G_x^*) = G_{yx}/G_{xx} \\ = (R_{yx} + jI_{yx}) / (R_x^2 + I_x^2)$$

The following items can be determined with this instrument.

Item	Equation	Computation
Real part	TF-REAL	$R_{yx}/(R_x^2 + I_x^2)$
Imaginary part	TF-IMAG	$I_{yx}/(R_x^2 + I_x^2)$
Amplitude	TF-MAG	$\sqrt{(R_{yx}^2 + I_{yx}^2)}/2 / (R_x^2 + I_x^2)$
Log magnitude	TF-LOGMAG	$20 \times \log(\sqrt{(R_{yx}^2 + I_{yx}^2)}/2 / (R_x^2 + I_x^2))$
Phase	TF-PHASE	$\tan^{-1}(I_{yx}/R_{yx})$

The magnitude of the transfer function shows the ratio of the magnitudes of the output linear spectrum and the input linear spectrum while the phase shows the phase difference of the two.

**Coherence Function**

This expresses the ratio of the output power generated with the input signal to the transfer system and the total output power.

$$\text{Coherence function} = G_{yx} \times G_y^* / (G_{xx} \times G_{yy})$$

Item	Equation	Computation
Magnitude	CH-MAG	$(R_{yx}^2 + I_{yx}^2) / (G_{xx} \times G_{yy})$

If the output signal is due entirely to the input signal, the coherence function becomes 1. As the ratio decreases, it falls below 1. Thus, the coherence function always takes on a value between 0 and 1.

**Note**

On one data acquisition, the coherence function becomes 1 across all frequencies. Also, make sure to take the frequency average of the computation.

**Time Windows**

You can select rectangular, Hanning, flattop, or exponential for the time window. The rectangular window is best suited to transient signals, such as an impulse wave, which attenuate completely within the time window. The Hanning and flattop windows allow continuity of the signal by gradually attenuating the parts of the signal located near the ends of the time window down to the 0 level. Hence, it is best suited to continuous signals. With the Hanning window, the frequency resolution is relatively high as compared with the flattop window. However, the flattop window has a higher level of accuracy. When the waveform being analyzed is a continuous signal, consider the above characteristics in selecting the proper window to be applied.

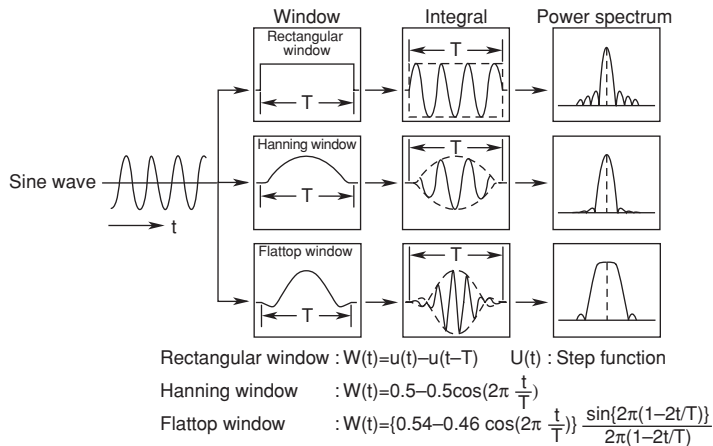

The exponential window is used to eliminate noise components from the signal. It is effective against signals such as the frequency response test signal generated through impulse excitation. On the DL750/DL750P, the exponential window and force window are activated simultaneously.

• **Exponential Window**

The damping rate is set in terms of the weight of the last data point when taking the weight of the first data point in the specified number of FFT points to be 100% (= 1). The value is set in the range of 1 to 100% (1% resolution). The exponential window damps the signal exponentially along the time axis. It is effective when the signal does not attenuate all the way within the record length. If the damping rate is set to 100%, the window is equivalent to a rectangular window.

• **Force Window**

Sets the area over which computation performed in terms of a percentage from the first FFT point when taking the specified number of FFT points to be 100%. The areas (force 1 and force 2) can be set in the range of 1 to 100% (1% resolution) of the input/output signal. If the area is set to 100%, the window is equivalent to a rectangular window. On the DL750/DL750P, the data outside the area is computed as an average value of the area.

Force1: The setting applies to the input signal (first parameter) of the one-input FFT or two-input FFT.

Force2: The setting applies to the output (response) signal (second parameter) of the two-input FFT.

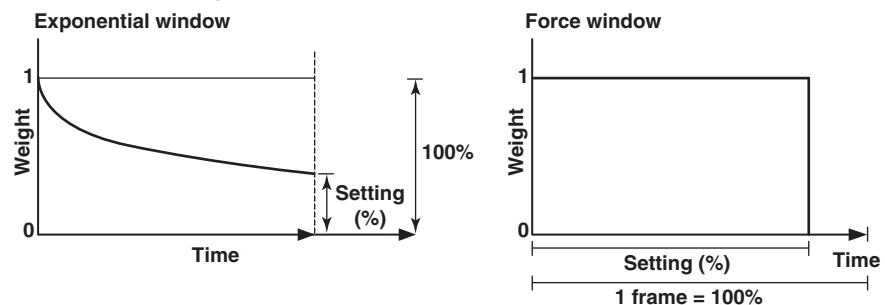

- **Combined Form of Exponential Window and Force Window**

The DL750/DL750P applies a window function that combines the exponential window and force window for performing computations. The data outside the force window area are computed as an average value of the area.

When the force window area is set to 80% and the data outside the area is taken into account

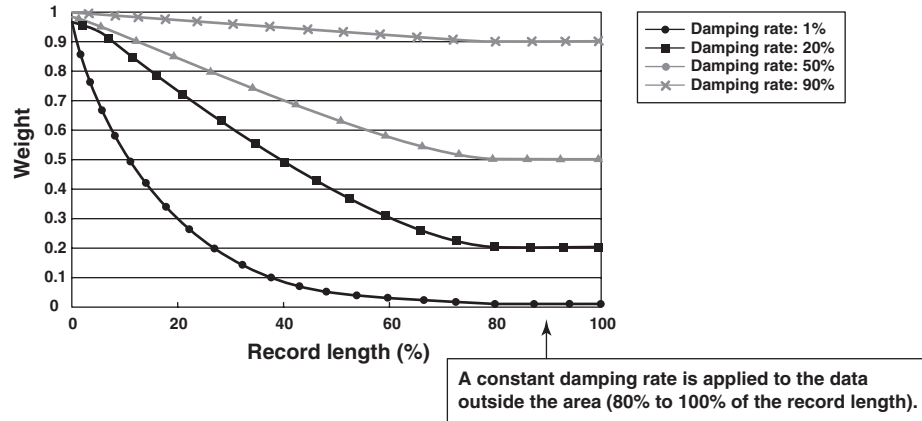

- **Application Example on the DL750/DL750P**

When the damping rate is set to 20% and force 1 is set to 80%

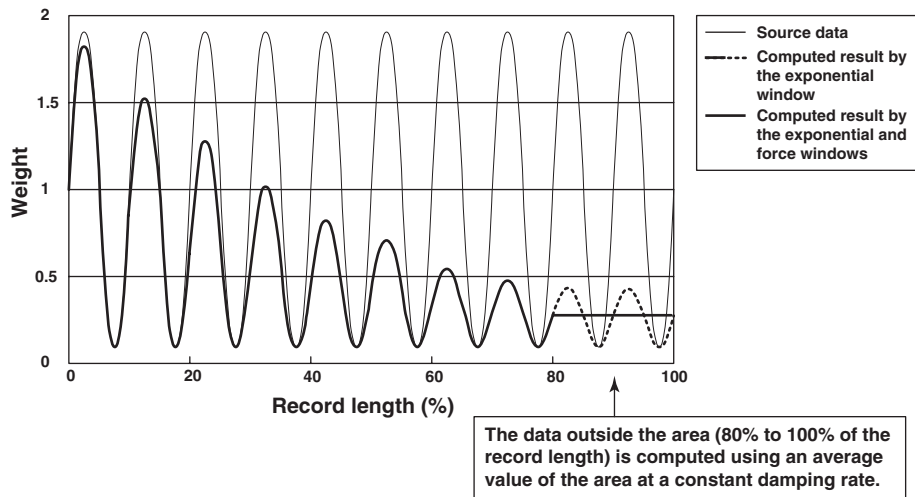

**Notes When Executing the FFT Computation**

Normally, computation is performed on the sampled data stored in the acquisition memory. However, for waveforms that have been acquired in envelope mode, computation is performed on the maximum/minimum values per acquisition interval.

# Appendix 6 DSP Channel Computation (Optional)

## Digital Filter Computation of DSP Channels

### Filter Types

On DSP channels, the following two types of digital filter computation can be performed.

- FIR
- IIR

#### • FIR

FIR digital filter. The signal block diagram of the computation is shown below. The characteristics of FIR filters are as follows.

1. Achieves steep high-order filter within the allowed computation time. However, computation delay increases as the order increases.
2. Group delay is constant due to its linear phase characteristics. Therefore, phase distortion is small.

DSP channels can use the following FIR filters.

- SHARP
- GAUSS
- MEAN (moving average)

### Signal Block Diagram of an FIR Filter

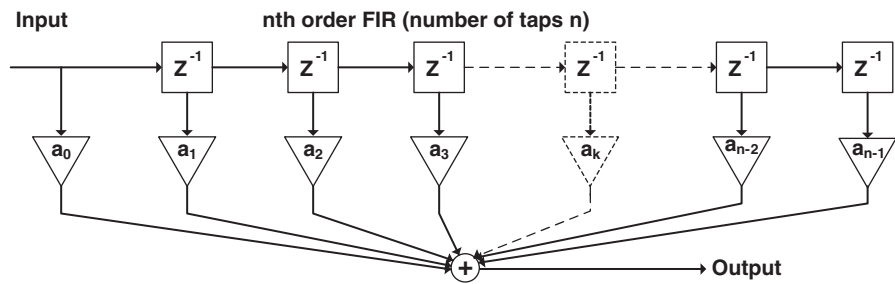

#### • IIR

IIR digital filter. The signal block diagram of the computation is shown below. The characteristics of IIR filters are as follows.

1. Sufficient cutoff characteristics are obtained even at a relatively low order. Therefore, the computation delay and group delay are smaller than those of FIRs.
2. The frequency can be set lower than FIRs.
3. Phase distortion is greater than FIR filters due to its non-linear phase characteristics.

DSP channels can use IIR (Butterworth) as an IIR filter.

### Signal Block Diagram of an IIR Filter

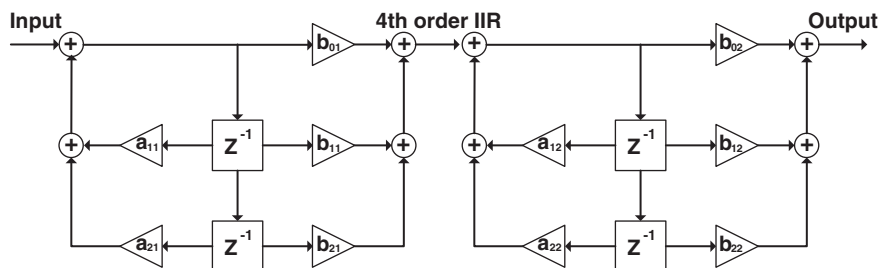



### Filter Characteristics

The characteristics of each filter are indicated below.

Type	Characteristics	Bandwidth	Computation Type
SHARP	Steep attenuation slope (–40 dB per octave) Linear phase and constant group delay Ripple exists in the passband Stop band is comb-shaped	LowPass HighPass BandPass	FIR
GAUSS	Gentle attenuation slope Linear phase and constant group delay No ripple in the passband There is no overshoot in the step response. Low order and small delay	LowPass	FIR
MEAN (moving average)	Comb-shaped characteristics Linear phase and constant group delay There is no overshoot in the step response.	LowPass	FIR
IIR (Butterworth)	Attenuation slope is between SHARP and GAUSS Not linear phase and group delay not constant No ripple in either passband or stopband Cutoff frequency can be set lower than SHARP/GAUSS Close to the characteristics of an analog filter	LowPass HighPass BandPass	IIR

Type	Pass-band Ripple	Attenuation Slope	Attenuation at the Stop-band	Phase	Selectable Cutoff Range
SHARP	0 dB	–40 dB/OCT (Low Pass)			
		–40 dB/OCT (High Pass)	–40 dB	Linear phase	2 to 30%
GAUSS	±0.3 dB	$-3.0 \times (f/f_c)^2$ dB	Linear phase	2 to 30%	
MEAN (moving average)	0 dB	See characteristics diagram		Linear phase	-
IIR (Butterworth)	0dB	–24 dB/OCT (Low Pass)			
		–24 dB/OCT (High Pass)		Not linear phase	0.2 to 30%

### Group Delay Characteristics

Group delay refers to the delay of the output frequency with respect to the input frequency (sine wave) due to the response characteristics of the filter. The group delay can be normalized using the sampling period (Ts), and the unit is s/Ts. The delay for each frequency can be derived from the equation (group delay of each frequency × sampling period).

#### Example

The group delay for moving average can be expressed as follows (constant regardless of the frequency).

Group delay for moving average [s/Ts] = (the number of moving average points – 1)/2  
If the number of moving average points is 16,

$$\text{Group delay [s/Ts]} = (16-1)/2 = 15/2 = 7.5 \text{ [s/Ts]}$$

If the sampling frequency (fs) is 100 [kHz],

$$T_s = 1/f_s = 1/(100 \text{ [kHz]}) = 10 \text{ [}\mu\text{s]}$$

Therefore,

$$\text{Delay} = \text{group delay} \times \text{sampling period} = 7.5 \text{ [s/Ts]} \times 10 \text{ [}\mu\text{s]} = 75 \text{ [}\mu\text{s]}$$

### Computation Delay

The processing time of the DSP channel inside the DL750/DL750P requires 4 sampling periods. Therefore, the delay of the actual digital filter is (4 sampling period) + (delay determined from the group delay characteristics).

## SHARP Filter

**Characteristics**• **Low-pass and high-pass**

- The ripple in the pass band is within 0.3 dB.
- The attenuation falls to  $-40$  dB at twice (low-pass) and  $1/2$  (high-pass) the cutoff frequency.
- The attenuation in the stop band is  $-40$  dB or greater.
- Has linear phase characteristics and constant group delay.

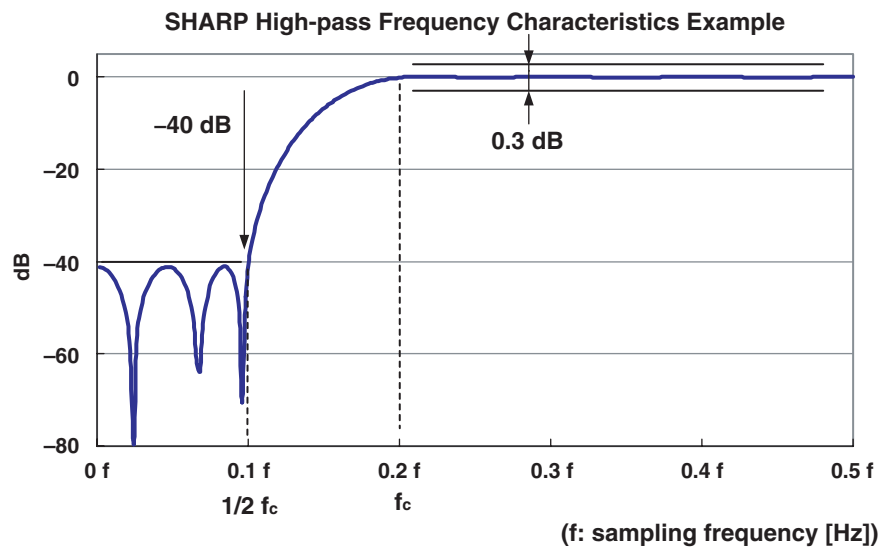
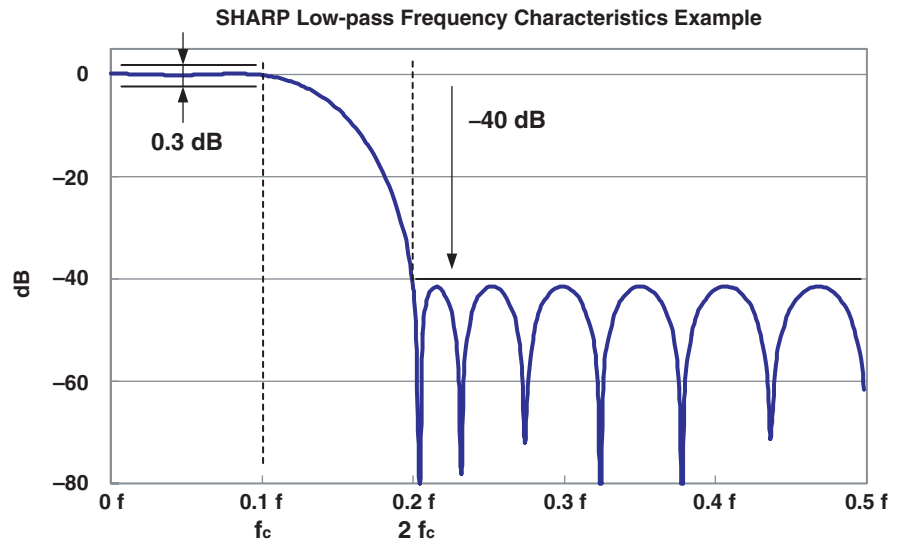

• **Bandpass**

- The ripple in the pass band is within 0.3 dB.
- In the low frequency region, the attenuation falls to -40 dB at 1/2 the frequency from the pass band edge  $f_{cl}$ .
- The width of the transition region from the pass band edge in the high frequency region to the -40 dB point is equal to the width of the transition region in the low frequency region.  
 $(f_{cl} - 1/2 f_{cl}) = f_{cus} - f_{cu}$
- The attenuation in the stop band is -40 dB or greater.
- Has linear phase characteristics and constant group delay.

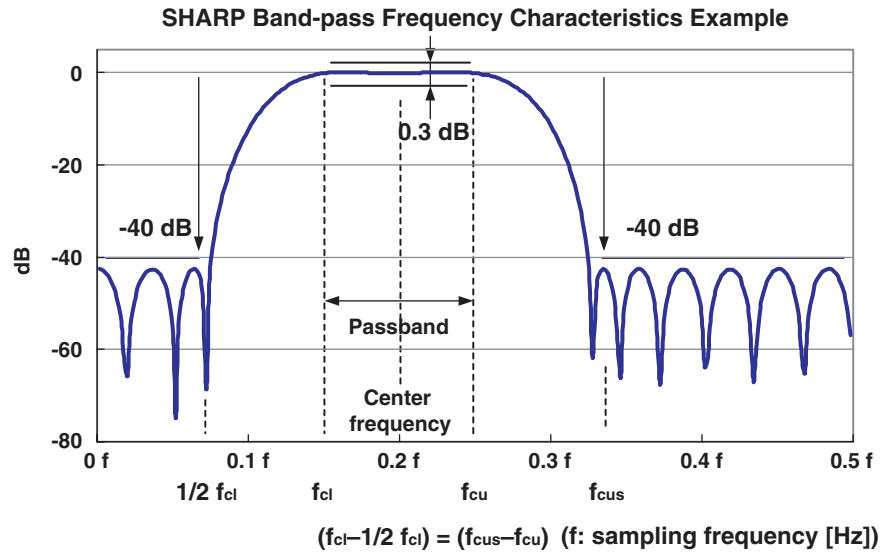

For SHARP band-pass filters, the center frequency that can be specified is limited by the pass-band width.

**Selectable Range of SHARP Bandpass Filter Frequency**

Passband Width Setting [%]	Lower Limit of Center Frequency [%] (Passband Region)	Upper Limit of Center Frequency [%] (Passband Region)
2	3 (2 to 4)	30 (29 to 31)
5	4.6 (2.1 to 7.1)	30 (27.5 to 32.5)
10	7 (2 to 12)	30 (25 to 35)
15	9.6 (2.1 to 17.1)	30 (22.5 to 37.5)
20	12 (2 to 22)	30 (20 to 40)

**Order Table**

See below for the SHARP filter orders.

**SHARP Low-pass Filter Order**

Cutoff frequency	2%	3%	4%	5%	6%	7%	8%	9%
Order	94	61	46	37	32	28	24	22
Cutoff frequency	10%	11%	12%	13%	14%	15%	16%	17%
Order	20	17	17	15	14	13	13	11
Cutoff frequency	18%	19%	20%	21%	22%	23%	24%	25%
Order	11	11	10	11	9	9	8	8
Cutoff frequency	26%	27%	28%	29%	30%			
Order	8	8	8	8	8			

**SHARP High-pass Filter Order**

Cutoff frequency	2%	3%	4%	5%	6%	7%	8%	9%
Order	191	127	97	77	65	55	49	45
Cutoff frequency	10%	11%	12%	13%	14%	15%	16%	17%
Order	39	37	33	31	29	27	25	25
Cutoff frequency	18%	19%	20%	21%	22%	23%	24%	25%
Order	23	23	21	21	19	19	19	17
Cutoff frequency	26%	27%	28%	29%	30%			
Order	17	17	15	15	15			

**SHARP Band-pass Filter Order Pass-band Width 2%**

Center frequency	3%	4%	5%	6%	7%	8%	9%	10%
Order	189	142	93	80	69	61	54	49
Center frequency	11%	12%	13%	14%	15%	16%	17%	18%
Order	45	41	37	34	32	27	20	18
Center frequency	24%	25%	26%	19%	20%	21%	22%	23%
Order	18	17	16	16	14	14	14	13
Center frequency	27%	28%	29%	30%				
Order	13	12	13	11				

**SHARP Band-pass Filter Order Pass-band Width 5%**

Center frequency	5%	6%	7%	8%	9%	10%	11%	12%
Order	154	112	93	72	64	58	51	40
Center frequency	13%	14%	15%	16%	17%	18%	19%	20%
Order	37	35	33	31	29	28	26	25
Center frequency	21%	22%	23%	24%	25%	26%	27%	28%
Order	24	23	22	21	20	19	19	18
Center frequency	29%	30%						
Order	17	18						

**SHARP Band-pass Filter Order Pass-band Width 10%**

Center frequency	7%	8%	9%	10%	11%	12%	13%	14%
Order	194	132	97	78	69	57	52	47
Center frequency	15%	16%	17%	18%	19%	20%	21%	22%
Order	39	37	35	33	31	30	28	27
Center frequency	23%	24%	25%	26%	27%	28%	29%	30%
Order	23	23	20	19	18	18	17	16

## Appendix 6 DSP Channel Computation (Optional)

### SHARP Band-pass Filter Order Pass-band Width 15%

Center frequency	10%	11%	12%	13%	14%	15%	16%	17%
Order	155	110	89	73	62	52	49	41
Center frequency	18%	19%	20%	21%	22%	23%	24%	25%
Order	38	36	34	32	27	26	25	24
Center frequency	26%	27%	28%	29%	30%			
Order	23	22	21	21	21			

### SHARP Band-pass Filter Order Pass-band Width 20%

Center frequency	12%	13%	14%	15%	16%	17%	18%	19%
Order	191	129	98	78	67	58	49	46
Center frequency	20%	21%	22%	23%	24%	25%	26%	27%
Order	40	38	36	31	29	28	27	26
Center frequency	28%	29%	30%					
Order	25	24	20					

### Computation Delay

The group delay can be derived from the following equation. It is constant and depends on the filter order.

$$\text{Group delay} = (\text{Filter order} - 1)/2$$

Unit:  $s/T_s$  (where  $T_s$  is the sampling frequency [s])

The computation delay can be derived from the following equation.

$$\text{Computation delay} = \{4 + (\text{filter order} - 1)/2\} \times \text{sampling period}$$

However, if the sampling frequency exceeds 100 kHz, it is fixed to 100 kHz (10  $\mu$ s).

It is also fixed to 100 kHz (10  $\mu$ s) when in envelope mode.

### Characteristics Examples

- SHARP Low-pass

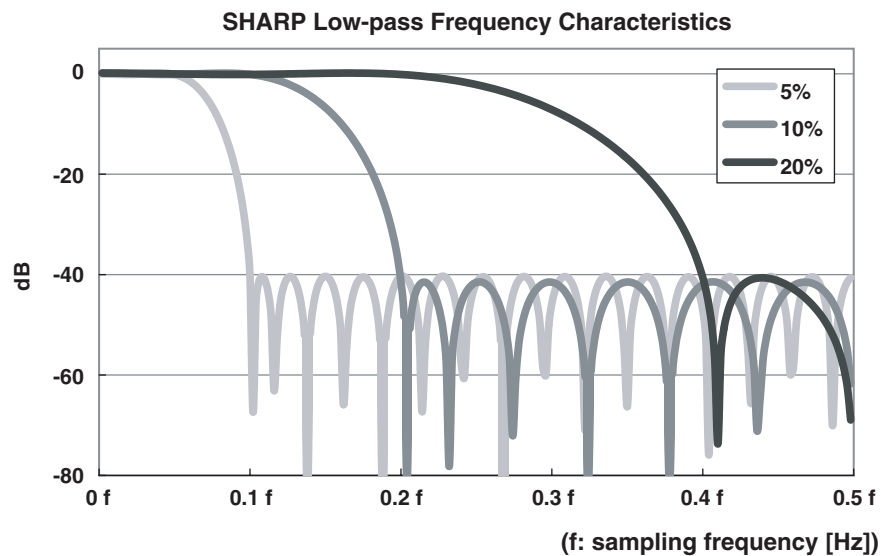

- SHARP High-pass

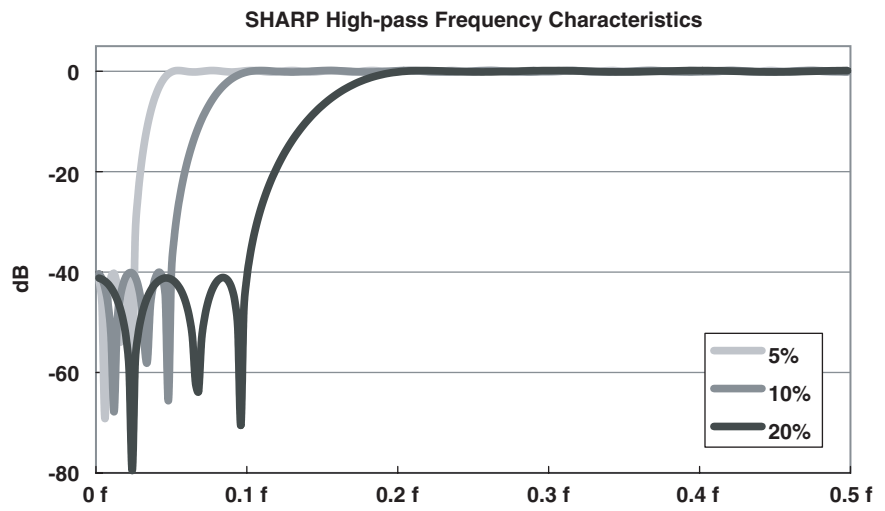

- SHARP Band-pass: Pass-band Width 2%

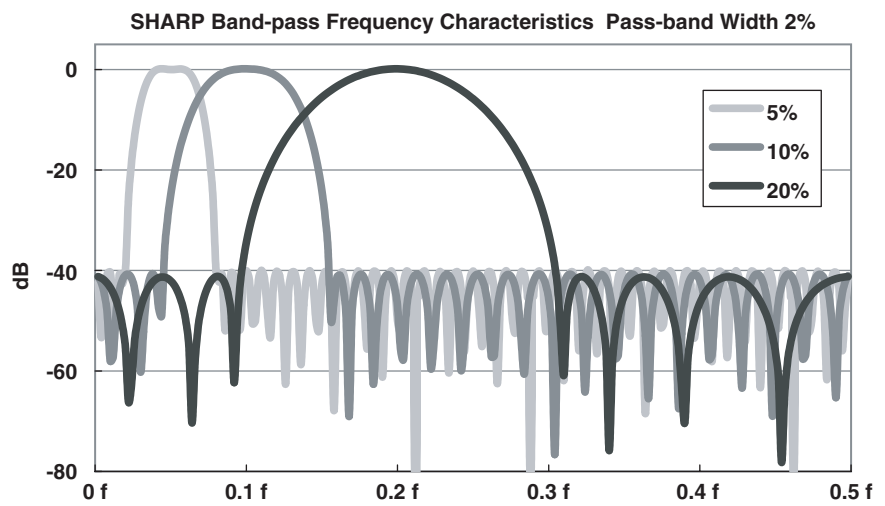

- SHARP Band-pass: Pass-band Width 5%

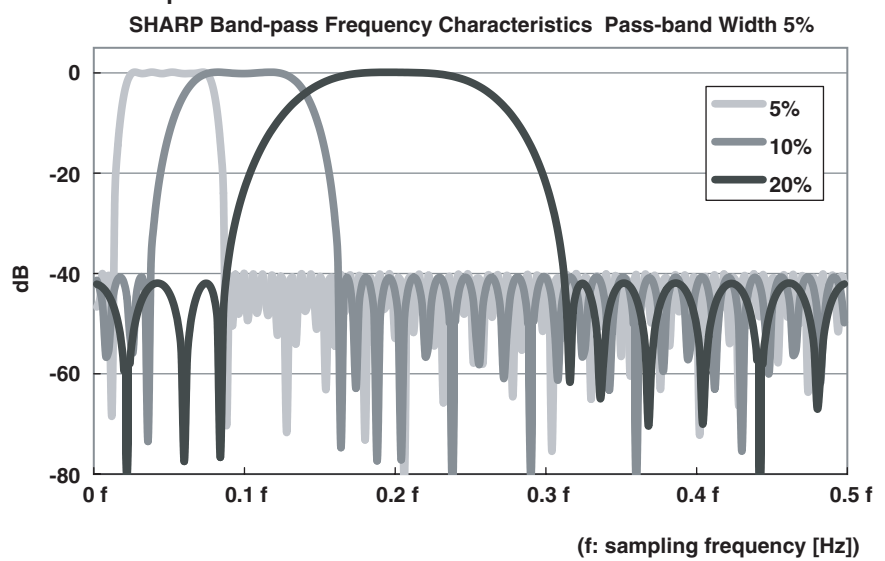

- SHARP Band-pass: Pass-band Width 10%

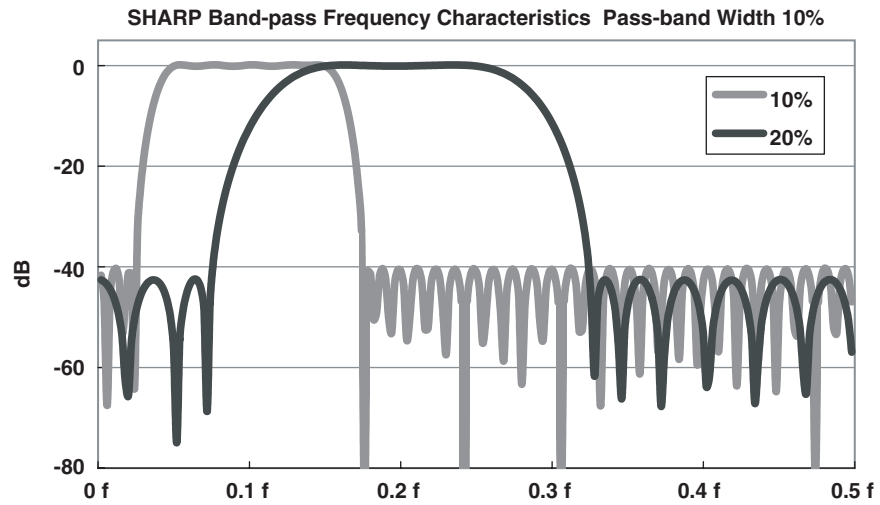

- SHARP Band-pass: Pass-band Width 15%

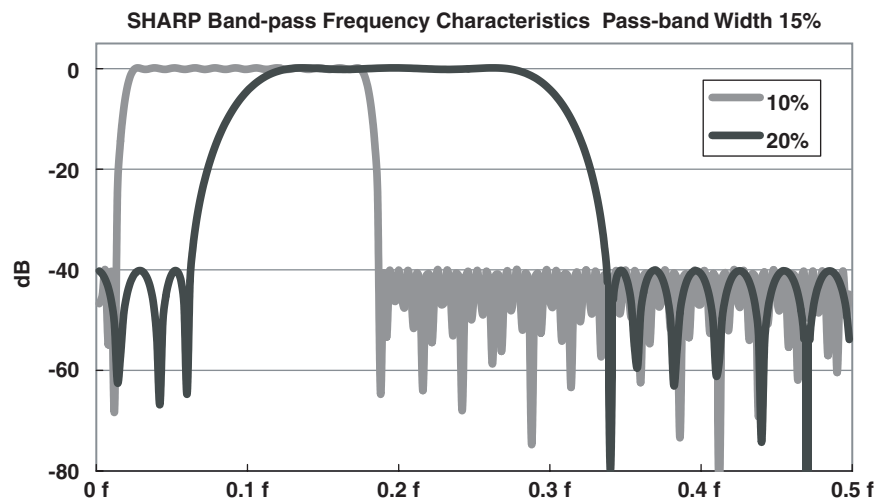

- SHARP Band-pass: Pass-band Width 20%

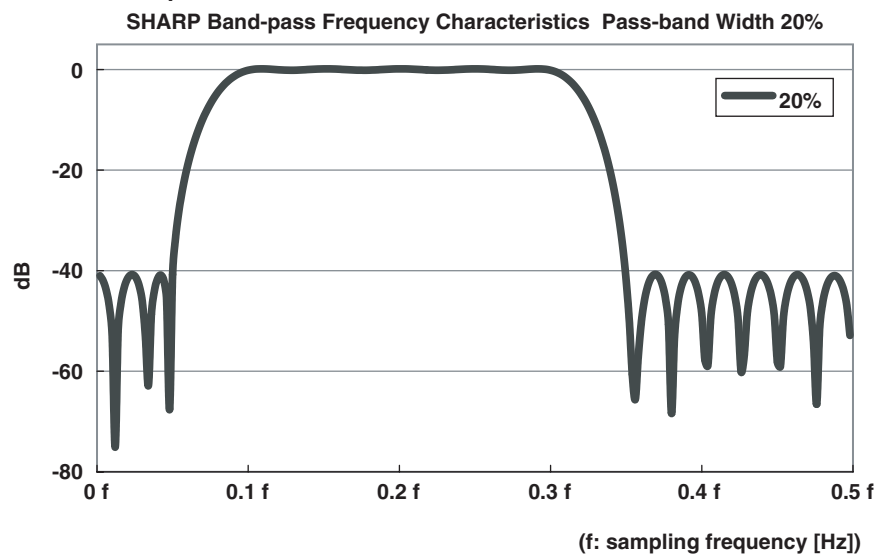

## GAUSS Filter

### Characteristics

- Pass band is flat.
- The attenuation is  $-3$  dB at the cutoff frequency.  
Attenuation is equal to  $-3.0 \times (f/f_c)^2$ .
- Has linear phase characteristics and constant group delay.
- Only low-pass filter can be specified.

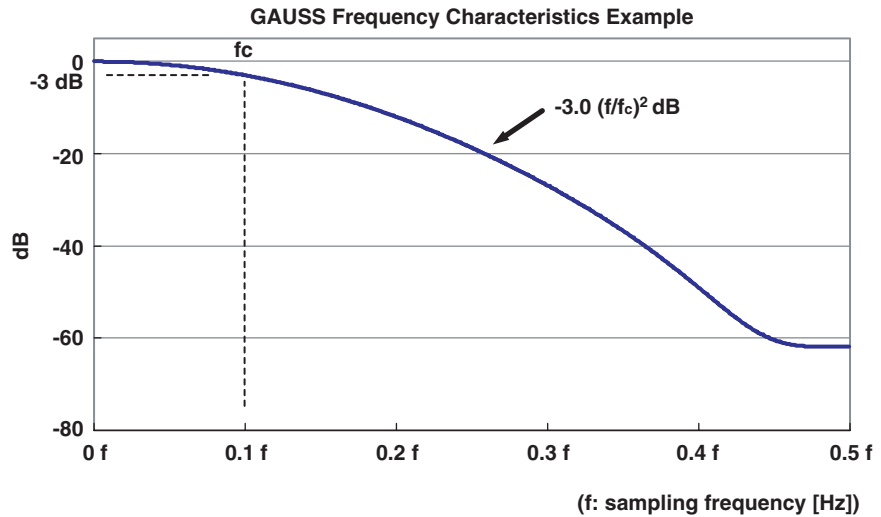

### Order Table

See below for the GAUSS filter orders.

#### GAUSS Filter Order

Cutoff frequency	2%	3%	4%	5%	6%	7%	8%	9%
Order	49	33	25	21	17	17	13	13
Cutoff frequency	10%	11%	12%	13%	14%	15%	16%	17%
Order	9	9	9	9	9	9	9	5
Cutoff frequency	18%	19%	20%	21%	22%	23%	24%	25%
Order	5	5	5	5	5	5	5	5
Cutoff frequency	26%	27%	28%	29%	30%			
Order	5	5	5	5	5			

### Computation Delay

The group delay can be derived from the following equation. It is constant and depends on the filter order.

$$\text{Group delay} = (\text{Filter order} - 1)/2$$

Unit:  $s/T_s$  (where  $T_s$  is the sampling frequency [s])

The computation delay can be derived from the following equation.

$$\text{Computation delay} = \{4 + (\text{filter order} - 1)/2\} \times \text{sampling period}$$

However, if the sampling frequency exceeds 100 kHz, it is fixed to 100 kHz (10  $\mu$ s). It is also fixed to 100 kHz (10  $\mu$ s) when in envelope mode.



**Characteristics Examples**

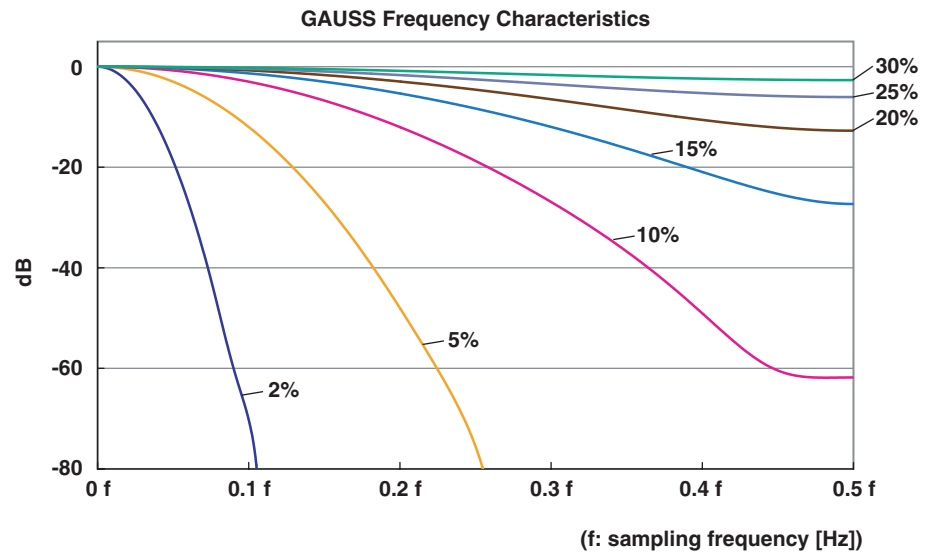

## IIR (Butterworth) Filter

### Characteristics

- **Low-pass and high-pass.**
  - 4th order Butterworth filter. Attenuation is approximately  $-24$  dB/OCT.
  - Pass band is flat.
  - The attenuation falls to  $-3$  dB at the cutoff frequency.
  - Has non-linear phase characteristics.
  - Lower frequencies can be specified as compared to other FIR filters.

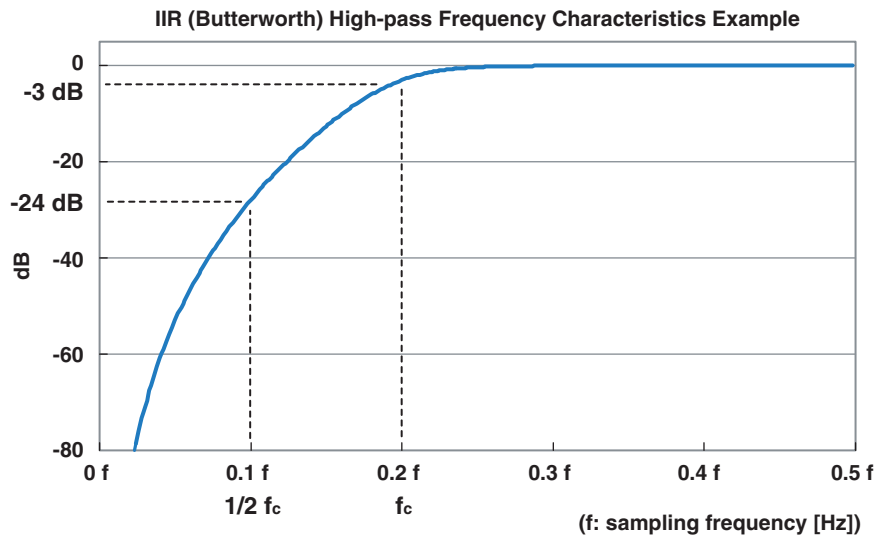
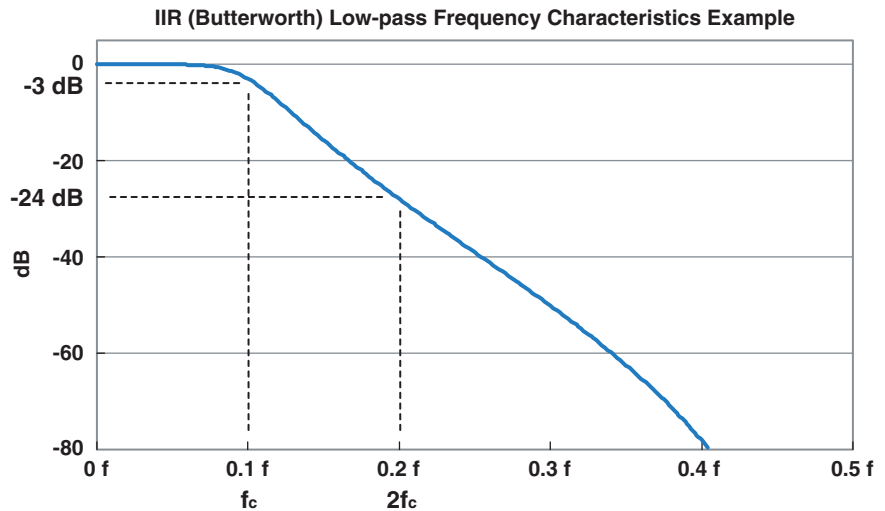

- **Band Pass**
  - Pass band is flat.
  - The attenuation falls to  $-3$  dB at each end of the pass band.
  - 4th order Butterworth. No ripple in the stop band. For the cutoff characteristics, see the characteristics examples.
  - Has non-linear phase characteristics.
  - Lower frequencies can be specified as compared to SHARP filters.

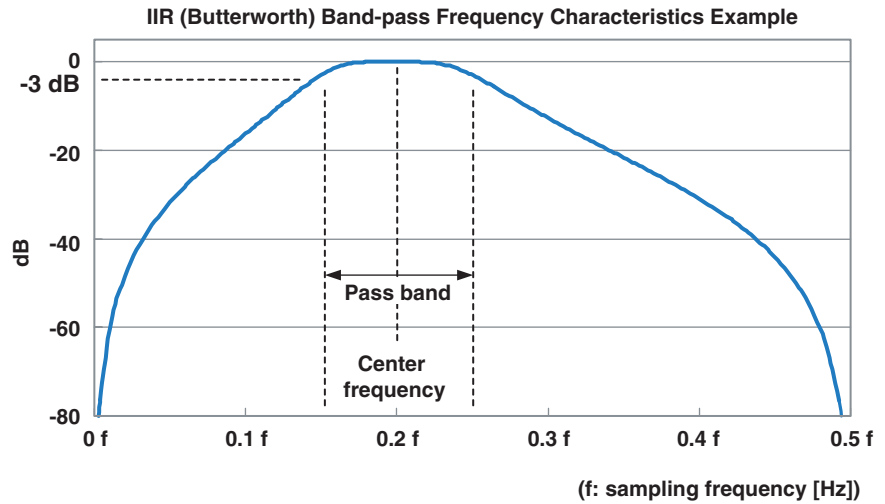

For IIR (Butterworth) band-pass filters, the center frequency that can be specified is limited by the pass-band width.

**Selectable Range of IIR (Butterworth) Bandpass Filter Frequency**

Passband Width Setting [%]	Lower Limit of Center Frequency [%] (Passband Region)	Upper Limit of Center Frequency [%] (Passband Region)
1	0.6 (0.1 to 1.1)	30 (29.5 to 30.5)
2	1.2 (0.2 to 2.2)	30 (29 to 31)
5	2.6 (0.1 to 5.1)	30 (27.5 to 32.5)
10	5.2 (0.2 to 10.2)	30 (25 to 35)
15	7.6 (0.1 to 15.1)	30 (22.5 to 37.5)
20	10.2 (0.2 to 20.2)	30 (20 to 40)

**Computation Delay**

In the case of IIR filters, the computation delay cannot be determined uniquely (unlike FIR filters). Because IIR filters do not have linear phase characteristics, the delay varies depending on the input frequency.

The group delay characteristics express the relationship between the input signal frequency and the delay. The computation delay is a value obtained by adding 4 sampling clock cycles to the delay time indicated by the group delay characteristics.

The computation delay can be derived from the following equation.

$$\text{Computation delay} = (4 + \text{group delay}) \times \text{sampling period}$$

However, if the sampling frequency exceeds 100 kHz, it is fixed to 100 kHz (10  $\mu$ s). It is also fixed to 100 kHz (10  $\mu$ s) when in envelope mode.

**Characteristics Examples**

- IIR (Butterworth) Low-pass

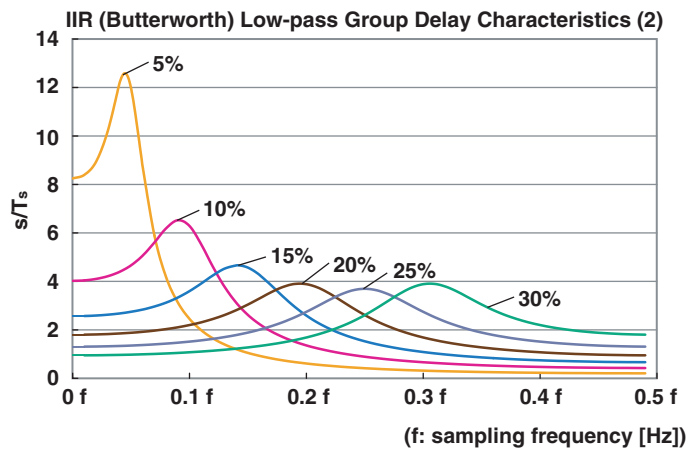
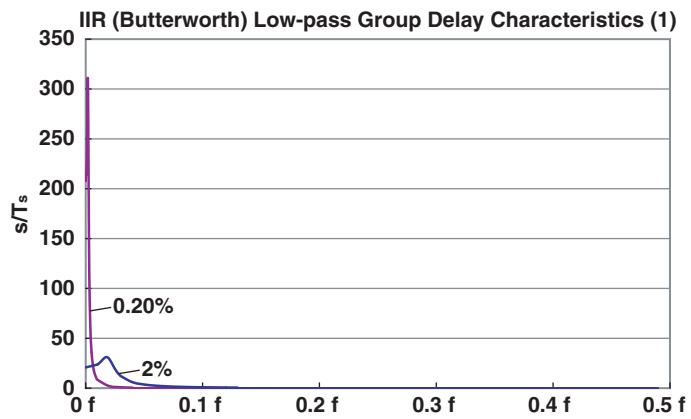
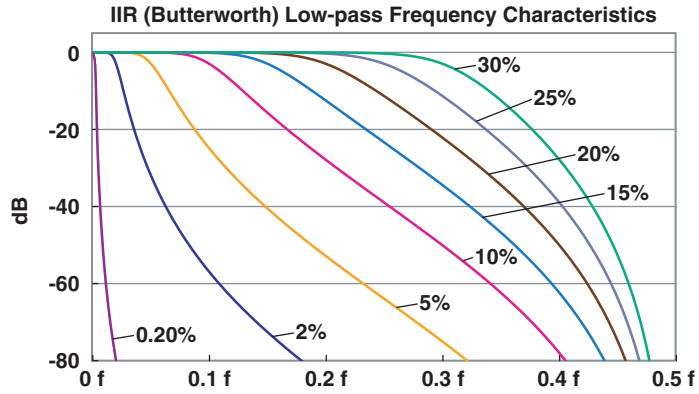

- IIR (Butterworth) High-pass

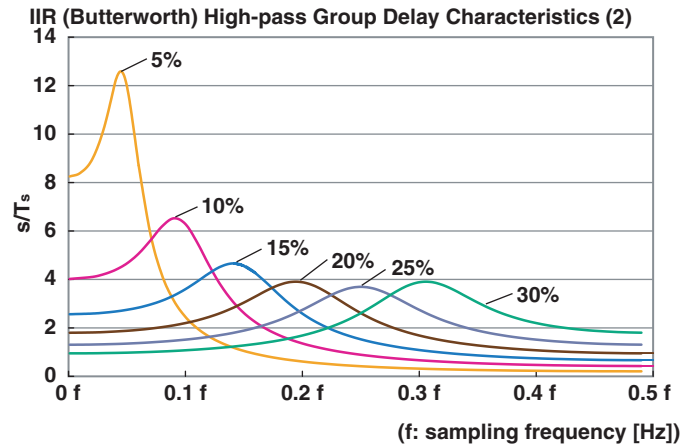
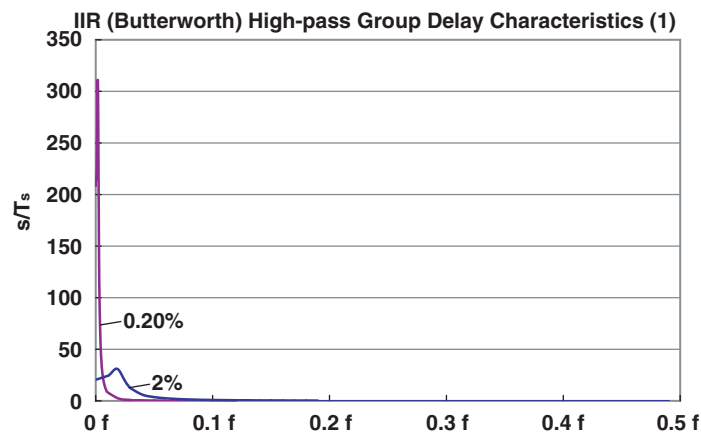
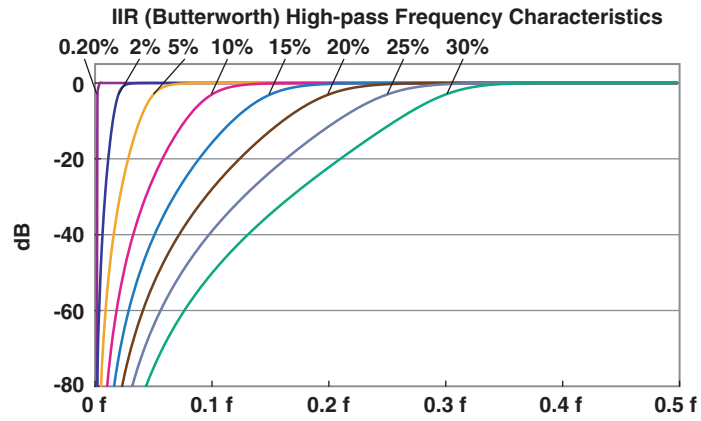

- IIR (Butterworth) Band-pass: Pass-band Width 1%

IIR (Butterworth) Band-pass Frequency Characteristics Pass-band Width 1%

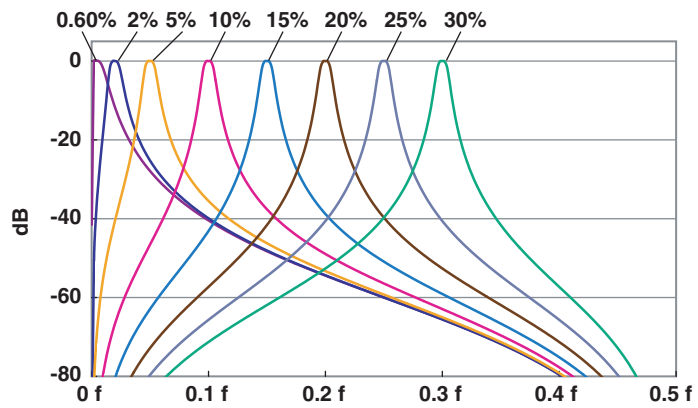

IIR (Butterworth) Band-pass Group Delay Characteristics (1) Pass-band Width 1%

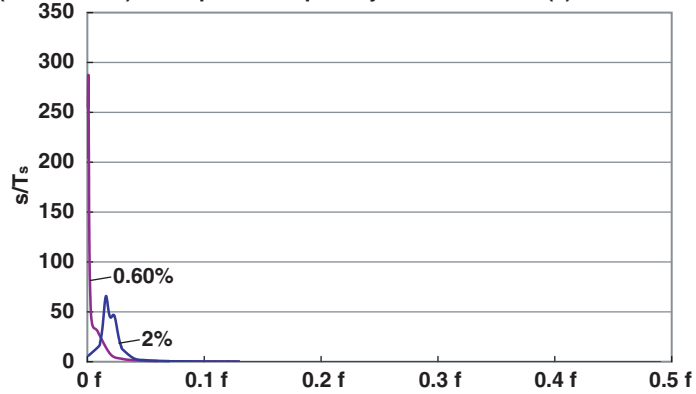

IIR (Butterworth) Band-pass Group Delay Characteristics (2) Pass-band Width 1%

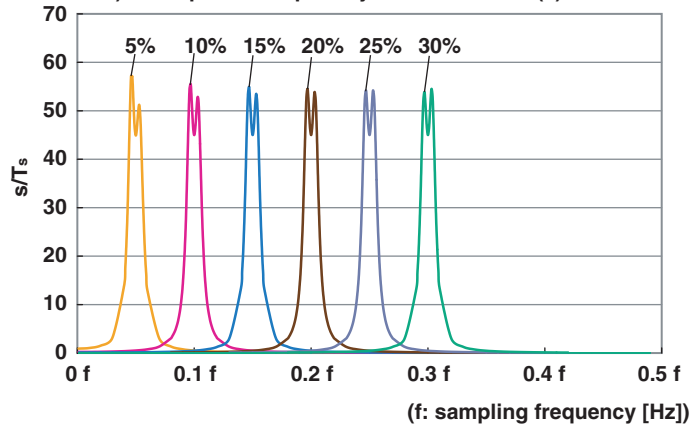

- IIR (Butterworth) Band-pass: Pass-band Width 2%

IIR (Butterworth) Band-pass Frequency Characteristics Pass-band Width 2%

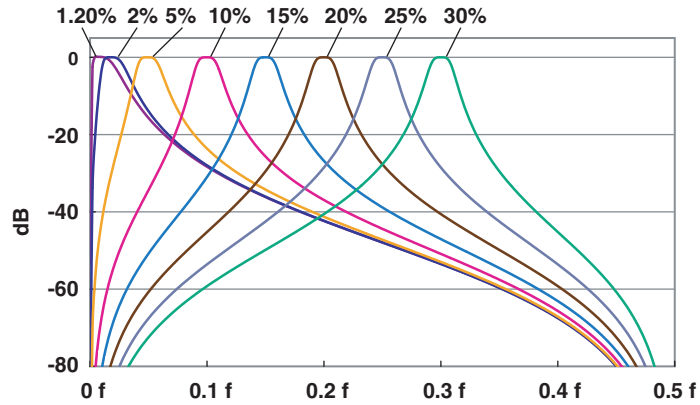

IIR (Butterworth) Band-pass Group Delay Characteristics (1) Pass-band Width 2%

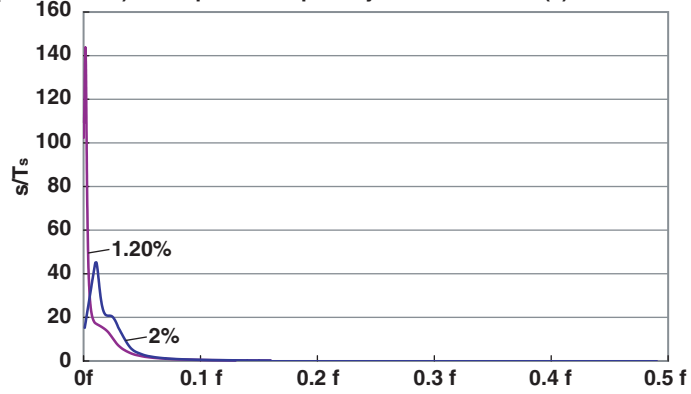

IIR (Butterworth) Band-pass Group Delay Characteristics (2) Pass-band Width 2%

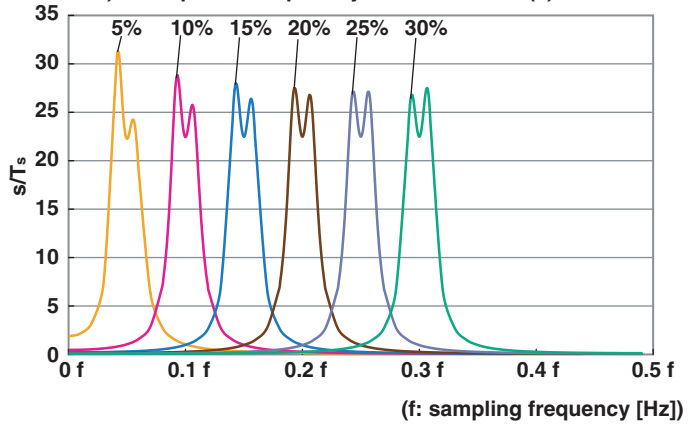

- IIR (Butterworth) Band-pass: Pass-band Width 5%

IIR (Butterworth) Band-pass Frequency Characteristics Pass-band Width 5%

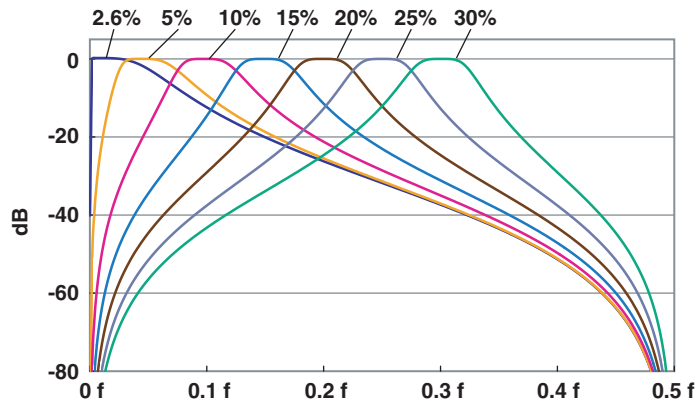

IIR (Butterworth) Band-pass Group Delay Characteristics (1) Pass-band Width 5%

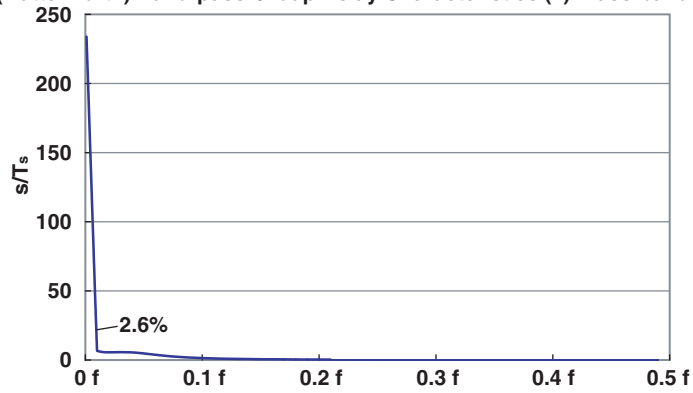

IIR (Butterworth) Band-pass Group Delay Characteristics (2) Pass-band Width 5%

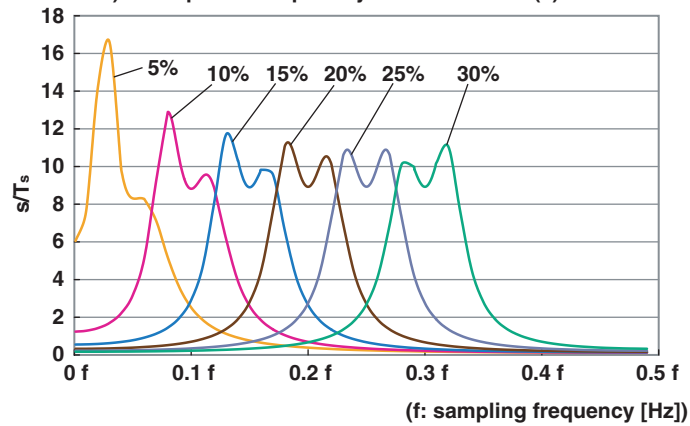



- IIR (Butterworth) Band-pass: Pass-band Width 10%

IIR (Butterworth) Band-pass Frequency Characteristics Pass-band Width 10%

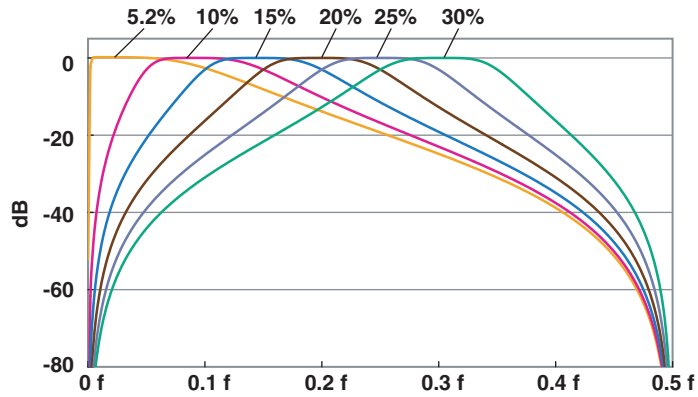

IIR (Butterworth) Band-pass Group Delay Characteristics (1) Pass-band Width 10%

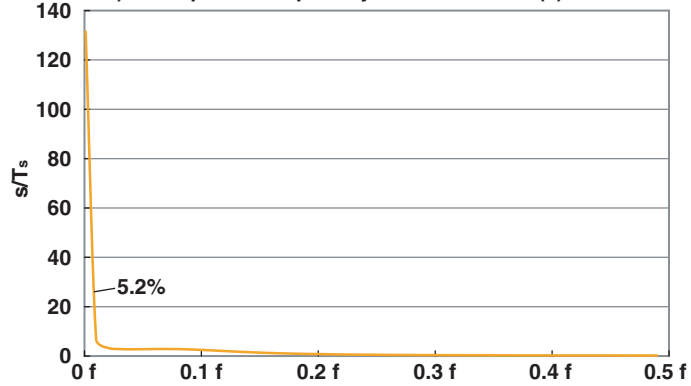

IIR (Butterworth) Band-pass Group Delay Characteristics (2) Pass-band Width 10%

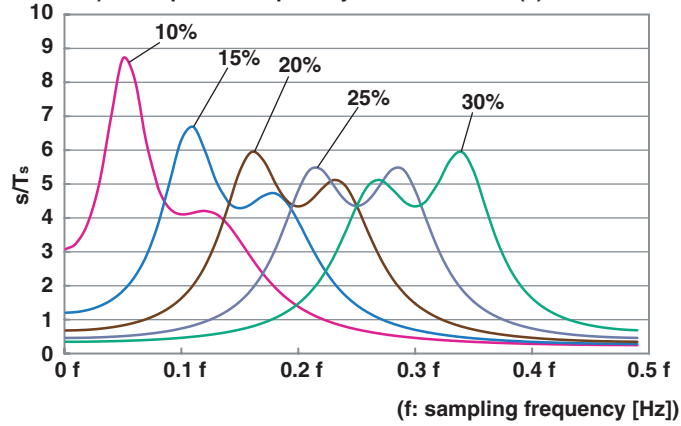

- IIR (Butterworth) Band-pass: Pass-band Width 15%

IIR (Butterworth) Band-pass Frequency Characteristics Pass-band Width 15%

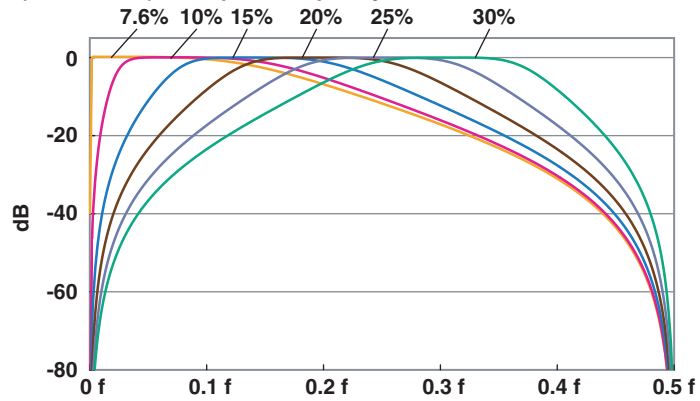

IIR (Butterworth) Band-pass Group Delay Characteristics (1) Pass-band Width 15%

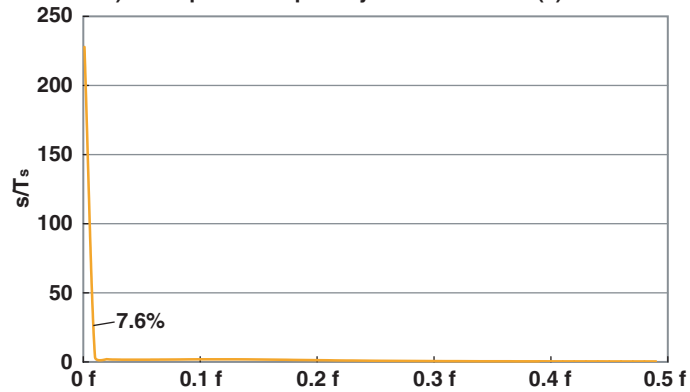

IIR (Butterworth) Band-pass Group Delay Characteristics (2) Pass-band Width 15%

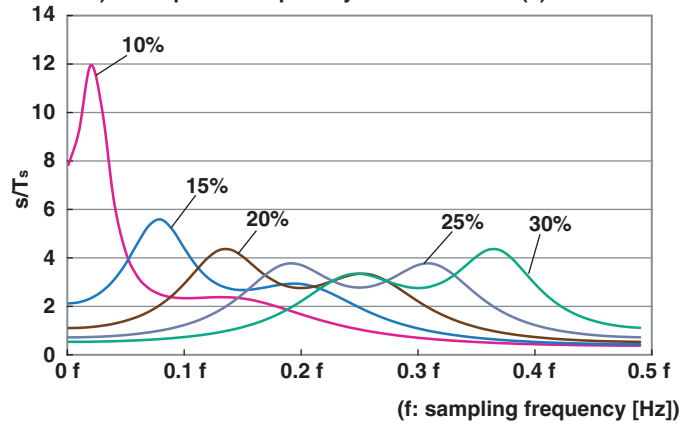

- IIR (Butterworth) Band-pass: Pass-band Width 20%

IIR (Butterworth) Band-pass Frequency Characteristics Pass-band Width 20%

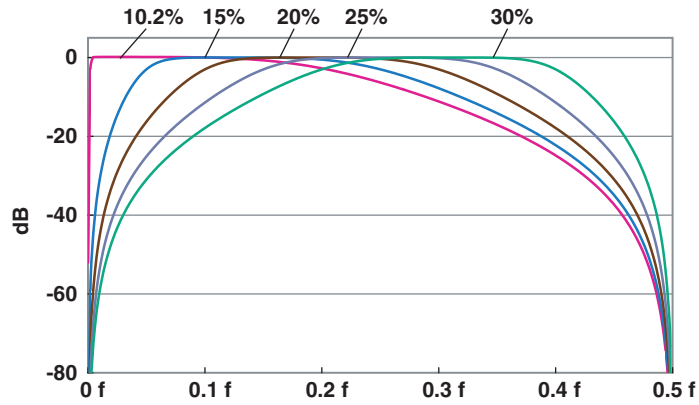

IIR (Butterworth) Band-pass Group Delay Characteristics (1) Pass-band Width 20%

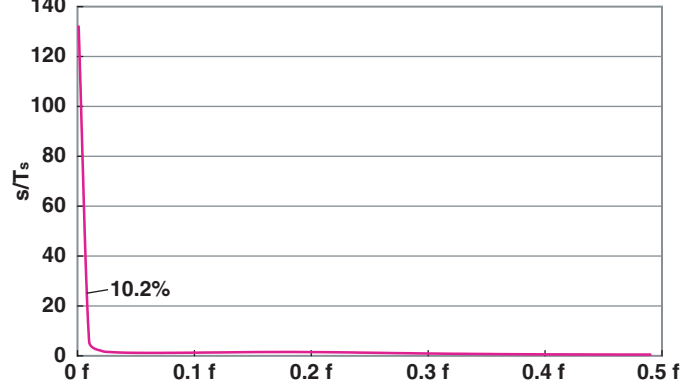

IIR (Butterworth) Band-pass Group Delay Characteristics (2) Pass-band Width 20%

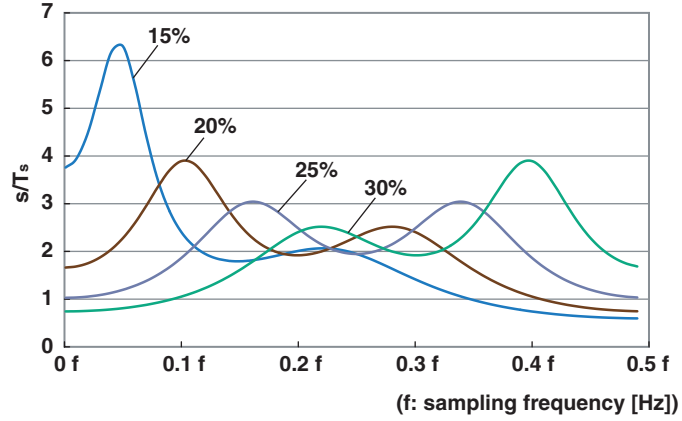

## MEAN (Moving Average) Filter

### Characteristics

- Pass band is flat.
- Has linear phase characteristics and constant group delay.
- The characteristics are of low-pass filters.
- Has comb-shaped bandwidth characteristics.

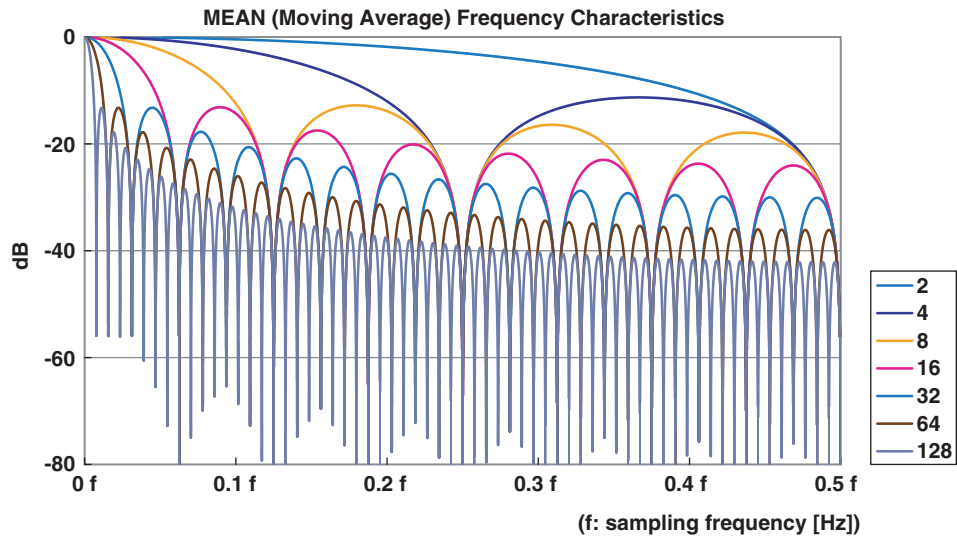

### Computation Delay

The group delay can be derived from the following equation. It is constant and depends on the filter order.

$$\text{Group delay} = (\text{Number of moving average points} - 1)/2$$

Unit:  $s/T_s$  (where  $T_s$  is the sampling frequency [s])

The computation delay can be derived from the following equation.

$$\text{Computation delay} = \{4 + (\text{Number of moving average points} - 1)/2\} \times \text{sampling clock cycle}$$

However, if the sampling frequency exceeds 100 kHz, it is fixed to 100 kHz (10  $\mu$ s).

It is also fixed to 100 kHz (10  $\mu$ s) when in envelope mode.

**Differentiation on DSP Channels**

**Differentiation Characteristics**

In the differentiation on DSP channels, computation is performed using the 5th order Lagrange Interpolation Formula. The 5th order Lagrange Interpolation Formula is as follows. For details, see App-16 page.

$$f_n' = 1/(12T_s)\{f_{n-4}-8f_{n-3}+8f_{n-1}-f_n\}$$

The amplitude characteristics and the ideal differentiation characteristics when the 5th order Lagrange Interpolation Formula is used are indicated below.

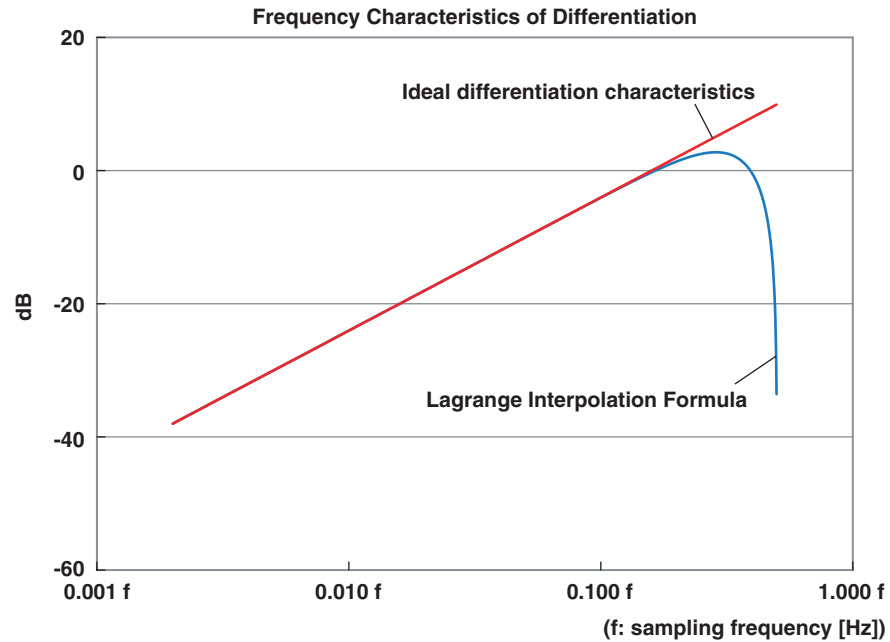

The differentiation characteristics are approximately equal to the ideal differentiation characteristics until the input frequency is 20% of the sampling frequency. At higher frequencies, the high frequency characteristics of the Lagrange Interpolation Formula suppress the high frequency components.

**Computation Delay**

The computation delay is as follows.

$$\text{Computation delay} = (4 + 2^1) \times \text{sampling period}$$

- 1. 2 = delay due to the Lagrange Interpolation

However, if the sampling frequency exceeds 100 kHz, it is fixed to 100 kHz (10 μs). It is also fixed to 100 kHz (10 μs) when in envelope mode.

**Low-Pass Filter Function**

In the differentiation on DSP channels, differentiation can be performed after passing the input signal through a low-pass filter. The low-pass filter used is a SHARP low-pass filter.

For the characteristics of the SHARP low-pass filter, see page app-25.

When the low-pass filter is turned ON, the computation delay increases. The computation time can be derived from the following equation.

$$\{( \text{Order of the SHARP low-pass filter} - 1 ) / 2 \} \times \text{sampling period}$$

For the order corresponding to the specified cutoff frequency, see page app-27.

### Computation Flow and Internal Computation Format of DSP Channels

The computation flow of DSP channels is indicated below. The input and output of DSP channels are 16-bit binary data (if the input is 12 bits, it is converted to 16 bits). Since calculation is performed in 32-bit floating-point decimal format inside the DSP channels, both input and output are converted with 1 LSB weight. Note that the 16-bit binary data of the output is converted with 1 LSB weight that is determined by the Value/DIV setting. Both input and output are displayed after being normalized at 2400 LSB/DIV.

#### Computation Input: Conversion from 16-Bit Binary to Floating-Point

The computation source data is converted to floating-point decimal format with 1 LSB weight at the same time the DSP acquires the data.

$$A(\text{Float}) = A(\text{Binary}) \times (1 \text{ LSB weight})$$

$$B(\text{Float}) = B(\text{Binary}) \times (1 \text{ LSB weight})$$

#### Internal Computation

All calculations are performed using floating-point decimal format inside the DSP. Example:  $C(\text{Float}) = A(\text{Float}) + B(\text{Float})$

#### Calculation of the 1 LSB Weight of the Output

The 1 LSB weight of the output is determined from the DSP range (Value/DIV). Since  $1 \text{ DIV} = 2400 \text{ LSB}$ ,  
 $1 \text{ LSB weight of the output} = [\text{Value}/\text{DIV}]/2400$

#### Computation Output: Conversion from Floating-Point to 16-Bit Binary

The output is converted into 16-bit data according to the following calculation.  
 $C(\text{Binary}) = C(\text{Float}) \div (1 \text{ LSB weight of the output})$

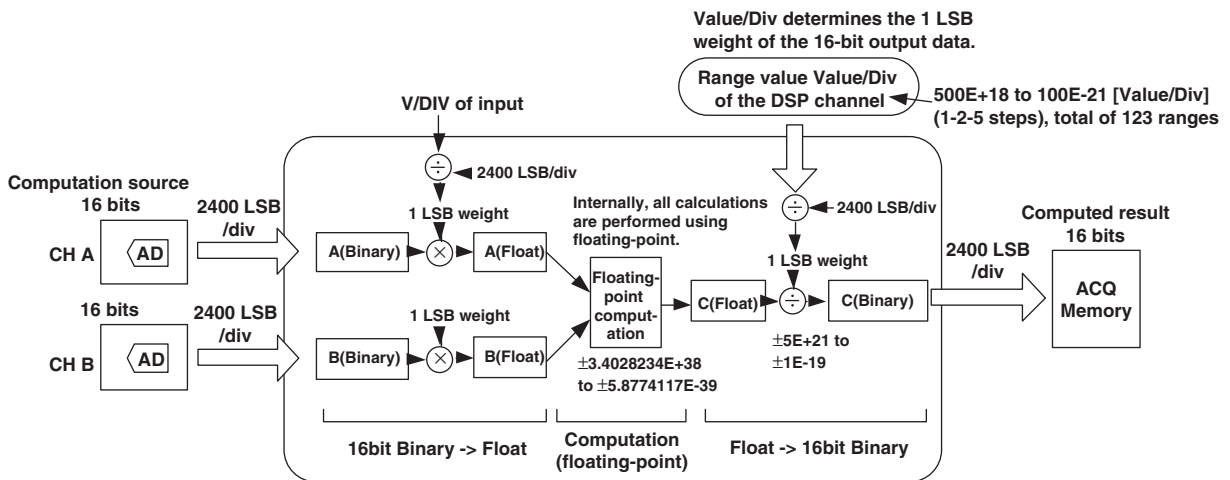

## Appendix 7 List of Defaults

Key	Soft Key	Default Setting
<b>CH1 to 16 (HS10M12 (701250))</b>		
	V/div	50.0 V/div
	Variable	OFF
	Position	0.00 div
	Coupling	DC
	Probe	10:1
	BandWidth	Full
	V Zoom	×1
	Offset	0.0 V
	Linear Scale	OFF
	Invert	OFF
	Label	Channel number
<b>CH1 to 16 (HS1M16 (701251))</b>		
	V/div	50.00 V/div
	Variable	OFF
	Position	0.00 div
	Coupling	DC
	Probe	10:1
	BandWidth	Full
	V Zoom	×1
	Offset	0.00 V
	Linear Scale	OFF
	Invert	OFF
	Label	Channel number
<b>CH1 to 16 (NONISO_10M12(701255))</b>		
	V/div	50.0 V/div
	Variable	OFF
	Position	0.00 div
	Coupling	DC
	Probe	10:1
	BandWidth	Full
	V Zoom	×1
	Offset	0.0 V
	Linear Scale	OFF
	Invert	OFF
	Label	Channel number
<b>CH1 to 16 (HV(with RMS)(701260))</b>		
	V/div	5.000 V/div
	Variable	OFF
	Position	0.00 div
	Coupling	DC
	Probe	1:1
	BandWidth	Full
	V Zoom	×1
	Offset	0.000 V
	Linear Scale	OFF
	Invert	OFF
	Label	Channel number
<b>CH1 to 16 (UNIVERSAL (701261)/UNIVERSAL (AAF) (701262))</b>		
	V/div	5.000 V/div
	Variable	OFF
	Position	0.00 div
	Coupling	DC
	BandWidth	Full
	V Zoom	×1
	Offset	0.000 V
	Linear Scale	OFF
	InVert	OFF
	Label	Channel number

Key	Soft Key	Default Setting
<b>CH1 to 16 (TEMP/HPV (701265))</b>		
	V/div	5.000 V/div
	Variable	OFF
	Position	0.00 div
	Coupling	DC
	BandWidth	Full
	V Zoom	×1
	Offset	0.000 V
	Linear Scale	OFF
	Invert	OFF
	Label	Channel number
<b>CH1 to 16 (STRAIN_NDIS(701270)/STRAIN_DSUB(701271))</b>		
	Range Unit	μSTR
	Range	20000 μSTR
	Upper	20000 μSTR
	Lower	-20000 μSTR
	Excitation	2 V
	Gauge Factor	2.00
	BandWidth	Full
	Linear Scale	OFF
	Label	Channel number
<b>CH1 to 16 (ACCL/VOLT(701275))</b>		
	V/div	50.00 V/div
	Variable	OFF
	Position	0.00 div
	Coupling	DC
	Probe	10:1
	BandWidth	Full
	V Zoom	×1
	Offset	0.00 V
	Linear Scale	OFF
	Invert	OFF
	Label	Channel number
<b>CH1 to 16 (FREQ(701280))</b>		
	V/div	1 kHz/div
	Variable	OFF
	Position	0.00 div
	FV Setup	Frequency
	Input Setup	User
	V Zoom	×1
	Offset	0.000 Hz
	Linear Scale	OFF
	Label	Channel number
<b>Logic A, Logic B</b>		
	Display	OFF
	Position	0 div
	VZoom	×1
	Label	LogicA or LogicB
	Display Bits	ON
	Bit Label	A-1 to A-8, B-1 to B-8
	Bit Mapping	Auto
<b>EVENT</b>		
	Display	OFF
	Position	0 div
	V Zoom	×1
	Label	Event
	Display Bits	ON

Key	Soft Key	Default Setting
<b>START/STOP</b>		
		STOP
<b>TIME/DIV</b>		
		1 ms/div
<b>ACQ</b>		
	Record Length	10 k
	Mode	Normal
	Count	Infinite
	RealTime Out	OFF
	Time Base	Int
<b>SIMPLE/ENHANCED</b>		
	Type	Simple
	Slope	Rising edge
	Source	CH1
	Level	0 V
	Hysteresis	
	Hold Off	0 $\mu$ s
<b>MODE</b>		
		Auto
<b>HISTORY</b>		
	Select Record	0
	Display Mode	One
	Start Record	0
	End Record	Oldest number
	Search Mode	OFF
<b>MEASURE</b>		
	Mode	OFF
	Item Setup:Trace	CH1
	Item Setup:Item	OFF
	Delay Setup:Trace	CH1
	Delay Setup:Mode	OFF
	1cycle Mode	OFF
	Time Range1	-5 div
	Time Range2	5 div
	Trace	CH1
	Dist/Prox Mode	%
	Distal	90%
	Mesial	50%
	Proximal	10%
	High/Low Mode	Auto
<b>CURSOR</b>		
	Type	OFF
<b>DISPLAY</b>		
	Format	Quad
	Interpolation	Line
	Graticule	Grid
	Mapping	Auto
	Tranlucent	OFF
	Extra Window	OFF
	Scale Value	ON
	Trace Label	OFF
	Accumlate	OFF
	Monitor	Both
<b>X-Y</b>		
	Mode	T-Y
	W1:XTrace	
	W1:YTrace	
	W2:XTrace	
	W2:YTrace	
	W3:XTrace	
	W3:YTrace	
	W4:XTrace	
	W4:YTrace	
	Start Point	-5 div
	End Point	5 div

Key	Soft Key	Default Setting
<b>MATH</b>		
	Mode	OFF
	Operation:Math1	OFF
	Operation:Math2	OFF
	Operation:Math3	OFF
	Operation:Math4	OFF
	Operation:Math5	OFF
	Operation:Math6	OFF
	Operation:Math7	OFF
	Operation:Math8	OFF
	Start Point	-5 div
	End Point	5 div
	Threshold:Trace	CH1
	Threshold:Upper	0.0 V
	Threshold:Lower	0.0 V
	Average:Mode	OFF
	Phase Shift	0.000 msec
	Filter:Select	FILT1
	Filter:Type	Gauss
	Filter:Band	Low-Pass
	Filter:CutOff	10.0%
	FFT Point	1 k
	FFT Window	Hanning
	Constant:K1 to K8	1.0000E+00
<b>DSP1 to 6(optional)</b>		
	Display	OFF
	Variable	OFF
	Position	0.0 div
	Setup	C1+C2
	Value/Div	10.00E+00
	V Zoom	$\times 1$
	Label	DSP Channel number
<b>ZOOM</b>		
	Mode	Main
	Format	Main
	Allocation	0 to 3 from 1CH
	Z1 Mag	500 $\mu$ s/div
	Z2 Mag	500 $\mu$ s/div
	Z1 Position	0 div
	Z2 Position	0 div
<b>SEARCH</b>		
	Type	Edge
	Result Window	Z1
	Setup:Source	CH1
	Setup:Level	0 V
	Setup:Polarity	Rising edge
	Setup:Hysteresis	
	Setup:Count	1
	Setup:Start Point	-5 div
<b>DUAL CAPTURE</b>		
	Mode	OFF
	Time/Div	100 $\mu$ s/div
	Capture Num	Current
	Window	OFF
	Window Mag	100 $\mu$ s/div
	Window Pos	0 div
	Event Display	OFF
<b>POSITION/DELAY</b>		
	Position	50%
	Delay	0.0 $\mu$ s



## Appendix 7 List of Defaults

---

Key	Soft Key	Default Setting
<b>GO/NO-GO</b>		
	Mode	OFF
	Logic	AND
	ActCondition	Fail
	Time Range1	-5 div
	Time Range2	5 div
	Sequence	Cont
	ACQ Count	Infinite
	Action:Buzzer	OFF
	Action:Image	OFF
	Action:PRINT	OFF
	Action:Save to File	OFF
	Action:Send Mail	OFF
	Action:Mail Count	100
	Remote	OFF
<b>ACTION</b>		
	Mode	OFF
	Buzzer	OFF
	Image	OFF
	PRINT	OFF
	Save to File	OFF
	Send Mail	OFF
	Mail Count	100
	Sequence	Cont
<b>FILE</b>		
	File Item	Setup
	Auto Naming	Numbering
<b>PRINT MENU</b>		
	Print to	Printer
	Format	Normal
	Time Range1	-5 div
	Time Range2	5 div
	(LongCopy) Mag	500 $\mu$ s/div
<b>SETUP</b>		
	Auto Setup	0 V
	Trace	All
<b>CAL</b>		
	Auto Cal	ON
<b>MISC</b>		
	System Config:Date/Time	2002,01,01
	System Config:Menu Language	Eng
	System Config:Message Language	Eng
	System Config:Click Sound	ON
	SCSI ID:Own ID	6
	SCSI ID:Internal ID	4
	Others:Video Out	ON
	Others:HDD Motor	ON
	Others:Start Mode	OFF
	Others:Action Mode	OFF
	Others:Offset Cancel Mode	OFF
	LCD:Auto Off	OFF
	LCD:Auto Off Time	1 min
	LCD:Brightness	5
	Remote Cntl:Device	GP-IB
	Remote Cntl:Address	1

# Appendix 8 Assignment of Keys on the USB Keyboard

## 104 Keyboard (US)

Key	With the Ctrl Key Held Down on the USB Keyboard		When the Soft Keyboard Is Displayed on the DL750/DL750P		Other	
		When SHIFT is ON on the DL750/DL750P		+Shift on the USB Keyboard		When SHIFT is ON on the DL750/DL750P
A	ACQ menu	Same as left	*1	*1		
B	MATH menu	Same as left	*1	*1		
C	Execute PRINT	PRINT menu	*1	*1		
D	DISPLAY menu	X-Y menu	*1	*1		
E			*1	*1		
F	FILE menu	Same as left	*1	*1		
G			*1	*1		
H	HISTORY menu	Same as left	*1	*1		
I	Execute IMAGE SAVE	IMAGE SAVE menu	*1	*1		
J			*1	*1		
K			*1	*1		
L	ALL CH menu	Same as left	*1	*1		
M	MEASURE menu	GO/NO-GO menu	*1	*1		
N			*1	*1		
O			*1	*1		
P	POSITION menu	DELAY menu	*1	*1		
Q	Execute CLEAR TRACE		*1	*1		
R	Execute RESET	Same as left	*1	*1		
S	SHIFT condition	Clear SHIFT condition	*1	*1		
T	TRIGMODE menu	ACTION menu	*1	*1		
U	CURSOR menu	Same as left	*1	*1		
*2 V	VOICE MEMO menu	Same as left	*1	*1		
W	SIMPLE/ENHANCED menu	Same as left	*1	*1		
*2 X	DUAL CAPTURE menu	Same as left	*1	*1		
Y			*1	*1		
Z	ZOOM menu	SEARCH menu	*1	*1		
1	CH1 menu	DSP1 menu	*1	*1		
2	CH2 menu	DSP2 menu	*1	*1		
3	CH3 menu	DSP3 menu	*1	*1		
4	CH4 menu	DSP4 menu	*1	*1		
5	CH5 menu	DSP5 menu	*1	*1		
6	CH6 menu	DSP6 menu	*1	*1		
7	CH7 menu	Same as left	*1	*1		
8	CH8 menu	Same as left	*1	*1		
9	CH9 menu	Logic A menu	*1	*1		
0	CH10 menu	Logic B menu	*1	*1		
Enter	Return(Enter), Select	Same as left	*1	*1		
Esc	Escape	Same as left	*1	*1		
Back Space			*1	*1		
Tab						
Space Bar			*1	*1		
-			*1	*1		
=			*1	*1		
[			*1	*1		
]			*1	*1		
\	SETUP	CAL menu	*1	*1		
;			*1	*1		
'			*1	*1		
,			*1	*1		
.			*1	*1		
/	MISC menu	Same as left	*1	*1		
Caps Lock			*1	*1		

\*1 Character or symbol similar to the normal PC keyboard is entered.  
(Example) 1 key: 1 is entered if the USB keyboard is not +shift. ! is entered if the USB keyboard is +shift.

\*2 The key assignments below differ from the table above for the DL750P.

V	FEED menu	VOICE MEMO menu	*1	*1		
X	RECORDER menu	DUAL CAPTURE menu	*1	*1		

## Appendix 8 Assignment of Keys on the USB Keyboard

Key	With the Ctrl Key Held Down on the USB Keyboard		When the Soft Keyboard Is Displayed on the DL750/DL750P		Other	
		When SHIFT Is ON on the DL750/DL750P		+Shift on the USB Keyboard		When SHIFT Is ON on the DL750/DL750P
F1	CH11 menu	EVENT menu	Select Soft key1	Same as left	Select Soft key1	Same as left
F2	CH12 menu	Same as left	Select Soft key2	Same as left	Select Soft key2	Same as left
F3	CH13 menu	Same as left	Select Soft key3	Same as left	Select Soft key3	Same as left
F4	CH14 menu	Same as left	Select Soft key4	Same as left	Select Soft key4	Same as left
F5	CH15 menu	Same as left	Select Soft key5	Same as left	Select Soft key5	Same as left
F6	CH16 menu	Same as left	Select Soft key6	Same as left	Select Soft key6	Same as left
F7			Select Soft key7	Same as left	Select Soft key7	Same as left
F8	Escape	Same as left	Escape	Same as left	Escape	Same as left
F9						
F10						
F11			μ	Same as left		
F12	START/STOP	Same as left	Ω	Same as left	START/STOP	Same as left
Print Screen	Execute COPY	PRINT menu				
Scroll Lock	Execute IMAGE SAVE	IMAGE SAVE menu				
Pause	Execute SNAPSHOT	Clear SNAPSHOT				
Insert			Insert condition	Same as left		
Home	Increment V/div	Same as left			Increment V/div	Same as left
Page Up	Increment T/div	Same as left			Increment T/div	Same as left
Delete			*1	*1		
End	Decrement V/div	Same as left			Decrement V/div	Same as left
Page Down	Decrement T/div	Same as left			Decrement T/div	Same as left
→	Cursor to the right	Same as left	Cursor to the right	Same as left	Cursor to the right	Same as left
←	Cursor to the left	Same as left	Cursor to the left	Same as left	Cursor to the left	Same as left
↓	Jog shuttle down	Same as left	Select Soft key6	Same as left	Jog shuttle down	Same as left
↑	Jog shuttle up	Same as left	Select Soft key6	Same as left	Jog shuttle up	Same as left
(Numeric)						
Num Lock						
/			*1	*1		
*	START/STOP	Same as left	*1	*1	START/STOP	Same as left
-			*1	*1		
+			*1	*1		
Enter			*1	*1	Return(Enter), Select	Same as left
1	Decrement V/div	Same as left	*1			Decrement V/div
2	Jog shuttle down	Same as left	*1			Jog shuttle down
3	Decrement T/div	Same as left	*1			Decrement T/div
4	Cursor to the left	Same as left	*1			Cursor to the left
5			*1			
6	Cursor to the right	Same as left	*1			Cursor to the right
7	Increment V/div	Same as left	*1			Increment V/div
8	Jog shuttle up	Same as left	*1			Jog shuttle up
9	Increment T/div	Same as left	*1			Increment T/div
0			*1	Insert condition		
.			*1	Delete		

\*1 Character or symbol similar to the normal PC keyboard is entered.  
 (Example) 1 key: 1 is entered if the USB keyboard is not +shift. ! is entered if the USB keyboard is +shift.

109 Keyboard (Japanese)

Key	With the Ctrl Key Held Down on the USB Keyboard		When the Soft Keyboard Is Displayed on the DL750/DL750P		Other	
		When SHIFT Is ON on the DL750/DL750P		+Shift on the USB Keyboard		When SHIFT Is ON on the DL750/DL750P
A	ACQ menu	Same as left	*1	*1		
B	MATH menu	Same as left	*1	*1		
C	Execute PRINT	PRINT menu	*1	*1		
D	DISPLAY menu	X-Y menu	*1	*1		
E			*1	*1		
F	FILE menu	Same as left	*1	*1		
G			*1	*1		
H	HISTORY menu	Same as left	*1	*1		
I	Execute IMAGE SAVE	IMAGE SAVE menu	*1	*1		
J			*1	*1		
K			*1	*1		
L	ALL CH menu	Same as left	*1	*1		
M	MEASURE menu	GO/NO-GO menu	*1	*1		
N			*1	*1		
O			*1	*1		
P	POSITION menu	DELAY menu	*1	*1		
Q	Execute CLEAR TRACE		*1	*1		
R	Execute RESET	Same as left	*1	*1		
S	SHIFT condition	Clear SHIFT condition	*1	*1		
T	TRIGMODE menu	ACTION menu	*1	*1		
U	CURSOR menu	Same as left	*1	*1		
*2 V	VOICE MEMO menu	Same as left	*1	*1		
W	SIMPLE/ENHANCED menu	Same as left	*1	*1		
*2 X	DUAL CAPTURE menu	Same as left	*1	*1		
Y			*1	*1		
Z	ZOOM menu	SEARCH menu	*1	*1		
1	CH1 menu	DSP1 menu	*1	*1		
2	CH2 menu	DSP2 menu	*1	*1		
3	CH3 menu	DSP3 menu	*1	*1		
4	CH4 menu	DSP4 menu	*1	*1		
5	CH5 menu	DSP5 menu	*1	*1		
6	CH6 menu	DSP6 menu	*1	*1		
7	CH7 menu	Same as left	*1	*1		
8	CH8 menu	Same as left	*1	*1		
9	CH9 menu	Logic A menu	*1	*1		
0	CH10 menu	Logic B menu	*1	*1		
Enter	Return (Enter), Select	Same as left	*1	*1		
Esc	Escape	Same as left	*1	*1		
Back Space			*1	*1		
Tab						
Space Bar			*1	*1		
-			*1	*1		
^			*1	*1		
@			*1	*1		
[			*1	*1		
;			*1	*1		
:			*1	*1		
]			*1	*1		
,			*1	*1		
.			*1	*1		
/	MISC menu	Same as left	*1	*1		
Caps Lock			*1	*1		

\*1 Character or symbol similar to the normal PC keyboard is entered.  
 (Example) 1 key: 1 is entered if the USB keyboard is not +shift. ! is entered if the USB keyboard is +shift.  
 \*2 The key assignments below differ from the table above for the DL750P.

V	FEED menu	VOICE MEMO menu	*1	*1		
X	RECORDER menu	DUAL CAPTURE menu	*1	*1		

## Appendix 8 Assignment of Keys on the USB Keyboard

Key	With the Ctrl Key Held Down on the USB Keyboard		When the Soft Keyboard Is Displayed on the DL750/DL750P		Other	
		When SHIFT Is ON on the DL750/DL750P		+Shift on the USB Keyboard		When SHIFT Is ON on the DL750/DL750P
F1	CH11 menu	EVENT menu	Seletc Soft key1	Same as left	Seletc Soft key1	Same as left
F2	CH12 menu	Same as left	Seletc Soft key2	Same as left	Seletc Soft key2	Same as left
F3	CH13 menu	Same as left	Seletc Soft key3	Same as left	Seletc Soft key3	Same as left
F4	CH14 menu	Same as left	Seletc Soft key4	Same as left	Seletc Soft key4	Same as left
F5	CH15 menu	Same as left	Seletc Soft key5	Same as left	Seletc Soft key5	Same as left
F6	CH16 menu	Same as left	Seletc Soft key6	Same as left	Seletc Soft key6	Same as left
F7			Seletc Soft key7	Same as left	Seletc Soft key7	Same as left
F8	Escape	Same as left	Escape	Same as left	Escape	Same as left
F9						
F10						
F11			μ	Same as left		
F12	START/STOP	Same as left	Ω	Same as left	START/STOP	Same as left
Print Screen	Execute COPY	PRINT menu				
Scroll Lock	Execute IMAGE SAVE	IMAGE SAVE menu				
Pause	Execute SNAPSHOT	Clear SNAPSHOT				
Insert			Insert condition	Same as left		
Home	Increment V/div	Same as left			Increment V/div	Same as left
Page Up	Increment T/div	Same as left			Increment T/div	Same as left
Delete			*1	*1		
End	Decrement V/div	Same as left			Decrement V/div	Same as left
Page Down	Decrement T/div	Same as left			Decrement T/div	Same as left
→	Cursor to the right	Same as left	Cursor to the right	Same as left	Cursor to the right	Same as left
←	Cursor to the left	Same as left	Cursor to the left	Same as left	Cursor to the left	Same as left
↓	Jog shuttle down	Same as left	Seletc Soft key6	Same as left	Jog shuttle down	Same as left
↑	Jog shuttle up	Same as left	Seletc Soft key6	Same as left	Jog shuttle up	Same as left
\	SETUP menu	CAL menu	*1	*1		
\			*1	*1		
(Numeric)						
Num Lock						
/			*1	*1		
*	START/STOP	Same as left	*1	*1	START/STOP	Same as left
-			*1	*1		
+			*1	*1		
Enter			*1	*1	Return(Enter), Select	Same as left
1	Decrement V/div	Same as left	*1			Decrement V/div
2	Jog shuttle down	Same as left	*1			Jog shuttle down
3	Decrement T/div	Same as left	*1			Decrement T/div
4	Cursor to the left	Same as left	*1			Cursor to the left
5			*1			
6	Cursor to the right	Same as left	*1			Cursor to the right
7	Increment V/div	Same as left	*1			Increment V/div
8	Jog shuttle up	Same as left	*1			Jog shuttle up
9	Increment T/div	Same as left	*1			Increment T/div
0			*1	Insert condition		
.			*1	Delete		

\*1 Character or symbol similar to the normal PC keyboard is entered.  
 (Example) 1 key: 1 is entered if the USB keyboard is not +shift. ! is entered if the USB keyboard is +shift.

---

## Appendix 9 Waveform Acquisition Operation When the Power Supply Recovers after a Power Failure

The waveform acquisition operation when the power supply recovers after a power failure varies depending on the following two conditions.

- **Start Mode (Power On)**  
Whether to start waveform acquisition at power on.
- **Acquisition memory backup switch**  
Whether to back up the acquisition memory

- **When Start Mode (Power On) Is OFF**

- **When the Backup Switch Is OFF**

- The history memory is cleared.

- Waveform acquisition does not start regardless of whether measurement was in progress before the power failure.

- **When the Backup Switch Is ON**

- The history memory is held.

- If waveform acquisition was in progress before the power failure, the waveform acquisition is resumed.<sup>1</sup>

- Waveform acquisition does not start if measurement was stopped before the power failure.

### Note

---

The behavior when the backup switch is ON but the batteries go flat while backing up the data is as follows:

- The history memory is cleared.
  - Waveform acquisition does not start regardless of whether measurement was in progress before the power failure.
- 

- **When Start Mode (Power On) Is ON**

- **When the Backup Switch Is OFF**

- The history memory is cleared.

- Waveform acquisition starts regardless of whether measurement was in progress before the power failure.

- **When the Backup Switch Is ON**

- The history memory is held.

- If waveform acquisition was in progress before the power failure, the waveform acquisition is resumed.<sup>1</sup> Waveform acquisition starts if measurement was stopped before the power failure.

### Note

---

The behavior when the backup switch is ON but the batteries go flat while backing up the data is as follows:

- The history memory is cleared.
  - Waveform acquisition starts regardless of whether measurement was in progress before the power failure.
- 

1. • If the acquisition mode is set to average or if realtime recording is in progress, waveform acquisition is restarted. If a power failure occurs during realtime recording, the realtime recording file becomes an invalid file (this file cannot be loaded). Be sure that the power supply is not interrupted during realtime recording.
- Acquisition of waveforms continues during roll mode display. If the display is not in roll mode, pre-trigger data is acquired from the beginning for pre-triggered waveforms. The data of post-trigger waveform up to the power failure is considered valid, and the acquisition of waveforms continues from that point.

# Appendix 10 Basic Defining Equation of Strain

## Definition of Strain

$$\Delta L/L = \epsilon \quad (1)$$

$\epsilon$ : Strain  
 $L$ : Initial length of the material  
 $\Delta L$ : Amount of change due to external strain

## Definition of the Gauge Factor

Gauge factor (K) refers to the ratio between the mechanical strain and the change in the resistance of the strain gauge resistor.

$$\epsilon = \frac{\Delta L}{L} = \frac{\Delta R/R}{K} \quad (2)$$

$$(\Delta R/R) = K \times \epsilon \quad (3)$$

$R$ : Gauge resistance  
 $\Delta R$ : Amount of change in resistance when a strain is received

Normally,  $K=2.0$ . However, the value varies depending on the strain gauge material.

## General Equation of the Measured Voltage (V) and Strain ( $\epsilon$ ) of the Wheatstone Bridge (1 Gauge Method)

If we assume  $V$  to be the voltage measured on the bridge and  $E$  to be the voltage applied to the bridge,

$$V = (1/4) \times E \times (\Delta R/R) \quad (4)$$

From equation (3),

$$(\Delta R/R) = K \times \epsilon$$

$$\text{Thus, } V = (1/4) \times E \times K \times \epsilon \quad (5)$$

- **When Determining the Strain ( $\epsilon$ ) from the Measured Voltage (V) (Strain Gauge (1 Gauge Method))**

If we derive  $\epsilon$  from equation (5)

$$\epsilon = (4/K) \times (V/E) \quad (6)$$

- **When Determining the Measured Value of the Strain Gauge Sensor (e) from the Voltage Measured on the Bridge (V) (Strain Gauge Sensor)**

Assuming  $e$  to be the measured value (measured value of the strain gauge sensor:  $mV/V$  unit) and substituting  $\epsilon = e$  in equation (6),

$$\epsilon = (4/K) \times (V/E) \quad (7)$$

In the case of a strain gauge sensor, set the Gauge Factor (K) to 2 on the DL750/DL750P. If you change the value of K, conversion is made using the above equation.

# Appendix 11 Shunt Calibration of the Strain Module

Shunt calibration is used to correct the gain of strain measurements by inserting a known resistance (shunt calibration resistance (shunt resistance)) in parallel with the strain gauge. The Strain Module (701271)(STRAIN\_DSUB) supports shunt calibration and contains a built-in relay circuit for shunt calibration.

To execute shunt calibration, a bridge head that supports shunt calibration (701957/701958) is needed.

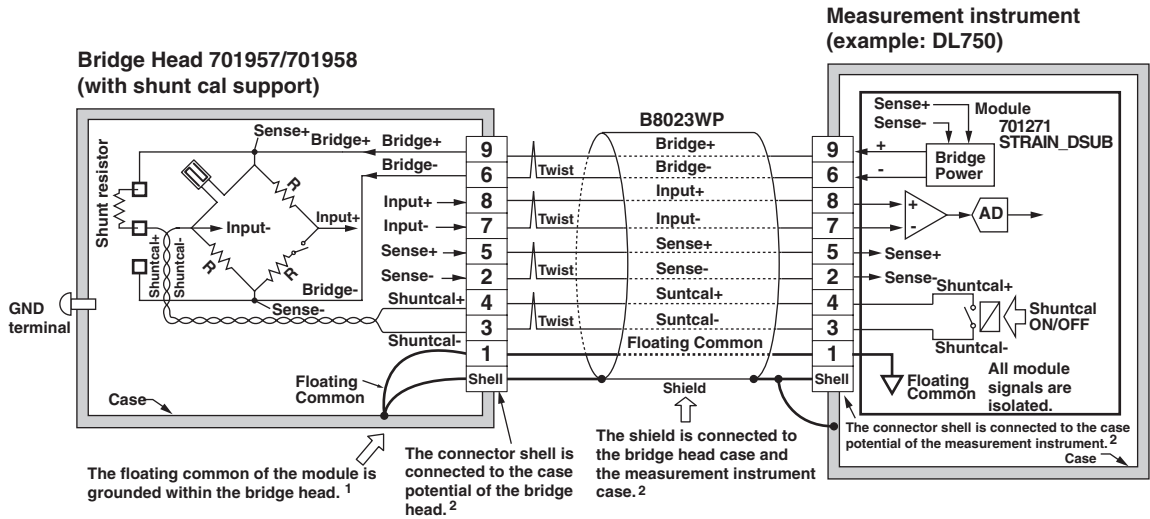

1. The GND (floating common) of the module is connected to the case potential inside the bridge box.
2. The bridge head case, the cable shield, and the measurement instrument case are connected as measures against noise.

• When correcting the gain on the negative side (normal)

Shunt calibration relay circuit (Built into the strain module. Turns ON/OFF automatically when shunt calibration is executed.)

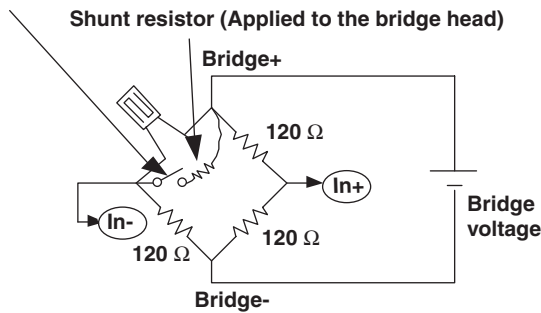

• When correcting the gain on the positive side

Shunt calibration relay circuit (Built into the strain module. Turns ON/OFF automatically when shunt calibration is executed.)

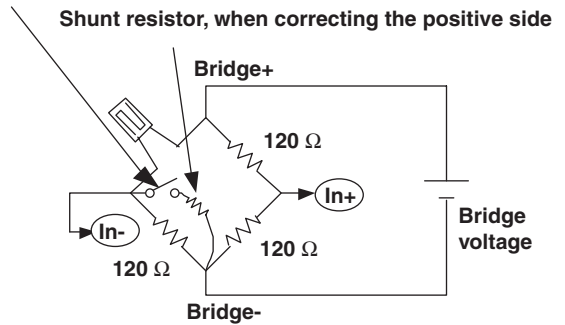



**Shunt Calibration Procedure**

1. Calculate the strain value ( $\mu\text{STR}$ ) corresponding to the shunt resistor to be used. For the calculation procedure, see “Calculating the Shunt Resistance” in the next section.
2. Execute balancing without applying a load to the strain gauge and correct the zero point.
3. Execute shunt calibration and correct the gain.

Shunt calibration is executed using DL750/DL750P channel menu > Linear Scale > Mode. Usually, the negative gain is corrected. However, if you are correcting the positive gain, change the position of the shunt resistor as shown in the upper right figure.

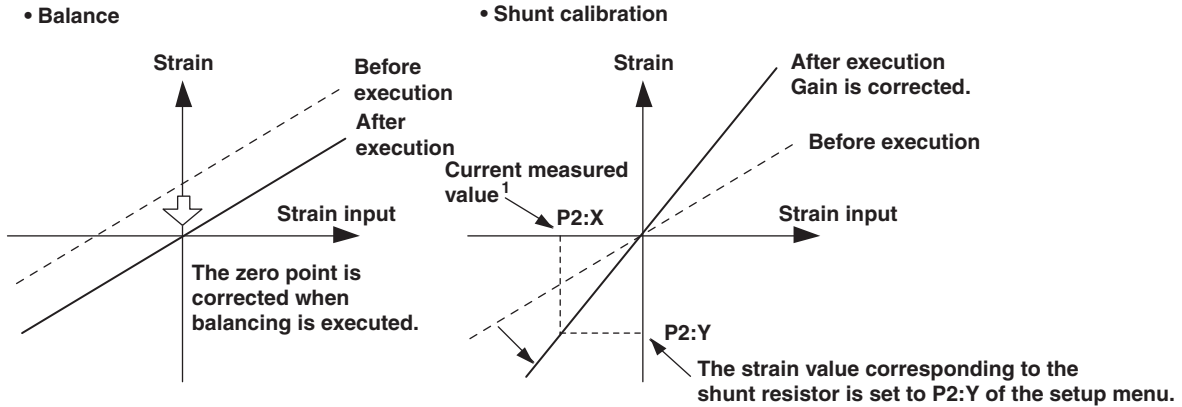

1. Automatically obtained when shunt calibration is executed.

**Execution Menu of Shunt Calibration**

The execution menu of shunt calibration is set using channel menu > Linear Scale > Mode. In normal shunt calibration, only P2:Y is set. In addition to the normal shunt calibration (when the shunt calibration relay circuit is ON), the DL750/DL750P allows the setting of a zero point when the relay circuit is OFF. This function is useful when the strain value is not 0 after the execution of balancing.

**Items in the Execution Menu**

- (1) P1:X: If (Shunt Cal) Exec is executed, the input value when the relay circuit is OFF is applied.
- (2) P1:Y: Sets the value (usually 0) when the relay circuit is OFF.
- (3) P2:X: If (Shunt Cal) Exec is executed when the relay circuit is ON, the input value when the relay circuit is ON is applied.
- (4) P2:Y: Set the strain value corresponding to the shunt resistance when the relay circuit is ON.

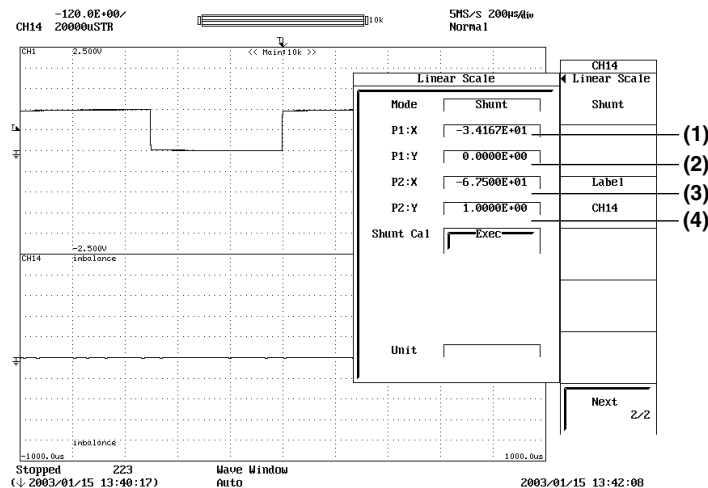

**Note**

- When executing shunt calibration, select an appropriate range so that the measured values do not exceed the range when the shunt calibration relay circuit is ON. The DL750/DL750P attempts shunt calibration within the current specified range.
- If shunt calibration fails (the measured value exceeds the range, for example), an error message is displayed. In such case, change the range and execute shunt calibration again.

**Taking Measures against Noise**

Because measurements are made at the  $\mu\text{V}$  level, the strain gauge is extremely susceptible to noise. If the execution of balancing or shunt calibration fails, it may be due to the effect of noise. Check the following points.

- Because the strain gauge is attached away from the bridge head, it is recommended that twisted wire be used for extension.
- Use a bridge head with high noise resistance. It is recommended that YOKOGAWA bridge head (701957/701958) with high noise resistance be used.

**Calculation of the Shunt Resistance**

To execute shunt calibration, the shunt resistance ( $R_s$ ) and the expected strain ( $\epsilon$ ) need to be calculated in advance. Use  $\epsilon$  as given in the equation below (normally a negative value). With the DL750/DL750P, enter the value into “P2-Y” under the shunt calibration execution menu. However, when using the general method given for shunt calibration (the easy method), an error of 1 to 2% can be introduced as the strain value ( $\epsilon$ ) increases. Therefore, calculate using the detailed method whenever possible. Also, you must select a setting range value that will not result in an overrange.

**Equation for  $R_s$  and  $\epsilon$  When Executing Shunt Calibration**

• **General Equation**

$\Delta R/R = K \times \epsilon$  (1): Basic Equation of Strain

$\Delta R = R - R/R_s$  (2): Equation of the change in resistance when the shunt resistance is ON

In this manual, the parallel equation of resistors are expressed as follows:

$$R/R_s = \frac{1}{\frac{1}{R} + \frac{1}{R_s}} = \frac{R \times R_s}{R + R_s}$$

If  $\Delta R$  is cancelled out from (1) and (2),

**$R_s = R \times (1 - K \times \epsilon) / (K \times \epsilon)$**  (Equation A): General equation used to calculate the shunt resistance (includes error)

- $\epsilon$ : Strain (strain you wish to generate when the shunt resistance is turned ON)
- K: Gauge factor
- R: Bridge resistance
- $\Delta R$ : Resistance change
- $R_s$ : Shunt resistance (shunt resistance you wish to derive)

**Appendix 11 Shunt Calibration of the Strain Module**

• **Detailed Equation**

$$V_0 = E \times (R_1 \times R_3 - R_2 \times R_4) / \{(R_1 + R_2) \times (R_3 + R_4)\}$$

(1): Basic Equation of Wheatstone Bridge

When shunt calibration is ON,

$$V_0 = E \times (R_1 \times R_3 - R' \times R_4) / \{(R_1 + R') \times (R_3 + R_4)\}$$

(2): Equation when turned ON

$$R' = R_2 // R_s$$

(3): Equation of combined resistance R'

$$R_1 = R_2 = R_3 = R_4 = R$$

(4): Since  $R_1$  to  $R_4$  are equal, we represent them as R

Also, from the basic equation of strain,

$$V_0/E = K \times \epsilon / 4$$

(5): Basic equation of strain

If  $V_0/E$  and  $R_1$  to  $R_4$  are cancelled out from (2), (3), (4), and (5),

$$R_s = R \times (1 - K \times \epsilon / 2) / (K \times \epsilon)$$

(Equation B): Detailed equation used to calculate the shunt resistance (no error)

- E: Bridge voltage
- $V_0$ : Bridge output voltage
- $R_1$  to  $R_4$ : Bridge resistance (except,  $R_1 = R_2 = R_3 = R_4$ )
- $R_s$ : Shunt resistance (shunt resistance you wish to derive)
- $R'$ : Combined resistance when the relay is turned ON ( $R' = R // R_s$ )

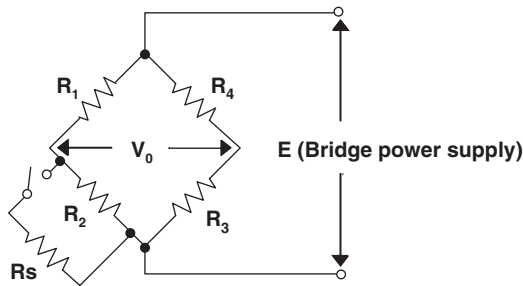

**Calculation Example**

- **When Determining the Corresponding Shunt Resistance (Rs) from the Strain (ε)**

Given a gauge factor (K) of 2,

Detailed equation  $R_s = R \times (1 - \epsilon) / (2 \times \epsilon)$  (6)  
(equation B)

General equation  $R_s = R \times (1 - 2 \times \epsilon) / (2 \times \epsilon)$  (7): Error of 1 to 2% present  
(equation A)

Desired Strain ε (μSTR)	Derived by the Detailed Equation (6) Rs Value (Ω)		Rs value (Ω) Derived by the General Equation (7)	
	R=120 Ω	R=350 Ω	R=120 Ω	R=350 Ω
1,000	59,940	174,825	59,880	174,650
2,000	29,940	87,325	29,880	87,150
5,000	11,940	34,825	11,880	34,650
10,000	5,940	17,325	5,880	17,150

- **When Determining the Corresponding Strain (ε) from the Shunt Resistance (Rs)**

If we derive e from equation (6) and (7),

Detailed equation  $\epsilon = 1 / (1 + 2 \times R_s / R)$  (8)  
(equation B)

General equation  $\epsilon = 1 / \{2 \times (1 + R_s / R)\}$  (9): Error of 1 to 2% present  
(equation A)

**When the Bridge Resistance R is 120 Ω**

RS Value (Ω)	Strain ε (μSTR) Derived by the Detailed Equation (8)	Strain ε (μSTR) Derived by the General Equation (9)
60,000	999	998
30,000	1,996	1,992
12,000	4,975	4,950
6,000	9,901	9,804

**When the Bridge Resistance R is 350 W**

RS Value (Ω)	Strain ε (μSTR) Derived by the Detailed Equation (8)	Strain ε (μSTR) Derived by the General Equation (9)
180,000	971	970
90,000	1,941	1,937
36,000	4,838	4,814
18,000	9,629	9,537

# Appendix 12 Measurement Principles (Measurement Method and Update Rate) of the Frequency Module

## Measurement Principles of the Frequency Module

The measurement principles of period, frequency, pulse width, and duty cycle on the frequency module (701280 (FREQ)) are described below.

### Period and Frequency Measurement

The frequency module updates the waveform at a rate of 25 kHz (40- $\mu$ s interval). The measurement method differs for frequencies above 25 kHz and below 25 kHz.

- When the input signal is less than or equal to 25 kHz, measurement is made as described in (1).
- When the input signal is greater than or equal to 25 kHz, measurement is made as described in (2).
- The sequence of processing described below is performed simultaneously through pipeline processing. Thus, the period (t) and frequency (f) are updated every 40  $\mu$ s.

(1) When the input signal is less than or equal to 25 kHz

Measures the time of occurrence of the pulse edge (T1) in measurement interval A. Measures the time of occurrence of the pulse edge (T2) in measurement interval B. Calculates the period (t) = T2 – T1 in measurement interval C.

The frequency (f) is calculated as 1/period (t).

When the period of the input pulse spans over multiple measurement intervals, computation is performed at the measurement interval following the interval in which the edge is detected.

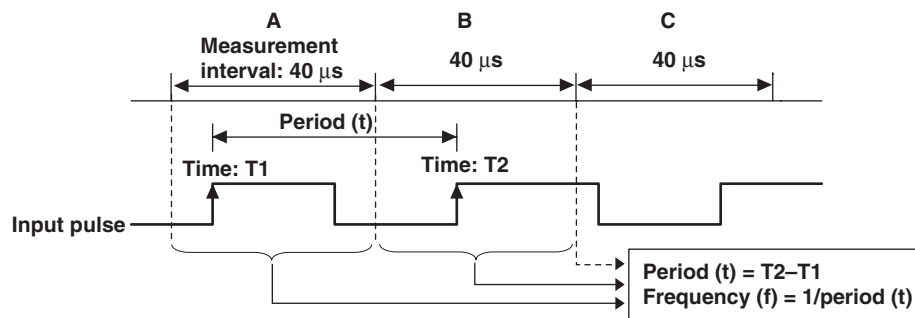

(2) When the input signal is greater than or equal to 25 kHz

Measures the time of occurrence of the last pulse edge (Te1) in measurement interval A. Measures the time of occurrence of the last pulse edge (Te2) in measurement interval B. Measures the number of pulses between the last pulse edge in measurement interval A and the last pulse edge of measurement interval B.

Calculates the period (t) = (Te2 – Te1)/the number of pulses in measurement interval C. Period (t) is the average value of multiple pulses.

The frequency (f) is calculated as 1/period (t).

If the input pulse period is short, the DL750/DL750P automatically takes the average of multiple pulses and calculates the period and frequency. Therefore, the resolution does not degrade even when the input pulse period is short, and highly accurate measurement is possible.

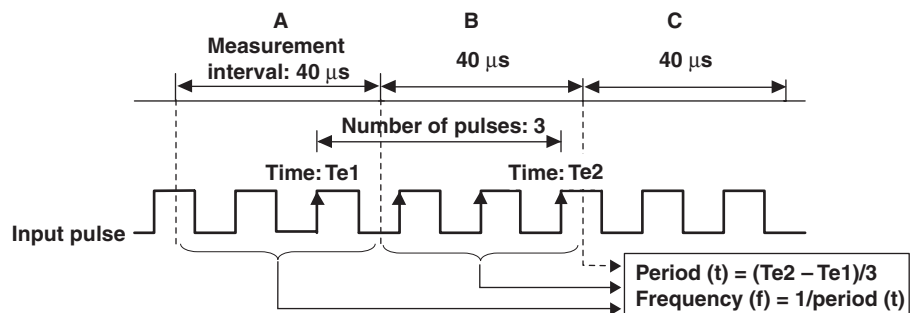

**Pulse Width and Duty Cycle Measurement**

- When the input signal is less than or equal to 25 kHz, measurement is made as described in (1).
- When the input signal is greater than or equal to 25 kHz, measurement is made from the last waveform in the measurement interval as described in (2).
- The sequence of processing described below is performed simultaneously through pipeline processing. Thus, the period (t) and frequency (f) are updated every 40 μs.

(1) When the input signal is less than or equal to 25 kHz

Measures the times of occurrences of pulse edges (T1, T2, and T3) in measurement intervals A and B.

In measurement interval C:

For pulse width: Calculates pulse width = T2 – T1.

For duty cycle: Calculates duty cycle = (T2 – T1)/(T3 – T1).

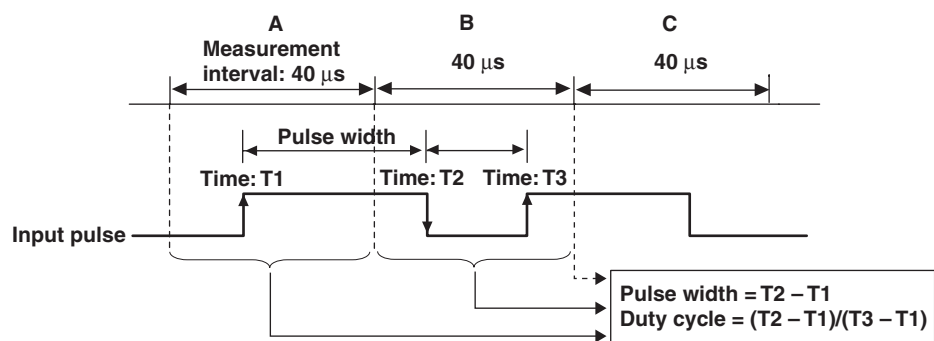

(2) When the input signal is greater than or equal to 25 kHz

Measures the times of occurrences of pulse edges (T1, T2, and T3) in measurement interval A.

In measurement interval B:

For pulse width: Calculates pulse width = T2 – T1.

For duty cycle: Calculates duty cycle = (T2 – T1)/(T3 – T1).

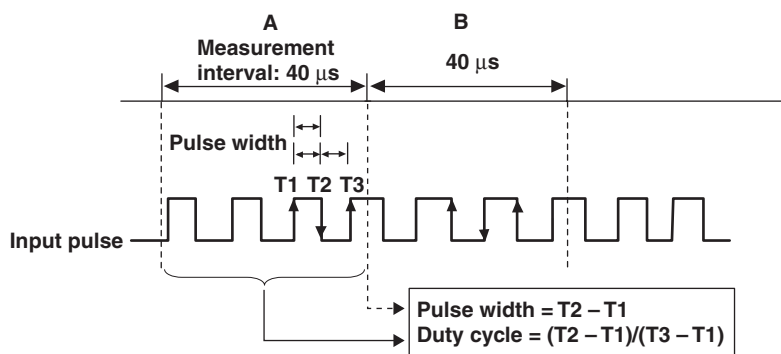

### Computation Format (Resolution) of the Frequency Module

The computation flow on the frequency module is indicated below.

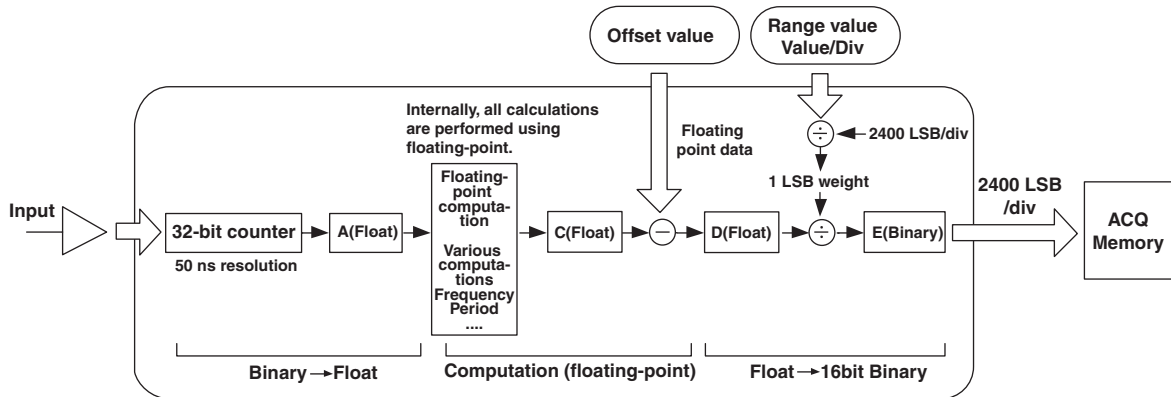

The frequency module measures the period of the input signal using a 32-bit counter of 50-ns resolution. Therefore, the minimum resolution of the counter values is 50 ns. Various computations are performed in floating point format. The data that is output from the frequency module and written to the acquisition memory (ACQ Memory) is 16-bit binary data. The data is converted using a weight of 1 LSB that is determined by Value/div. The data is normalized to 2400 LSB/div when displayed on the screen.

#### Input: Conversion from the 32-bit Counter Value to Floating Point

Converts the count value obtained using the 32-bit counter with 50-ns resolution to floating point format, and determines period A using the following equation.

$$\text{Period: } A \text{ (float)} = (\text{count value}) \times 50 \text{ ns}$$

#### Computation

Various computations are performed in floating point format based on the settings.

Example)      Frequency:  $C \text{ (float)} = 1/A \text{ (float)}$

#### Calculation of the 1 LSB Weight of the Output

The 1 LSB weight of the output is determined from the range (Value/div).

Since 1 div = 2400 LSB,

$$1 \text{ LSB weight of the output} = (\text{Value/div})/2400$$

#### Computation Output: Conversion from Floating Point to 16-bit Binary (When Offset Is 0)

When the offset value is 0, offset calculation is not performed, and  $C \text{ (float)} = D \text{ (float)}$ .

The data is converted into 16-bit binary data and written to the acquisition memory (ACQ Memory).

$$16\text{-bit binary data: } E \text{ (binary)} = D \text{ (float)} / (1 \text{ LSB weight of the output})$$

#### Offset Computation

When the offset value is not 0, the offset value is computed in floating point format using the following equation and converted to 16-bit binary data.

$$D \text{ (float)} = C \text{ (float)} - \text{offset value (float)}$$

In offset computation, if the computed result C is equal to the offset value, the output is 0.

If the computed result C (float) is less than the offset value, E (binary) is negative.

### Filter Characteristics (Time Delay) of the Smoothing Filter

The smoothing filter is a moving average filter in which computation is performed in realtime. The computation interval of moving average is 40  $\mu$ s (25 kHz). It is constant independent of the sampling rate of the DL750/DL750P.

The moving average order (the number of points of moving average) is specified in time. The maximum value is 25000 order (when set to 1000 ms).

The characteristics of the smoothing filter are as follows:

- The filter is a low-pass filter.
- Pass band is flat.
- Has linear phase characteristics and constant group delay by filter order.

The group delay is derived using the following equation.

$$\text{Group delay} = (\text{the number of points of moving average} - 1) \times 40 \mu\text{s}/2$$

- Has comb-shaped bandwidth characteristics. (See page app-43.)

The figure below shows the result when the smoothing filter is applied to a waveform that changes in steps. The switching filter setup time follows the step change.

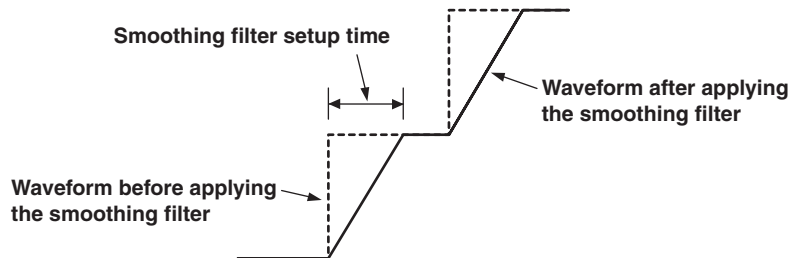



## Appendix 13 List of Preset Settings of the Frequency Module

### Logic 5V

Setup Item	Setting
V Range	±10 V
Coupling	DC
Probe	Yes <sup>1</sup>
Bandwidth	Yes <sup>2</sup>
Threshold	2.5 V
Hys	Yes <sup>3</sup>
Slope	Yes <sup>4</sup>
Chatter Elimination	Yes <sup>5</sup>
Pull Up	No

### Logic 3V

Setup Item	Setting
V Range	±5 V (Probe = 1:1) ±10 V (Probe = 10:1)
Coupling	DC
Probe	Yes <sup>1</sup>
Bandwidth	Yes <sup>2</sup>
Threshold	1.5 V
Hys	Yes <sup>3</sup>
Slope	Yes <sup>4</sup>
Chatter Elimination	Yes <sup>5</sup>
Pull Up	No

### Logic 12V

Setup Item	Setting
V Range	±20 V
Coupling	DC
Probe	Yes <sup>1</sup>
Bandwidth	Yes <sup>2</sup>
Threshold	6 V
Hys	Yes <sup>3</sup>
Slope	Yes <sup>4</sup>
Chatter Elimination	Yes <sup>5</sup>
Pull Up	No

### Logic 24V

Setup Item	Setting
V Range	±50 V
Coupling	DC
Probe	Yes <sup>1</sup>
Bandwidth	Yes <sup>2</sup>
Threshold	12 V
Hys	Yes <sup>3</sup>
Slope	Yes <sup>4</sup>
Chatter Elimination	Yes <sup>5</sup>
Pull Up	No

### Pull-up 5V

Setup Item	Setting
V Range	±10 V
Coupling	DC
Probe	1:1
Bandwidth	Yes <sup>2</sup>
Threshold	2.5 V
Hys	Yes <sup>3</sup>
Slope	Yes <sup>4</sup>
Chatter Elimination	Yes <sup>5</sup>
Pull Up	Yes <sup>6</sup>

### ZeroCross

Setup Item	Setting
V Range	Yes <sup>7</sup>
Coupling	AC
Probe	Yes <sup>1</sup>
Bandwidth	Yes <sup>2</sup>
Threshold	0 V
Hys	Yes <sup>3</sup>
Slope	Rising edge
Chatter Elimination	Yes <sup>5</sup>
Pull Up	No

When you select a preset, the setup items are automatically set to the settings in the table. The meaning of Yes and No in the table is as follows:

Yes: Item that can be set to an arbitrary value

No: Item that cannot be set (not displayed on the menu)

1. Probe type: Select 1:1 or 10:1.
2. Bandwidth limit: Select 100 Hz, 1 kHz, 10 kHz, 100 kHz, or Full. Full is not selectable for AC100V and AC200V.
3. Hysteresis: Select ±1%, ±2.5%, or ±5%.
4. Slope: Select rising or falling.
5. Chatter elimination: Select from 0 ms to 1000 ms.
6. Pull-up: Select ON or OFF. Selectable only for Pull-up 5V.
7. Voltage range:  
(Probe = 1:1) Select ±1 V, ±2 V, ±5 V, ±10 V, ±20 V, or ±50 V.  
(Probe = 10:1) Select ±10 V, ±20 V, ±50 V, ±100 V, ±200 V, or ±500 V.

## Appendix 13 List of Preset Settings of the Frequency Module

### AC100V

Setup Item	Setting
V Range	±200 V
Coupling	AC
Probe	10:1
Bandwidth	Yes <sup>2</sup> (Full is not allowed)
Threshold	0V
Hys	Yes <sup>3</sup>
Slope	Rising edge
Chatter Elimination	Yes <sup>5</sup>
Pull Up	No

### AC200V

Setup Item	Setting
V Range	±500 V
Coupling	AC
Probe	10:1
Bandwidth	Yes <sup>2</sup> (Full is not allowed)
Threshold	0 V
Hys	Yes <sup>3</sup>
Slope	Rising edge
Chatter Elimination	Yes <sup>5</sup>
Pull Up	No

### EM Pickup

Setup Item	Setting
V Range	±1 V
Coupling	DC
Probe	1:1
Bandwidth	Yes <sup>2</sup>
Threshold	0 V
Hys	Yes <sup>3</sup>
Slope	Rising edge
Chatter Elimination	Yes <sup>5</sup>
Pull Up	No

### User

Setup Item	Setting
V Range	Yes <sup>7</sup>
Coupling	Yes <sup>8</sup>
Probe	Yes <sup>1</sup>
Bandwidth	Yes <sup>2</sup>
Threshold	Yes <sup>9</sup>
Hys	Yes <sup>3</sup>
Slope	Yes <sup>4</sup>
Chatter Elimination	Yes <sup>5</sup>
Pull Up	No

When you select a preset, the setup items are automatically set to the settings in the table. The meaning of Yes and No in the table is as follows:

Yes: Item that can be set to an arbitrary value

No: Item that cannot be set (not displayed on the menu)

1. Probe type: Select 1:1 or 10:1.
2. Bandwidth limit: Select 100 Hz, 1 kHz, 10 kHz, 100 kHz, or Full. Full is not selectable for AC100V and AC200V.
3. Hysteresis: Select ±1%, ±2.5%, or ±5%.
4. Slope: Select rising or falling.
5. Chatter elimination: Select from 0 ms to 1000 ms.
6. Pull-up: Select ON or OFF. Selectable only for Pull-up 5V.
7. Voltage range:
  - (Probe = 1:1) Select ±1 V, ±2 V, ±5 V, ±10 V, ±20 V, or ±50 V.
  - (Probe = 10:1) Select ±10 V, ±20 V, ±50 V, ±100 V, ±200 V, or ±500 V.
8. Coupling: Select DC or AC.
9. Threshold level: Set within the specified voltage range.

## Appendix 14 TCP and UDP Port Number Used in Ethernet Communications

The TCP and UDP port numbers that are used on the Ethernet interface of the DL750/DL750P are as follows:

### TCP Port Numbers

Port Number	Description	Function
20	File Transfer [Default Data]	FTP server, FTP client*, and a portion of the Web server
21	File Transfer [Control]	FTP server, FTP client, and a portion of the Web server
25	Simple Mail Transfer Protocol	SMTP client
80	World Wide Web HTTP	Web server and WebDAV server
515	-	LPR client
10001	-	Instrument control via the Ethernet interface

### UDP Port Numbers

Port Number	Description	Function
67	Bootstrap Protocol Server	DHCP client
68	Bootstrap Protocol Client	(receive wait port)
123	Network Time Protocol	SNTP client

\* The port number when FTP passive mode (see section 16.10) is turned OFF. If FTP passive mode is turned ON, the port number is arbitrary. If FTP passive mode is OFF, connection is established from the server. If you are connecting the DL750/DL750P behind a firewall, turn FTP passive mode ON. For the procedure of changing the FTP passive mode, see section 16.10.

## Appendix 15 Relationship between the Chart Speed, Sample Rate, and Record Length during Recorder Mode

The relationship between the chart speed, sample rate, and record length during Chart Recorder mode (see chapter 9) is as follows:

Chart Speed	Sample Rate (S/s)	Record Length (Word)	Maximum Number of Divisions That Can Be Saved	Record Time
20 mm/s	5 k	2.5 M	1000	8.33 min
10 mm/s	2 k	2 M	1000	16.66 min
5 mm/s	1 k	2 M	1000	33.3 min
2 mm/s	500	2.5 M	1000	1.38 h
1 mm/s	200	2 M	1000	2.76 h
100 mm/min	200	1.2 M	1000	1.66 h
50mm/min	200	2.4 M	1000	3.33 h
25 mm/min	100	2.4 M	1000	6.66 h
20 mm/min	50	1.5 M	1000	8.33 h
10 mm/min	20	1.2 M	1000	16.6 h
5 mm/min	20	2.4 M	1000	1.38 day
2 mm/min	5	1.5 M	1000	3.47 day
1 mm/min	5	1.5 M	500	3.47 day
100 mm/h	5	1.8 M	1000	4.16 day
50 mm/h	5	1.8 M	500	4.16 day
25 mm/h	5	1.8 M	250	4.16 day
20 mm/h	5	1.8 M	200	4.16 day
10 mm/h	5	1.8 M	100	4.16 day

The sample rates in the table above are the data acquisition rate to the internal memory when the acquisition mode is set to normal.

If the acquisition mode is set to envelope, the data is acquired at the maximum sampling rate of each input module. Then, the maximum and minimum values are determined over each interval defined by the sample rate in the table above and stored in the internal memory.

# Index

## Symbols

	Page
▼ Mark .....	7-15
μSTR .....	2-14
1 Cycle Mode .....	11-36
100BASE-TX Port .....	16-1
104 Keyboard .....	4-7, App-49
109 Keyboard .....	4-7, App-51
701250 .....	1-4
701251 .....	1-4
701255 .....	1-4
701260 .....	1-4
701261 .....	1-4
701262 .....	1-4
701265 .....	1-4
701270 .....	1-4
701271 .....	1-4
701275 .....	1-4
701280 .....	1-4
89 Keyboard .....	4-7, App-51

## A

	Page
A -> B(N) Trigger .....	2-21, 6-17
A Delay B Trigger .....	2-21, 6-20
A4 Print .....	12-9
Acceleration Measurement .....	2-15, 5-38
Acceleration Sensors .....	3-30
Acceleration/Voltage Module (with AAF) .....	1-4, 3-6, 19-35, 19-44
Accessories, Optional .....	Part 1:vii
Accessories, Standard .....	Part 1:vi
Accumulated Display .....	2-38
Accumulated Waveform Display .....	8-6
ACQ Key .....	1-8
ACQ MEMORY BACKUP switch .....	2-36
Acquisition and Display .....	19-3
Acquisition Count .....	7-6, 7-10
Acquisition Memory Backup .....	7-29, 19-8
Acquisition Memory Backup Switch .....	App-53
Acquisition Mode .....	2-31, 7-5, App-5
Acquisition Mode (Recorder Mode) .....	2-43, 9-7, 9-16
ACT LED .....	16-1
Action .....	6-46, 7-21, 11-48, 11-53
Action Mail .....	16-14, 16-19
Action Mode (Power ON) .....	6-47, 7-22
Action-on-Stop .....	2-36, 7-20
Action-on-Trigger .....	2-29, 2-36, 6-45
Adding .....	10-1
Addition .....	2-47
Addition (DSP Channel) .....	15-3
Addition with Coefficient (DSP Channel) .....	15-13
ALL CH Key .....	1-8
All Channel Setup Menu .....	5-22
All-Point Display .....	2-37
Ambient Humidity .....	3-3
Ambient Temperature .....	3-3
Analysis .....	19-4
Angle Cursor .....	2-55, 11-20, 11-27
Annotation .....	9-11, 12-12, 13-50
Arrow Key .....	1-8
ASCII Header File Format .....	App-9
Attached Image File .....	16-17

Attenuation .....	2-9, 5-9
Attenuation (Weight) .....	7-6
Author .....	9-28, 13-51
Auto (Trigger Mode) .....	2-27, 2-34, 2-43, 6-1, 7-13, 9-7
Auto Calibration .....	4-21
Auto Level (Trigger Mode) .....	2-27, 6-1
Auto Naming .....	7-17, 13-24, 13-29, 13-41
Auto OFF .....	17-6
Auto Print .....	9-18
Auto Scroll .....	2-54, 11-13, 11-15
Auto Setup .....	2-62, 4-18
Automated Measurement of Waveform Parameter .....	2-56, 11-31
Auxiliary I/O Section .....	19-10
Average .....	10-21
Average (Acquisition Mode) .....	2-31, 7-6
Average Computation .....	10-21
Averaging Mode .....	2-31
AX+B .....	2-10, 5-20

## B

	Page
B < Time Trigger .....	2-23, 6-30
B > Time Trigger .....	2-23, 6-30
B TimeOut Trigger .....	2-23, 6-30
Backing Up the Acquisition Memory .....	2-36
Backlight .....	17-6
Balancing .....	5-35
Bandwidth .....	5-10
Bandwidth Limit .....	2-9
Bandwidth Limit (Frequency Module) .....	5-51
Basic Defining Equation of Strain .....	App-54
Bias Current .....	3-30
Binary Computation .....	2-47, 10-4
Binary Conversion .....	App-17
Bit Data, Read Direction of .....	11-28
Bit Mapping .....	5-56
Block Diagram .....	2-1, 2-2
Box Average .....	7-8
Box Average (Acquisition Mode) .....	2-32, 7-6
Bridge Head .....	2-14, 3-25
Brightness .....	17-4, 17-5
Built-in Amplifier Type Acceleration Sensors .....	3-30
Built-in Printer .....	19-8
Built-in Printer Roll Paper (DL750) .....	12-1
Built-in Printer Roll Paper (DL750P) .....	9-1
Built-in Storage .....	19-9
Burnout .....	2-13, 5-30
Butterworth Filter .....	App-33
Buzzer (Action) .....	2-29, 2-36, 2-58, 6-46, 7-21, 11-48, 11-53

## C

	Page
Calibration .....	4-21
Center .....	6-39
CH Data .....	9-11, 12-12
CH Information .....	9-11, 12-12
CH Message .....	9-11, 12-12
Changing the File Attribute .....	13-56
Channel Information .....	2-39, 8-22
Charge Output Type Acceleration Sensors .....	3-30
Chart Recorder Mode .....	2-43, 9-5
Chart Speed .....	9-7
Chatter Elimination .....	5-51

## Index

Clear Trace .....	8-15
CLEAR TRACE Key .....	1-9
Clearing Trace .....	2-42
Click Sound .....	17-1
Color .....	17-5
Combining of the Bit Data .....	11-29
Communication Interface User's Manual ... Part 1:iv, Part 2:iii	
COMP Output .....	19-11
Compensating the Probe .....	3-21
Compensation Signal .....	3-22
Compression .....	9-28, 13-51
Computation Delay .....	15-2, App-24
Computation Flow (DSP Channel) .....	App-45
Computer Interface .....	19-13
Connect Log List .....	16-22
Constant .....	10-22
Control Script .....	16-23, 16-42
Control Script Window .....	16-42
Converting Realtime Recorded Waveform .....	13-53
Copying File .....	13-60
Coupling .....	2-8, 5-7
Coupling (Frequency Module) .....	5-51
Creating a PDF File of the Reprint Image .....	2-46
Current Probe .....	3-18
Cursor .....	11-17
Cursor Jump .....	11-22
CURSOR Key .....	1-8
Cursor Measurement .....	2-55, 11-17
Cursor Position .....	11-30
Cycle Averaging .....	10-21
Cycle Frequency .....	6-43
Cycle Statistical Processing .....	2-57, 11-42

<b>D</b>	<b>Page</b>
Damping Rate .....	10-10
Dark/Light .....	9-10, 9-19, 12-11
Data Capture .....	16-23, 16-32
Data Capture Window .....	16-33
Data Interpolation .....	8-4
Data Points, Number of .....	8-4
Data Storage .....	19-7
Date and Time .....	3-13
Deceleration Prediction .....	2-17, 5-54
Decimation .....	8-4, 8-14
Decimation Display .....	2-37
Default Gateway .....	16-5
Degree Cursor .....	2-55
Delay .....	6-22, 11-35
Details .....	9-11, 12-11, 13-50
Determination Logic .....	11-47, 11-52
Determination Mode .....	11-47, 11-52
Determination Zone .....	11-47
DHCP .....	16-5
Differential Probe .....	3-20
Differentiation .....	App-16
Differentiation (DSP Channel) .....	15-10, App-44
Digital Filter .....	2-48, 10-21, App-14
Digital Filter Computation (DSP Channel) .....	App-23
Direction .....	9-15
Display .....	19-3
Display Bits .....	5-56, 5-58
Display Format .....	8-1
Display Format of Logic Waveforms .....	11-28
Display Interpolation .....	2-37
DISPLAY Key .....	1-8
Displayed Record Length .....	2-31
Displaying Waveforms on a Full Screen .....	8-22

Div/Page .....	9-28
Dividing .....	10-1
Division .....	2-47
Division (DSP Channel) .....	15-3
Division with Coefficient (DSP Channel) .....	15-13
DNS .....	16-6
DNS Server .....	16-6
Document Information .....	9-28, 13-51
Domain Suffix .....	16-6
Dot Display .....	2-4
Drive Letter .....	13-69
DSP Channel .....	2-50, 15-1
DSP Channel Computation .....	19-5, App-23
Dual Capture .....	2-34, 7-11
DUAL CAPTURE Key .....	1-8
Dual Zoom .....	2-41, 8-10
Duty Cycle .....	5-52
Duty Cycle Measurement .....	2-16, 5-40

<b>E</b>	<b>Page</b>
E-mail Message .....	16-14
Earphone Microphone with a PUSH Switch .....	3-33
Edge .....	11-15
Edge on A Trigger .....	2-22
Edge Or .....	6-25
Edge Search .....	2-54, 11-11
Edge Trigger .....	6-8
Electromagnetic Pickup .....	3-32
Elimination Level .....	15-19
Enhanced Trigger .....	2-21
Entering String .....	4-4
Entering Value .....	4-3
Envelope (Acquisition Mode) .....	2-32, 7-6, 8-4
Error Message .....	18-2
Errors in Execution .....	18-3
Errors in Setting .....	18-5
Ethernet .....	2-59
Ethernet Connector .....	19-13
Ethernet interface .....	16-1
Event .....	2-19
Event Waveform .....	5-57
Execution Mode of the Action-on Trigger at Power ON ...	6-47
Execution Mode of the Action-on-Stop at Power ON .....	7-22
Expanding the Waveform Area .....	8-22
Exponential (Window) .....	10-9
Exponential Averaging .....	2-49
Exponential Window .....	2-48, App-21
EXT CLK IN .....	14-3
External Clock .....	2-3, 5-26
External Clock Input .....	14-3
External Start/Stop .....	19-11
External Start/Stop Input .....	14-6
External Trigger .....	2-20, 6-11
External Trigger Input .....	14-1, 19-10
Extra Area .....	9-10, 12-10
Extra Window .....	2-38, 8-19

<b>F</b>	<b>Page</b>
FEED Key .....	1-9
Feeding the Paper .....	9-3, 12-3
FFT Function .....	2-48, App-18
FFT Point .....	10-9
FFT Window .....	10-22
FILE Key .....	1-9
File Operation Errors .....	18-8
File Setup .....	9-15

Filter	2-15, 2-17, 5-54, 10-21
Filter (DSP Channel)	15-6
Filter Format	2-50, 15-18
Fine	12-9
Flange	9-2
FlatTop	2-47
Flattop	10-9
Flexible Zone	9-10, 12-11
Floppy Disk	13-1
Floppy Disk Drive	19-9
Flow of Operation	Part 1: xv, Part 2: vi
Font Size	9-19
Force 1	10-10
Force 2	10-10
Force Window	App-21
Format	8-2, 9-9, 12-9
Formatting the Storage Medium	13-10
FREE	9-2, 12-2
Frequency	5-52
Frequency Characteristics	5-8
Frequency Measurement	2-16, 5-40
Frequency Module	1-4, 3-6, 3-32, 19-37, 19-44
Front Panel	1-2
FTP Client	2-59, 16-8
FTP Passive Mode	16-51
FTP Server	2-60, 16-11, 16-20
FTP Server (On the Web Browser)	16-23, 16-31

<b>G</b>	<b>Page</b>
Gauge Factor	2-14, 5-35
Gauge Print	9-11, 12-11, 13-50
GAUSS Filter	App-31
General Specification	19-14
GO OUT	11-56
GO/NO-GO Determination	2-58, 11-55
GO/NO-GO Determination I/O	19-11
GO/NO-GO Determination I/O Terminal Connector	11-55
GO/NO-GO Determination Using Measured Waveform Parameters	11-50
GO/NO-GO Determination Using Zone	11-44
GP-IB	2-59, 19-13
Graticule	2-38, 8-5, 9-10, 9-19, 12-11
Greenwich Mean Time	16-25, 16-48
Ground Level	5-6
Group Delay Characteristics	App-24
Guide	9-2, 12-2

<b>H</b>	<b>Page</b>
H (Horizontal) Cursor	2-55, 11-17, 11-23
H&V	11-27, 11-28
H&V Cursor	2-55, 11-21, 11-25
Handling Precaution	3-1
Hanning	2-47, 10-9
Help	4-22
HELP Key	1-9
Help Window	4-22
High and Low Setting	11-37
High Level	14-2
High Voltage Differential Probe	3-20
High-Speed 10 MS/s, 12-Bit Isolation Module	1-4, 3-6, 19-18, 19-44
High-Speed 10 MS/s, 12-Bit Non-Isolation Module	1-4, 3-6, 19-22, 19-44
High-Speed High-Resolution 1 MS/s, 16-Bit Isolation Module	1-4, 3-6, 19-20, 19-44

High-Speed Logic Probe	3-28
High-Voltage 100 kS/s, 16-Bit Isolation Module (with RMS)	1-4, 3-6, 19-24, 19-44
Hilbert	App-15
HISTORY Key	1-8
History Memory	2-33
History Search	2-53, 11-5, 11-8
History Waveform	11-1
HOLD	9-3, 12-2
Hold Off Time	6-6, 6-7
Horizontal	11-27, 11-28
Horizontal Axis	2-3
How to Calculate the Area of a Waveform	App-7
HS10M12	1-4
HS1M16	1-4
HV (with RMS)	1-4
Hysteresis (Frequency Module)	5-51

<b>I</b>	<b>Page</b>
IIR Filter	App-33
Image (Action)	2-29, 2-36, 2-58, 6-46, 7-21, 11-48, 11-53
Image Control	16-33
IMAGE SAVE Key	1-9
Indicator	7-1
Information Window	16-46
Initialization	2-61
Initializing Setting	4-16
Input Coupling	2-8, 5-7
Input Module	Part 1: vi, 1-4, 3-5
Input Section	19-1
Input Signal Trigger	2-20
Installation Condition	3-3
Installation Position	3-4
Installation Procedure of Module	3-6
Instrument Control	16-35
Instrument Information	16-23, 16-46
Instrument Number	Part 1: v
Integration	App-16
Integration (DSP Channel)	15-10
Intensity	17-5
Internal Clock	2-3, 5-26
Internal Computation Format (DSP Channel)	App-45
Internal Hard Disk	13-6, 19-9
Interpolation	8-4, 9-18
Interval	9-15, 16-17
Inverted Display	2-10
Inverting Waveform	5-21
IP Address	16-5
Isolated Logic Probe	3-28

<b>J</b>	<b>Page</b>
Jog Shuttle Operation	4-1

<b>K</b>	<b>Page</b>
Key Operation	4-1
Key Test	18-15
KeyWord	9-28, 13-51
Knobs	1-7
Knocking Filter	15-16

## Index

<b>L</b>	<b>Page</b>
LCD OFF Exec .....	17-6
LEDs on the Frequency Module .....	3-7
Left Side Panel .....	1-5
Level Indicator .....	2-38, 8-21
Line Trigger .....	2-20
Linear Averaging .....	2-48
Linear Interpolation .....	2-37
Linear Scaling . 2-10, 5-18, 10-3, 10-6, 10-10, 10-13, 10-22	
Link .....	16-23, 16-47
LINK LED .....	16-1
List of Default .....	App-46
Loading Data on the Storage Medium .....	2-63
Loading Snapshot Waveform .....	13-31
Loading the Setup Data .....	13-26
Loading the Waveform Data .....	13-17
Locking the Key .....	17-7
Log .....	16-23, 16-44
Log (Trigger Mode) .....	2-27, 2-34, 2-44, 7-13, 9-7
Log Mode .....	6-2
Log Window .....	16-44
Logic .....	11-47, 11-52
Logic Input .....	19-10
Logic Input Connector .....	3-28
Logic Probe .....	3-28
Logic Trigger .....	6-15
Logic Waveform .....	2-19, 5-55
Login Name .....	16-11
Low Level .....	14-2
LPR Name .....	16-13
LPR Server .....	16-13
LPR/SMTP Timeout .....	16-51

<b>M</b>	<b>Page</b>
MAC Address .....	16-50
Mail Address .....	16-17
Mail Server .....	16-17
Mail Test .....	16-17
MailBaseTime .....	16-17
Main Waveform .....	2-34, 7-13
MAN FEED .....	12-2
Manual Reset .....	5-53
MANUAL TRIG Key .....	1-7
Manual Trigger .....	2-30, 6-48
Manuals .....	Part 1:iii, Part 2:ii
Mapping .....	8-2
Marker .....	11-27, 11-28
Marker Cursor .....	2-55, 11-19, 11-26
MATH Key .....	1-8
Maximum Number of Acquisitions of History Memory ...	App-5
Maximum Record Length .....	App-5
Maximum Sample Rate .....	5-2
MEAN Filter .....	App-43
MEASURE Key .....	1-8
Measurement Principles of the Frequency Module .....	App-60
Measurement Resolution .....	2-5
Measurement Trend .....	16-23, 16-38
Measurement Trend Window .....	16-38
Measuring Lead .....	3-23, 3-28
Memory Test .....	18-15
Menu Language .....	17-1
Message and Corrective Action .....	18-2
Message Language .....	17-1
MISC Key .....	1-9
MODE Key .....	1-7
MODEL .....	Part 1:v
Module .....	3-5, 19-44

Module Specification .....	19-18
Monitor & Capture .....	16-33
Moving Average .....	2-17, 7-9, App-43
Multiplication .....	2-47
Multiplication (DSP Channel) .....	15-3
Multiplication with Coefficient (DSP Channel) .....	15-13
Multiplying .....	10-1
mV/V .....	2-14

<b>N</b>	<b>Page</b>
Network Drive .....	16-52
Network Error .....	18-11
Network Printer .....	16-12
No. ....	Part 1:v
NOGO OUT .....	11-56
NONISO_10M12 .....	1-4
Normal .....	12-9
Normal (Acquisition Mode) .....	2-31, 7-6
Normal (Trigger Mode) .....	2-27
Normal Mode .....	2-27, 2-31, 6-2
Normal Statistical Processing .....	2-57, 11-42
Normal Waveform Display .....	1-10
Notation .....	11-28
NUM KEY .....	1-9, 2-61, 4-6
Number of Rotations Measurement .....	2-16, 5-40
Numeric .....	9-5
Numeric Monitor .....	2-39, 8-23
Numeric Value .....	2-38, 8-21
Numeric Value Recording .....	2-43

<b>O</b>	<b>Page</b>
Offset .....	2-18
Offset Value .....	2-6, 5-16
Operation Guide .....	Part 1:iv, Part 2:iii
Operator .....	10-19
Options .....	Part 1:v
OR Trigger .....	2-22, 6-27
Orientation .....	9-28, 13-51
Other Error .....	18-12
Output Device .....	9-15
Output File .....	9-15
Output Format .....	12-9, 16-13
Output Interval .....	9-15
Output Resolution .....	12-17, 12-19
Over Limit Reset .....	5-53
Overall Value .....	App-19
Overview .....	18-16

<b>P</b>	<b>Page</b>
P-P Compression .....	2-3
P1-P2 .....	2-10, 5-20
Panel Keys .....	1-7
Paper Feed Knob .....	12-2
Paper Size .....	9-28, 13-51
Partition .....	13-13
Password .....	16-11, 16-22
PC Card .....	13-4
PC Card Drive .....	19-9
PC Environment (Web Server) .....	16-24
PDF File (of the Reprint Image) .....	9-26
PDF File (Printed Image) .....	13-46
Peak Computation .....	10-21
Period .....	5-52
Period Measurement .....	2-16, 5-40
Period Trigger .....	2-24, 6-34



Periodic Mail .....	16-14, 16-18
Persistence Mode .....	8-7
Phase .....	App-15
Phase Correction .....	3-21
Phase Shift .....	2-48, 10-22
Phase-Shifted Display .....	10-11
Pointer .....	9-19
POSITION Key .....	1-7
Power Cord .....	3-8
Power Signal .....	6-12
Power Spectrum .....	10-7
Power Spectrum Display .....	2-47
Power Supply .....	3-8
Power Supply Frequency .....	5-52
Power Supply Frequency Measurement .....	2-16, 5-40
Power Switch, Turning ON/OFF .....	3-8
Preset .....	5-50
Preset Settings .....	App-64
Preview .....	9-24, 12-12
PRINT .....	6-46
PRINT (Action) .....	2-29, 2-36, 2-58, 7-21, 11-48, 11-53
Print Direction .....	9-15
Print Font .....	9-19
PRINT Key .....	1-9
Print Mag .....	9-23, 9-28, 13-50
Print Magnification .....	13-50
Print Setup .....	12-10, 13-50
Print Style .....	9-5
Print to .....	9-23, 9-28, 13-50
Printer Errors .....	18-10
Printer Name .....	16-13
Printer Output .....	9-7
Printer Test .....	18-15
Printing (Built-in Printer) .....	12-4
Printing (Network Printer) .....	2-59, 12-18
Printing (USB Printer) .....	12-14
Printing Screen Image Data .....	2-62
Printing Using Normal Output Format .....	12-10
Probe .....	3-15, 5-9
Probe Attenuation .....	2-9, 5-9
Probe Power Output .....	19-12
Probe Power Supply Terminal .....	3-19
Probe Type .....	5-51
Property .....	13-59, 13-62, 13-66
PROTECT Key .....	1-9, 17-7
Protective Earth Ground Terminal .....	3-8
Pull Up .....	5-51
Pulse Average .....	2-18, 5-54
Pulse Integration .....	5-52
Pulse Integration Measurement .....	2-16, 5-40
Pulse Width .....	5-52, 6-33
Pulse Width Computation .....	App-18
Pulse Width Measurement .....	2-16, 5-40
Pulse Width Trigger .....	6-30
Pulse/Rotate .....	2-11, 5-27
PUSH OPEN Button .....	12-2

**R****Page**

Realtime Recording .....	2-35, 2-43, 7-16, App-6
Realtime Template .....	6-41
Recommended Replacement Part .....	18-17
Record Conditions .....	9-6
Record Length .....	2-31, 7-3, App-1, App-5
RECORDER Key .....	1-8
Recorder Mode .....	2-43, 9-4
Recording Format .....	9-8
Recording Numeric Values .....	9-14

Rect (Rectangular) .....	2-47, 10-9
Rectangular .....	App-21
Reference Cycle .....	6-43
Reference Junction Compensation .....	2-13
Release Arm .....	12-2
Repeat .....	2-44, 9-7
Reprinting .....	9-21, 9-23, 9-24
Reprinting on the Built-in Printer .....	2-46
RESET Key .....	1-8
Resolution .....	6-9, 12-17, 12-19
Right Side Panel .....	1-3
RJC .....	2-13, 5-30
RMS Measurement .....	2-12
RMS Value .....	5-28
Roll Mode Display .....	2-4
Roll Paper .....	9-1, 12-1
Roll Paper Flange .....	9-2
Roller .....	12-2
RPMs .....	5-52
RPSs .....	5-52
Rubber Feet .....	3-4

**S****Page**

Sample Rate .....	2-4
Sample Rate (Recorder Mode) .....	9-18
Save to File (Action) .....	2-29, 2-36, 2-58, 6-46, 7-21, 11-48, 11-53
Saving Data on the Storage Medium .....	2-63
Saving Screen Image Data .....	13-38
Saving the Results of the Automated Measurement of Waveform Parameters .....	13-35
Saving the Setup Data .....	13-26
Saving the Waveform Data .....	13-17
Scale Value .....	2-38, 8-17
Scaling .....	2-10, 5-18, 10-3
Screen Color .....	17-4
Screen Display Font Size .....	17-2
Screen Image Data Output .....	19-6
SCSI .....	2-65, 13-9, 13-69, 19-9
SCSI ID Number .....	13-15
Search and Zoom .....	2-54, 11-11
Search by Zone .....	2-53
Search Parameter .....	11-10
Search Window .....	11-7
Search Zone .....	11-7
Searching History Memory Data Using Zone .....	11-5
SELECT Key .....	1-8
Self Test .....	18-13
Self-Diagnostic Test .....	18-13
Send Mail (Action) .....	2-29, 2-36, 2-58, 6-46, 7-21, 11-48, 11-53
Sequence .....	11-47, 11-52
Sequential Store .....	2-27, 2-33, 7-10
Serial (RS-232) .....	2-59, 19-13
SETUP Key .....	1-8
SHARP Filter .....	App-25
SHIFT Key .....	1-9
Shot Recording .....	9-7
Show Map .....	11-3
Shunt Calibration .....	5-36, App-55
Shunt Resistance, Calculation of .....	App-57
Simple Trigger .....	2-20
SIMPLE/ENHANCED Key .....	1-7
Sine Interpolation .....	2-37
Single (N) (Trigger Mode) .....	2-27, 6-2, 7-10
Single (Trigger Mode) .....	2-27, 2-44, 6-2, 9-7
Slope (Frequency Module) .....	5-51

## Index

Smoothing	5-54
Smoothing Filter	2-17, App-63
SNAP SHOT Key	1-9
Snapshot	2-41, 8-15
SNTP	3-13, 16-48
Spare Parts	Part 1:viii
Speaker (Voice Memo/Voice Comment)	3-33
Speaker Output	19-12
Speaker Output Terminal	3-35
START IN	11-55
Start Mode (Power On)	App-53
START/STOP Key	1-8
Starting/Stopping Waveform Acquisition	7-1
Statistical Processing	2-57
Statistical Processing of History Data	2-57, 11-43
Statistical Processing Per Cycle	11-38
Status Message	18-2
Stop Prediction	2-17, 5-54
Storage	19-9
Storage Media View Window	16-31
STP (Shielded Twisted-Pair) Cable	16-1
Strain	2-14
Strain Gauge	3-25
Strain Measurement	2-14, 5-31
Strain Module	3-25
Strain Module (DSUB, Shunt-Cal)	1-4, 3-6, 19-33, 19-44
Strain Module (NDIS)	1-4, 3-6, 19-31, 19-44
STRAIN_DSUB	1-4
STRAIN_NDIS	1-4
Sub Title	9-28, 13-51
Sub Waveform	2-34, 7-13
Subnet Mask	16-5
Subtracting	10-1
Subtraction	2-47
Subtraction (DSP Channel)	15-3
Subtraction with Coefficient (DSP Channel)	15-13
SUFFIX	Part 1:v
Symbol	Part 1:ix
Synchronization Channel	6-43
System Condition	18-16
System Configuration	2-1
System Operation Error	18-7

<b>T</b>	<b>Page</b>
T < T1, T2 < T	2-25, 6-36
T < Time	2-24, 6-36
T > Time	2-24, 6-36
T-Y Waveform Recording	2-43, 9-6, 9-8, 9-12
T/div	5-2
T1 < T < T2	2-24, 6-36
TCP/IP	16-3
TEMP/HPV	1-4
Temperature, High Precision Voltage Isolation Module	1-4, 3-6, 19-29, 19-44
Temperature Measurement	2-13, 5-29
Test Mail, Sending of	16-17
Thermocouple	2-13, 3-24, 5-30
Threshold Level (Frequency Module)	5-51
Threshold Level of Binary Computation	10-22
Thumbnail	2-63, 13-42
Time Axis	2-3, 19-2
Time Axis Setting	App-1
Time Base	2-3, 5-25
Time of Satisfaction	6-36
Time Out	16-11, 16-22
Time Print	9-11, 12-11, 13-50
Time Reference Mark	6-4

Time Window	10-9, App-21
TIME/DIV Knob	1-7
Timer Trigger	2-20, 6-13
Title	9-28, 13-51
Top Panel	1-1
Transducer Output	2-14
Translucent Mode	8-16
Translucent Mode Display	2-38
Transmission Interval	16-17
Transmission Time	16-17
Transmitting E-mail Message	2-60
TRIG IN	14-1
TRIG OUT	14-2
Trigger	2-20
Trigger Delay	2-28, 6-5
Trigger Hold Off	6-6
Trigger Hysteresis	2-29, 6-10, 6-19, 6-22, 6-26, 6-29, 6-33, 6-36, 6-39
Trigger Level	2-28, 6-9, 6-19, 6-22, 6-26, 6-29, 6-33, 6-36
Trigger Mode	2-27, 6-1
Trigger Mode (Recorder Mode)	2-43, 9-7, 9-16
Trigger Output	14-2, 19-10
Trigger Point	2-28
Trigger Position	2-28, 6-3, 6-14
Trigger Section	19-1
Trigger Slope	2-28, 6-10, 6-11, 6-16
Trigger Source	2-28, 6-9, 6-11, 6-12, 6-14, 6-16
Troubleshooting	18-1
Turning Channels ON/OFF	5-1
Type	12-11
Type (Graticule)	9-10, 9-19

<b>U</b>	<b>Page</b>
Universal (Voltage/Temp.) Module	19-26
Update Mode	2-4
USB	2-59
USB Keyboard	2-61, 4-7, App-49
USB Keyboard Language	17-3
USB Mouse	2-61, 4-10
USB PERIPHERAL Connector	4-7, 4-10, 12-16
USB PERIPHERAL Interface	13-7, 19-10
USB Storage Device	13-7
USB-PC Connection	19-13
User Account	16-25
User Name	16-22
User-Defined Computation	2-48, 10-14, App-14
User's Manual Part 1	Part 1:iii, Part 2:ii
User's Manual Part 2	Part 1:iii, Part 2:ii
UTP (Unshielded Twisted-Pair) Cable	16-1

<b>V</b>	<b>Page</b>
V (Vertical) Cursor	2-55, 11-18, 11-24
V/div	5-3
V/DIV Knob	1-7
Variable	5-15
Velocity	5-52
Velocity Measurement	2-16, 5-40
Version	Part 1:xiii, Part 2:iv
Vertical	11-27, 11-28
Vertical Axis	2-5
Vertical Position	2-6, 5-5
Vertical/Horizontal Axis Setting	19-4
VIDEO OUT (SGVA)	14-4
Video Signal Output	14-4, 19-11
Voice Comment	2-64, 13-70
Voice Input/Output	19-11

Voice Memo .....	2-36, 7-23
VOICE MEMO Key .....	1-9
Voice Memory Indicator .....	7-24, 7-25
Voice Search .....	11-14
Voltage Axis .....	2-5
Voltage Range (Frequency Module) .....	5-51
Voltage Sensitivity .....	2-5

## **W** **Page**

Wave .....	9-5
Wave Window Trigger .....	2-26, 6-40
Waveform Acquisition .....	7-1
Waveform Acquisition Mode at Power ON .....	7-2
Waveform Computation .....	2-47
Waveform Label .....	2-38, 8-18
Waveform Mapping .....	2-37, 8-2
Waveform Parameter Search .....	2-53, 11-8
Web Server .....	2-60, 16-23
Web Server Window .....	16-27
WebDAV .....	16-52
Width .....	6-39, 9-10, 9-19, 12-11
Window .....	6-39
Window Trigger .....	2-25, 6-37

## **X** **Page**

X-Y Recorder Mode .....	2-46, 9-5
X-Y Waveform .....	8-12
X-Y Waveform Display .....	2-40
X-Y Waveform Recording .....	9-17

## **Z** **Page**

Zip Disk .....	13-2
Zip Drive .....	19-9
Zone Number .....	11-47
Zoom .....	2-41
ZOOM Key .....	1-8
Zoom Position .....	5-13, 8-11, 15-2
Zoom Print .....	12-9
Zoom Rate .....	5-13, 8-10
Zooming .....	8-8
Zooming Horizontally .....	2-4, 8-8
Zooming in on the Waveform Horizontally .....	2-41
Zooming in or out of the Vertical Axis .....	2-7
Zooming Vertically According to the Upper and Lower .....	2-7, 5-14, 5-15
Zooming Vertically by Setting the Zoom Rate .....	2-7, 5-12