

# Keysight 86100D

## DCA Wide-Bandwidth Oscilloscope Family

### Configuration Guide



## Table of Contents

86100D Infiniium DCA-X Wide-Bandwidth Oscilloscope Mainframe .....	03
54754A Differential and Single-ended TDR/TDT Module.....	05
86105C 9 GHz Optical/20 GHz Electrical Sampling Module, 750 to 1650 nm—SMF and MMF .....	06
86105D 20/34 GHz Optical, 35/50 GHz Electrical Module, 750 to 1650 nm, MMF and SMF.....	07
86108B Precision Waveform Analyzer .....	08
86112A 20 GHz Dual Channel Electrical Module.....	09
86115D 20/34 GHz Multi-Port 86100 Plug-in Module for High-Volume/Parallel Optical Transceiver Test.....	10
86116C 40 to 65 GHz Optical and 80 GHz Electrical Plug-in Modules .....	11
86118A 70 GHz Dual Remote Sampling Head Module .....	12
N1045A 60 GHz 2/4 Port Electrical Remote Sampling Head Module .....	13
N1046A 75/85/>100 GHz 1/2/4 Port Electrical Remote Sampling Head Module.....	14
N1055A 35/50 GHz 2/4 Port TDR/TDT Remote Sampling Head Module .....	15
N1076A Electrical Clock Recovery .....	16
N1076B Electrical Clock Recovery .....	17
N1077A Optical/Electrical Clock Recovery.....	18
N1078A Optical/Electrical Clock Recovery .....	19
N1090A DCA-M Sampling Oscilloscope.....	20
N1092A/B/C/D/E 1/2/3/4 Channel Optical DCA-M Sampling Oscilloscope.....	21
N1094A/B 2/4 Channel Electrical DCA-M Oscilloscope.....	23
N1027A Oscilloscope Accessories for DCA Family .....	24
Appendix: Dependencies of Options and Software Licenses.....	25
Appendix: DCA Input Connectors .....	26
Appendix: RF/Microwave Connectors.....	27
Appendix: Literature References.....	27



## 86100D Infiniium DCA-X Wide-Bandwidth Oscilloscope Mainframe

The 86100D DCA-X Wide-Bandwidth Oscilloscope is a modular platform that provides accurate and precise measurements on high-speed digital designs from 50 Mb/s to more than 80 Gb/s. Users configure the 86100D DCA-X mainframe by selecting from a variety of plug-in modules that perform precision optical, electrical, and TDR/TDT measurements. Select specific modules to obtain the desired bandwidth, filtering, and sensitivity that match your measurement needs.

- Flexible, modular platform
- Precision measurements on high-speed signals
- Powerful analysis features
- Lowest cost of test

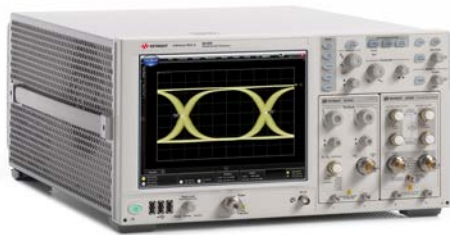

### Hardware options

86100D-STR	Standard trigger
86100D-ETR	Enhanced trigger
86100D-PTB	Internal precision timebase <sup>1</sup>
86100D-GPI	GPIO card interface installed
86100D-GPN	No GPIO card interface
86100D-090	Removable hard drive
86100D-092	Internal hard drive

### Software options

86100D-061	MATLAB - Basic Oscilloscope package <sup>5</sup>
86100D-062	MATLAB - Standard Oscilloscope package <sup>5</sup>
86100D-200	Enhanced jitter analysis software <sup>1</sup>
86100D-201	Advanced waveform analysis software <sup>5</sup>
86100D-202	Enhanced impedance and S-parameter software
86100D-300	Amplitude analysis/RIN/Q-factor <sup>2</sup>
86100DU-400	PLL and jitter spectrum software <sup>3</sup>
86100DU-401	Advanced EYE analysis software
86100D-SIM	InfiniiSim-DCA software <sup>1</sup>
86100D-500	Productivity package software
86100D-9FP	PAM-N analysis software <sup>6</sup>
86100D-TFP	IEEE TDECQ analysis, fixed perpetual license
86100D-BFP	Automatic Fixture Removal (TDR mode)
86100D-EFP	FlexEye Independent Channel Acquisition and Control

### Misc options

86100D-AFP	Module slot filler panel
86100D-AX4	Rack mount flange kit
86100D-AXE	Rack mount flange kit with handles
86100D-UK6	Commercial cal certificate with test data

1. Options 200, 201, PTB and SIM require Option ETR.
2. Option 300 requires Options 200 and ETR.
3. Option 400 requires Microsoft Office Excel 2003/2007/2010.
4. Option 401 requires Options ETR/200 for DDPWS measurement.
5. Options 061 and 062 require options 201 and ETR.
6. Options 200/201/300/401 recommended for 9FP.



## 86100D Infiniium DCA-X Wide-Bandwidth Oscilloscope Mainframe (Continued)

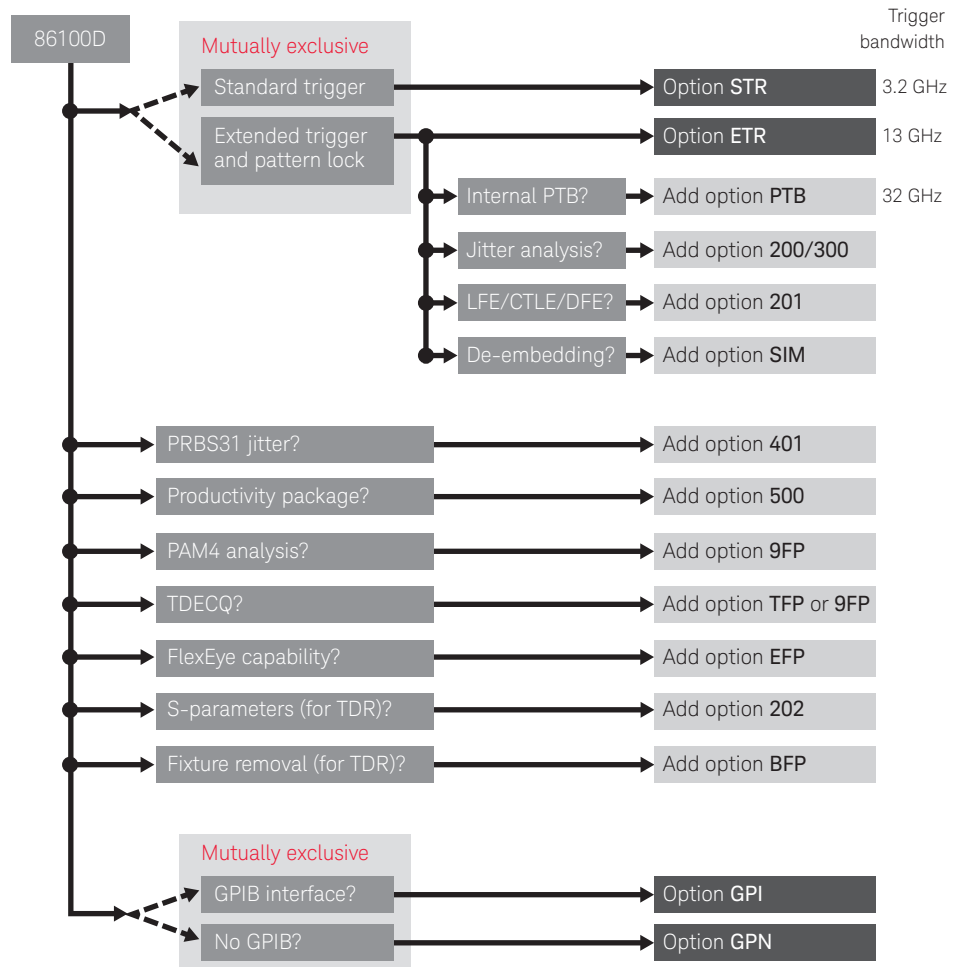

## 54754A Differential and Single-ended TDR/TDT Module

Provides two 18-GHz channels that have built-in TDR step generators. The two channels work in tandem to provide differential or common mode TDR stimulus/response, or can be used independently. Either channel works as a normal oscilloscope vertical channel when the TDR/TDT step generators are not operating.

- Single-ended or differential operation
- Edge speed (10 to 90%, typical): 35 ps
- Compatible with 86100A/B DCA, 86100C DCA-J and 86100D DCA-X mainframes



Model/option number	Description
54754A	Differential TDR module
N1021B	Differential TDR probe kit <sup>1</sup>
N1024B	TDR calibration kit

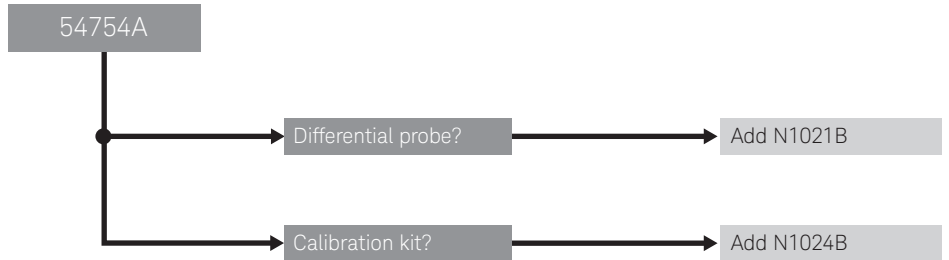

86100D-202 enhanced impedance and S-parameter software highly recommended.

1. See [www.keysight.com/find/N1021B](http://www.keysight.com/find/N1021B).



## 86105C 9 GHz Optical/20 GHz Electrical Sampling Module, 750 to 1650 nm—SMF and MMF

The 86105C plug-in module offers unprecedented wavelength and optical filter coverage for SONET/SDH and datacom/enterprise technologies up to 11.3 Gb/s.

- 9 GHz amplified optical channel for 9/125 to 62.5/125 fibers
- 20 GHz electrical channel with 3.5 mm male input
- Compatible with 86100A/B DCA, 86100C DCA-J and 86100D DCA-X mainframes



Model/option number	Description
86105C	9 GHz optical; single-mode and multimode, amplified (750 to 1650 nm), 20 GHz electrical
86105C-100	155 Mb/s through 6.25 Gb/s (choose exactly 4 filter rates)
86105C-110	155 Mb/s
86105C-120	622 Mb/s (also covers 614 Mb/s)
86105C-130	1.063 Gb/s
86105C-140	1.244/1.250 Gb/s (also covers 1.229 Mb/s)
86105C-150	2.125 Gb/s
86105C-160	2.488/2.500 Gb/s (also covers 2.458 Gb/s)
86105C-170	2.666 Gb/s
86105C-180	3.125 Gb/s (also covers 3.072 Gb/s)
86105C-190	4.250 Gb/s
86105C-193	5.0 Gb/s
86105C-195	6.250 Gb/s (also covers 6.144 Gb/s)
86105C-200	8.5, 9.953, 10.3125, 10.519, 10.664, 10.709, 11.096, 11.317 Gb/s
86105C-300	Combination of rates available in 86105C-100 and 86105C-200
86105C-IRC	System impulse response correction calibration

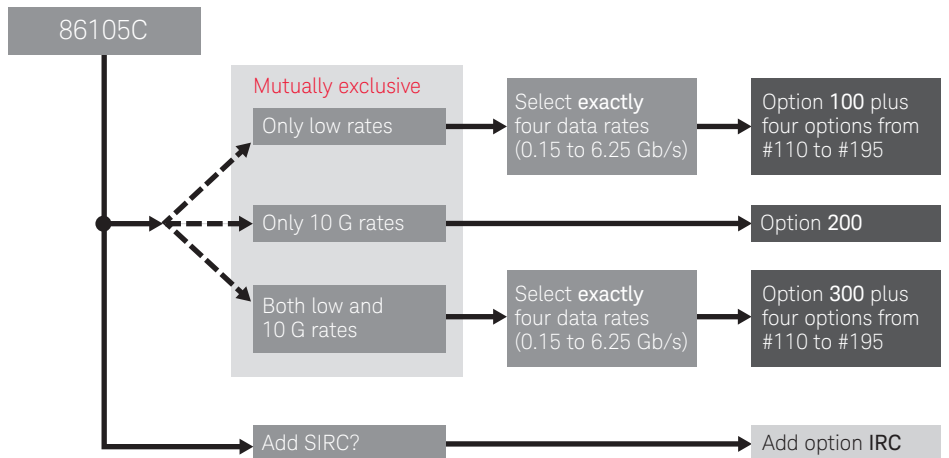

## 86105D 20/34 GHz Optical, 35/50 GHz Electrical Module, 750 to 1650 nm, MMF and SMF

- 20 or 34 GHz optical bandwidth, 750 to 1650 nm, for 8.5 to 28 Gb/s transceiver test
- 35 or 50 GHz electrical channel with 3.5 or 2.4 mm connector
- Compatible with 86100C DCA-J and 86100D DCA-X mainframes



Model/option number	Description
86105D-141	20 GHz optical channel; single-mode and multimode, (750 to 1650 nm); filters for 8.5, 9.953, 10.3125, 10.519, 10.664, 10.709, 11.096, 11.317, 14.025 Gb/s; 35 GHz electrical channel
86105D-100	Identical capability as 86105D-141, 14.025 Gb/s filter not included
86105D-200	Identical capability as 86105D-141, only filter provided is 14.025 Gb/s
86105D-281	34 GHz optical channel, filters for 15, 25.78 , 27.95, 28.05 Gb/s (contact Keysight for how to cover 14.025 Gb/s), 50 GHz electrical channel
86105D-168	25 Gb/s TDEC filter <sup>1</sup>
86105D-206	20.625 Gb/s filter <sup>1</sup> . 15 Gb/s filter is removed
86105D-IRC	System impulse response correction calibration

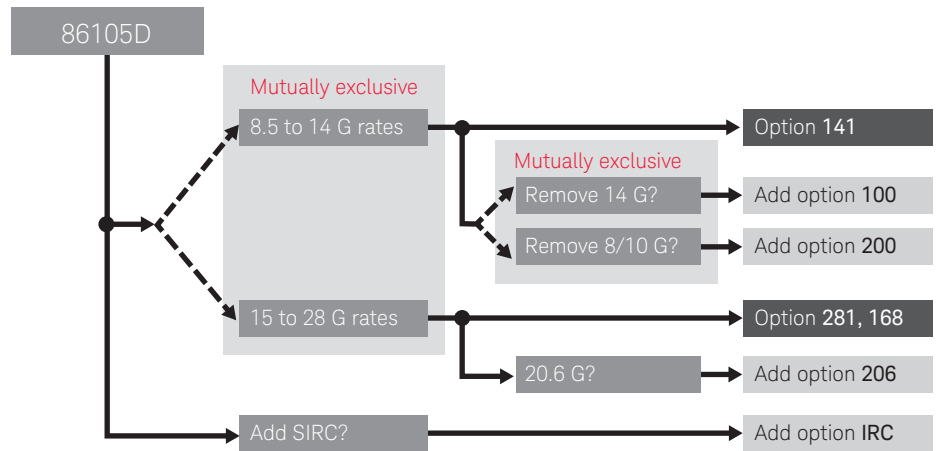

1. Options 168 and 206 require Option 281.



## 86108B Precision Waveform Analyzer

The 86108B Precision Waveform Analyzer, engineered for design and validation engineers that are faced with the difficult task of accurately characterizing the TRUE performance of their designs, combines three modules into one for unprecedented performance:

- Differential 35 or 50 GHz measurement channels
- 50 Mb/s to 16 Gb/s or 32 Gb/s clock recovery
- Precision timebase with residual jitter well below 45 femtoseconds
- Compatible with 86100C DCA-J and 86100D DCA-X mainframes

Model/option number	Description
86108B-LBW	Dual 35 GHz electrical channels (3.5 mm inputs)
86108B-HBW	Dual 50 GHz electrical channels (2.4 mm inputs)
86108B-216	Clock recovery 50 Mb/s to 16 Gb/s
86108B-232	Clock recovery 50 Mb/s to 32 Gb/s
86108B-300	Adjustable loop bandwidth/peaking
86108B-400	Auxiliary clock recovery input
86108B-PTB	Integrated precision timebase
86108B-JSA	Jitter spectrum analysis and software clock recovery emulation
86108B-A23	Two adapters, 2.4 to 3.5 mm (f)
86108B-CA2	Matched cable pair, 2.4 to 2.4 mm, 24 inch
86108B-CA3	Matched cable pair, 3.5 to 3.5 mm, 18 inch
86108B-DC2	Two DC blocks, 2.4 mm, 16 V, 50 kHz to 50 GHz
86108B-DC3	Two DC blocks, 3.5 mm, 16 V, 50 kHz to 26.5 GHz
86108B-PT2	Two 2.4 mm phase trimmers for external skew adjustment
86108B-PT3	Two 3.5 mm phase trimmers for external skew adjustment

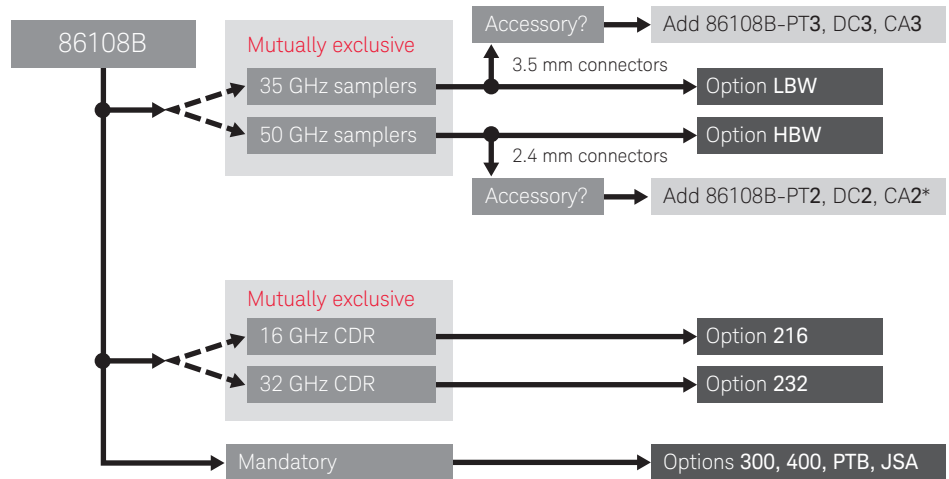

\* Optionally also two 11901C 2.4 (m) to 3.5 (f) adaptors (sold separately)





## 86112A 20 GHz Dual Channel Electrical Module

Provides two measurement channels with user-selectable bandwidth.

Model/option number	Description
86112A	20 GHz dual channel electrical module

- > 12.4 or > 20 GHz bandwidth
- Single-ended or differential operation
- Compatible with 86100A/B DCA, 86100C DCA-J and 86100D DCA-X mainframes



## 86115D 20/34 GHz Multi-Port 86100 Plug-in Module for High-Volume/Parallel Optical Transceiver Test

- 20 or 34 GHz bandwidth, 750 to 1650 nm, for 8 to 28 Gb/s transceiver test
- Two major configurations:
  - Two optical channels for 8.5 to 14.025 Gb/s
  - Two optical channels for 25.78 to 28.05 Gb/s
- Compatible with 86100C DCA-J and 86100D DCA-X mainframes

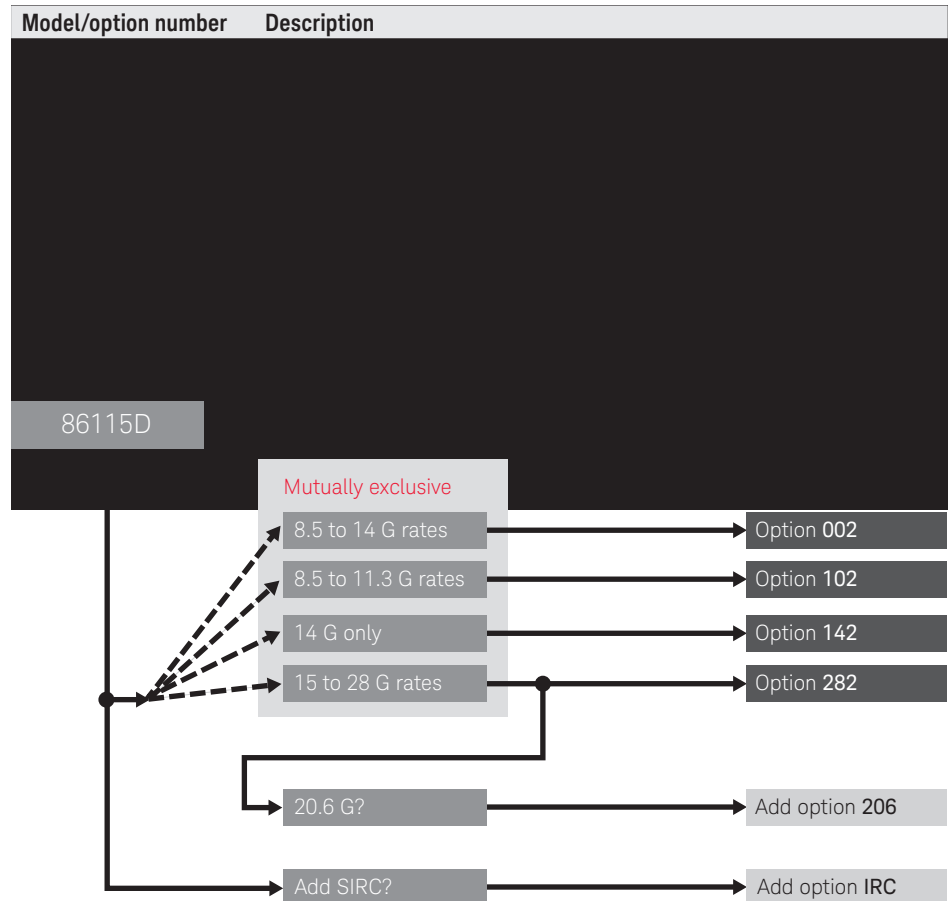

1. Options 168 and 206 require Option 282.



## 86116C 40 to 65 GHz Optical and 80 GHz Electrical Plug-in Modules

### 86116C-041

- 70 GHz characteristic optical bandwidth displays up to 107 Gb/s NRZ (with option IRC)
- Reference receiver for 39.81, 41.25 and 43.02 Gb/s NRZ

### 86116C-025

- 45 GHz characteristic optical bandwidth displays up to 40 Gb/s NRZ
- Reference receiver for 17, 25.8, and 27.7 Gb/s NRZ

### Both options

- 93 GHz characteristic electrical bandwidth
- 1.85 mm male input
- Compatible with 86100C DCA-J and 86100D DCA-X Mainframes



Model/option number	Description
86116C	40 to 65 GHz optical/80 GHz electrical sampling module, 1300 to 1620 nm
86116C-025	40 GHz opt./80 GHz elec., 17.0/25.8/27.7 Gb/s reference receiver
86116C-041	65 GHz opt./80 GHz elec., 39.8/41.25/43.0 Gb/s reference receiver
86116C-201	15 cm 1.85 mm semi rigid cable <sup>1</sup>
86105C-IRC	System impulse response correction calibration

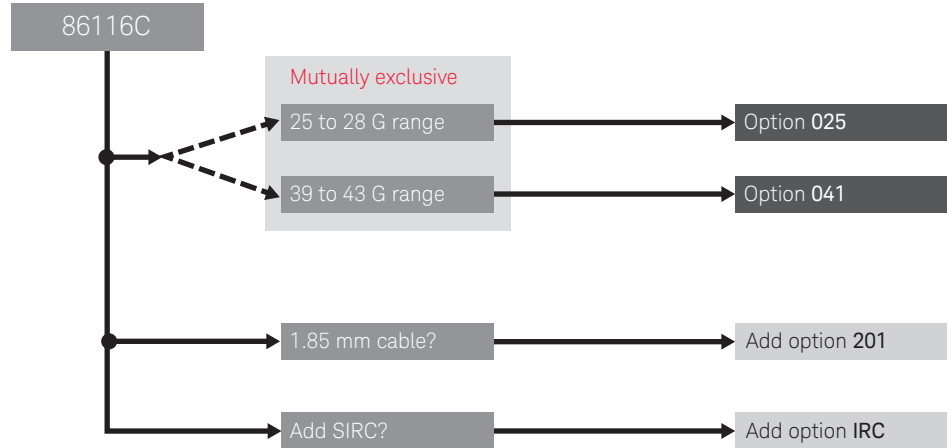

1. Use N5520B 1.85 mm (f-f) connector saver to connect the cable to the 86116C electrical channel.



## 86118A 70 GHz Dual Remote Sampling Head Module

With over 70 GHz of electrical bandwidth, the 86118A provides one of the fastest channel performance available today. A well behaved frequency response minimizes attenuation of the signal and maintains fast edge speeds. In order to measure differential signals option 86118A-H01 is highly recommended.

- Two 70 GHz electrical remote heads with 1.85 mm female connectors
- Compatible with 86100C DCA-J and 86100D DCA-X mainframes



Model/option number	Description
86118A	70 GHz dual electrical module with remote sampling head module (2 m cable)
86118A-101	Adds two 1.85 mm M/M connector savers/adapters
86118A-102	Adds one 1.85 mm M/F and one M/M connector saver/adaptor
86118A-103	Adds two 1.85 mm M/F connector savers/adapters
86118A-201	15 cm 1.85 mm rigid cable
86118A-H01	Less than 40 ps skew between the 2 channels and alignment capability within 100 ps
86118A-H11	Provides amplitude data up to 110 GHz

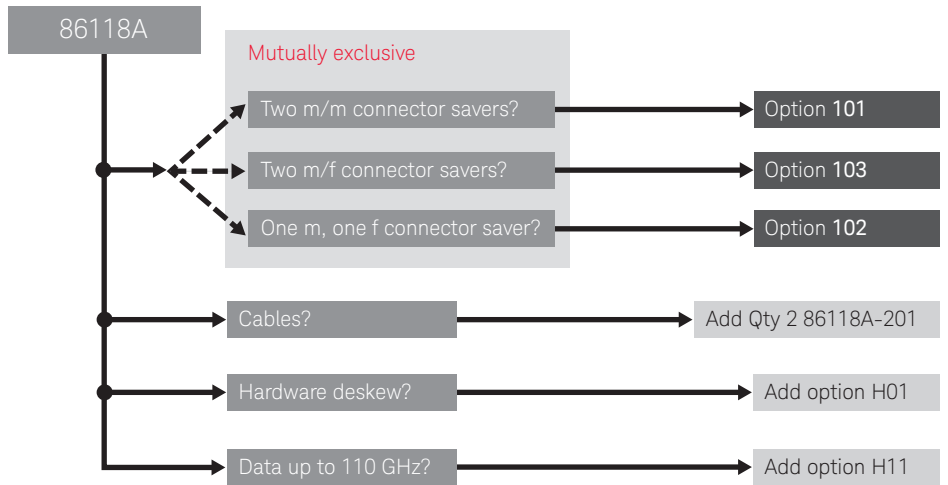

86118A heads have 1.85 mm female input connectors.



## N1045A 60 GHz 2/4 Port Electrical Remote Sampling Head Module

The N1045A 60 GHz remote sampling head module is engineered to provide superior measurement accuracy with the highest throughput for testing multi-lane electrical designs. The remote head design allows the high-bandwidth sampler to be located very near the device under test which minimizes loss due to cabling.

- 60 GHz bandwidth (65 GHz typical)
- Independent skew control on each sampler
- 2 to 16 electrical channels per mainframe
- Simultaneous data acquisition on all channels
- Compatible with 86100D DCA-X mainframes



Model/option number	Description
N1045A	60 GHz 2/4 port electrical remote sampling head module
N1045A-02F	2 channel remote head, 1.85 mm, female
N1045A-02M	2 channel remote head, 1.85 mm, male
N1045A-04F	4 channel remote head, 1.85 mm, female
N1045A-04M	4 channel remote head, 1.85 mm, male
N1045A-LOJ	Ultra-low jitter performance
N1027A-45A	N1045A accessory kit <sup>1</sup>

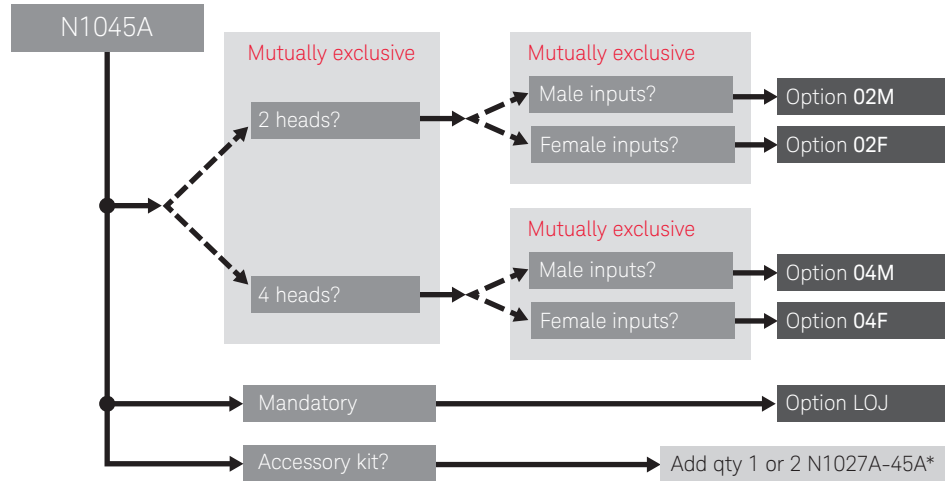

\* Each N1027A-45A accessory kit supports one differential channel (two heads).

See Technical Overview on [www.keysight.com/find/N1027A](http://www.keysight.com/find/N1027A)



## N1046A 75/85/>100 GHz 1/2/4 Port Electrical Remote Sampling Head Module

The N1046A is a group of remote sampling head modules designed for the fastest oscilloscope applications. The “soft roll-off” of their frequency response can capture wideband digital signals such as NRZ or PAM4, as well as narrowband.

- 75 GHz, 85 GHz or > 100 GHz maximum available bandwidth (selectable option, upgradable)
- 1, 2 or 4 channels per module
- 1 to 4 modules per mainframe
- Independent skew control on each sampler
- Simultaneous data acquisition on all channels
- User-selectable bandwidth settings starting at 60 GHz
- Electrical inputs: 1 mm female
- Compatible with 86100D DCA-X mainframes



Model/option number	Description
N1046A	100 GHz 1/2/4 port electrical remote sampling head module
N1046A-71F	1 channel, 75 GHz remote head, 1 mm, female
N1046A-81F	1 channel, 85 GHz remote head, 1 mm, female
N1046A-11F	1 channel, 100 GHz remote head, 1 mm, female
N1046A-72F	2 channel, 75 GHz remote head, 1 mm, female
N1046A-82F	2 channel, 85 GHz remote head, 1 mm, female
N1046A-12F	2 channel, 100 GHz remote head, 1 mm, female
N1046A-74F	4 channel, 75 GHz remote head, 1 mm, female
N1046A-84F	4 channel, 85 GHz remote head, 1 mm, female
N1046A-14F	4 channel, 100 GHz remote head, 1 mm, female

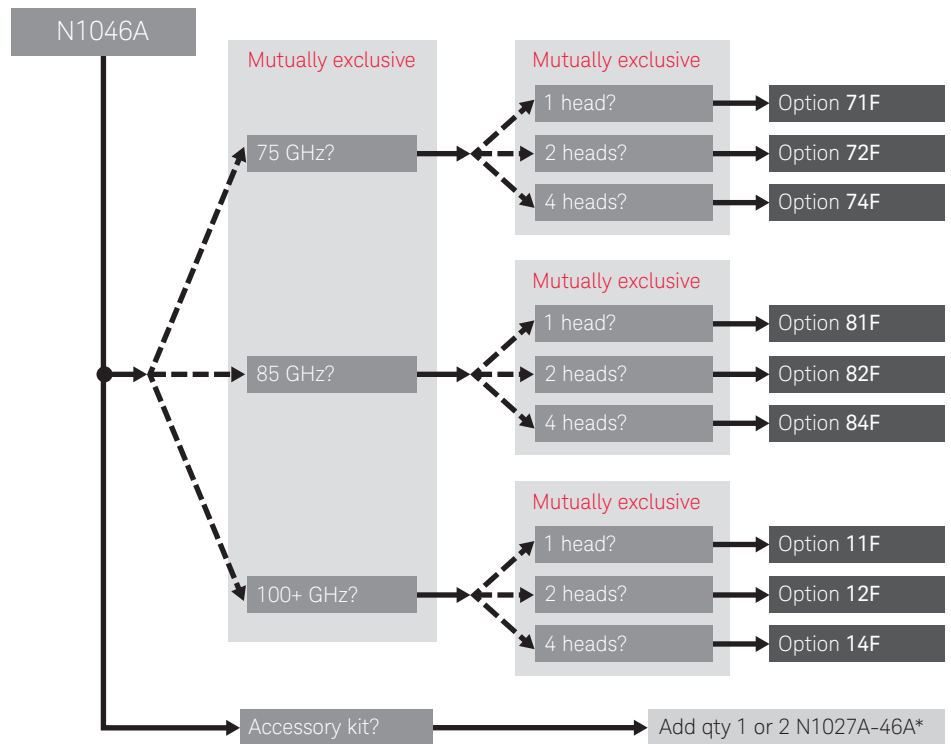

\* Each N1027A-46A accessory kit supports one differential channels (two heads).



## N1055A 35/50 GHz 2/4 Port TDR/TDT Remote Sampling Head Module

The Keysight N1055A 35/50-GHz (8-ps) time-domain reflectometry (TDR) and time-domain transmission (TDT) module for the Keysight 86100D DCA-X platform provides fast, accurate impedance and S-parameter measurements on high-speed designs that have up to 16 ports.

- Dual or quad remote heads with either 35 or 50 GHz bandwidth
- Edge speed (10 to 90%, typical): 18 ps (35 GHz) or 8 ps (50 GHz)
- Integrated diode limiters for ESD/EOS protection
- Simultaneous data acquisition on all channels
- Compatible with 86100D DCA-X mainframes



Model/option number	Description
N1055A	35/50 GHz, 2/4 port, electrical remote sampling head module with TDR/TDT
N1055A-32F	35 GHz BW, 2 channels, 2.92 mm, female
N1055A-32M	35 GHz BW, 2 channels, 2.92 mm, male
N1055A-34F	35 GHz BW, 4 channels, 2.92 mm, female
N1055A-34M	35 GHz BW, 4 channels, 2.92 mm, male
N1055A-52F	50 GHz BW, 2 channels, 1.85 mm, female
N1055A-52M	50 GHz BW, 2 channels, 1.85 mm, male
N1055A-54F	50 GHz BW, 4 channels, 1.85 mm, female
N1055A-54M	50 GHz BW, 4 channels, 1.85 mm, male
N1055A-FS1	Fast sampling
N1027A-x4x <sup>2</sup>	N1055A accessory kit <sup>1</sup>
N4694A-HFF	ECal module DC-67 GHz, 1.85 mm female
N4694A-HMF	ECal module DC-67 GHz, 1.85 mm male/female
N4694A-HMM	ECal module DC-67 GHz, 1.85 mm male

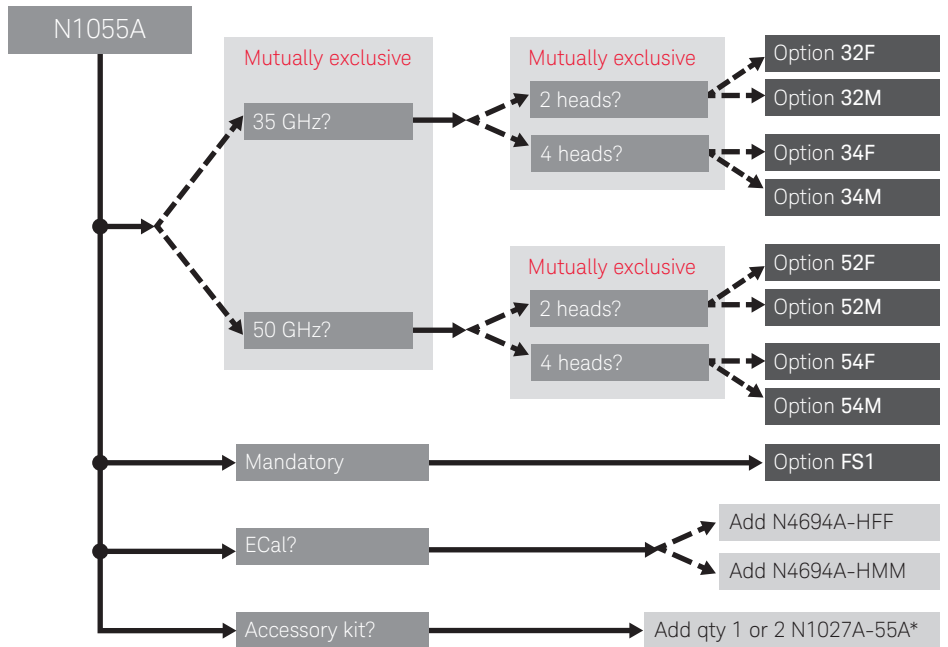

\* Each N1027A-54A accessory kit supports two differential channels (four heads).

- N1055A-xxx and N4694A-xxx: Last option character indicates male (M) or female (F) inputs.
- N4694A-HMM directly connects to two N1055A-5xM heads. N4694A-HFF directly connects to two N1055A-5xM heads.
- Add qty 2 11901D 2.4 mm female to 3.5 mm male adapters to connect the N4694A-HMM to two N1055A-3xF heads.
- Add qty 2 11901B 2.4 mm female to 3.5 mm female adapters to connect the N4694A-HMM to two N1055A-3xM heads.

1. See Technical Overview on [www.keysight.com/find/N1027A](http://www.keysight.com/find/N1027A).  
 2. The first and last character of the option code for the TDR accessory kit must match the N1055A configuration (e.g., use the N1027A-54F accessory kit for the N1055A-52F and N1055A-54F TDR/TDT modules, and the N1027A-34M for the N1055A-32M and N1055A-34M).



## N1076A Electrical Clock Recovery

- Provides compliant clock recovery capabilities for electrical non-return-to-zero (NRZ) and pulse amplitude modulation 4-level (PAM4) signals
- Continuous unbanded tuning from 50 MBd to 32 GBd
- Adjustable clock recovery loop bandwidth (to 20 MHz) and peaking for “Golden PLL” performance
- Supports NRZ and PAM4 signals
- Ultra-low residual random jitter < 100 fs RMS
- Jitter Spectrum Analysis (JSA) and “ideal” clock recovery emulation capability
- Phase noise analysis of clock or data signals using 86100DU-400 PLL software
- Controlled by N1010A FlexDCA application (free download) or 86100D DCA-X mainframes
- Compatible with all 86100<sup>1</sup> DCA mainframes and N109X DCA-M<sup>1</sup>

Model/option number	Description
N1076A	Electrical clock recovery
N1076A-216	Supported input rates: 50 MBd to 16 GBd
N1076A-232	Supported input rates: 50 MBd to 32 GBd
N1076A-JSA	Jitter spectrum analysis and clock recovery emulation
N1076A-CR1	Clock recovery phase matching kit for N1076A
N1076A-COC	Certificate of calibration
N1076A-UK6	Commercial calibration certificate with test data
N1076A-1CM	Single instrument rack mount kit
N1076A-1CN	Dual instrument side-by-side rack mount kit

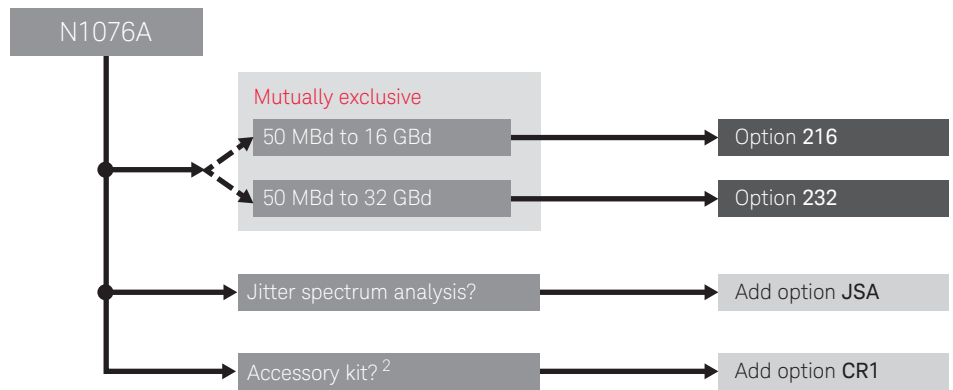

1. 86100A/B/C and N109X require N1010A FlexDCA running on an external PC.
2. Accessory kit provides electrical cables and high-bandwidth pickoff tees that minimize clock-to-data delays when the N1076A is paired with an 86100D-PTB mainframe equipped with a remote head module such as the N1045A/N1055A. For example, matching clock-to-data delays ensure accurate jitter analysis performance.





## N1076B Electrical Clock Recovery

- Provides compliant clock recovery capabilities for electrical non-return-to-zero (NRZ) and pulse amplitude modulation 4-level (PAM4) signals
- Continuous unbanded tuning from 125 MBd to 56 GBd (PAM4)/64 GBd (NRZ)
- Adjustable clock recovery loop bandwidth (to 20 MHz) and peaking for “Golden PLL” performance
- Internal and external equalizers to recover clock from closed eyes
- Ultra-low residual random jitter < 100 fs RMS
- Jitter Spectrum Analysis (JSA) and “ideal” clock recovery emulation capability
- Phase noise analysis of clock or data signals using 86100DU-400 PLL software
- Controlled by N1010A FlexDCA application (free download) or 86100D DCA-X mainframes
- Compatible with all 86100 DCA mainframes <sup>1</sup> and N109X DCA-MS <sup>1</sup>



Model/option number	Description
N1076B	Electrical clock recovery
N1076B-216	Supported input rates: 125 MBd to 16 GBd
N1076B-232	Supported input rates: 125 MBd to 32 GBd
N1076B-264	Supported input rates: 125 MBd to 64 GBd
N1076B-EVA	Equalizer, integrated, variable
N1076B-EQ3	Equalizer, 3 dB, 2.92 mm (m/f), up to 32GBd
N1076B-EQ6	Equalizer, 6 dB, 2.92 mm (m/f), up to 32GBd
N1076B-EQ9	Equalizer, 9d B, 2.92 mm (m/f), up to 32GBd
N1076B-2P1	Microwave pick-off tee 1.0 mm connectors, matched pair
N1076B-2P8	Microwave pick-off tee 1.85 mm connectors, matched pair
N1076B-2P2	Microwave pick-off tee 2.4mm connectors, matched pair
N1076B-2P3	Microwave pick-off tee 2.92 mm connectors, matched pair
N1076B-CR1	Clock recovery phase matching kit for N1076B electrical CR <sup>2</sup>
N1076B-JSA	Jitter spectrum analysis and clock recovery emulation
N1076B-COC	Certificate of calibration
N1076B-UK6	Commercial calibration certificate with test data
N1076B-1CM	Single instrument rack mount kit
N1076B-1CN	Dual instrument side-by-side rack mount kit

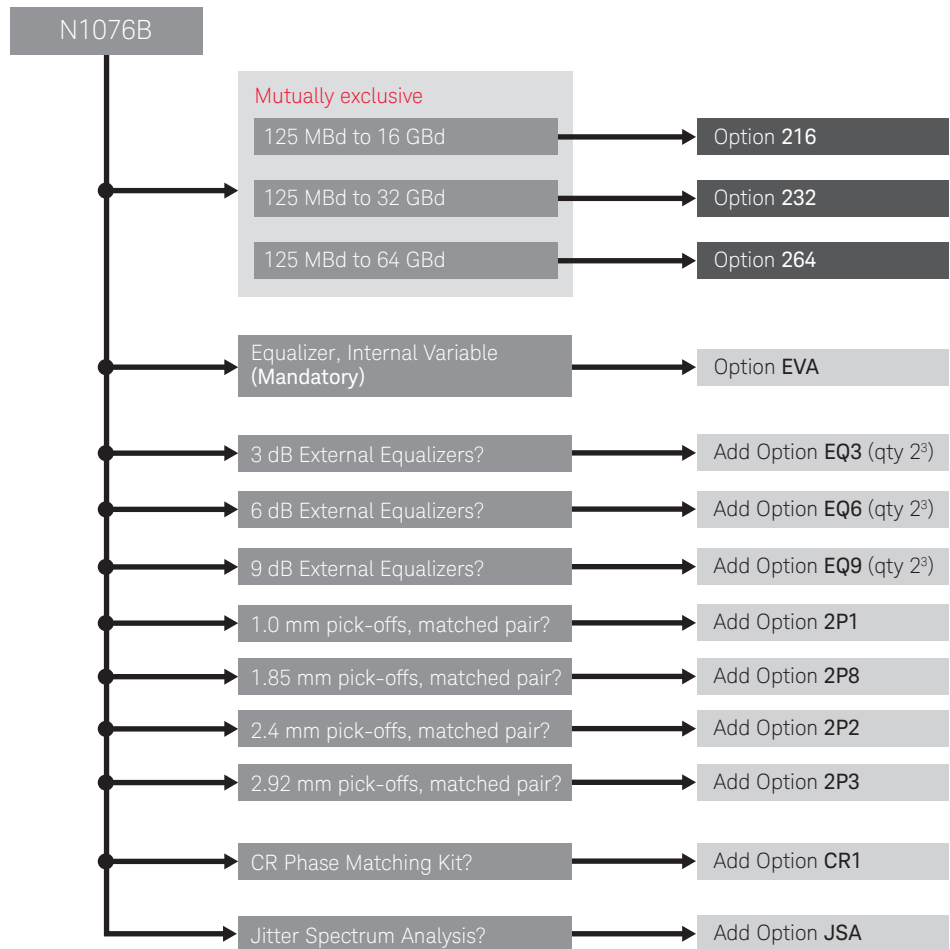

1. 86100A/B/C and N109X require N1010A FlexDCA running on an external PC.
2. Accessory kit provides electrical cables and high-bandwidth pickoff tees that minimize clock-to-data delays when the N1076B is paired with a mainframe that has an internal precision timebase and is equipped with a remote head module such as the N1045A/N1046A/N1055A. Matching clock-to-data delays ensure accurate jitter analysis performance.
3. For differential signals (single-ended need only quantity 1).



## N1077A Optical/Electrical Clock Recovery

- Provides compliant clock recovery capabilities for single- and multimode optical as well as electrical signals
- Works with non-return-to-zero (NRZ) and pulse amplitude modulation 4-level (PAM4) modulation
- Continuous unbanded tuning from 50 MBd to 32 GBd
- 830 to 1600 nm, single-mode and multimode
- Integrated amplified optical-to-electrical (O/E) (high sensitivity)
- Adjustable clock recovery loop bandwidth (to 20 MHz) and peaking for “Golden PLL” performance
- Supports NRZ and PAM4 signals
- Ultra-low residual random jitter < 100 fs RMS
- Integrated single-mode (SM) and multimode (MM) splitters (optional)
- Jitter Spectrum Analysis (JSA) and “ideal” clock recovery emulation capability (optional)
- Supports phase noise analysis of clock or data signals using 86100DU-400 PLL software
- Controlled by N1010A FlexDCA application (free download) or 86100D DCA-X mainframes
- Compatible with all 86100<sup>1</sup> DCA mainframes and N109X DCA-M<sup>1</sup>

Model/option number	Description
N1077A	Optical/electrical clock recovery
N1077A-216	Supported input rates: 50 MBd to 16 GBd
N1077A-232	Supported input rates: 50 MBd to 32 GBd
N1077A-JSA	Jitter spectrum analysis and clock recovery emulation
N1077A-SMS	Internal single-mode (9/125 μm) and multimode (50/125 μm) splitter
N1077A-SXT	External splitter (supplied by user)
N1077A-CR1	Clock recovery phase matching kit for N1077A
N1077A-COC	Certificate of calibration
N1077A-UK6	Commercial calibration certificate with test data
N1077A-1CM	Single instrument rack mount kit
N1077A-1CN	Dual instrument side-by-side rack mount kit

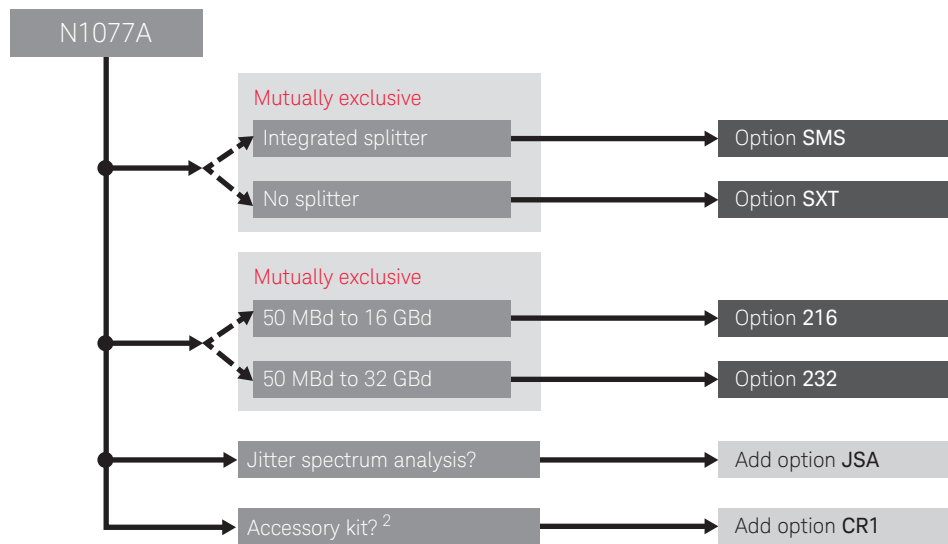

1. 86100A/B/C require N1010A FlexDCA running on an external PC.
2. Accessory kit provides optical cables that minimize clock-to-data delays when the N1077A is paired with an N1092X DCA-M or 86100D-PTB mainframe equipped with an optical DCA plug-in module such as the 86105D. For example, matching clock-to-data delays ensure accurate jitter analysis performance.



## N1078A Optical/Electrical Clock Recovery

- Provides compliant clock recovery capabilities for single-mode optical as well as electrical signals
- Works with non-return-to-zero (NRZ) and pulse amplitude modulation 4-level (PAM4) modulation
- Continuous unbanded tuning from 125 MBd to 56 GBd (PAM4) / 64 GBd (NRZ)
- Adjustable clock recovery loop bandwidth (to 20 MHz) and peaking for “Golden PLL” performance
- Internal and external equalizers to recover clock from closed eyes
- Ultra-low residual random jitter < 100 fs RMS
- Jitter Spectrum Analysis (JSA) and “ideal” clock recovery emulation capability
- Phase noise analysis of clock or data signals using 86100DU-400 PLL software
- Controlled by N1010A FlexDCA application (free download) or 86100D DCA-X mainframes
- Compatible with all 86100 DCA mainframes <sup>1</sup> and N109X DCA-Ms <sup>1</sup>

Model/option number	Description
N1078A	Optical/Electrical clock recovery
N1078A-216	Supported input rates: 125 MBd to 16 GBd
N1078A-232	Supported input rates: 125 MBd to 32 GBd
N1078A-264	Supported input rates: 125 MBd to 64 GBd
N1078A-S50	S50 Internal single-mode (9/125 μm) splitter
N1078A-SXT	SXT External splitter (supplied by user)
N1078A-EQ3	Equalizer, 3 dB, 2.92 mm (m/f), up to 32 GBd
N1078A-EQ6	Equalizer, 6 dB, 2.92 mm (m/f), up to 32 GBd
N1078A-EQ9	Equalizer, 9 dB, 2.92 mm (m/f), up to 32 GBd
N1078A-EVA	Equalizer, integrated, variable
N1078A-JSA	Jitter spectrum analysis and clock recovery emulation
N1078A-CR1	Clock recovery phase matching kit for N1078A Optical CR
N1078A-COC	Certificate of calibration
N1078A-UK6	Commercial calibration certificate with test data
N1078A-1CM	Single instrument rack mount kit
N1078A-1CN	Dual instrument side-by-side rack mount kit

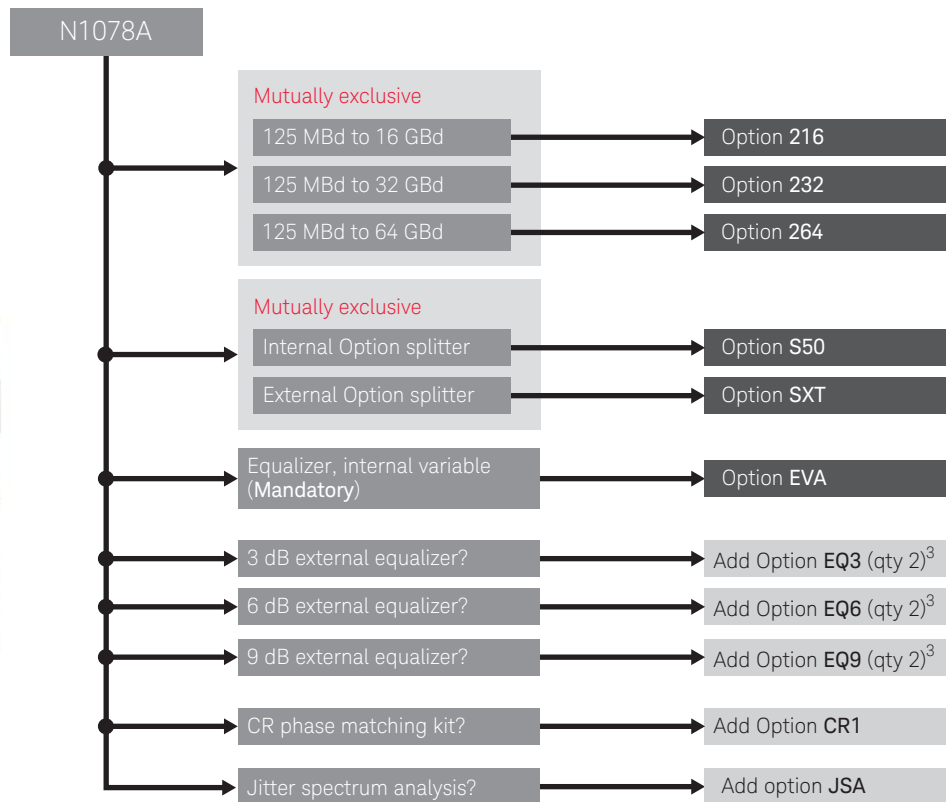

1. 86100A/B/C and N109X require N1010A FlexDCA running on an external PC.
2. Accessory kit provides single-mode patchcords that minimize clock-to-data delays when the N1078A is paired with a mainframe that has an internal precision timebase. Use the N1027A-76B kit for electrical applications. Matching clock-to-data delays ensure accurate jitter analysis performance.
3. For differential signals (single-ended need only quantity 1).



## N1090A DCA-M Sampling Oscilloscope

- High accuracy, low cost solution for optical eye diagram analysis
- 750 to 1650 nm, single- and multimode
- Controlled by N1010A FlexDCA application (free download) or 86100D DCA-X mainframes

Model/option number	Description
N1090A-140	Reference receiver filters for 1.244/1.25/1.229 Gb/s
N1090A-160	Reference receiver filters for 2.458/2.488/2.5 Gb/s
N1090A-180	Reference receiver filters for 3.072/3.125 Gb/s
N1090A-200	Reference receiver filters for 8.5/9.95/10.3/10.5/10.66/10.71/11.1/11.3 Gb/s
N1090A-204	Reference receiver filters for 8.5/9.95/10.3/10.5 Gb/s
N1090A-EEC	Enable electrical channel
N1090A-PLK	Pattern lock trigger hardware
N1090A-IRC	Impulse response correction <sup>1</sup>
N1090A-COC	Certificate of Calibration
N1090A-UK6	Commercial calibration certificate with test data
N1090A-1CM	Single instrument rack mount kit
N1090A-1CN	Dual instrument side by side rack mount kit

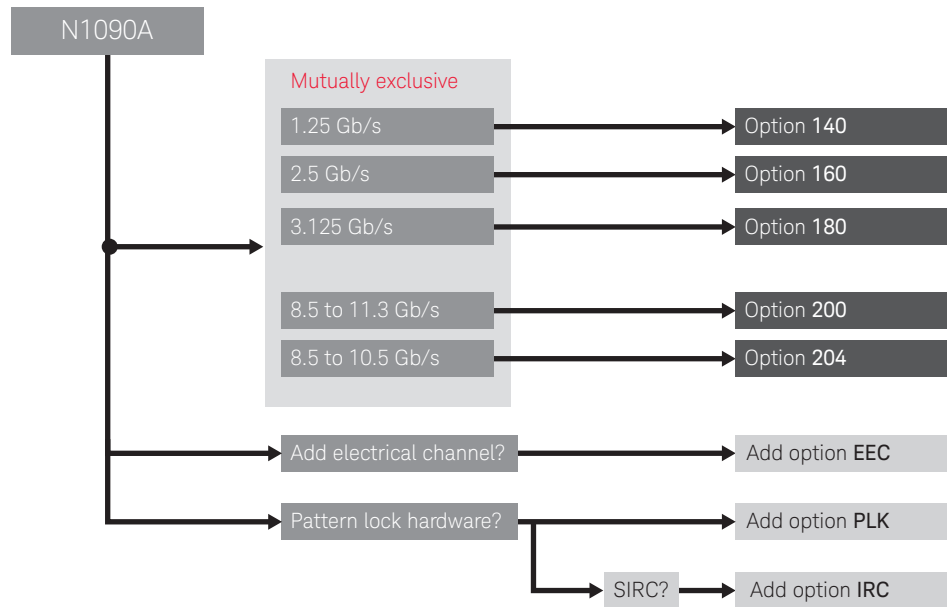

1. Requires option PLK.



## N1092A/B/C/D/E 1/2/3/4 Channel Optical DCA-M Sampling Oscilloscope

- High accuracy, low cost solution for optical eye, waveform and jitter analysis
- 830 to 1600 nm, single- and multimode
- Controlled by N1010A FlexDCA application (free download) or 86100D DCA-X mainframes



Model/option number	Description
N1092A	Single optical channel oscilloscope
N1092B	Dual optical channel oscilloscope
N1092C	Single optical, dual electrical channel oscilloscope
N1092D	Quad optical channel oscilloscope
N1092E	Dual optical, dual electrical channel oscilloscope
N1092x-30A	30 GHz amplified (mandatory)
N1092x-280	25.781, 27.739, 27.952, 28.050 Gbaud filters (mandatory)
N1092x-LOJ	Low jitter timebase
N1092x-STB	Standard timebase
N1092x-PLK	Pattern lock capability
N1092x-FS1	Fast sampling rate
N1092x-200	Enhanced jitter analysis software, fixed perpetual license
N1092x-201	Advanced waveform analysis software, fixed perpetual license
N1092x-300	Advanced amplitude analysis/Rin/Q-Factor, fixed perpetual license
N1092x-401	Advanced eye analysis software, fixed perpetual license
N1092x-500	Productivity package, fixed perpetual license
N1092x-9FP	PAM-N analysis SW, fixed perpetual license
N1092x-TFP	IEEE TDECQ analysis, fixed perpetual license
N1092x-PLK	Pattern lock trigger hardware
N1092x-IRC	Impulse response correction
N1092x-EFP	FlexEye Independent Channel Acquisition and Control
N1092x-SIM	InfiniiSim-DCA waveform transformation SW, fixed perpetual license
N1092x-IRC	Impulse response correction
N1092x-168	Additional 25.78 Gb/s TDEC filter (requires Option 500)
N1092x-206	Additional 20.625 Gb/s filter
N1092x-COC	Certificate of Calibration
N1092x-UK6	Commercial calibration certificate with test data
N1092x-1CM	Single instrument rack mount kit
N1092x-1CN	Dual instrument side by side rack mount kit



## N1092A/B/C/D/E 1/2/3/4 Channel Optical DCA-M Sampling Oscilloscope (Continued)

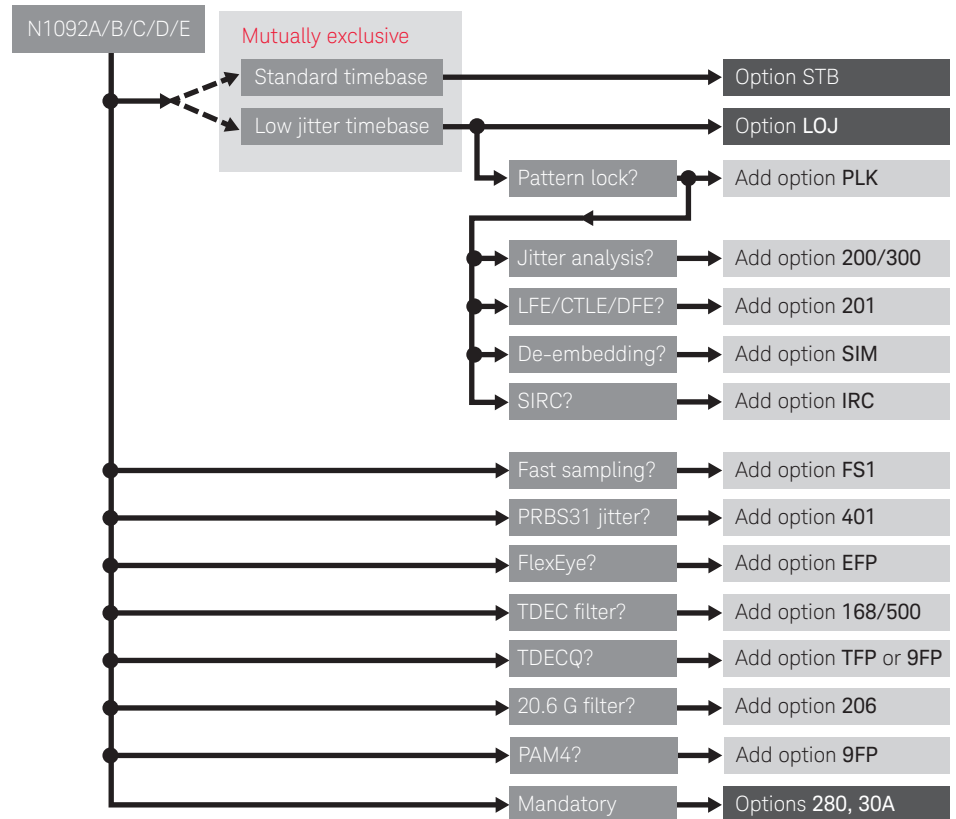

- Options 200 and 300 must be ordered together.
- Options 168 requires Option 500.
- Options 280 and 30A are mandatory for all units.
- To measure TDECQ on optical 26 Gbaud or 53 Gbaud PAM4 signals per IEEE. 802.3bs, the N1092X must have at least options LOJ, PLK, IRC and either 9FP or TFP.



## N1094A/B 2/4 Channel Electrical DCA-M Oscilloscope

- High-accuracy, low-cost solution for electrical eye, waveform and jitter analysis
- 20/33 GHz and 20/33/40/50 GHz bandwidth settings support OIF and Ethernet standards
- Controlled by N1010A FlexDCA application (free download) or 86100D DCA-X mainframes

Model/option number	Description
N1094A	Dual electrical channel oscilloscope
N1094B	Quad electrical channel oscilloscope
N1094x-030	20 and 30 GHz bandwidth settings
N1094x-050	20, 33, 40 and 50 GHz bandwidth settings
N1094x-LOJ	Low jitter timebase
N1094x-STB	Standard timebase
N1094x-PLK	Pattern lock capability
N1094x-FS1	Fast sampling rate
N1094x-200	Enhanced jitter analysis software, fixed perpetual license
N1094x-201	Advanced waveform analysis software, fixed perpetual license
N1094x-300	Advanced amplitude analysis/Rin/Q-Factor, fixed perpetual license
N1094x-401	Advanced eye analysis software, fixed perpetual license
N1094x-500	Productivity package, fixed perpetual license
N1094x-9FP	PAM-N analysis software, fixed perpetual license
N1094x-TFP	IEEE TDECQ analysis, fixed perpetual license
N1094x-PLK	Pattern lock trigger hardware
N1094x-EFP	FlexEye independent channel acquisition and control
N1094x-SIM	InfiniiSim-DCA waveform transformation software, fixed perpetual license
N1094x-COC	Certificate of calibration
N1094x-UK6	Commercial calibration certificate with test data
N1094x-1CM	Single instrument rack mount kit
N1094x-1CN	Dual instrument side-by-side rack mount kit

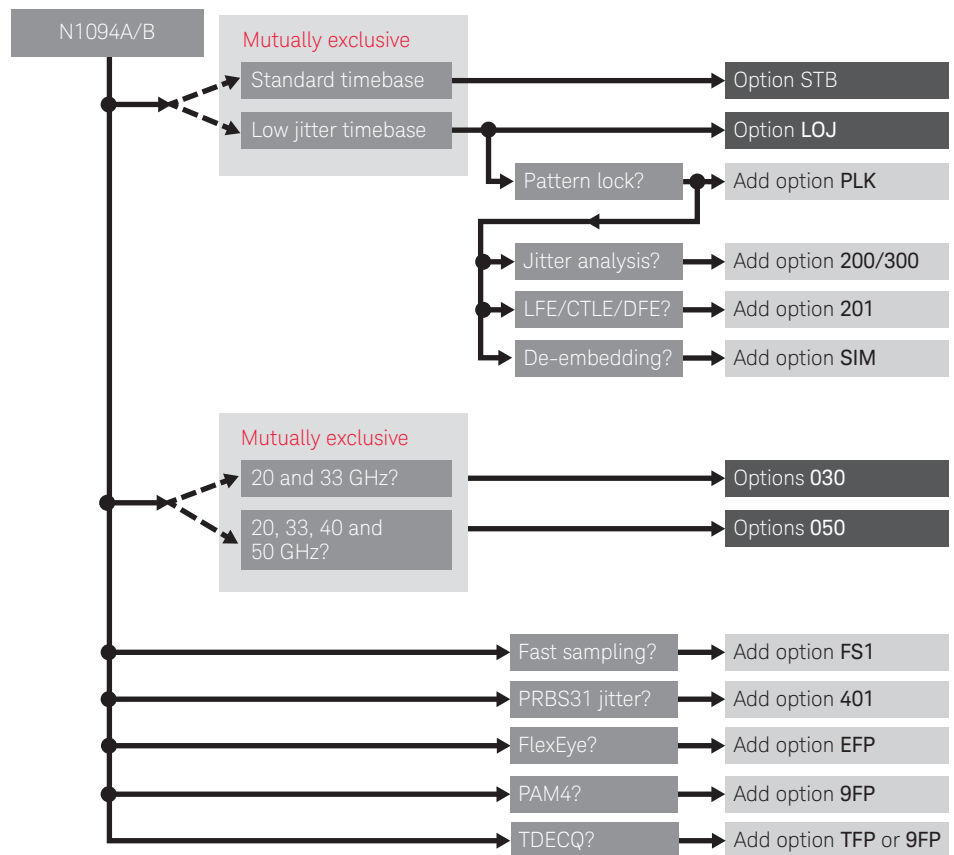

Options 200 and 300 must be ordered together.



## N1027A Oscilloscope Accessories for DCA Family

N1027A is a collection of accessories for mainframes and modules in the 86100 family of Digital Communication Analyzers (DCAs). The accessories can be grouped into:

- Kits including multiple parts for specific applications (e.g., N1027A-45A for the N1045A 60 GHz Electrical Remote Sampling Heads)
- Individual components needed for measurements (e.g., N1027A-PT2/PT3 phase trimmers to adjust skew between electrical channels)
- Items for protection and storage (e.g., N1027A-1MC storage case for mini-modules with remote heads)

For further details, download the N1027A Technical Overview from [www.keysight.com/find/N1027A](http://www.keysight.com/find/N1027A)





## Appendix: Dependencies of Options and Software Licenses

The following options require pattern lock capability in the hardware (e.g., Option ETR on the DCA-X or Option PLK on the DCA-M):

Model/option number	Description
200	Enhanced jitter analysis (must be ordered together with Option 300)
201	Advanced waveform analysis (includes LFE/CTLE/DFE)
300	Advanced amplitude analysis/RIN/Q-Factor
SIM	Waveform transformation (includes signal de-embedding)
IRC	System impulse response correction data

Most DCA applications also require software licenses:

Model/option number	Description
N1012A	200/300, 201 (required), 401, SIM (optional)
N1014A	200/300, 201 (required), 401, SIM (optional)
N1081/2/3/4A	200/300, 201 (required), 202, 401, SIM (optional)
N1085A	200/300, 201, 9FP (required), 202, 401, SIM (optional)



## Appendix: DCA Input Connectors

Product	Probe power	3.5 mm	2.4 mm	2.92 mm	1.85 mm	1.00 mm	Optical	Comment
54754A	Yes	f/f CS						
83496B	No	f/f CS					FC/PC nut	
86100C/D	No	f/f CS						Trigger input
86105C	No	f/f CS					FC/PC nut	
86105D	No	f/f CS	f/f CS				FC/PC nut	2.4 mm for option 281
86107A	No	f/f CS	f/f CS					2.4 mm only on 40 GHz input
86108A	Yes	f/f CS						
86108B	Yes	f/f CS	f/f CS					2.4 mm only on 50 GHz input
86112A	Yes	f/f CS						
86115D	No						FC/PC nut	
86116C	No				m fixed		FC/PC nut	
86117A	No		f/f CS					
86118A	No				f fixed			
N1045A-xxF	No				f fixed			
N1045A-xxM	No				m fixed			
N1046A-xxF						f fixed		Includes 1.0/1.85 mm adapter(s)
N1055A-3xF	No			f fixed				
N1055A-3xM	No			m fixed				
N1055A-5xF	No				f fixed			
N1055A-5xM	No				m fixed			
N1076A/76B	No			f fixed				
N1077A/78B	No			f fixed			FC/PC	
N1090A	No	f SMA					FC/PC	
N2092A/B/D	No						FC/PC	
N1092C/E	No		f/f CS				FC/PC	
N1094A/B	No		f/f CS					Option 030 includes 2.4/2.92 mm adapters

f/f CS	Female/female connector saver (bulkhead is male, customer can remove connector saver)
m/m CS	Male/male connector saver (bulkhead is female, customer can remove connector saver)
f fixed	Female fixed interface
m fixed	Male fixed interface
FC/PC nut	86100FI straight FC/PC interface (customer can exchange it with interfaces, see Optical Interfaces in the Technical Overview on <a href="http://www.keysight.com/find/N1027A">www.keysight.com/find/N1027A</a> )
f SMA	Female SMA input (fixed)
FC/PC	Cleanable FC/PC adapter
DCA-M clock	Use 2.92 or 3.5 mm cables to provide clocks to the N1090X, N1092X and N1094X DCA-M oscilloscopes



## Appendix: RF/Microwave Connectors

### 3.5 mm connector

The 3.5 mm connector was primarily developed at Hewlett Packard—now Keysight Technologies, Inc. with early manufacturing at Amphenol. Its design strategy focused on highly-rugged physical interfaces that would mate with popular SMA dimensions, allowing thousands of repeatable connections. It is mode-free to 34 GHz.

### 2.92 mm connector

The 2.92 mm connector mates with SMA and 3.5 mm connectors and offers mode-free performance to 40 GHz.

### 2.4 mm connector

The 2.4 mm connector was developed by Hewlett Packard, Amphenol, and M/A-COM for use to 50 GHz. This design eliminates the fragility of the SMA and 2.92 mm connectors by increasing the outer wall thickness and strengthening the female fingers. It can mate with SMA, 3.5 mm and 2.92 mm, with the use of precision adapters. The 2.4 mm product is offered in three quality grades: general purpose, instrument, and metrology. General-purpose grade is intended for economy use on components, cables, and microstrip where limited connections and low repeatability is acceptable. Instrument-grade is best suited for measurement applications where repeatability and long life are primary considerations. Metrology-grade is best suited for calibration applications where the highest performance and repeatability are required.

### 1.85 mm connector

The 1.85 mm connector was developed in the mid-1980s by Hewlett Packard (now Keysight Technologies) for mode-free performance to 65 GHz. Hewlett Packard offered their design as public domain in 1988 to encourage standardization of connector types; a few devices are available from various manufacturers for research work. The 1.85 mm connector mates with the 2.4 mm connector and has the same ruggedness. In recent years, the 1.85 mm connector has been optimized to operate mode-free to 67 GHz.

## Appendix: Literature References

Publication title	Publication number
<i>RF and Microwave Test Accessories Catalog 2012/2013 - Catalog</i> ( <a href="http://www.keysight.com/find/mta">www.keysight.com/find/mta</a> )	5990-8661EN
<i>Infiniium DCA-X 86100D Wide-Bandwidth Oscilloscope Mainframe and Modules - Data Sheet</i> ( <a href="http://www.keysight.com/find/dcax">www.keysight.com/find/dcax</a> )	5990-5824EN
<i>Using the Keysight N5477A Sampling Oscilloscope Adapter</i>	N5477-97000
<i>Infiniium DCA-X 86100D Wide-Bandwidth Oscilloscope Mainframe and Modules - Brochure</i>	5990-5822EN
<i>DCA Probes Accessories - Technical Overview</i>	5991-2340EN





[www.axistandard.org](http://www.axistandard.org)

AdvancedTCA® Extensions for Instrumentation and Test (AXIe) is an open standard that extends the AdvancedTCA for general purpose and semiconductor test. The business that became Keysight was a founding member of the AXIe consortium. ATCA®, AdvancedTCA®, and the ATCA logo are registered US trademarks of the PCI Industrial Computer Manufacturers Group.



[www.lxistandard.org](http://www.lxistandard.org)

LAN eXtensions for Instruments puts the power of Ethernet and the Web inside your test systems. The business that became Keysight was a founding member of the LXI consortium.



[www.pxisa.org](http://www.pxisa.org)

PCI eXtensions for Instrumentation (PXI) modular instrumentation delivers a rugged, PC-based high-performance measurement and automation system.

## Download your next insight

Keysight software is downloadable expertise. From first simulation through first customer shipment, we deliver the tools your team needs to accelerate from data to information to actionable insight.

- Electronic design automation (EDA) software
- Application software
- Programming environments
- Productivity software



Learn more at

[www.keysight.com/find/software](http://www.keysight.com/find/software)

Start with a 30-day free trial.

[www.keysight.com/find/free\\_trials](http://www.keysight.com/find/free_trials)



## Evolving Since 1939

Our unique combination of hardware, software, services, and people can help you reach your next breakthrough. We are unlocking the future of technology.

From Hewlett-Packard to Agilent to Keysight.

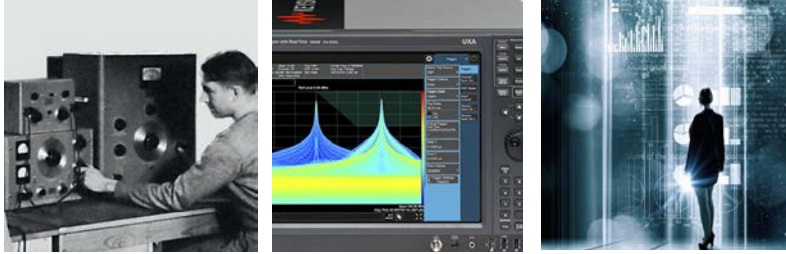

### myKeysight

#### myKeysight

[www.keysight.com/find/mykeysight](http://www.keysight.com/find/mykeysight)

A personalized view into the information most relevant to you.

[http://www.keysight.com/find/emt\\_product\\_registration](http://www.keysight.com/find/emt_product_registration)

Register your products to get up-to-date product information and find warranty information.



#### Keysight Services

[www.keysight.com/find/service](http://www.keysight.com/find/service)

Keysight Services can help from acquisition to renewal across your instrument's lifecycle. Our comprehensive service offerings—one-stop calibration, repair, asset management, technology refresh, consulting, training and more—helps you improve product quality and lower costs.



#### Keysight Assurance Plans

[www.keysight.com/find/AssurancePlans](http://www.keysight.com/find/AssurancePlans)

Up to ten years of protection and no budgetary surprises to ensure your instruments are operating to specification, so you can rely on accurate measurements.

#### Keysight Channel Partners

[www.keysight.com/find/channelpartners](http://www.keysight.com/find/channelpartners)

Get the best of both worlds: Keysight's measurement expertise and product breadth, combined with channel partner convenience.

For more information on Keysight Technologies' products, applications or services, please contact your local Keysight office. The complete list is available at:

[www.keysight.com/find/contactus](http://www.keysight.com/find/contactus)

#### Americas

Canada	(877) 894 4414
Brazil	55 11 3351 7010
Mexico	001 800 254 2440
United States	(800) 829 4444

#### Asia Pacific

Australia	1 800 629 485
China	800 810 0189
Hong Kong	800 938 693
India	1 800 11 2626
Japan	0120 (421) 345
Korea	080 769 0800
Malaysia	1 800 888 848
Singapore	1 800 375 8100
Taiwan	0800 047 866
Other AP Countries	(65) 6375 8100

#### Europe & Middle East

Austria	0800 001122
Belgium	0800 58580
Finland	0800 523252
France	0805 980333
Germany	0800 6270999
Ireland	1800 832700
Israel	1 809 343051
Italy	800 599100
Luxembourg	+32 800 58580
Netherlands	0800 0233200
Russia	8800 5009286
Spain	800 000154
Sweden	0200 882255
Switzerland	0800 805353
	Opt. 1 (DE)
	Opt. 2 (FR)
	Opt. 3 (IT)
United Kingdom	0800 0260637

For other unlisted countries:

[www.keysight.com/find/contactus](http://www.keysight.com/find/contactus)  
(BP-9-7-17)



[www.keysight.com/go/quality](http://www.keysight.com/go/quality)

Keysight Technologies, Inc.  
DEKRA Certified ISO 9001:2015  
Quality Management System

This information is subject to change without notice.

© Keysight Technologies, 2017 - 2018

Published in USA, April 19, 2018

5992-0038EN

[www.keysight.com](http://www.keysight.com)

