

PRODUCT FLYER

# PXI Digital Pattern Instruments

## CONTENTS

[PXI Digital Pattern Instruments](#)

[Detailed View of PXIe-6571 Digital Pattern Instrument](#)

[Key Features](#)

[NI-Digital Pattern Application Programming Interface \(API\)](#)

[Digital Pattern Editor Application Software](#)

[Platform-Based Approach to Test and Measurement](#)

[PXI Instrumentation](#)

[Hardware Services](#)

# PXI Digital Pattern Instruments

PXIe-6570, PXIe-6571



- **Software:** Includes Digital Pattern Editor for pattern development and debugging, API support for LabVIEW and text-based languages, shipping examples, and detailed help files
- 32-channel, 100 MHz vector rate with 39.0625 ps of edge placement resolution
- Digital voltage -2 V to 6 V, and PPMU force voltage -2 V to 7 V
- Up to 200 Mb/s data rate and 160 MHz clock generation
- Combine multiple modules to create digital subsystems with up to 512 channels
- Dedicated source, capture, and history memory resources for up to eight parallel test sites

## Semiconductor ATE-Class Digital on the Open PXI Platform

PXI Digital Pattern Instruments deliver ATE-class digital to the industry-standard PXI platform for testing a broad range of RF and mixed-signal integrated circuits (ICs). The NI PXI platform and NI Semiconductor Test System (STS) are an ideal platform for characterization and production test of RF and mixed-signal ICs from RF front ends and power management ICs to transceivers and Internet of Things systems on chip with built-in connectivity and sensors.

The PXIe-6571 is the highlight of NI's offering for digital production and characterization test of semiconductor devices. For basic digital signals and interfaces, consider PXI Digital I/O Modules or PXI Reconfigurable Digital I/O Modules.

Table 1. PXI Digital Pattern Instruments are built for the testing of semiconductor devices.

	PXIe-6570	PXIe-6571*
Module Width	2 slots	1 slot
Active Load	24 mA	16 mA
Channels	32 per module	
	256 maximum in a synchronized subsystem	512 maximum in a synchronized subsystem
Pin Electronics	Digital: -2 V to +6 V, 32 mA PPMU measure voltage: -2 V to +6 V, 32 mA PPMU force voltage: -2 V to +7 V, 32 mA	
Maximum Vector Rate	100 MHz (10 ns minimum vector period)	
Maximum Data Rate	200 Mb/s	
Maximum Clock Generation	160 MHz**	
Pattern Timing	31 time sets 39.0625 ps edge placement resolution	
Drive Formats	Non-return (NR), return to low (RL), return to high (RH) (100 MHz max), surround by complement (SBC) (50 MHz max)	
Vector Memory Depth	128 M/Channel	
Opcode Support	Flow control, sequencer flags and registers, signal, source and capture, subroutine	
Source and Capture Engines	Broadcast or site-unique Serial or parallel 8 per instrument	
Source and Capture Memory	256 Mbit source memory, 1 MSample capture memory	
Frequency Counters	5 kHz to 200 MHz, per pin	
History RAM	(8,192/N sites) -1 cycles	
SCAN Support	Flattened SCAN patterns, up to 128 M	

\* Note that the PXIe-6571 requires a chassis with 82 W slot cooling capacity, such as the PXIe-1095. For more on PXI power and cooling, see this [white paper](#).

\*\* Clock rates >133 MHz will have a non-50% duty cycle.

# Detailed View of PXIe-6571 Digital Pattern Instrument

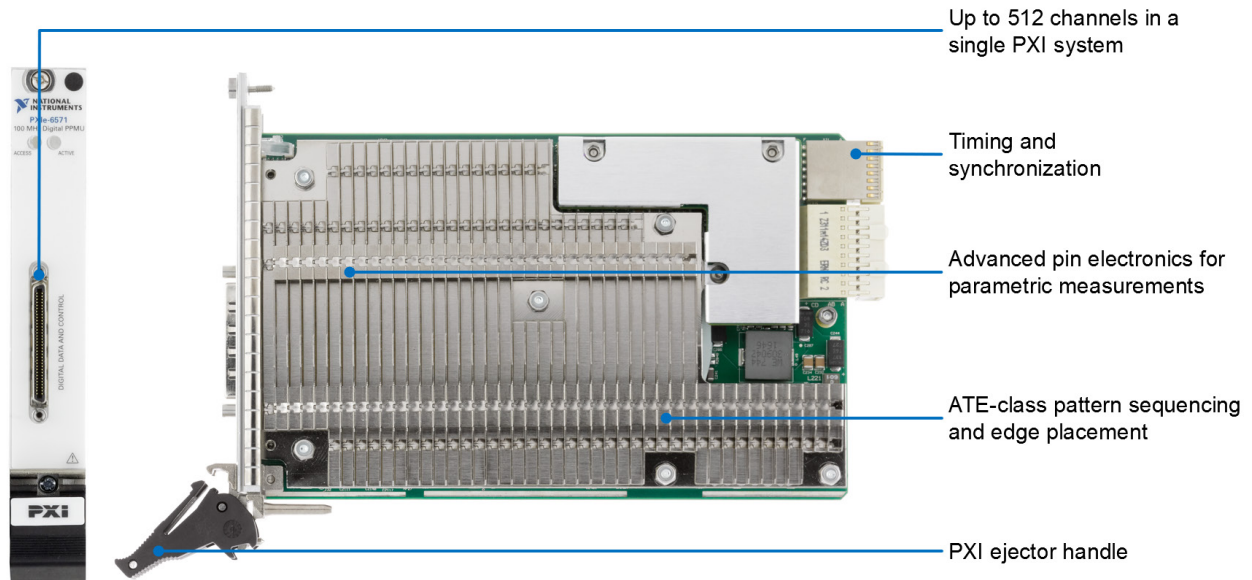

## Key Features

### Hardware Overview

PXI Digital Pattern Instruments have several types of vector and dynamic pattern memory and feature pin electronics. The block diagram in Figure 1 shows the instruments' functional hardware components.

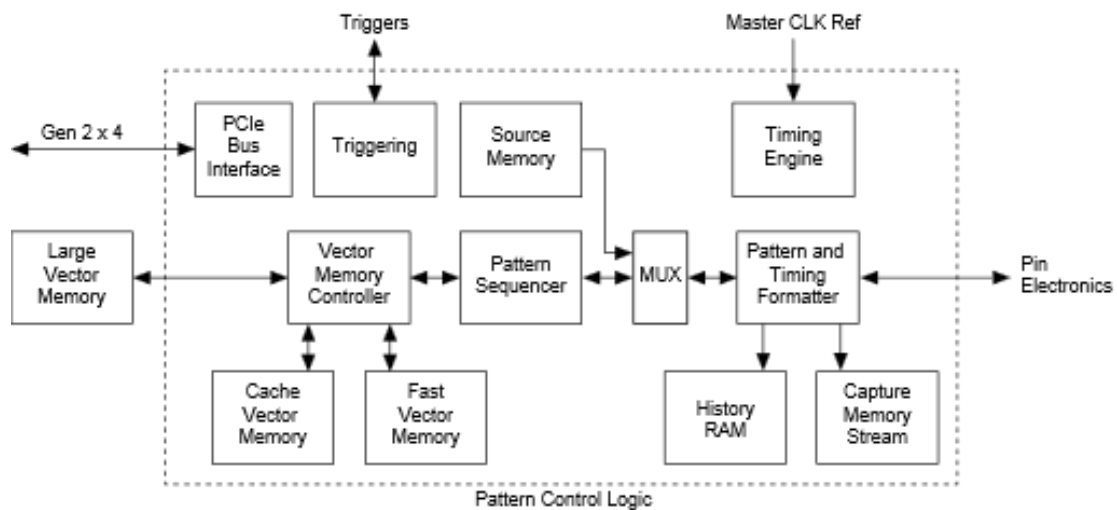

Figure 1. PXI Digital Pattern Instruments offer advanced ATE memory features like history, source, and capture memory with the right levels of user abstraction.

## Timing and Execution

PXI Digital Pattern Instruments burst digital data based on patterns that are made up of individual vectors. The time set includes the period of the vector in time, a drive format for the pin, and placement of the digital edges.

The drive formats, or vector formats, supported by these instruments are non-return, return to low, return to high, and surround by complement. Having the ability to use all of these formats gives engineers the ability to make the most efficient digital interface with as few vectors as necessary.

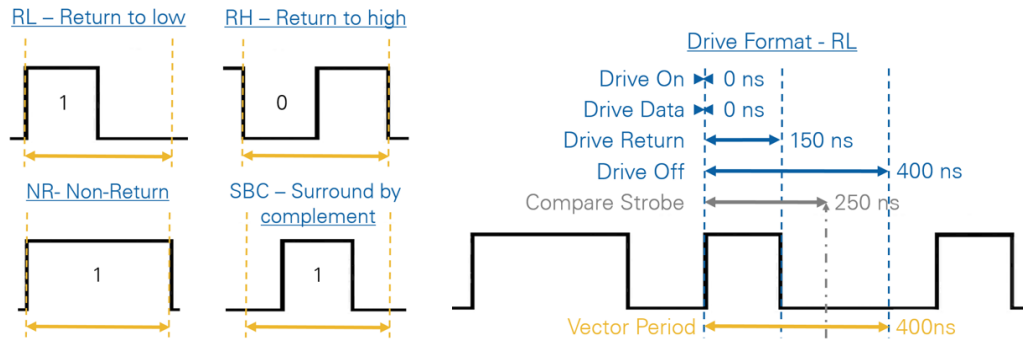

Figure 2. The combination of drive format and pattern value will determine what the digital waveform looks like. Each time set for a PXI Digital Pattern Instrument has a defined period, up to six drive edges, and a compare strobe.

The time sets for a PXI Digital Pattern Instrument have up to six drive edges and a compare strobe to act on the formats defined above. Drive on and drive off are edges that determine when the pin drivers will enable and disable. Drive data and drive return define when the pin driver will assert a high or low level. The drive return edge is only used in return vector formats. The compare strobe specifies the time in a vector when the pin comparator determines if the pin is at a high, low, or midband voltage level based on defined thresholds.

## Pin Electronics

Pin electronics provide the electrical interface to the DUT and allows the engineer to drive or receive digital data and emulate the conditions of other loads and components interacting with the device.

In a drive state, the pin driver of the pin electronics is engaged and forces the voltage on the pin to be low or high as determined by a 0 or 1 in the pattern. A pin driver will source or sink up to 32 mA to achieve the defined high or low value on the pin when enabled. Digital pattern instruments use 0 and 1 to represent drive pin states.

Compare states are non-drive states that use the comparators of the pin electronics to assess incoming data against predefined thresholds. Comparators are included in pin electronics and have settable levels for high and low voltages that are made in context to the DUT. To represent the different non-drive states that a pin can take, L, H, X, V, E, and M are all used.

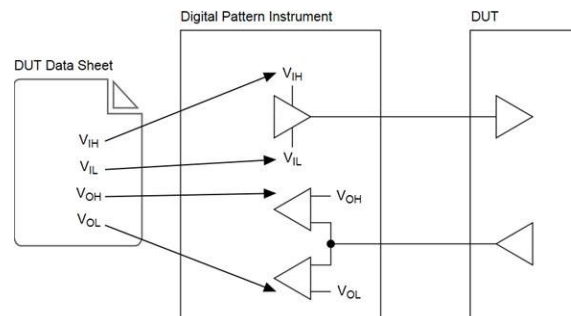

Figure 3. Pin drivers and comparators within the pin electronics use defined voltage levels for drive and compare states in the digital pattern.

## NI STS Integration and Digital System Synchronization

PXI Digital Pattern Instruments make up the digital test subsystem of the STS. The instruments are supported in all STS software and are calibrated using a timing calibration load board and a DC calibration load board, both from NI. The diagnostic software and calibration tools ensure high reliability and uptime of the system. It also gives a single system the ability to have many unified digital test resources.



Figure 4. With PXI Digital Pattern Instruments, more test engineers can take advantage of the STS, a PXI-based, open platform semiconductor production test system.

## Synchronization and Integration

PXI Digital Pattern Instruments can be synchronized together within a single PXI chassis using a PXI timing and synchronization module and the NI-Sync device driver. This synchronization can be done both within the STS and in a stand-alone PXI chassis. By synchronizing multiple instruments, a single digital subsystem can have up to 512 synchronized channels that achieve a specified edge placement accuracy performance. A unified digital subsystem can span single sites and combine match and failed conditions across multiple digital pattern instruments.



Figure 5. PXI Digital Pattern Instruments can be synchronized using a PXI Timing and Synchronization module to create a digital subsystem of many unified channels.



# Digital Pattern Editor Application Software

The Digital Pattern Editor is an interactive tool for importing, editing, or creating test patterns. The editor also includes tools like Shmoo plots to provide a deeper understanding of DUT performance across variation, as well as debug tools like overlaying pattern failures on a pattern or using digital scope to get an analog view of the pin data. Features like multisite and multi-instrument pattern bursting empower the engineer to expand from development into production leveraging the same workflow. All of the sheets developed in the Digital Pattern Editor can be reused by the API in LabVIEW, C, or .NET languages, as well as in the TestStand Semiconductor Module.

## Pattern Development and Format

A pattern file is a collection of vectors, with each vector containing time sets, labels, opcodes, pin states, and comments. The Digital Pattern Editor has development sheets for all of these items as well as debug tools for refining patterns, time sets, and specifications. A compiled, binary version of the pattern file is required to edit or burst. Engineers can compile an ASCII text pattern file format (.digipatsrc) into a binary version using the Digital Pattern Editor or a command line process. The ASCII form can be used to convert existing patterns by following the well-defined pattern file format. Design simulation and SCAN files generated by EDA tools can be cyclized and targeted to the NI format using existing customer in-house EDA workflows or third-party cyclizing tools.

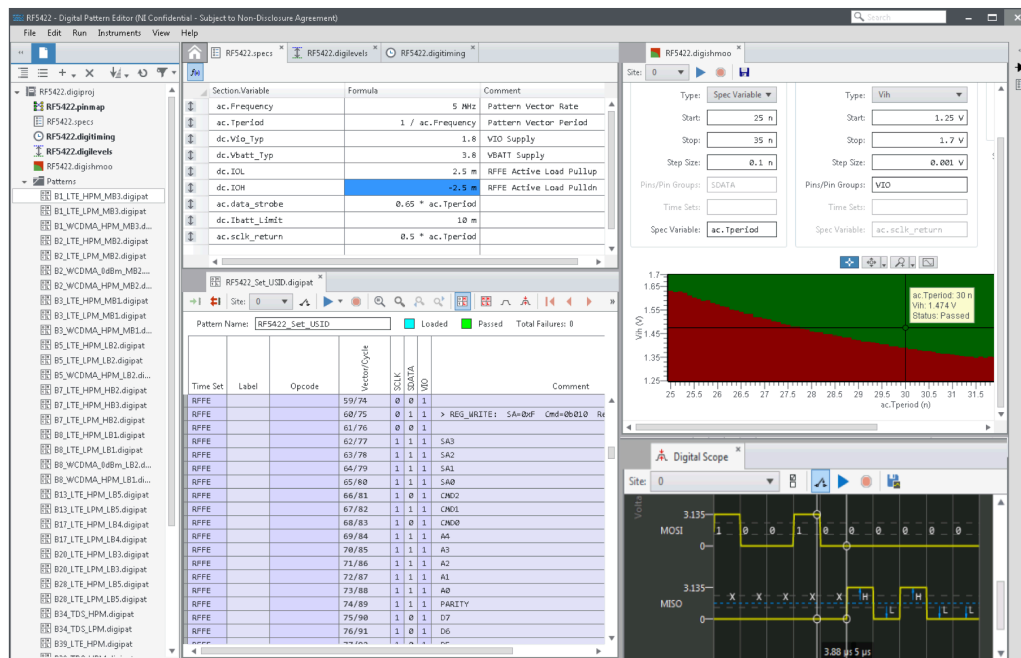

Figure 6. The Digital Pattern Editor is powerful development and debug software for semiconductor digital tests. The window can be configured to view development sheets and debugging tools all at the same time.

## History RAM Overlay Feature and History RAM View

Engineers can view the History RAM in two ways: using the History RAM overlay feature in the pattern document and looking at the History RAM view. The History RAM overlay displays the subset of burst results that corresponds to vectors in the current pattern based on the settings specified in the History RAM and signal setup pane. The History RAM view includes the corresponding time sets, labels, opcodes, pattern names, vectors/cycles, pin data, and comments. Rebursting a pattern overwrites the data in the History RAM overlay mode and in the History RAM view.

## Digital Scope

To aid engineers in debugging patterns, the digital scope tool displays a progressively updated two-dimensional plot of the actual analog levels of the digital waveform along with the expected data from the pattern.

## Shmoo Plot

The Shmoo tool displays a dynamically updated intensity plot of pass and fail values for a sweep of two variables. The Shmoo executes on multiple sites and engineers can switch the plot results displayed from site to site during the operation without hindering the sweep's completion.

The Shmoo can sweep up to two variables including levels, voltages, currents, edges, or specifications at a time. The Shmoo operation can execute in sweep, zigzag, progressive resolution, or edge traversal mode.



Figure 7. PXI Digital Pattern Instruments and the Digital Pattern Editor give semiconductor test engineers the features and tools they need in characterization and production.

## NI-Digital Pattern Application Programming Interface (API)

The [NI-Digital Pattern Driver](#) includes a best-in-class API that works with a variety of development options such as LabVIEW, C, and .NET languages. To ensure long-term interoperability of PXI Digital Pattern Instruments, the NI-Digital Pattern Driver API is the same API used for all past and current PXI Digital Pattern Instruments. The driver also provides access to help files, documentation, and ready-to-run shipping examples you can use as a starting point for your application.

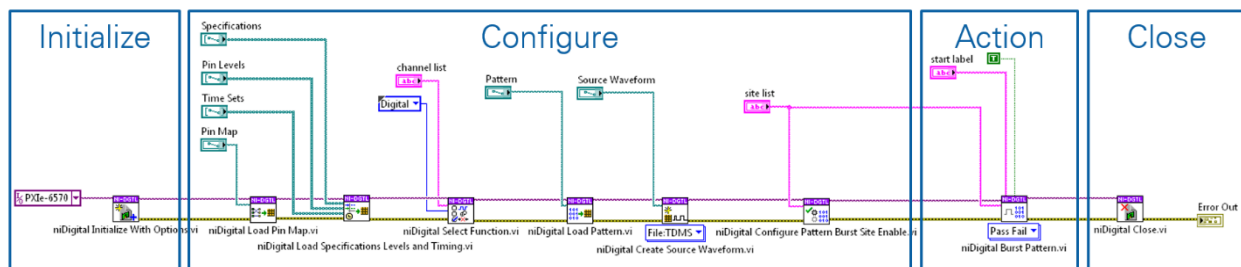



# Platform-Based Approach to Test and Measurement



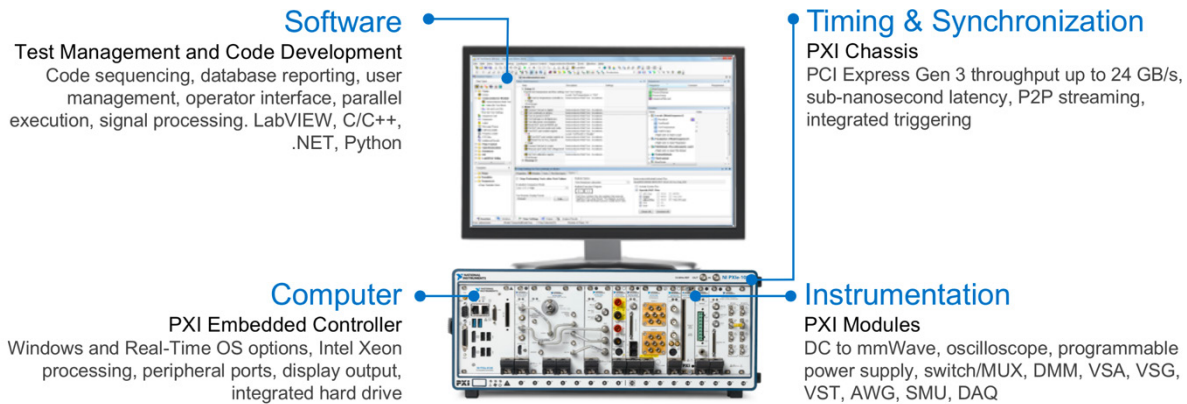

## What Is PXI?

Powered by software, PXI is a rugged PC-based platform for measurement and automation systems. PXI combines PCI electrical-bus features with the modular, Eurocard packaging of CompactPCI and then adds specialized synchronization buses and key software features. PXI is both a high-performance and low-cost deployment platform for applications such as manufacturing test, military and aerospace, machine monitoring, automotive, and industrial test. Developed in 1997 and launched in 1998, PXI is an open industry standard governed by the PXI Systems Alliance (PXISA), a group of more than 70 companies chartered to promote the PXI standard, ensure interoperability, and maintain the PXI specification.



## Integrating the Latest Commercial Technology

By leveraging the latest commercial technology for our products, we can continually deliver high-performance and high-quality products to our users at a competitive price. The latest PCI Express Gen 3 switches deliver higher data throughput, the latest Intel multicore processors facilitate faster and more efficient parallel (multisite) testing, the latest FPGAs from Xilinx help to push signal processing algorithms to the edge to accelerate measurements, and the latest data converters from TI and ADI continually increase the measurement range and performance of our instrumentation.

<p>HIGHER DATA THROUGHPUT</p>  <p>PCI Express Gen 3</p>	<p>PARALLEL TEST EXECUTION</p>  <p>Multicore Processors</p>	<p>MEASUREMENT ACCELERATION</p>  <p>FPGAs</p>	<p>INCREASED MEASUREMENT RANGE</p>  <p>Data Converters</p>
--	--	---	---

# PXI Instrumentation

NI offers more than 600 different PXI modules ranging from DC to mmWave. Because PXI is an open industry standard, nearly 1,500 products are available from more than 70 different instrument vendors. With standard processing and control functions designated to a controller, PXI instruments need to contain only the actual instrumentation circuitry, which provides effective performance in a small footprint. Combined with a chassis and controller, PXI systems feature high-throughput data movement using PCI Express bus interfaces and sub-nanosecond synchronization with integrated timing and triggering.



## Oscilloscopes

Sample at speeds up to 12.5 GS/s with 5 GHz of analog bandwidth, featuring numerous triggering modes and deep onboard memory



## Digital Multimeters

Perform voltage (up to 1000 V), current (up to 3A), resistance, inductance, capacitance, and frequency/period measurements, as well as diode tests



## Digital Instruments

Perform characterization and production test of semiconductor devices with timing sets and per channel pin parametric measurement unit (PPMU)



## Waveform Generators

Generate standard functions including sine, square, triangle, and ramp as well as user-defined, arbitrary waveforms



## Frequency Counters

Perform counter timer tasks such as event counting and encoder position, period, pulse, and frequency measurements



## Source Measure Units

Combine high-precision source and measure capability with high channel density, deterministic hardware sequencing, and SourceAdapt transient optimization



## Power Supplies & Loads

Supply programmable DC power, with some modules including isolated channels, output disconnect functionality, and remote sense



## FlexRIO Custom Instruments & Processing

Provide high-performance I/O and powerful FPGAs for applications that require more than standard instruments can offer



## Switches (Matrix & MUX)

Feature a variety of relay types and row/column configurations to simplify wiring in automated test systems



## Vector Signal Transceivers

Combine a vector signal generator and vector signal analyzer with FPGA-based, real-time signal processing and control



## GPIO, Serial, & Ethernet

Integrate non-PXI instruments into a PXI system through various instrument control interfaces



## Data Acquisition Modules

Provide a mix of analog I/O, digital I/O, counter/timer, and trigger functionality for measuring electrical or physical phenomena

# Hardware Services

All NI hardware includes a one-year warranty for basic repair coverage, and calibration in adherence to NI specifications prior to shipment. PXI systems also include basic assembly and a functional test. NI offers additional entitlements to improve uptime and lower maintenance costs with service programs for hardware. Learn more at [ni.com/services/hardware](http://ni.com/services/hardware).

	Standard	Premium	Description
Program Duration	1, 3, or 5 years	1, 3, or 5 years	Length of service program
Extended Repair Coverage	•	•	NI restores your device's functionality and includes firmware updates and factory calibration.
System Configuration, Assembly, and Test <sup>1</sup>	•	•	NI technicians assemble, install software in, and test your system per your custom configuration prior to shipment.
Advanced Replacement <sup>2</sup>		•	NI stocks replacement hardware that can be shipped immediately if a repair is needed.
System Return Material Authorization (RMA) <sup>1</sup>		•	NI accepts the delivery of fully assembled systems when performing repair services.
Calibration Plan (Optional)	Standard	Expedited <sup>3</sup>	NI performs the requested level of calibration at the specified calibration interval for the duration of the service program.

<sup>1</sup>This option is only available for PXI, CompactRIO, and CompactDAQ systems.

<sup>2</sup>This option is not available for all products in all countries. Contact your local NI sales engineer to confirm availability.

<sup>3</sup>Expedited calibration only includes traceable levels.

## PremiumPlus Service Program

NI can customize the offerings listed above, or offer additional entitlements such as on-site calibration, custom sparring, and life-cycle services through a PremiumPlus Service Program. Contact your NI sales representative to learn more.

## Technical Support

Every NI system includes a 30-day trial for phone and e-mail support from NI engineers, which can be extended through a [Software Service Program \(SSP\)](#) membership. NI has more than 400 support engineers available around the globe to provide local support in more than 30 languages. Additionally, take advantage of NI's award winning [online resources](#) and [communities](#).

©2019 National Instruments. All rights reserved. LabVIEW, National Instruments, NI, NI TestStand, and ni.com are trademarks of National Instruments. Other product and company names listed are trademarks or trade names of their respective companies. The contents of this Site could contain technical inaccuracies, typographical errors or out-of-date information. Information may be updated or changed at any time, without notice. Visit [ni.com/manuals](http://ni.com/manuals) for the latest information.

10 December 2019