PXle-4147 Specifications

2023-04-11



Contents

PXIe-4147 Specifications..... 3

PXIe-4147 Specifications

Definitions

Warranted specifications describe the performance of a model under stated operating conditions and are covered by the model warranty.

Characteristics describe values that are relevant to the use of the model under stated operating conditions but are not covered by the model warranty.

- **Typical** specifications describe the performance met by a majority of models.
- **Nominal** specifications describe an attribute that is based on design, conformance testing, or supplemental testing.
- **Measured** specifications describe the measured performance of a representative model.

Specifications are **Warranted** unless otherwise noted.

Conditions

Specifications are valid under the following conditions unless otherwise noted.

- Ambient temperature^[1] of $23\text{ °C} \pm 5\text{ °C}$
- Relative humidity between 10% and 70%, noncondensing. See [Programming and Measurement Accuracy/Resolution](#) for additional performance derating when operating above 70% relative humidity.
- Chassis with slot cooling capacity $\geq 38\text{ W}$ ^[2]
 - For chassis with slot cooling capacity = 38 W, fan speed set to HIGH
- Calibration interval of 1 year
- 30 minutes warm-up time
- Self-calibration performed within the last 24 hours

- niDCPower Aperture Time property or NIDCPOWER_ATTR_APERTURE_TIME attribute set to 2 power-line cycles (PLC)

Block Diagrams

Figure 1. PXIe-4147 Block Diagram

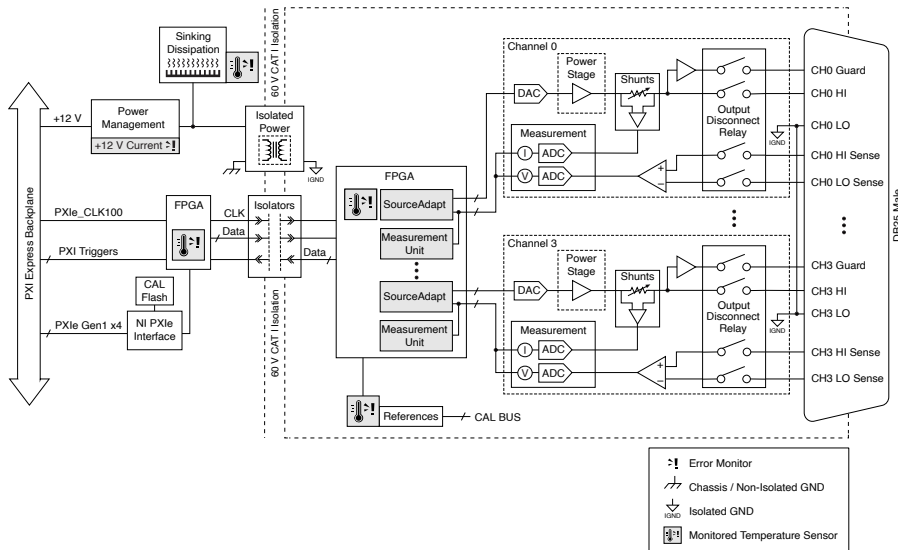
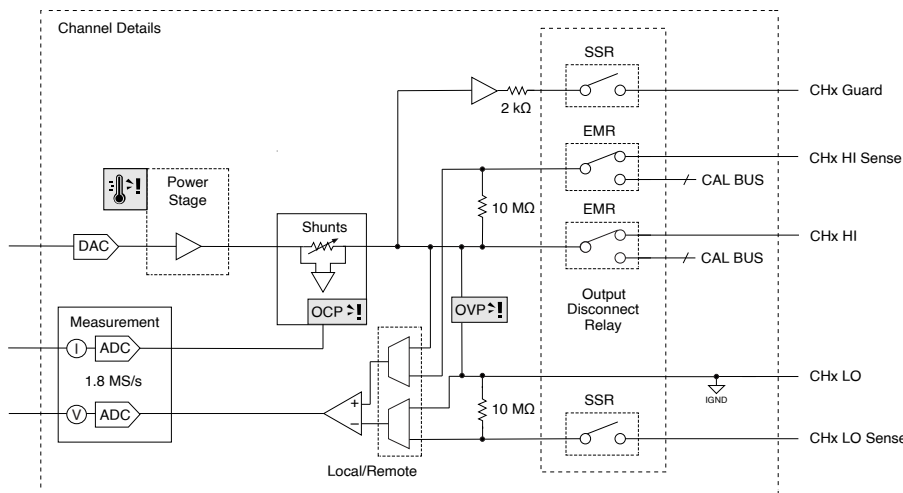

Figure 2. Channel-Level Block Diagram



Instrument Capabilities

Channels	0 through 3 ^[3]
----------	----------------------------

DC voltage ranges	1 V, 8 V
DC current ranges	1 μ A, 10 μ A, 100 μ A, 1 mA, 10 mA, 100 mA, 3 A

The following figure illustrates the voltage and the current source and sink ranges of the PXIe-4147.

Figure 1. PXIe-4147 Quadrant Diagram, Any Channel

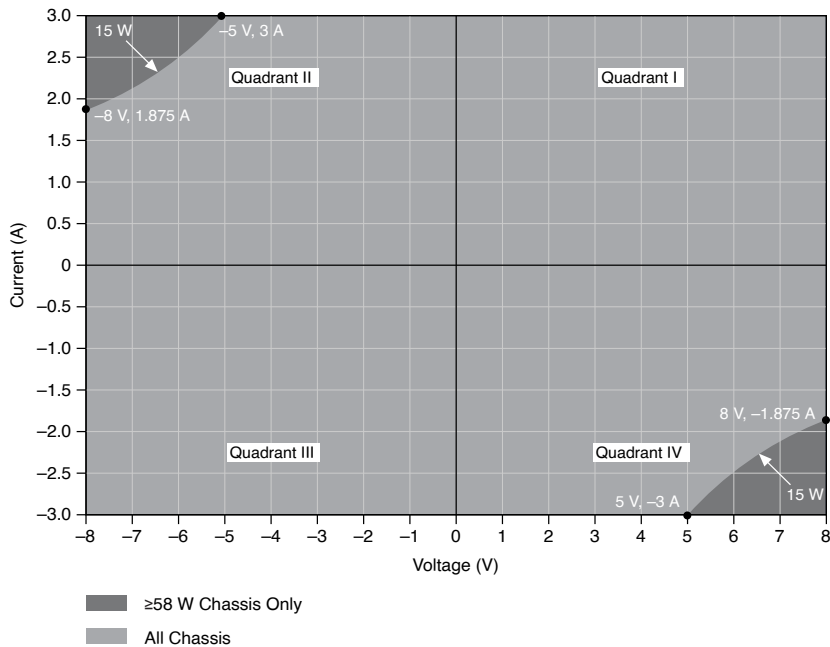

Available DC output power^[4]	
Sourcing^[5]	
All chassis	24 W per channel and 40 W total
Sinking	
≥ 58 W Slot Cooling Capacity Chassis ^[6]	24 W per channel and 40 W total
<58 W Slot Cooling Capacity Chassis	15 W per channel and 15 W total

Voltage

Table 1. Voltage Programming and Measurement Accuracy/Resolution

Range	Resolution (Noise Limited)	Noise (0.1 Hz to 10 Hz, peak-to-peak, typical)	Accuracy \pm (% of Voltage + Offset) ^[7]		Tempco ^[8] \pm (% of Voltage + Offset)/°C
			T _{ambient} 23 °C \pm 5 °C, T _{cal} ^[9] \pm 5 °C		
			Multiple Channels ^[10]	Single Channel ^[11]	T _{ambient} 0 °C to 55 °C, T _{cal} \pm 5 °C
1 V	100 nV	2 μ V	0.025% + 110 μ V	0.02% + 70 μ V	0.0002% + 1 μ V
8 V	1 μ V	12 μ V	0.02% + 600 μ V	0.015% + 400 μ V	

Current

Table 2. Current Programming and Measurement Accuracy/Resolution

Range	Resolution (Noise Limited)	Noise (0.1 Hz to 10 Hz, peak-to-peak, typical)	Accuracy \pm (% of Current + Offset) ^[12]		Tempco ^[13] \pm (% of Current + Offset)/°C
			T _{ambient} 23 °C \pm 5 °C, T _{cal} ^[14] \pm 5 °C		
			Multiple Channels ^[15]	Single Channel	T _{ambient} 0 °C to 55 °C, T _{cal} \pm 5 °C
1 μ A	100 fA	8 pA	0.045% + 250 pA	0.035% + 150 pA	0.0003% + 2 pA
10 μ A	1 pA	60 pA	0.05% + 1.6 nA	0.035% + 1 nA	
100 μ A	10 pA	400 pA	0.045% + 14 nA	0.035% + 8 nA	
1 mA	100 pA	4 nA	0.04% + 120 nA	0.03% + 70 nA	
10 mA	1 nA	40 nA	0.04% + 1.2 μ A	0.03% + 700 nA	
100 mA	10 nA	400 nA	0.045% + 12 μ A	0.035% + 7 μ A	
3 A	1 μ A	40 μ A	0.07% + 800 μ A	0.07% + 400 μ A	

Noise

Wideband source noise ^[17]	<10 mV _{pk-pk} , typical
---------------------------------------	-----------------------------------

The following figures illustrate measurement noise as a function of measurement aperture for the PXIe-4147.

Figure 1. Voltage RMS Noise Versus Aperture Time, Nominal

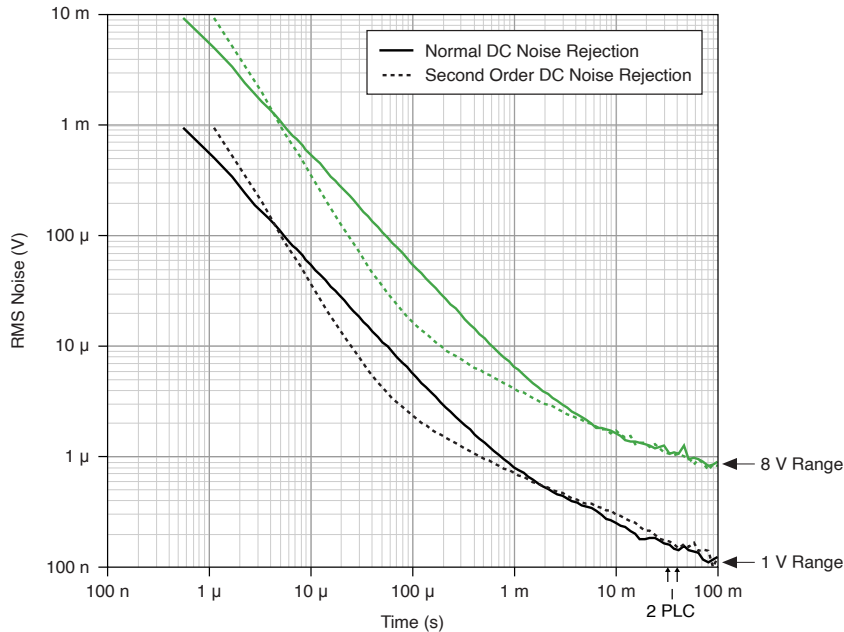

Note When the aperture time is set to two power-line cycles (PLCs), measurement noise differs slightly depending on whether the niDCPower Power Line Frequency property or NIDCPOWER_ATTR_POWER_LINE_FREQUENCY attribute is set to 50 Hz or 60 Hz.



Note To configure normal or second-order DC noise rejection, set the niDCPower DC Noise Rejection property or NIDCPOWER_ATTR_DC_NOISE_REJECTION attribute.

Figure 1. Current RMS Noise Versus Aperture Time, Nominal

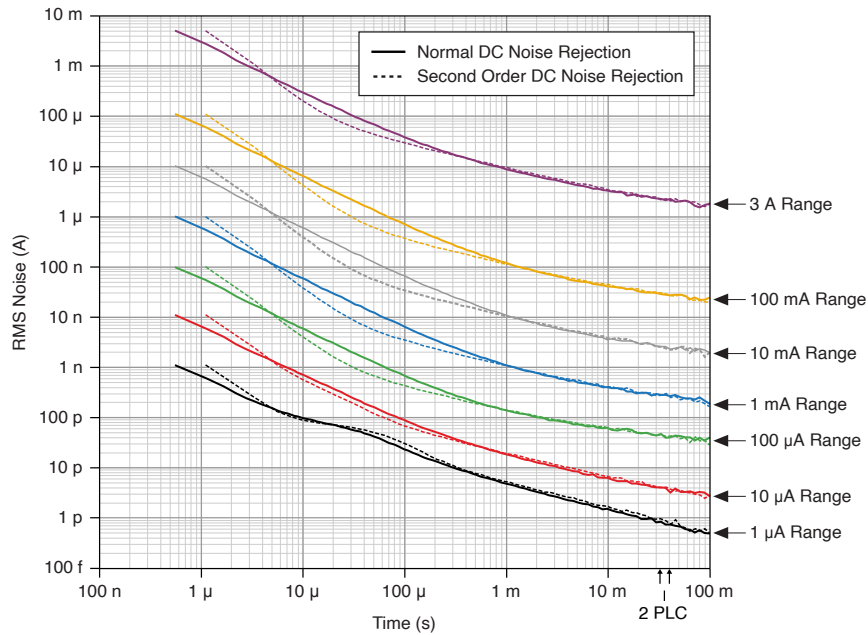

Note When the aperture time is set to two power-line cycles (PLCs), measurement noise differs slightly depending on whether the niDCPower Power Line Frequency property or NIDCPOWER_ATTR_POWER_LINE_FREQUENCY attribute is set to 50 Hz or 60 Hz.



Note To configure normal or second-order DC noise rejection, set the niDCPower DC Noise Rejection property or NIDCPOWER_ATTR_DC_NOISE_REJECTION attribute.

Transient Response and Settling Time

Settling time^[18]	
Voltage mode, ≤ 4 V step, unloaded ^[19]	<50 μ s, typical
Current mode, full-scale step, 3 A to 100 μ A ranges ^[20]	<50 μ s, typical

Current mode, full-scale step, 10 μA range ^[20]	<100 μs , typical
Current mode, full-scale step, 1 μA range ^[20]	<200 μs , typical
Transient response^[21]	
3 A to 100 μA ranges	<40 μs , typical
10 μA range	<100 μs , typical
1 μA range	<200 μs , typical

Remote Sense

Voltage accuracy	Add (10 ppm of voltage range + 25 μV) per volt of LO lead drop, plus 10 μV per volt of HI lead drop to voltage accuracy specification
Maximum sense lead resistance	100 Ω
Maximum lead drop per lead	1 V, maximum 8 V between HI and LO terminals

Load Regulation

Voltage, local sense ^[22]	100 $\mu\text{V}/\text{mA}$, nominal; 200 $\mu\text{V}/\text{mA}$, maximum
Voltage, remote sense	Error included in accuracy specifications.
Current	Error included in accuracy specifications.

Isolation

Isolation voltage, any pin to earth ground ^[23]	60 V DC, CAT I
Withstand voltage	800 V _{pk}

Protection

Absolute maximum voltage to Output LO, all pins	
Output HI	±10 V
All other pins	±60 V
Output channel protection	
Overcurrent or overvoltage	Automatic shutdown, output disconnect relay opens
Overtemperature	Automatic shutdown, output disconnect relay opens

Guard Output Characteristics

Cable guard	
Output impedance	2 k Ω , nominal
Offset voltage	1 mV, typical

Output Resistance Programming Accuracy

Table 3. Output Resistance Programming Accuracy

Current Level/ Limit Range	Voltage Mode		Current Mode	
	Programmable Resistance Range	Accuracy, \pm (% of Resistance Setting + Offset) ^[24]	Programmable Resistance Range	Accuracy, \pm (% of resistance setting Offset) ^[24]
1 μ A	0 to \pm 4 M Ω	0.05% + 100 Ω	\pm 2.5 M Ω to \pm infinity	0.05% 100 G Ω
10 μ A	0 to \pm 400 k Ω	0.05% + 10 Ω	\pm 250 k Ω to \pm infinity	0.05% 10 G Ω
100 μ A	0 to \pm 40 k Ω	0.05% + 1 Ω	\pm 25 k Ω to \pm infinity	0.05% 1 G Ω
1 mA	0 to \pm 4 k Ω	0.05% + 100 m Ω	\pm 2.5 k Ω to \pm infinity	0.05% 100 M Ω
10 mA	0 to \pm 400 Ω	0.05% + 10 m Ω	\pm 250 Ω to \pm infinity	0.05% 10 M Ω
100 mA	0 to \pm 40 Ω	0.05% + 1 m Ω	\pm 25 Ω to \pm infinity	0.05% 1 M Ω
3 A	0 to \pm 1.25 Ω	0.08% + 100 $\mu\Omega$	\pm 750 m Ω to \pm infinity	0.08% 10 k Ω

Measurement and Update Timing

Available sample rates ^[25]	(1.8 MS/s)/N, nominal
where	
<ul style="list-style-type: none"> ▪ N = 1, 2, 3, ... 2²⁴ ▪ S is samples 	
Sample rate accuracy	Equal to PXIe_CLK100 accuracy, nominal
Maximum measure rate to host	1.8 MS/s per channel, continuous, nominal

Maximum source update rate ^[26]	100,000 updates/s, nominal
Input trigger to	
Source event delay	10 μ s, nominal
Source event jitter	2 μ s _{pk-pk} , nominal
Measure event jitter	2 μ s _{pk-pk} , nominal

Triggers

Input triggers	
Types	Start Source Sequence Advance Measure
Sources (PXI trigger lines 0 to 7)^[27]	
Polarity	Active high (not configurable)
Minimum pulse width	100 ns
Destinations^[28] (PXI trigger lines 0 to 7)^[27]	
Polarity	Active high (not configurable)
Minimum pulse width	>200 ns
Output triggers (events)	
Types	Source Complete

	Sequence Iteration Complete
	Sequence Engine Done
	Measure Complete
Destinations (PXI trigger lines 0 to 7)^[27]	
Polarity	Active high (not configurable)
Pulse width	230 ns

Physical

Dimensions	3U, one-slot, PXI Express/CompactPCI Express module 2.0 cm × 13.0 cm × 21.6 cm (0.8 in. × 5.1 in. × 8.5 in.)
Weight	
20 W	448 g (15.8 oz)
40 W	428 g (15.1 oz)
Front panel connectors	25-position D-SUB, male

Calibration Interval

Recommended calibration interval	1 year
----------------------------------	--------

Power Requirements

+3.3 V	1 A, typical
+12 V	1.3 A, typical at idle; 6 A, maximum at full load

Environmental Characteristics

Temperature and Humidity

Temperature	
Operating	0 °C to 55 °C ^[29]
Storage	-40 °C to 71 °C
Humidity	
Operating	10% to 90%, noncondensing ^[30]
Storage	5% to 95%, noncondensing
Pollution Degree	2
Maximum altitude	2,000 m (800 mbar) (at 25 °C ambient temperature)

¹ The ambient temperature of a PXI system is defined as the temperature at the chassis fan inlet (air intake).

² For increased capability, NI recommends installing the PXIe-4147 in a chassis with slot cooling capacity ≥ 58 W.

³ Channels isolated from earth ground, but share a common LO for all channels (bank isolation).

- ⁴ Power limit defined by voltage measured between HI and LO terminals.
- ⁵ Sourcing power may be limited by total power available from the chassis power supply. Refer to the [Performing a Power Budget on a PXI/PXIe System](#) article for more information.
- ⁶ When sinking more than 15 W into the PXIe-4147, transients may not exceed 200 mW/ μ s.
- ⁷ Refer to the [Remote Sense](#) and [Load Regulation](#) sections for additional accuracy derating and conditions.
- ⁸ Temperature coefficient applies beyond 23 °C \pm 5 °C ambient within \pm 5 °C of T_{cal} .
- ⁹ T_{cal} is the internal device temperature recorded by the PXIe-4147 at the completion of the last self-calibration.
- ¹⁰ Multiple-channel specifications apply whenever two or more channels are connected and sourcing/sinking current. Multiple-channel specifications account for interactions between the channels when operated at high current, including board heating.
- ¹¹ Single-channel specifications assume only one channel is connected and sourcing/sinking current which results in improved accuracy due to the reduction of effects between the channels, including board heating. When transitioning from a multiple-channel configuration to a single-channel configuration, a ten-minute cool down period is required to meet Single Channel accuracy specifications.
- ¹² Relative humidity between 10% and 70%, noncondensing. When operating above 70% relative humidity, add 30 pA to current accuracy specifications.
- ¹³ Temperature coefficient applies beyond 23 °C \pm 5 °C ambient within \pm 5 °C of T_{cal} .
- ¹⁴ T_{cal} is the internal device temperature recorded by the PXIe-4147 at the completion of the last self-calibration.

¹⁵ Multiple-channel specifications apply whenever two or more channels are connected and sourcing/sinking current. Multiple-channel specifications account for interactions between the channels when operated at high current, including board heating.

¹⁶ Single-channel specifications assume only one channel is connected and sourcing/sinking current which results in improved accuracy due to the reduction of effects between the channels, including board heating. When transitioning from a multiple-channel configuration to a single-channel configuration, a ten-minute cool down period is required to meet Single Channel accuracy specifications.

¹⁷ 10 Hz to 20 MHz bandwidth. PXIe-4147 configured for normal transient response.

¹⁸ Measured as the time to settle to within 0.1% of step amplitude, PXIe-4147 configured for fast transient response.

¹⁹ Current limit set to $\geq 30 \mu\text{A}$ and $\geq 20\%$ of the selected current limit range.

²⁰ Voltage limit set to $\geq 2 \text{ V}$, resistive load set to 1 V/selected current range.

²¹ Time to recover within 10 mV after a load current change from 10% to 90% of range, PXIe-4147 configured for fast transient response.

²² At the output terminals of attached TB-414X Screw Terminal Connector Kit.

²³ Channels isolated from earth ground, but share a common LO for all channels (bank isolation).

²⁴ Accuracy is typical and applies within $\pm 5 \text{ }^\circ\text{C}$ of last self calibration.

²⁵ When source-measuring, both the NI-DCPowerSource Delay and Aperture Time properties affect the sampling rate. When taking a measure record, only the Aperture Time property affects the sampling rate.

²⁶ As the source delay is adjusted or if advanced sequencing is used, maximum source update rates may vary.

27 Pulse widths and logic levels are compliant with **PXI Express Hardware Specification Revision 1.0 ECN 1**.

28 Input triggers can come from any source (PXI trigger or software trigger) and be exported to any PXI trigger line. This allows for easier multi-board synchronization regardless of the trigger source.

29 Not all chassis can achieve this ambient temperature range. Refer to PXI chassis specifications to determine the ambient temperature ranges your chassis can achieve.

30 When transitioning a device from a storage or operation environment with relative humidity above 70%, device should be allowed to stabilize in the lower humidity environment for several hours before use. Refer to the PXIe-4147 **Programming and Measurement Accuracy/Resolution** specifications for additional performance derating when operating above 70% relative humidity.