

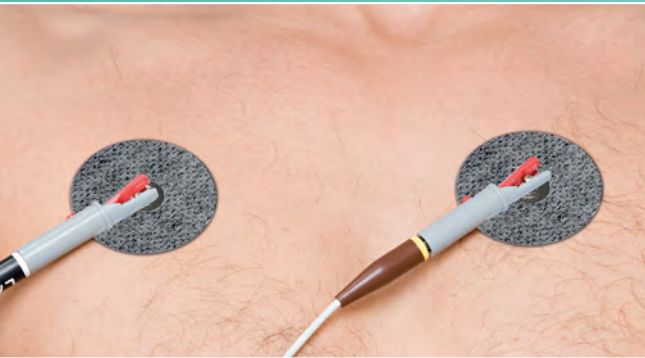

Healthcare

New Possibilities in Wearables, Diagnostics, and Labeling Solutions



OMNI-WAVE™

dermaFLEX™

PHARMcal®

MedFLEX®

What FLEXcon Healthcare Can Do For You

Over 65 years of experience as a purpose-driven material science company means that Converter and Medical Device Companies in the healthcare industry can count on FLEXcon to deliver comprehensive solutions, innovation, and engineering expertise. Our specialty is in manufacturing and coating films and adhesives, where customers take advantage of our product development expertise to create the ideal solution, and our flexibility to start small and scale up as needs change.

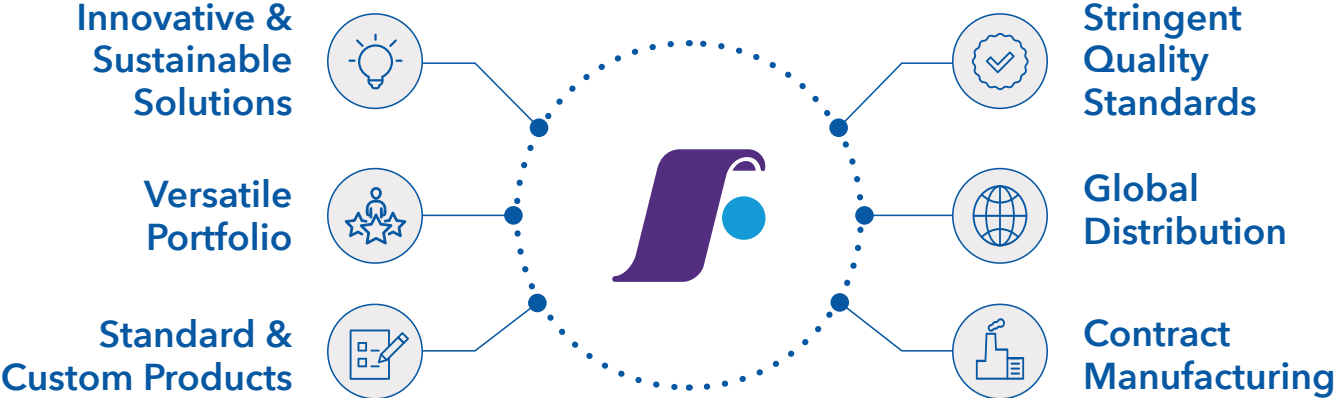

Customers We Support

Whether you are a converter, medical device company, or small start up, we are here to help you commercialize healthcare technologies. We recognize you are looking for a partner who is flexible, forward thinking, and innovative. Your goal is our goal, to deliver a solution that fits a need.

FLEXcon provides you with support for your application every step of the way, always striving for better patient outcomes.



Converter

- Wide Range of Product Offerings
- Sample Availability
- Technical Support
- Certificate of Analysis
- Flexible Order Quantities
- Quick-Ship Inventory to Converter



Start-Up and Large Medical Device Companies

- R&D Design Consultation and Collaboration
- Performance Solutions and Data
- Prototyping for Scale-Up
- ISO 9001:2015 Certified with TUV Rheinland of North America
- Quick-Ship Inventory
- Flexible Order Quantities
- Sample Availability



End User Patient

- Safe Medical Components
- Consistent Performance



Rapid Prototyping

- Product Design
- Lab Prototyping
- Custom Testing
- Formulation
- Chemistry Modification & Custom Mixing



Coating

- Adhesive Coating
- Topcoating
- ISO Class 7 Cleanroom
- Adhesive Thickness Range from 0.5 mil to 4 mil
- Single and Double-sided Coating
- Zone Coating

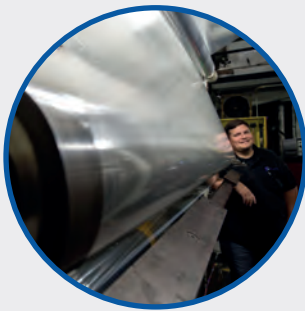

Laminating

- Multilayer Laminations
- Heat Laminations
- Cold Laminations

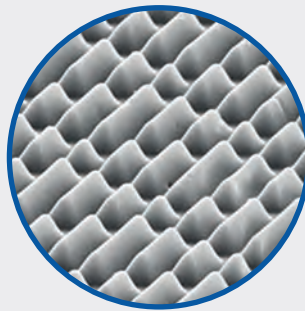

Surface Modification

- Micro-embossing
- Perforation
- Brushing
- Nano-Imprint Lithography

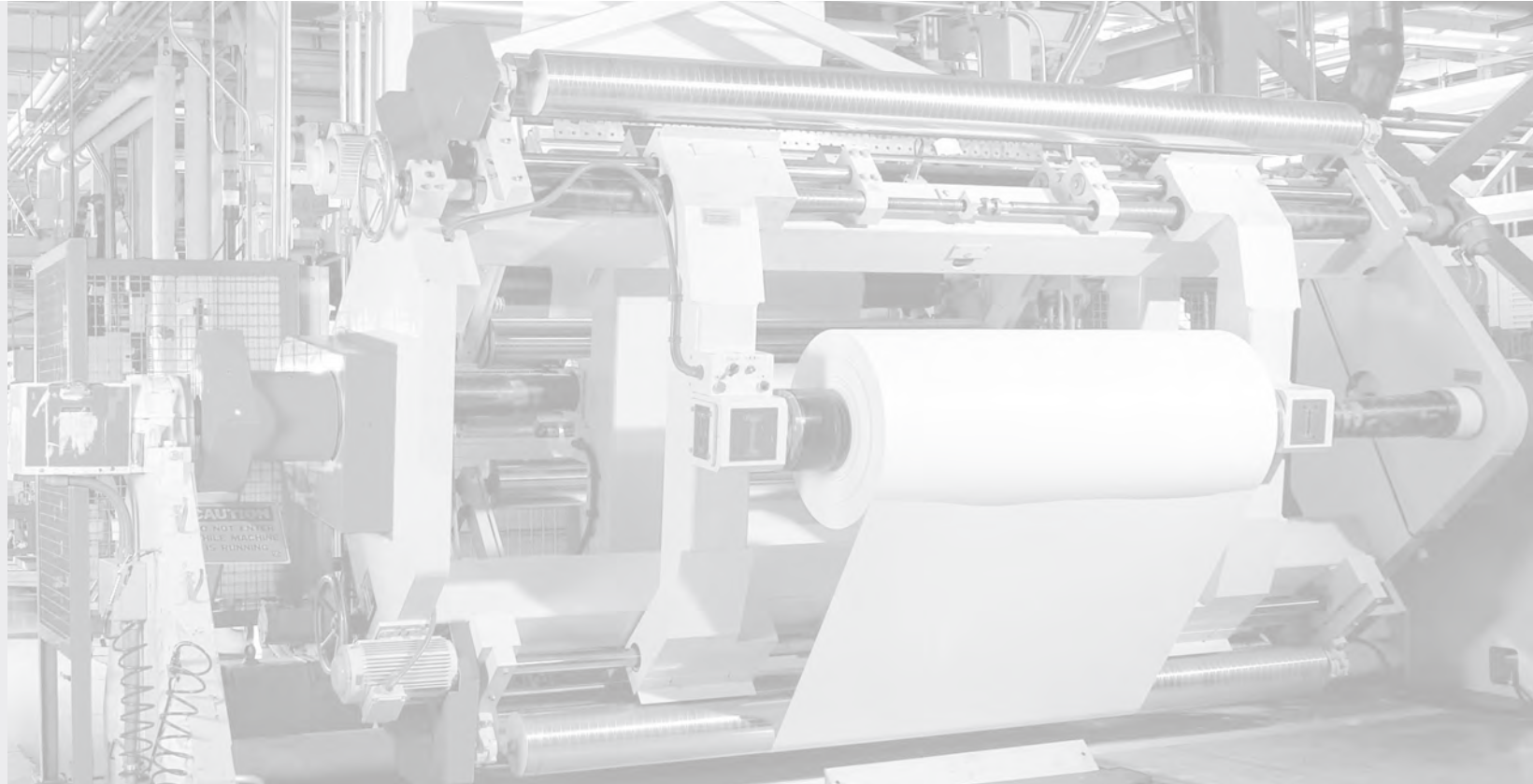

Healthcare Segments

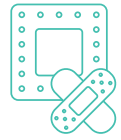

Wearables

Skin-Friendly Adhesives and Flexible Substrates



Diagnostics & Therapeutics

Conductive Adhesive Transfer Tapes



Personal Wellness & Think Tank Technologies



Pharmaceutical Labeling

Drug Packaging Security



Medical Device Labeling



Wearables



Skin-Friendly Adhesives and Flexible Substrates

FLEXcon® dermaFLEX™ skin-friendly materials are intended for device attachment to the body. dermaFLEX™ adhesives have been tested for biocompatibility (skin irritation, sensitization, and cytotoxicity) by FLEXcon's adhesive suppliers using ISO-10993 or similar test methods*.

Choose from three tiers of adhesion - Gentle Release, General Use, or Long-Term Wear - as well as a variety of finished formats, including single-coated, double-coated, and transfer tapes.



Flexible



Extensible



Breathable



Soft



Conformable

Choose from standard product offerings, or create your own unique combination of flexible substrates and skin-friendly adhesives that are optimized for your specific application needs.

Flexible Substrates

-  Urethanes
-  Nylon-Reinforced Urethane (NNU)
-  Non-Wovens
-  Soft Foams

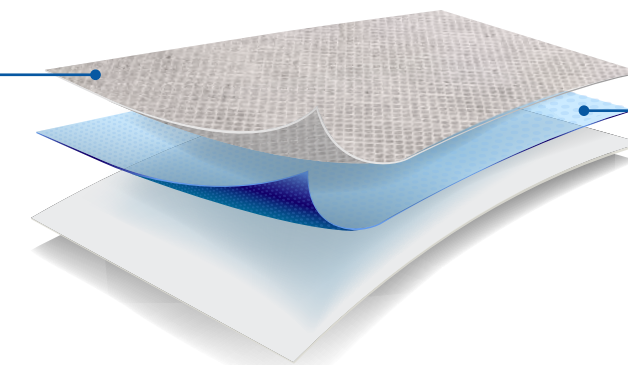

Gentle Release

3 days or less**

General Use

3-7 days**

Long-Term Wear

7+ days**

Three Tiers of Adhesion



Scan for more information, or visit www.FLEXcon.com/dermaFLEX

*Biocompatibility testing was completed using a similar 'source' adhesive in some circumstances. Full biocompatibility test results are available on the web or upon request.
 **Length of Wear is highly dependent on multiple factors such as adhesive type, adhesive thickness, substrate type, substrate thickness, product size and shape, location on body, skin type (hairy, diaphoretic, etc.), and activity level (showering & exercise), etc. This information is intended to be used as a guide to aid with product selection.

Diagnostics and Therapeutics



Conductive Adhesive Transfer Tapes

FLEXcon® OMNI-WAVE™ allows you to select the signaling material that will meet your application's biosensing needs. From **Long-Term Wear** to **Gentle Release**, OMNI-WAVE™ is a hydrogel-free adhesive technology which can be used in electrodes and sensors. OMNI-WAVE™ is AAMI Compliant and passes ISO 10993-10 for sensitization and irritation.

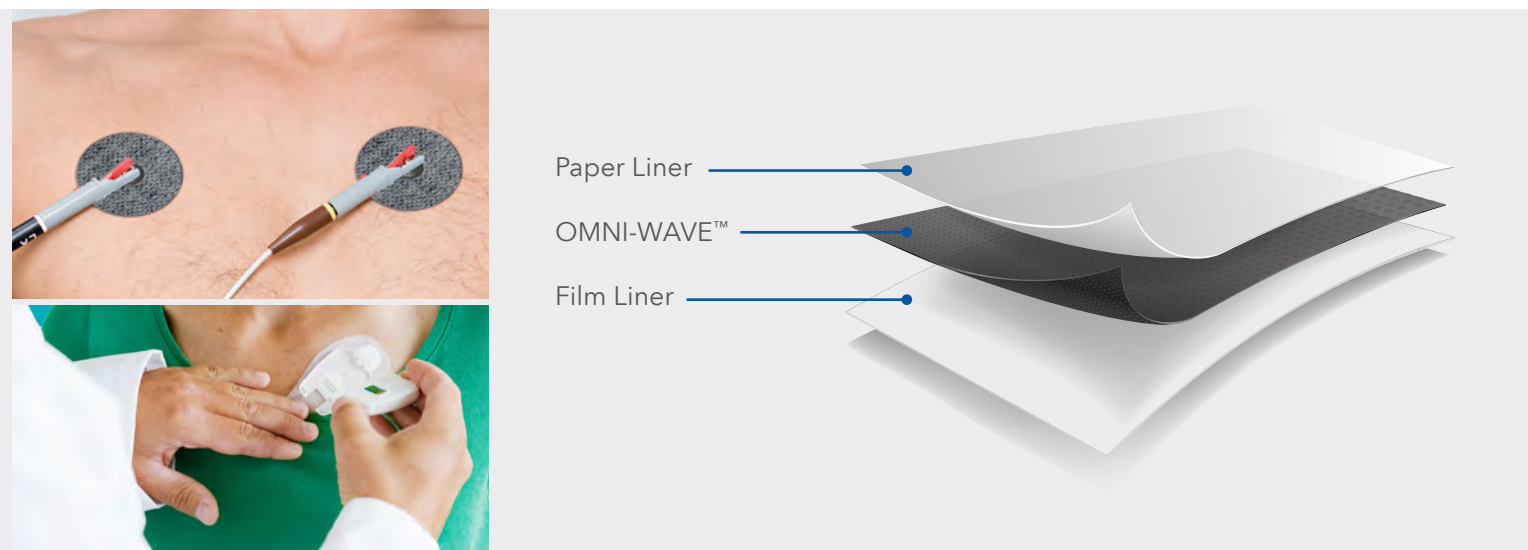

Benefits of Hydrogel-free Technology

- Limited skin irritation
- Longer out-of-pack shelf life
- Humidity agnostic
- Lower-cost packaging
- Manufacturing efficiency - more material on one roll compared to foam and hydrogel

OMNI-WAVE™ Diagnostic and Therapeutic Biosignaling Options

Diagnostic (ECG / sEMG / EDA)				Therapeutic	
Non-Stick	Gentle Release	Short-Term Wear	Long-Term Wear	Diaphoretic	Stimulation
For wearable applications	Neonatal, or fragile skin	< 3 Days	4 - 7+ days	For high-perspiration activities	Muscle and nerve stimulation (TENS)



Scan for more information and whitepapers, or visit www.FLEXcon.com/OMNI-WAVE

Personal Wellness and Think Tank Technologies

In our state-of-the-art Technology and Innovations Center, you will work with a technical team devoted to developing solutions that will enable your brainchild to be successful. Whatever the challenge, our team will help identify the components and processes that will provide the best results, create prototypes, conduct testing, provide samples, and scale up production when you're ready.

Recent Collaborations:

- **Single-use Fit Test Hoods** - for qualitative fit testing
- **Soft Silicone Adhesives** - for beauty and cosmetic applications
- **Sun Patch** - color changing coating that responds to UV light indicating too much sun exposure
- **Microfluidics** - precise micro channeled substrates



Collaboration and FLEXcon's coating capabilities bring new CO₂ Sensor Technology to Market

Polestar Technologies, Inc., a recognized leader in optical sensing technologies, had developed a revolutionary liquid sensory composite that can sense carbon dioxide (CO₂) levels in air, and they were ready to take it from the lab table to full-scale manufacturing.

Polestar needed a partner that could apply their coating to a substrate to be used in rebreathers on scuba tanks. Polestar and FLEXcon engaged in a repetitive trial process to create a feedback and feasibility loop which enabled engineers to hone the product to its final form and successfully produce it on a manufacturing scale. Says Jim Biagioni, COO at Polestar, "FLEXcon made it easy to take an idea from concept to reality."



Pharmaceutical Labeling

PHARMcal®

Medical Device Labeling

MedFLEX®

Drug Packaging and Security

The FLEXcon® PHARMcal® portfolio consists of six unique product families based on end-use application. Each is comprised of a full range of high-performance materials engineered to meet all your pharmaceutical labeling needs.

Specific PHARMcal® products comply with 21 CFR 175.105†, REACH, RoHS/WEE, and ISO 10993-5, -10‡.



Small Diameter Labeling



Large Diameter Labeling



Conceal



Cryogenics & Cold Chain



Security & Tamper-Evident



Blood Bag Labeling

FLEXcon® MedFLEX® products meet FDA standards and label durability that enable you to deliver labels designed specifically for the medical device industry. Selecting MedFLEX® products provides you with:

Easy Adoptions

Products are UL/cUL-recognized and immediately adoptable into your UL file, providing you with the label stock and finishes you need to produce a compliant medical device label.

Zero Adoption Costs

When specific minimum purchase conditions are met, FLEXcon will reimburse you for UL's flat adoption fee – reducing your transfer cost to zero.

FDA Compliance

Products comply with IEC 60601-1 3rd Edition, as amended, durability rub tests and achieves FDA's Title 21 Part 801 labeling requirements.



Exceptional Printability

- Reliable topcoats for conventional & digital ink systems to enable cross-platform printability and reduced SKUs
- Chemical & abrasion resistance for long-term readability



Engineered Films

- Dimensional stability for high-speed auto-dispense labeling applications

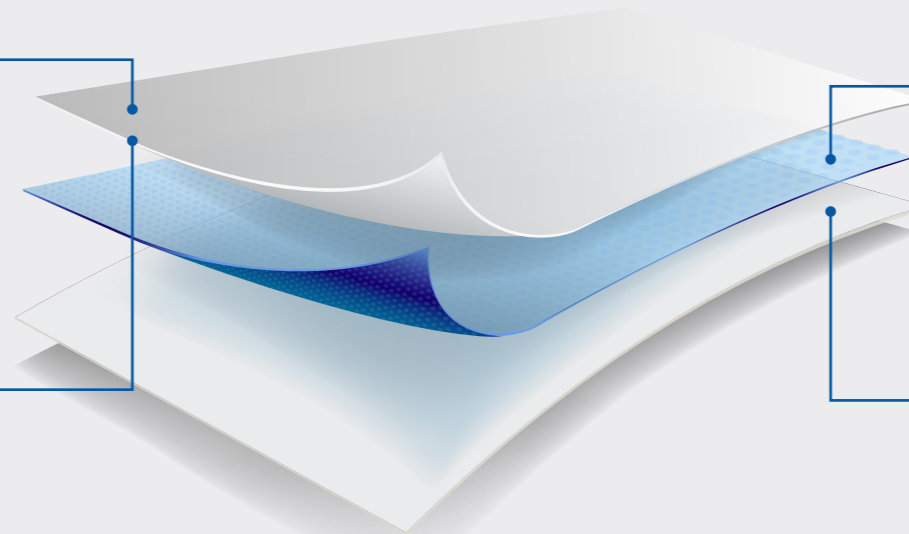

Robust Adhesion

- Adhesives developed specifically for the most challenging and demanding applications



Optimized Liners

- High-tensile strength allows for high-speed diecutting, matrix stripping, and auto-dispensing



Scan for more information, or visit www.FLEXcon.com/PHARMcal

†FDA CFR 175.105: Adhesives may be safely used as components of articles intended for use in packaging, transporting, or holding food in accordance with the following prescribed conditions ‡ISO 10993-5,-10: Tests for in vitro cytotoxicity, irritation, and sensitization



Scan for more information, or visit www.FLEXcon.com/MedFLEX



Supporting Businesses Globally

It takes an innovative spirit to try something no one else is willing to try, and that's exactly the spirit Myles M^cDonough had back in 1956 when he produced his first pressure-sensitive film product in a Spencer garage. **At a time when other film suppliers only wanted to produce commodity products** that could be run fast and at high volumes, **Myles had a vision - one where he would fill the needs of other innovators** who wanted to use pressure-sensitive films in new and different ways. These innovators needed a development partner to turn their ideas into reality.

Today, more than 65 years later, this spirit is still what sets FLEXcon apart. **Proudly serving industries from Packaging to Electronics and from Aerospace to Healthcare**, FLEXcon is a trusted manufacturing partner to help take your innovative ideas from concept to reality. **FLEXcon has been supplying the Healthcare industry with adhesives, tapes, films, and coating technologies for over 35 years** for applications that support Patient Care, Pharmaceuticals, Diagnostics and Consumer Wellness.

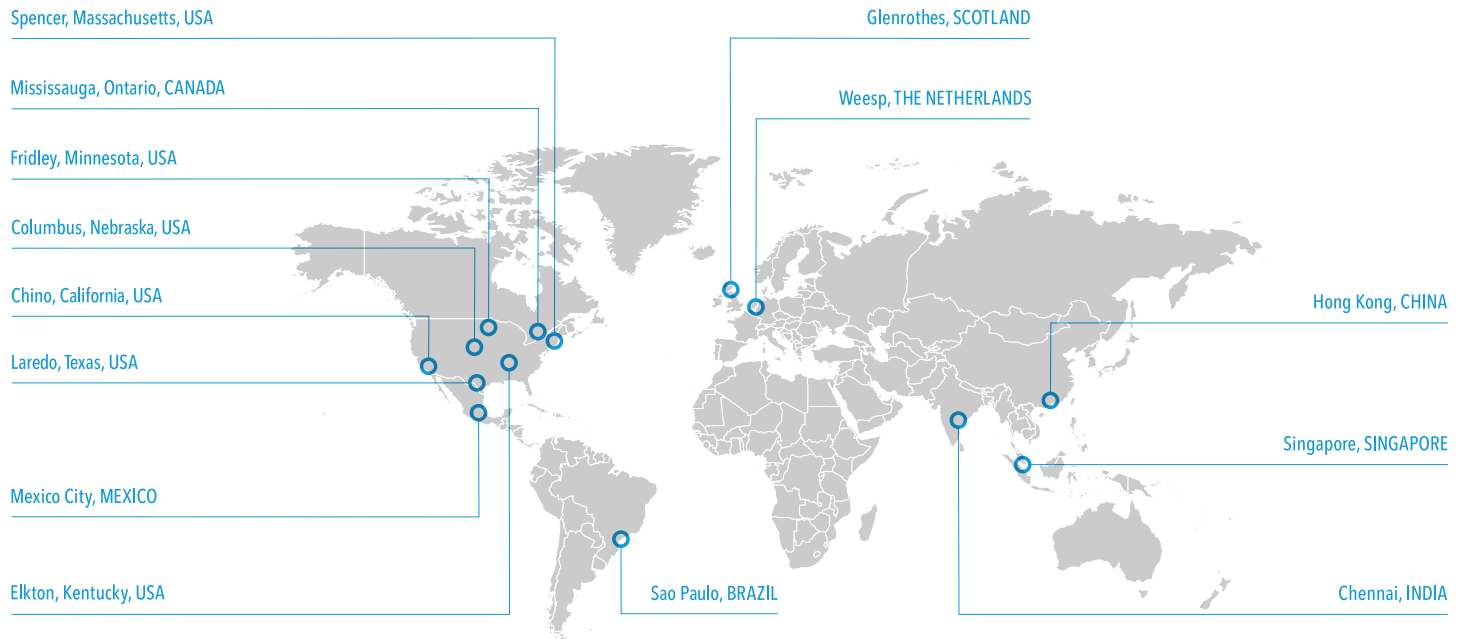

Product Performance and Suitability

All of the descriptive information, the typical performance data, and recommendations for the use of FLEXcon products shall be used only as a guide and do not reflect the specification or specification range for any particular property of the product. Furnishing such information is merely an attempt to assist you after you have indicated your contemplated use and shall in no event constitute a warranty of any kind by FLEXcon. All purchasers of FLEXcon products shall be responsible for independently determining the suitability of the material for the purpose for which it is purchased. No distributor, salesman, or representative of FLEXcon is authorized to give any warranty, guaranty, or make any representation in addition or contrary to the above.

**OMNI-WAVE™, dermaFLEX™, PHARMcal®, and MedFLEX® belong to the FLEXcon® family of products.



1 FLEXcon Industrial Park • Spencer, MA 01562-2642 USA
Telephone +1 (508) 885-8296 • www.FLEXcon.com