

# Keysight DCA Sampling Oscilloscopes

Keysight sampling oscilloscopes are now offered in three classes. Modular sampling oscilloscopes include the DCA-X modular sampling oscilloscope mainframe and DCA-X Series modules. SX2-class fixed configuration oscilloscopes include our DCA-M Series sampling oscilloscopes. SX1-class clock recovery products include our DCA-M Series clock data recovery (CDR) units.



## Table of Contents

Legend .....	3
N1000A DCA-X Wide-Bandwidth Oscilloscope Mainframe .....	4
N1002xxxA FlexOTO (Flexible Optical Test Optimization) Solutions .....	6
N1032A/B 90/120 GHz Single/Dual Channel Optical Mini-Module.....	8
N1030A/B 65 GHz Single/Dual Channel Optical Mini-Module.....	10
N1040A 33/60 GHz Dual Channel Electrical Mini-Module.....	12
N1045B 60 GHz 2/4 Port Electrical Remote Sampling Head Module .....	14
N1046A 75/85/100 GHz 1/2/4 Port Electrical Remote Sampling Head Module .....	16
N1055A 35/50 GHz 2/4 Port TDR/TDT Remote Sampling Head Module .....	18
N1060A 50/85 GHz Precision Waveform Analyzer .....	20
N1076B 64 GBd Electrical Clock Recovery .....	22
N1077B 64 GBd Multimode/Single-mode Optical/Electrical Clock Recovery.....	24
N1078A 64 GBd Single-Mode Optical/Electrical Clock Recovery .....	26
N1090A DCA-M Sampling Oscilloscope.....	28
N1092A/B/C/D/E 1/2/3/4 Channel Optical DCA-M Sampling Oscilloscope.....	30
N1093A/B 1/2 Channel Optical DCA-M Sampling Oscilloscope.....	32
N1094A/B 2/4 Channel Electrical DCA-M Sampling Oscilloscope .....	35
N1096A/B 1/2 Channel Optical DCA-M Sampling Oscilloscope.....	37
N1010x00A Analysis Packages .....	39
Appendix .....	40
Application software .....	40
Common DCA accessories .....	41
DCA input connectors .....	42
RF/Microwave connectors.....	43
DCA Upgrades .....	44
Literature References.....	46
Web Resources.....	46

## Legend

The configuration drawings used in this document indicate mandatory features in bold with a dark red background and optional ones in italic with a light gray background. In addition, switches indicate what choices you can make. Figure 1 shows a generic example:

- The product must always have option 1.
- The product must have either option 2 or option 3 or option 4 (always select exactly one). Option 2 is the default or recommended choice.
- The product may or may not have option 5. Option 5 is recommended or selected by default.
- The product may or may not have option 6. Option 6 is not selected by default.
- The product may or may not have option 7 or 8 (if desired then select exactly one). There is no default or recommendation.
- If you want the feature of option 9 then you must first choose option 8.

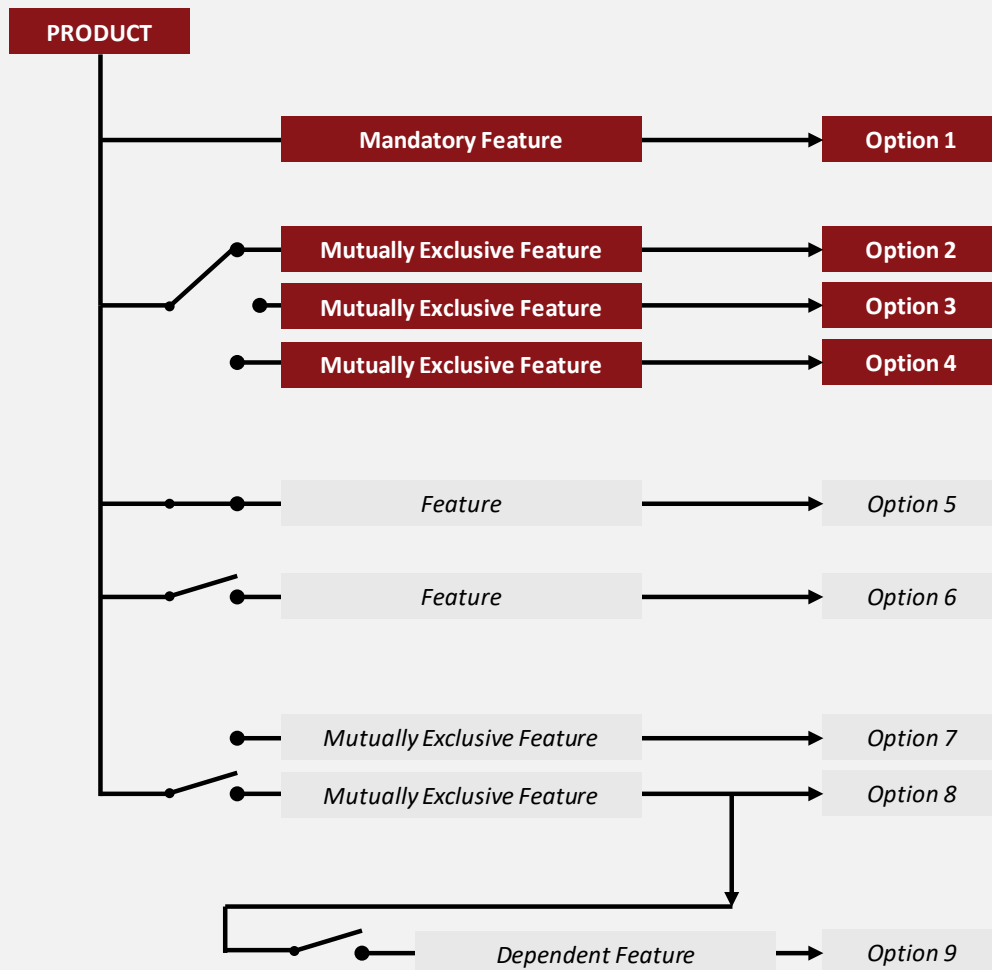

Figure 1. Legend for configuration drawings.

## N1000A DCA-X Wide-Bandwidth Oscilloscope Mainframe

The N1000A DCA-X Wide-Bandwidth Oscilloscope is a modular platform that provides accurate and precise measurements on high-speed digital designs from 50 Mb/s to more than 80 Gb/s. Users configure the N1000A DCA-X mainframe by selecting from a variety of plug-in modules that perform precision optical, electrical, and TDR/TDT measurements. Select specific modules to obtain the desired bandwidth, filtering, and sensitivity that match your measurement needs.

- Flexible, modular platform
- Precision measurements on high-speed signals
- Powerful analysis features

Product/option	Description
N1000A	DCA-X Wide-bandwidth oscilloscope mainframe
N1000A-STB	Standard timebase
N1000A-LOJ	Low jitter timebase
N1000A-PTB	Internal precision timebase (requires # LOJ)
N1000A-PLK	Pattern lock trigger hardware
N1000A-GPI	GPIB card interface
N1000A-C0C	Certificate of calibration
N1000A-UK6	Commercial calibration certificate with test data
N1010100A	R&D package for FlexDCA (requires pattern lock capability)
N1010200A	Manufacturing package for FlexDCA (requires pattern lock capability)
N1010300A	Signal integrity package for FlexDCA



Figure 2. N1000A DCA-X mainframe (without option PTB)

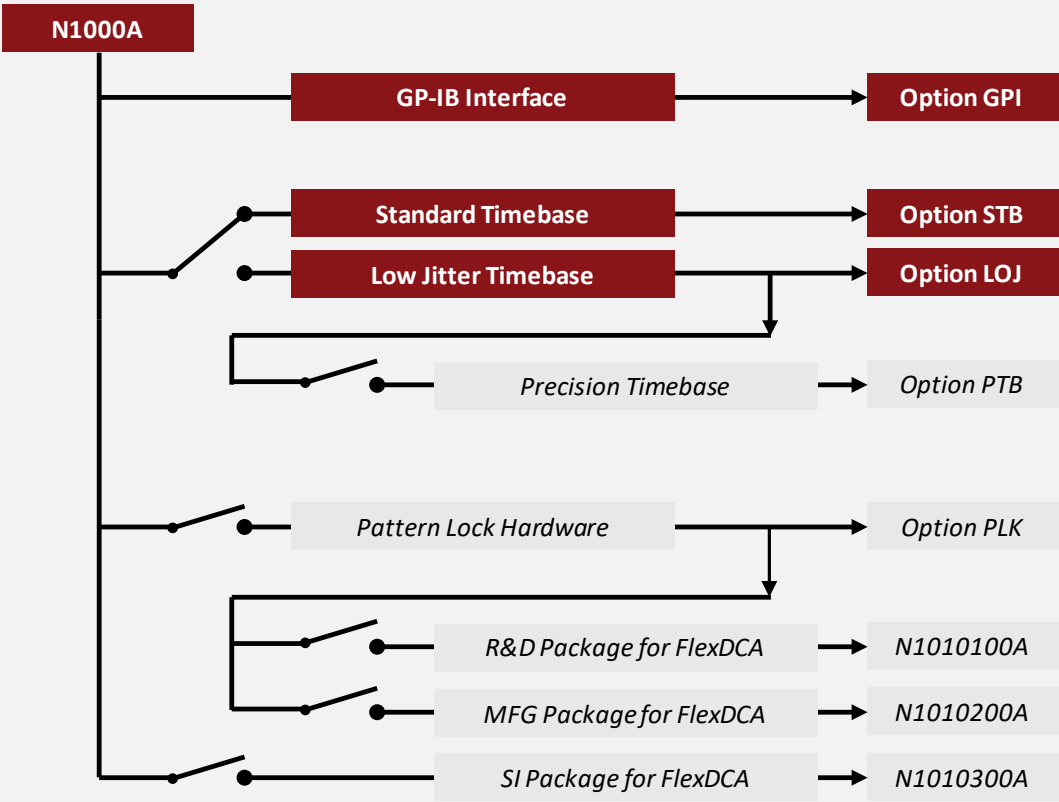

Figure 3. N1000A configuration chart

## N1002xxxA FlexOTO (Flexible Optical Test Optimization) Solutions

FlexOTO (Flexible Optical Test Optimization) application software optimizes optical test efficiency with DCA-M sampling oscilloscopes, such as the N1092x/93x DCA-M and the N1077B/78A Optical/Electrical Clock Recovery module. By automating control of Keysight DCA-M instruments, FlexDCA software, and optical switches, FlexOTO reduces cost-of-test while preserving the highest level of measurement integrity.

Product/option	Description
N1002000A	FlexOTO Software for Basic Optimization
N1002014A	FlexOTO Software for up to 17 ports
N1002048A	FlexOTO Software for up to 48 ports
N1002128A	FlexOTO Software for up to 128 ports
N1010100A	R&D package for FlexDCA
N1010200A	Manufacturing package for FlexDCA
N1002L31A	FlexOTO Optical Test Optimization Dual 1x4 Bundle (Subscription SW license)
N1002P31A	FlexOTO Optical Test Optimization Dual 1x4 Bundle (Perpetual SW license)
N1002L33A	FlexOTO Optical Test Optimization 1x16 Bundle (Subscription SW license)
N1002P33A	FlexOTO Optical Test Optimization 1x16 Bundle (Perpetual SW license)

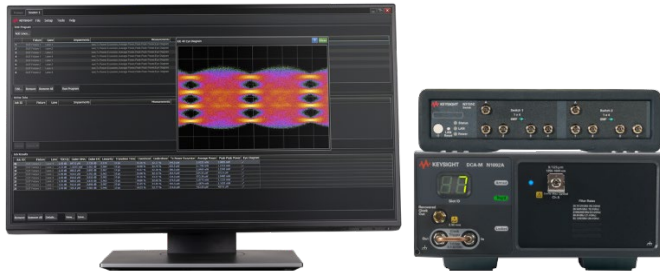

Figure 4. N1002P31A FlexOTO Optical Test Optimization Dual 1x4 Bundle (Perpetual SW license)

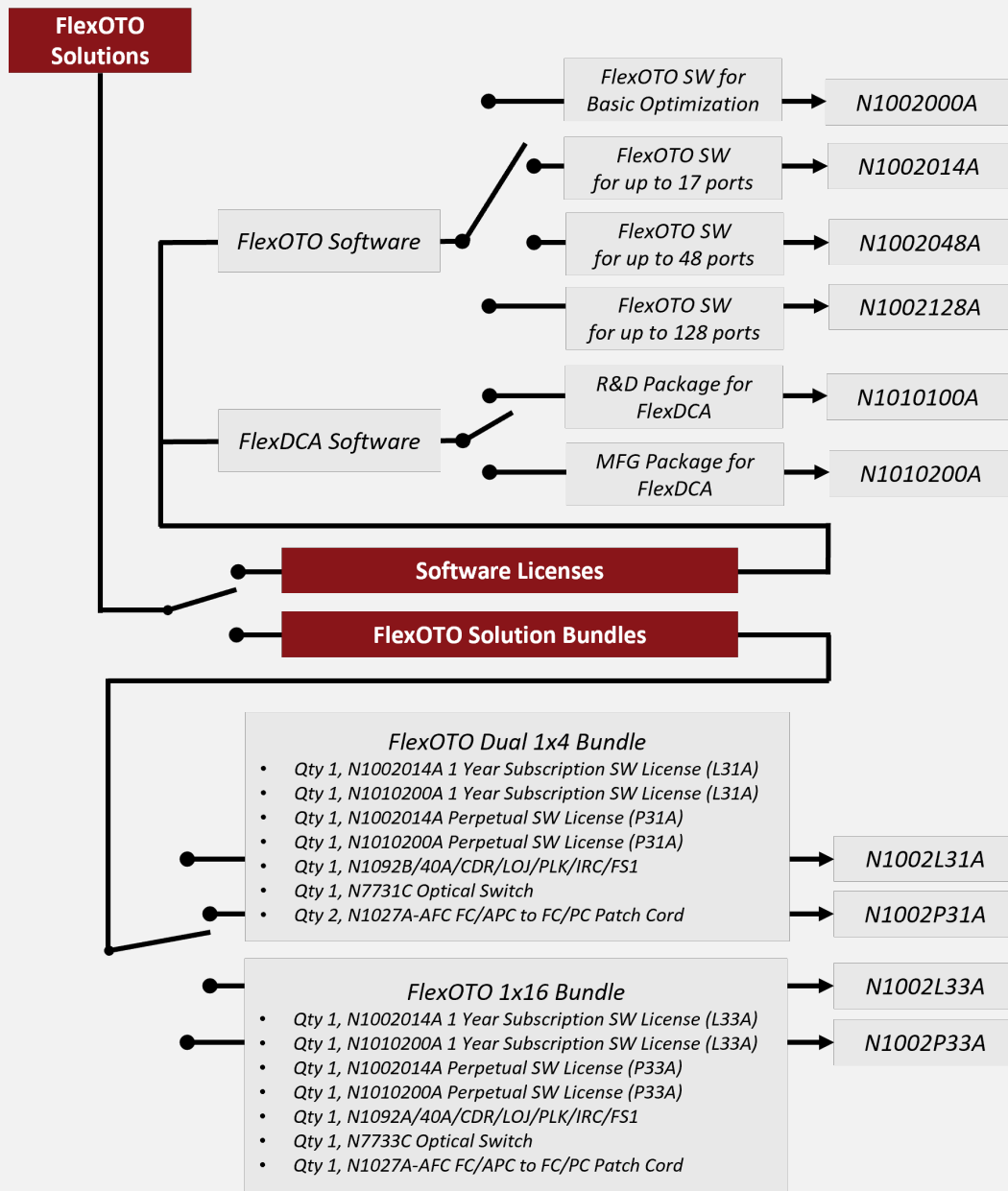

Figure 5. FlexOTO configuration chart

## N1032A/B 90/120 GHz Single/Dual Channel Optical Mini-Module

The N1032A/B are unamplified mini-modules that provide:

- Up to 120 GHz optical bandwidth
- 1 to 8 channels per mainframe
- Ideal for analyzing 112 GBd (224 Gbps) optical signals or any application that require ultra-wide optical receiver > 65 GHz bandwidth (-3 dBo)
- Impulse response correction (Option IRC) is a standard feature and hardware filters for standards-based rates are optional
- Maximum sampling rate:
  - In 86100D mainframe: 40 kSa/s
  - In N1000A mainframe: 250 kSa/s

Product/option	Description
N1032A	Single optical channel module
N1032A-09U	90 GHz Unamplified Optical Channel
N1032A-13U	120 GHz Unamplified Optical Channel
N1032A-112	Hardware filters for Standards-based rates
N1032A-IRC	Impulse response correction

Product/option	Description
N1032B	Dual optical channel module
N1032B-09U	90 GHz Unamplified Optical Channel
N1032B-13U	120 GHz Unamplified Optical Channel
N1032B-112	Hardware filters for Standards-based rates
N1032B-IRC	Impulse response correction



Figure 6. N1032A, N1032B mini-modules

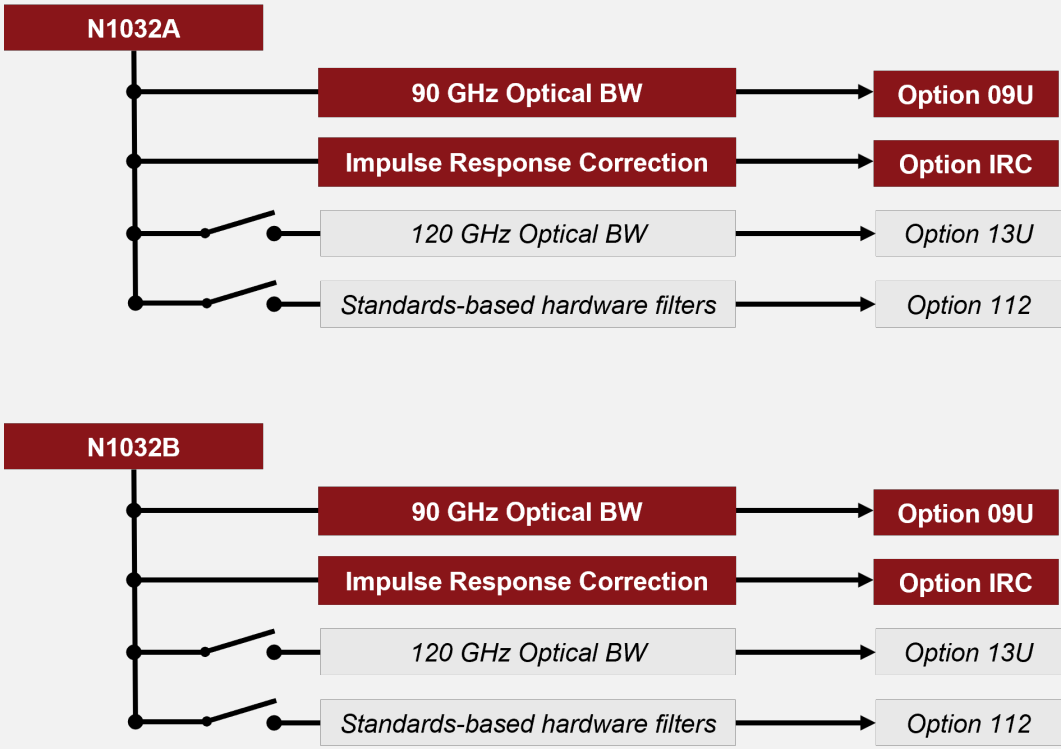

Figure 7. N1032A/B configuration chart

## N1030A/B 65 GHz Single/Dual Channel Optical Mini-Module

The N1030A/B are unamplified mini-modules that provide:

- 65 GHz optical bandwidth
- Optional electrical channel (N1030A only) with 33/40/50/70/85/95 GHz BW settings
- 1 to 8 channels per mainframe
- Simultaneous data acquisition on all channels
- Impulse response correction on all channels (optical and electrical)
- Maximum sampling rate:
  - In 86100D mainframe: 40 kSa/s
  - In N1000A mainframe: 250 kSa/s

Product/option	Description
N1030A	Single optical channel module
N1030A-280	Hardware filters for 25-28 NRZ Gbaud rates
N1030A-490	Hardware filter for 49.77 Gbaud ITU-T G.hsp (PON) rate
N1030A-560	Hardware filters for 53-56 Gbaud rates
N1030A-65U	65 GHz unamplified optical channel
N1030A-EC1	Add 95 GHz single electrical channel
N1030A-IRC	Impulse response correction (optical and electrical channels)

Product/option	Description
N1030B	Dual optical channel module
N1030B-280	Hardware filters for 25-28 NRZ Gbaud rates
N1030B-490	Hardware filter for 49.77 Gbaud ITU-T G.hsp (PON) rate
N1030B-560	Hardware filters for 53-56 Gbaud rates
N1030B-65U	65 GHz unamplified optical channel
N1030B-IRC	Impulse response correction



Figure 8. N1030A, N1030A with option EC1, N1030B mini-modules

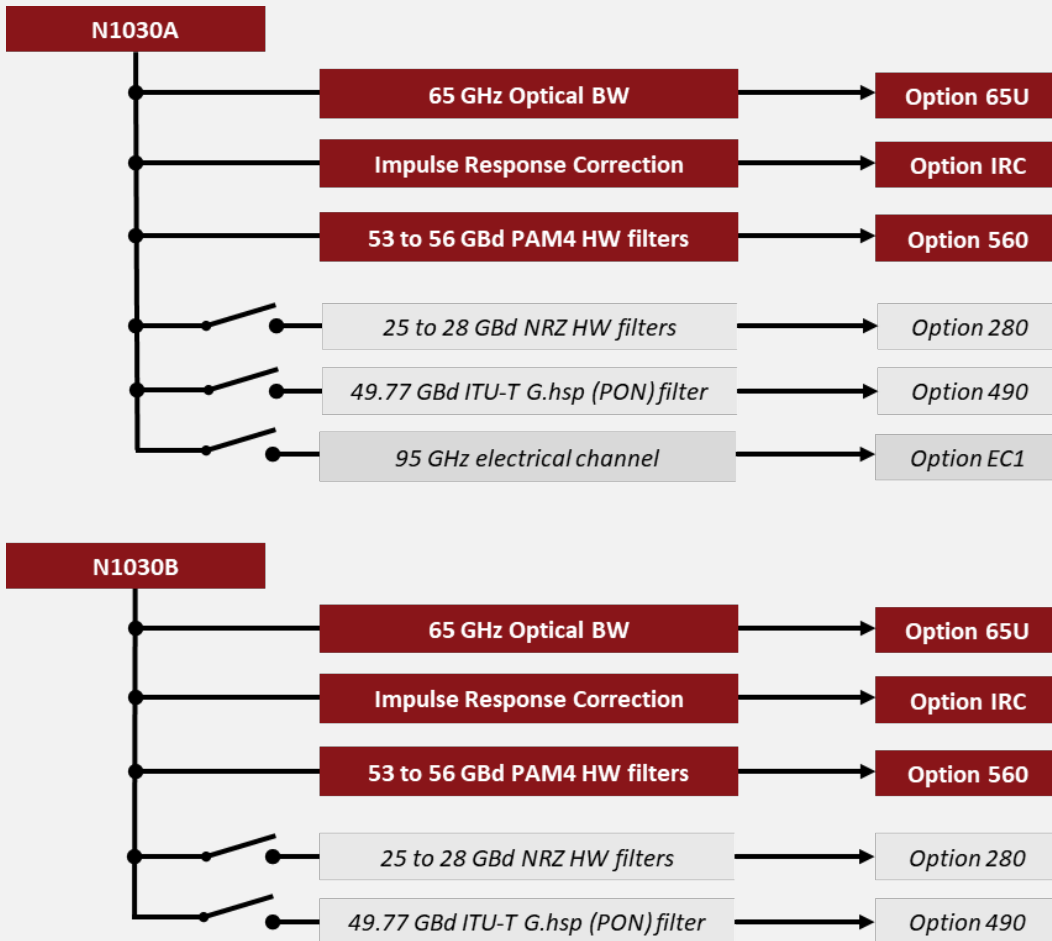

Figure 9. N1030A/B configuration chart

## N1040A 33/60 GHz Dual Channel Electrical Mini-Module

The N1040A electrical mini-module provides two electrical channels.

- 20 to 60 GHz bandwidth settings
- Independent skew control for each channel
- 2 to 8 channels per mainframe
- Simultaneous data acquisition on all channels
- Impulse response correction
- Maximum sampling rate:
  - In 86100D mainframe: 40 kSa/s
  - In N1000A mainframe: 250 kSa/s

Product/option	Description
N1040A	Dual electrical channel module
N1040A-033	20/33 GHz bandwidth, 2.92 mm inputs
N1040A-060	20/33/40/60 GHz bandwidth, 1.85 mm inputs
N1040A-IRC	Impulse response correction



Figure 10. N1040A mini-module

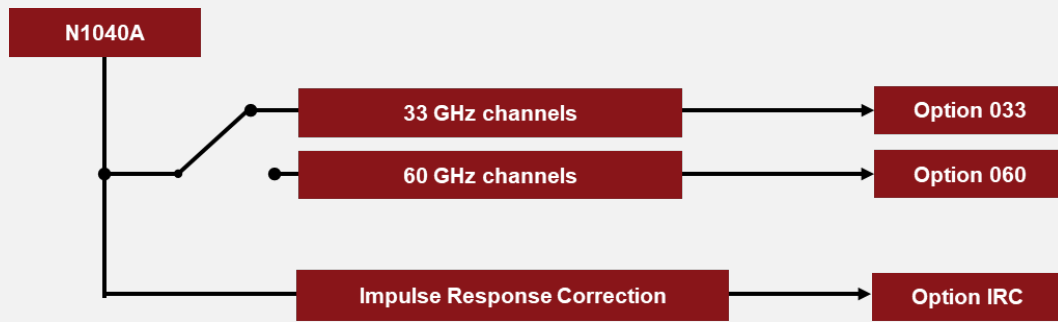

Figure 11. N1040A configuration chart

## N1045B 60 GHz 2/4 Port Electrical Remote Sampling Head Module

The N1045B 60 GHz remote sampling head module is engineered to provide superior measurement accuracy with the highest throughput for testing multi-lane electrical designs. The remote head design allows the high-bandwidth sampler to be located very near the device under test which minimizes loss due to cabling.

- 60 GHz bandwidth (65 GHz typical)
- Independent skew control on each sampler
- 2 to 16 electrical channels per mainframe
- Simultaneous data acquisition on all channels
- Maximum sampling rate:
  - In 86100D mainframe: 40 kSa/s
  - In N1000A mainframe: 250 kSa/s

Product/option	Description
N1045B	60 GHz 2/4 port electrical remote sampling head
N1045B-02F	2 channel remote head, 1.85 mm, female inputs
N1045B-02M	2 channel remote head, 1.85 mm, male inputs
N1045B-04F	4 channel remote head, 1.85 mm, female inputs
N1045B-04M	4 channel remote head, 1.85 mm, male inputs
N1045B-C0C	Certificate of calibration
N1045B-UK6	Commercial calibration certificate with test data
N1027A-45A	Accessory kit for two N1045A/N1045B channels



Figure 12. N1045B 60 GHz remote head module with option 04M

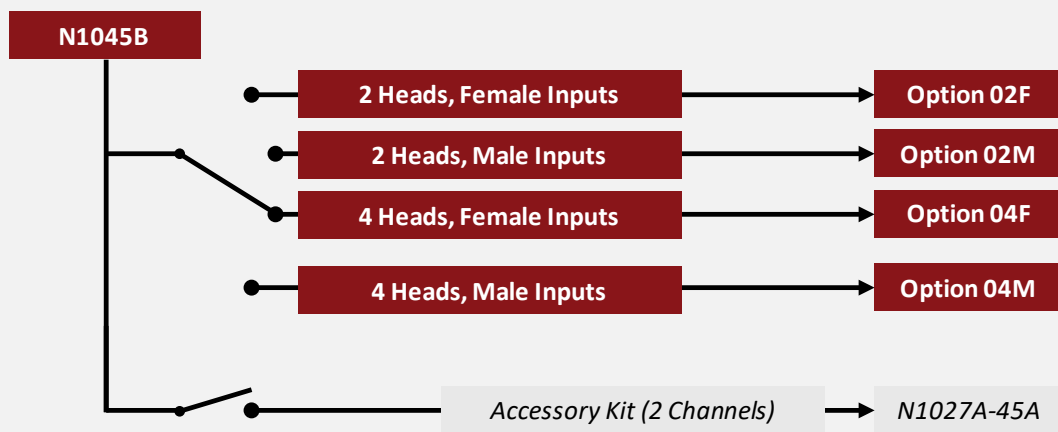

Figure 13. N1045B configuration chart

## N1046A 75/85/100 GHz 1/2/4 Port Electrical Remote Sampling Head Module

The N1046A is a group of remote sampling head modules designed for the fastest oscilloscope applications. The “soft roll-off” of their frequency response can capture wideband digital signals such as NRZ or PAM4, as well as narrowband.

- 75 GHz, 85 GHz or > 100 GHz maximum available bandwidth (selectable option, upgradable)
- 1, 2 or 4 channels per module
- 1 to 4 modules per mainframe
- Independent skew control on each sampler
- Simultaneous data acquisition on all channels
- User-selectable bandwidth settings starting at 60 GHz
- Maximum sampling rate:
  - In 86100D mainframe: 40 kSa/s
  - In N1000A mainframe: 250 kSa/s <sup>1</sup>

Product/option	Description
N1046A	75/85/100 GHz 1/2/4 Port Electrical Remote Sampling Head <sup>2</sup>
N1046A-11F	100 GHz, 1 channel remote head, 1 mm, female
N1046A-12F	100 GHz, 2 channel remote head, 1 mm, female
N1046A-14F	100 GHz, 4 channel remote head, 1 mm, female
N1046A-71F	75 GHz, 1 channel remote head, 1 mm, female
N1046A-72F	75 GHz, 2 channel remote head, 1 mm, female
N1046A-74F	75 GHz, 4 channel remote head, 1 mm, female
N1046A-81F	85 GHz, 1 channel remote head, 1 mm, female
N1046A-82F	85 GHz, 2 channel remote head, 1 mm, female
N1046A-84F	85 GHz, 4 channel remote head, 1 mm, female
N1046A-C0C	Certificate of calibration
N1046A-UK6	Commercial calibration certificate with test data
N1027A-46A	Accessory kit for two N1046A channels

<sup>1</sup> Modules with serial number prefix small than US5840 are limited to 40 kSa/s. Keysight will upgrade them to the full sampling rate free of charge during their next calibration cycle.  
<sup>2</sup> Module includes a custom System Impulse Response Correction (SIRC) file for each channel.



Figure 14. N1046A 100 GHz remote head module with option 12F, 1.0 mm input connector detail

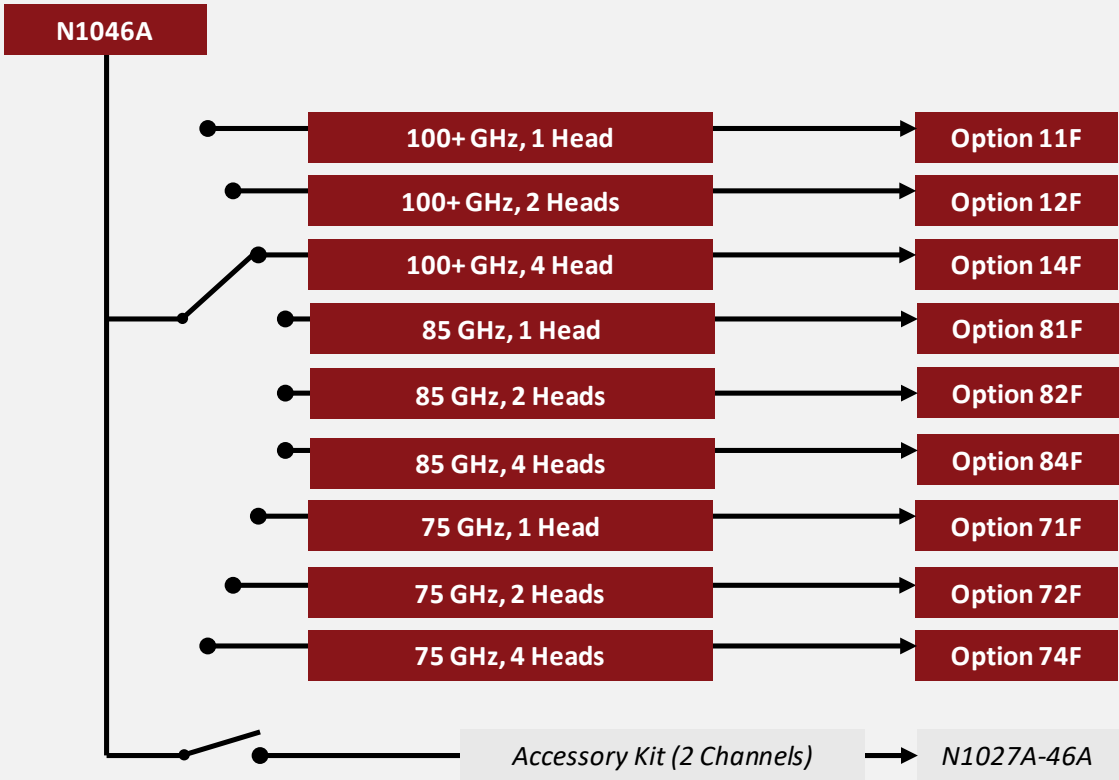

Figure 15. N1046A configuration chart

## N1055A 35/50 GHz 2/4 Port TDR/TDT Remote Sampling Head Module

The Keysight N1055A 35/50-GHz (8-ps) time-domain reflectometry (TDR) and time-domain transmission (TDT) module for the Keysight 86100D DCA-X platform provides fast, accurate impedance and S-parameter measurements on high-speed designs that have up to 16 ports.

- Dual or quad remote heads with either 35 or 50 GHz bandwidth
- Edge speed (10 to 90%, typical): 18 ps (35 GHz) or 8 ps (50 GHz)
- Integrated diode limiters for ESD/EOS protection
- Maximum sampling rate:
  - In 86100D mainframe: 40 kSa/s (200 kSa/s <sup>3</sup> with Option FS1)
  - In N1000A mainframe: 250 kSa/s

Product/option	Description
N1055A	35/50 GHz 2/4 Port electrical remote head module with TDR/TDT
N1055A-32F	35 GHz 2 channels, 2.92 mm, female
N1055A-32M	35 GHz 2 channels, 2.92 mm, male
N1055A-34F	35 GHz 4 channels, 2.92 mm, female
N1055A-34M	35 GHz 4 channels, 2.92 mm, male
N1055A-52F	50 GHz 2 channels, 1.85 mm, female
N1055A-52M	50 GHz 2 channels, 1.85 mm, male
N1055A-54F	50 GHz 4 channels, 1.85 mm, female
N1055A-54M	50 GHz 4 channels, 1.85 mm, male
N1055A-C0C	Certificate of calibration
N1055A-UK6	Commercial calibration certificate with test data
N1055A-FS1	Fast sampling (mandatory on all new shipping units)
N1027A-x4y <sup>4</sup>	TDT/TDT accessory kit with DC to 67 GHz ECal module and adapters
N4694D-0DC	DC to 67 GHz 2-port 1.85 mm ECal module <sup>5</sup>

<sup>3</sup> In TDR mode when only channels from one module are active.

<sup>4</sup> x and y of N1027A option must match the N1055A option (e.g., use N1027A-54F for N1055A-52F/54F).

<sup>5</sup> Use N469xD with option M0M for N1055A-xxF remote heads, and N469xD-F0F for N1055A-xxM.



Figure 16. N1055A 50 GHz TDR/TDT modules with option 54M

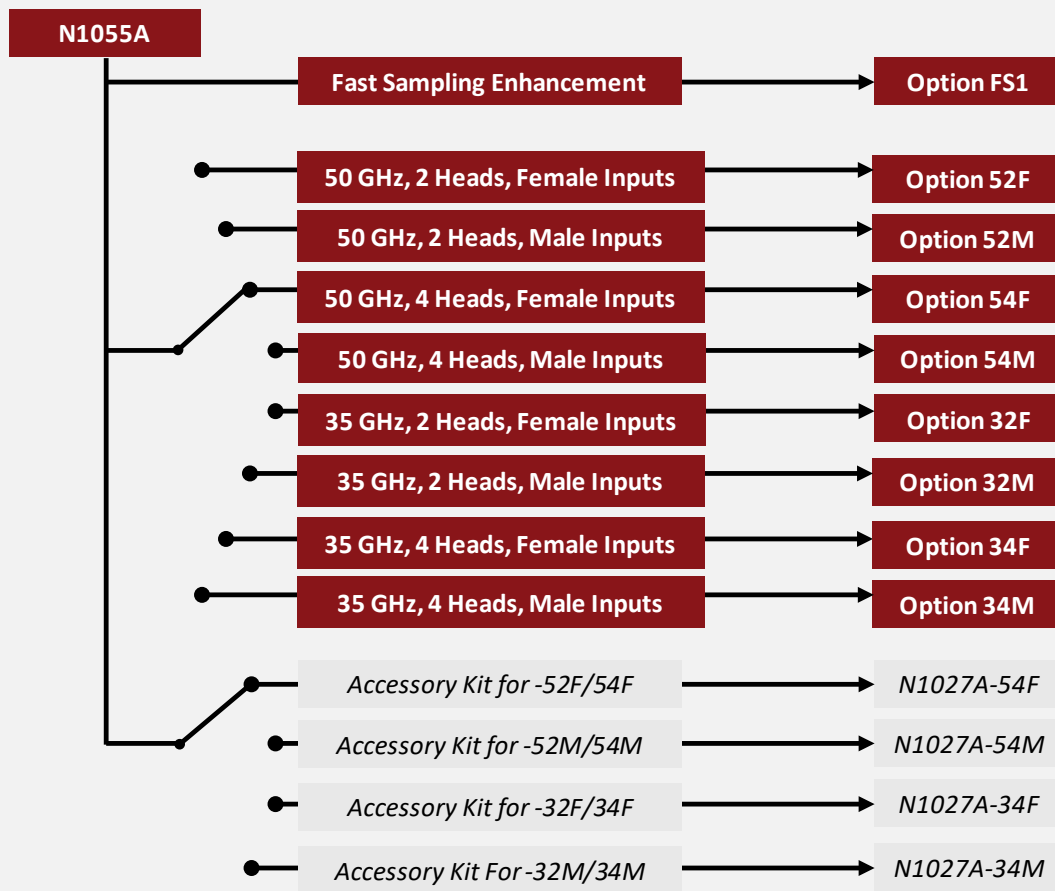

Each accessory kit includes one DC-67 GHz coupled ECal module, adapters, torque wrenches, and more.

Figure 17. N1055A configuration chart

## N1060A 50/85 GHz Precision Waveform Analyzer

The N1060A precision Waveform Analyzer is a three-slot wide module that combines two electrical channels with a clock recovery (CDR) and a precision timebase (PTB). Integration minimizes path delay differences between the CDR, PTB and the samplers, resulting in more accurate jitter measurements.

- 50 or 85 GHz bandwidth
- 16, 32 or 64 GBd NRZ and PAM4 clock recovery
- Jitter Spectrum Analysis and Clock Recovery Emulation
- Electrical inputs: 1.0 mm male
  - Ships with 1.0 female to 1.85 female and 1.0 female to 2.92 female adapters

Product/option	Description
N1060A	Precision waveform analyzer <sup>6</sup>
N1060A-050	Two 50 GHz channels
N1060A-085	Two 85 GHz channels
N1060A-216	Supported input rates: 125 MBd to 16 GBd
N1060A-232	Supported input rates: 125 MBd to 32 GBd
N1060A-264	Supported input rates: 125 MBd to 64 GBd
N1060A-EVA	Integrated variable equalizer
N1060A-JSA	Jitter spectrum analysis
N1060A-PTB	Precision timebase, ultra-low random jitter
N1060A-E33	Integrated hardware filters for 33 GHz, 40 GHz, and 43 GHz
N1060A-C0C	Certificate of calibration
N1060A-UK6	Commercial calibration certificate with test data
N1060A-A1F	Two 1.0 mm female to 1.0 mm female adapters
N1060A-CA1	Cable pair, 1.0 mm
N1060A-CA2	Cable pair (matched), 2.4 mm, 60 cm
N1060A-DC2	Two DC blocks, 2.4 mm, 50 KHz – 50 GHz
N1060A-DC8	Two DC blocks, 1.85 mm, 700 KHz-67 GHz

<sup>6</sup> Module includes a custom System Impulse Response Correction (SIRC) file for each channel.



Figure 18. N1060A Precision waveform analyzer with option 085

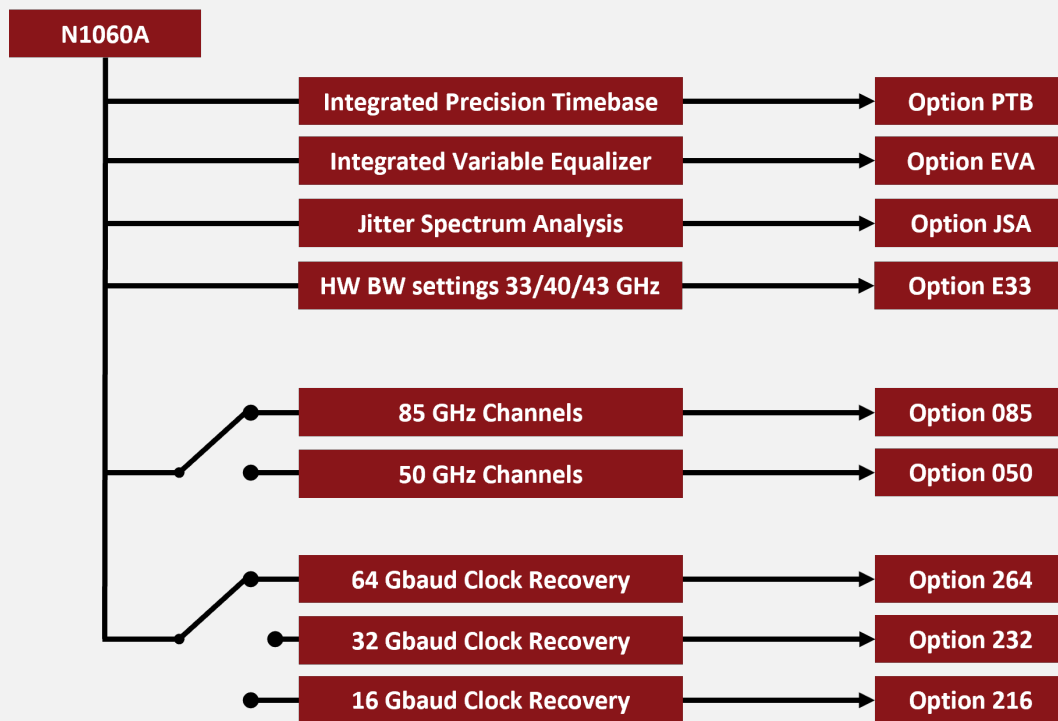

Figure 19. N1060A configuration chart

## N1076B 64 GBd Electrical Clock Recovery

Provides compliant clock recovery capabilities for electrical non-return-to-zero (NRZ) and pulse amplitude modulation 4-level (PAM4) signals

- Continuous unbanded tuning from 125 MBd to 64 GBd PAM4 and NRZ
- Adjustable clock recovery loop bandwidth (to 20 MHz) and peaking for “Golden PLL” performance
- Internal and external equalizers to recover clock from closed eyes
- Ultra-low residual random jitter < 100 fs RMS
- Jitter Spectrum Analysis (JSA)
- Phase noise analysis of clock or data signals using FlexPLL software in N1010300A Signal integrity package
- Controlled by N1010A FlexDCA application (free download) or DCA-X mainframe

Product/option	Description
N1076B	Electrical clock recovery
N1076B-216	Supported input rates: 125 MBd to 16 GBd
N1076B-232	Supported input rates: 125 MBd to 32 GBd
N1076B-264	Supported input rates: 125 MBd to 64 GBd
N1076B-EVA	Integrated variable equalizer
N1076B-C0C	Certificate of calibration
N1076B-UK6	Commercial calibration certificate with test data
N1076B-1CM	Single DCA-M rack mount kit
N1076B-1CN	Dual DCA-M side by side rack mount
N1076B-CR1	Clock recovery phase matching kit
N1076B-2P1	Microwave pick-off tee 1.0 mm connectors, matched pair
N1076B-2P2	Microwave pick-off tee 2.4 mm connectors, matched pair
N1076B-2P3	Microwave pick-off tee 2.92 mm connectors, matched pair
N1076B-2P8	Microwave pick-off tee 1.85 mm connectors, matched pair
JSA	Jitter spectrum analysis will be enabled by N1010100A or N1010300A



Figure 20. N1076B Electrical clock recovery with option 264

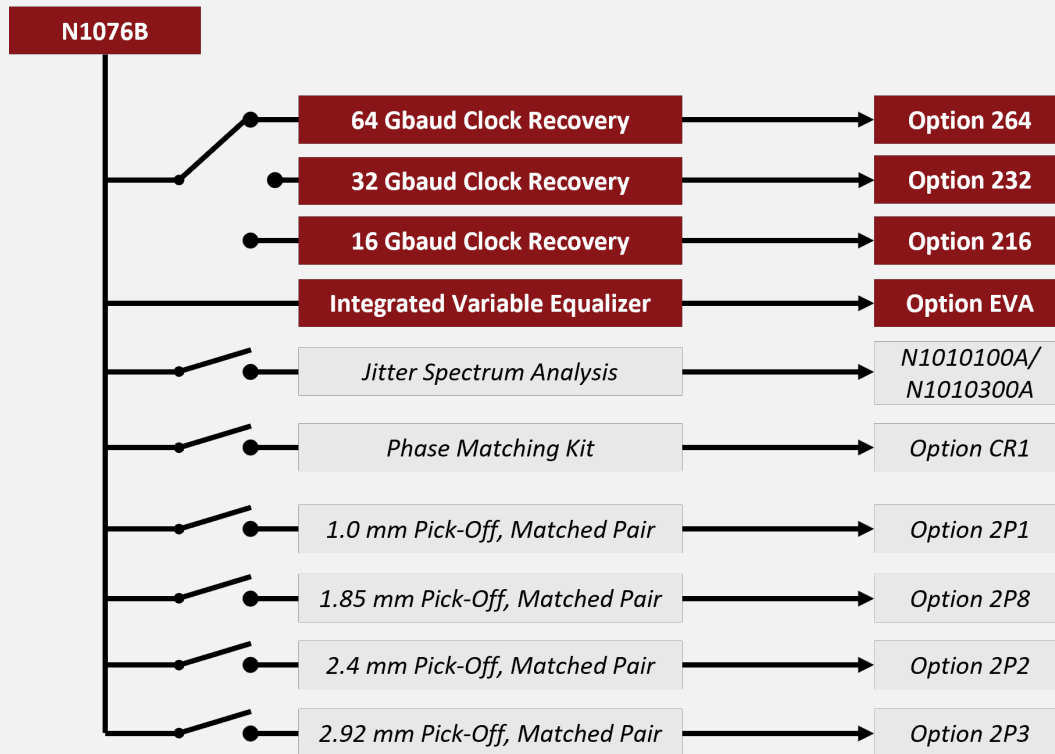

The pick-offs have 2.92 mm connectors on the clock recovery port. The other two ports are male and female with connector sizes as shown above.

Figure 21. N1076B configuration chart

## N1077B 64 GBd Multimode/Single-mode Optical/Electrical Clock Recovery

Provides compliant clock recovery capabilities for multimode and single-mode optical as well as electrical signals

- Works with non-return-to-zero (NRZ) and pulse amplitude modulation 4-level (PAM4) modulation
- Continuous unbanded tuning from 125 MBd to 64 GBd PAM4 and NRZ
- Adjustable clock recovery loop bandwidth (to 20 MHz) and peaking for “Golden PLL” performance
- Internal and external equalizers to recover clock from closed eyes
- Ultra-low residual random jitter < 100 fs RMS
- Jitter Spectrum Analysis (JSA)
- Phase noise analysis of clock or data signals using FlexPLL software in N1010300A Signal integrity package
- Controlled by N1010A FlexDCA application (free download) or DCA-X mainframe

Product/option	Description
N1077B	Optical/electrical clock recovery <sup>7</sup>
N1077B-216	Supported input rates: 125 MBd to 16 GBd
N1077B-225	Supported input rates 24 GBd to 29 GBd
N1077B-232	Supported input rates: 125 MBd to 32 GBd
N1077B-253	Supported input rates 48 GBd to 58 GBd
N1077B-264	Supported input rates: 125 MBd to 64 GBd
N1077B-SMM	Internal 70/30 splitter
N1077B-SXT	No splitter (splitter supplied by user)
N1077B-EVA	Integrated variable equalizer
N1077B-C0C	Certificate of calibration
N1077B-UK6	Commercial calibration certificate with test data
N1077B-CR1	Clock recovery phase matching kit
JSA	Jitter spectrum analysis will be enabled by N1010100A or N1010300A

<sup>7</sup> Clock Pattern Distortion Compensation feature must be enabled for single-mode wavelength.



Figure 24. N1077B Multimode/Single-mode optical/electrical clock recovery with options 264 and SMM

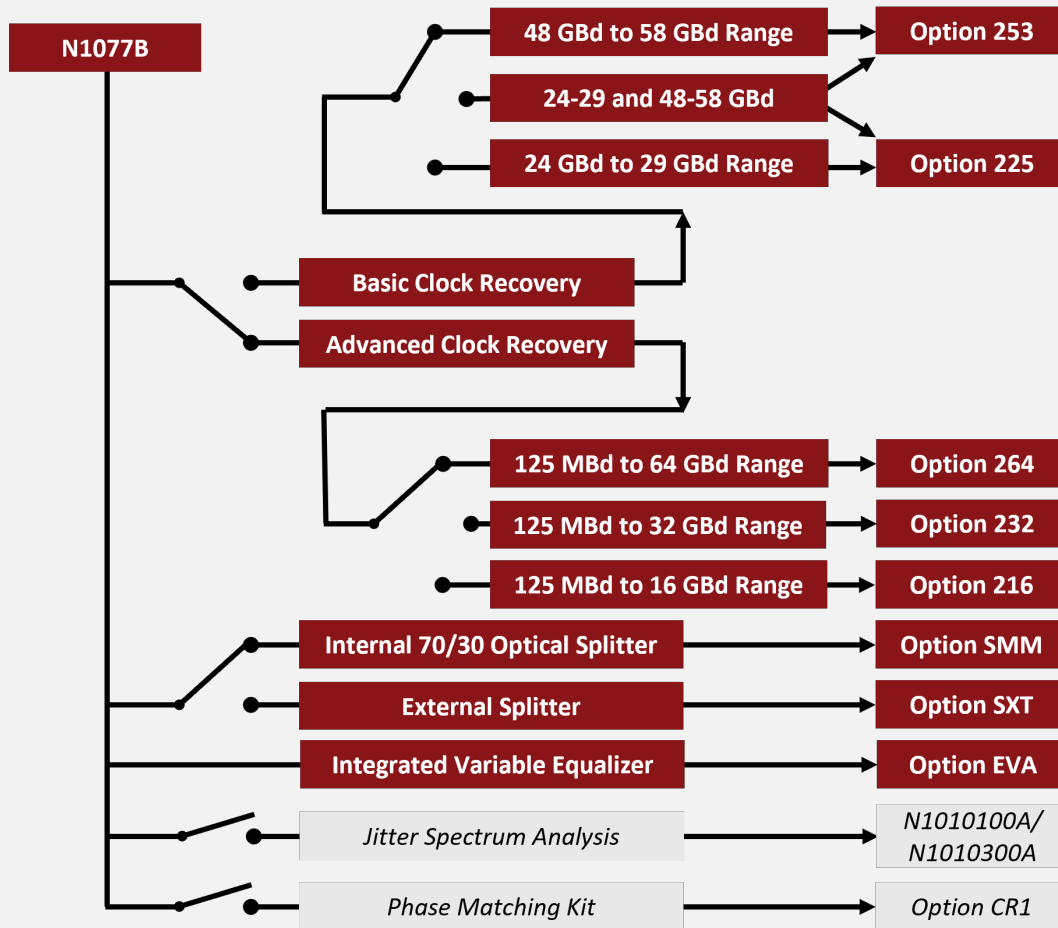

External splitters must be supplied by the customer.

Figure 25. N1078A configuration chart

## N1078A 64 GBd Single-Mode Optical/Electrical Clock Recovery

Provides compliant clock recovery capabilities for single-mode optical as well as electrical signals

- Works with non-return-to-zero (NRZ) and pulse amplitude modulation 4-level (PAM4) modulation
- Continuous unbanded tuning from 125 MBd to 64 GBd PAM4 and NRZ
- Adjustable clock recovery loop bandwidth (to 20 MHz) and peaking for “Golden PLL” performance
- Internal and external equalizers to recover clock from closed eyes
- Ultra-low residual random jitter < 100 fs RMS
- Jitter Spectrum Analysis (JSA)
- Phase noise analysis of clock or data signals using FlexPLL software in N1010300A Signal integrity package
- Controlled by N1010A FlexDCA application (free download) or DCA-X mainframe

Product/option	Description
N1078A	Optical/electrical clock recovery
N1078A-216	Supported input rates: 125 MBd to 16 GBd
N1078A-225	Supported input rates 25 GBd to 29 GBd
N1078A-232	Supported input rates: 125 MBd to 32 GBd
N1078A-253	Supported input rates 53 GBd to 58 GBd
N1078A-264	Supported input rates: 125 MBd to 64 GBd
N1078A-S50	Internal 50-50 SM optical splitter
N1078A-SXT	No splitter (splitter supplied by user)
N1078A-EVA	Integrated variable equalizer
N1078A-C0C	Certificate of calibration
N1078A-UK6	Commercial calibration certificate with test data
N1078A-CR1	Clock recovery phase matching kit
JSA	Jitter spectrum analysis will be enabled by N1010100A or N1010300A



Figure 26. N1078A Single-mode optical/electrical clock recovery with options 264 and S50

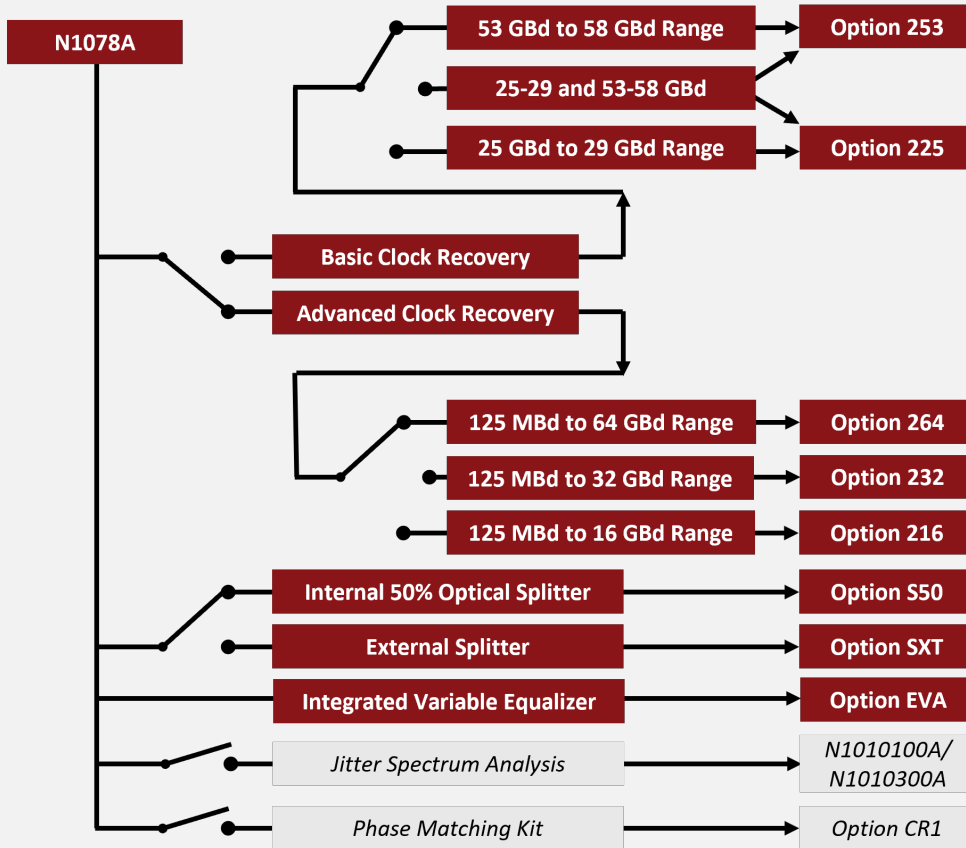

External splitters must be supplied by the customer.

Figure 27. N1078A configuration chart

## N1090A DCA-M Sampling Oscilloscope

High accuracy, low-cost solutions for 1.25 Gb/s to 11.3 Gb/s optical and electrical waveform analysis

- 750 to 1650 nm, single-mode and multimode
- High-sensitivity optical channel with noise <1  $\mu$ W
- Optical reference receivers meet industry specifications for verifying compliance to standards
- Maximum sampling rate: 60 kSa/s
- Controlled by N1010A FlexDCA application (free download) or DCA-X mainframe

Product/option	Description
N1090A	Optical sampling oscilloscope
N1090A-140	Reference receiver filters for 1.244/1.25/1.229 Gb/s
N1090A-160	Reference receiver filters for 2.458/2.488/2.5 Gb/s
N1090A-200	Reference receiver filters for 8.5/9.95/10.3/10.5/10.66/10.71/11.1/11.3 Gb/s
N1090A-204	Reference receiver filters for 8.5/9.95/10.3/10.5 Gb/s
N1090A-EEC	Add 20 GHz electrical channel
N1090A-PLK	Pattern lock trigger hardware
N1090A-IRC	Impulse response correction (optical channels only)
N1090A-C0C	Certificate of calibration
N1090A-UK6	Commercial calibration certificate with test data
N1090A-1CM	Single N1090A rack mount kit
N1090A-1CN	Dual instrument side by side rack mount kit
N1010100A	R&D package for FlexDCA (requires pattern lock capability)
N1010200A	Manufacturing package for FlexDCA (requires pattern lock capability)



Figure 28. N1090A DCA-M (without option EEC)

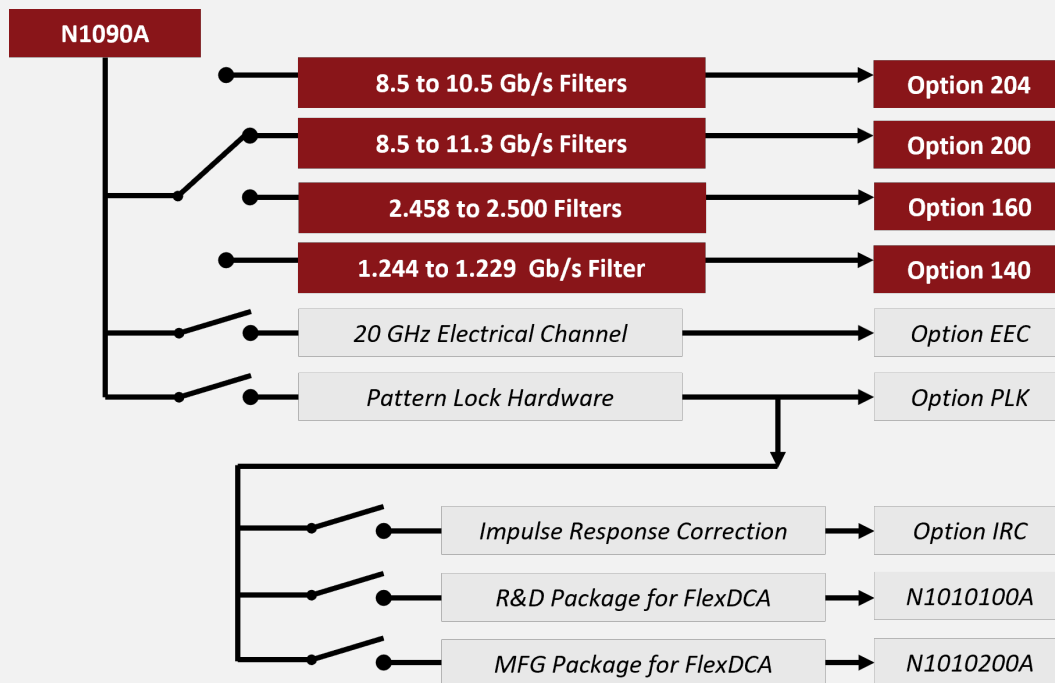

Figure 29. N1090A configuration chart

## N1092A/B/C/D/E 1/2/3/4 Channel Optical DCA-M Sampling Oscilloscope

A high-sensitivity solution with flexible configuration options, enabling 8.4 GBd to 64 GBd optical and electrical waveform analysis.

- 830 to 1600 nm, single-mode and multimode
- 50 GHz electrical channels (N1092C/E)
- Characteristic intrinsic jitter: 400 fs (standard), 160 fs (Option LOJ)
- Maximum sampling rate: 100 kSa/s (standard), 250 kSa/s (Option FS1)
- Controlled by N1010A FlexDCA software (free download) or DCA-X mainframe

Product/option	Description
N1092A/B/D	Single/dual/quad optical channel oscilloscope
N1092C/E	Single/dual optical, dual electrical channel oscilloscope
N1092x-280	25.781, 26.563, 27.952, 28.050 Gbaud filters (mandatory)
N1092x-30A	30 GHz amplified SM/MM optical
N1092A-N28	30 GHz amplified SM/MM optical, 280 kHz high-pass
N1092x-40A	40 GHz amplified SM optical and additional 53.125 GBd hardware filter
N1092x-CDR	Add 24-29 and 48-58 GBd Clock Recovery (N1092A/B models only, requires #40A)
N1092x-CRX	Extended clock recovery input rates: 125 MBd to 64 GBd (requires #40A and #CDR)
N1092x-168	Add 25.78 Gb/s TDEC filter (only for #30A)
N1092x-206	Add 20.625 Gb/s filter (only for #30A)
N1092x-STB	Standard timebase
N1092x-LOJ	Low jitter timebase
N1092x-PLK	Pattern lock trigger hardware (requires Option LOJ)
N1092x-FS1	Fast sampling rate
N1092x-IRC	Impulse response correction (optical channels only)
N1092x-C0C	Certificate of calibration
N1092x-UK6	Commercial calibration certificate with test data
N1092x-1CM	Single instrument rack mount kit
N1092x-1CN	Dual instrument side by side rack mount kit
N1010100A	R&D package for FlexDCA (requires options PLK and LOJ)
N1010200A	Manufacturing package for FlexDCA (requires Options PLK and LOJ)
JSA for #CDR	Jitter spectrum analysis will be enabled by N1010100A or N1010300A



Figure 30. N1092D quad optical DCA-M with 30A, 280, and 168 options

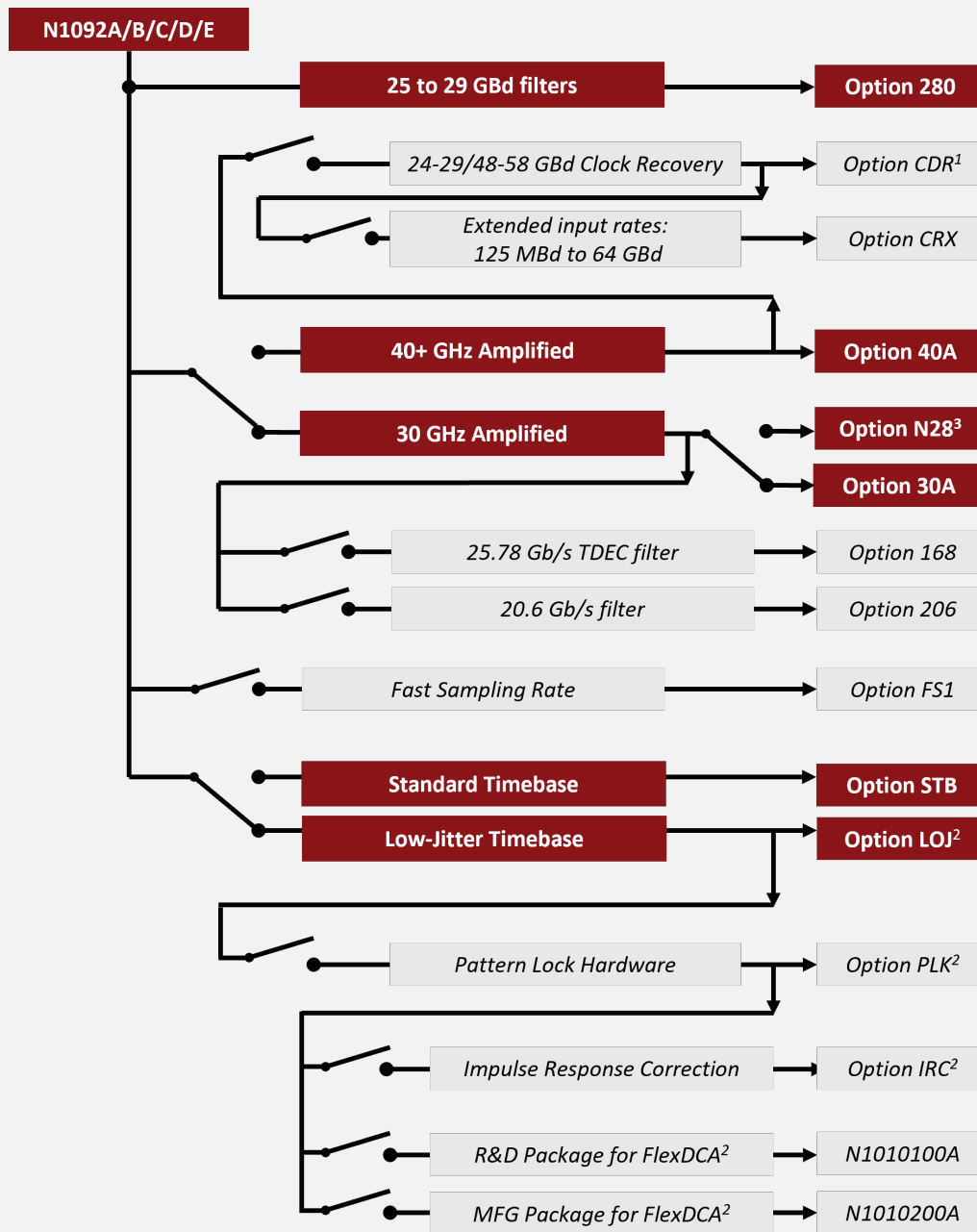

Figure 31. N1092A/B/C/D/E configuration chart

1. Option CDR is available only on the N1092A and N1092B.
2. TDECQ measurements require options LOJ, PLK, IRC and the R&D or MFG package. See document 5992-3635EN for TDECQ measurement details.
3. Option N28 with 50 Hz – 280 kHz notch filter is available only on the N1092A.

## N1093A/B 1/2 Channel Optical DCA-M Sampling Oscilloscope

224G high-sensitivity optical channels with integrated clock recovery up to 120 GBd for optical waveform and jitter measurements enabling more reliable 1.6T AI networks.

- 1250 to 1350 nm, Single-Mode
- Optical bandwidth 60 GHz with System Impulse Response Correction (SIRC) enabled
- High sensitivity optical channel with < 15  $\mu$ W noise
- Accurate high data-rate jitter analysis with 105 fs intrinsic jitter (LOJ: 160 fs, PTB: 105 fs)
- Integrated clock recovery up to 120 GBd available (option CDR and CRX)
- N1093BB0xA bundles offer quad-channel scalability at an affordable price, enabling higher throughput and drive down production costs.
- Controlled by N1010A FlexDCA software (free download) or DCA-X mainframe

Product/option	Description
N1093A/B	Single/dual optical channel oscilloscope
N1093x-CDR	Integrated Clock Recovery, Standard range 52-57.75 GBd and 104-115.5 GBd
N1093x-CRX	Extended Clock Recovery Range, 48-58 GBd and 88-120 GBd
N1093x-LOJ	Low jitter timebase
N1093x-PTB	Integrated Precision Timebase
N1093x-PLK	Pattern lock trigger hardware
N1093x-FS1	Fast sampling rate
N1093x-IRC	Impulse response correction
N1093B-MFG <sup>8</sup>	N1093BB MFG Bundle unit
N1093x-C0C	Certificate of calibration
N1093x-UK6	Commercial calibration certificate with test data
N1093BB01A	Quad Channel DCA-M Bundle of two N1093Bs One with CDR
N1093BB02A	Quad Channel DCA-M Bundle of two N1093Bs with No CDR
N1093BB03A	Quad Channel DCA-M Bundle of two N1093Bs Both with CDR
1CM124A	Single DCA-M Rack Mount Kit
1CN118A	Dual DCA-M side by side rack mount
N1010100A	R&D package for FlexDCA
N1010200A	Manufacturing package for FlexDCA

<sup>8</sup> Option MFG is included on all N1093B units in N1093BB01A/02A/03A bundles and cannot be upgraded.



Figure 32. N1093B dual optical DCA-M with CDR, and PTB options

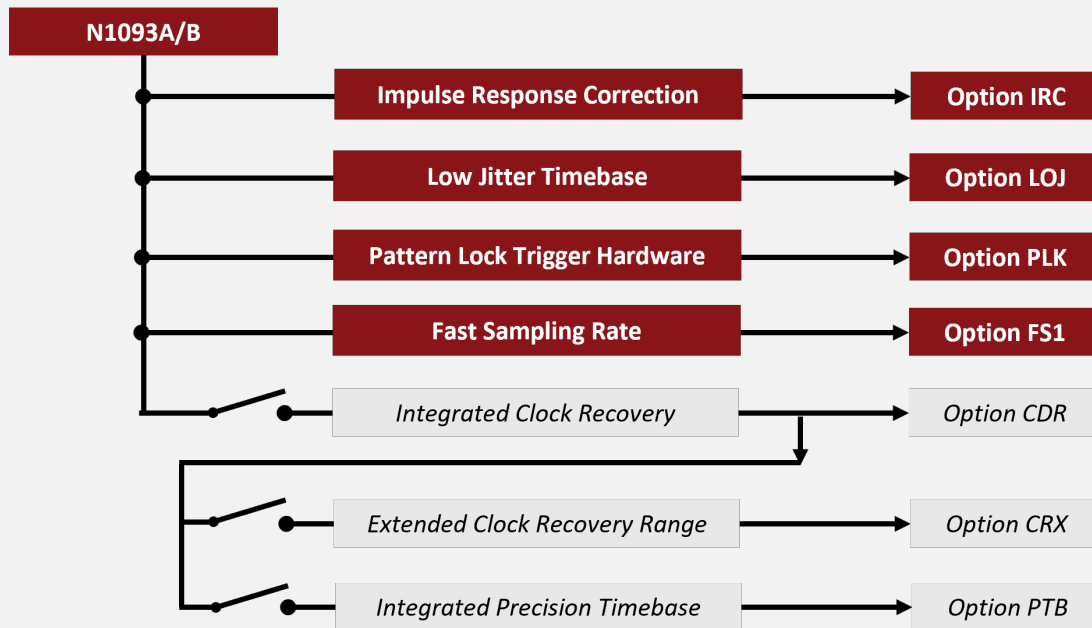

Figure 33. N1093A/B configuration chart

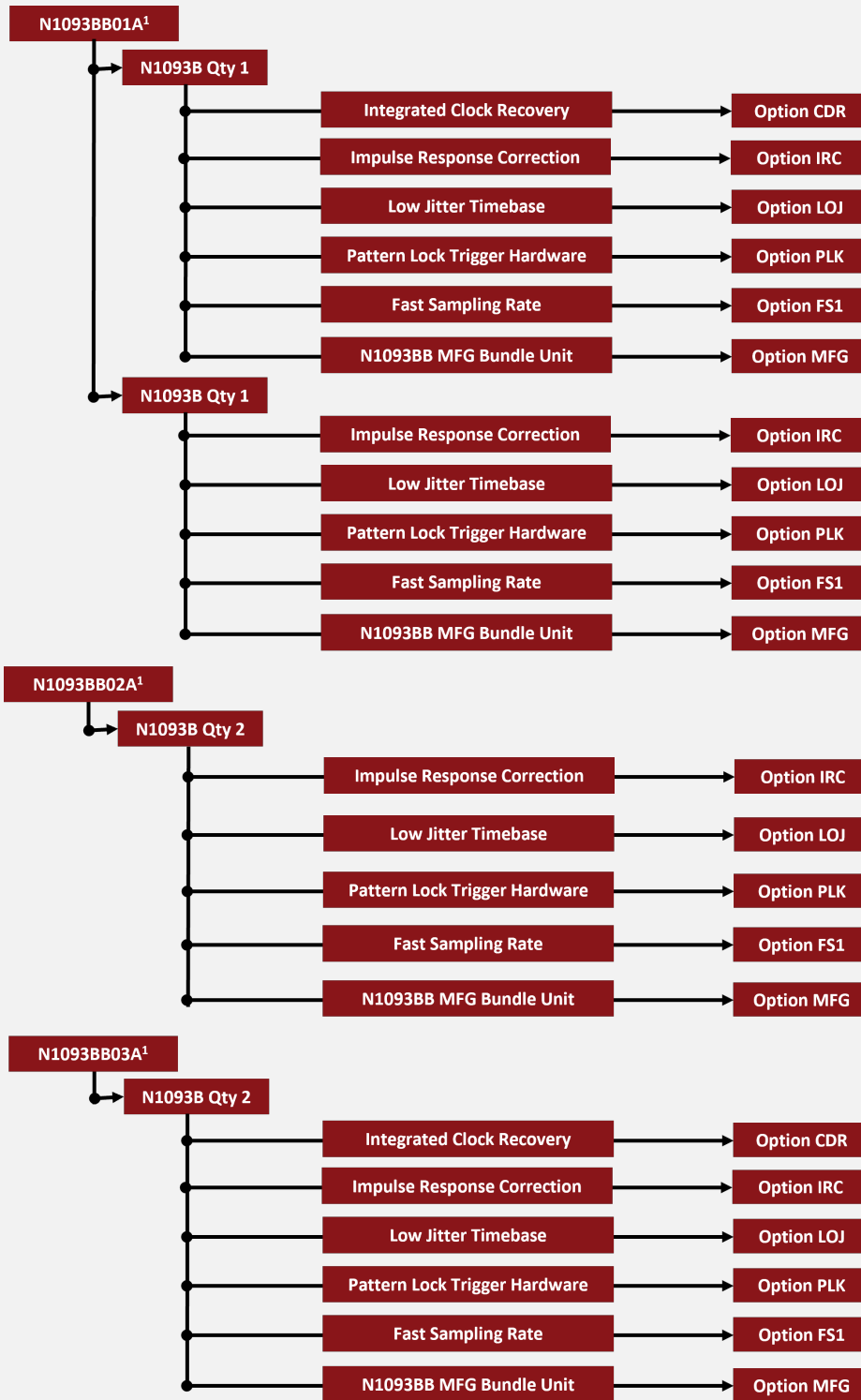

Figure 34. N1093BB0xA configuration chart

1. Minimum order quantity for N1093BB0xA bundles is two bundles.

## N1094A/B 2/4 Channel Electrical DCA-M Sampling Oscilloscope

A compact and efficient solution for electrical eye, waveform, and jitter analysis, delivering high precision and performance to meet your testing needs.

- 20/33 GHz and 20/33/40/50 GHz bandwidth settings support OIF and Ethernet standards
- Characteristic intrinsic jitter: 400 fs (standard), 135 fs (Option LOJ)
- Maximum sampling rate: 100 kSa/s (standard), 250 kSa/s (Option FS1)
- Controlled by N1010A FlexDCA application (free download) or DCA-X mainframe

Product/option	Description
N1094A	Dual electrical channel oscilloscope
N1094B	Quad electrical channel oscilloscope
N1094A/B-030	33 GHz maximum bandwidth
N1094A/B-050	50 GHz maximum bandwidth
N1094A/B-STB	Standard timebase
N1094A/B-LOJ	Low jitter timebase
N1094A/B-PLK	Pattern lock trigger hardware (requires Option LOJ)
N1094A/B-FS1	Fast sampling rate
N1094A/B-C0C	Certificate of calibration
N1094A/B-UK6	Commercial calibration certificate with test data
N1094A/B-1CM	Single instrument rack mount kit
N1092A/B-1CN	Dual instrument side by side rack mount kit
N1010100A	R&D package for FlexDCA (requires pattern lock capability)
N1010200A	Manufacturing package for FlexDCA (requires pattern lock capability)



Figure 35. N1094B quad electrical DCA-M with Option 050

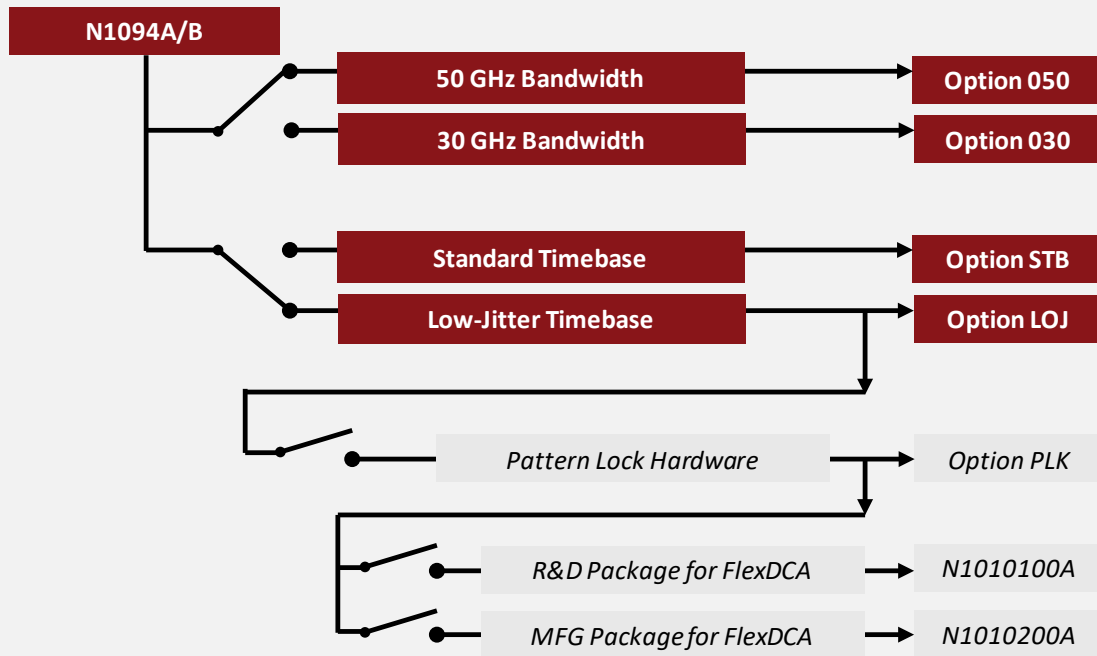

Figure 36. N1094A/B configuration chart

## N1096A/B 1/2 Channel Optical DCA-M Sampling Oscilloscope

The N1096 Single and Dual Channel DCA-M supports 224 Gbps or 112 GBd PAM4 measurement capability for multimode (MM) short-reach applications for next-generation AI infrastructure.

- 780 to 1100 nm, multimode
- Optical bandwidth 58 GHz with System Impulse Response Correction (SIRC) enabled
- High sensitivity optical channel with  $\leq 35 \mu\text{W}$  noise
- Accurate high data-rate analysis with  $<200$  fs jitter (option LOJ)
- Controlled by N1010A FlexDCA software (free download) or DCA-X mainframe

Product/option	Description
N1096A/B	Single/dual optical channel oscilloscope
N1096x-LOJ	Low jitter timebase
N1096x-PLK	Pattern lock trigger hardware
N1096x-FS1	Fast sampling rate
N1096x-IRC	Impulse response correction
N1096x-C0C	Certificate of calibration
N1096x-UK6	Commercial calibration certificate with test data
1CM124A	Single DCA-M Rack Mount Kit
1CN118A	Dual DCA-M side by side rack mount
N1010100A	R&D package for FlexDCA
N1010200A	Manufacturing package for FlexDCA



Figure 37. N1096B dual optical DCA-M

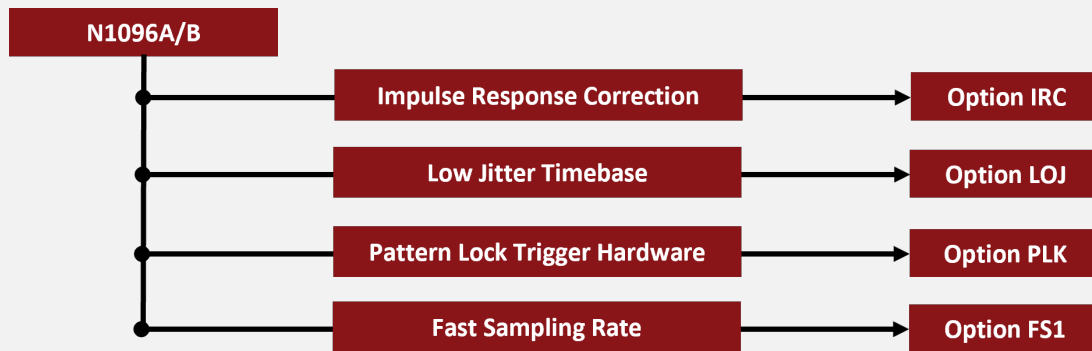

Figure 38. N1096A/B configuration chart

## N1010x00A Analysis Packages

Analysis Packages provide advanced features that deliver deeper insight into signal and DUT characteristics, significantly improve throughput, and convert raw data into powerful visualizations. The table below shows how the key feature sets map with the legacy N1010A-xxx licenses and the newer N1010100A R&D, N1010200A MFG, and N1010300A SI offerings.

Feature description	Legacy option	N1010100A (RND)	N1010200A (MFG)	N1010300A (SI)
Advanced amplitude analysis/RIN/Q-Factor	300	X		
Advanced eye analysis	401	X		
Automatic fixture removal in TDR mode	BFP			X
Enhanced impedance and S-Parameters	202		X	X
Enhanced jitter analysis	200	X		
Equalizers (CTLE, DFE, LFE)	201	X		
Access to licenses on remote DCA	DCA	X	X	X
Independent eye acquisition and analysis (FlexEye)	EFP	X	X	
PAM-N analysis (basic: includes TDECQ, EW/EH, Linearity: excludes 802.3cu measurements)	9FP	X	X	
Send data to analytics web service	-	X	X	X
TDEC Transmitter and Dispersion Eye Closure for NRZ	500	X	X	
TDECQ measurement, OOMA, OER, Ceq, noise margin	TFP	X	X	
Partial TDECQ, noise margin, and SER measurements	TFP/9FP	X		
Unrestricted data file import	-	X		
User defined measurements and operators	201	X		X
Waveform transformations (embedding/de-embedding)	SIM	X		
AWG waveform optimization	-	X		
Keysight arbitrary waveform generator control	-	X		
Chord operators (CNRZ-5-EE, ENRZ)	-	X		
Overshoot, undershoot and peak-to-peak amplitude (802.3cu)	-	X	X	
PAM4 mask test measurements (OpenEye MSA)	-	X	X	
FlexPLL Phase-Locked Loop (PLL) analysis	-			X
FlexRT – Basic (includes optical Tx measurements such as TDECQ, OOMA, OER, power)	-	X	X	
FlexRT – Advanced (basic and advance optical measurements, remote connection from PC to RT scope)	-	X		
ITU 50G PON TDEC measurement	-	X	X	
TDECQ for 802.3db	-	X	X	
Clock Pattern Distortion Compensation for TDECQ	-	X	X	
Jitter Spectrum Analysis	JSA	X		X
IEEE 802.3ck 53 GBd PAM4 electrical test (CTLE, DFE, VEC in jitter mode, Pulse Fit)	-	X		
Low SNR measurement feature	-	X	X	
SNDR (Signal-to-Noise-and-Distortion Ratio) measurement	-	X		
EECQ (Electrical Eye Closure Quaternary) and Partial EECQ	-	X	X	
CER TDECQ and CER Noise Margin	-	X	X	
Phase-Only Jitter (POJ) scalar measurements feature	-	X		
Intrinsic Noise Reduction (INR) feature	-	X	X	

# Appendix

## Application software

SW application model	SW application description <i>See the application software datasheet to confirm hardware requirements.</i>
N1095DJCA	224G Optical Transmitter Conformance Test Software for IEEE 802.3dj
N1091DJPA	224G Electrical Transmitter Test Software for IEEE 802.3dj
N109212CA	Electrical TX Test SW for OIF-CEI-112G
N1091CKCA	Electrical TX test SW for IEEE 802.3ck
N1095BSCA	Optical TX Test SW for IEEE 802.3bs/cd/cu
N109256CB	Electrical TX Test SW for OIF-CEI-4.0
N1091BSCB	Electrical TX Test SW for IEEE 802.3bs/cd
N1091BJCA	Electrical TX Test SW for IEEE 802.3bj (100G)
N1091BACA	Electrical TX Test SW for IEEE 802.3ba (40G/100G)
N1091BMCA	Electrical TX Test SW for IEEE 802.3bm
N1091APCA	Electrical TX Test SW for IEEE 802.3ap (10G/40G)
N1081PLCA	PLL Test SW for PCI Express
D9010UDAA	User Defined Application Software (for DCA-X and RT Scopes)
N1002000A	FlexOTO Optical Test Optimization SW for Basic Optimization
N1002014A	FlexOTO Optical Test Optimization SW for up to 17 ports
N1002048A	FlexOTO Optical Test Optimization SW for up to 48 ports
N1002128A	FlexOTO Optical Test Optimization SW for up to 128 ports

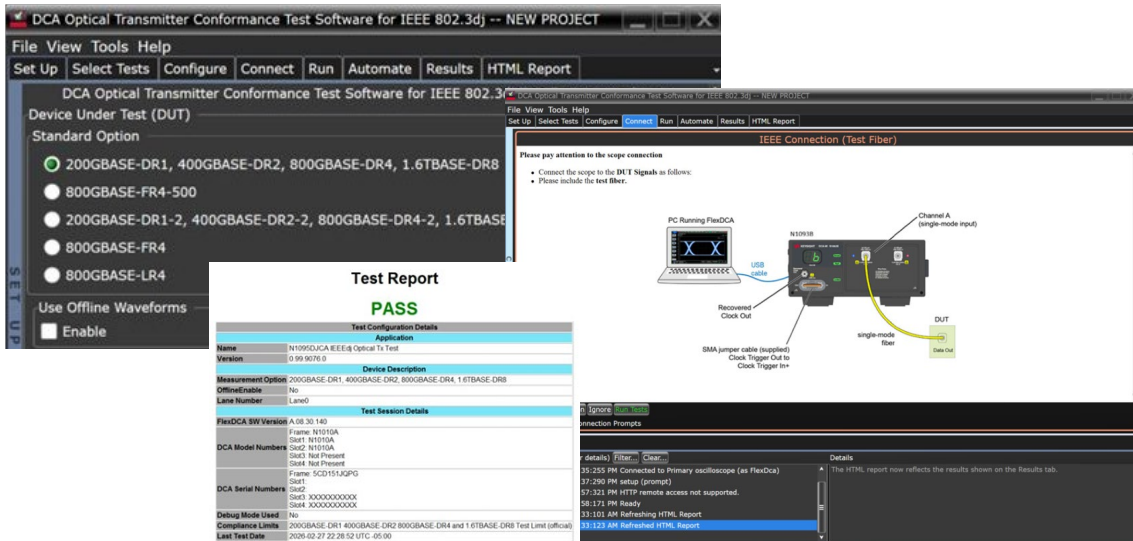

## Common DCA accessories

Keysight offers a collection of accessories for the N10xxx series of Digital Communication Analyzers (DCA-Xs, DCA-Ms). Popular accessories/spare parts include:

### Cables

N1027A-1C1	Coaxial RF cable, 1.85 mm, 67 GHz, 100 mm
N1027A-3C1	Coaxial RF cable, 2.92 mm, 2.37 ns delay, 0.55 m length
N1027A-3C2	Coaxial RF cable, 2.92 mm, 4.33 ns delay, 1.0 m
N1027A-3C3	Coaxial RF cable, SMA, for N1076A/B data out/data in

### Pick-offs, equalizers

N1027A-2P1	Microwave pick-off tee 1.0 mm connectors, matched pair
N1027A-2P8	Microwave pick-off tee 1.85 mm connectors, matched pair
N1027A-2P2	Microwave pick-off tee 2.4 mm connectors, matched pair
N1027A-2P3	Microwave pick-off tee 2.92 mm connectors, matched pair
N1027A-EF6	Equalizer, 2.92 mm (m) to 2.92 mm (f), 6 dB, up to 56 GBd
N1027A-EQ3	Equalizer, 2.92 mm (m) to 2.92 mm (f), 3dB
N1027A-EQ6	Equalizer, 2.92 mm (m) to 2.92 mm (f), 6dB
N1027A-EQ9	Equalizer, 2.92 mm (m) to 2.92 mm (f), 9dB

### Adapters, DC blocks

11920A/B/C	1.0 mm to 1.0 mm adapters (e.g., for N1046A)
11921E/F/G/H	1.0 mm to 1.85 mm adapters (e.g., for N1046A)
Y1900B/1B/3B	Ruggedized 1.0 mm to 1.0/1.85/2.92 mm adapters (e.g., for N1060A)
11904A/B/C/D	2.4 mm to 2.92 mm adapters (e.g., for N1092X, N1094X)
N9398C/F/G	DC blocks
11636B/C	DC coupled RF/microwave power dividers

For a comprehensive list of DCA accessories see literature number [5991-2340EN](#).

## DCA input connectors

Product	3.5 mm	2.92 mm	2.4 mm	1.85 mm	1.0 mm	Optical	Comment
N1000A		f/f CS					
N1030A/B					m fixed (#EC1)	FC/PC	#EC1 ships with 1.0 (f) to 1.85 (f) adapter(s)
N1032A/B						FC/PC	
N1040A		f/f CS (#033)		f/f CS (#060)			
N1045A/B-xxF				f fixed			
N1045A/B-xxM				m fixed			
N1046A					f fixed		Ships with 1.0 (m) to 1.85 (f) adapter(s)
N1055A-3xF		f fixed					
N1055A-3xM		m fixed					
N1055A-5xF				f fixed			
N1055A-5xM				m fixed			
N1060A Channel A/B					m fixed		Ships with 1.0 (f) to 1.85 (f) and 1.0 (f) to 2.92 (f) adapters
N1060A PTB, Clock Out		f fixed					
N1076B		f fixed					
N1077B/78A		f fixed				FC/PC	
N1090A	f SMA					FC/PC	
N1092A/B/D						FC/PC	
N1092C/E			f/f CS			FC/PC	
N1093A/B						FC/PC	
N1094A/B			f/f CS				#030 ships with 2.4 (f) to 2.92 (f) adapters
N1096A/B						FC/PC	

- **f/f CS:** Female/female connector saver (bulkhead is male, customer can remove connector saver)
- **f fixed:** Female fixed interface
- **m fixed:** Male fixed interface
- **f SMA:** Female SMA input (fixed)
- **FC/PC:** Cleanable FC/PC interface
- **1.0 mm inputs** ship with adapters to 1.85 mm (f) standard
- **DCA-M clock:** Clock inputs of the N109XX DCA-M series have 2.92 female connectors

## RF/Microwave connectors

### 3.5 mm connector

The 3.5 mm connector was primarily developed at Hewlett Packard—now Keysight Technologies, Inc. with early manufacturing at Amphenol. Its design strategy focused on highly-rugged physical interfaces that would mate with popular SMA dimensions, allowing thousands of repeatable connections. It is mode-free to 34 GHz.

### 2.92 mm connector

The 2.92 mm connector mates with SMA and 3.5 mm connectors and offers mode-free performance to 40 GHz.

### 2.4 mm connector

The 2.4 mm connector was developed by Hewlett Packard, Amphenol, and M/A-COM for use to 50 GHz. This design eliminates the fragility of the SMA and 2.92 mm connectors by increasing the outer wall thickness and strengthening the female fingers. It can mate with SMA, 3.5 mm and 2.92 mm, with the use of precision adapters. The 2.4 mm product is offered in three quality grades: general purpose, instrument, and metrology. General-purpose grade is intended for economy use on components, cables, and microstrip where limited connections and low repeatability is acceptable. Instrument-grade is best suited for measurement applications where repeatability and long life are primary considerations. Metrology-grade is best suited for calibration applications where the highest performance and repeatability are required.

### 1.85 mm connector

The 1.85 mm connector was developed in the mid-1980s by Hewlett Packard (now Keysight Technologies) for mode-free performance to 65 GHz. Hewlett Packard offered their design as public domain in 1988 to encourage standardization of connector types; a few devices are available from various manufacturers for research work. The 1.85 mm connector mates with the 2.4 mm connector and has the same ruggedness. In recent years, the 1.85 mm connector has been optimized to operate mode-free to 67 GHz.

### 1.0 mm connector

The 1.0 mm connector was designed for ultra-high frequency coaxial signals DC to at least 110 GHz. It utilizes an air dielectric interface for the highest accuracy and repeatability. The coupling diameter and thread size were chosen to maximize strength, increase durability and provide highly repeatable connections. The connector is designed so that the outer conductor engages before the center conductor.

## DCA Upgrades

Model Number	Upgrade Options	Return to factory
N1000A	N1000AU-LOJ, Upgrade of low jitter timebase N1000AU-PLK, Upgrade of pattern lock trigger N1000AU-PTB, Upgrade of internal precision timebase N1000AU-CNW, Upgrade CPU and WIN 11	Yes
	N1000AU-W11, Upgrade from WIN 10 to WIN 11, Customer Installable	No
N1030A	N1030AU-490, Upgrade of hardware filter for 49.77 Gbaud ITU-T G.hsp (PON) rate	Yes
N1030B	N1030BU-490, Upgrade of hardware filter for 49.77 Gbaud ITU-T G.hsp (PON) rate	Yes
N1032A	N1032AU-112, Upgrade of hardware filters for standards-based rates	Yes
	N1032AU-13U, Upgrade of single optical channel 90 GHz to 120 GHz	
N1032B	N1032BU-112, Upgrade of hardware filters for standards-based rates	Yes
	N1032BU-13U, Upgrade of 2 optical channel 90 GHz to 120 GHz	
N1046A	N1046AU-711, Upgrade of single electrical channel 75 GHz to 100 GHz	Yes
	N1046AU-718, Upgrade of single electrical channel 75 GHz to 85 GHz	
	N1046AU-721, Upgrade of 2 electrical channels 75 GHz to 100 GHz	
	N1046AU-728, Upgrade of 2 electrical channels 75 GHz to 85 GHz	
	N1046AU-741, Upgrade of 4 electrical channels 75 GHz to 100 GHz	
	N1046AU-748, Upgrade of 4 electrical channels 75 GHz to 85 GHz	
	N1046AU-811, Upgrade of single electrical channel 85 GHz to 100 GHz	
	N1046AU-821, Upgrade of 2 electrical channels 85 GHz to 100 GHz	
N1055A	N1055AU-34F, Upgrade of 2 CH to 4 CH Upgrade, 35 GHz BW, Female	Yes
	N1055AU-34M, Upgrade of 2 CH to 4 CH Upgrade, 35 GHz BW, Male	
	N1055AU-54F, Upgrade of 2 CH to 4 CH Upgrade, 50 GHz BW, Female	
	N1055AU-54M, Upgrade of 2 CH to 4 CH Upgrade, 50 GHz BW, Male	
	N1055AU-F52, Upgrade of 35 GHz to 50 GHz BW, 2 CH, Female	
	N1055AU-F54, Upgrade of 35 GHz to 50 GHz BW, 4 CH, Female	
	N1055AU-M52, Upgrade of 35 GHz to 50 GHz BW, 2 CH, Male	
	N1055AU-M54, Upgrade of 35 GHz to 50 GHz BW, 4 CH, Male	
N1055AU-FS1, Upgrade of fast sampling rate		
N1060A	N1060AU-085, Upgrade of 50 GHz to 85 GHz BW	Yes
	N1060AU-232, Upgrade of clock recovery input rates up to 32 GBd	
	N1060AU-264, Upgrade of clock recovery input rates up to 64 GBd	
	N1060AU-E33, Upgrade of adding 33, 40, 43 GHz hardware filters	
N1076B	N1076BU-232, Upgrade of clock recovery input rates up to 32 GBd	Yes
	N1076BU-264, Upgrade of clock recovery input rates up to 64 GBd	
N1077B	N1077BU-232, Upgrade of clock recovery input rates up to 32 GBd	Yes
	N1077BU-264, Upgrade of clock recovery input rates up to 64 GBd	
N1078A	N1078AU-232, Upgrade of clock recovery input rates up to 32 GBd	Yes
	N1078AU-264, Upgrade of clock recovery input rates up to 64 GBd	

Model Number	Upgrade Options	Return to factory
N1090A	N1090AU-140, Change reference receiver filtering to 1.244/1.25/1.229 Gb/s N1090AU-160, Change reference receiver filtering to 2.458/2.488/2.5 Gb/s N1090AU-200, Change reference receiver filtering to 8.5/9.95/10.3/10.5/10.66/10.71/11.1/11.3 Gb/s N1090AU-204, Change reference receiver filtering to 8.5/9.95/10.3/10.5 Gb/s N1090AU-EEC, Adding single electrical channel N1090AU-PLK, Upgrade of pattern lock trigger N1090AU-IRC, Upgrade of impulse response correction	Yes
N1092A N1092B N1092C N1092D N1092E	N1092xU-LOJ, Upgrade of low jitter timebase N1092xU-PLK, Upgrade of pattern lock trigger N1092xU-IRC, Upgrade of impulse response correction N1092xU-FS1, Upgrade of fast sampling rate N1092xU-168 <sup>1</sup> , 25.78 Gb/s TDEC Filter N1092xU-206 <sup>1</sup> , 20.6 Gb/s Reference Receiver N1092xU-200 <sup>2</sup> , Enable Enhanced Jitter Analysis N1092xU-201 <sup>2</sup> , Enable Advanced Waveform Analysis N1092xU-300 <sup>2</sup> , Enable Advanced Amplitude Analysis/Rin/Q-Factor N1092xU-401 <sup>2</sup> , Enable Advanced Eye Analysis N1092xU-500 <sup>2</sup> , Enable Productivity Package and TDEC Measurement N1092xU-9FP <sup>2</sup> , Enable PAM-N Analysis N1092xU-EFP <sup>2</sup> , Enable Flex Eye N1092xU-SIM <sup>2</sup> , Enable InfiniiSim-DCA Waveform Transformation N1092xU-TFP <sup>2</sup> , Enable IEEE TDECQ Analysis	Yes
	N1092AU/BU-CRX, Extended CDR rates: 125 MBd to 64 GBd, SW license upgrade	No
N1093A N1093B <sup>3</sup>	N1093AU/BU-CDR, Integrated Clock Recovery Upgrade, SW license upgrade N1093AU/BU-CRX, Extended Clock Recovery Range Upgrade, SW license upgrade N1093AU/BU-PTB, Integrated Precision Timebase Upgrade, SW license upgrade	No
N1094A N1094B	N1092xU-050, Upgrade of 33 GHz to 50 GHz BW N1092xU-LOJ, Upgrade of low jitter timebase N1092xU-PLK, Upgrade of pattern lock trigger N1092xU-FS1, Upgrade of fast sampling rate N1092xU-200 <sup>2</sup> , Enable Enhanced Jitter Analysis N1092xU-201 <sup>2</sup> , Enable Advanced Waveform Analysis N1092xU-300 <sup>2</sup> , Enable Advanced Amplitude Analysis/Rin/Q-Factor N1092xU-401 <sup>2</sup> , Enable Advanced Eye Analysis N1092xU-500 <sup>2</sup> , Enable Productivity Package and TDEC Measurement N1092xU-9FP <sup>2</sup> , Enable PAM-N Analysis N1092xU-EFP <sup>2</sup> , Enable Flex Eye N1092xU-SIM <sup>2</sup> , Enable InfiniiSim-DCA Waveform Transformation N1092xU-TFP <sup>2</sup> , Enable IEEE TDECQ Analysis	Yes

1. Only available in N1092x Option 30A.

2. Legacy Software Options have been replaced with N1010100A/200A/300A (R&D/MFG/SI) package licenses. Refer to N1010x00A Analysis Packages mapping table for details.

3. Upgrades are not available for N1093B MFG bundle units.

## Literature References

Description	Literature
DCA Wide-Bandwidth Oscilloscope Family - <i>Configuration Guide</i>	5992-3372EN
DCA Family - <i>Brochure</i>	5992-3301EN
Flexible Optical Test Optimization (FlexOTO) Software and Solutions – Flyer	3123-1111EN
Keysight DCA Family FlexDCA Sampling Oscilloscope Software - <i>Technical Overview</i>	5992-3319EN
N1000A DCA-X Mainframe and Modules - <i>Data Sheet</i>	5992-3271EN
N1092A/B/C/D/E DCA-M - <i>Data Sheet</i>	5992-3886EN
N1094A/B DCA-M - <i>Data Sheet</i>	5992-3700EN
N1090A DCA-M - <i>Data Sheet</i>	5992-3655EN
Keysight DCA Family Clock Data Recovery Solutions - <i>Data Sheet</i>	5992-1620EN
DCA Accessories – <i>Technical Overview</i>	5991-2340EN

## Web Resources

Generic: [www.keysight.com/find/<product number>](http://www.keysight.com/find/<product number>) for any product number mentioned here

- Keysight Digital Communication Analyzer (DCA) Solutions: [www.keysight.com/find/dca](http://www.keysight.com/find/dca)
- DCA-X Family: [www.keysight.com/find/dca-x](http://www.keysight.com/find/dca-x)
- DCA-M Family: [www.keysight.com/find/dca-m](http://www.keysight.com/find/dca-m)
- Clock Recovery Solutions: [www.keysight.com/find/cdr](http://www.keysight.com/find/cdr)
- FlexOTO Optical Test Optimization Solutions and N1002A: [www.keysight.com/find/flexoto](http://www.keysight.com/find/flexoto)
- FlexDCA (main page): [www.keysight.com/find/flexdca\\_pro](http://www.keysight.com/find/flexdca_pro)
- FlexDCA (download page): [www.keysight.com/find/flexdca\\_download](http://www.keysight.com/find/flexdca_download)

Learn more at: [www.keysight.com](http://www.keysight.com)

For more information on Keysight Technologies' products, applications, or services, please contact your local Keysight office. The complete list is available at: [www.keysight.com/find/contactus](http://www.keysight.com/find/contactus)

