

AC/DC Current Probe Model MR561



The AEMC® MR Series AC/DC Probes are professional AC/DC current probes designed to extend current measuring capabilities of DMMs, oscilloscopes and other instruments. They are built to the latest safety and performance standards, including the CE Mark. Two different hook-shaped jaws are offered, both permitting the user to “pry” or “hook” onto cables (will accept 2 x 500MCM) or even onto small bus bars.

The MR Series probes use Hall effect technology and measure AC and DC current. The electronics and batteries are self-contained in the handles. The output of the AC/DC probes is 1mV/A and 10mV/A. The Model MR561 measures to 1000AAC/1500AAC. The Model MR461 has two ranges and an auto-zero push button (patent pending) for quick DC zeroing.

There is no output filtering — True RMS with DC component measurements are possible. Phase shift is excellent, making the MR Series of current probes well suited for power and power quality applications.

The Model MR561 is designed for oscilloscopes, waveform displaying instruments and other frequency sensitive displaying instruments with BNC inputs.

Features

- Measurement range of 1000Aac/1500Aac
- Distinct jaw shapes to be used for hooking or prying around the conductor
- Auto-zero push button
- Auto off after ten minutes
- Conforms to EN 61010, 600V, CAT III safety standard
- Low phase shift for power measurements
- mV output signals
- Designed for DMMs, recorders, oscilloscopes, power and harmonic meters
- Double Insulation
- CE Mark

Applications

- DC motors
- Batteries
- Automobile engine testing
- Power measuring quality analysis
- Power load monitoring

Specifications

MODELS	MR561
ELECTRICAL	
Nominal Range	100A _{AC} /150A _{DC} & 1000A _{AC} /1500A _{DC}
Measurement Range	0.2 to 1500A
Output Signal	150A: 10mV/A 1500A: 1mV/A
Accuracy (150A _{DC} Range)	1.5% of Reading ± 0.5A
0.5 to 20A	
20 to 100A	1.5% of Reading
100 to 150A _{DC} only	2.5% of Reading
Phase Shift (150A Range)	
10 to 20A	≤3.5°
20 to 100A	≤3°
Accuracy (1500A _{DC} Range)	1.5% of Reading ± 1A
0.5 to 100A	
100 to 800A	2.5% of Reading
800 to 1000A	4% of Reading
1000 to 1400A _{DC} only	4% of Reading
Phase Shift (1500A Range)	
10 to 200A	≤3°
200 to 1000A	≤2.5°
Overload	1000A _{AC} and 1500A _{DC} continuous up to 1kHz
Frequency Range	DC to 10kHz @ -3dB
Load Impedance	>100kΩ/100pF max
Working/Common Mode Voltage	600Vrms
Battery	9V Alkaline (Approx. 50 hours life)
Output Termination	6 ft BNC
MECHANICAL	
Operating Temperature	14° to 131°F (-10° to 55°C)
Storage Temperature	-40° to 176°F (-40° to 70°C)
Operating Relative Humidity	10 to 35°C 90% ± 5% RH (without condensation), 40 to 55°C 70% ± 5% RH (without condensation)
Zero Adjustment	Auto-zero
Jaw Opening	1.2" (31mm)
Maximum Conductor Size	One 1.5" (39mm) or two 0.95" (24mm) or two bus bars 1.96 x 0.19" (50 x 5mm) or one bus bar 1.96 x 0.49" (50 x 12.5mm)
Dimensions	8.8 x 3.82 x 1.73" (224 x 97 x 44mm)
Weight	15 oz (440g)
Polycarbonate Material	Handles: Polycarbonate +ABS, Gray, UL94 V0. Jaws: Polycarbonate, Red, UL94 V0
SAFETY	
Electrical	EN 61010-2-32
Double Insulation <input type="checkbox"/>	Yes
CE Mark	Yes

Note: Reference conditions: 18°C to 28°C, 20 to 75% RH, external magnetic field <40A/m, no DC component, no external current carrying conductor, test sample centered, 1MΩ ≤ 100pF load, zero adjustment (DC only) DC to 65Hz, battery voltage 9V ± 0.1V

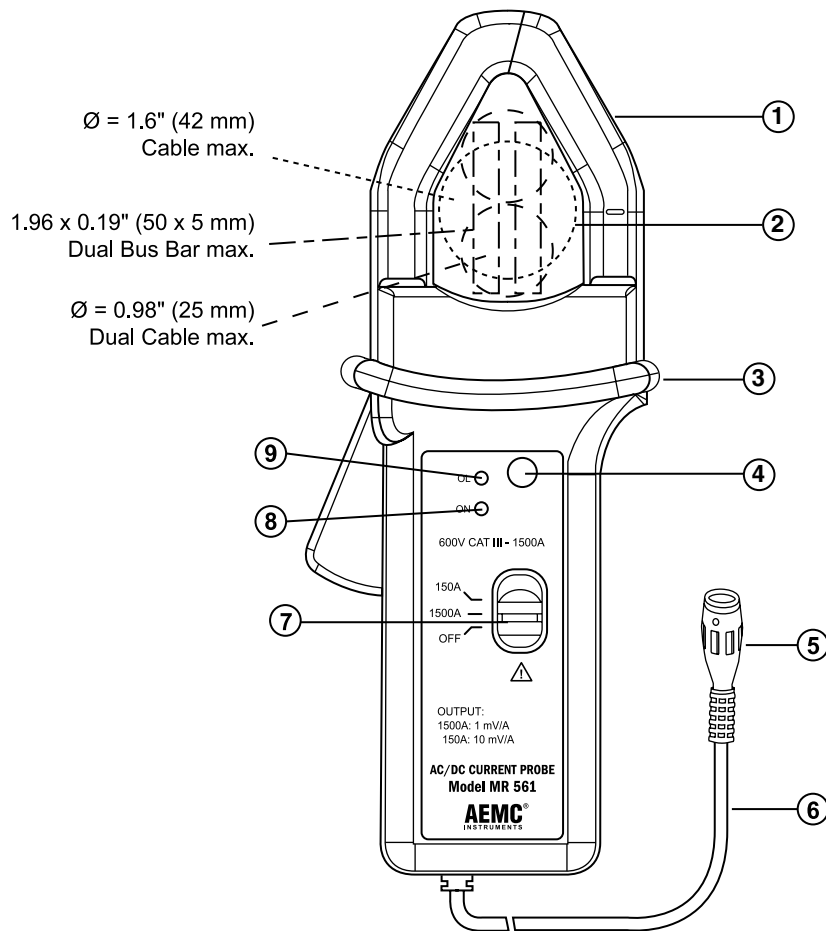

- | | |
|--|---|
| <ul style="list-style-type: none"> 1. Jaws 2. Conductor 3. Protective non-slip guard 4. Automatic zero DC button 5. BNC connector 6. Lead, 5 ft (1.5m) | <ul style="list-style-type: none"> 7. Range selection switch: <ul style="list-style-type: none"> • On/Off • 1500A (1mV/A) • 150A (10mV/A) 8. Green light (on when battery voltage $\geq 6.5V$) 9. Red light (overrange and incorrect zero adjustment) |
|--|---|



Lead with BNC:
Insulated 6.5 ft (2m) coaxial cable with insulated BNC connector rated 600Vrms

ORDERING INFORMATION	CATALOG NO.
AC Current Probe Model MR561 (BNC – 10mV/A – 150A max & 1mV/A – 1500A max)	Cat. #1200.73
Includes a user manual	
Accessories (Optional)	
Banana/BNC connector XF-SS (4mm plug adaptor)	Cat. #2111.32

Contact Us

United States and Canada:

Chauvin Arnoux[®], Inc.
d.b.a. AEMC[®] Instruments
200 Foxborough Blvd.
Foxborough, MA 02035 USA
(508) 698-2115 • Fax (508) 698-2118
www.aemc.com

Customer Support – for placing an order, obtaining price and delivery:
customerservice@aemc.com

Sales Department – for general sales information:
sales@aemc.com

Repair and Calibration Service – for information on repair and calibration, obtaining a user manual:
repair@aemc.com

Technical and Product Application Support – for technical and application support:
techinfo@aemc.com

Webmaster – for information regarding www.aemc.com:
webmaster@aemc.com

South America, Central America, Mexico, Caribbean, Australia and New Zealand:

Chauvin Arnoux[®], Inc.
d.b.a. AEMC[®] Instruments
15 Faraday Drive
Dover, NH 03820 USA
(978) 526-7667 • Fax (978) 526-7605
export@aemc.com
www.aemc.com

All other countries:

Chauvin Arnoux SCA
190, rue Championnet
75876 Paris Cedex 18, France
33 1 44 85 45 28 • Fax 33 1 46 27 73 89
info@chauvin-arnoux.com
www.chauvin-arnoux.com