

Keysight Technologies

Signal Studio for TD-SCDMA/HSPA N7612B

Technical Overview

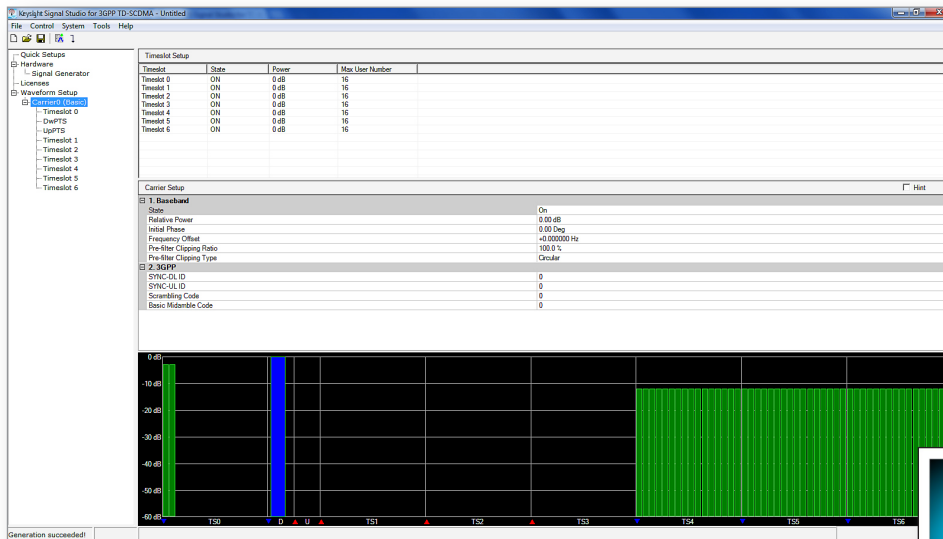

- Create Keysight validated and performance optimized reference signals compliant to the 3GPP 1.28 Mcps TDD and TD-SCDMA/HSPA
- All 3GPP physical and transport channels for TD-SCDMA/HSPA and HARQ, CQI and ACK/NACK functionality in HSPA mode
- Use predefined reference measurement channels (RMC) and fixed reference channels (FRC) to perform UE and BTS receiver conformance testing
- Licensing that fits your specific use case, timeframe and budget
- Easy-to-use, application-specific graphical interface for configuring signals
- Accelerate the signal creation process with a user interface based on parameterized and graphical signal configuration and tree-style navigation

Simplify TD-SCDMA/HSPA Signal Creation

Keysight Signal Studio software is a flexible suite of signal-creation tools that will reduce the time you spend on signal simulation. For TD-SCDMA/HSPA, Signal Studio's performance-optimized reference signals—validated by Keysight—enhance the characterization and verification of your devices. Through its application-specific user-interface you'll create standards-based and custom test signals for component, transmitter, and receiver test.

Component and transmitter test

Signal Studio's basic capabilities use waveform playback mode to create and customize waveform files needed to test components and transmitters. Its userfriendly interface lets you configure signal parameters, calculate the resulting waveforms and download files for playback. The applications for these partiallycoded, statistically correct signals include

- Parametric test of components, such as amplifiers and filters
- Performance characterization and verification of RF sub-systems

Receiver test

Signal Studio's advanced capabilities enable you to create fully channel-coded signals for receiver bit-error-rate (BER), or block-error-rate (BLER) analysis. Applications include

- Performance verification and functional test of receivers, during RF/baseband integration and system verification
- Coding verification of baseband subsystems, including FPGAs, ASICs, and DSPs

Apply your signals in real-world testing

Once you have setup your signals in Signal Studio, you can download them to a variety of Keysight instruments. Signal Studio software complements these platforms by providing a cost-effective way to tailor them to your test needs in design, development and production test.

- Vector signal generators
 - MXG X-Series
 - EXG X-Series
 - PSG
 - ESG
 - PXIe M9381A
- EXT wireless communication test set
- PXB baseband generator and channel emulator
- M9252A DigRF host adaptor
- SystemVue simulation software

Typical Measurements

Test components with basic capabilities

- IMD / NPR
- ACLR
- CCDF
- EVM
- Modulation accuracy
- Code domain power
- Channel power
- Occupied bandwidth

Verify receivers with advanced capabilities

- Sensitivity
- Maximum input level
- Selectivity
- Blocking
- Intermodulation
- Power control

Component and Transmitter Test



Figure 1. Typical component test configuration using Signal Studio's basic capabilities with a Keysight X-Series signal generator and an X-Series signal analyzer

Signal Studio's basic capabilities enable you to create and customize TD-SCDMA/HSPA signals to characterize the power and modulation performance of your components and transmitters on BTS and UE. Easy manipulation of a variety of signal parameters, including switching point, code domain power, and modulation type, simplifies signal creation.

- Create spectrally-correct signals for ACLR, channel power, spectral mask, and spurious testing
- Set parameters such as channel power and data channel modulation type (QPSK, 16QAM, 64QAM) for modulation verification and analysis, such as EVM tests
- Configure multi-carrier waveforms, each with modulation type, frequency offsets, timing offsets, power, baseband filter, and cell ID
- View CCDF, spectrum and time domain graphs to investigate the effects of power ramps, modulation formats, power changes, clipping, and other effects on device performance
- Simultaneously turn off all uplink and downlink timeslots to meet the requirements of power amplifier tests
- Generate slot-length based waveforms to help make fast PA tests with a waveform sequence.
- Use pre-defined Fixed Reference Channel(FRC) for UE component and transmitter tests

Receiver Test

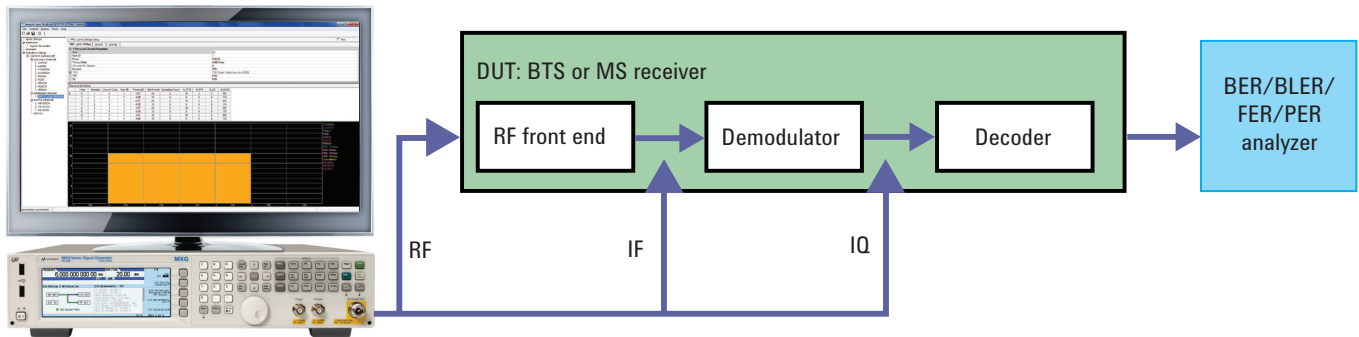

Figure 2. Generate fully channel-coded signals to evaluate the BER, BLER, PER, or FER of your receiver with Keysight X-Series signal generators and Signal Studio's advanced capabilities

Signal Studio's advanced capabilities address applications in TD-SCDMA/HSPA receiver test, including the verification of baseband designs and the integration of the baseband and RF modules. Using waveform playback mode enables transport-channel coding to validate BTS and UE receiver characteristics and performance.

BTS receiver testing

- Choose from a variety of pre-defined reference measurement channel (RMC) and FRC configurations for BTS receiver conformance testing
- Turn on the DPCH0 state to simulate multiple UE co-existence
- Customize rate matching attributes in the RMC configurations
- Configure uplink signals and HARQ feedback in HSDPA mode
- Set TFCI value based on BTS receiver configurations
- Advanced functional testing with HSUPA channels including E-PUCH, E-AGCH and E-HICH with transport layer coding
- Pre-defined uplink multi-code per standard requirement

UE receiver testing

- Choose a pre-defined reference measurement channel (RMC) configuration for early baseband verification
- Create HS-DSCH, HS-SCCH and HS-PICH in HSDPA mode
- Customize rate matching attributes in the RMC configurations
- Set TFCI values based on BTS receiver configurations
- Select downlink transmission CRC size, channel coding type and TTI value

TD-SCDMA BTS testing

The 3GPP TS25.142 specification defines how to test TD-SCDMA base station transmitters and receivers.

To address the challenges of testing TD-SCDMA components and receivers, Signal Studio for TD-SCDMA/HSPA enables you to generate multiple carriers and standard compliant reference measurement channels. The user interface allows you to adjust the carrier spacing, power offset, number of carriers, channel coding type, CRC size, and TFCI value to meet your test needs.

Features Summary

TD-SCDMA/HSPA	Component & transmitter testing	Receiver testing
Signal Studio	Basic waveform playback mode	Advanced waveform playback mode
TD-SCDMA	●	●
TD-HSDPA	●	●
Calibrated AWGN	●	●
Code domain and CCDF graphs	●	●
Multi-carrier timing and clipping	●	●
Short length waveform	●	●
Downlink		
Up to 12 carriers	●	●
Preconfigured RMC signals		●
PDSCH selectable modulations: QPSK, 8PSK, 16QAM, 64QAM	●	●
DL-SCH selectable CRC size, TTI, channel coding type, TFCI		●
S1/S2 phase pattern selection	●	●
HS-DSCH, HS-DCCH, and HS-SICH generation		●
Uplink		
Up to 12 carriers	●	●
Preconfigured RMC/FRC signals with transport channel coding		●
PRACH signal generation		●
Selectable UL-SCH coding rate, CRC size, data payload		●
HSUPA channels (E-PUCH, E-AGCH, and E-HICH)		●

Supported Standards

3GPP technical specification	Version
TS25.142	V11.4.0
TS25.221	V11.0.0
TS25.222	V11.0.0
TS25.321	V11.5.0
TS34.122	V11.6.0

Base station conformance tests (3GPP TS25.142)

TD-SCDMA/HSPA Signal Studio	Component & transmitter testing	Receiver testing
	Basic waveform playback mode	Advanced waveform playback mode
Maximum output power	●	
Frequency stability	●	
Output power dynamics	●	
Transmit ON/OFF power	●	
Output RF spectrum emissions	●	
Transmit intermodulation	●	
Transmit modulation	●	
Reference sensitivity level Dynamic range		●
Adjacent Channel Selectivity (ACS)		●
Blocking characteristics		●
Intermodulation characteristics		●
Spurious emissions		●

Performance Characteristics

Definitions

Specification (spec):

Represents warranted performance of a calibrated instrument that has been stored for a minimum of 2 hours within the operating temperature range of 0 to 55 °C, unless otherwise stated, and after a 45 minute warm-up period. The specifications include measurement uncertainty. Data represented in this document are specifications unless otherwise noted.

Typical (typ):

Represents characteristic performance, which 80% of the instruments manufactured will meet. This data is not warranted, does not include measurement uncertainty, and is valid only at room temperature (approximately 25 °C).

Measured (meas):

An attribute measured during the design phase for purposes of communicating expected performance, such as amplitude drift vs. time. This data is not warranted and is measured at room temperature (approximately 25 °C).

The following performance characteristics apply to the instruments indicated in the respective tables. For performance characteristics of other instruments, refer to the respective product data sheet.

ACLR performance

		N5172B and N5182B MXG				M9381A VSG	
		Standard		Option UNV		Standard	
Configuration	Offset	Specification (dBc)	Typical (dBc)	Specification (dBc)	Typical (dBc)	Measured (dBc)	Typical (dBc)
1 carrier	Adjacent (1.6 MHz)	-74.7	-75.6	-74.7	-75.2	-67.7	-67.2
	Alternate (3.2 MHz)	-76.2	-78.7	-76.2	-79.4	-75.0	-75.1
3 carrier	Adjacent (1.6 MHz)	-68	-71.5	-69.3	-71.6	-70.3	-69.0
	Alternate (3.2 MHz)	-69.7	-73.2	-71.3	-75	-74.5	-73.3
6 carrier	Adjacent (1.6 MHz)	-66.5	-69.7	-67.8	-71.1	-71.3	-70.2
	Alternate (3.2 MHz)	-66.4	-70.1	-68.6	-72.8	-74.4	-73.3

EVM performance

Configuration	N5172B and N5182B with Option UNV	M9381A
	Measured EVM	Typical EVM
1 carrier	< 0.37%	0.37% rms

Ordering Information

Software licensing and configuration

Signal Studio offers flexible licensing options, including:

- **Fixed license:** Allows you to create unlimited I/Q waveforms with a specific Signal Studio product and use them with a single, specific platform.
- **Transportable/floating license:** Allows you to create unlimited I/Q waveforms with a specific Signal Studio product and use them with a single platform (or PC in some cases) at a time. You may transfer the license from one product to another.
- **Waveform license:** Allows you to generate up to 545 user-configured I/Q waveforms with any Signal Studio product and use them with a single, specific platform.

The table below lists fixed, perpetual licenses only; additional license types may be available. For detailed licensing information and configuration assistance, please refer to the Licensing Options web page at www.keysight.com/find/SignalStudio_licensing

N7612B Signal Studio for 3GPP TD-SCDMA/HSPA

Model-Option	Description
Connectivity	
N7612B-1FP	Connect to E4438C ESG signal generator
N7612B-2FP	Connect to E8267D PSG signal generator
N7612B-3FP	Connect to N5182B/72B MXG/EXG signal generator
N7612B-6FP	Connect to N5106A PXB baseband generator and channel emulator
N7612B-7FP	Connect to Keysight simulation software
N7612B-8FP	Connect to E6607 EXT wireless communications test set
N7612B-9FP	Connect to M9381A or M9252A
Capability	
N7612B-EFP	Basic TD-SCDMA/HSPA
N7612B-QFP	Advanced TD-SCDMA/HSPA

Try Before You Buy!

Free 30-day trials of Signal Studio software provide unrestricted use of the features and functions, including signal generation, with your compatible platform. Redeem a trial license online at

www.keysight.com/find/SignalStudio_trial

Hardware configurations

To learn more about compatible hardware and required configurations, please visit: www.keysight.com/find/SignalStudio_platforms

PC requirements

A PC is required to run Signal Studio. www.keysight.com/find/SignalStudio_pc

Signal Studio Software Updates

To update previously purchased N7612B software to include the latest feature updates, you can purchase the N7612B-MEU minor enhancement update fixed perpetual license.

For more information, visit

www.keysight.com/find/N7612B-MEU

Additional Information

Websites

www.keysight.com/find/SignalStudio

Access the comprehensive online documentation, which includes the complete software HELP

www.keysight.com/find/N7612B

www.keysight.com/find/SignalStudio

Keysight's TD-SCDMA and HSPA design and test solutions

www.keysight.com/find/td-scdma

www.keysight.com/find/HSPA

Literature

Signal Studio Software, Brochure, literature number 5989-6448EN

myKeysight

myKeysight

www.keysight.com/find/mykeysight

A personalized view into the information most relevant to you.



www.lxistandard.org

LAN eXtensions for Instruments puts the power of Ethernet and the Web inside your test systems. Keysight is a founding member of the LXI consortium.



Three-Year Warranty

www.keysight.com/find/ThreeYearWarranty

Keysight's commitment to superior product quality and lower total cost of ownership. The only test and measurement company with three-year warranty standard on all instruments, worldwide.



Keysight Assurance Plans

www.keysight.com/find/AssurancePlans

Up to five years of protection and no budgetary surprises to ensure your instruments are operating to specification so you can rely on accurate measurements.



www.keysight.com/quality

Keysight Technologies, Inc.
DEKRA Certified ISO 9001:2008
Quality Management System

Keysight Channel Partners

www.keysight.com/find/channelpartners

Get the best of both worlds: Keysight's measurement expertise and product breadth, combined with channel partner convenience.

www.keysight.com/find/N7612B

For more information on Keysight Technologies' products, applications or services, please contact your local Keysight office. The complete list is available at: www.keysight.com/find/contactus

Americas

Canada	(877) 894 4414
Brazil	55 11 3351 7010
Mexico	001 800 254 2440
United States	(800) 829 4444

Asia Pacific

Australia	1 800 629 485
China	800 810 0189
Hong Kong	800 938 693
India	1 800 112 929
Japan	0120 (421) 345
Korea	080 769 0800
Malaysia	1 800 888 848
Singapore	1 800 375 8100
Taiwan	0800 047 866
Other AP Countries	(65) 6375 8100

Europe & Middle East

Austria	0800 001122
Belgium	0800 58580
Finland	0800 523252
France	0805 980333
Germany	0800 6270999
Ireland	1800 832700
Israel	1 809 343051
Italy	800 599100
Luxembourg	+32 800 58580
Netherlands	0800 0233200
Russia	8800 5009286
Spain	0800 000154
Sweden	0200 882255
Switzerland	0800 805353
	Opt. 1 (DE)
	Opt. 2 (FR)
	Opt. 3 (IT)
United Kingdom	0800 0260637

For other unlisted countries:
www.keysight.com/find/contactus
(BP-07-10-14)