PXI-2796

Specifications

2026-03-25



Contents

PXI-2796 Specifications 3

PXI-2796 Specifications

PXI-2796 Specifications

These specifications apply to the PXI-2796.

All specifications are subject to change without notice.



Notice The protection provided by the PXI-2796 can be impaired if it is used in a manner not described in this document.

About These Specifications

Specifications characterize the warranted performance of the instrument under the stated operating conditions. Data in this document are *Specifications* unless otherwise noted.

Typical Specifications are specifications met by the majority of the instrument under the stated operating conditions and are tested at 23 °C ambient temperature. Typical specifications are not warranted.

All voltages are specified in DC, AC_{pk}, or a combination unless otherwise specified.



Caution The protection provided by the PXI-2796 can be impaired if it is used in a manner not described in this document.

PXI-2796 Pinout

Use the pinout to connect to terminals on the PXI-2796.

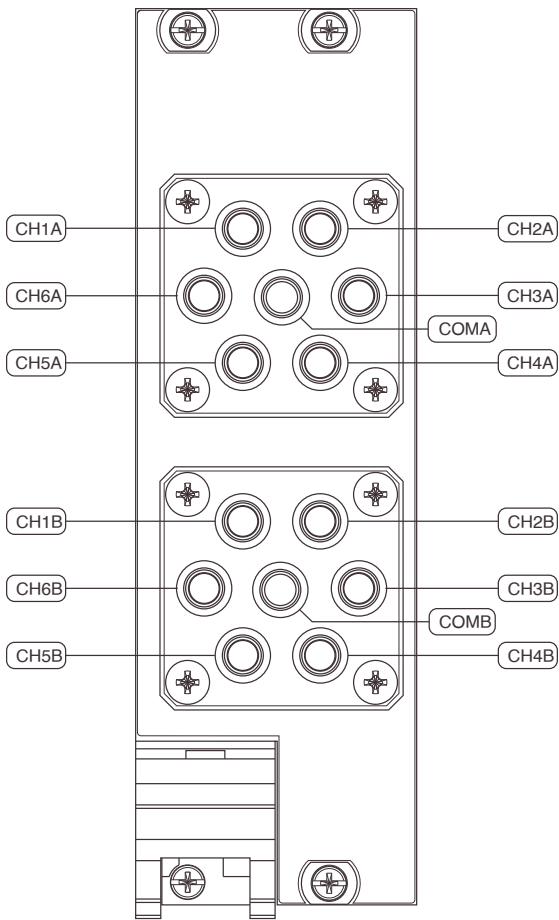

Table 1. Signal Descriptions

Signal	Description
CHxA	Bank A signal connection
CHxB	Bank B signal connection
COMx	Routing destination for channels on the corresponding bank

Related information:

- [PXI-2796 Hardware Diagram](#)
- [NI Switches Cable and Accessory Compatibility](#)

Input Characteristics

Maximum voltage (cold-switching only)	30 V _{rms}
---------------------------------------	---------------------



Caution Do not switch active RF signals. As a relay actuates, the channel is momentarily unterminated. Some RF sources can be damaged by reflections if their outputs are not properly terminated. Refer to your RF source documentation for more information.

Maximum carry current (per channel)	0.6 A _{rms}
Maximum RF carry power (50 Ω load)	18 W



Note The switching power is limited by the maximum switching current and the maximum voltage. Channel to common switching power must not exceed 18 W.



Note National Instruments recommends against switching RF signals below -35 dBm with this device.

RF Performance Characteristics

Characteristic impedance (Z_0)	50 Ω nominal
Insertion loss	
≤3 GHz	<0.2 dB

≤ 8 GHz	<0.3 dB
≤ 12.4 GHz	<0.4 dB
≤ 18 GHz	<0.5 dB
≤ 26.5 GHz	<0.7 dB
≤ 40 GHz	<1.1 dB
Voltage standing wave ratio (VSWR)	
≤ 3 GHz	<1.2
≤ 8 GHz	<1.3
≤ 12.4 GHz	<1.4
≤ 18 GHz	<1.5
≤ 26.5 GHz	<1.7
≤ 40 GHz	<2.2
Open channel isolation	
≤ 3 GHz	>80 dB

≤ 8 GHz	>70 dB
≤ 12.4 GHz	>60 dB
≤ 18 GHz	>60 dB
≤ 26.5 GHz	>55 dB
≤ 40 GHz	>45 dB
RF carry power	
≤ 18 GHz	18 W
≤ 26.5 GHz	15 W
≤ 40 GHz	5 W

Refer to the following figure for the typical insertion loss of the PXI-2796.

Figure 1. Typical Insertion Loss

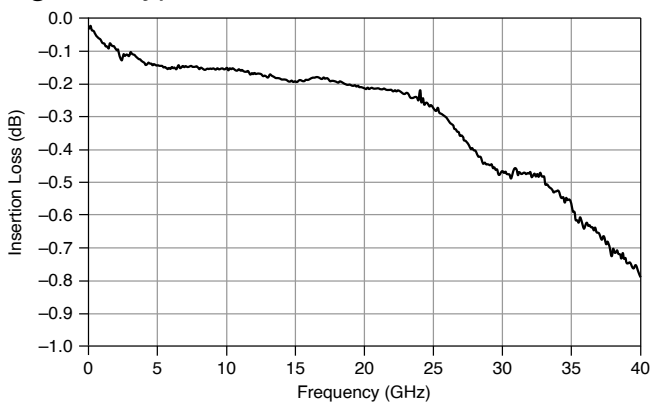

Refer to the following figure for the typical isolation of the PXI-2796.

Figure 2. Typical Isolation

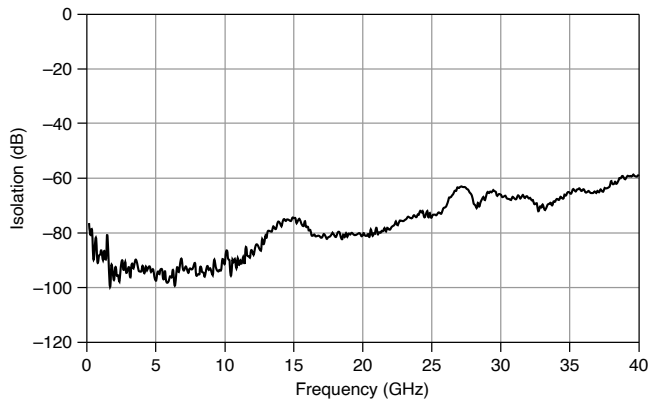

Refer to the following figure for the typical VSWR of the PXI-2796.

Figure 3. Typical VSWR

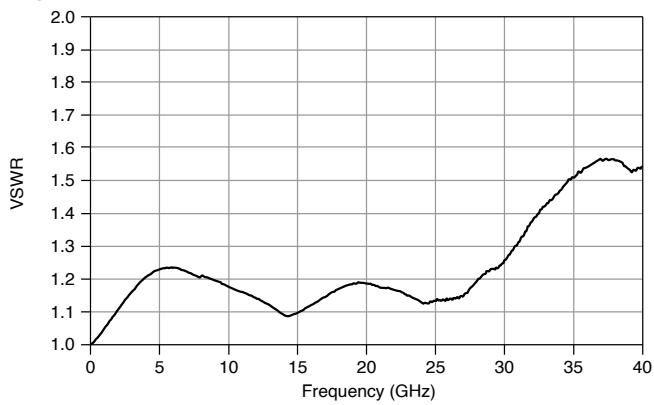

Dynamic Characteristics

Relay operate/release time	15 ms
Recommended cycle speed	5 channels/s
Expected mechanical relay life	2×10^6 cycles

Insertion loss repeatability	<0.03 dB (typical)
------------------------------	--------------------

Trigger Characteristics

Input trigger	
Sources	PXI trigger lines <0...7>
Minimum pulse width ¹	150 ns
Output trigger	
Destinations	PXI trigger lines <0...7>
Default pulse width	2 μ s, typical

Physical Characteristics

Relay manufacturer/ PN	Radiall/R592 series
Relay type	Electromechanical, non-latching
Contact material	Beryllium copper, gold-plated
I/O connector	14 SMA 2.9 jacks

1. The PXI-2796 recognizes trigger pulse widths less than 150 ns if digital filtering is disabled. Refer to the *NI Switches Help* for information about disabling digital filtering.

SMA torque	0.8 N · m to 1.1 N · m (7 in. · lbs to 10 in. · lbs)
PXI power requirement	2.5 W at 3.3 V 1 W at 5 V 6 W at 12 V
Dimensions (L × W × H)	3U, two slots, PXI/cPCI module 21.6 cm × 4.1 cm × 13.0 cm (8.5 in. × 1.6 in. × 5.1 in.)
Weight	378 g (13.25 oz)

Environment

Operating temperature	0 °C to 55 °C
Storage temperature	-20 °C to 70 °C
Relative humidity	5% to 85%, noncondensing
Pollution Degree	2
Maximum altitude	2,000 m

Indoor use only.

Shock and Vibration

Operational Shock	30 g peak, half-sine, 11 ms pulse (Tested in accordance with IEC 60068-2-27. Test profile developed in accordance with MIL-PRF-28800F.)
Random Vibration	
Operating	5 Hz to 500 Hz, 0.3 grms
Nonoperating	5 Hz to 500 Hz, 2.4 grms (Tested in accordance with IEC 60068-2-64. Nonoperating test profile exceeds the requirements of MIL-PRF-28800F, Class 3.)

Compliance and Certifications

Safety Compliance Standards

This product is designed to meet the requirements of the following electrical equipment safety standards for measurement, control, and laboratory use:

- IEC 61010-1, EN 61010-1
- UL 61010-1, CSA C22.2 No. 61010-1



Note For safety certifications, refer to the product label or the [Product Certifications and Declarations](#) section.

Electromagnetic Compatibility

This product meets the requirements of the following EMC standards for electrical equipment for measurement, control, and laboratory use:

- EN 61326-1 (IEC 61326-1): Class A emissions; Basic immunity
- EN 55011 (CISPR 11): Group 1, Class A emissions
- EN 55022 (CISPR 22): Class A emissions
- EN 55024 (CISPR 24): Immunity

- AS/NZS CISPR 11: Group 1, Class A emissions
- AS/NZS CISPR 22: Class A emissions
- FCC 47 CFR Part 15B: Class A emissions
- ICES-001: Class A emissions



Note In the United States (per FCC 47 CFR), Class A equipment is intended for use in commercial, light-industrial, and heavy-industrial locations. In Europe, Canada, Australia, and New Zealand (per CISPR 11), Class A equipment is intended for use only in heavy-industrial locations.



Note Group 1 equipment (per CISPR 11) is any industrial, scientific, or medical equipment that does not intentionally generate radio frequency energy for the treatment of material or inspection/analysis purposes.



Note For EMC declarations, certifications, and additional information, refer to the [Product Certifications and Declarations](#) section.

Product Certifications and Declarations

Refer to the product Declaration of Conformity (DoC) for additional regulatory compliance information. To obtain product certifications and the DoC for NI products, visit ni.com/product-certifications, search by model number, and click the appropriate link.

Environmental Management

NI is committed to designing and manufacturing products in an environmentally responsible manner. NI recognizes that eliminating certain hazardous substances from our products is beneficial to the environment and to NI customers.

For additional environmental information, refer to the *Engineering a Healthy Planet* web page at ni.com/environment. This page contains the environmental regulations and directives with which NI complies, as well as other environmental information not included in this document.

EU and UK Customers

-  **Waste Electrical and Electronic Equipment (WEEE)**—At the end of the product life cycle, all NI products must be disposed of according to local laws and regulations. For more information about how to recycle NI products in your region, visit ni.com/environment/weee.

电子信息产品污染控制管理办法（中国RoHS）

-  **中国RoHS**—NI符合中国电子信息产品中限制使用某些有害物质指令 (RoHS)。关于NI中国RoHS合规性信息，请登录 ni.com/environment/rohs_china。(For information about China RoHS compliance, go to ni.com/environment/rohs_china.)