

Keysight 346A/B/C Noise Source (Including Options 001, 002, and 004)

Instruments with serial prefixes 4124A and above are supplied with the noise source ENR data preloaded on diskette - see Chapters 3 & 4.

Notice: This document contains references to Agilent. Please note that Agilent's Test and Measurement business has become Keysight Technologies. For more information, go to www.keysight.com.

Operating and Service Manual

Part Number 00346-90148
Printed in USA August 2014
© Copyright 2001-2014
Keysight Technologies

Notice

Information contained in this document is subject to change without notice. Agilent Technologies makes no warranty of any kind with regard to this material, including, but not limited to, the implied warranties of merchantability and fitness for a particular purpose. Agilent Technologies shall not be liable for errors contained herein or for incidental or consequential damages in connection with the furnishings, performance, or use of this material. No part of this document may be photocopied, reproduced, or translated to another language without the prior written consent of Agilent Technologies.

Certification

Agilent Technologies certifies that this product met its published specifications at the time of shipment from the factory. Agilent Technologies further certifies that its calibration measurements are traceable to the United States National Institute of Standards and Technology and/or The United Kingdom National Physics Laboratories, to the extent allowed by the Institution's calibration facility, and to the calibration facilities of other International Standards Organization members.

Warranty

This Agilent Technologies instrument product is warranted against defects in material and workmanship for a period of one year from date of shipment. During the warranty period, Agilent Technologies will at its option, either repair or replace products which prove to be defective. For warranty service or repair, this product must be returned to a service facility designated by Agilent Technologies. Buyer shall prepay shipping charges to Agilent Technologies and Agilent Technologies shall pay shipping charges, duties, and taxes for products returned to Agilent

Technologies from another country. Agilent Technologies warrants that its software and firmware designated by Agilent Technologies for use with an instrument will execute its programming instructions when properly installed on that instrument. Agilent Technologies does not warrant that the operation of the instrument, or firmware will be uninterrupted or error free.

Limitation of Warranty

The foregoing warranty shall not apply to defects resulting from improper or inadequate maintenance by Buyer, Buyer-supplied software or interfacing, unauthorized modification or misuse, operation outside of the environmental specifications for the product, or improper site preparation or maintenance. NO OTHER WARRANTY IS EXPRESSED OR IMPLIED. AGILENT TECHNOLOGIES SPECIFICALLY DISCLAIMS THE IMPLIED WARRANTIES OF MERCHANTABILITY AND FITNESS FOR A PARTICULAR PURPOSE.

Exclusive Remedies

THE REMEDIES PROVIDED HEREIN ARE BUYER'S SOLE AND EXCLUSIVE REMEDIES. AGILENT TECHNOLOGIES SHALL NOT BE LIABLE FOR ANY DIRECT, INDIRECT, SPECIAL, INCIDENTAL, OR CONSEQUENTIAL DAMAGES, WHETHER BASED ON CONTRACT, TORT, OR ANY OTHER LEGAL THEORY.

Safety Notices

This guide uses warnings and cautions to denote hazards.

WARNING

A warning calls attention to a procedure, practice or the like, which, if not correctly performed or adhered to, could result in injury or the loss of life. Do not proceed beyond a warning until the indicated conditions are fully understood and met.

CAUTION

A caution calls attention to a procedure, practice or the like, which, if not correctly performed or adhered to, could result in damage or the destruction of part or all of the equipment. Do not proceed beyond a caution until the indicated conditions are fully understood and met.

Declaration of Comformity

A copy of the Manufacturer's European Declaration of Conformity for this instrument can be obtained by contacting your local Agilent Technologies sales representative.

Table of Contents

	Page
1. General Information	
Introduction	2
Specifications	2
Instruments Covered in This Manual	9
Description	10
Model Characteristics of Individual Noise Sources	11
Warranty	12
Equipment Available But Not Supplied	12
Options	12
Installation	13
Handling Precautions	13
Initial Inspection	13
Original Packaging	14
Mating Connectors	14
Storage and Shipping Environment	14
Operation	15
Operating Environment	16
Recommended Test Equipment	16
Operator's Check	17
Operator's Maintenance	22
Performance Tests	24
Adjustments	25
Replaceable Parts	26
Replaceable Parts List	27
Service	29
Principles of Operation	29
Troubleshooting	29
Repair	30
Returning a Noise Source for Calibration	30
2. Manual Changes	
Manual Changes	34
Change A	34
3. Using the ENR Data Diskette	

Introduction	36
Loading the ENR Data from Diskette	37
Saving the ENR Data to the Noise Figure Analyzer's Internal Memory	40
Copying the ENR Data to the Noise Figure Analyzer's Internal Memory	41
4. ENR File Format	
Format Details	44
Comment Records	44
Header Fields	44
ENR Data.	46
Examples.	49
A. Caring for Connectors	
Introduction	52
Connector Part Numbers	52
Handling and Storage	52
Visual Inspection	53
Obvious Defects and Damage.	53
Mating Plane Surfaces	53
Precision 7 mm Connectors.	54
Sexed Connectors	55
Cleaning	57
Compressed Air	57
Cleaning Alcohol	57
Precision 7 mm Connectors.	58
Cleaning Interior Surfaces	59
Drying Connectors.	60
Mechanical Inspection: Connector Gages	61
Mechanical Specifications	62
Precision 7mm Connectors	62
Sexed Connectors	63
50 Ohm Type-N Connectors	63
75 Ohm Type-N Connectors	64
Using Connector Gages	65
Inspecting and Cleaning the Gage	65
Zeroing the Gage	65
Making Connections.	68
Align Connectors Carefully.	68
To Make a Preliminary Connection	69
Final Connection Using a Torque Wrench.	70
Disconnection.	71
Adapters	73
Principles of Microwave Connector Care	75

Introduction

This manual contains operating and service information for the Agilent Technologies model 346A, 346B, and 346C Noise Sources.

Included in the manual is information necessary to operate the noise sources.

Specifications

The “Specifications - Table 1-1” on page 3, page 4, and page 5 are performance standards or limits against which the noise source may be tested. These specifications for the noise source when used with a Noise Figure Analyzer are ONLY valid if the analyzer has been allowed to meet its specified warm up time of 60 minutes.

ENR expanded uncertainty analysis and supplemental characteristics are not specifications but are typical characteristics included as additional information for the user.

NOTE

Specifications are valid at ambient temperature 23 ± 1 °Celsius only.

Specifications - Table 1-1

Frequency Range

346A/B	10 MHz — 18 GHz
346C	10 MHz — 26.5 GHz

Operating Temperature

0 °C to 55 °C

Excess Noise Ratio (ENR) Range¹

346A	4.5 - 6.5 dB
346B	14- 16 dB
346C	12 - 17 dB

1. ENR values are given at cardinal frequency points over the frequency range of each noise source. Calibrated values at cardinal frequencies printed on each noise source label and on a separate report supplied with each Agilent 346 Noise Source. Specifications are valid at calibration temperature only.

Specifications - Table 1-1 Continued

**Maximum
Standing Wave
Ratio (SWR) and
Reflection
Coefficient (ρ) for
Source ON/OFF
States**

Instrument model	Frequency Range (GHz)	Maximum Standing Wave Ratio (SWR)	Reflection Coefficient (ρ) (ρ)
346A/B¹	0.01 - 0.03	<1.3:1	0.13
	0.03 - 5.0	<1.15:1	0.07
	5.0 - 18.0	<1.25:1	0.11
346C	0.01-18.0	<1.25:1	0.11
	18.0 - 26.5	<1.35:1	0.15

1. Maximum change in complex reflection coefficient between source ON and source OFF at all frequencies for 346A only: 0.01.

Specifications - Table 1-1 Continued

Impedance

50 ohm nominal

Maximum reverse power

1 Watt

Power required

28 ±1 V

346A/B	60 mA peak, 30 mA average for source ON
346C	45 mA

Connectors¹

346 Output	APC-3.5 (male) standard ¹
346 Input	Bias: BNC (f)

1. Also mates with female SMA connectors. See option information for other connector styles.

Dimensions

140 x 21 x 31mm (5.5 x 0.8 x 1.2 in)

Net Weight

0.1 kg (3.5 oz.)

1. For correct connector usage, refer Table A-2 for the torque settings.

Introduction

Excess Noise Ratio Expanded Uncertainty (U(Y)) - Table 1-2

ENR values are given at cardinal frequency points over the frequency range of each noise source. These ENR values are printed on the noise source label and on a separate printed report supplied with the 346 Noise Source. Included in the printed report is the measurement uncertainty for each cardinal frequency point.

A significant proportion of the expanded uncertainty (U(Y)) is based on the uncertainties provided by the United States National Institute of Standards and Technology (NIST) and/or The United Kingdom National Physics Laboratories (NPL). Agilent therefore reserve the right to change the overall expanded uncertainties based on changes in uncertainty values within the National Standards Institutes.

Uncertainties are valid at ambient temperature 23°C ±1°C (296K) only.

A typical characteristic plot of ENR (U(Y)) versus each cardinal frequency point is shown in Figure 1-1. the uncertainties given are typical - refer to the printed calibration report for the actual uncertainties for your noise source.

Figure 1-1 Characteristic¹ENR Plot versus Cardinal Frequency Points

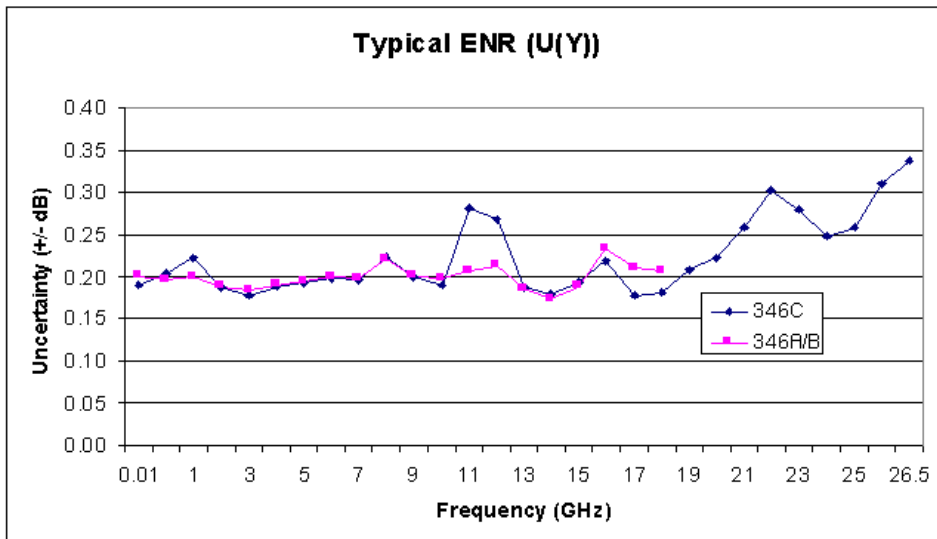

1. Characteristic values are met or bettered by 90% of instruments with 90% confidence.

**Excess Noise Ratio Expanded Uncertainty (U(Y)) - Table 1-2
Continued**

**Characteristic
ENR (U(Y))
Specification**

Instrument model	Frequency (GHz)	ENR Uncertainty (\pmdB)¹
346A	0.01- 1.5	0.21
	1.5 - 3.0	0.20
	3.0 - 7.0	0.20
	7.0 - 18.0	0.23
346B	0.01- 1.5	0.20
	1.5 - 3.0	0.19
	3.0 - 7.0	0.20
	7.0 - 18.0	0.23
346C	0.01- 1.5	0.22
	1.5 - 3.0	0.19
	3.0 - 7.0	0.20
	7.0 - 18.0	0.28
	18.0 - 26.5	0.34

1. Characteristic values are met or bettered by 90% of instruments with 90% confidence.

Supplemental Characteristics - Table 1-3**Supplemental
Characteristics**

ENR variation with temperature:	<0.01 dB/°C for 30 MHz to 26.5 GHz
ENR variation with voltage:	Internal current regulator for <0.02 dB variation for 28 ±1 V
Switching speed:	
For repetitive operation (in previous state for less than 5 seconds):	
	Turn-on: < 20 μs
	Turn-off: <80 μs
For single-shot operation (in previous state more than 5 seconds):	
	Turn-on: < 3 ms
	Turn-off: <80 μs

Instruments Covered in This Manual

The noise sources covered by this manual have a two-part serial number. The first four digits and letter constitute the serial number prefix. The last five digits form a sequential suffix that is unique to each noise source. The prefix is the same for all noise sources of a particular configuration. It will change when a design modification occurs. The contents of this manual apply directly to those instruments having the same serial number prefixes listed under SERIAL NUMBERS on the title page.

A noise source manufactured after the printing of this manual may have a serial number prefix which is not listed on the title page. This unlisted serial number prefix indicates the noise source is different than those documented in this manual. If manual changes are needed, the manual for this newer noise source is accompanied by a Manual Changes supplement. The supplement contains "change information" that explains how to adapt this manual to the newer noise source.

In addition to change information, the supplement may contain information for correcting errors in the manual. The supplement is identified with the manual print date and part number, both of which appear on the manual title page.

For information concerning a serial number prefix that is not listed on the title page in the Manual Change supplement, contact your nearest Agilent Technologies office.

Agilent/Hewlett-Packard 346 Noise Sources which were manufactured before the printing of this manual will have a serial number prefix lower than the one listed on the title page. Manual changes for these older models are found in Chapter 2 "Manual Changes".

NOTE

Agilent Technologies are migrating their existing product serial numbers to a new format. All new products use this new format. The format is the first two letters signify the country of manufacture, for example, US representing the USA, the next four numbers, the serial number prefix, and the last five numbers form a sequential suffix that is unique to each product. For example, US123456789, where 1234 is the prefix and 56789 is the suffix. The two letters MY represent Malaysia.

Description

The noise source produces noise output (power-on) when +28 V is applied. When it is off, there is residual noise due to thermal agitation in the noise source (power-off). These two noise levels are used to measure the gain and added noise of the device under test, and consequently, its noise figure.

The Excess Noise Ratio (ENR) for each noise source has been measured at major frequencies and recorded on a label attached to the noise source (see Figure 1-2). ENR references power-on to the noise power that exists at 290 Kelvin (17 °C). In addition, a separate calibration sheet showing the complex reflection coefficient in both the on and off states is included with each instrument.

All three models are provided with a BNC female connector for power input. The output connector is a male APC-3.5 on the standard noise sources. Type-N and APC-7 connectors are available as options for the Agilent 346A and 346B Noise Sources. In addition to these general characteristics, certain characteristics apply to the specific models. These characteristics are listed in Table 1-4.

Figure 1-2

A Partial View of Typical Calibration Label

FREQ GHz	ENR dB
.01	12.90
.10	13.34
1.0	13.09
2.0	13.29
3.0	13.22
4.0	13.38
5.0	13.59
6.0	13.81
7.0	13.98
8.0	14.27
9.0	14.44

ab84c

Table 1-4 Model Characteristics of Individual Noise Sources

Agilent 346A	Agilent 346B	Agilent 346C
Reflection coefficient differential between on and off states is specified to be no greater than 0.01.	Reflection coefficient differential between on and off states is not specified, but is less than 0.1 typically.	Reflection coefficient differential between on and off states is not specified, but is less than 0.1 typically.
Specified output noise spectrum from 10 MHz to 18 GHz.	Specified output noise spectrum from 10 MHz to 18 GHz.	Specified output noise spectrum from 10 MHz to 26.5 GHz.
Nominal ENR is 6 dB over the specified frequency range.	Nominal ENR is 15 dB over the specified frequency range.	Nominal ENR is 15 dB over the specified frequency range.
Not directly usable for Agilent/HP 8970A IF attenuator calibration (Special Function 33). 10 dB of gain is required.	Suitable for Agilent/HP 8970A IF attenuator calibration (Special Function 33).	Suitable for Agilent/HP 8970A IF attenuator calibration (Special Function 33).
Not directly usable for Agilent/HP 8970B IF attenuator calibration. Refer to "Calibration, IF Attenuators" in the <i>Agilent / HP 8970B Operating Manual</i> .	Suitable for Agilent/HP 8970B IF attenuator calibration. Refer to "Calibration, IF Attenuators" in the <i>Agilent/HP 8970B Operating Manual</i> .	Suitable for Agilent/HP 8970B IF attenuator calibration. Refer to "Calibration, IF Attenuators" in the <i>Agilent/HP 8970B Operating Manual</i> .

Description

Warranty

The noise sources are warranted and certified as indicated in this manual. Connector damage resulting from improper use is not covered under warranty.

Equipment Available But Not Supplied

The following equipment is available from Agilent Technologies for use with the noise sources:

- 8710-1766: 3/4" Torque Wrench (APC-7)
- 5060-0344: 9/16" Torque Wrench (APC-3.5)

NOTE

Agilent/HP Model 346B Noise Sources with serial prefixes of 2037A and below, have an APC-3.5 connector of a different configuration (See Figure 1-3). The 9/16" torque wrench will not fit these older models.

Figure 1-3

Agilent/HP Noise source with Older APC-3.5 Connector

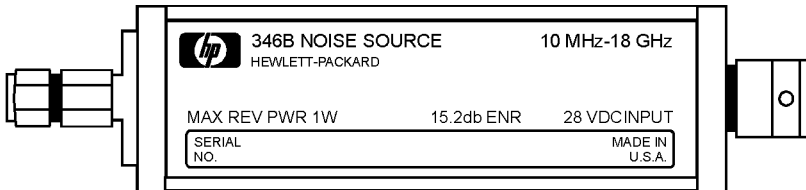

Options

The Agilent 346A and 346B Noise Sources are available with the following output connector options:

- Option 001, Type-N (male)
- Option 002, APC-7
- Option 004, Type-N (female)

Since the APC-7 and Type-N connectors do not operate up to 26.5 GHz, no output connector options are available for the Agilent 346C.

Installation

Handling Precautions

CAUTION

Do not disassemble the noise source. The diode module is static sensitive and can be damaged or the calibration can be altered.

CAUTION

Do not drop the noise source. Dropping can damage the unit or alter the calibration.

Proper connector care is essential. See *Operator's Maintenance* in the *Operation* section of this manual for more information.

Initial Inspection

Inspect the shipping container for damage. Inspect the noise source for mechanical damage incurred in transit. If the shipping container or cushioning material is damaged, it should be kept until the contents of the shipment have been checked for completeness and the noise source has been mechanically and electrically checked. If the contents are incomplete, if there is mechanical damage or a defect, or if the noise source does not work electrically, notify the nearest Agilent Technologies office. If the shipping container is damaged, or the cushioning material shows signs of unusual stress, notify the carrier as well as the Agilent Technologies office. Keep the shipping materials for the carrier's inspection.

Original Packaging

Container and materials identical to those used in factory packaging are available through Agilent Technologies offices. If the noise source is being returned to Agilent Technologies for servicing, attach a tag indicating the name and address of the company, the technical contact person, phone number and extension, the model number, serial number, type of service being requested, and failure symptoms if applicable. Mark the shipping container FRAGILE. In any correspondence, refer to the noise sources by model number and serial number.

Mating Connectors

The noise sources can be mated with other instrumentation having the connectors listed in Table 1-5.

Table 1-5**Connectors That Can Be Mated With the Noise Sources**

Configuration	Mating Connector
Input: all units	BNC male ¹
Output: standard	APC-3.5 female SMA female
Opt.001	Type-N female ¹
Opt.002	APC-7
Opt.004	Type-N male ¹
¹ Must comply with U.S. Military Standard MII,C-39012	

Storage and Shipping Environment

The noise sources should be stored in a clean, dry environment. The following environmental limitations apply to both storage and shipment:

- Temperature: -55 °C to +75 °C
- Humidity: <95% relative
- Altitude: <15300 meters (50000 feet)

Operation

This section refers to operation with noise figure meters. For more detailed operating instructions, refer to the operating manual for the noise figure meter used.

CAUTION

Use a dc blocking capacitor to protect the noise source from damage when connected to any system where a dc voltage is present on the output center conductor.

Noise figure measurements of devices (such as amplifiers, mixers, transistors, and receivers) can be made using the noise source with a noise figure meter. Figure 1-4 depicts a simple test setup for a noise figure measurement.

NOTE

The noise figure meter must have a $+28 \pm 1$ V switched supply.

Figure 1-4 Typical Noise Figure Measurement Test Setup

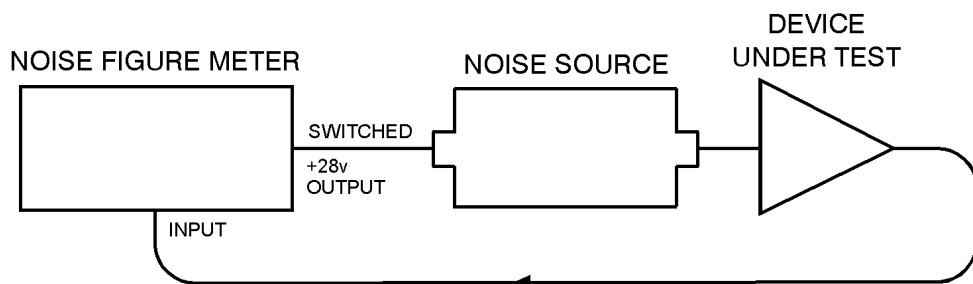

ab86c

Operation

Operating Environment

The operating environment of the noise sources should be within the following limitations:

- Temperature: 0 °C to +55 °C
- Humidity: <95% relative
- Altitude: <4600 metres (15 000 feet)

Recommended Test Equipment

Table 1-6 is a list of equipment that can be used to perform an operational verification check.

Table 1-6 Recommended Test Equipment For Operator’s Checks

Check No.	Instrument	Critical Specification	Recommended Model
1	Power Meter and Power Sensor	Minimum Sensitivity: 0.1 nW Frequency Range: 10 MHz to 18 GHz	Agilent/HP E4418A with Agilent/HP 8481D, or E4412A, or E9300A
	Power Supply	Voltage: 28.0 ±1.0 V Current: 100 mA	Agilent/HP 6028A
2	Noise Figure Meter	Voltage Output: 28.0 ±1.0 V Input Noise Figure: <7.4 FdB at 100 MHz	Agilent/HP 8970B or Agilent N8972/3/4/5A

Operator's Check

The operator's checks in this section should be performed if failure of the noise source is suspected. The checks can be used only to verify that the noise sources are producing a broadband noise spectrum. They cannot be used to check the units against specifications. Only one of the checks is necessary to verify operation. Table 1-6 shows the recommended test equipment used for each check.

Operator's Check with Power Meter (Check 1)

Step 1. Connect the equipment as shown in Figure 1-5.

Figure 1-5 **Operator's Check Test Setup 1**

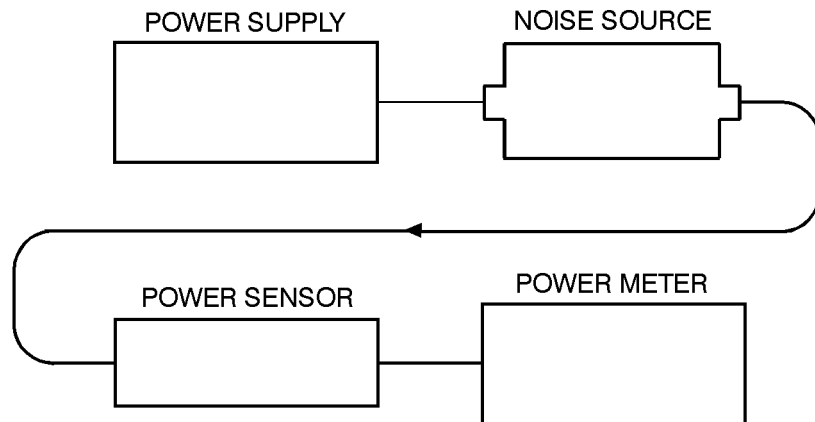

ab82c

Step 2. Turn the power supply OFF. Zero the power meter.

Step 3. Turn the power supply ON (+28 V). Measure the power output with the noise source on.

Step 4. Verify that the result of the measurement is within the following limits and hence the noise source is operating correctly:

- Agilent 346A Power output = -66 ± 4 dBm.
- Agilent 346B Power output = -56 ± 4 dBm.
- Agilent 346C Power output = -56 ± 4 dBm.

General Information
Operation

Operator's Check with Agilent/HP 8970B Noise Figure Meter (Check 2a)

- Step 1.** Remove any cables from the noise figure meter input. Press **PRESET**. After 5 seconds, verify the noise figure display shows **--FdB** and the left display shows **30 MHz**.
- Step 2.** Connect the equipment as shown in Figure 1-6.

Figure 1-6 **Operator's Check Test Setup 2a**

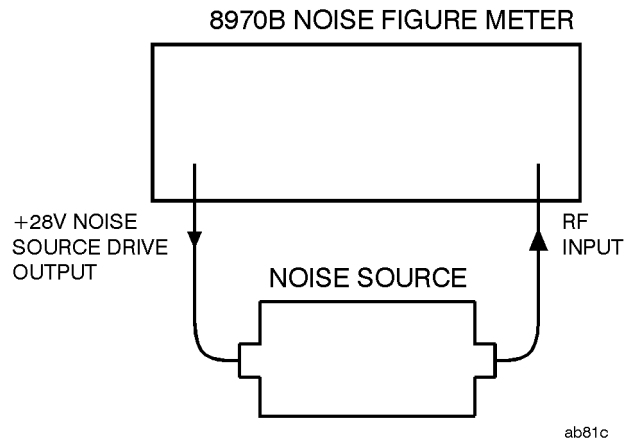

- Step 3.** Enter a tuned frequency of 100 MHz. (See "Fixed Frequency Tuning" in the Agilent/HP 8970B Operating Manual).
- Step 4.** Enter special function 5.3 to enable the instrument for spot ENR entry. (See "Special Functions" in the Agilent/HP 8970B Operating Manual).
- Step 5.** Enter the ENR at 100 MHz from the noise source calibration label. (See "Spot ENR, T_{hot} , and T_{Cold} , in the Agilent/HP 8970B Operating Manual).
- Step 6.** Confirm that the noise source is operating correctly.
- The noise figure measurement of the noise figure meter will appear in the noise figure display. If the result of the measurement is less than **7.4 FdB**, the noise source is operating.
- Step 7.** Press **PRESET** to return the instrument to preset conditions.

Operator's Check with Agilent N8972/3/4/5AB Noise Figure Analyzer (Check 2b)

Step 1. Remove any cables from the NFA input and the noise source drive.

Step 2. Press the **Preset** key.

Wait until the preset routine has completed before proceeding.

NOTE

The preset condition used is the NFA default of **Preset (Factory)**.

Step 3. Connect the 346A/B/C to the NFA Input port using a BNC cable, as shown in Figure 1-7.

Figure 1-7 **Operator's Check Test Setup 2b**



Step 4. Press the **ENR** key.

Step 5. Press the **ENR Table** menu key.

Step 6. Press the **Edit Table** menu key.

Step 7. Press the **Clear Table** menu key.

Step 8. Enter 100 MHz in the Frequency column of the table: Press **1,0,0** on the numeric keypad followed by the **MHz** menu key.

General Information
Operation

- Step 9.** Press the **Tab** key to highlight the ENR Value column of the table.
- Step 10.** Enter the ENR value of the 346A/B/C at 100 MHz (0.1 GHz) using the numeric keypad followed by the **dB** menu key.
- Step 11.** Press the **Frequency/Points** key.
- Step 12.** Press the **Frequency Mode** menu key.
- Step 13.** Press the **Fixed** menu key.
- Step 14.** Press the **Fixed Frequency** menu key.
- Enter 100 MHz as a fixed frequency value, by pressing the 1, 0, 0 numeric keys followed by pressing the **MHz** menu key.
- Step 15.** Press the **Sweep** key.
- Step 16.** Press the **Manual Meas** menu key.
- Step 17.** Press the **Manual State** menu key and set it to **Manual State (On)**.
- Step 18.** Press the **Noise Source** menu key and set it to **Noise Source (On)**.
- Step 19.** Press the **IF Att** menu key and set it to **IF Att (Hold)**.
- Step 20.** Monitor the power value which appears in the manual measurement screen. Figure 1-8 shows a typical example of this.

Figure 1-8 Typical example of power reading with Noise Source On

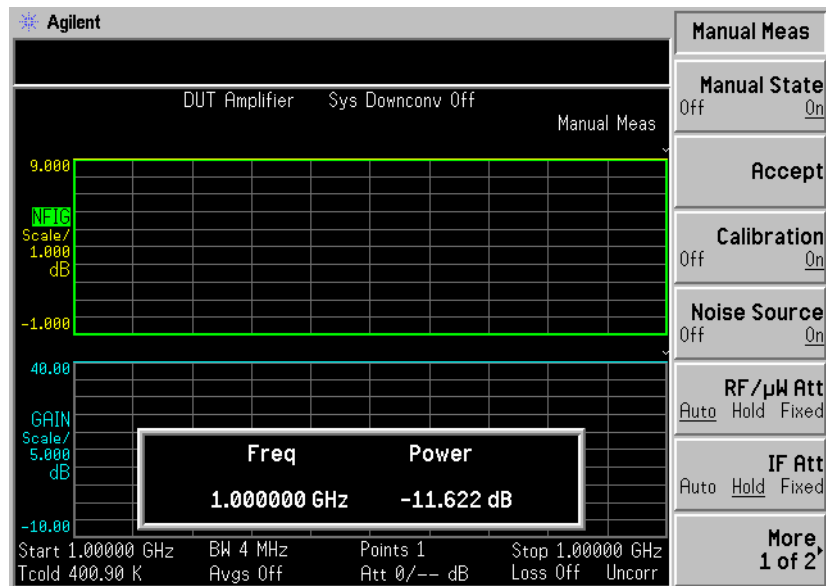

Step 21. Press the **Noise Source** menu key and set it to **Noise Source (Off)**.

Step 22. Monitor the power value which appears in the manual measurement screen. Figure 1-9 shows a typical example of this.

NOTE

The monitored value is only to be used to indicate if the 346A/B/C is switching the Excess Noise “On” and “Off” by showing a change in power value.

Figure 1-9

Typical example of power reading with Noise Source Off

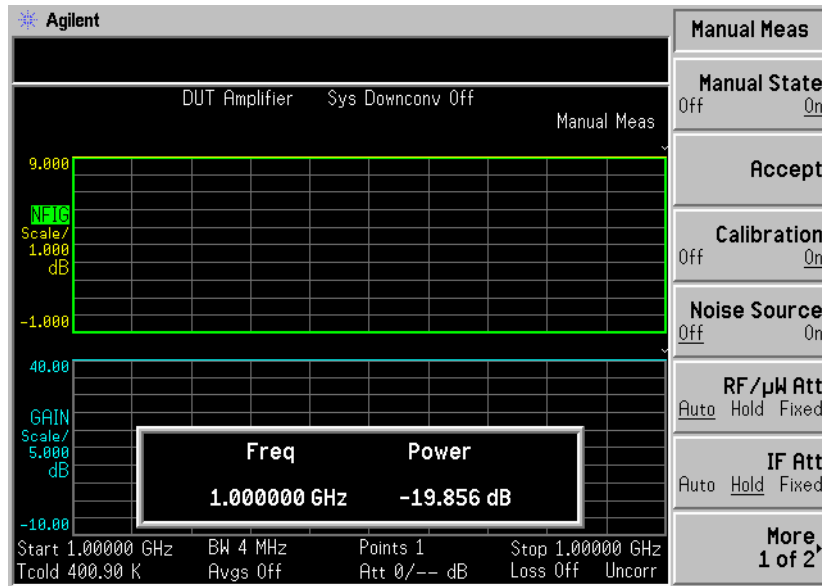

Step 23. If there is not a change in value, return the 346A/B/C to Agilent Technologies for repair.

Operator's Maintenance

Proper connector care is a vital part of the maintenance which should be performed by the user. By following the general connector care practices outlined below, the life of the connector can be greatly extended.

- Connectors should be properly torqued as shown below.

Connector Type	Torque Specifications
N	1.3 N m (12 in.-lb.)
APC-7	1.3 N m (12 in.-lb.)
SMA to APC-3.5	0.9 N m (8 in.-lb.)
APC-3.5 to APC-3.5	0.9 N m (8 in.-lb.)

- Always tighten or loosen a connector by rotating only the nut. Never rotate the noise source body.

- Use isopropyl or ethyl alcohol on a swab to clean connectors. Absorbent, lint-free paper wrapped around the end of tweezers is recommended. Carefully clean the conductive surfaces and avoid wetting the plastic parts inside the connector with alcohol. After cleaning, be sure connector is blown dry before re-assembly.
- It is good practice to inspect a connector after cleaning. During the inspection, check for contaminants and worn plating. Also check for a misaligned center conductor or spread fingers on the APC-3.5 or Type-N connectors.
- Support the cable or component attached to the connector.
- When using APC-7 connectors, the nut of one connector should always be backed off completely and the nut on the mating connector should be tightened. Never set an APC-7 connector on its mating surface. Before storage, always screw the nut out to protect the surfaces.
- Be sure the connectors are axially aligned before the nut is tightened.
- Use a connector gauge periodically to check the center pin depth. The shoulder of the center conductor must never extend beyond the plane of the outer conductor mating surface in an APC-3.5 connector.
- For more information, refer to Appendix A , “Caring for Connectors,” on page 51.

Performance Tests

Due to the complex test equipment involved, there are no recommended performance tests for the user to perform. Return the noise sources to Agilent Technologies when tests are required to verify its performance and for periodic re-calibration. The suggested interval before initial re-calibration is one year.

Adjustments

There are no adjustments that can be made on the noise sources by the user.

Replaceable Parts

Table 1-7 lists all replaceable parts available for the Agilent 346A/B/C Noise Sources. Figure 1-10 shows a typical Noise Source being prepared for parts replacement at modular level by removing the four end screws (two at each end).

NOTE

If the Agilent 346A/B/C is opened and parts replaced, the Noise Source will require calibration.

NOTE

Due to a parts change, adjustment of the bias current may be necessary for the product to meet its ENR specifications when parts are replaced in older units. Installation Note 00346-90137 details the adjustment process for the 346A and 346B. Installation Note 00346-90140 details the adjustment process for the 346C. Both are supplied with their appropriate replacement parts.

To order parts contact your local Agilent Technologies Sales and Service Office.

Table 1-7 Replaceable Parts List

Agilent Part Numbers				
Model/Option	Bulkhead RF Replacement	Replacement Noise Cartridge Assy	Replacement Attenuator Assy	Replacement PC Board Assy
346B Std	00346-60026	00346-60154	00346-60027	00346-60157
Option 001	00346-60018	00346-60154	00346-60027	00346-60157
Option 002	00346-60019	00346-60154	00346-60027	00346-60157
Option 004	00346-60020	00346-60154	00346-60027	00346-60157
346C Std	00346-60021	00346-60155	00346-60027	00346-60158

Model/Option	Bulkhead RF	Noise Cartridge Kit (Serial Prefix \leq MY/SG/US5322)	Noise Cartridge Kit (Serial Prefix \geq MY/SG/US5323)	Attenuator Kit	PC Board
346A Std	00346-60168	00346-60194	00346-60193	00346-60194	00346-60157
Option 001	00346-60169	00346-60194	00346-60193	00346-60194	00346-60157
Option 002	00346-60170	00346-60194	00346-60193	00346-60194	00346-60157
Option 004	00346-60171	00346-60194	00346-60193	00346-60194	00346-60157

Table 1-8 Replaceable Labels List

Part Number	Label Descriptions
00346-80006	346A Label Caution
00346-80007	346BA Label Caution
00346-80008	346C Label Noise
00346-80012	Label - Blank ENR

Figure 1-10 **Preparing for Parts Removal/Replacement**

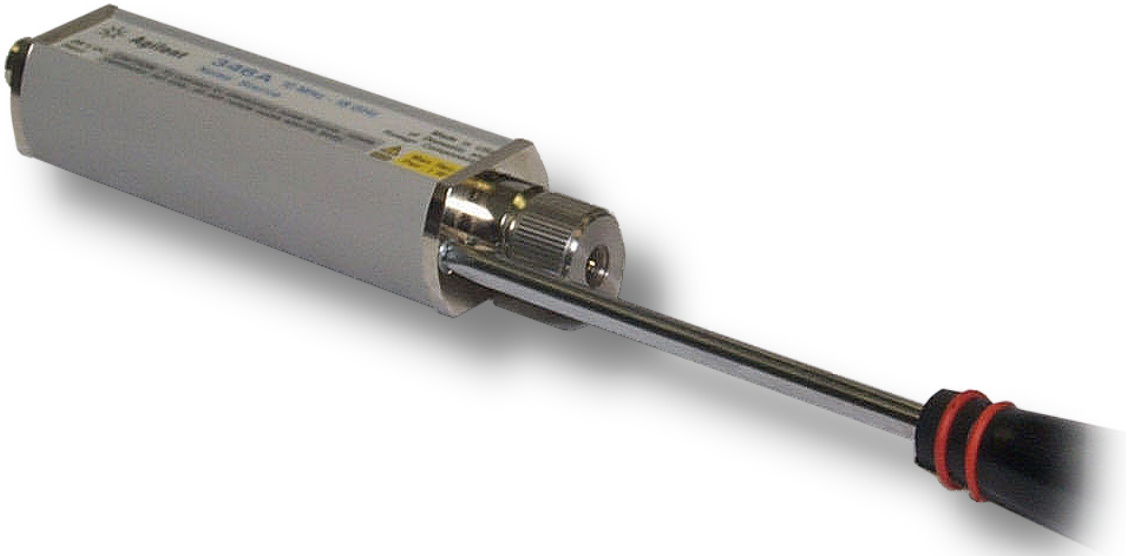

Service

Principles of Operation

Figure 1-11 shows a simplified diagram of the noise source. When driven by a +28V pulse, the 346 produces an output noise spectrum with an ENR of approximately 5.0 dB for the 346A and approximately 15.0 dB for the 346B and 346C. The noise generator is an avalanche diode positioned into a 50 ohm system. The noise source is divided into a dc section including a voltage converter and a current regulator, and an RF section which includes the noise generator, a matching network and an attenuator.

The +28 volts supplies a 5.6 kHz oscillator which is rectified as the supply for the constant current source to produce a controlled noise level output. The current regulator controls through the noise generator diode producing a known level of broadband noise that is constant for a supply voltage of 27 to 29 volts.

Figure 1-11 Simplified Diagram of the Noise Source

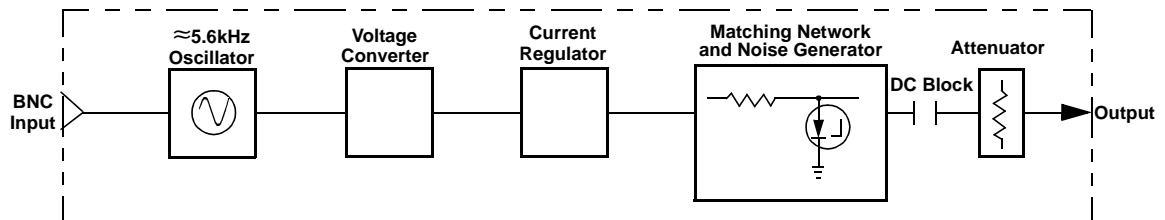

Troubleshooting

Check the connectors. If there is no apparent damage to the connectors, perform one of the operator's checks described in the Operation section of this manual. If the noise source's output does not fall within the stated range, or if the connectors are damaged, return the unit to Agilent Technologies for repair.

Service

Repair

Repair by the user is not recommended because of the complex equipment required for test and calibration.

Returning a Noise Source for Calibration

When returning a 346 or Noise Source to Agilent Technologies for repair or calibration, please specify whether an ENR Data Diskette is needed. When the 346 is used with an Agilent Noise Figure Analyzer NFA, the ENR Data Diskette is used to automatically load the ENR values into memory.

When the 346 is used with an 8970A/B Noise Figure Meter, you must enter the ENR values manually, and the ENR Data Diskette is not necessary.

Table 1-9

Agilent Technologies Sales and Service Offices

UNITED STATES
Agilent Technologies (tel) 1 800 452 4844
CANADA
Agilent Technologies Canada Inc. Test & Measurement (tel) 1 877 894 4414
EUROPE
Agilent Technologies Test & Measurement European Marketing Organization (tel) (31 20) 547 2000
JAPAN
Agilent Technologies Japan Ltd. (tel) (81) 426 56 7832 (fax) (81) 426 56 7840
LATIN AMERICA
Agilent Technologies Latin America Region Headquarters, USA (tel) (305) 267 4245 (fax) (305) 267 4286
AUSTRALIA/NEW ZEALAND
Agilent Technologies Australia Pty Ltd. (tel) 1-800 629 4852 (Australia) (fax) (61 3) 9272 0749 (Australia) (tel) 0-800 738 378 (New Zealand) (fax) (64 4) 802 6881 (New Zealand)
ASIA PACIFIC
Agilent Technologies, Hong Kong (tel) (852) 3197 7777 (fax) (852) 2506 9284

2 **Manual Changes**

This chapter contains information for adapting this manual to Agilent/HP 346B Noise Sources with serial number prefixes of 2015A and 1935A.

Manual Changes

To adapt this manual to your instrument, refer to Table 2-1. Make all of the manual changes listed opposite your instrument's serial number prefix. Perform these changes in the sequence listed.

Table 2-1 Manual Changes by Serial Number

Instrument	Serial Number Prefix	Make Manual Changes
346B	1935A, 2015A	A

If your instrument (all models) has a serial number prefix which is higher in value than those listed on the title page of this manual, it may be documented in a yellow MANUAL CHANGES supplement. For additional information, refer to "Instruments Covered by Manual" in the General Information section of this manual.

Change A

Table 1-2 Supplemental Characteristics

Change Switching Speed for both repetitive operation and single shot operation to read: Turn off <140 μ s.

Introduction

The Agilent 346 and 347 series of Noise Sources are supplied with the noise source ENR data preloaded on diskette to allow easy downloading into the Agilent NFA series Noise Figure Analyzers. This eliminates time consuming and error prone manual keying of the ENR values.

Additionally you can easily open the ENR files using a standard text editor and the files are easy to interpret and create.

This chapter covers the following:

- Loading the ENR Data from Diskette
- Saving the ENR Data to the Noise Figure Analyzer's Internal Memory
- Copying the ENR Data from Diskette to the Noise Figure Analyzer's Internal Memory

NOTE

The following procedures do not apply to noise sources used with the Agilent 8970A/B Noise Figure Meter.

You must enter ENR values manually into the 8970A/B.

Loading the ENR Data from Diskette

To load the ENR data from the diskette and use the data as the current ENR table, proceed as follows:

- Step 1.** Power up the Noise Figure Analyzer and wait for the power-up sequence to complete.
- Step 2.** Insert the diskette into the floppy drive of the Noise Figure Analyzer.

NOTE

Do not insert the diskette into the Noise Figure Analyzer until the power-up sequence is complete.

- Step 3.** On the Noise Figure Analyzer, press the **File** key and press the **Load** menu key to access the file system.
- Step 4.** Press the **ENR** menu key and select whether the ENR table is a **Meas Table** (used for measurements) or a **Cal Table** (used for calibration). If you intend to use the same ENR table for calibration and measurement, then set the ENR table as **Meas Table**.

The Noise Figure Analyzer allows you to use the same or separate ENR tables for calibration and measurement as required. For more details on specifying **Meas Table** and **Cal Table**, see the *Noise Figure Analyzer User's Guide*.

- Step 5.** Press the **Select** menu key and use the arrow keys if necessary to highlight [-A-]. If C: is the currently selected drive use the ". ." directory to reach the A: drive as directed on the screen. Press the **Select** menu key again to read the diskette.
- Step 6.** Use the down arrow key (↓) to highlight the ENR file and press the **Enter** key to load it.

When the file is successfully loaded a message, for example
A:A0100364.ENR file loaded appears on the display.

Note that ENR files with a large number of frequency points (for example, up to 50 GHz) may take a few seconds to load.

Using the ENR Data Diskette
Loading the ENR Data from Diskette

ENR filename format

The ENR filename of the ENR file stored on the diskette, for example A0100123.enr, has the following format:

- The first letter shows the noise source type and can be:
 - A = 346A
 - B = 346B
 - C = 346C
 - R = R347A
 - Q = Q347A
- The next four digits, for example 0100, show the calibration date. For example 0100 shows a calibration date of January 2000.
- The last three digits, for example 123, are the last 3 digits of the serial number of the Noise Source.
- The file extension is .enr to indicate ENR file format.

Once the ENR file is loaded from diskette, to verify that the ENR data is correct, press the **ENR** key, then press the **ENR Table>** menu item to display the ENR table.

The screenshot shows a software interface for displaying ENR data. On the left, there are two input fields: 'Noise Source Serial Number' with the value '3318A15364' and 'Noise Source Model ID' with the value '346B'. In the center, a table lists frequencies and their corresponding ENR values. The first row is highlighted in yellow. On the right, a vertical menu contains several options: 'ENR Table', 'Edit Table>', 'Serial Number>', and 'ID>'. At the bottom of the interface, a note reads: 'Use 'File' key to Load or Save a table.'

Frequency	ENR Value
10.0000000 MHz	15.281 dB
100.000000 MHz	15.291 dB
1.00000000 GHz	15.118 dB
2.00000000 GHz	14.999 dB
3.00000000 GHz	14.879 dB
4.00000000 GHz	14.795 dB
5.00000000 GHz	14.818 dB
6.00000000 GHz	14.846 dB
7.00000000 GHz	14.895 dB
8.00000000 GHz	15.016 dB
9.00000000 GHz	15.134 dB
10.0000000 GHz	15.253 dB
11.0000000 GHz	15.249 dB
12.0000000 GHz	15.349 dB
13.0000000 GHz	15.383 dB

Confirm that the Noise Source Serial Number and the Noise Source

Model ID are correct and compare the Frequency and ENR values with the supplied Calibration Sheet or the data printed on the body of the Noise Source.

Saving the ENR Data to the Noise Figure Analyzer's Internal Memory

To save the current Noise Source ENR data from the diskette (A: drive) to the Noise Figure Analyzer's internal memory (C: drive) proceed as follows:

- Step 1.** Load the ENR table as described in "Loading the ENR Data from Diskette" on page 37.
- Step 2.** Press the **File** key and press the **Save** menu key.
- Step 3.** The ENR menu key indicates whether the file is currently loaded as a measurement table (**Meas Table**) or a calibration table (**Cal Table**). Press the **ENR** menu key and select whether you want to store the ENR table as a **Meas Table** or a **Cal Table**. If you intend to use the same common ENR table for calibration and measurement, then set the ENR table as **Meas Table**.

The Noise Figure Analyzer allows you to use the same or separate ENR tables for calibration and measurement as required. For more details on using ENR tables see the *Noise Figure Analyzer User's Guide*.

When the ENR table is selected, the **Alpha Editor** is now presented to you, allowing you to specify a name for the file. If required you can use the numeric keypad to enter numbers in the filename. Note that you can also use the default filename which is in the format `TSTxxxx` where x is a sequentially allocated number. For details of the filename format used for the ENR data supplied on the diskette, see "ENR filename format" on page 38.

- Step 4.** Input the name of the ENR table using the **Alpha Editor** and numeric keypad. Use the **Tab** key to move to the ". . ": field.
- Step 5.** If the `To: Path:` field is currently `A:`, press the **Select** menu key and use the arrow key to highlight `[-C-]`, then press the **Select** menu key again. With the `To: Path:` field set to `C:` press **Enter** to save the file with the specified filename.

When the file is successfully saved, a message, for example:
`C:A0100364.ENR file saved` appears on the status line of the display.

Copying the ENR Data to the Noise Figure Analyzer's Internal Memory

To copy the Noise Source ENR data from the diskette (A: drive) to the Noise Figure Analyzer's internal memory (C: drive) proceed as follows:

- Step 1.** Power up the Noise Figure Analyzer and wait for the power-up sequence to complete.
- Step 2.** Insert the diskette into the floppy drive of the Noise Figure Analyzer.

NOTE

Do not insert the diskette into the Noise Figure Analyzer until the power-up sequence is complete.

- Step 3.** Press the **File** key and press the **File Manager** menu key.
- Step 4.** Press the **Copy>** menu key.
The file system is now presented to you.
- Step 5.** Press the **ENR** menu key to set the file type and format to ENR.
- Step 6.** Set the **From: Path:** field to **A:**, use the down arrow key (↓) to highlight the ENR file and the **Select** key to select it for copying.
The filename you are going to copy now appears in the **From: Name:** field.
- Step 7.** Press the **Tab** key to navigate to the **To: Path:** field and ensure it is set to **C:**
- Step 8.** Press the **Enter** key to copy the selected file from the diskette (A:) to the Noise Figure Analyzer's internal memory (C:).

When the file is successfully copied a message, for example
A:A0100364.ENR file copied appears on the status line of the display.
For details on the ENR filename format, see "ENR filename format" on page 38.

4 ENR File Format

Format Details

An ENR file:

- includes all data currently supplied on the printed noise source Calibration Certificate
- can be viewed and edited using a standard text editor (for example Notepad)
- is simple to create and interpret
- is easily printable
- is easily imported into Excel

The ENR file is read line by line. Each line is terminated by either a linefeed character, or a carriage-return, linefeed pair. Each line must be less than 100 characters long, excluding the terminator.

Lines containing only whitespace (tab or space character) are ignored. Each line is interpreted as one of three types of record:

- Comment
- Header Field
- ENR Data

Comment Records

A comment record must have either a '#' or '!' as the first character in the line. The entire line is ignored. Comment records can appear at any point within the file.

Header Fields

General form

Header fields must have a '[' as the first character in the line. Each header field has the general form:

- [FieldName OptionalValue]
- The '[' must be the first character on the line.
- The fieldname and optionalvalue, if present, must be separated by

whitespace.

- Whitespace following the ']' is ignored.
- The file must start with one or more header fields (ignoring comments and blank lines).

All header fields must appear at the beginning of the file before the ENR data records. Mixing header fields and ENR data is not permitted.

Mandatory header fields Certain header fields must be present. These are:

Table 4-1 Mandatory header fields

Fieldname	Description	Optional Value	Description	Example
Filetype	Indicates the type of file.	ENR	Only 'ENR' is allowed for ENR data files.	[Filetype ENR]
Version	Indicates the version of the file format which applies to this file.	versionnumber (formatted as major.minor)	Allows for future changes in the file format.	[Version 1.0]

NOTE All mandatory fields must appear in the file before any optional header fields.

Optional header fields The following header fields are also allowed. Note that only the first two, Serialnumber and Model are currently used by the Noise Figure Analyzer.

Table 4-2 Optional header fields

Fieldname	Description	Optional-Value	Description	Example
Serialnumber	the serial number of the noise source	serialtext	a string containing the serial number	[Serialnumber 3318A14223]

ENR File Format
Format Details

Table 4-2 Optional header fields

Fieldname	Description	Optional-Value	Description	Example
Model	identifies the noise source model number	modelcode	model code string	[Model 346B]
Option	Identifies any model code option	optioncode	option code string	[Option 001]
Caldate	date of calibration of noise source	date&time	formatted date and optional time	[Caldate 19991202.09:15:30]
Calduedate	indicates date when next calibration of noise source is due	date&time	formatted date and optional time	[Calduedate 20001225]
Temperature	calibration temperature	value	number followed by unit. Valid units are C,F,K	[Temperature 24C]
Humidity	calibration relative humidity	value	number followed by optional '%'	[Humidity 40%]

The format of date&time parameters is YYYYMMDD[.hh:mm:ss], i.e. a four digit year, two digit month and two digit date, optionally followed by a '.' then two digit hour ':' two digit minutes ':' two digit seconds.

Unknown header fields are ignored by the Noise Figure Analyzer. This allows for future expansion.

ENR Data

ENR data records must be ordered from lowest to highest frequency.

General form

The Noise Figure Analyzer attempts to interpret lines which are not

comments or header fields as ENR data. ENR data has the general form:

```
Freq [Funit] ENR [Eunit] [Euncert [on_mag on_phase  
off_mag off_phase [Runcert]]]
```

Note that the square brackets denote optional fields.

- Field separator** Each field is separated by whitespace. A single ' ' is allowed within or instead of the whitespace.
- Numeric fields** With the exception of the two optional unit fields, the other fields are numeric. Numbers are formatted as an optional sign, followed by a sequence of one or more digits (which can include a single decimal point within the sequence), followed by an optional exponent. The exponent consists of the 'e' or 'E' followed by an optional sign followed by between one and three digits.
- Frequency fields** The frequency field (`Freq`) is the frequency at which the ENR amplitude was measured.
- The frequency unit field (`Funit`) is optional. The default unit is Hz.
- Valid units are Hz, kHz, MHz, GHz, THz. Units are not case sensitive.
- ENR fields** The ENR amplitude (`ENR`) is the measured ENR at the specified frequency.
- The ENR unit field (`Eunit`) is optional. The default unit is dB. Currently, the only allowed unit is dB. Note that units K, C, F (temperature) are reserved for possible future use, but are not supported by the Noise Figure Analyzer at this time.
- The uncertainty field for the ENR amplitude (`Euncert`) is optional. However, this field must be present if reflection coefficient data is supplied.

Format Details

**Reflection
coefficient data**

The reflection coefficient data is optional and is formatted as four fields (`on_mag`, `on_phase`, `off_mag`, `off_phase`):

- reflection magnitude with noise source on
- reflection angle (in degrees) with noise source on
- reflection angle with noise source off
- reflection angle (degrees) with noise source off

If any reflection coefficient data is supplied, then all four fields must be present. Note that the file format requires that the ENR uncertainty field must be present before any reflection data.

The reflection coefficient uncertainty (`Runcert`) is an optional parameter. Reflection coefficient data must be present if this field is supplied.

Examples

Example 1

This first example shows a simple ENR file where the Frequency and ENR values have been entered manually into the Noise Figure Analyzer:

```
# ENR Data File
# Created by N8973A Agilent NFA Series Noise Figure
Analyzer
# Serial Number US00000012 Firmware Revision A.00.01
# 13:37:07 Mar 28, 2000
# Format is: Frequency (Hz), ENR (dB)

[Filetype ENR]
[Version 1.0]
10000000, 15.3500
100000000, 15.4230
1000000000, 15.2280
2000000000, 15.0900
3000000000, 14.9600
4000000000, 14.8400
5000000000, 14.7890
6000000000, 14.7500
7000000000, 14.7720
8000000000, 14.8570
9000000000, 14.9580
10000000000, 15.0600
11000000000, 15.0830
12000000000, 15.1950
13000000000, 15.2710
14000000000, 15.3430
15000000000, 15.4800
16000000000, 15.6750
17000000000, 15.8400
18000000000, 15.8940
```

ENR File Format

Examples

Example 2

The second example is a typical ENR file supplied on diskette with a Noise Source:

```
[Filetype ENR]
[Version 1.0]
[Serialnumber 3318A15364]
[Model 346B]
[Caldate 20000110.13:53:54]
[Temperature 24C]
[Humidity 40%]
!   Frequency   ENR  Unc   Refl. Coef. On   Refl. Coef. Off
!   MHz         dB   dB    Mag   Phase Deg   Mag   Phase Deg
      10 MHz    15.281 .193   .0450  -136.0   .0330   -66.0
      100 MHz   15.291 .190   .0358  +168.0   .0110   -24.6
     1000 MHz   15.118 .151   .0398  +39.6    .0107  +164.5
     2000 MHz   14.999 .168   .0377  -85.7    .0266    +.9
     3000 MHz   14.879 .172   .0267  +150.6   .0390  -129.2
     4000 MHz   14.795 .173   .0130  -18.1    .0313  +106.0
     5000 MHz   14.818 .179   .0359  +169.5   .0104   -99.3
     6000 MHz   14.846 .181   .0556  +63.7    .0451  +104.3
     7000 MHz   14.895 .180   .0430  -37.0    .0579   -2.3
     8000 MHz   15.016 .198   .0232  -160.3   .0491  -123.8
     9000 MHz   15.134 .201   .0122  +71.4    .0407  +107.3
    10000 MHz   15.253 .194   .0080  +116.2   .0248   -15.4
    11000 MHz   15.249 .243   .0241  +65.7    .0259  +144.5
    12000 MHz   15.349 .240   .0196  +8.8     .0457  +32.2
    13000 MHz   15.383 .188   .0217  -5.4     .0362  -61.9
    14000 MHz   15.355 .178   .0228  -66.6    .0075  +151.2
    15000 MHz   15.367 .187   .0141  +141.6   .0136   -13.2
    16000 MHz   15.421 .182   .0251  +6.4     .0030  -127.2
    17000 MHz   15.418 .174   .0242  -100.5   .0148   -29.7
    18000 MHz   15.464 .179   .0183  +124.4   .0198  -149.1
```

A **Caring for Connectors**

The material contained in this appendix may not be apply to the connector you are using on the instrument.

Introduction

Recent advances in measurement capabilities have made connectors and connection techniques more important than ever before. Damage to the connectors on calibration and verification devices, test ports, cables, and other devices represent an increasing burden in downtime and expense.

This Appendix will help you get the best performance from all coaxial microwave connectors:

- To know what to look for when cleaning and inspecting them, in order to preserve their precision and extend their life.
- To make the best possible microwave connections, improving the accuracy and repeatability of all of your measurements, saving both time and money.

Connector Part Numbers

Refer to the latest edition of the HP RF & Microwave Test Accessories Catalog for connector part numbers.

Handling and Storage

Microwave connectors must be handled carefully, inspected before use and when not in use, stored in a way that gives them maximum protection. Avoid touching the connector mating plane surfaces and avoid setting the connectors contact-end down, especially on a hard surface.

Never store connectors with the contact end exposed. Plastic end caps are provided with all Agilent connectors and these should be retained after unpacking and placed over the ends of the connectors whenever they are not in use. Extend the threads of connectors that have a retractable sleeve or sliding connector nut, then put the plastic end cap over the end of the connector.

Above all, never store any devices loose in a box or in a desk or a bench drawer. Careless handling of this kind is the most common cause of connector damage during storage.

Visual Inspection

Visual inspection and, if necessary, cleaning should be done every time a connection is made.

Metal and metal by-product particles from the connector threads often find their way onto the mating plane surfaces when a connection is disconnected and even one connection made with a dirty or damaged connector can damage both connectors beyond repair.

Magnification is helpful when inspecting connectors, but it is not required and may actually be misleading. Defects and damage that cannot be seen without magnification generally have no effect on electrical or mechanical performance. Magnification is of great use in analyzing the nature and cause of damage and in cleaning connectors, but it is not required for inspection.

Obvious Defects and Damage

Examine the connectors first for obvious defects or damage: badly worn plating, deformed threads or bent, broken, or misaligned center conductors. Connector nuts should move smoothly and be free of burrs, loose metal particles, and rough spots.

Immediately discard, or mark for identification and send away for repair, any connector that has obvious defects like these.

Mating Plane Surfaces

Flat contact between the connectors at all points on their mating plane surfaces is required for a good connection. Therefore, particular attention should be paid to deep scratches or dents, and to dirt and metal or metal by-product particles on the connector mating plane surfaces.

Also look for bent or rounded edges on the mating plane surfaces of the center and outer conductors and for any signs of damage due to excessive or uneven wear or misalignment.

Caring for Connectors

Visual Inspection

Light burnishing of the mating plane surfaces is normal, and is evident as light scratches or shallow circular marks distributed more or less uniformly over the mating plane surface. Other small defects and cosmetic imperfections are also normal. None of these affect electrical or mechanical performance.

If a connector shows deep scratches or dents, particles clinging to the mating plane surfaces, or uneven wear, clean it and inspect it again. Damage or defects like dents or scratches, which are deep enough to displace metal on the mating plane surface of the connector, may indicate that the connector itself is damaged and should not be used. Try to determine the cause of the damage before making further connections.

Precision 7 mm Connectors

Precision 7mm connectors, among them APC-7[®] connectors, should be inspected visually with the center conductor collets in place, and whenever the collet has been removed. See Figure A-1.

The collet itself should be inspected for edge or surface damage and for any signs that the spring contacts are bent or twisted. If they are, replace the collet. When the collet has been re-inserted, verify that it springs back immediately when pressed with a blunt plastic rod or with the rounded plastic handle of the collet removing tool. Never use a pencil or your finger for this purpose.

Figure A-1

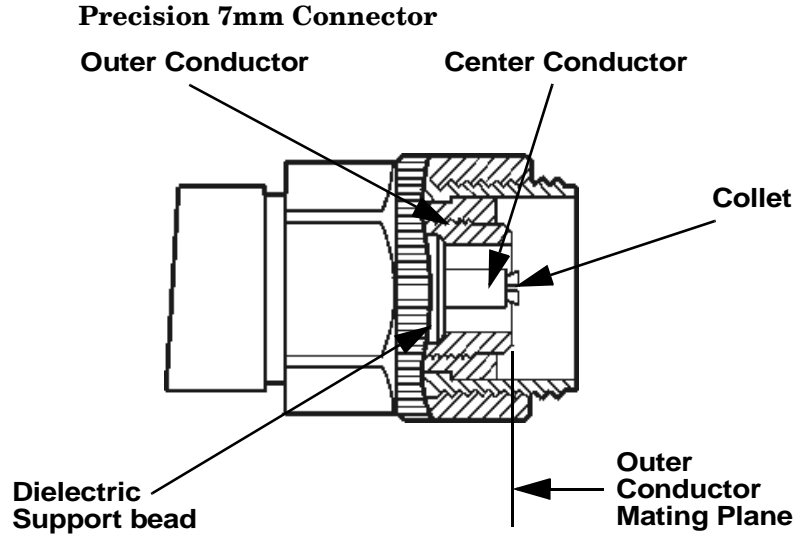

Sexed Connectors

On sexed connectors, especially precision 3.5mm and SMA connectors, pay special attention to the female center conductor contact fingers (Figure A-2 and Figure A-3). These are very easily bent or broken, and damage to them is not always easy to see. Any connector with damaged contact fingers will not make good electrical contact and must be replaced.

Figure A-2

Precision 3.5mm connectors

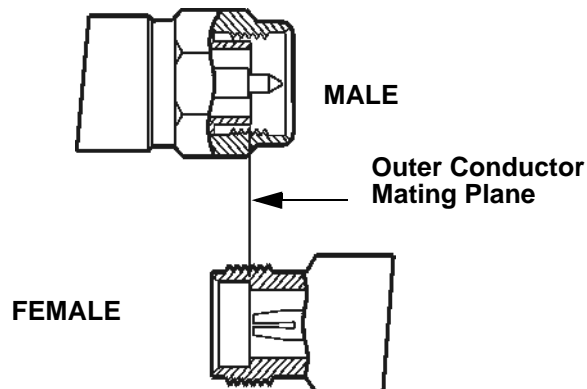

Caring for Connectors
Visual Inspection

Figure A-3

SMA connectors

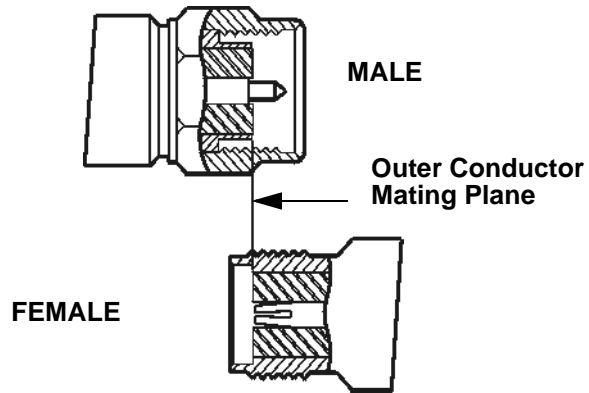

Cleaning

Careful cleaning of all connectors is essential to assure long, reliable connector life, to prevent accidental damage to connectors, and to obtain maximum measurement accuracy and repeatability. Yet it is the one step most often neglected or done improperly. Supplies recommended for cleaning microwave connectors are as follows:

- Compressed Air.
- Alcohol.
- Cotton Swabs.
- Lint-Free Cleaning Cloth.

Compressed Air

Loose particles on the connector mating plane surfaces can usually be removed with a quick blast of compressed air. This is very easy to do and should always be tried first using compressed air from a small pressurized can. The stream of air can be directed exactly where it is wanted through a plastic (not metal) nozzle. No hoses or other connections are needed. Hold the can upright, to avoid spraying liquid along with the vapor.

Cleaning Alcohol

Dirt and stubborn contaminants that cannot be removed with compressed air can often be removed with a cotton swab or lint free cleaning cloth moistened with alcohol.

NOTE

Use the least amount of alcohol possible, and avoid wetting any plastic parts in the connectors with the alcohol.

Caring for Connectors

Cleaning

Alcohol should be used in liquid rather than spray form. If a spray must be used, always spray the alcohol onto a cloth or swab, never directly into a connector.

Very dirty connectors can be cleaned with pure alcohol. Other solutions that contain additives should not be used.

Carefully avoid wetting the plastic support bead (which is easily damaged by alcohol) inside the connector and blow the connector dry immediately with a gentle stream of compressed air.

Precision 7 mm Connectors

When precision 7mm connectors have been cleaned with the center conductor collet removed, insert the collet and clean the mating plane surfaces again.

When the connector is attached to a small component, or to a cable, calibration, or verification standard, the easiest way to do this is to put a lint-free cleaning cloth flat on a table and put a couple of drops of alcohol in the center of the cloth. It should be noted that it is not necessary to remove the collet to use this cleaning method.

Retract the connector sleeve threads so that the connector interface is exposed. Gently press the contact end of the connector into the cloth moistened with alcohol, then turn the connector.

Dirt on the connector interface will be scrubbed away by the cloth without damaging the connector. Blow the connector dry with a gentle stream of compressed air.

This cleaning method can be adapted even for fixed connectors such as those attached to test ports. Simply fold the cloth into several layers of thickness, moisten it, press it against the connector interface, and turn it to clean the connector. Blow the connector dry with a gentle stream of compressed air.

Cleaning Interior Surfaces

Interior surfaces, especially on precision 3.5mm connectors, are very difficult to reach, and it is easy to damage connectors in trying to clean them. The openings are very small, and generally the center conductor is supported only at the inner end, by a plastic dielectric support bead. This makes it very easy to bend or break the center conductor.

One suitable method (Figure A-4) is to cut off the sharp tip of a round wooden toothpick, or a smaller diameter wooden rod, and then to wrap it with a single layer of lint-free cleaning cloth.

Figure A-4

Cleaning interior surfaces



NOTE

Metal must never be used (it will scratch the plated surfaces), and in cleaning precision 3.5mm connectors the diameter must not exceed 0.070 in. (1.7 mm). The wooden handle of a cotton swab, for example, is too large for this purpose. Even though the handle can sometimes be inserted into the connector, even when wrapped in lint-free cloth, movement of the handle against the center conductor can exert enough force on the center conductor to damage it severely.

Caring for Connectors

Cleaning

Moisten the cloth with a small amount of alcohol and carefully insert it into the connector to clean the interior surfaces. Use an illuminated magnifying glass or microscope to see clearly the areas you wish to clean.

Drying Connectors

When you have cleaned a connector, always be sure that it is completely dry before reassembling or using it. Blow the connector dry with a gentle stream of clean compressed air and inspect it again under a magnifying glass to be sure that no particles or alcohol residues remain.

Mechanical Inspection: Connector Gages

Even a perfectly clean, unused connector can cause problems if it is mechanically out of specification. Since the critical tolerances in microwave connectors are on the order of a few ten-thousandths of an inch, using a connector gage is essential.

Before using any connector for the first time, inspect it mechanically using a connector gage. How often connectors should be gaged after that depends upon usage.

In general, connectors should be gaged whenever visual inspection or electrical performance suggests that the connector interface may be out of specification, for example due to wear or damage. Connectors on calibration and verification devices should also be gaged whenever they have been used by someone else or on another system or piece of equipment.

Precision 3.5mm and SMA connectors should be gaged relatively more often than other connectors, owing to the ease with which the center pins can be pulled out of specification during disconnection.

Connectors should also be gaged as a matter of routine - after every 100 connections and disconnections initially, more or less often after that as experience suggests.

Table A-1 Recommended connector gages

Connector gage kits containing all of the items required are included in many Agilent calibration kits. They are also available separately. Part numbers are as follows.	
Type	Part Number/Ordering Information
Precision 7mm (APC-7)	85050-80012
Precision 3.5mm	11752D
Precision 2.4mm	11752E
Type-N	85054-60047

Mechanical Specifications

The critical dimension to be measured, regardless of connector type, is the position (generally, the recession or setback) of the center conductor relative to the outer conductor mating plane.

Mechanical specifications for connectors specify a maximum distance and a minimum distance that the center conductor can be positioned behind (or, in female Type-N connectors, in front of) the outer conductor mating plane. Nominal specifications for each connector type exist, but the allowable tolerances (and sometimes the dimensions themselves) differ from manufacturer to manufacturer and from device to device. Therefore, before gaging any connector, consult the mechanical specifications provided with the connector or the device itself.

Precision 7mm Connectors

In precision 7mm connectors, contact between the center conductors is made by spring-loaded contacts called collets. These protrude slightly in front of the outer conductor mating plane when the connectors are apart. When the connection is tightened, the collets are compressed into the same plane as the outer conductors.

For this reason, two mechanical specifications are generally given for precision 7mm connectors: the maximum recession of the center conductor behind the outer conductor mating plane with the center conductor collet removed; and a minimum and maximum allowable protrusion of the center conductor collet in front of the outer conductor mating plane with the collet in place.

The center conductor collet should also spring back immediately when pressed with a blunt plastic rod or with the rounded plastic handle of the collet removing tool. Never use a pencil or your finger for this purpose.

With the center conductor collet removed, no protrusion of the center conductor in front of the outer conductor mating plane is allowable, and sometimes a minimum recession is required. Consult the mechanical specifications provided with the connector or the device itself.

Sexed Connectors

In Type-N and precision 3.5mm connectors, the position of the center conductor in the male connector is defined as the position of the shoulder of the male contact pin - not the position of the tip. The male contact pin slides into the female contact fingers and electrical contact is made by the inside surfaces of the tip of the female contact fingers on the sides of the male contact pin.

50 Ohm Type-N Connectors

NOTE

No Type-N connector should ever be used when there is any possibility of interference between the shoulder of the male contact pin and the tip of the female contact fingers when the connectors are mated. In practice this means that no Type-N connector pair should be mated when the separation between the tip of the female contact fingers and the shoulder of the male contact pin could be less than zero when the connectors are mated. Gage Type-N connectors carefully to avoid damage.

Type-N connectors differ from other connector types in that the outer conductor mating plane is offset from the mating plane of the center conductors. The outer conductor sleeve in the male connector extends in front of the shoulder of the male contact pin. When the connection is made, this outer conductor sleeve fits into a recess in the female outer conductor behind the tip of the female contact fingers (Figure A-5).

Figure A-5

Type-N connectors

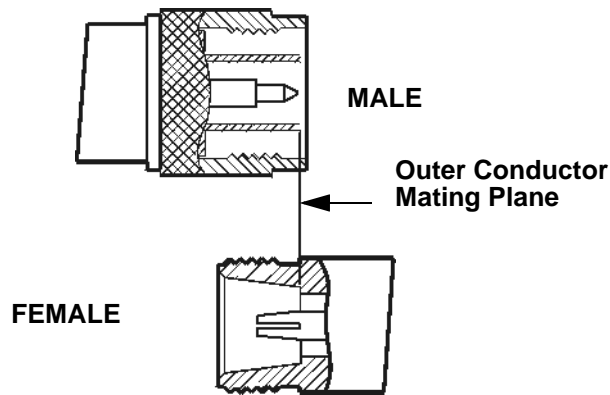

Therefore the mechanical specifications of Type-N connectors give a maximum protrusion of the female contact fingers in front of the outer conductor mating plane and a minimum recession of the shoulder of the male contact pin behind the outer conductor mating plane.

As Type-N connectors wear, the protrusion of the female contact fingers generally increases, due to wear of the outer conductor mating plane inside the female connector. This decreases the total center conductor contact separation and should be monitored carefully.

75 Ohm Type-N Connectors

75 Ω Type-N connectors differ from 50 Ω Type-N connectors most significantly in that the center conductor, male contact pin, and female contact hole are smaller. Therefore, mating a male 50 Ω Type-N connector with a female 75 Ω Type-N connector will destroy the female 75 Ω connector by spreading the female contact fingers apart permanently or even breaking them.

NOTE

If both 75 Ω and 50 Ω Type-N connectors are among those on the devices you are using, identify the 75 Ω Type-N connectors to be sure that they are never mated with any 50 Ω Type-N connectors.

Using Connector Gages

Before a connector gage is used, it must be inspected, cleaned, and zeroed.

Inspecting and Cleaning the Gage

Inspect the connector gage and the gage calibration block carefully, exactly as you have inspected the connector itself. Clean or replace the gage or the block if necessary (dirt on the gage or block will make the gage measurements of the connectors inaccurate and can transfer dirt to the connectors themselves, damaging them during gaging or when the connection is made).

Zeroing the Gage

Zero the gage by following the steps described below. Be sure that you are using the correct connector gage and correct end of the gage calibration block for the connector being measured.

- Hold the gage by the plunger barrel (not the dial housing or cap) and, for male connectors, slip the protruding end of the calibration block into the circular bushing on the connector gage. For precision 7mm, female precision 3.5mm use the flat end of the gage calibration block. For female Type-N connectors, use the recessed end of calibration block.
- Hold the gage by the plunger barrel only (Figure A-6). Doing so will prevent errors in gage readings due to the application of stresses to the gage plunger mechanism through the dial indicator housing.
- Carefully bring the gage and gage block together, applying only enough pressure to the gage and gage block to result in the dial indicator pointer settling at a reading.

Caring for Connectors
Using Connector Gages

- Gently rock the two surfaces together, to make sure that they have come together flatly. The gage pointer should now line up exactly with the zero mark on the gage. If it does not, inspect and clean the gage and gage calibration block again and repeat this process. If the gage pointer still does not line up with the zero mark on the gage, loosen the dial lock screw and turn the graduated dial until the gage pointer exactly lines up with zero. Then retighten the lock screw.

Figure A-6 **Using the connector gage**



NOTE

Gages should be checked often, to make sure that the zero setting has not changed. Generally, when the gage pointer on a gage that has been zeroed recently does not line up exactly with the zero mark, the gage or calibration block needs cleaning. Clean carefully and check the zero setting again.

Measuring Connectors

Measuring the recession of the center conductor behind the outer conductor mating plane in a connector is done in exactly the same way as zeroing the gage, except of course that the graduated dial is not re-set when the measurement is made.

If the connector has a retractable sleeve or sliding connector nut - precision 7mm connectors, for example - extend the sleeve or nut fully. This makes it easier to keep the gage centered in the connector.

Hold the gage by the plunger barrel and slip the gage into the connector so that the gage plunger rests against the center conductor. Carefully bring the gage into firm contact with the outer conductor mating plane.

Apply only enough pressure to the gage so that the gage pointer settles at a reading.

Gently rock the connector gage within the connector, to make sure that the gage and the outer conductor have come together flatly. Read the recession (or protrusion) from the gage dial. (For maximum accuracy, measure the connector several times and take an average of the readings.)

Rotate the gage relative to the connector between each measurement. To monitor connector wear, record the readings for each connector over time.

Making Connections

Making good connections is easy if a few simple principles are kept in mind:

- All connectors must be undamaged, clean, and within mechanical specification.
- The connectors must be precisely aligned with one another and in flat physical contact at all points on the mating plane surfaces.
- The connection must not be too tight or too loose.
- Lateral or horizontal (bending) force must not be applied to the connection, nor should any connection ever be twisted.

Align Connectors Carefully

Careful alignment of the connectors is critical in making a good connection, both to avoid damaging connectors and devices and to assure accurate measurements.

As you bring one connector up to the other and as you make the actual connection, be alert for any sign that the two connectors are not aligned perfectly. If you suspect that misalignment has occurred, stop and begin again.

Alignment is especially important in the case of sexed connectors, such as precision 3.5mm and SMA connectors, to avoid bending or breaking the contact pins. The center pin on the male connector must slip concentrically into the contact fingers of the female connector. This requires great care in aligning the two connectors before and as they are mated.

When they have been aligned, the center conductors must be pushed straight together, not twisted or screwed together, and only the connector nut (not the device itself) should then be rotated to make the connection. (slight resistance is generally felt as the center conductors mate).

Alignment of precision 7mm connectors is made easier by the fact that the connector sleeve on one of the connectors must be extended fully (and the sleeve on the other connector retracted fully) in order to make the connection. Extending the sleeve creates a cylinder into which the other connector fits.

If one of the connectors is fixed, as on a test port, extend that connector sleeve and spin its knurled connector nut to make sure that the threads are fully extended, while on the other connector, fully retract the connector sleeve.

To Make a Preliminary Connection

Align the two connectors carefully and engage the connector nut over the exposed connector sleeve threads on the other connector.

Gently turn the connector nut until a preliminary connection is made. Let the connector nut pull the two connectors straight together. Do not twist one connector body into the other (as you might drive a screw or insert a light bulb) as this is extremely harmful and can damage the connectors.

When the mating plane surfaces make uniform, light contact, the preliminary connection is tight enough. Do not overtighten this connection.

NOTE

At this stage all you want is a connection in which the outer conductors make gentle contact at all points on both mating surfaces. Very light finger pressure (no more than 2 inch-ounces of torque) is enough.

Final Connection Using a Torque Wrench

When the preliminary connection has been made, use a torque wrench to make the final connection. Tighten the connection only until the “break” point of the wrench is reached, when the wrench handle gives way at its internal pivot point. Do not tighten the connection further.

Also make sure that torque actually is being applied to the connection through the torque wrench, not only to the wrench handle or in any way that prevents the break point of the wrench from controlling the torque applied to the connection. Suggestions to ensure that torque is actually being applied are given in Table A-2 on page 71.

Using a torque wrench guarantees that the connection will not be too tight, thus preventing possible damage to the connectors and impaired electrical performance. It also guarantees that all connections will be made with the same degree of tightness every time they are made.

Torque wrenches pre-set to the correct value for each connector type are included in many Agilent calibration kits, and they are also available separately. Torque settings are detailed in Table A-2.

When using a torque wrench, prevent rotation of anything other than the connector nut that is being tightened with the torque wrench. Generally this is easy to do by hand (all the more so if one of the connectors is fixed) as on a test port. In other situations, an open-end wrench can be used to keep the bodies of the connectors from turning.

Hold the torque wrench lightly by the knurled end of the handle only. Apply force at the end of the torque wrench only, perpendicular to the wrench and always in a plane parallel to the outer conductor mating planes. This will result in torque being applied to the connection through the wrench until the break point of the wrench is reached.

Avoid pivoting the wrench handle on the thumb or other fingers. This results in an unknown amount of torque being applied to the connection when the break point of the wrench is reached. Avoid twisting the head of the wrench relative to the outer conductor mating plane. This results in applying more than the recommended torque.

Table A-2 Recommended Torque Settings

Type	Description
Precision 7mm	12 lb-in (136 N-cm.)
Precision 3.5mm	8 lb-in (90 N-cm)
SMA	5 lb-in (56 N-cm) Use the SMA wrench to connect male SMA connectors to female precision 3.5mm connectors. Connections of male precision 3.5mm. connectors to female SMA connectors can be made with the precision 3.5mm torque wrench (8 lb-in).
Type-N	Type-N connectors may be connected finger tight. If a torque wrench is used, 12 lb-in (136 N-cm) is recommended.

To reiterate the main do's and do not's detailed previously:

- Avoid holding the wrench tightly, in such a way that the handle is not pivoted but simply pushed downward the same amount throughout its length. If this is done, an unlimited amount of torque can be applied.
- Hold the wrench at the same point near the end of the handle every time, and always in the same orientation. Whenever possible, begin tightening the connection with the wrench held horizontally

Disconnection

Disconnect connectors by first loosening the connector nut that was tightened in order to make the connection. If necessary, use the torque wrench or an open-end wrench to start the process, but leave the connection finger tight. At all times support the devices and the connection to avoid putting lateral (bending) force on the connectors.

Complete the disconnection by disconnecting the connector nut completely.

Caring for Connectors
Making Connections

NOTE

Never disconnect connectors by twisting one connector or device out of the other as one might remove a screw or a light bulb. This is extremely harmful and connector damage can occur whenever the device body rather than the nut alone is being turned.

If the connection is between sexed connectors, pull the connectors straight apart and be especially careful not to twist the body of any device as you do so. Twisting the connection can damage the connector by damaging the center conductors or the interior component parts to which the connectors themselves are attached. It can also scrape the plating from the male contact pin or even (in rare instances) unscrew the male or female contact pin slightly from its interior mounting, bringing it out of specification (this can also occur if the female contact fingers are unusually tight).

Adapters

Adapters are used to connect a device with one connector interface to a device or to test equipment that has another interface, or to reduce wear on connectors that may be difficult or expensive to replace. Reducing wear is possibly the most important use of adapters, especially when devices that have SMA connectors are being used.

SMA connectors are low-cost connectors generally used up to about 23GHz. They are not precision mechanical devices and are not designed for repeated connections and disconnections as they wear out quickly and are very often found, upon assembly, to be out of specification, even before they have been used. This makes them potentially destructive to any precision 3.5mm connectors with which they might be mated.

CAUTION

Worn, damaged, or out-of-specification SMA connectors can destroy a precision 3.5mm connector even on the very first connection. For this reason it is recommended that you use high-quality precision adapters, sometimes called “connector savers”, whenever more than a few connections are to be made between SMA and precision 3.5mm connectors.

In most applications two adapters will be required, one each at the input and the output of the device. Male-female adapters cause no change in the sex of the interface. The same interface is presented when the adapter is in place as is presented in the original setup.

Same-sex adapters (male-male, female-female) change the sex of the interface. For example, if the original interface presents a male connector, attaching a female-female adapter will result in a female interface to which devices or cables that have male SMA (or male precision 3.5mm) connectors can be connected.

Adapters are included in many Agilent calibration kits and with many Agilent devices, or they may be ordered separately.

Caring for Connectors
Adapters

Table A-3 Adapters

Type	Description
Precision 7mm and Type-N	Precision 7mm/male 3.5mm Precision 7mm/female 3.5 mm Precision 7mm/male 50Ω Type-N Precision 7mm/female 50Ω Type-N
Precision 3.5mm and SMA	Male 3.5mm/female 3.5mm Male 3.5mm/female 3.5 mm Female 3.5mm/female 3.5mm Precision 7mm/male 3.5mm Precision 7mm/female 3.5mm “Connector saver” male 3.5mm/female 3.5 mm “Connector saver” male 3.5mm/male 3.5mm

Principles of Microwave Connector Care

Table A-4 Principles of Microwave Connector Care

Handling and Storage	
DO	DO NOT
<ul style="list-style-type: none"> • Keep connectors clean. • Extend sleeve or connector nut. • Use plastic end caps during storage. 	<ul style="list-style-type: none"> • Touch mating plane surfaces. • Set connectors contact-end down.
Visual Inspection	
DO	DO NOT
<ul style="list-style-type: none"> • Inspect each connector carefully before every connection. • Look for metal particles, scratches and dents. 	<ul style="list-style-type: none"> • Use a damaged connector - EVER.
Cleaning	
DO	DO NOT
<ul style="list-style-type: none"> • Try compressed air first. • Clean connector threads. 	<ul style="list-style-type: none"> • Use any abrasives. • Get liquid onto plastic support beads.

Caring for Connectors
Principles of Microwave Connector Care

Table A-4 Principles of Microwave Connector Care

Gaging	
DO	DO NOT
<ul style="list-style-type: none"> • Clean and zero the gage before using. • Use correct gage type. • Use correct end of calibration block. • Gage all connectors before first use. 	<ul style="list-style-type: none"> • Use an out-of-spec connector.
Making Connections	
DO	DO NOT
<ul style="list-style-type: none"> • Align connectors carefully. • Make preliminary connection lightly. • Turn connector nut only to tighten. • Use a torque wrench for final connection. 	<ul style="list-style-type: none"> • Apply bending force to connection. • Overtighten preliminary connection. • Twist or screw in connectors. • Tighten past “break” point of torque wrench.

This information is subject to change without notice.
 © Keysight Technologies, 2014
 Published in USA, August 2014
 00346-90148
www.keysight.com