

FieldFox Handheld Analyzers

4/6.5/9, 10/14/18/26.5/32/44/50/54 GHz (B and C Models)

Introduction

This configuration guide describes configurations, options, and accessories for the FieldFox B-Series and new C-Series handheld analyzers. Use this guide, along with the technical overview and data sheet, for a complete description of the analyzers. The table on page 3 titled “FieldFox B/C-Series Family and Options” shows a comparison of the functions available in the FieldFox B- and C-Series family of analyzers. The table on page 4 titled “FieldFox N9912C and Options” details the unique configurations available for the N9912C FieldFox RF analyzer that offer greater flexibility,

Note: Combination analyzer (combo) = Cable and Antenna Tester (CAT) + Vector Network Analyzer (VNA) + Signal Analyzer (SA).

Included Accessories

The following accessories are included with every FieldFox:

- AC/DC adapter
- Battery
- Soft carrying case



Table of Contents

FieldFox B/C-Series Family and Options	3
FieldFox N9912C and Options.....	4
FieldFox RF and Microwave (Combination) Analyzers	5
FieldFox RF and Microwave (Combination) Analyzer FAQs.....	7
FAQs – Applicable to All FieldFox RF and Microwave Analyzers	11
FieldFox RF and Microwave Signal Analyzers.....	12
FieldFox Signal Analyzer FAQs	14
Upgrades	14
Documentation.....	18
Calibration Kits.....	18
Accessories.....	20

FieldFox B/C-Series Family and Options

Option	Description	Combination Analyzers	Signal Analyzers
		N9913/4/5/6/7/8B, N9913/4/5C, N9950/1/2/3B	N9933/4/5/6/7/8B, N9933/4/5C, N9960/1/2/3B
CAT / Vector Network Analysis			
010	VNA time domain	✓	—
210	VNA transmission/reflection	✓	—
211	VNA full 2-port S-parameters	✓	—
212	1-port mixed-mode S-parameters	✓	—
215	TDR cable measurements	✓	—
	Cable and antenna analyzer	Base model ¹	— ²
308	Vector voltmeter	✓	—
320	Reflection meas. (RL, VSWR and scalar meas.)	— ³	✓, not available on C model
Spectrum Analysis			
209	Extended Range Transmission Analysis (ERTA)	✓	✓
220	Tracking generator	✓ ⁴	✓
233	Spectrum analyzer	✓	Base model ¹
235	Pre-amplifier	✓	✓
236	Interference analyzer and spectrogram	✓	✓
238	Spectrum analyzer time gating	✓	✓
312	Channel scanner	✓	✓
350	Real-Time Spectrum Analyzer (RTSA)	✓	✓
351	I/Q Analyzer (IQA)	✓	✓
352	Indoor and outdoor mapping	✓	✓
353	IQ streaming	✓	✓
355	Analog demodulation	✓	✓
356	Noise Figure (NF)	✓	✓
357	Pulse generator	✓	✓
358	EMF measurements	✓	✓
360	Phased array antenna support	✓	✓
361	EMI measurements	✓	✓
366	Interference finder (manual mode)	✓	✓
370/371	Over-the-Air (OTA) LTE FDD/TDD	✓	✓
378	Over-the-Air (OTA) 5G NR	✓	✓
390	Directional finding – TDOA node support	✓	✓
B04	Analysis bandwidth, 40 MHz ⁵	✓	✓
B10	Analysis bandwidth, 120 MHz ⁵	✓	✓
Power Measurements			
208	USB power sensor meas. versus frequency	✓	✓
302	USB power sensor support	✓	✓
310	Built-in power meter	✓	✓
330	Pulse meas. with USB peak power sensor	✓	✓
System Features			
030	Remote control capability	✓	✓
307	GPS receiver	✓	✓
309	DC bias variable-voltage source	✓	✓
—	Frequency extender support ⁶	✓	✓
Windows Based Software			
89601C	PathWave VSA (89600 VSA) software	✓	✓
N6820ES	Surveyor 4D software	✓	✓
SJ002A	WaveJudge Wireless Analyzer Toolset	✓	✓
S9910A	Keysight Spectrum Management (KSMS)	✓	✓
S9911A	Directional Finding - TDOA	✓	✓

1. Base model functionality listed is the primary function of that instrument. For example, on the N991xB,C/5xB combo analyzers, cable and antenna analyzer is the standard function included with every N991xB,C/5xB.
2. Cable and antenna analyzer is not available on the N993xB,C/6xB. A subset of measurements, return loss and VSWR, is available as Option 320.
3. Option 320 is not applicable to N991xB,C/5xB. The N991xB,C/5xB includes reflection measurements of return loss and VSWR as standard functions.
4. On the N991xB,C/5xB analyzers, order Options 233 and 210 to obtain a tracking generator with the spectrum analyzer. There is no Option 220 on the N991xB,C/5xB analyzers. Option 233 provides the spectrum analyzer capability and Option 210 the "tracking" capability.
5. 10 MHz standard.
6. Models N9913/33B,C, N9914/34B,C and N9915/35B,C do not support frequency extenders. This is because the mixers' starting LO frequency is higher than 10 GHz and the FieldFox Port 1 provides the LO to the mixer. For a list of supported VDI frequency extenders, see Accessories pages 19-20.

FieldFox N9912C and Options

Base Unit	FieldFox RF Analyzer	
Instrument Functions (Must Pick One from CA, NA and SA, Only Can Pick One from Each Group CA, NA and SA)		
CA4	Cable and antenna analyzer 4 GHz	
CA6	Cable and antenna analyzer 6.5 GHz	Frequency can be upgraded via N9912CU
CAX	Cable and antenna analyzer 10 GHz	Frequency can be upgraded via N9912CU
NA4	Vector network analyzer 4 GHz	Full 2 port VNA
NA6	Vector network analyzer 6.5 GHz	Frequency can be upgraded via N9912CU
NAX	Vector network analyzer 10 GHz	Frequency can be upgraded via N9912CU
SA4	Spectrum analyzer 4 GHz	
SA6	Spectrum analyzer 6.5 GHz	Frequency can be upgraded via N9912CU
SAX	Spectrum analyzer 10 GHz	Frequency can be upgraded via N9912CU
Measurement Options		
010	VNA time domain	Requires network analyzer (NA)
i030	Remote control capability	Requires an iOS or an Android device
208	USB power sensor meas. versus frequency	Require option 302
215	TDR cable measurements	Requires an CA option
220	Tracking generator	Requires spectrum analyzer unless VNA option is ordered; Required for the independent source function in SA mode
235	Pre-amplifier	Require spectrum analyzer
236	Interference analyzer and spectrogram	Require spectrum analyzer
238	Spectrum analyzer time gating	Require spectrum analyzer
302	USB power sensor support	Need to order USB power sensor. See FAQ A
307	GPS receiver	Need to order GPS antenna, N9910X-825. See FAQ C
308	Vector voltmeter	Require VNA option
309	DC bias variable-voltage source	Recommend N9910X-713 cable. See FAQ D
310	Built-in power meter	No power meter required
312	Channel scanner	Require spectrum analyzer. Require the corresponding option to support a specific app. For example, to support EMF in channel scanner requires 358; to support indoor and outdoor mapping requires 352
330	Pulse meas. with USB peak power sensor	Require option 302
350	Real-Time Spectrum Analyzer (RTSA)	Require spectrum analyzer
352	Indoor and outdoor mapping	Require channel scanner at one from option 312, 370, 371, 378 and GPS option 307
355	Analog demodulation	Require spectrum analyzer
358	EMF measurements	Require spectrum analyzer and 85572A Tri-axial antenna
361	EMI measurements	Require Spectrum analyzer
366	Interference finder (manual mode)	Require Spectrum analyzer, GPS option 307, and 85574A Handheld direction antenna
370	Over-the-Air (OTA) LTE FDD	Require Spectrum analyzer and GPS option 307
371	Over-the-Air (OTA) LTE TDD	Require Spectrum analyzer and GPS option 307
378	Over-the-Air (OTA) 5G NR	Require Spectrum analyzer and GPS option 307
B04	Analysis bandwidth, 40 MHz	Require Spectrum analyzer
Windows PC Software		
89601C	PathWave VSA (89600 VSA) software	Require spectrum analyzer
SJ002A	WaveJudge Wireless Analyzer Toolset	Require spectrum analyzer
S9910A	Keysight Spectrum Management (KSMS)	Require spectrum analyzer

FieldFox RF and Microwave (Combination) Analyzers

Analyzer Models

Step 1. Select the model that provides the desired frequency range

Model	Description	CAT and VNA Frequency	SA Frequency ¹	Test Port Connectors
N9913B	4 GHz FieldFox RF analyzer	30 kHz to 4 GHz	9 kHz to 4 GHz	Type-N (f)
N9914B	6.5 GHz FieldFox RF analyzer	30 kHz to 6.5 GHz	9 kHz to 6.5 GHz	Type-N (f)
N9915B	9 GHz FieldFox microwave analyzer	30 kHz to 9 GHz	9 kHz to 9 GHz	Type-N (f)
N9916B	14 GHz FieldFox microwave analyzer	30 kHz to 14 GHz	9 kHz to 14 GHz	Type-N (f)
N9917B	18 GHz FieldFox microwave analyzer	30 kHz to 18 GHz	9 kHz to 18 GHz	Type-N (f)
N9918B	26.5 GHz FieldFox microwave analyzer	30 kHz to 26.5 GHz	9 kHz to 26.5 GHz	3.5 mm (m)
N9950B	32 GHz FieldFox microwave analyzer	300 kHz to 32 GHz	9 kHz to 32 GHz	2.4 mm (m)
N9951B	44 GHz FieldFox microwave analyzer	300 kHz to 44 GHz	9 kHz to 44 GHz	2.4 mm (m)
N9952B	50 GHz FieldFox microwave analyzer	300 kHz to 50 GHz	9 kHz to 50 GHz	2.4 mm (m)
N9953B	54 GHz FieldFox microwave analyzer	300 kHz to 54 GHz	9 kHz to 54 GHz	1.8 mm (m)
N9913C	4 GHz FieldFox RF analyzer	3 kHz to 4 GHz	3 kHz to 4 GHz	Type-N (f)
N9914C	6.5 GHz FieldFox RF analyzer	3 kHz to 6.5 GHz	3 kHz to 6.5 GHz	Type-N (f)
N9915C	10 GHz FieldFox RF analyzer	3 kHz to 10 GHz	3 kHz to 10 GHz	Type-N (f)
N9912C	FieldFox RF analyzer	3 kHz to 4/6.5/10 GHz ²	3 kHz to 4/6.5/10 GHz ²	Type-N (f)

Analyzer Options ³

Step 2. Select optional measurement capabilities

Any of these options can easily be added as a software upgrade in the future.

Option	Description	Prerequisite Options/Notes
CAT/Vector Network Analysis		
010	VNA time domain	Requires 210, recommend 211. See FAQ #7
210	VNA transmission/reflection	Recommend ordering a calibration kit. See FAQ #4 and FAQ #6
211	VNA full 2-port S-parameters	Requires 210, recommend ordering a calibration kit. See FAQ #5
212	1-port mixed-mode S-parameters	Requires 210 and 211
215	TDR cable measurements	—
308	Vector voltmeter	210 and 211 required for full VVM functionality. See FAQ #8
Spectrum Analysis		
209	Extended Range Transmission Analysis (ERTA)	Requires 233 and 210 for Combo analyzers (N991x/5x), or 220 for Signal analyzers (N993x/6x). Recommend 307. Requires two FieldFox units. See FAQ #9. See page 10 for typical configuration.
233	Spectrum analyzer	—
235	Pre-amplifier	Requires 233
236	Interference analyzer and spectrogram	Requires 233
238	Spectrum analyzer time gating	Requires 233
312	Channel scanner	Requires 233. Require the corresponding option to support a specific app. For example, to support EMF in channel scanner requires 358; to support indoor and outdoor mapping requires 352
350	Real-Time Spectrum Analyzer (RTSA)	Requires 233, Recommend 235. See FAQ # 11

1. Useable to 5 kHz for N991x/5xB.

2. The maximum frequency of the N9912C is defined by option selected and may be upgradable via license keys. Refer to page 4 for more details.

3. This table is applicable for N991xB/C and N995xB excluding N9912C.

Option	Description	Prerequisite Options/Notes
351	I/Q Analyzer (IQA)	Requires 233
352	Indoor and outdoor mapping	Requires 233, 307, and at least one of 312, 360, 370, 371, 377 or 378. See FAQ #15
353	IQ streaming	Requires 233, 351
355	Analog demodulation	Requires 233
356	Noise Figure (NF)	Requires 233, 235, 309 and accessory item N9910X-713 BNC to SMB cable. See FAQ #13 for external preamplifier and noise source requirements.
357	Pulse generator	Requires 233
358	EMF measurements	Requires 233. Also requires triaxial antenna. See FAQ #16
360	Phased array antenna support	Requires 233. Also requires phased array antenna. N995x/6xB models are required. See FAQ #14
361	EMI measurements	Requires 233
366	Interference finder (manual mode)	Requires 233, 307, and 85574A Handheld direction antenna
370	Over-the-Air (OTA) LTE FDD	Requires 233 and 307. Recommend 235.
371	Over-the-Air (OTA) LTE TDD	Requires 233 and 307. Recommend 235.
377	Over-the-Air (OTA) 5G TF	Requires 233 and 307. Recommend 235. See FAQ #14 N995xB models are required. 5G TF is pre-5G standard. Not available on C models
378	Over-the-Air (OTA) 5G NR	Requires B10 and 307. Recommend 235. For FR2 frequencies above 26.5 GHz, requires N995xB models. See FAQ #18.
390	Directional finding – TDOA node support	Requires 233, 307
B04	Analysis bandwidth, 40 MHz ¹	Requires 233. Recommend 350, 351 or PathWave VSA (formerly 89600 VSA) software
B10	Analysis bandwidth, 120 MHz ¹	Requires 233. Recommend 350, 351, 378 or PathWave VSA (formerly 89600 VSA) software.
Power Measurements		
208	USB power sensor meas. versus frequency	Requires 302 See FAQ I
302	USB power sensor support	Need to order USB power sensor ² See FAQ A
310	Built-in power meter	No power sensor required. See FAQ B
330	Pulse meas. with USB peak power sensor	Requires 302 and USB peak power sensor. See FAQ G and FAQ H
System Features		
030	Remote control capability	Requires an iOS or an Android device
307	GPS receiver	Need to order GPS antenna, N9910X-825. See FAQ C
309	DC bias variable-voltage source	Recommend N9910X-713 cable. See FAQ D
—	Frequency extender support	Requires 233. Optional 350, 351, 360, 370, 371, 377, 378, PathWave VSA (formerly 89600 VSA) software. See Accessories pages
Windows Based Software		
89601C	PathWave VSA (89600 VSA) software	Requires 233
N6820ES	Surveyor 4D software	Requires 233, 235 and 307. See FAQ #17
SJ002A	WaveJudge Wireless Analyzer Toolset	Requires 233
S9910A	Keysight spectrum management software (KSMS)	Requires 233, 235 and 307
S9911A	Directional Finding - TDOA	Requires S9910A

1. 10 MHz standard.

2. List of compatible sensors available from www.keysight.com/find/fieldfoxsupport.

FieldFox RF and Microwave (Combination) Analyzer FAQs¹

Question	Answer
1. What is included with a base N991x/5xB analyzer?	<p>The base model includes the cable and antenna analyzer</p> <p>Measurements: DTF (dB, linear, VSWR), return loss and DTF, return loss (dB), and 1-port cable loss</p> <p>Calibrations: CalReady, OSL, and response calibration</p> <p>Note: 2-port insertion loss is NOT included with the base model, if 2-port insertion loss is needed, order Option 210</p> <p>Note: Base analyzer does not have phase information, for S11 or S21 phase, order Option 210</p>
2. What is included with N991x/5xB Option 233?	<p>Basic spectrum analysis, four traces, different detector types, radio standard selection, limit lines</p> <p>Channel power, occupied bandwidth, adjacent channel power, spectrum emission mask</p> <p>AM/FM tune and listen, field strength measurements, antenna factors, frequency counter marker</p> <p>Tracking generator (TG)/Independent source:</p> <ul style="list-style-type: none"> TG CW mode (source CW frequency can be set independent of SA frequency) - included TG CW coupled mode (source CW frequency is auto coupled to SA's center frequency) - included TG tracking mode (traditional TG operation, swept SA coupled to swept source) - (requires Option 210)
3. What is included with N991x/5xB Option 236?	Interference analyzer and spectrogram, trace playback and recording
4. What is included with N991x/5xB Option 210?	<p>Option 210 adds a VNA with transmission/reflection (T/R) capability</p> <p>Measurements: S21, S11, magnitude and phase</p> <p>Additionally, in the CAT mode, you can measure 2-port insertion loss</p> <p>Calibrations: CalReady, OSL, response, and enhanced response cal</p> <p>If you need all four S-parameters, order Options 210 and 211</p> <p>If you need 2-port cal, order Options 210 and 211</p> <p>Adds tracking mode to the tracking generator/independent source included with Option 233, spectrum analyzer</p>
5. What is included with N991x/5xB Option 211?	<p>Option 211 adds full 2-port S-parameter capability to the VNA mode</p> <p>Measurements: All four S-parameters (S11, S21, S22, S12), magnitude and phase</p> <p>Calibrations: CalReady, OSL, response, enhanced response, and full 2-port calibration</p>
6. Can I measure group delay on N991x/5xB analyzers?	If you have phase measurement capability, then you can measure group delay. Option 210 is required for any phase measurement capability. So, if you do not have Option 210, you cannot measure group delay.
7. What is included with N991x/5xB Option 010?	<p>S11/S21 in time domain, if Option 210 is ordered. To get time domain data for all four S-parameters and full 2-port cal, order Option 211.</p> <p>View both time and frequency domain data at the same time</p> <p>Low-pass, impulse, and band-pass modes</p> <p>Minimum, medium, and maximum window</p> <p>Gating</p>
8. What is included with N991x/5xB Option 308?	<p>With Option 308: 1-port cable trimming</p> <p>With Options 308 and 210: 1-port cable trimming, 2-port transmission</p> <p>With Options 308, 210, and 211: 1-port cable trimming, 2-port transmission, A/B and B/A</p> <p>Note: A/B and B/A measurements require an external source</p>
9. What are the requirements for Option 209?	<p>Extended Range Transmission Analysis (ERTA) or Option 209 is a scalar measurement system based on the use of two (2) FieldFox units. One FieldFox acts as the source and reference receiver, while the second FieldFox acts as the measurement receiver. When different frequency models are used in an ERTA pair, the system frequency range is limited to the lowest of the pair.</p> <p>Required Hardware</p> <p>A. Two (2) FieldFox units. FieldFox units can be any of these models:</p> <ul style="list-style-type: none"> FieldFox combination analyzers: N9913/14/15/16/17/18/50/51/52/53B, N9913/14/15C FieldFox signal analyzers: N9933/34/35/36/37/38/60/61/62/63B, N9933/34/35C <p>The two FieldFox units used in ERTA do not have to be the same model.</p> <p>ERTA requires the following options on Combo FieldFox models (N9913/14/15/16/17/18/50/51/52/53B and C model):</p> <ul style="list-style-type: none"> Option 210, VNA transmission/reflection Option 233, spectrum analyzer <p>ERTA requires the following options on SA FieldFox models (N9933/34/35/36/37/38/60/61/62/63B and C models)</p> <ul style="list-style-type: none"> Option 220, tracking generator

1. Some of FieldFox options may not apply to the N9912C. Refer to the table on page 4 for more details. Additionally, to enable the *independent Source* function in the Spectrum Analyzer (SA) mode on the N9912C with options SA4, SA6, or SAX, option 220 (Tracking Generator) is required.

Question	Answer												
	<p>Both FieldFox units (the one used as the source, and the other used as the receiver) must have the options listed above. The ERTA option (209) cannot be installed unless 210 and 233 are present on a combo analyzer; or 220 is present on a SA analyzer.</p> <p>With either the Combo or SA FieldFox units, the following options are highly recommended:</p> <ul style="list-style-type: none"> Option 235, preamplifier – this option increases the measurement dynamic range by increasing the received signal power Option 307, GPS receiver – this option increases the dynamic range by increasing the frequency accuracy and permitting the use of a narrower RBW <p>B. Power splitter, two-resistor model, Keysight 11667A, 11667B, or 11667C. Other power splitters can be used but the specifications listed are based on the match and tracking performance of 11667A, 11667B, or 11667C. Three-resistor power splitters are not recommended.</p> <p>C. N9910X-712, Trigger/Reference-in cable, SMA (m) to BNC(f), 1 m, quantity two</p> <p>D. N9910X-713, Trigger/Reference-out cable, SMB (m) to BNC (m), 1 m, quantity two</p> <p>E. LAN connection – For ERTA, the two FieldFox units communicate via a LAN connection. For a direct connection, a cross-over LAN cable is required. Alternately, both analyzers can be on a local area network.</p> <p>Recommended Accessory</p> <p>F. N9910X-825, GPS Antenna. Necessary if Option 307 is ordered.</p>												
10. What is included with Option 355?	FieldFox analog demodulation has two parts: (1) Tune and listen, and (2) AM/FM metrics. Tune and listen is available with the purchase of the spectrum analyzer option 233. AM/FM metrics becomes available when Option 355 is purchased. AM/FM metrics provides the user with RF spectrum view, demodulated baseband signal waveform, carrier power, frequency deviation, SINAD and more.												
11. What is included with Option 350?	Real-Time Spectrum Analyzer (RTSA) or Option 350 provides real-time measurements on a FieldFox. The FieldFox must be equipped with spectrum analysis capability. The preamplifier option is recommended, as elusive signals often have low power levels. The maximum real-time bandwidth for option 350 is up to 120 MHz with option B10. RTSA includes trace recording and playback capabilities. It does not include a frequency-mask trigger (FMT).												
12. Is Spectrum Analyzer Trace Recording and Playback standard or an option?	<p>Spectrum Analyzer mode (Option 233) does not include Trace Recording and Playback by default. To obtain this capability in SA mode, Option 236 Interference Analyzer and Spectrogram needs to be purchased.</p> <p>RTSA mode (Option 350) does include Trace Recording and Playback by default in RTSA mode.</p> <p>Purchasing RTSA mode (Option 350) does not enable Trace Recording and Playback in SA mode (Option 233).</p> <table border="1"> <thead> <tr> <th>Trace Record/Playback Features</th> <th>SA Mode SA and Interference Analyzer Options 233 and 236</th> <th>RTSA Mode RTSA Option 350</th> </tr> </thead> <tbody> <tr> <td>Record and playback spectrum traces</td> <td>Yes</td> <td>Yes</td> </tr> <tr> <td>Save trace data with GPS time stamp over time</td> <td>Yes</td> <td>Yes</td> </tr> <tr> <td>Record and playback spectrogram data</td> <td>Yes</td> <td>No ¹</td> </tr> </tbody> </table>	Trace Record/Playback Features	SA Mode SA and Interference Analyzer Options 233 and 236	RTSA Mode RTSA Option 350	Record and playback spectrum traces	Yes	Yes	Save trace data with GPS time stamp over time	Yes	Yes	Record and playback spectrogram data	Yes	No ¹
Trace Record/Playback Features	SA Mode SA and Interference Analyzer Options 233 and 236	RTSA Mode RTSA Option 350											
Record and playback spectrum traces	Yes	Yes											
Save trace data with GPS time stamp over time	Yes	Yes											
Record and playback spectrogram data	Yes	No ¹											
13. What are the requirements for Noise Figure (NF) Option 356?	Requires spectrum analyzer mode (Option 233 on combination models), internal preamplifier (Option 235) and DC bias variable voltage source (Option 309) as well as CPU2 processor. An external noise source is also required and FieldFox supports Keysight noise source models 346A/B/C/K40/K01. Also recommended to improve accuracy is an external preamplifier Keysight models U7227A/C/F or U7228A/C/F. Requires accessory item N9910X-713 BNC to SMB cable for DC bias variable voltage source to noise source connection.												
14. What is required for phased array antenna support (Option 360) and 5G NR Over-the-Air (OTA) measurements (Option 378)?	Requires spectrum analyzer mode (Option 233 on combination models) and GPS receiver (Option 307). Highly recommend internal preamplifier (Option 235). N995x/6xB models are required since phased array antenna, which can be ordered as Keysight 85571A-028 or directly from Anokiwave as AWMF-0129, operates at 28 GHz.												
15. What is included with indoor and outdoor mapping (Option 352)?	The FieldFox mapping function is available in the following modes: Channel Scanner (312), Phased-Array Antenna (360), and OTA LTE FDD/TDD (370/371), OTA 5G TF (377), OTA 5G NR (378). Mapping is currently not available in SA or RTSA modes. Outdoor mapping requires the availability of GPS (Option 307). Maps can be saved to the FieldFox internal memory, SD card or USB drive. Using a direct wired LAN connection, FieldFox will automatically access OpenStreetMap (OSM) once location coordinates (latitude and longitude) and zoom levels have been entered the Map Explorer menu. If using the I FieldFox Map Support Tool, OSM map files can be downloaded to a .zip file and imported to FieldFox internal memory. If the FieldFox GPS receiver is enabled and OSM maps have been previously saved to FieldFox with those GPS coordinates, FieldFox can automatically load the corresponding map to match the current GPS coordinates.												
16. What is required for EMF measurements (Option 358)?	Requires triaxial antenna. Supported antenna is AGOS advanced technologies Triaxial Isotropic Antenna model SDIA-6000 30 MHz to 6 GHz. It can also be ordered as Keysight 85572A. EMF measurements are supported with spectrum analyzer mode (Opt 233 on combination models), OTA LTE FDD/TDD (Opt 370/371) and OTA 5G NR (Opt 378).												
17. What is required for N6820ES Surveyor 4D software?	Surveyor 4D software connected to FieldFox spectrum analyzer mode offers a versatile, truly portable spectrum monitoring system that covers VLF to 50 GHz, including 5G millimeter wave bands. The software runs on an external PC or tablet. FieldFox required options include spectrum analyzer mode (Option 233 on combination models), preamplifier (Option 235) and built-in GPS receiver (Option 307). Core Surveyor 4D software for Windows (Option												

Question	Answer
	N6820ES-114) is required to run the Surveyor 4D software. Other Surveyor 4D software optional licenses that are supported include basic modulation recognition application (N6820ES-MR1) and universal signal detection (N6820ES-USD). Requires Surveyor 4D software version 4.3 or later (May 2019). Frequencies above 26.5 GHz will require N995x/6xB models.
18. What is required for 5G NR Over-the-Air (OTA) measurements (Option 378)?	Requires spectrum analyzer mode (Option 233 on combo analyzers), 120 MHz analysis bandwidth (Option B10) and GPS receiver (Option 307). Highly recommend internal preamplifier (Option 235). FR2 frequencies above 26.5 GHz will require N995x/6xB. Additionally, although these OML external mixer products are no longer available for sale, the following information serves primarily as a reference for existing customers who own them. OML Model: M28H2ADC-K
	Supported on FieldFox Models N9916B, N9917B, N9918B, N9936B, N9937B, N9938B
	RF input frequency range 24 to 40 GHz
	IF output frequency range 0.3 to 6.5 GHz
	LO harmonic number 2
	LO input frequency range 12 to 20 GHz
	LO input power -18 to -5 dBm
	Conversion factor IF = 1 GHz 10 dB (typical)
	Noise figure 12 dB (Includes internal IF amplifier)
19. What is required to expand the maximum frequency of FieldFox spectrum analyzer to WR15 (50 – 75 GHz) or WR12 (60 – 90 GHz)?	Requires spectrum analyzer mode (Option 233 on combo analyzers) and the N9910XVDI frequency extension module (Keysight model number for the VDI PSAX), along with appropriate adapters depending on the FieldFox model used.
	N9910XVDI (VDI PSAX Frequency Extension Modules)
	Supported on FieldFox Models N9917B, N9937B, N9938B (typ-N); N9918B, N9938B/Opt 100 (3.5 mm), N9950B, N9960B, N9951B, N9961B, N9952B, N9962B (2.4 mm)
	Description
	N9910XVDI-W15 (VDI WR15 PSAX)
	N9910XVDI-W12 (VDI WR12 PSAX)
	RF frequency band 50 to 75 GHz 60 to 90 GHz
	RF power limits (P1dB, Damage) -10 dBm (est.)/+17 dBm (typ.) -10 dBm (est.)/+17 dBm (typ.)
	IF frequency 100 MHz (min) to 7.5 GHz (max) 100 MHz (min) to 9 GHz (max)
	SSB Conversion Loss (typ.) -8 dB -8 dB
	Noise Figure (typ.) 12 dB 12 dB
	LO harmonic factor 6 6
	Displayed average noise level -155 dBm/Hz (typ.) -155 dBm/Hz (typ.)

- RTSA trace recordings can be recalled and played back in SA mode Spectrogram. This has the added benefit that the measurements are shown 'slower', making it easier for the human eye to decipher the signal content.

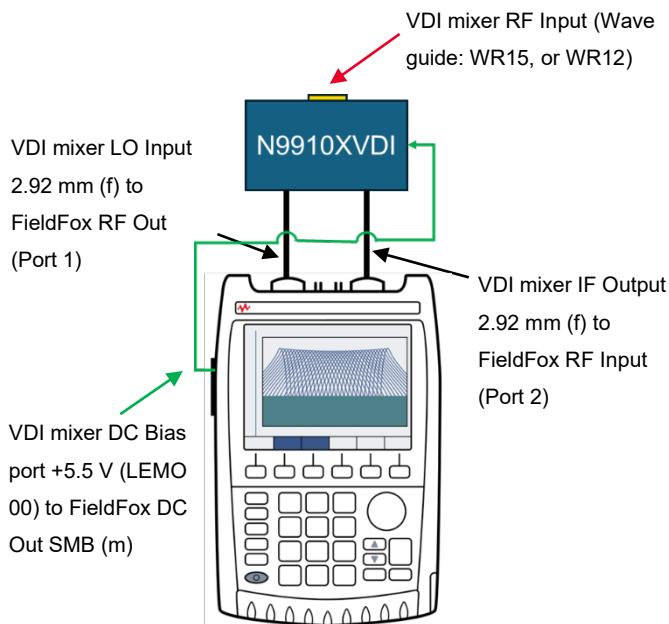

Figure 1a VDI PSAX frequency extender diagram

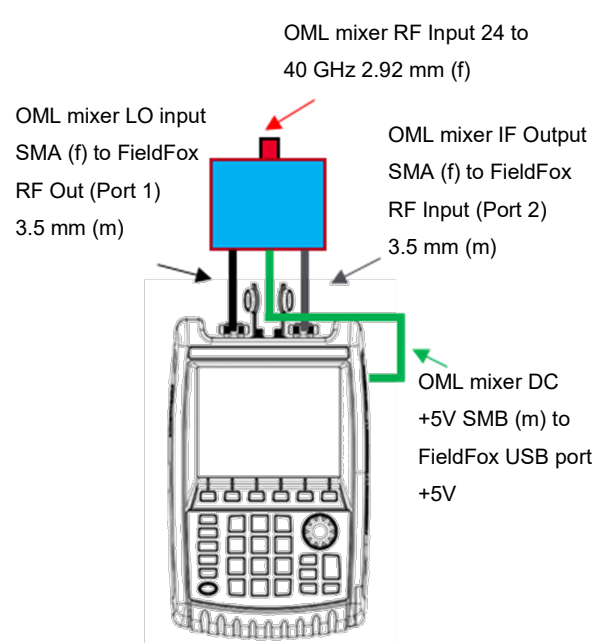

Figure 1b OML frequency extender diagram (For information only, not available for sale)

ERTA System Typical Configuration¹

Item	Description/Options	Quantity
FieldFox	Combo analyzer: Required Options 210, 233. Recommended: 235, 307 SA analyzer: Required: Option 220. Recommended: 235, 307. Not available for N9912C.	2
Power splitter	11667A (Type-N) or 11667B (3.5 mm) or 11667C (2.4 mm)	1
Type-N(m) to Type-N(m) adapter	N9910X-850 (for use with 11667A or Type-N systems)	1
Trigger cables ¹	N9910X-712, SMA(m) to BNC(f)	2 of each
	N9910X-713, SMB(f) to BNC(m)	2 of each
RF test cable	Connecting FieldFox source port 1 to power splitter input	1
RF test cable or adapter	Connecting power splitter output arm to FieldFox port 2	1
RF jumper cable or adapter	Power splitter output arm to DUT input	1
RF jumper cable or adapter	DUT output to FieldFox receiver port 2	1
LAN cable	LAN cable to connect two FieldFox units directly, or the analyzers must be on the LAN	1
N9910X-825	GPS antenna, recommended. Necessary if Option 307 is ordered.	2

1. The trigger cables and LAN cables must be at least as long as the separation distance between the two ends of the DUT.

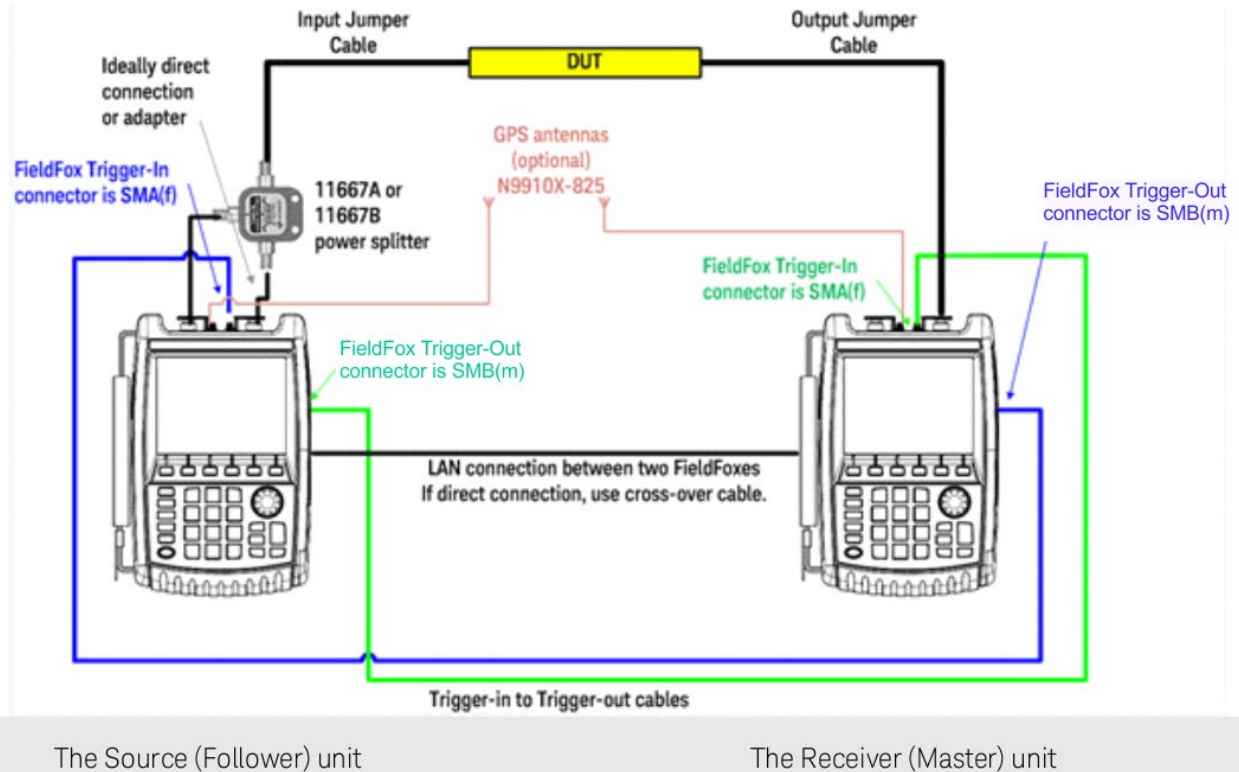
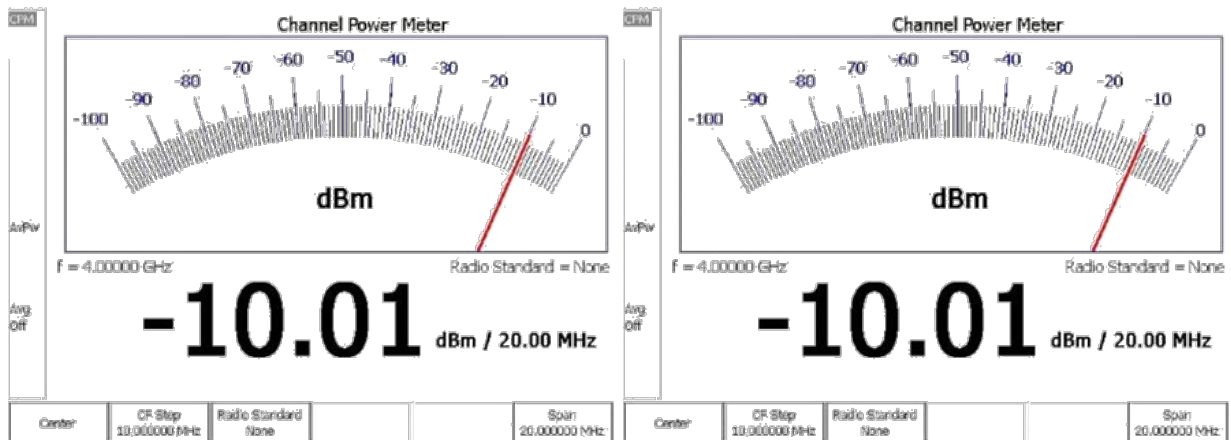

Figure 2. ERTA system diagram

1. Not applicable to N9912C.

FAQs – Applicable to All FieldFox RF and Microwave Analyzers

Question	Answer		
A. What USB power sensors work with Option 302?	All Keysight U2000x Series USB power sensors are supported with FieldFox. Visit: www.keysight.com/find/fieldfoxsupport for an up-to-date listing.		
B. What is the difference between USB power sensor (Option 302) and built-in power meter (Option 310)?	Option 302 USB Power Sensor	Option 310 Built-In Power Meter (Or Channel Power Meter)	
	Description	Option 302 allows users to connect a USB power sensor to FieldFox's USB port and make broadband power measurements	Option 310 is a channelized power measurement capability built into FieldFox analyzers. Maximum bandwidth is 100 MHz.
	External hardware	USB power sensor required	None. Uses internal receiver.
	Power measurement	Broadband diode detector measures all frequencies	Tuned receiver, so measures frequencies within defined channel bandwidth
	Frequency range	Depends on USB sensor	Frequency range of the analyzer
	Settings	Set CW frequency	Set CW frequency, set channel width/span
	Power range	Depends on USB sensor	Depends on channel width and attenuator setting
	Warm-up time	30 minutes to meet accuracy specifications	No warm-up time required
	Accuracy	Depends on USB sensor	InstAlign accuracy: ± 0.5 dB typical for a CW signal. Since the measurement is within a certain frequency channel or bandwidth, to make an accurate measurement, the user needs to know the exact center frequency and the signal's bandwidth and set those accurately.
	Programmable	Yes, via SCPI	Yes, via SCPI
Physical connection	The power sensor can easily be moved to the measurement point, with a USB cable connecting the detector to FieldFox.	The measurement point needs to be connected to FieldFox's RF input port. If an RF jumper cable is used, the user needs to account for the loss of the cable with an offset value (can be entered into the analyzer).	
FieldFox source control	Yes, on/off, and nominal power level control	No access to FieldFox's source from the built-in power meter mode	



Question	Answer
C. What do I need to get GPS information?	<ol style="list-style-type: none"> The recommended GPS solution is to order: <ul style="list-style-type: none"> Option 307 - built-in GPS receiver A GPS antenna such as N9910X-825 Other GPS antennas can also be used The GPS connector on the instrument is SMA (f) Alternatively, you can purchase a USB-based GPS receiver. You do not need to purchase any FieldFox options for the USB-based GPS to work. However, the USB-based GPS only provides time and location data, and time synchronization capability. It cannot be used to increase the frequency accuracy of the instrument.
D. What is the connector for Option 309, DC output?	The DC output has a SMB (m) connector. Recommend ordering N9910X Option 713 bias-tee power cable SMB (f) to BNC (m).
E. What are the connectors for the Reference/ Trigger In and Reference / Trigger Out?	The connector for the Ref/Trig In is SMA (f). Recommend ordering N9910X Option 712 Trig/Ref in SMA (m) to BNC (f) cable. The connector for the Ref/Trig Out is SMB (m). Recommend ordering N9910X Option 713 bias-tee power cable SMB (f) to BNC (m).
F. What is Option 030 remote control capability?	<ol style="list-style-type: none"> Option 030 provides a license for FieldFox to allow remote control via an iOS or Android device. Not supplied by user, but necessary for operation of Option 030 are: <ul style="list-style-type: none"> iOS device: iPad, iPhone, or iPod Touch with iOS 6.1 or higher, or Android device with Android OS 9.0 or higher, with free FieldFox app A WiFi or 3G/4G network connection between FieldFox and iOS device or Android device
G. What USB sensor is required for Option 330?	Option 330 or pulse measurements requires a Keysight USB peak power sensor. Visit www.keysight.com/find/usbsensorsforfieldfox for a list of supported peak power sensors. Average power sensors cannot be used with Option 330, only peak power sensors. The peak power sensor needs to be purchased separately. Option 330 or pulse measurement requires Option 302 and Keysight USB power sensor
H. What measurement capabilities are included with Option 330?	<p>Average power, peak power, and peak to average ratio</p> <p>Analog gauge display and digital display, dBm and watts</p> <p>Relative/absolute measurements, dB or %, minimum and maximum limits</p> <p>Trace graph for pulse profiling with gating</p> <p>Rise time, fall time, pulse width, pulse period, pulse repetition frequency</p>
I. What is included with Option 208?	Option 302, USB power sensor measurements, includes CW power measurements (one frequency at a time). With Option 208 added, you can make swept-frequency power measurements. You can plot source power, gain, and receive power versus frequency. Additionally, the source frequency can be offset from the receiver frequency. The power sensor needs to be purchased separately.

FieldFox RF and Microwave Signal Analyzers

Analyzer Models

Step 1. Select the model that provides the desired frequency range.

Model	Description	Frequency Range ¹	Test Port Connectors
N9933B	4 GHz FieldFox signal analyzer	9 kHz to 4 GHz	Type-N (f)
N9934B	6.5 GHz FieldFox signal analyzer	9 kHz to 6.5 GHz	Type-N (f)
N9935B	9 GHz FieldFox signal analyzer	9 kHz to 9 GHz	Type-N (f)
N9936B	14 GHz FieldFox signal analyzer	9 kHz to 14 GHz	Type-N (f)
N9937B	18 GHz FieldFox signal analyzer	9 kHz to 18 GHz	Type-N (f)
N9938B	26.5 GHz FieldFox signal analyzer	9 kHz to 26.5 GHz	Type-N (f) ²
N9960B	32 GHz FieldFox signal analyzer	9 kHz to 32 GHz	2.4 mm (m)
N9961B	44 GHz FieldFox signal analyzer	9 kHz to 44 GHz	2.4 mm (m)
N9962B	50 GHz FieldFox signal analyzer	9 kHz to 50 GHz	2.4 mm (m)
N9963B	54 GHz FieldFox signal analyzer	9 kHz to 54 GHz	1.8 mm (m)
N9933C	4 GHz FieldFox signal analyzer	3 kHz to 4 GHz	Type-N (f)
N9934C	6.5 GHz FieldFox signal analyzer	3 kHz to 6.5 GHz	Type-N (f)
N9935C	10 GHz FieldFox signal analyzer	3 kHz to 10 GHz	Type-N (f)

1. Useable to 5 kHz for N993x/6xB.

2. Order Option 100 for 3.5 mm (m) test port connectors. With N9938B-100, the spectrum analyzer is built with 3.5 mm test port connectors instead of the standard Type-N (f). Option 100 is a prerequisite for Option 320 for N9938B.

Analyzer Options

Step 2. Select optional measurement capabilities.

You can also add any of these options as a software upgrade in the future.

Option	Description	Prerequisite Options/Notes
Spectrum Analysis		
100	3.5 mm (m) connectors	Only available on N9938B. Option 100 is only available at time of purchase. It is not available as an upgrade. It is a prerequisite for Option 320 for N9938B.
209	Extended Range Transmission Analysis (ERTA)	Requires 220. Recommend 307. Requires two FieldFox units. See FAQ # 9. See page 9 for typical configuration.
220	Full-band tracking generator	CW, CW coupled, and tracking
235	Pre-amplifier	—
236	Interference analyzer and spectrogram	—
238	Spectrum analyzer time gating	—
312	Channel scanner	Require the corresponding option to support a specific app. For example, to support EMF in channel scanner requires 358; to support indoor and outdoor mapping requires 352
320	Reflection measurements (Return Loss, VSWR and Scalar)	320 requires 220 on all models. On N9938B, 320 also requires 100.
350	Real-Time Spectrum Analyzer (RTSA)	Recommend 235. See FAQ # 11
351	I/Q Analyzer (IQA)	—
352	Indoor and outdoor mapping	Requires 307, and at least one of 312, 360, 370, 371, 377 or 378. See FAQ #15
353	IQ streaming	Requires 351
355	Analog demodulation	—
356	Noise Figure (NF)	Requires 235, 309 and accessory item N9910X-713 BNC to SMB cable. See FAQ #13 for external preamplifier and noise source requirements.
357	Pulse generator	—
358	EMF measurements	Requires triaxial isotropic antenna. See FAQ #16
360	Phased array antenna support	Requires phased array antenna. Not applicable to N991x/3x (x≤5). N991x/3xB (x>5) models require an external mixer. See FAQ #14. No external mixer required for N995x/6xB models.
361	EMI measurements	—
366	Interference finder (manual mode)	Requires 307, and 85574A Handheld direction antenna
370/371	Over-the-Air (OTA) LTE FDD/TDD	Requires 307, recommend 235.
377	Over-the-Air (OTA) 5G TF	Requires 307, recommend 235. N991x/3xB (x> 5) models require an external mixer. See FAQ #14. No external mixer required for N995x/6xB models.
378	Over-the-Air (OTA) 5G NR	Requires B10 and 307. Recommend 235. N993xB (x>5) models require external mixer for FR2 frequencies above 26.5 GHz. See FAQ #18. No external mixer required for N996xB models.
390	Directional finding – TDOA node support	Requires 307
B04	Analysis bandwidth, 40 MHz ¹	Recommend 350, 351 or PathWave VSA (formerly 89600 VSA) software
B10	Analysis bandwidth, 120 MHz ¹	Recommend 350, 351, 378 or PathWave VSA (formerly 89600 VSA) software
Power Measurements		
208	USB power sensor meas. versus frequency	Requires 302. See FAQ I
302	USB power sensor support	Need to order USB power sensor ² . See FAQ A
310	Built-in power meter	No power sensor required. See FAQ B
330	Pulse meas. with USB peak power sensor	Requires 302 and USB peak power sensor. See FAQ G and FAQ H
320	Reflection measurements (Return Loss, VSWR and Scalar)	Requires 220 on all models. On N9938B specifically, also requires 100.
System Features		
030	Remote control capability	Requires an iOS device or an Android device
307	GPS receiver	Need to order GPS antenna, N9910X-825. See FAQ C
309	DC bias variable-voltage source	Recommend N9910X-713 cable, See FAQ D
—	Frequency extender support	Optional 350, 351, 360, 370, 371, 377, 378, PathWave VSA software. See Accessories, pages 19-20
Windows Based Software		
89601C	PathWave VSA (89600 VSA) software	—
N6820ES	Surveyor 4D software	Requires 235 and 307, see page 7, FAQ #17
SJ002A	WaveJudge Wireless Analyzer Toolset	—
S9910A	Keysight spectrum management software (KSMS)	Requires 235 and 307
S9911A	Directional Finding - TDOA	Requires S9910A

1. 10 MHz standard.

2. List of compatible sensors available from www.keysight.com/find/fieldfoxsupport.

FieldFox Signal Analyzer FAQs

Question	Answer
1. What is included with the basic signal analyzer?	Basic spectrum analysis, four traces, different detector types, radio standard selection, limit lines Channel power, occupied bandwidth, adjacent channel power, spectrum emission mask AM/FM tune and listen, field strength measurements, antenna factors, frequency counter marker
2. What is included with Option 236?	Interference analyzer and spectrogram Trace playback and recording
3. What is included with Option 320?	Return loss and VSWR Normalization using data/memory
4. What is the difference between Option 320 and the CAT mode on the combo base model?	Option 320 on the N993x/6xB SA offers RL and VSWR. CAT mode on the N991x/5x combo analyzers offer RL and VSWR, DTF, insertion loss, and various calibration capabilities such as OSL.
5. What is included with Option 355?	FieldFox analog demodulation has two parts: (1) Tune and listen, and (2) AM/FM metrics. Tune and listen are available as a standard feature on all N993x/6x FieldFox spectrum analyzers. AM/FM metrics becomes available when Option 355 is purchased. AM/FM metrics provides the user with RF spectrum view, demodulated baseband signal waveform, carrier power, frequency deviation, SINAD and more.
Additional FAQs	FAQs on pages 6 through 11 apply to all microwave FieldFox models.

Upgrades

FieldFox RF and Microwave (Combination) Analyzer Upgrades

N9913/14/15/16/17/18BU, N9913/14/15CU, N9950/51/52/53BU

Information on upgrades is available from: www.keysight.com/find/fieldfoxsupport



Option	Description	Upgrade Contents	Additional Requirements
010	VNA time domain analysis	License key	Requires 210, recommend 211
030	Remote control capability	License key	Requires an iOS device or an Android device
208	USB power sensor measurements versus frequency	License key	Requires 302
209	Extended Range Transmission Analysis (ERTA)	License key	Requires 233 and 210 ¹ , recommend 307
210	VNA transmission and reflection	License key	None
211	VNA full 2-port S-parameters	License key	Requires 210
212	Mixed-mode S-parameters	License key	Requires 210 and 211
215	TDR cable measurements	License key	None
233	Spectrum analyzer	License key	None
235	Preamplifier	License key	Requires 233
236	Interference analyzer and spectrogram	License key	Requires 233
238	Spectrum analyzer time gating	License key	Requires 233
302	External USB power sensor support	License key	None
307	GPS receiver	License key	None
308	Vector voltmeter	License key	Requires 210 and 211 for full VVM functionality
309	DC bias variable-voltage source	License key	Recommend N9910X-713 cable
310	Built-in power meter	License key	None
312	Channel scanner	License key	Requires 233. Require the corresponding option to support a specific app. For example, to support EMF in channel scanner requires 358; to support indoor and outdoor mapping requires 352
330	Pulse measurements	License key	Requires 302 and USB peak power sensor
350	Real-Time Spectrum Analyzer (RTSA)	License key	Requires 233, recommend 235
351	I/Q Analyzer (IQA)	License key	Requires 233
352	Indoor and outdoor mapping	License key	Requires 233, 307, and at least one of 312, 360, 370, 371, 377 or 378.
353	IQ streaming	License key	Requires 233, 351
355	Analog demodulation	License key	Requires 233
356	Noise Figure (NF)	License key ²	Requires 233, 235, 309 and accessory cable N9910X-713

Option	Description	Upgrade Contents	Additional Requirements
357	Pulse generator	License key	Requires 233
358	EMF measurements	License key	Requires 233. Also requires triaxial isotropic antenna. See FAQ #16
360	Phased array antenna support	License key	Requires 233. Also requires phased array antenna. Not applicable to N991xB (x≤5). External mixer required for N991xB (x>5) but not for N995xB. See FAQ #14
361	EMI measurements	License key	Requires 233
366	Interference finder (manual mode)	License key	Requires 233, 307. Also requires 85574A Handheld direction antenna
370	Over-the-Air (OTA) LTE FDD	License key	Requires 233 and 307, recommend 235
371	Over-the-Air (OTA) LTE TDD	License key	Requires 233 and 307, recommend 235
377	Over-the-Air (OTA) 5G TF ³	License key	Requires 233 and 307, recommend 235, not on C model
378	Over-the-Air (OTA) 5G NR	License key	Requires 233, B10, and 307, recommend 235; N991xB models require external mixer for FR2 frequencies above 26.5 GHz. See FAQ #18
390	Directional finding – TDOA node support	License key	Requires 233 and 307
B04	Analysis bandwidth, 40 MHz ⁴	License key	Requires 233. Recommend 350, 351 or PathWave VSA (formerly 89600 VSA) software
B10	Analysis bandwidth, 120 MHz ⁴	License key	Requires 233. Recommend 350, 351, 378 or PathWave VSA (formerly 89600 VSA) software
S70	OTA 5G NR and LTE FDD/TDD cellular measurements, node-locked 12-month subscription ⁵	License key	Requires 233, B10, 235, and 307

- Option 209 is a system based on two FieldFox units. See [FAQ #9](#), for a detailed description of the system requirements.
- See [FAQ #13](#) for external preamplifier and noise source requirements.
- Requires external mixer for N991xB (x>5) models. See [FAQ #14](#). No external mixer required for N995xB.
- 10 MHz standard.
- If the 12-month subscription is expiring and needs to be extended, re-order Option BU-S70 for another period of 12 months.

FieldFox Signal Analyzer Upgrades

N9933/34/35/36/37/38BU, N9933/34/35CU, N9960/61/62/63BU

Information on upgrades is available from: www.keysight.com/find/fieldfoxsupport

Option	Description	Upgrade Contents	Additional Requirements
030	Remote control capability	License key	Requires an iOS device or an Android device
100	3.5 mm connectors	Not applicable	Not applicable
208	USB power sensor measurements versus frequency	License key	Requires 302
209	Extended Range Transmission Analysis (ERTA)	License key	Requires 220 ¹ , recommend 307
220	Full-band tracking generator	License key	None
235	Preamplifier	License key	None
236	Interference analyzer and spectrogram	License key	None
238	Spectrum analyzer time gating	License key	None
302	External USB power sensor support	License key	None
307	GPS receiver	License key	None
309	DC bias variable-voltage source	License key	Recommend N9910X-713 cable
310	Built-in power meter	License key	None
312	Channel scanner	License key	May require the corresponding option to support a specific app. For example, to support EMF in channel scanner requires 358; to support indoor and outdoor mapping requires 352
320	Reflection measurements (Return Loss, VSWR and Scalar)	License key ²	Option 220 for all models Option 100 and 220 for N9938B
330	Pulse measurements	License key	Requires 302 and USB peak power sensor
350	Real-Time Spectrum Analyzer (RTSA)	License key	Recommend 235
351	I/Q Analyzer (IQA)	License key	None
352	Indoor and outdoor mapping	License key	Requires 307, and at least one of 312, 360, 370, 371, 377 or 378.
353	IQ streaming	License key	Requires 351

Option	Description	Upgrade Contents	Additional Requirements
355	Analog demodulation	License key	None
356	Noise Figure (NF)	License key ³	Requires 235, 309 and accessory cable N9910X-713
357	Pulse generator	License key	None
358	EMF measurements	License key	Requires triaxial isotropic antenna. See FAQ #16
360	Phased array antenna support	License key	Requires phased array antenna. Not applicable to N993x (x≤5). External mixer required for N993xB (x>5) but not for N996xB. See FAQ#14
361	EMI measurements	License key	None
366	Interference finder (manual mode)	License key	Requires 307. Also requires 85574A Handheld direction antenna
370	Over-the-Air (OTA) LTE FDD	License key	Requires 307, recommend 235
371	Over-the-Air (OTA) LTE TDD	License key	Requires 307, recommend 235
377	Over-the-Air (OTA) 5G TF ⁴	License key	Requires 307, recommend 235
378	Over-the-Air (OTA) 5G NR	License key	Requires B10 and 307, recommend 235. N993xB models require external mixer for FR2 frequencies above 26.5 GHz. See FAQ #18
390	Directional finding – TDOA node support	License key	Requires 307
B04	Analysis bandwidth, 40 MHz ⁵	License key	Recommend 350, 351 or PathWave VSA (formerly 89600 VSA) software
B10	Analysis bandwidth, 120 MHz ⁵	License key	Recommend 350, 351 or PathWave VSA (formerly 89600 VSA) software
S70	OTA 5G NR and LTE FDD/TDD cellular measurements, node-locked 12-month subscription ⁶	License key	Requires B10, 235, and 307

1. For N9938B, Option 320 is only available as a software upgrade if the spectrum analyzer is already equipped with Option 100, which is 3.5 connectors on the test port. Option 100 must have been ordered at the time of original purchase. It cannot be added later.
2. Option 209 is a system based on two FieldFox units. See [FAQ #9](#), for a detailed description of the system requirements.
3. See [FAQ #13](#) for external preamplifier and noise source requirements.
4. Requires external mixer for N993xB (x>5) models. See [FAQ #14](#). No external mixer required for N996xB.
5. 10 MHz standard.
6. If the 12-month subscription is expiring and needs to be extended, re-order Option BU-S70 for another period of 12 months.

FieldFox N9912C Upgrades

N9912CU

Option	Description	Upgrade Contents	Additional Requirements
CA4	Cable and antenna analyzer 4 GHz	License key	
CA6	Cable and antenna analyzer 6.5 GHz	License key	
CAX	Cable and antenna analyzer 10 GHz	License key	
C46	Cable and antenna analyzer upgrade from 4 to 6.5 GHz	License key	Requires CA4
C4X	Cable and antenna analyzer upgrade from 4 to 10 GHz	License key	Requires CA4
C6X	Cable and antenna analyzer upgrade from 6 to 10 GHz	License key	Requires CA6
NA4	Vector network analyzer 4 GHz	License key	
NA6	Vector network analyzer 6.5 GHz	License key	
NAX	Vector network analyzer 10 GHz	License key	
N46	Vector network analyzer upgrade from 4 to 6.5GHz	License key	Requires NA4
N4X	Vector network analyzer upgrade from 4 to 10 GHz	License key	Requires NA4
N6X	Vector network analyzer upgrade from 6 to 10 GHz	License key	Requires NA6
SA4	Spectrum analyzer 4 GHz	License key	
SA6	Spectrum analyzer 6.5 GHz	License key	
SAX	Spectrum analyzer 10 GHz	License key	
S46	Spectrum analyzer upgrade from 4 to 6.5 GHz	License key	Requires SA4
S4X	Spectrum analyzer upgrade from 4 to 10 GHz	License key	Requires SA4
S6X	Spectrum analyzer upgrade from 6 to 10 GHz	License key	Requires SA6
010	VNA time domain	License key	Requires NA4, NA6, or NAX
030	Remote control capability	License key	Requires an iOS or Android device
208	USB power sensor meas. versus frequency	License key	Requires 302. See FAQ I
215	TDR cable measurements	License key	Requires CA4, CA6, or CAX
220	Tracking generator	License key	Requires SA4, SA6, or SAX
235	Pre-amplifier	License key	Requires SA4, SA6, or SAX
236	Interference analyzer and spectrogram	License key	Requires SA4, SA6, or SAX
238	Spectrum analyzer time gating	License key	Requires SA4, SA6, or SAX
302	USB power sensor support	License key	Need to order USB power sensor. See FAQ A
307	GPS receiver	License key	Need to order GPS antenna, N9910X-825. See FAQ C
308	Vector voltmeter	License key	Requires NA4, NA6, or NAX
309	DC bias variable-voltage source	License key	Recommend N9910X-713 cable. See FAQ D
310	Built-in power meter	License key	No power sensor required. See FAQ B
312	Channel scanner	License key	Requires SA4, SA6, or SAX
330	Pulse meas. with USB peak power sensor	License key	Requires 302 and USB peak power sensor; See FAQ G and FAQ H
350	Real-Time Spectrum Analyzer (RTSA)	License key	Requires SA4, SA6, or SAX. Recommend 235. See FAQ #11
352	Indoor and outdoor mapping	License key	Requires SA4, SA6, or SAX, and 307 and at least one of 312, 370, 371, or 378. See FAQ #15
355	Analog demodulation	License key	Requires SA4, SA6, or SAX
358	EMF measurements	License key	Requires SA4, SA6, or SAX. Also requires triaxial antenna. See FAQ #16
361	EMI measurements	License key	Requires SA4, SA6, or SAX
366	Interference finder (manual mode)	License key	Requires SA4, SA6, or SAX and 307. Also requires 85574A Handheld direction antenna
370	Over-the-Air (OTA) LTE FDD	License key	Requires SA4, SA6, or SAX, and 307. Recommend 235
371	Over-the-Air (OTA) LTE TDD	License key	Requires SA4, SA6, or SAX, and 307. Recommend 235
378	Over-the-Air (OTA) 5G NR	License key	Requires SA4, SA6, or SAX, and B04 and 307. Recommend 235
B04	Analysis bandwidth, 40 MHz ¹	License key	Requires SA4, SA6, or SAX. Recommend 350, 351, or PathWave VSA (formerly, 89600 VSA) software

¹ 10 MHz standard.

Documentation

By default, a printed copy of the User's Guide is not included in FieldFox shipments.

The latest User's Guide (manual) for FieldFox including the N99xxC is available online from: www.keysight.com/find/fieldfoxsupport.

The Service Guide, SCPI Programming Guide, Quick Reference Guide, and Data Link software help file can also be found via the website above.

Calibration Kits

FieldFox analyzers support most standard HP/Agilent/Keysight mechanical calibration kits and all Keysight USB ECal modules. Component list shows calibration components, some calibration kits also include adaptors. Custom calibration kits can be created and uploaded to FieldFox using Data Link software.

Model	Description	Connector	Frequency Range	Components
7-16				
N9910X-802 ¹	3-in-1 OSL Cal kit	7/16 (m)	DC to 4 GHz	Open, short, load (all male)
N9910X-803 ¹	3-in-1 OSL Cal kit	7/16 (f)	DC to 4 GHz	Open, short, load (all female)
85038A	Standard cal kit	7/16	DC to 7.5 GHz	Open, short, load (both female and male)
Type-N, 50 Ω				
N9910X-800 ¹	3-in-1 OSL cal kit	Type-N (m)	DC to 6 GHz	Open, short, load (all male)
N9910X-801 ¹	3-in-1 OSL cal kit	Type-N (f)	DC to 6 GHz	Open, short, load (all female)
85032E	Economy cal kit	Type-N (m)	DC to 6 GHz	Open, short, load (all male)
85514A	4-in-1 OSLT cal kit	Type-N (m)	DC to 9 GHz	Open, short, load, thru (all male)
85515A	4-in-1 OSLT cal kit	Type-N (f)	DC to 9 GHz	Open, short, load, thru (all female)
85032F	Standard cal kit	Type-N	DC to 9 GHz	Open, short, load (both female and male)
85518A	4-in-1 OSLT cal kit	Type-N (m)	DC to 18 GHz	Open, short, load, thru (all male)
85519A	4-in-1 OSLT cal kit	Type-N (f)	DC to 18 GHz	Open, short, load, thru (all female)
85054D	Economy cal kit	Type-N	DC to 18 GHz	Open, short, load, thru (both female and male)
85054B	Standard cal kit	Type-N	DC to 18 GHz	Open, short, fixed load, sliding load (both female and male)
85092C	ECal, 2-ports	Type-N	300 kHz to 9 GHz	Connectors configurable
N4690B/C	ECal, 2-ports	Type-N	300 kHz to 18 GHz	Connectors configurable
N4690D	ECal, 2-ports	Type-N	300 kHz to 18 GHz or DC to 18 GHz	Connectors configurable
N7550A	ECal economy, 2-ports	Type-N	DC to 4 GHz	Connectors configurable
N7551A	ECal economy, 2-ports	Type-N	DC to 6.5 GHz	Connectors configurable
N7552A	ECal economy, 2-ports	Type-N	DC to 9 GHz	Connectors configurable
N7553A	ECal economy, 2-ports	Type-N	DC to 14 GHz	Connectors configurable
N7554A	ECal economy, 2-ports	Type-N	DC to 18 GHz	Connectors configurable

¹ This calibration kit is not eligible for annual re-calibration. There are also no data report calibrations (UK6, 1A7 and A6J). If annual calibration is required, please order 85514A or 85515A.

Type-N, 75 Ω¹				
85036B	Standard cal kit	Type-N 75 Ω	DC to 3 GHz	Open, short, load (both female and male)
85036E	Economy cal kit	Type-N(m) 75 Ω	DC to 3 GHz	Open, short, load, all male
85096C	ECal, 2-ports	Type-N(m) 75 Ω	300 kHz to 3 GHz	Connectors configurable
3.5 mm				
85520A	4-in-1 OSLT	3.5 mm (m)	DC to 26.5 GHz	Open, short, load, thru (all male)
85521A	4-in-1 OSLT	3.5 mm (f)	DC to 26.5 GHz	Open, short, load, thru (all female)
85033D/E	Economy cal kit	3.5 mm	DC to 6/9 GHz	Open, short, fixed load (both female and male)
85052D	Economy cal kit	3.5 mm	DC to 26.5 GHz	Open, short, fixed load (both female and male)
85052B	Standard cal kit	3.5 mm	DC to 26.5 GHz	Open, short, fixed load, sliding load (both female and male)
85052C	Precision TRL kit	3.5 mm	DC to 26.5 GHz	Open, short, fixed load (both female and male), two-line lengths
85093C	ECal, 2-ports	3.5 mm	300 kHz to 9 GHz	Connectors configurable
N4691B ²	ECal, 2-ports	3.5 mm	300 kHz to 26.5 GHz	Connectors configurable
N4691D	ECal, 2-ports	3.5 mm	300 kHz to 26.5 GHz or DC to 26.5 GHz	Connectors configurable
N7550A	ECal economy, 2-ports	3.5 mm	DC to 4 GHz	Connectors configurable
N7551A	ECal economy, 2-ports	3.5 mm	DC to 6.5 GHz	Connectors configurable
N7552A	ECal economy, 2-ports	3.5 mm	DC to 9 GHz	Connectors configurable
N7553A	ECal economy, 2-ports	3.5 mm	DC to 14 GHz	Connectors configurable
N7554A	ECal economy, 2-ports	3.5 mm	DC to 18 GHz	Connectors configurable
N7555A	ECal economy, 2-ports	3.5 mm	DC to 26.5 GHz	Connectors configurable
2.92 mm (Same as K Connector)				
85561A	4-in-1 OSLT cal kit	2.92 mm (f)	DC to 40 GHz	Open, short, fixed load, thru (all female)
85562A	4-in-1 OSLT cal kit	2.92 mm (m)	DC to 40 GHz	Open, short, fixed load, thru (all male)
85056KE01 ³	Standard cal kit	2.92 mm	DC to 40 GHz	Open, short, fixed load, sliding load (both female and male)
85056KE02 ⁴	Economy cal kit	2.92 mm	DC to 40 GHz	Open, short, fixed load (both female and male)
N4692A ²	ECal	2.92 mm	10 MHz to 40 GHz	Connectors configurable
2.4 mm				
85563A	3-in-1 OSL cal kit	2.4 mm (f)	DC to 50 GHz	Open, short, fixed load (all female)
85564A	3-in-1 OSL cal kit	2.4 mm (m)	DC to 50 GHz	Open, short, fixed load (all male)
85056D	Economy cal kit	2.4 mm	DC to 50 GHz	Open, short, fixed load (both female and male)
85056A	Standard cal kit	2.4 mm	DC to 50 GHz	Open, short, load, fixed load, sliding load (both female and male)
N4693A ²	ECal	2.4 mm	10 MHz to 50 GHz	Connectors configurable
1.85 mm				
85058E	Economy cal kit	1.85 mm	DC to 67 GHz	Open, short, fixed load (female and male)
N4694A ²	ECal	1.85 mm	10 MHz to 67 GHz	Connectors configurable
N4694D	ECal	1.85 mm	10 MHz to 67 GHz or DC to 67 GHz	Connectors configurable
Waveguide				
N9911X-11x	Econ. waveguide cal kit	WR-137	5.38 to 8.18 GHz	Short, termination, offset length
N9911X-21x	Econ. waveguide cal kit	WR-90	8.2 to 12.5 GHz	Short, termination, offset length
N9911X-31x	Econ. waveguide cal kit	WR-62	11.9 to 18 GHz	Short, termination, offset length
N9911X-41x	Econ. waveguide cal kit	WR-42	17.6 to 26.7 GHz	Short, termination, offset length
X11644A	Waveguide cal kit	WR-90	8.2 to 12.4 GHz	Short, shim, termination, standard section
P11644A	Waveguide cal kit	WR-62	12.4 to 18 GHz	Short, shim, termination, standard section
K11644A	Waveguide cal kit	WR-42	18 to 26.5 GHz	Short, shim, termination, standard section

1. Recommend ordering quantity 2 of N9910X Option 846, 50 to 75 Ω adapter.
2. Product is discontinued.
3. Same as Maury's 8770C47.
4. Same as Maury's 8770D47.

Accessories

Cables

All Cables Listed Below are Rugged Phase-Stable Cables

Model	Cable Connector	Other Cable Connector	Max Frequency	Length (ft)	Length (m)
N9910X-700	Type-N (m)	Type-N (f)	18 GHz	3.28 ft	1 m
N9910X-701	Type-N (m)	Type-N (m)	18 GHz	3.28 ft	1 m
N9910X-704	Type-N (m)	TNC (f)	13 GHz	5 ft	1.5 m
N9910X-705	Type-N (m)	TNC (m)	13 GHz	5 ft	1.5 m
N9910X-708	3.5 mm (m)	3.5 mm (f)	26.5 GHz	3.28 ft	1 m
N9910X-709	3.5 mm (f)	3.5 mm (f)	26.5 GHz	3.28 ft	1 m
N9910X-714	2.4 mm (f)	2.4 mm (m)	50 GHz	3.28 ft	1 m
N9910X-715	2.4 mm (f)	2.4 mm (f)	50 GHz	3.28 ft	1 m
N9910X-716	Type-N (m)	Type-N (m)	18 GHz	2 ft	0.61 m
N9910X-718	2.4 mm (f)	K / 2.92 mm (m)	40 GHz	3 ft	0.914 m
N9910X-810	Type-N (m)	Type-N (m)	8 GHz	5 ft	1.5 m
N9910X-811	Type-N (m)	Type-N (f)	8 GHz	5 ft	1.5 m
N9910X-812	Type-N (m)	Type-N (m)	8 GHz	12 ft	3.6 m
N9910X-813	Type-N (m)	Type-N (f)	8 GHz	12 ft	3.6 m
N9910X-814	Type-N (m)	7/16 (m)	6 GHz	5 ft	1.5 m
N9910X-815	Type-N (m)	7/16 (m)	6 GHz	12 ft	3.6 m
N9910X-816	Type-N (m)	Type-N (f)	6 GHz	3.28 ft	1 m
N9910X-817	Type-N (m)	Type-N (m)	6 GHz	3.28 ft	1 m

Preamplifiers

U7227A	USB preamplifier, 10 MHz to 4 GHz	www.keysight.com/find/U7227A
U7227C	USB preamplifier, 100 MHz to 26.5 GHz	www.keysight.com/find/U7227C
U7227F	USB preamplifier, 2 to 50 GHz	www.keysight.com/find/U7227F
U7228A	USB preamplifier, 10 MHz to 4 GHz	www.keysight.com/find/U7228A
U7228C	USB preamplifier, 100 MHz to 26.5 GHz	www.keysight.com/find/U7228C
U7228F	USB preamplifier, 2 to 50 GHz	www.keysight.com/find/U7228F

Noise Sources

346A/B/C/CK01/CK40	Noise source family	www.keysight.com/find/346noisesources
U1832A	USB smart noise source, 10 MHz to 18 GHz, 5 dB ENR nominal	www.keysight.com/us/en/product/U1832A/
U1832B	USB smart noise source, 10 MHz to 26.5 GHz, 5 dB ENR nominal	www.keysight.com/us/en/product/U1832B/
U1832C	USB smart noise source, 500 MHz to 50 GHz, 5 dB ENR nominal	www.keysight.com/us/en/product/U1832C/
U1833A	USB smart noise source, 10 MHz to 18 GHz, 15 dB ENR nominal	www.keysight.com/us/en/product/U1833A/
U1833B	USB smart noise source, 10 MHz to 26.5 GHz, 15 dB ENR nominal	www.keysight.com/us/en/product/U1833B/
U1833C	USB smart noise source, 500 MHz to 50 GHz, 15 dB ENR nominal	www.keysight.com/us/en/product/U1833C/
U1833D	USB smart noise source, 500 MHz to 60 GHz, 10 dB ENR nominal	www.keysight.com/us/en/product/U1833D/

Antennas

N9910X-820	Antenna, directional, multiband, 800 to 2500 MHz, 10 dBi, Type-N (f)
N9910X-821	Antenna, telescopic whip, 70 MHz to 1 GHz, BNC (m)
N9910X-822	Antenna, directional, log periodic, 600 MHz to 9 GHz, Type-N (f)
N9910XA-823 ¹	Antenna, cellular narrowband, 824 to 869 MHz, Type-N (f)
N9910XA-824 ¹	Antenna, cellular narrowband, PCS 1850 to 1990 MHz, Type-N (f)
N9910X-825	Antenna, GPS, active, SMA (m)
85571A-028 ¹	5G Phased Array Antenna 28 GHz
85572A-006	Triaxial Isotropic Antenna 400 MHz to 6 GHz
85572A-007	Triaxial Isotropic Antenna 30 MHz to 6 GHz
85574A-100	20 MHz to 8.5GHz direction antenna with digital compass
85574A-209	Frequency extension for 85574A option 100 - 9 kHz to 20 MHz

1. Currently not RoHS compliant.

RF and Microwave Adapters

83059A	Coaxial adapter, 3.5 mm (m) to 3.5 mm (m), 26.5 GHz
83059B	Coaxial adapter, 3.5 mm (f) to 3.5 mm (f), 26.5 GHz
83059C	Coaxial adapter, 3.5 mm (m) to 3.5 mm (f), 26.5 GHz
N9910X-601	Coaxial adapter, NMD 2.4 mm (f) to Type-N (f), 50-ohm, 18 GHz
N9910X-602	Coaxial adapter, NMD 2.4 mm (f) to 2.92 mm/K (f), 40 GHz
N9910X-603	Coaxial adapter, NMD 2.4 mm (f) to 3.5 mm (f), 26.5 GHz
N9910X-604	3.5 mm NMD (f) to 3.5 mm (f) adapter, 26.5 GHz
N9910X-605	3.5 mm NMD (f) to Type-N (f) adapter, 18 GHz
N9910X-843	Coaxial adapter, Type-N (m) to 7/16 DIN (f)
N9910X-845	Adapter kit: Type-N (f) to 7/16 DIN (f), Type-N (f) to 7/16 DIN (m), Type-N (f) to Type-N (f)
N9910X-846	Coaxial adapter, Type-N (m) 50 ohm to Type-N (f) 75 ohm
N9910X-847	Adapter kit: Type-N (f) to TNC (m) adapter, Type-N (f) to TNC (f) adapter, 10 GHz
N9910X-848	Coaxial adapter, Type-N (f) to 3.5 mm (f), 18 GHz
N9910X-849	Coaxial adapter, Type-N (f) to 3.5 mm (m), 18 GHz
N9910X-850	Coaxial adapter, Type-N (m) to Type-N (m), 18 GHz
N9910X-851	Coaxial adapter, Type-N (f) to Type-N (f), 18 GHz
N9910X-852	Coaxial adapter, Type-N (m) to Type-N (f), 18 GHz
N9910X-856	Coaxial adapter, 2.4 mm (f) to 2.4 mm (f), 50 GHz
N9910X-857	Coaxial adapter, 2.4 mm (f) to 2.92 mm/K (f), 40 GHz

Keysight N9910XVDI (or VDI PSAX) Frequency Extender Modules

The VDI PSAX frequency extenders, covering WR15 (50 to 75 GHz) or WR12 (60 GHz to 90 GHz), can be purchased either from Keysight as N9910XVDI (with an option for different millimeter-wave frequency range, shown below) or directly through Virginia Diodes, Inc (VDI). If purchased directly from VDI, contact VDI (www.vadiodes.com/en/products/portable-spectrum-analyzer-extendors-psax) or contact a Keysight representative for assistance.

FieldFox operating modes that support frequency extenders include: Spectrum analyzer, real-time spectrum analyzer, I/Q analyzer, and PathWave vector signal analysis software (formerly 89600 VSA).

Keysight Model/Option	Keysight Item Description	VDI Model/Option	Frequency Range
N9910XVDI	VDI frequency extenders for FieldFox	-	-
N9910XVDI-W15	WR15 frequency extender, 50 to 75 GHz	WR15PSAX	50 to 75 GHz
N9910XVDI-W12	WR12 frequency extender, 60 to 90 GHz	WR12PSAX	60 to 90 GHz

VDI Frequency Extender Module Adapter Kits

VDI PSAX frequency extender module adapter kits simplify the connection to FieldFox units with RF ports of Type-N, 3.5 mm, or 2.4 mm. Be sure to select the correct adapters for the VDI PSAX frequency extender based on the FieldFox model and its specific RF port type.

Option Number	Description	Fit to FieldFox Models
N9910XVDI-101	Male-SMA to female-SMA male, Qty 2 of 1250-3851	N9918B or N9938B with option 100 (RF ports: 3.5 mm (m))
N9910XVDI-102	Male-type-N to male-SMA, Qty 2 of 1250-1636	N9917B/N9937B/N9938B (RF ports: Typ-N (f))
N9910XVDI-103	Female-2.4 mm to male-SMA, Qty 2 of 11901-60004	N9950B/N9960B/N9951B/N9961B/N9952B/N9962B (RF ports: 2.4 mm (m))
N9910XVDI-104	Female-SMA to male-SMA adapter, right angle, for connecting GPS antenna or Trigg/Ref input	All FieldFox models
Other VDI PSAX-Related Accessories		Notes
N9910XVDI-100	DC power cable replacement	Every VDI PSAX module shipped with a DC power cable as standard. This option is for replacement only.

Other RF and Microwave Accessories

Model	Description
N9910X-860	Fixed attenuator, 40 dB, 100 W, DC to 3 GHz, Type-N (m) to Type-N (f)
N9910X-861	Fixed attenuator, 40 dB, 50 W, DC to 8.5 GHz, Type-N (m) to Type-N (f)
N9910X-874 ¹	External bias-tee, 2.5 MHz to 6 GHz, 1 W, 0.5 A
N9910X-886	Torque wrench, 17 mm, 90 N-cm (8 in-lb), used for connecting with 3.5 mm, 2.4 mm, or 1.85 mm connectors
N9910X-712	Trig/Ref in Cable SMA (m) to BNC (f), 1 m or 3.28 ft
N9910X-713	Bias-tee power cable SMB (f) to BNC (m), 1 m or 3.28 ft

Other FieldFox Accessories

N9910X-876	Extra high-capacity battery
N9910X-872	External battery charger
N9910X-873	AC/DC adapter
N9910X-875	DC car charger and adapter
N9910X-880	Extra soft carrying case with backpack and shoulder strap
N9910X-881	Hard transit case
N9910X-886	Torque wrench, 17 mm, 90 N-cm (8 in-lb), recommended for N995xA and N996xA analyzers
N9910X-895	Magnetic mount base for antenna















1. Also recommend ordering N9910X-713 Bias-Tee Power Cable, SMB(f) to BNC(m), 3.28 ft., to connect to the FieldFox DC source.

Keysight Power Sensors Supported with Fieldfox (Options 208, 302, or 330)



Model Number	USB or LAN	Sensor Type	Frequency and Power Range
U2000A	USB	Average	10 MHz to 18 GHz, -60 dBm to +20 dBm
U2000B	USB	Average	10 MHz to 18 GHz, -30 dBm to +44 dBm
U2000H	USB	Average	10 MHz to 18 GHz, -50 dBm to +30 dBm
U2001A	USB	Average	10 MHz to 6 GHz, -60 dBm to +25 dBm
U2001B	USB	Average	10 MHz to 6 GHz, -30 dBm to +44 dBm
U2001H	USB	Average	10 MHz to 6 GHz, -50 dBm to +30 dBm
U2002A	USB	Average	50 MHz to 24 GHz, -60 dBm to +20 dBm
U2002H	USB	Average	50 MHz to 24 GHz, -50 dBm to +30 dBm
U2004A	USB	Average	9 kHz to 6 GHz, -60 dBm to +20 dBm
U2021XA	USB	Average and peak	50 MHz to 18 GHz, -30 dBm to +20 dBm
U2022XA	USB	Average and peak	50 MHz to 40 GHz, -30 dBm to +20 dBm
U2041XA	USB	Average	10 MHz to 6 GHz, -70 dBm to +26 dBm
U2042XA	USB	Average and peak	10 MHz to 6 GHz, -70 dBm to +26 dBm
U2043XA	USB	Average	10 MHz to 18 GHz, -70 dBm to +26 dBm
U2044XA	USB	Average and peak	10 MHz to 18 GHz, -70 dBm to +26 dBm
U2051XA	USB	Average	10 MHz to 6 GHz, -70 dBm to +26 dBm
U2052XA	USB	Average	10 MHz to 18 GHz, -70 dBm to +26 dBm
U2053XA	USB	Average	10 MHz to 33 GHz, -70 dBm to +26 dBm
U2054XA	USB	Average	10 MHz to 40 GHz, -70 dBm to +20 dBm
U2055XA	USB	Average	10 MHz to 50/53 GHz, -70 dBm to +20 dBm
U2056XA	USB	Average	10 MHz to 54 GHz, -70 dBm to +20 dBm (≤ 50 GHz), to +15 dBm (≤ 54 GHz)
U2057XA	USB	Average	10 MHz to 67 GHz, -70 dBm to +20 dBm (≤ 50 GHz), to +15 dBm (≤ 54 GHz), to +10 dBm (≤ 67 GHz)
U2062XA	USB	Average and peak	10 MHz to 18 GHz, -70 dBm to +26 dBm
U2063XA	USB	Average and peak	10 MHz to 33 GHz, -70 dBm to +26 dBm
U2064XA	USB	Average and peak	10 MHz to 40 GHz, -70 dBm to +20 dBm
U2065XA	USB	Average and peak	10 MHz to 50/53 GHz, -70 dBm to +20 dBm
U2066XA	USB	Average and peak	10 MHz to 54 GHz, -70 dBm to +20 dBm (≤ 50 GHz), to +15 dBm (≤ 54 GHz)
U2067XA	USB	Average and peak	10 MHz to 67 GHz, -70 dBm to +20 dBm (≤ 50 GHz), to +15 dBm (≤ 54 GHz), to +10 dBm (≤ 67 GHz)
U8481A	USB	Average	10 MHz to 18 GHz, -35 dBm to +20 dBm
U8485A	USB	Average	10 MHz to 33 GHz, -35 dBm to +20 dBm
U8487A	USB	Average	10 MHz to 50 GHz, -35 dBm to +20 dBm
U8488A	USB	Average	10 MHz to 67 GHz, -35 dBm to +20 dBm
U8489A	USB	Average	DC to 120 GHz, -35 dBm to +20 dBm
L2051XA	LAN	Average	10 MHz to 6 GHz, -70dBm to +26 dBm
L2052XA	LAN	Average	10 MHz to 18 GHz, -70dBm to +26 dBm
L2053XA	LAN	Average	10 MHz to 33 GHz, -70dBm to +26 dBm
L2054XA	LAN	Average	10 MHz to 40 GHz, -70dBm to +20 dBm
L2055XA	LAN	Average	10 MHz to 50/53 GHz, -70dBm to +20 dBm
L2056XA	LAN	Average	10 MHz to 54 GHz, -70 dBm to +20 dBm (≤ 50 GHz), to +15 dBm (≤ 54 GHz)
L2057XA	LAN	Average	10 MHz to 67 GHz, -70 dBm to +20 dBm (≤ 50 GHz), to +15 dBm (≤ 54 GHz), to +10 dBm (≤ 67 GHz)
L2061XA	LAN	Average and peak	10 MHz to 6 GHz, -70dBm to +26 dBm
L2062XA	LAN	Average and peak	10 MHz to 18 GHz, -70dBm to +26 dBm
L2063XA	LAN	Average and peak	10 MHz to 33 GHz, -70dBm to +26 dBm
L2064XA	LAN	Average and peak	10 MHz to 40 GHz, -70dBm to +20 dBm
L2065XA	LAN	Average and peak	10 MHz to 50/53 GHz, -70dBm to +20 dBm
L2065XT	LAN	Average and peak	10 MHz to 53 GHz, -70dBm to +20 dBm
L2066XA	LAN	Average and peak	10 MHz to 54 GHz, -70 dBm to +20 dBm (≤ 50 GHz), to +15 dBm (≤ 54 GHz)
L2067XA	LAN	Average and peak	10 MHz to 67 GHz, -70 dBm to +20 dBm (≤ 50 GHz), to +15 dBm (≤ 54 GHz), to +10 dBm (≤ 67 GHz)
L2065XT	LAN	Thermal Vacuum Compliance	10 MHz to 53 GHz, -70 dBm to +20 dBm
L2066XT	LAN	Thermal Vacuum Compliance	10 MHz to 54 GHz, -70 dBm to +20 dBm (≤ 50 GHz), to +15 dBm (≤ 54 GHz)
L2067XT	LAN	Thermal Vacuum Compliance	10 MHz to 67 GHz, -70 dBm to +20 dBm (≤ 50 GHz), to +15 dBm (≤ 54 GHz), to +10 dBm (≤ 67 GHz)
U2049XA	LAN	Average and peak	10 MHz to 33 GHz, -70dBm to +20 dBm

Description	Accessory	Description	Accessory
N9910X-701 Type-N (m) to Type-N (m) cable, 3.28 ft		N9910X-881 Hard transit case	
N9910X-708 3.5 mm (m) to 3.5 mm (f) cable, 3.28 ft		N9910X-812 Type-N (m) to Type-N (m) cable, 12 ft	
N9910X-820 Antenna, directional		N9910X-816 Type-N (m) to Type-N (f) cable, 3.28 ft	
N9910XA-823 Antenna, cellular narrowband		N9910X-821 Antenna, telescopic whip™	
N9910X-822 Antenna, directional		N9910X-848 Coaxial adapter, Type-N(f) to 3.5 mm (f)	
N9910X-825 Antenna, GPS, active		N9910X-875 DC car charger and adapter	
N9910X-876 Extra high-capacity battery		N9910X-873 AD/DC adapter	
N9910X-872 External battery charger		N9910X-874 External bias-tee	
N4690B ¹ 2-port ECal, Type-N, 18 GHz		85054D Economy cal kit, Type-N, 18 GHz	

1. Discontinued

Description	Accessory	Description	Accessory
N9910X-800 3-in-1 OSL cal kit, Type-N (m), 6 GHz		N9910X-801 3-in-1 OSL cal kit, Type-N (f), 6 GHz	
N9910X-811 Type-N (m) to Type-N (f) cable, 5 ft		85520A 4-in-1 OSLT cal kit, 3.5 mm (m), 26.5 GHz	
85514A 4-in-1 OSLT cal kit, Type-N (m), 9 GHz		85521A 4-in-1 OSLT cal kit, 3.5 mm (f), 26.5 GHz	
85515A 4-in-1 OSLT cal kit, Type-N (f), 9 GHz		85518A 4-in-1 OSLT cal kit, Type-N (m), 18 GHz	
85519A 4-in-1 OSLT cal kit, Type-N (f), 18 GHz		85572A Triaxial Isotropic Antenna (Option 85572A-006:400 MHz to 6 GHz; Option 85572A-007: 30 MHz to 6 GHz)	
N9911X-211/212/213/214 WR-90 economical cal kit		85571A-028 ¹ 5G Phase Array Antenna 28 GHz	
N4691B ² 2-port ECal, 3.5 mm, 26.5 GHz		N4692A ² 2.92 mm, 2-port ECal, 40 GHz	

1. Not currently RoHS compliant
2. Discontinued

Description	Accessory	Description	Accessory
N4693A ¹ 2.4 mm 2-port ECal, 50 GHz		N4691D 3.5 mm, 2-port ECal, 26.5 GHz	
N4692D 2.92 mm, 2-port ECal, 40 GHz		N4693D 2.4 mm, 2-port ECal, 50 GHz	
N4694D 1.85 mm, 2-port ECal, 67 GHz		X11644A WR-90 standard cal kit	
85033D/E 3.5 mm cal kit, 9 GHz		85052D 3.5 mm cal kit, 26.5 GHz	
85056D 2.4 mm cal kit, 50 GHz		N9910X-888 Hands free harness (for FieldFox N99xxB/C models only)	
N9910X-895 Magnetic mount base for antenna		85574A Handheld direction finding antenna, 20 MHz (optional 9 kHz) to 8.5 GHz	

1. Discontinued

Note: While some items in this table might undergo changes in appearance without notifications, their technical performance remains unchanged.

Keysight Support Services

Accelerate your learning curve, enhance your test uptime, and confidently guarantee your instrument accuracy with Keysight Support Services. Keysight Services are here to support your test needs with expert technical support, instrument repair and calibration, training, alternative acquisition program options, and more.

A KeysightCare agreement provides dedicated, proactive support through a single point of contact for an extensive group of instruments, software, and solutions to ensure optimal uptime, with fast response times and resolution. Explore the services that are right for you.

Keysight Services

Offering	Benefits
KeysightCare 	KeysightCare provides elevated support for Keysight instruments and software, with access to technical support experts who respond within a specified time and ensure committed repair and calibration turnaround times (TAT). KeysightCare offers multiple service agreement tiers, including KeysightCare Assured, Enhanced, and Application Software Support. See the KeysightCare data sheet for details.
KeysightCare Assured	KeysightCare Assured goes beyond basic warranty with repair services that include committed TAT and unlimited access to technical experts.
KeysightCare Enhanced	KeysightCare Enhanced includes all the benefits of KeysightCare Assured plus Keysight's accurate and reliable Calibration Services , accelerated, and committed TAT, and technical response.
Keysight Support Portal & Knowledge Center	All KeysightCare tiers include access to the Keysight Support Portal where you can manage support and service resources related to your assets such as service requests, and status, or browse the Knowledge Center.
Education Services	Build confidence and gain new skills to make accurate measurements, with flexible Education Services developed by Keysight experts. Including Start-up Assistance.
Alternative Acquisition Options	
KeysightAccess	Reduce budget challenges with a leased-based subscription service, that offers low monthly payments, enabling you to get the instruments, software, and technical support you want for your test needs.

Recommended Services

Maximize your instrument uptime and confidently make accurate measurements by securing technical support, repair, and calibration services with committed response and turnaround times. High-performance instruments include 1 year of KeysightCare Assured. Obtain multi-year KeysightCare upfront to eliminate the need for lengthy and tedious paperwork and yearly requests for maintenance budget. Plus, you benefit from secured service for 2, 3, or 5 years.

Service	Function
KeysightCare Enhanced ¹	Includes Tech Support, Warranty and Calibration
R-55B-001-1	KeysightCare Enhanced – Upgrade 1 year
R-55B-001-2	KeysightCare Enhanced – Extend to 2 years
R-55B-001-3	KeysightCare Enhanced – Extend to 3 years (Recommended)
R-55B-001-5	KeysightCare Enhanced – Extend to 5 years (Recommended)
KeysightCare Assured	Includes Tech Support and Warranty
R-55A-001-2	KeysightCare Assured – Extend to 2 years
R-55A-001-3	KeysightCare Assured – Extend to 3 years
R-55A-001-5	KeysightCare Assured – Extend to 5 years
Start-Up Assistance	
PS-S40-01	Included – instrument fundamentals and operations starter
PS-S40-04	Recommended – instrument fundamentals and operations starter
PS-S40-02	Optional, technology & measurement science standard learning

¹ Available in select countries. For details, please view the [datasheet](#). R-55B-001-2/3/5 must be ordered with R-55B-001-1.