



DCD 5 series 5 kV sr / st / b - series - coupling/decoupling network

The coupling networks from DCD 5 series are coupling/decoupling networks for a maximum amplitude of 5 kV for testing various test pulses on symmetrical and unsymmetrical interconnection lines.

DCD 5 sr

The AMETEK CTS DCD sr - series of coupling decoupling networks are multifunctional CDNs for the application of Surge and Ringwave pulses onto signal/data lines. The standard DCD sr - models combine three different applications; coupling of Surge pulse via capacitor or gas arrestor and coupling of Ring wave pulses via capacitor being required by the relevant standards. The required coupling mode can easily be selected.

The surge coupling GTD (Gas Discharge Tube) is inside a simple jumper and can be changed depends the application with an ABD plug (Avalanche Breaking Diode). There are also two plugs for using an individual external coupling device.

The DCD sr series also has the required decoupling inductors (20 mH) for each line. To protect the measuring system, an interchangeable, pluggable voltage protection module with overvoltage protection for 50 V DC is included in the delivery at the signal/data line inputs on the AE port. Each module protects 4 lines, so that coupling networks with 8 lines require two modules.

AMETEK CTS offers coupling networks for various voltage pulses up to 7 kV (see DCD 7 series) as well as for signal currents up to 4 A. Various modules for 50 V DC and 250 V AC are available for pluggable voltage protection on the AE port.

MAIN FEATURES

- Coupling/decoupling networks according to IEC/EN 61000-4-5, IEC/EN 61000-4-4 and IEC/EN 61000-4-12
- Interchangeable AE port protection modules
- Test voltage up to 5 kV
- Line voltage 50 V, 250 V / up to 4 A
- sr - for unshielded unsymmetrical lines
- st - for unshielded symmetrical lines
- Designed for 4/8 lines (2/4 pairs)
- Automated models for Burst, Surge and Ringwave available

Multifunctional coupling for Surge and Ringwave

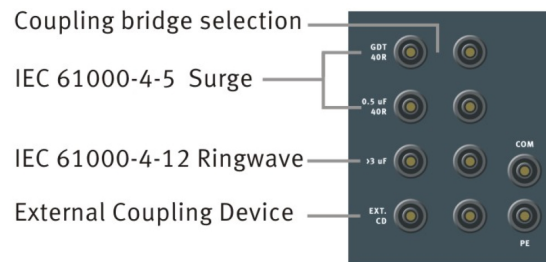

The DCD sr - series of coupling decoupling networks are multifunctional CDNs for the application of Surge and Ringwave pulses onto signal/data lines.

Surge as per IEC 61000-4-5 Ed.3, Figure 9

- Capacitor 0.5 μ F with 40 Ohm
- GDT gas arrestor with 40 Ohm

Ringwave as per IEC 61000-4-12 Ed.3, Figure 8

- Capacitor \geq 3 μ F

5 kV sr / st / b - series - coupling/decoupling network

DCD 5 st

The DCD st - series of coupling decoupling networks are designed to couple Surge pulses (1.2/50 us - 8/20 us) and Telecom Surge pulses (10/700 us) onto unshielded symmetrically operated communication lines. The DCD st - models includes the external coupler (GTD) for coupling via gas arrestor plus the internal matching resistor R_c as per figure 10 of IEC 61000-4-5 Ed.3 with values as per the formula given by the standard. All lines are subjected to the test pulse simultaneously with respect to ground.

The DCD st - series also include the required decoupling inductors of 20 mH for each line (pairwise current compensated). To protect the auxiliary equipment being needed for testing the DUT an additional protection circuit is integrated at the communication line input.

Surge 1.2/50 us

Telecom Surge 10/700 us

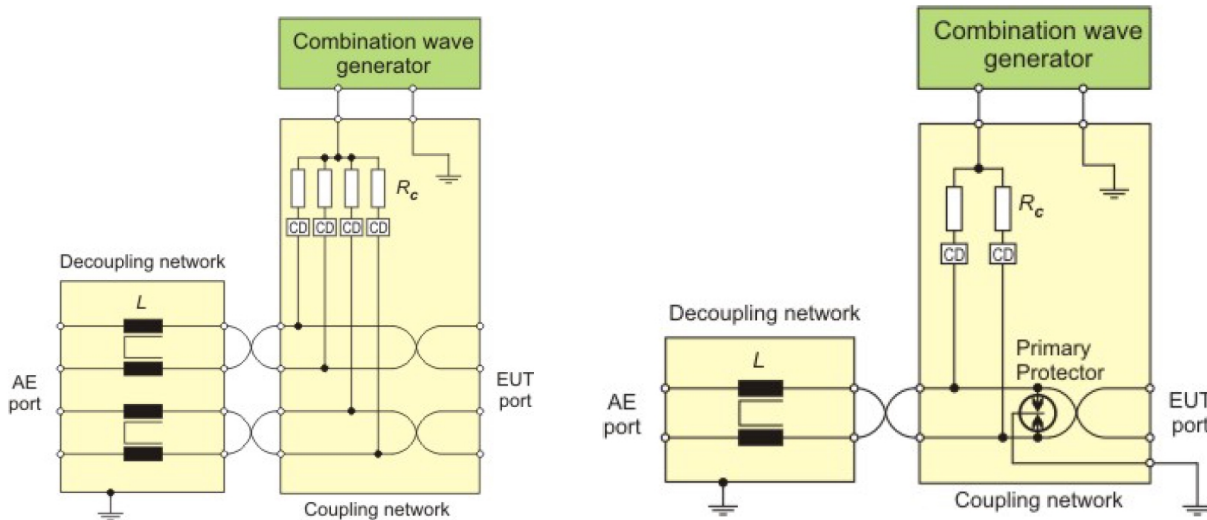

The DCD st - series is designed as per figure A4 of IEC 61000-4-5 Ed.3 without primary protector. If required, an additional primary protector must be integrated according the user specifications. With short circuit bridges and individual designed coupling devices the user can easy modify the coupling mode and number of tested lines to the requirements.

DCD 5-A sr-8-4.1 (with automatic coupling)

The DCD 5-A sr-8-4.1 is the automated version of the DCD 5 sr-8-4 and is used to couple surge and ringwave impulses on up to eight unshielded unsymmetrical interconnection lines (signal/data lines). According to IEC/EN 61000-4-5 resp. IEC/EN 61000-4-12 the pulses are coupled via different coupling elements such as capacitors or gas arrestors depending on the characteristics of the data line signals.

With the DCD 5-A sr-8-4.1, the coupling is switched remotely by the compact NX, thus saving the user the manual selection of the coupling paths. The selected coupling type and the coupling paths are indicated by LEDs.

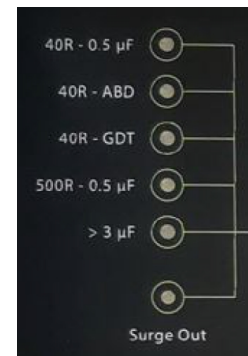

5 kV sr / st / b - series -
coupling/decoupling network

DCD 5-A b-8-4 (with automatic coupling)

The automatic coupling network DCD 5-A b-8-4 is designed for coupling Burst pulses to signal or datalines. The coupling network expands the range of application of the impulse generator of the compact NX series, for automatic testing signal and datalines.

Main characteristics are the advantages for switching the coupling to the signal and data lines automatic with remote controlled by the compact NX generator.

The DCD 5-A b-8-4 is a coupling/decoupling network for coupling EFT / Burst impulses up to 8 unsymmetrical signal- and data-lines. The Burst impulses as per IEC 61000-4-4 are coupled via a 33 nF capacitor into the data lines in replacement of the capacitive coupling clamp. The DCD 5-A b-8-4 couples each line via a 33 nF capacitor. Therefore, the coupled energy to each line is well defined and can be calculated. In comparison to the capacitive coupling clamp, where the energy gives more of a random value, the same value is transferred to each connected line.

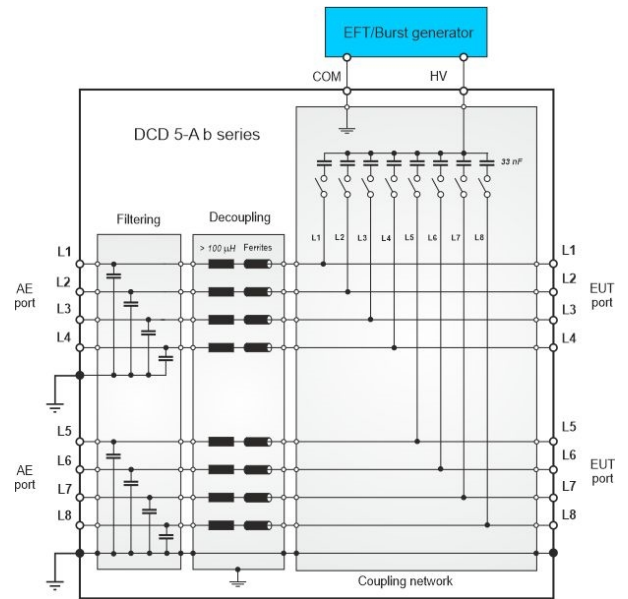

	DCD 5-A sr-8-4.1	DCD 5-A b-8-4
Impulse voltage Surge	5 kV	
Impulse voltage Ringwave	5 kV	
Impulse voltage Burst		5 kV
Line voltage / current	DPM 50/DPM 50-1: max 35 V AC / 50 V DC, 4 A VPM 250-100: max. 250 V AC / 350 V DC, 4 A	max. 300 V AC / 420 V DC, 4 A
Coupling mode	0.5 µF capacitor via 40 Ohm GDT gas arrester via 40 Ohm ABD breaking diode via 40 Ohm 0.5 µF capacitor via 500 Ohm	Common mode and unsymmetrical coupling. C coupling 33 nF to each line, switchable L1, L2, L3, L4, L5, L6, L7, L8, all combinations possible
Ringwave coupling	> 3 µF capacitor	
Decoupling inductance	20 mH, each line	>100 µH
Decoupling / Filter capacitor		Ferrite / 10 nF each line
AE Protection	DPM 50-1 (2 modules with 4 lines included) Impedance to GND: 1 kOhm DPM 50 (optional, 2 required) Impedance to GND: open circuit VPM 250-100 (optional, 2 required) Impedance to GND: 100 kOhm	
Input from generator	4 mm safety banana plugs at back	50 Ohm SHV connector at front
EUT connectors	4 mm safety banana plugs	4 mm safety banana plugs
HV/COM output	Surge-out on front panel, switchable via compact NX generator	

5 kV sr / st / b - series -
coupling/decoupling network

Technical Specifications manual coupling networks

	DCD 5 sr
DCD 5 sr-4-1	5 kV, 4 lines, 1 A
DCD 5 sr-4-4	5 kV, 4 lines, 4 A, intermittent 5 A
DCD 5 sr-8-1	5 kV, 8 lines, 1 A
DCD 5 sr-8-4	5 kV, 8 lines, 4 A, intermittent 5 A
Line voltage	Depends on AE protection module
General data	
Surge coupling	as per Fig. 9 IEC 61000-4-5 Ed. 3, - 0.5 µF capacitor via 40 Ohm - GDT gas arrester (90 V) via 40 Ohm
Ringwave coupling	as per Fig. 8 IEC 61000-4-12 Ed. 3, > 3 µF capacitor
Decoupling inductance	20 mH, each line
AE Protection modules	
DPM 50-1, included	Diode Protection Module 50 V, Impedance to GND: 1 kOhm 1 module is included for every 4 lines. Line voltage: max. 35 V AC, 50 V DC
DPM 50, optional	Diode Protection Module 50 V, Impedance to GND: open circuit 1 module is required for every 4 lines. Line voltage: max. 35 V AC, 50 V DC
VPM 250-100, optional	Varistor Protection Module 250 V, Impedance to GND: 100 kOhm 1 module is required for every 4 lines. Line voltage: max. 250 V AC, 350 V DC
Required modules	DCD with 4 lines: 1 DCD with 8 lines: 2
Optional coupling device	ABD Plug: Avalanche Breaking Diode (140 V), for Surge & Ringwave, max. 7 kV
Connectors	
Input from generator	4 mm safety banana plugs at back
EUT	4 mm safety banana plugs

	DCD 5 st
DCD 5 st-4-1	5 kV, 4 lines (2 pairs), 1 A
DCD 5 st-8-1	5 kV, 8 lines (4 pairs), 1 A
Line voltage	Depends on AE protection module
General data	
Coupling	Selectable: - GDT gas arrester (90 V) - ABD Plug: Avalanche Breaking Diode (140 V) - Individual CD (coupling device)
Matching resistor Rc	Surge Pulse 1.2/50 µs, 8 x 320 Ohm (4 pairs), 4 x 160 Ohm (2 pairs), 2 x 80 Ohm (1 pair)
Matching resistor Rc	Telecom Surge 10/700 µs, 8 x 25 Ohm (8 lines, 4 pairs) 4 x 25 Ohm (4 lines, 2 pairs)
Decoupling	20 mH, pairwise current compensated
Residual voltage at AE port, 5 kV pulse	st-4-1: 88 V (1.2/50 µs), 80 V (10/700 µs) st-8-1: 85 V (1.2/50 µs), 60 V (10/700 µs)
Signal Bandwidth	100 kHz with 600 Ohm load
Data rate	up to 1MBit/s
AE Protection modules	Similar to DCD 5 sr
Included accessories	st-4-1: 1 x DPM 50-1, 4 x GDT (90 V), 4 x ABD (140 V) 4 x short circuit connectors 2 x 0.25 m safety lab cables st-8-1: 2 x DPM 50-1, 8 x GDT (90 V), 8 x ABD (140 V) 8 x short circuit connectors 6 x 0.25 m safety lab cables

	All models
DIMENSION AND WEIGHT	
DCD 5 sr, 5 st, 5-A b	3 HU, 19", 447 mm x 500 mm x 153 mm (LxWxH), 12-22 kg
DCD 5-A sr	6 HU, 19", 447 mm x 500 mm x 286 mm (LxWxH), 20 kg
ENVIRONMENT	
Temperature	10 °C to 40 °C
Humidity	10 % to 80 %, non condensing
Atmospheric pressure	86 kPa (860 mbar) to 106 kPa (1060 mbar)