

RAPPORT DE SPÉCIFICATIONS DE PRODUIT

NOM DU PROJET: _____

INFORMATION SUPPLÉMENTAIRE: _____

QUANTITÉ REQUISE: _____

NUMÉRO DE PRODUIT: **94187A**

DÉTAILS DU PRODUIT

- **Type de luminaire:** Luminaire suspendu
- **Diamètre:** 6 7/8" (174 mm)
- **Hauteur:** 72" (1830 mm) max.
- **Poids:** 1.367 lbs. (0.620 kgs.)
- **Puissance en watts (maximum):** 1 x 100W
- **Type d'ampoule:** A19
- **Fini:** Noir mat
- **Abat-jour:** Noir mat
- **Matériel:** Acier
- **Type d'installation:** Relié à la boîte électrique

PHOTO

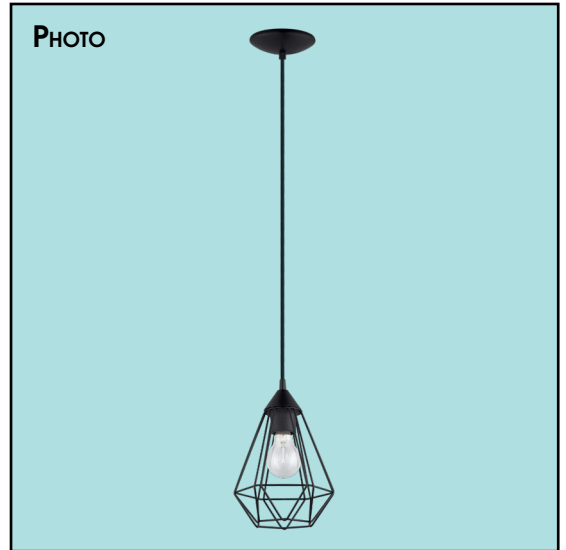

DESSIN DE LIGNE

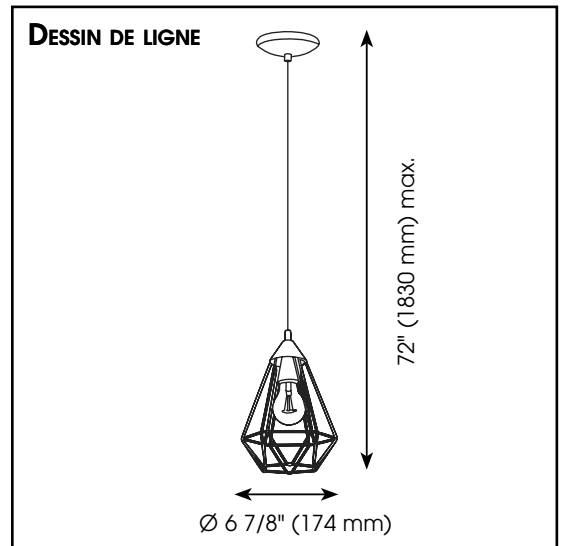

QUALIFICATIONS

- c-UL-us et c-ETL-us Liste
- Convient aux emplacements secs

FEUILLES D'INSTRUCTIONS

- Français et anglais inclus

AUTRES INFORMATIONS

- **UPC:** 9008606143009
- **Nom du produit:** Tarbes
- **Verre de Remplacement:** N/A

EGLO Canada



PRODUCT SPECIFICATIONS REPORT

PROJECT NAME: _____

ADDITIONAL INFORMATION: _____

QUANTITY REQUIRED: _____

PRODUCT NUMBER: **94187A**

PRODUCT DETAILS

- **Fixture Type:** Suspended Light
- **Diameter:** 6 7/8" (174 mm)
- **Height:** 72" (1830 mm) max.
- **Weight:** 1.367 lbs. (0.620 kgs.)
- **Bulb Wattage (maximum):** 1 x 100W
- **Bulb Type:** A19
- **Finish:** Matte Black
- **Shade:** Matte Black
- **Material:** Steel
- **Installation Type:** Hardwire (Standard 4" Outlet Box)

PHOTO



LINE DRAWING

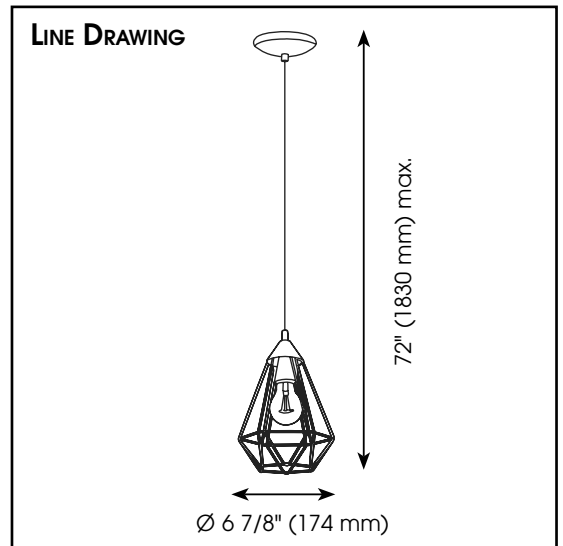

QUALIFICATIONS

- c-UL-us and c-ETL-us Listed
- Suitable for dry locations

INSTRUCTION SHEETS

- Included in English & French

OTHER INFORMATION

- **UPC:** 9008606143009
- **Series Name:** Tarbes
- **Glass Replacement:** N/A

EGLO Canada

20700 route Transcanadienne | Baie-D'Urfé | Québec | Canada | H9X 4B7 | Tel. 514-457-5483 | Fax 514-457-5487 | E-Mail: info-canada@eglo.com | www.eglo.com

