

THIS DOCUMENT IS FOR REFERENCE ONLY AND IS PROPRIETARY INFORMATION BELONGING TO INTERNATIONAL FILTER PRODUCTS UNAUTHORIZED COPIES OR USE FOR OTHER PURPOSES STRICTLY PROHIBITED.

REVISIONS				
ZONE	REV	DESCRIPTION	DATE	APPROVED
	-	Production Release	5/30/2019	CD Morland
	A	CHANGED FROM STRAIT DIP TUBE TO CURVED DIP TUBE	6/4/2019	CD Morland
	B	CHANGED LEGS, ADDED CASTERS, ADDED DIMENSION, AND CHANGED NOTES	8/21/2019	CD Morland

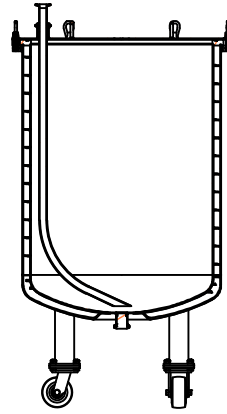

SECTION F-F
SCALE 0.04 : 1

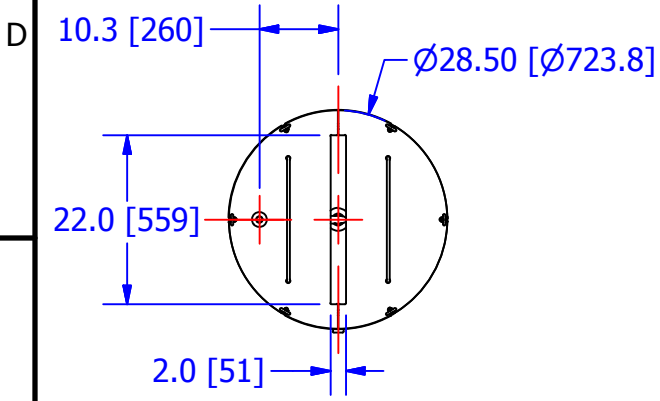
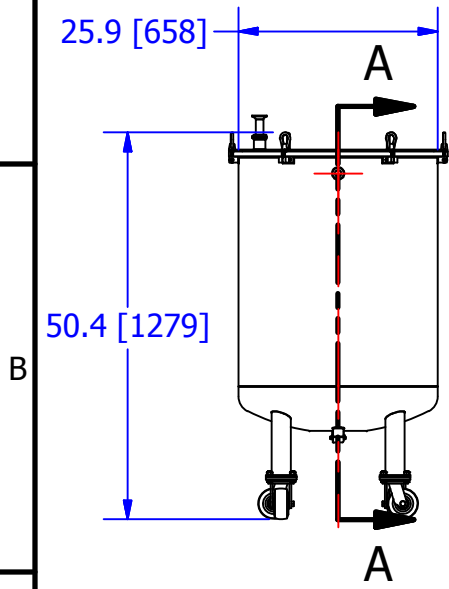

25.59 [650.0]
OUTER JACKET ID

23.60 [599.4]
INNER JACKET ID

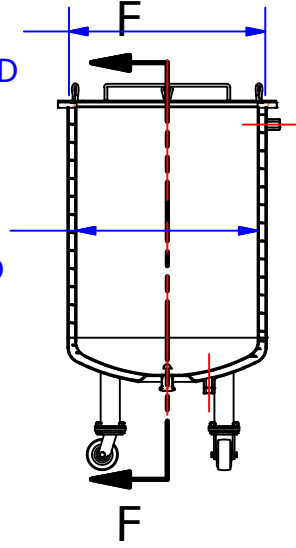

SECTION A-A
SCALE 0.04 : 1

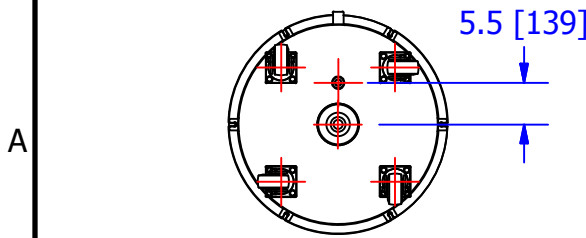

NOTES:

- 1.0 MATERIAL: 4mm THK 316L SS FOR WETTED SURFACES.
- 2.0 WORK VOLUME: 200L (52.8 GALLONS)
- 2.0 THE DRAIN PORT: 1.5" TRI-CLAMP
- 3.0 THE PROCESS VESSEL MUST BE JACKETED ON THE OUTSIDE, JACKET MATERIAL: 4mm 304 SS
- 4.0 INTERNAL WETTED SURFACES ARE 16 RA FINISH; EXTERNAL EXPOSED SURFACES ARE 25 RA FINISHED.
- 5.0 ALL SURFACES ARE TO BE PASSIVATED & ELECTRO-POLISHED.
- 6.0 GASKET MATERIAL: EPDM
- 7.0 THE DESIGN PRESSURE OF THE JACKET IS 100 PSI [6.8 BAR] @ 285°F [126°C]
- 8.0 JACKET HAS BAFFLES TO ENSURE FLUID CIRCULATES EVENLY AROUND THE PROCESS FLUID VESSEL.
- 9.0 THE JACKET FLUID IS REFRIGERATION COOLANT, INLET/OUTLET PORT: 3/4" NPT
- 10.0 FOUR LEGS ARE WELDED FOR SUPPORT.

DRAWN YA Zanki 1/17/2019 CHECKED A. Aziz 2/4/2019 APPROVED CD Morland 2/4/2019	International Filter Products 11070 Fleetwood St., Unit B Sun Valley, CA 91352 PHONE: 818-504-8115 FAX: 818-841-2947 email: www.internationalfilterproducts.com	TITLE TANK, ELLIPTICAL, JACKETED, 200L
UNLESS OTHERWISE SPECIFIED DIMENSIONS ARE IN INCHES DECIMALS FRACTIONS +/- 1/16 X +/- .030 ANGLES +/- 1/2 XX +/- .015 SURFACE ROUGHNESS 125 XXX +/- .005 CONCENTRICITIES .010 (FIM) INTERNAL RADII .015~.030 BREAK CORNERS .005~.015	SIZE A SCALE NA	ISOF NO N/A DWG NO IFP-021-1822C WEIGHT N/A SHEET 1 OF 2

THIS DOCUMENT IS FOR REFERENCE ONLY AND IS PROPRIETARY INFORMATION BELONGING TO INTERNATIONAL FILTER PRODUCTS UNAUTHORIZED COPIES OR USE FOR OTHER PURPOSES STRICTLY PROHIBITED.

3/4 NPT
JACKET PORT



3/4 NPT
JACKET PORT

1.5" TC DRAIN PORT
WITH PLUG

LIFTING HANDLES

DIP TUBE

SPLIT COVER

6X SWING AWAY BOLTS

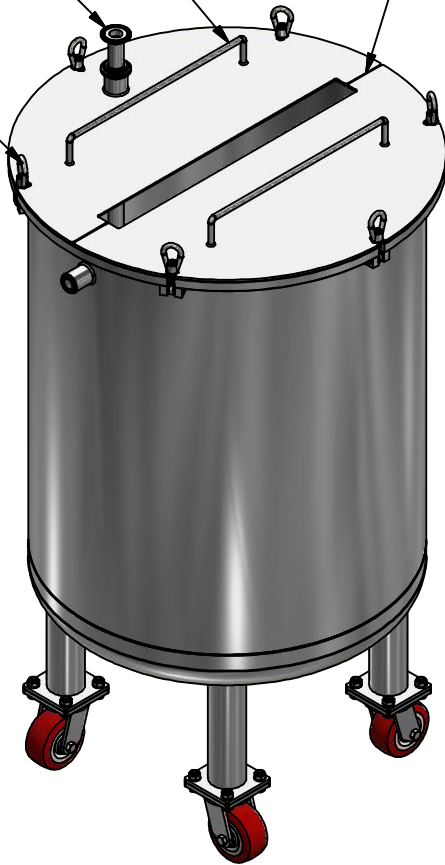

DRAWN YA Zanki	1/17/2019
CHECKED A. Aziz	2/4/2019
APPROVED CD Morland	2/4/2019

International Filter Products

11070 Fleetwood St., Unit B
Sun Valley, CA 91352
PHONE: 818-504-8115
FAX: 818-841-2947
email: www.internationalfilterproducts.com

UNLESS OTHERWISE SPECIFIED
DIMENSIONS ARE IN INCHES

DECIMALS	FRACTIONS +/- 1/16
X +/- .030	ANGLES +/- 1/2
XX +/- .015	SURFACE ROUGHNESS 125
XXX +/- .005	

CONCENTRICITIES .010 (FIM)
INTERNAL RADII .015~.030
BREAK CORNERS .005~.015

TITLE			
TANK, ELLIPTICAL, JACKETED, 200L			
SIZE A	ISOF NO	DWG NO IFP-021-1822C	REV B
SCALE NA	WEIGHT N/A	SHEET 2 OF 2	