

RELEASE NOTES

Release notes IDEA StatiCa 25.0

Apr 23, 2025

Table of Contents

CONCRETE DESIGN

Modeling operations - Negative volume, Cutting plane and Cut
Cast-in plates

Anchoring reinforcement according to ACI

Environment and code-checks aligned with ACI

Prestressing per ACI 318-19

Australian code for Detail

Templates for ACI and AS

Import from Beam to Detail

Lateral torsional buckling - export to RCS

STEEL DESIGN

Connection Wizard

Combination of a parametric template and unrelated operations

Saving of user-defined cross-sections to MPRL

Slotted hole sizes for the selected plate

Load effects displayed in the scene

Improvements in report readability

Direct link from Connection to Viewer

Regional improvements in 25.0

Member wizard models available for AISC and AS

BIM AND CHECKBOT

BIM link between MIDAS CIVIL NX and IDEA StatiCa Checkbot

New REST API between Grasshopper and Connection

Supported BIM links in version 25.0

USABILITY AND LICENSING

New Launcher app

New style of applications in 25.0

Concrete block info in Viewer with reduced response time

User portal - Self-serviceability

Version 25.0 is focused on extending the scope of anchoring design, simplifying the connection initial design and evolving Checkbot app from data-exchange platform to designing tool.

Concrete Design

Modeling operations – Negative volume, Cutting plane and Cut

Complex anchoring schemes are now possible. As 3D in Detail evolves, the possibilities open up and we are able to cater for more complicated cases. IDEA StatiCa Detail features the ability to modify an anchor block using Negative Volumes, Cutting Planes, and Cut Operations.

Complex shapes of anchoring

Additional modeling operations enable the creation of more complex shapes and expand potential applications, including pedestals, non-rectangular anchor blocks, foundation strip extensions, and anchoring near openings. We are therefore moving towards a more general use of the application. However, it is important to note that the **application is only suitable for the anchoring cases** for which it is verified.

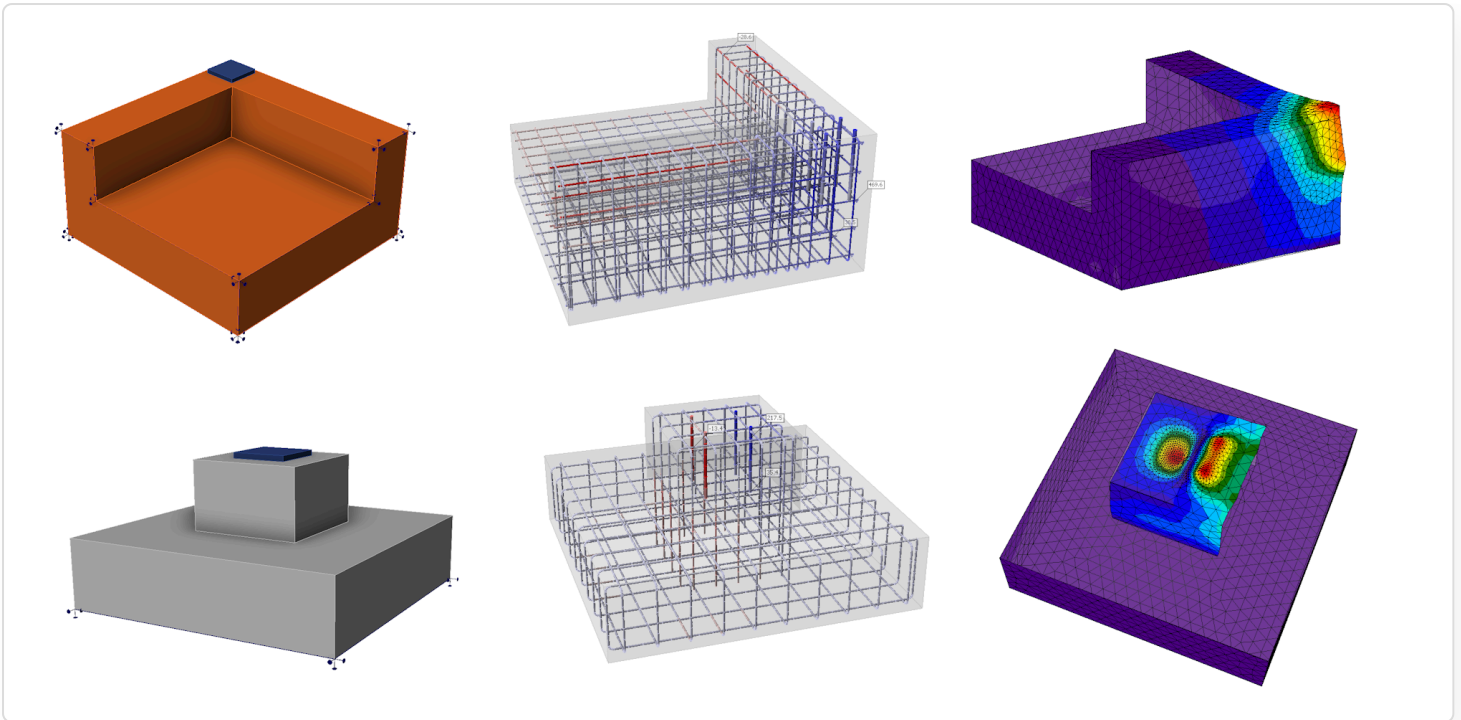

Further development and verifications are needed to assess punching and other more complex and general cases. These cases are not supported in version 25.0.

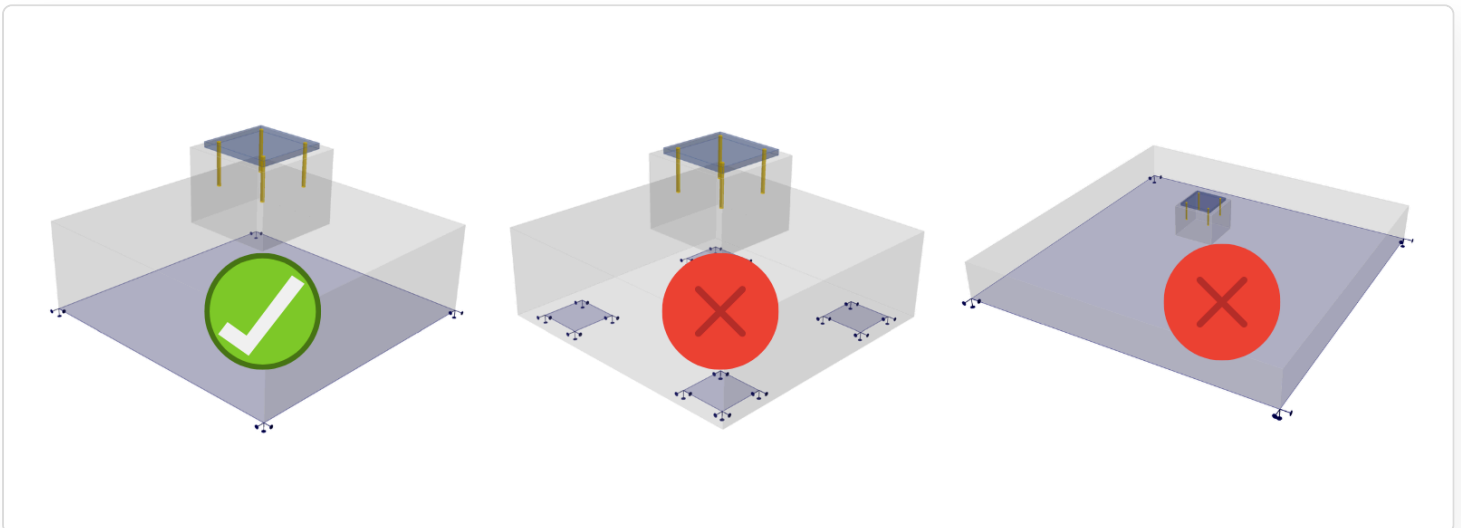

Note: In the case of surface support, failure always occurs at the anchorage area, and punching does not play a role. Only in cases of soils with low stiffness may punching occur, or also in the case of pile caps. For these situations, the software is not yet suitable for use.

Merging of anchor blocks

3D in Detail supports only one anchor block. However, since more blocks can be created in IDEA StatiCa Connection, it is now allowed to import these multiple blocks into the Detail, where they can be merged using the Cut operation and then reinforced. In the case of overlapping blocks, it is then necessary to delete one of the blocks and assign the base plates to the same block.

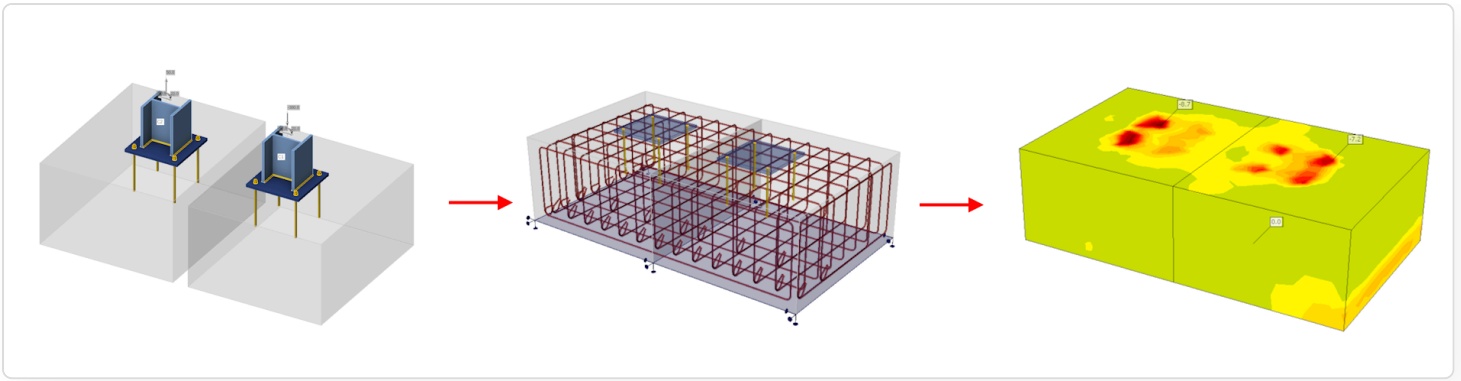

The Cut operation

The basic operation to adjust the block shape is the Cut operation. The Cut can be according to a negative volume or a cutting plane, these can be found under the "model entity" button.

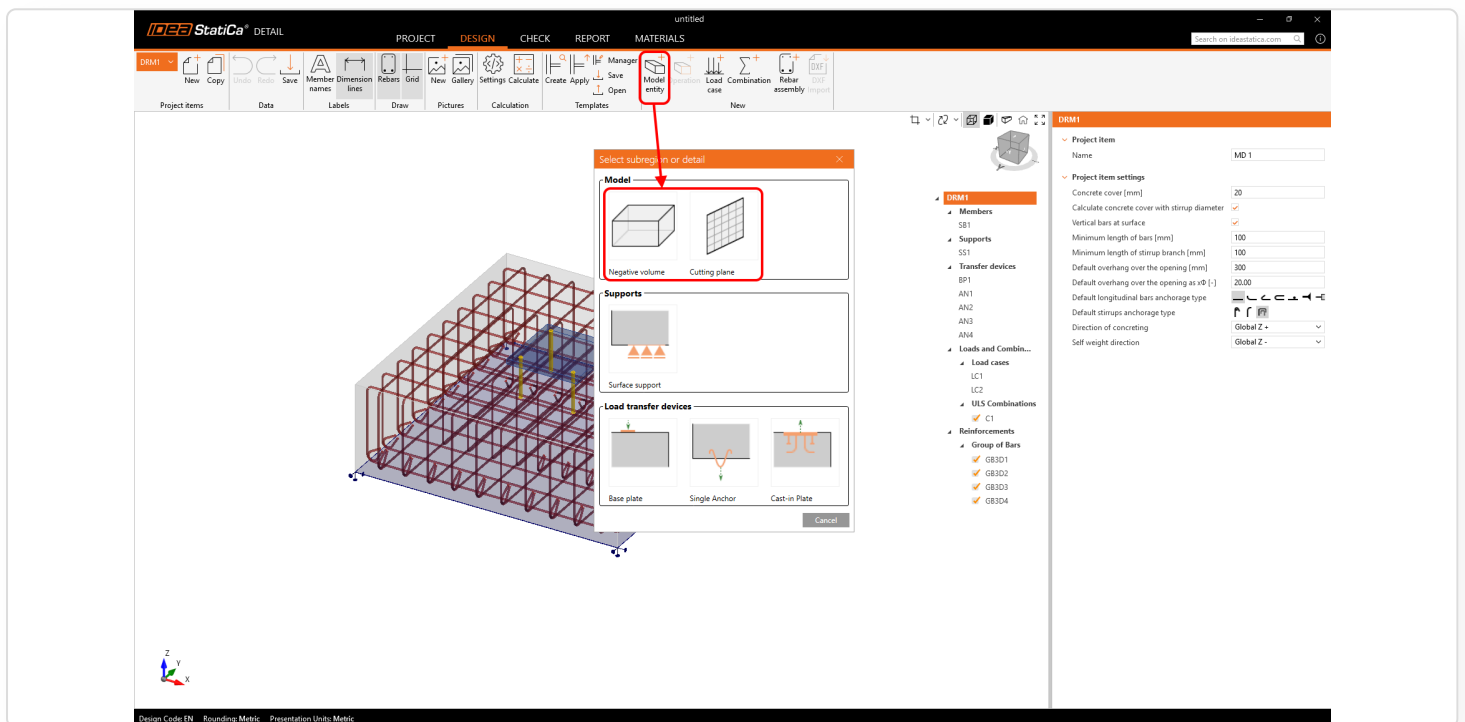

- The **Cut operation** is applied to the negative volume or cutting plane to adapt the host block by the operation.

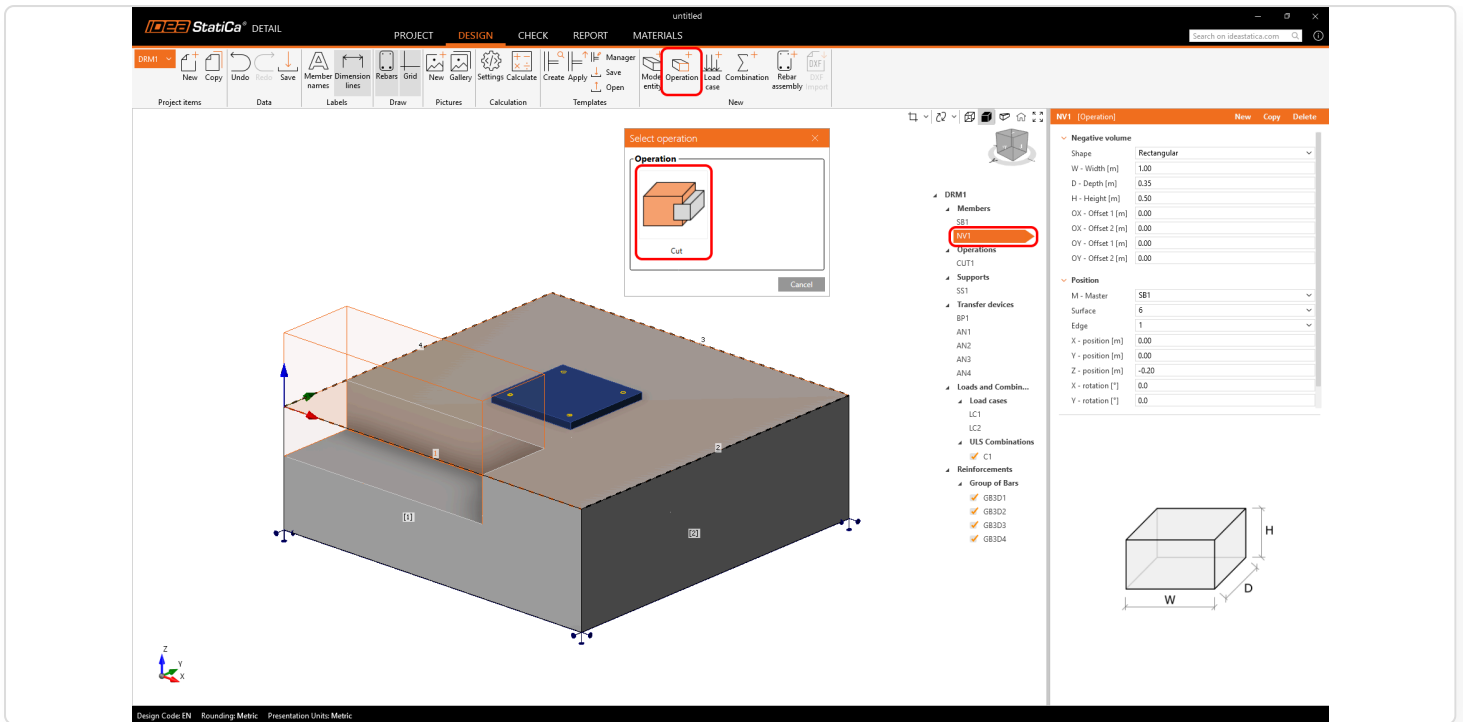

- A Cutting plane works in a similar way. As shown in the following figure, any cut generates new edges and surfaces that can serve as references for placing reinforcement.

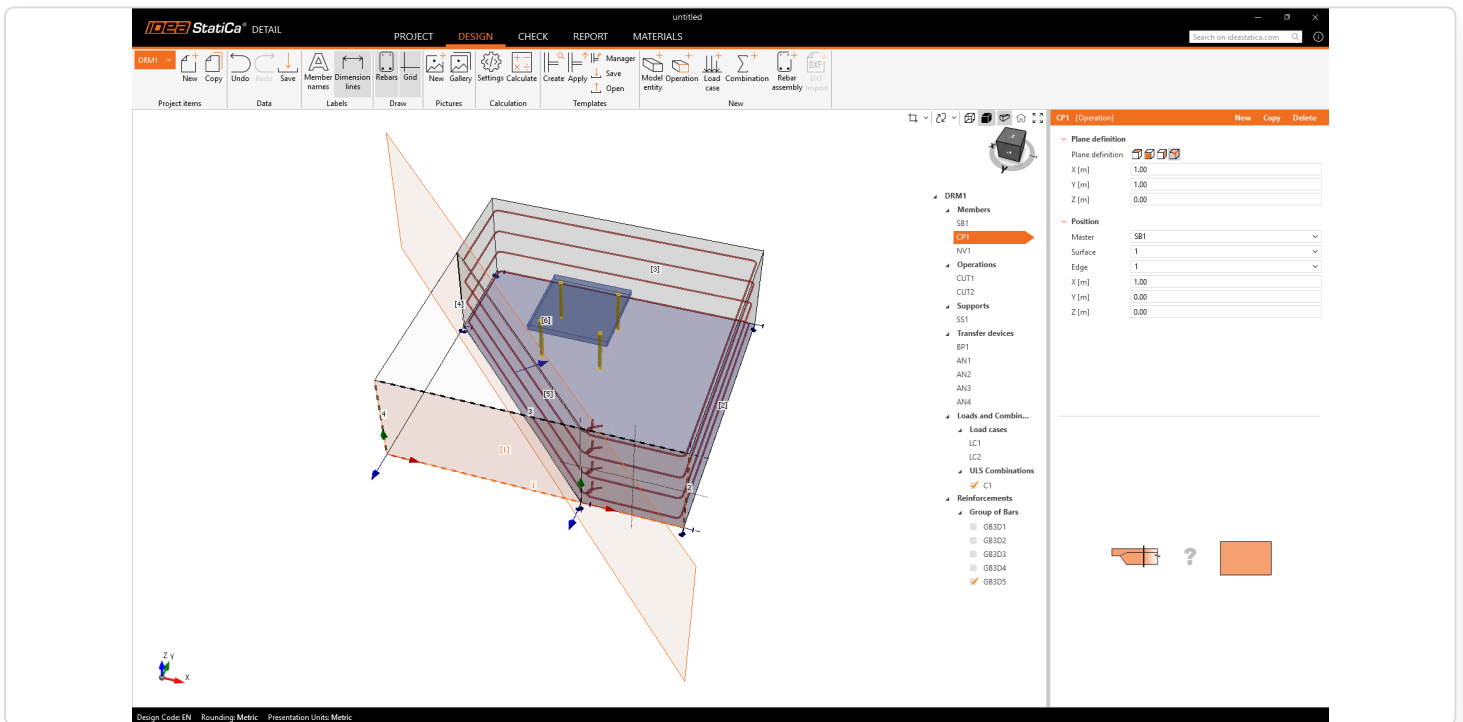

- After the first Cut operation is applied, reinforcement can be referenced to either the original or newly created faces and edges. This is controlled through a new setting in the property grid.

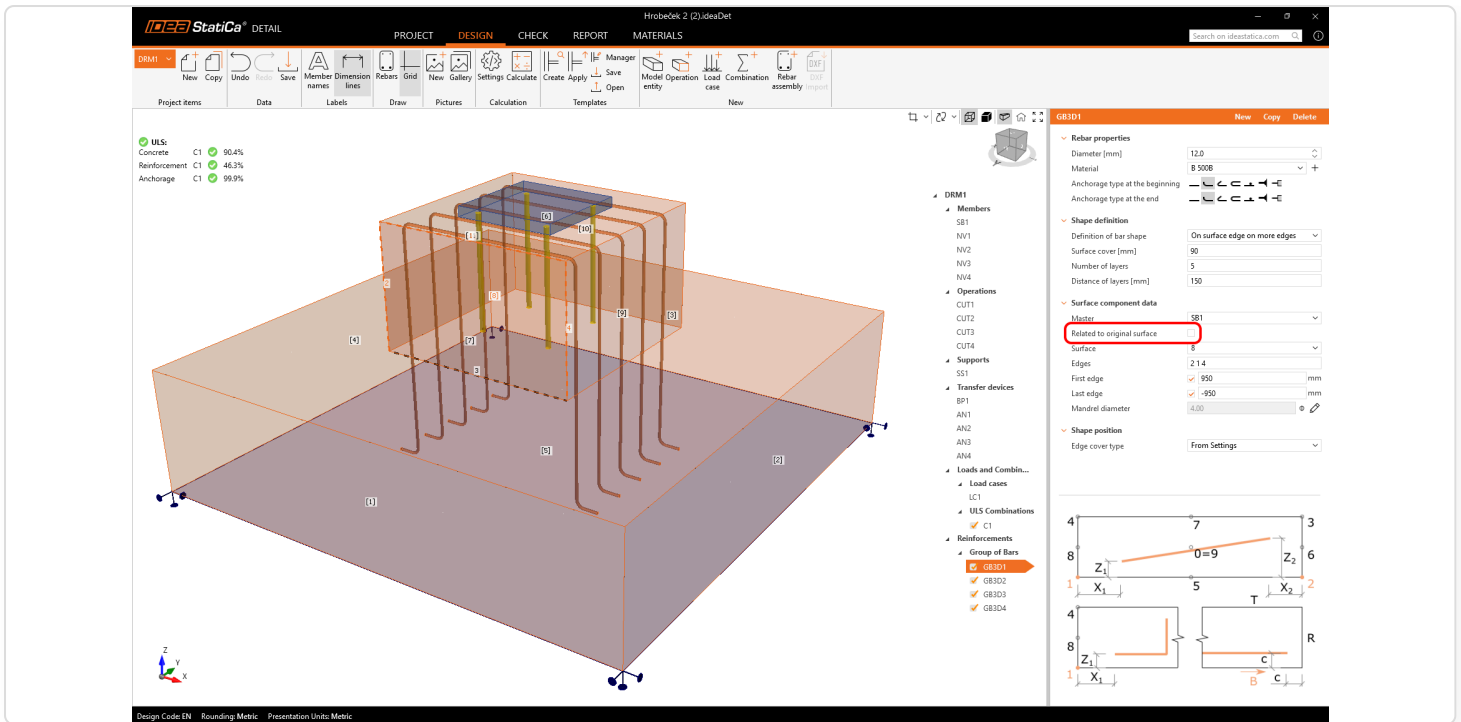

These new enhancements are available for EN and ACI standards.

Additional anchoring types definition

When implemented in IDEA StatiCa Detail, cast-in plates unlock more anchoring possibilities for reinforced concrete blocks, allowing engineers to design and analyze complex anchorage systems. This integration enables optimized designs and a more efficient workflow in reinforced concrete detailing.

In version 25.0, we are introducing **cast-in plates** with fasteners/reinforcement of several types commonly used in construction for securing beams, columns, or façade elements. Cast-in plates ensure strong and reliable load transfer between steel and concrete structures.

Cast-in plates in Detail

Cast-in plates are available as a **Load Transfer Device** in the model entity selection. The **plate's geometry and position** can be defined in a single property grid, while an additional table allows users to add and combine multiple **groups of fasteners**.

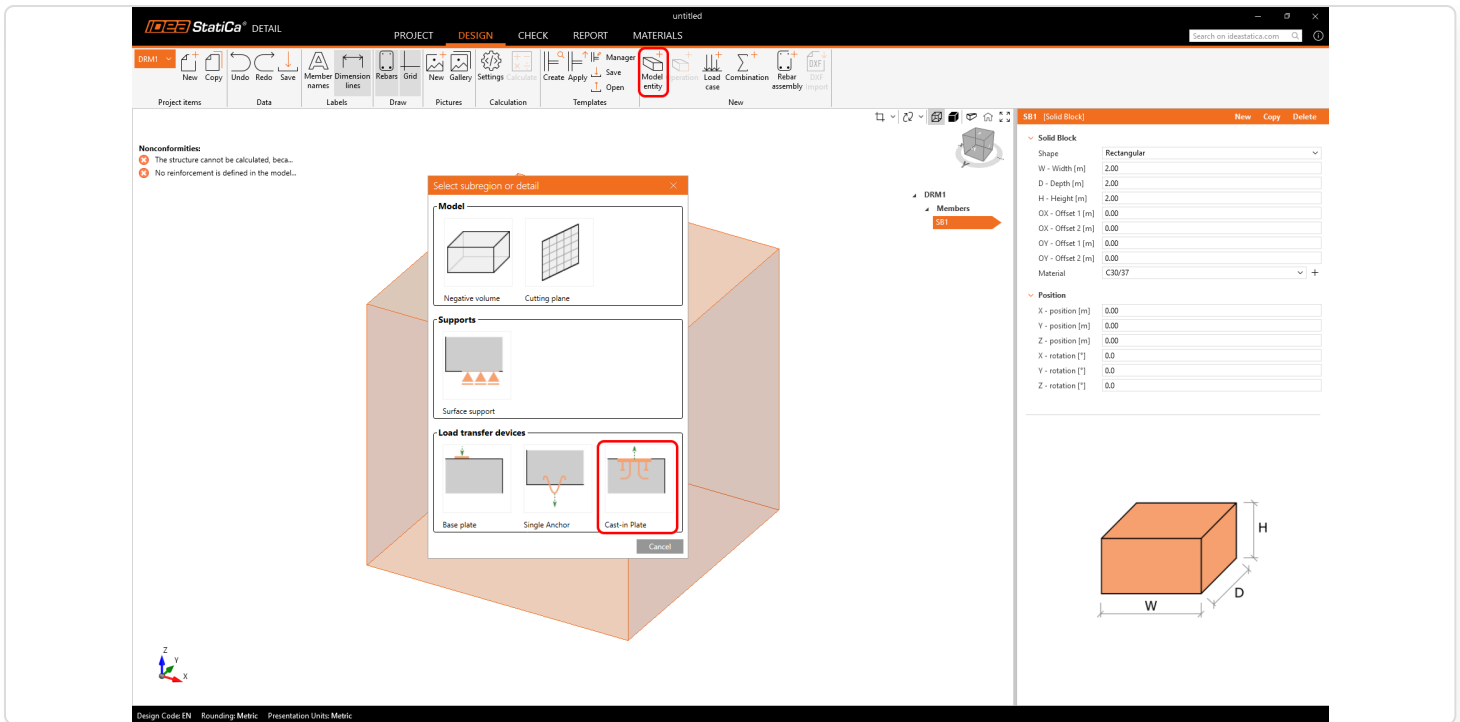

The **Cast-in plate** allows for welded reinforcement in three shapes: **Straight**, **L-shape**, and **U-shape**.

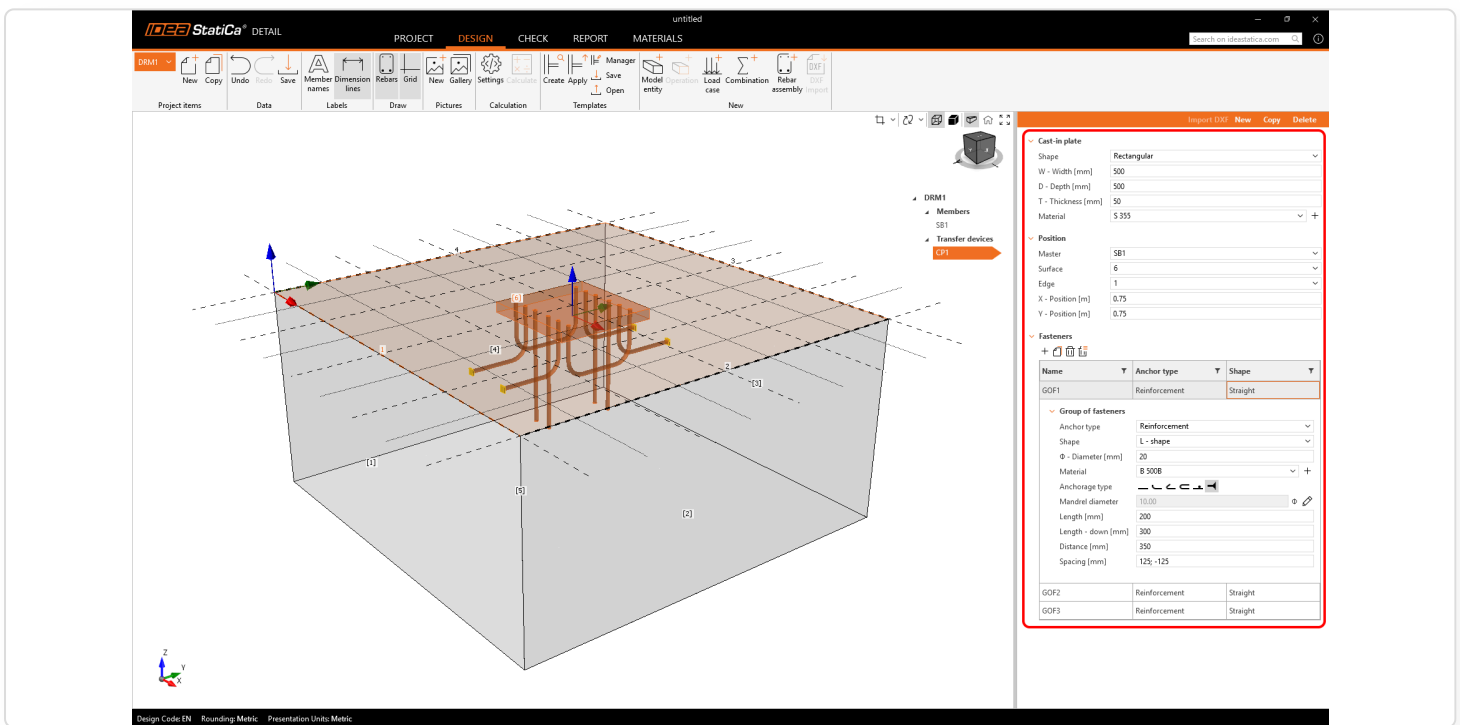

Reinforcement Types

Fasteners can be defined directly for each specific plate. Users can add an **unlimited number** of fasteners and even combine multiple types within a single plate.



- **Straight:** Anchors can be arranged in rows and positions following a predefined key (similar to bolt placement in Connections). Users can define material, length, and diameter, as well as specify an anchorage type.

Group of fasteners

Anchor type	Reinforcement
Shape	Straight
Φ - Diameter [mm]	20
Material	B 500B
Anchorage type	
Length [mm]	500
Rows [mm]	175; -175
Position [mm]	50; -50

- **L-shape:** Defined as two rows of anchors with adjustable spacing and row distance, with the option to specify anchorage type.

Group of fasteners

Anchor type	Reinforcement
Shape	L - shape
Φ - Diameter [mm]	20
Material	B 500B
Anchorage type	
Mandrel diameter	10.00 
Length [mm]	200
Length - down [mm]	300
Distance [mm]	350
Spacing [mm]	125; -125

- **U-shape:** A continuous series of reinforcements forming a U-shape, connected on both sides.

Group of fasteners

Anchor type	Reinforcement	▼
Shape	U - shape	▼
Φ - Diameter [mm]	20	
Material	B 500B	▼ +
Mandrel diameter	10.00	Φ ✎
Length [mm]	200	
Distance [mm]	350	
Spacing [mm]	200; -200	

Model Behavior

Anchors are treated as elements resisting both **shear and tension**, as they are welded to the plate. Their evaluation follows the same principles as standard anchors, with similar limitations (e.g., shear in the anchor cannot yet be assessed in the application). For more information, see the [Theoretical Background](#).

Anchoring reinforcement according ACI

IDEA StatiCa is a tool for solving complex 3D tasks and is fully verified for anchoring in concrete. This solution allows you to perform designs without oversimplifications and provides checks based on the Ultimate Limit State (ULS).

Together with IDEA StatiCa Connection for anchorage verification, Detail provides a comprehensive solution for everyone dealing with steel-to-concrete connections. In **Connection**, you can evaluate anchors in a plain concrete block, while in **Detail**, it is possible to assess the impact of additional reinforcement.

This workflow is already proven by users in real practice who use Eurocode, for whom it has been possible to solve 3D tasks since version 24.1. See the release note: [Detail out of beta](#).

IDEA StatiCa Detail

IDEA StatiCa Detail is now fully integrated with the ACI standard, **now including 3D in Detail**. The environment supports both imperial and metric units, and assessments are conducted in full compliance with the ACI standard.

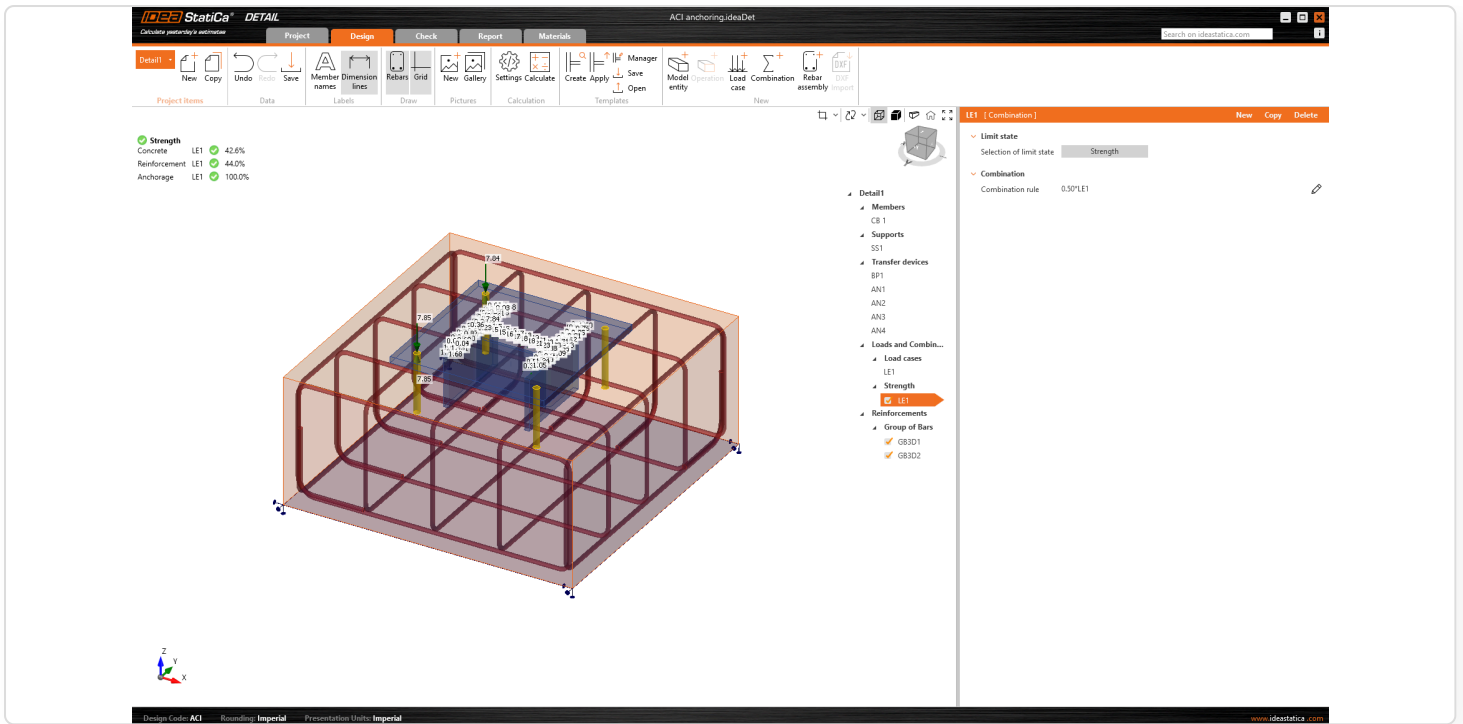

Models can be created either from scratch or using predefined templates directly within the application.

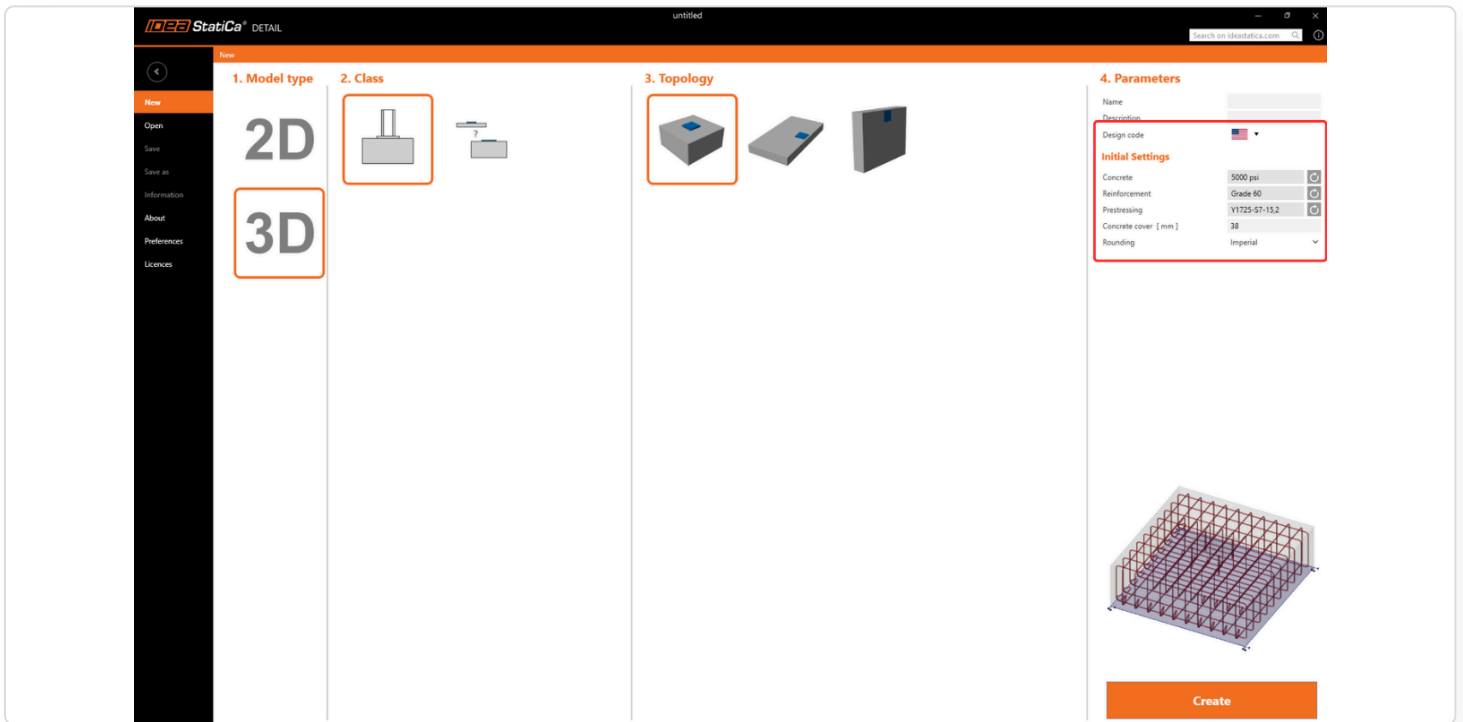

For non-conforming anchorage evaluations based on ACI formulas for plain concrete, the model can be exported from IDEA StatiCa Connection. The export includes loads, anchor parameters, and basic dimensions. Only the reinforcement needs to be added. More about the import can be found in the article: [Import of Anchoring from Connection to Detail](#).

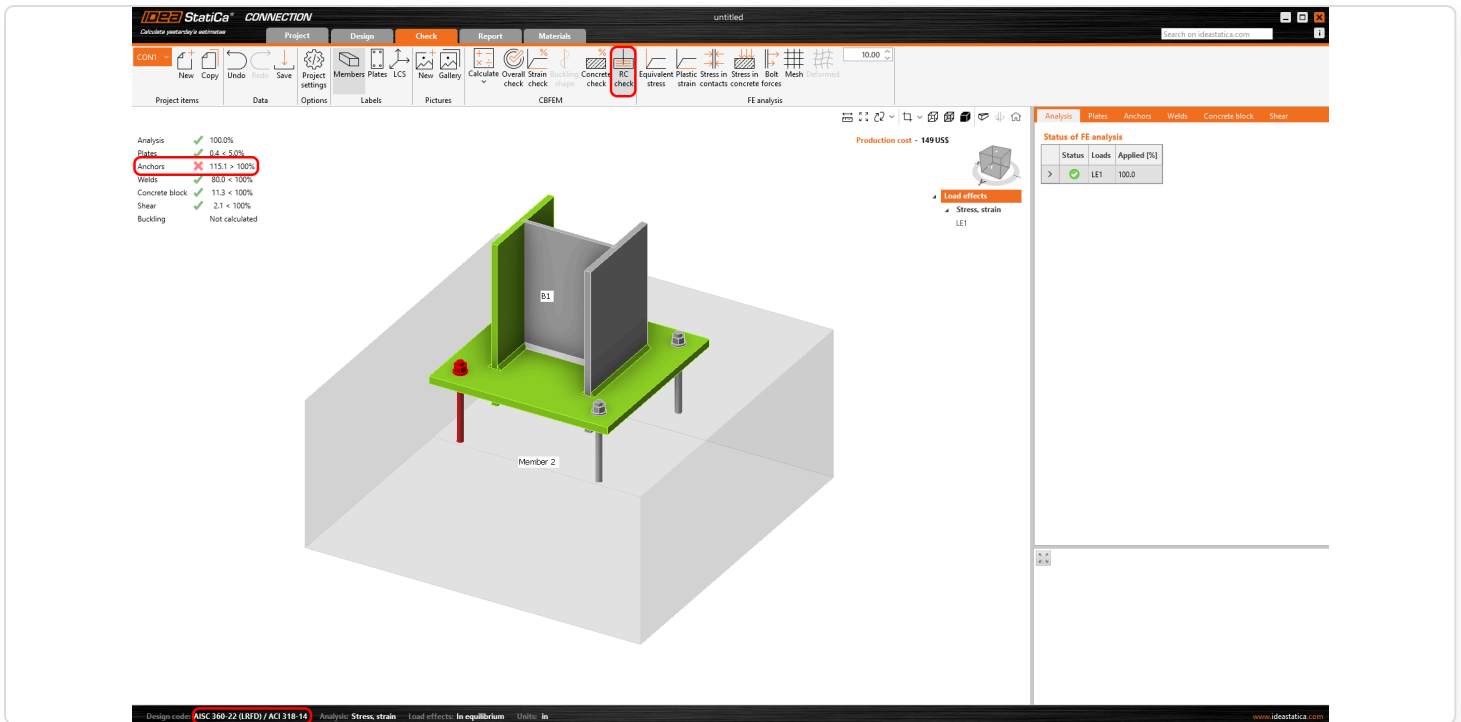

The results are presented in accordance with ACI standards, incorporating proper nomenclature, strength reduction factors, and relevant design provisions. Described in more detail in the [Theoretical Background](#) in chapter dedicated to ACI.

Known limitations for 3D in Detail

Since Detail is just a tool and cannot replace engineering judgment, a safe understanding of its functions, benefits, and limitations is necessary. Read the limitations that must be taken into account:

- The solution is suitable only **for reinforced concrete**.
- **Verified only for anchoring**.
- The application provides **ULS checks**.
- **Only one concrete block** is supported in Detail.
- In Detail, the anchors are only checked for tensile strength. It is necessary to **use Connection for shear and interaction checks**.
- Only models **anchored via the base plate** and **only Direct contact** can be imported to Detail (from Connection).
- **Imported loads and user-input loads cannot be combined within one model**.

For a full list of limitations with further explanation, see the article: [Known Limitations for 3D Detail](#)

Environment and code-checks aligned with ACI

The Detail terminology and code-checks now align with ACI 318-19. Key changes include enhanced deflection and crack width assessments, updated concrete strength calculations, and improved UX for ACI users.

Terminology and Code-checks align with ACI

Modifications include adjusted default coefficients, a revised serviceability design approach, and a clearer distinction between long- and short-term checks. The methodology for creep and the stress-strain diagram now accounts for long-term serviceability loads. More details below:

- **α_1 coefficient for calculation of concrete limit strength**

ACI 318-19 uses a parabolic stress-strain diagram with a decreasing plastic branch for concrete, while Detail applies a diagram with a horizontal plastic branch. To align with ACI 318-19, the concrete's limit strength can be adjusted using the α_1 factor, resulting in a parabola-rectangle stress-strain diagram. This coefficient is set in Project settings, either by code or as user input. When defined by code, its value follows ACI 318-19 Section 22.2. The concrete strength is then calculated as: $f_{c,lim} = \alpha_1 * \Phi_c * \eta_{fc} * k_{c2} * f_c'$

- **Change default strength reduction factor values**

Most models in Detail are expected to be shear-controlled or involve corbels and brackets. Therefore, the default coefficients have been set to 0.75 per ACI 318-19 Table 21.2.1. For tension-controlled models, users can adjust the coefficients as needed based on the table.

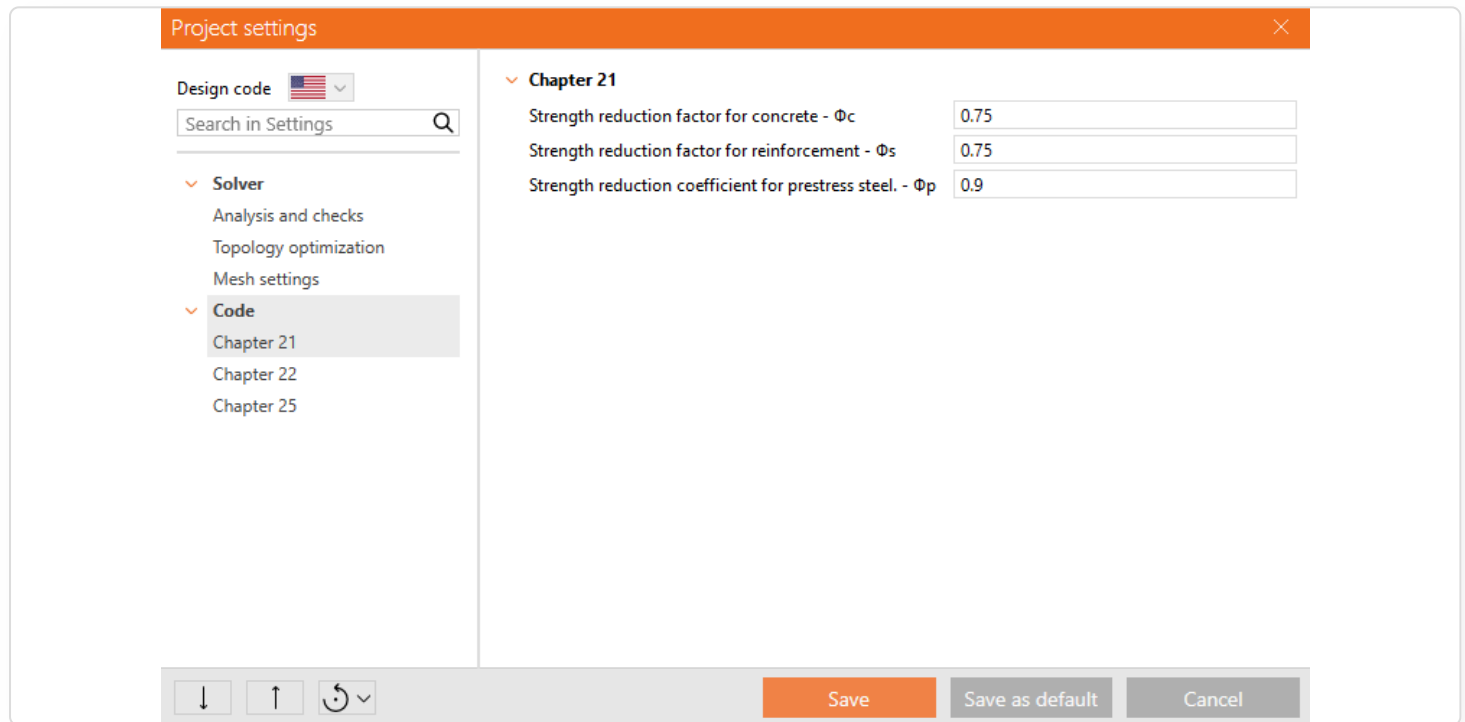

- **Serviceability checks**

Serviceability combinations are divided into short-term and long-term types. Users can enable or disable deflection and crack width assessments for each. For long-term combinations, the sustained load duration in months must be specified. Short-term combinations exclude creep effects, while long-term combinations calculate the time-dependent factor ξ from ACI 318-19 Table 24.2.4.1.3 based on sustained load duration. The creep coefficient is taken from the concrete properties in the Materials tab. To account for long-term behavior, the modulus of elasticity E_c is adjusted using ξ , resulting in the effective modulus $E_{c,eff}$.

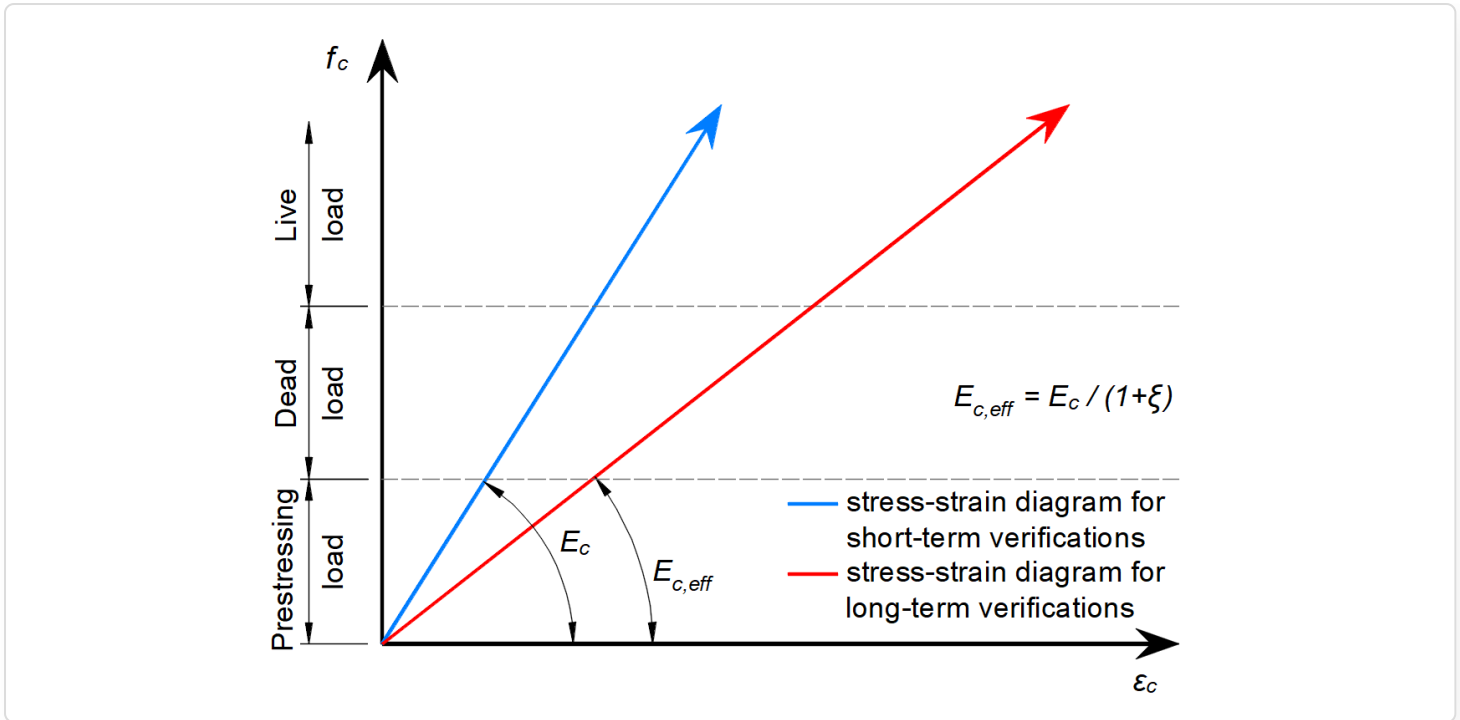

• Deflection check

Deflections are calculated for each combination selected in the Design tab. However, checks are performed only if enabled using the Long-term and Short-term buttons in the top ribbon, with limits set according to ACI 318-19 Section 24.2. Time-dependent deflections are assessed for long-term combinations based on these limits. Users can also view deflections separately for Dead Load and Live Load or see the total deflection (DL + LL). Load type selection is available in the Design tab for each load case.

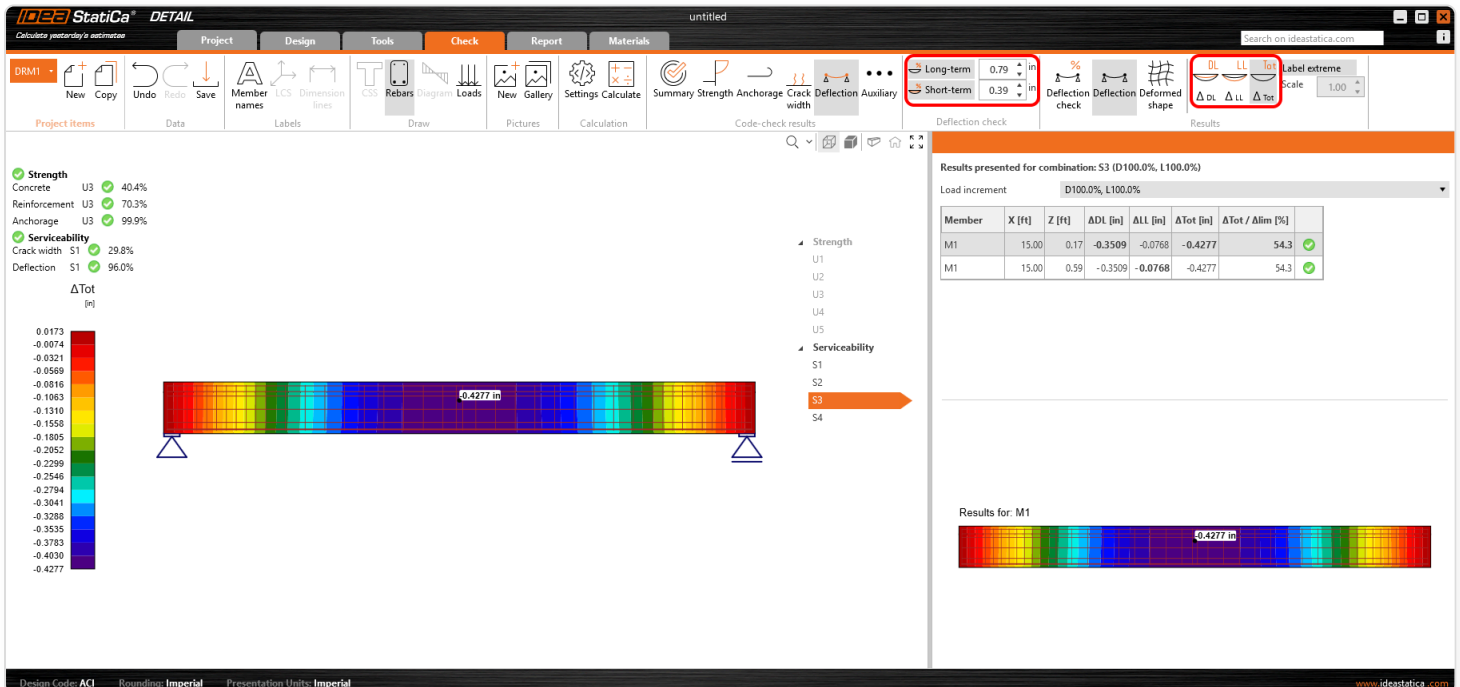

• Crack width check

Crack width assessment follows the same rules as deflection checks. Time-dependent cracks are evaluated using long-term combinations, following the same selection process.

• Documentation

The chapter **Structural Verifications According to ACI 318-19** has been added to the **Theoretical Background**.

Environment and Interface improvement

The UX and terminology in Detail have been adjusted for ACI users in both Imperial and Metric units, improving navigation for model, load, and reinforcement input. Results are clearer, and reports now include explanations with valid ACI references. Terminology has been adapted from Eurocode-based labels to ACI-specific naming for better clarity. More details below:

- **Extended options for inputting reinforcement diameters**

A double option for entering reinforcement diameter is now available for all reinforcement types, either by ASTM A955 standards or as user input based on the display unit settings.

The image displays two panels of the software interface, each showing the 'Rebar properties' section. In the top panel, the 'Definition of diameter' dropdown is set to 'ASTM A955', and the 'Φ - Diameter' field shows '#4'. In the bottom panel, the 'Definition of diameter' dropdown is set to 'User input', and the 'Φ - Diameter [in]' field shows '0.50'. Both panels also show 'Grade 60' for the material and icons for anchorage types at the beginning and end.

- **Combination renaming**

The combinations are labelled as Strength and Serviceability, with Serviceability further divided into long-term and short-term. Users can choose whether to assess deflections and crack widths for each combination.

- **Strength check nomenclature**

The strength assessments have been named in terms of variable titles and descriptions to be consistent with the ACI standard.

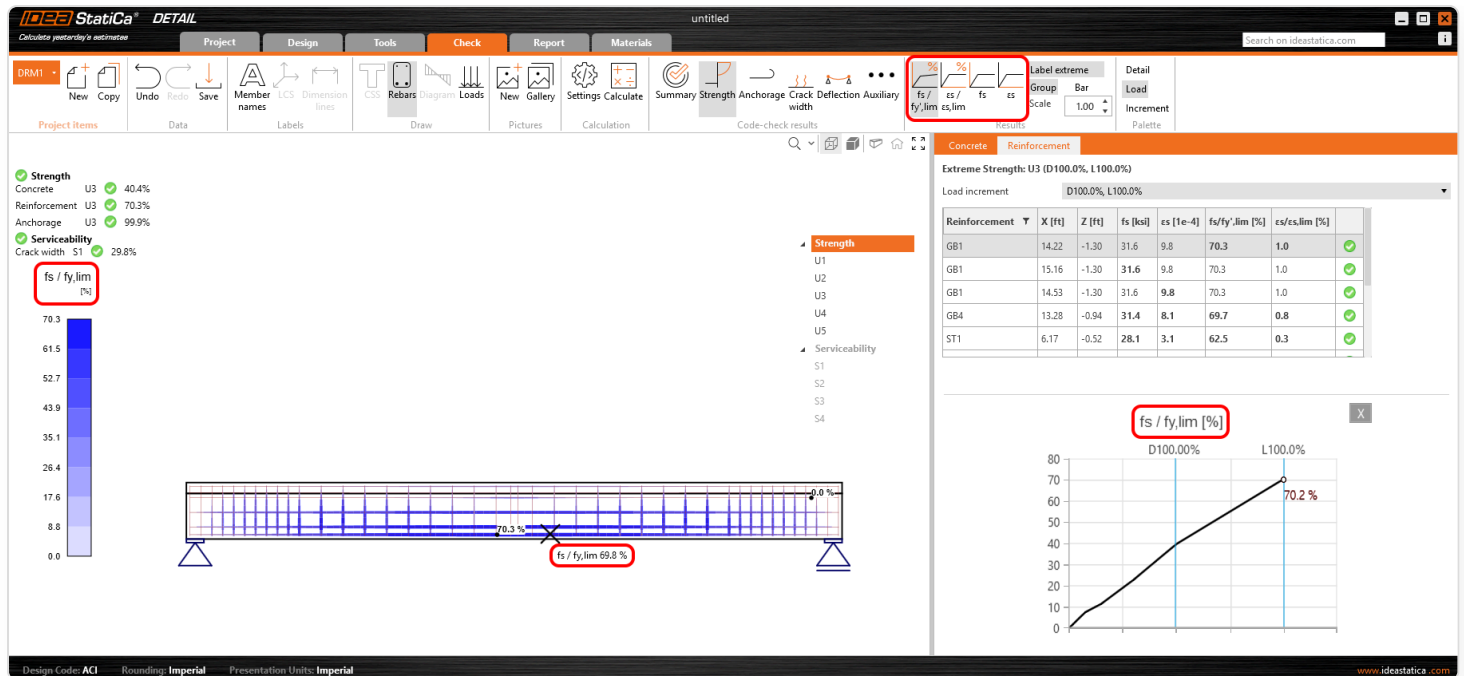

- **Deflection check nomenclature**

For deflection assessments, the variables have been named according to the ACI standard and relevant tooltips have been added.

- **Stress-strain diagrams in the Materials tab**

On the Materials page, the graphs and the naming of the variables have been designed according to the ACI standard.

- **Report adjustments**

All of the mentioned modifications are reflected in the automatically generated report, where, as shown in the picture, you'll see the introduction of the time-dependent factor for sustained load and the specification of sustained load duration to account for creep in the structure.

Prestressing to ACI 318-19 in Detail

Detail for ACI code supports the design of prestressed elements, including precast beams, deep beams, and girders. It also supports retrofitting of existing structures such as corbels, brackets, etc., for example, with prestressing bars.

Features include input for pre- and post-tensioned tendons, a prestressing steel database, and comprehensive ACI checks. The application includes a database of prestressing steels, the ability to input and evaluate **partially loaded areas**, and all required ACI standard checks, including **stress limitations** and **decompression checks**.

Key terms

This article covers the basic definitions. More details can be found in the new chapter of the theoretical background dedicated to prestressing according to ACI.

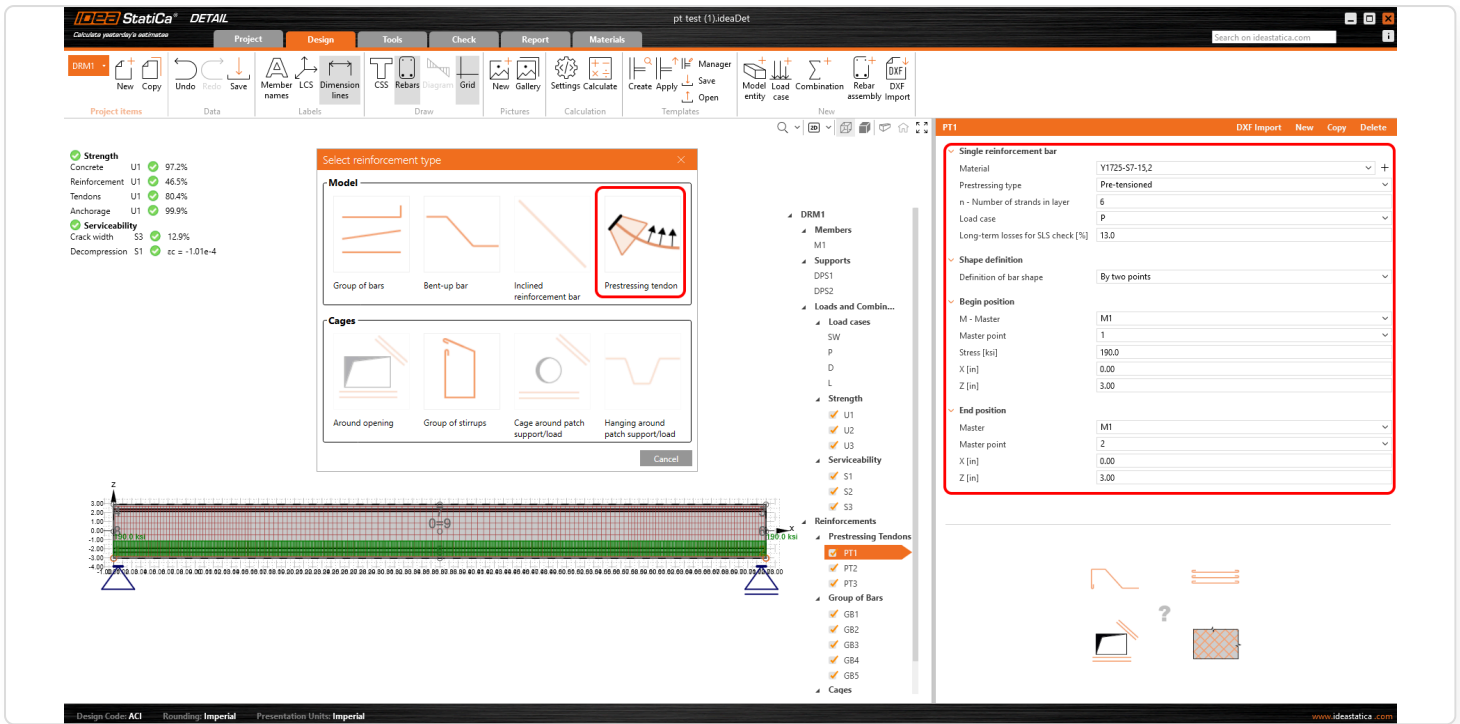

• **Prestressing load case type**

For the ACI standard, a Load Case type, Prestressing, has been added, allowing input of prestressing reinforcement. This Load Case type is required for defining the cable.

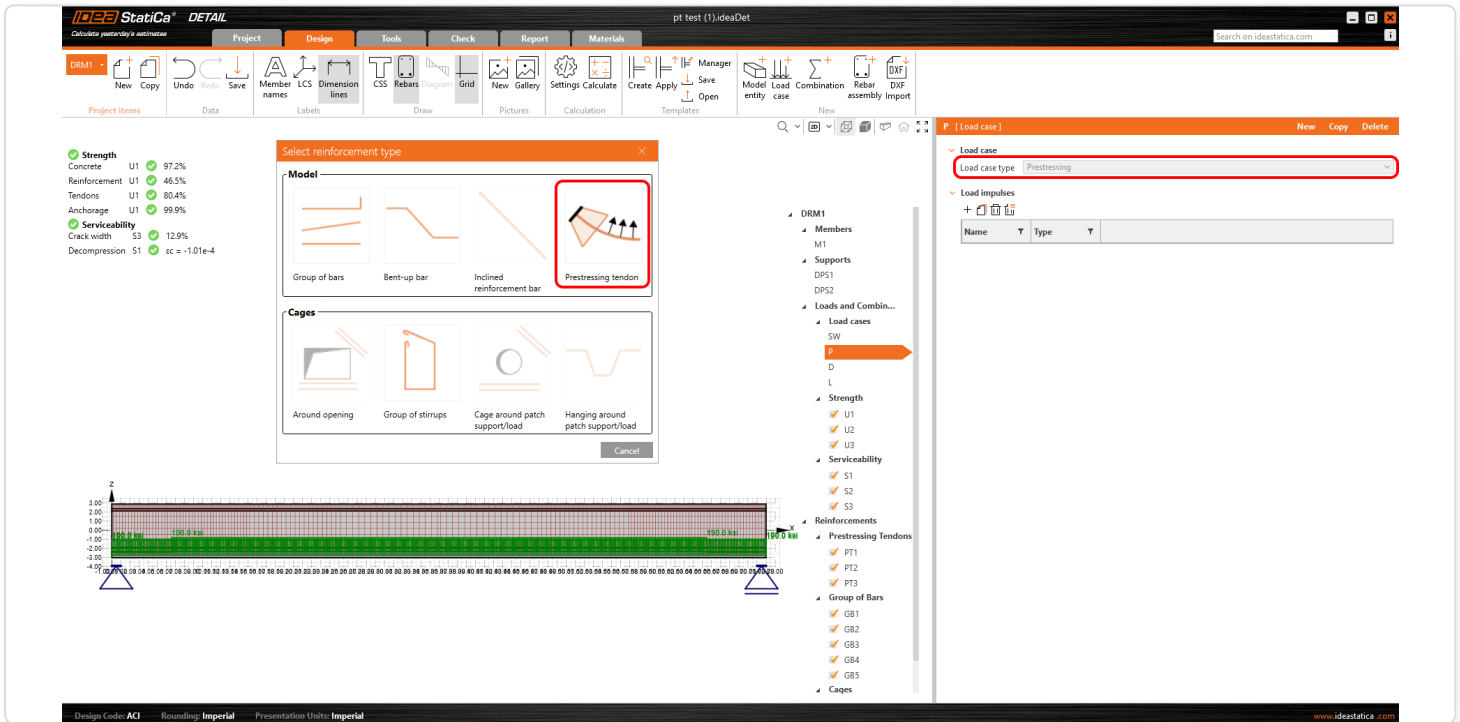

• **Pre-tensioned strands**

The layer of pre-tensioned strands for walls and beams can be defined using the coordinates of two points referenced to the master point. To determine the cable prestressing intensity, the stress in the prestressing reinforcement just before release from the abutments, after short-term losses such as anchorage set, abutment deformation, and short-term relaxation, must be specified.

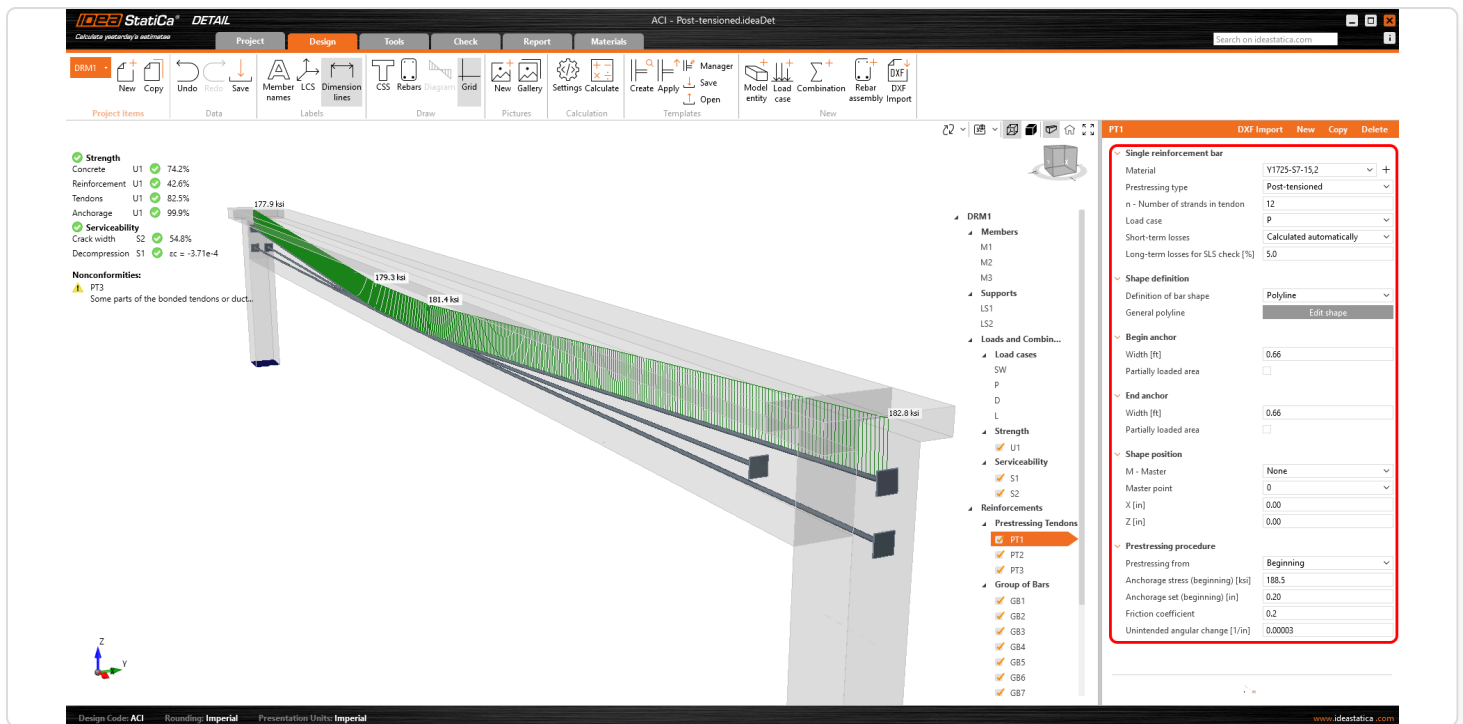

For long-term service combinations, an estimate of long-term losses due to shrinkage and relaxation must be provided as a percentage.

As outlined in the Theoretical Background, the loss due to immediate elastic concrete strain in pre-tensioned strands is calculated automatically and directly depends on the time-dependent factor for sustained load, ξ .

- **Post-tensioned tendons**

A post-tensioned tendon, with a customizable number of strands, can be defined using either two points like a prestressed cable or a polyline. The anchorage stress determines the prestressing intensity. Short-term losses are calculated automatically based on the tendon geometry and inputs from the prestressing procedure. For serviceability, long-term losses due to creep, shrinkage, and relaxation must be estimated as a percentage.

- **Partially loaded area**

For post-tensioned anchors, bearings, and point loads, the Partially Loaded Areas feature can be used to simulate increased concrete strength per ACI 318-19 (Chapters 22.8 and 25.9).

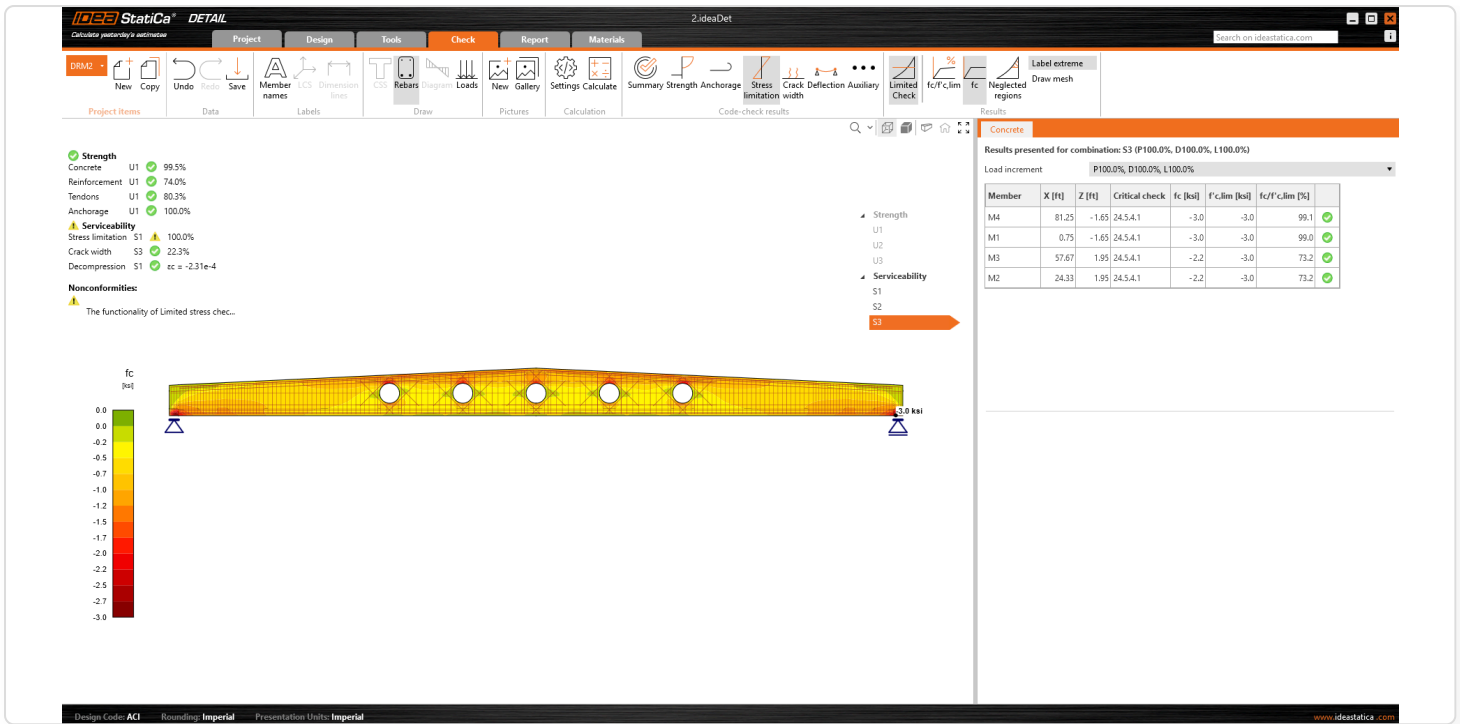

• **Stress limitation in Serviceability for prestressed members**

The application includes stress limitation checks for concrete in prestressed elements. Users start by selecting the prestressed flexural member class. For Classes U and T, serviceability stress limitations are verified per ACI 318-19 Section 24.5.4.1.

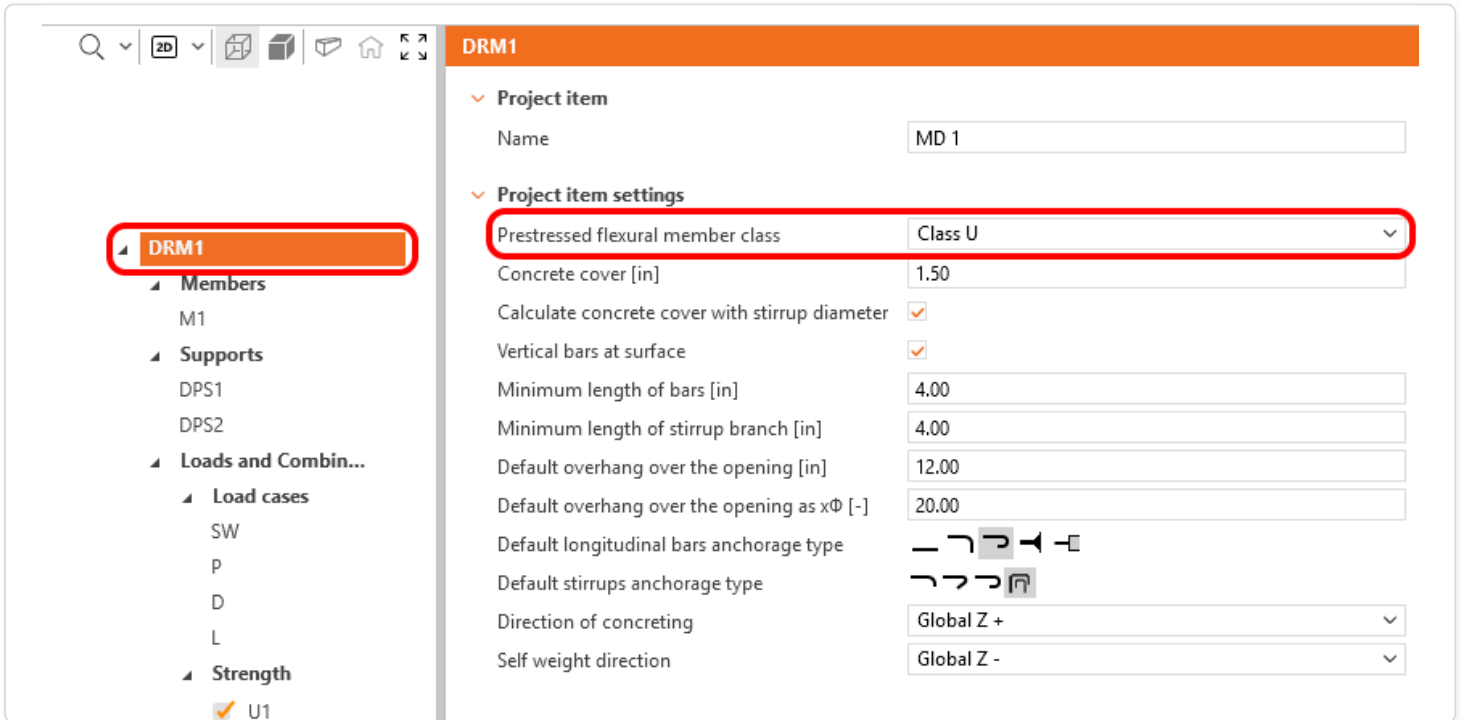

Reduction coefficients can be switched in Preferences.

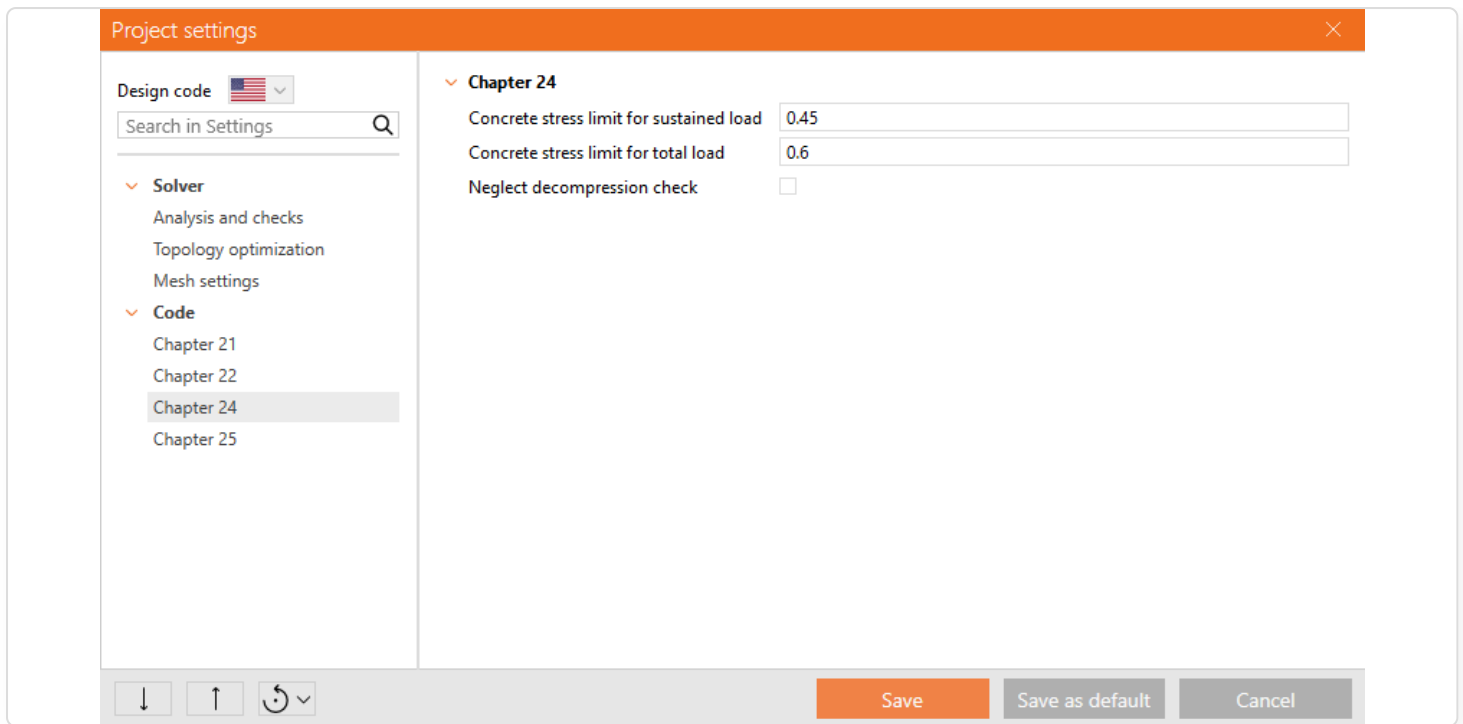

Australian code for Detail

Australian engineers can take advantage of the implementation of Australian Standard AS 3600 (2018) in the Detail application for 2D reinforced concrete models.

This integration ensures that engineers working with AS 3600 have an option to design discontinuity regions using CSFM. CSFM (**Continuous Stress Field Method**) is an innovative approach that allows engineers to move away from rough estimations and solve tasks using precise calculations. This provides Australian engineers with a modern alternative to the outdated Strut and Tie method, allowing them to efficiently design and assess **walls and beams with openings, pile caps (in 2D), pier caps, diaphragms, and other discontinuity regions** in concrete structures.

Learn more about the method implemented in IDEA StatiCa Detail and its practical applications in the article: [CSFM explained](#).

Users can utilize the **full functionality of Detail (in 2D)**, adapted to **AS 3600 terminology, material properties, and verification checks**. The user interface aligns with Australian standards, making the design process more intuitive and ensuring that calculations follow local industry requirements.

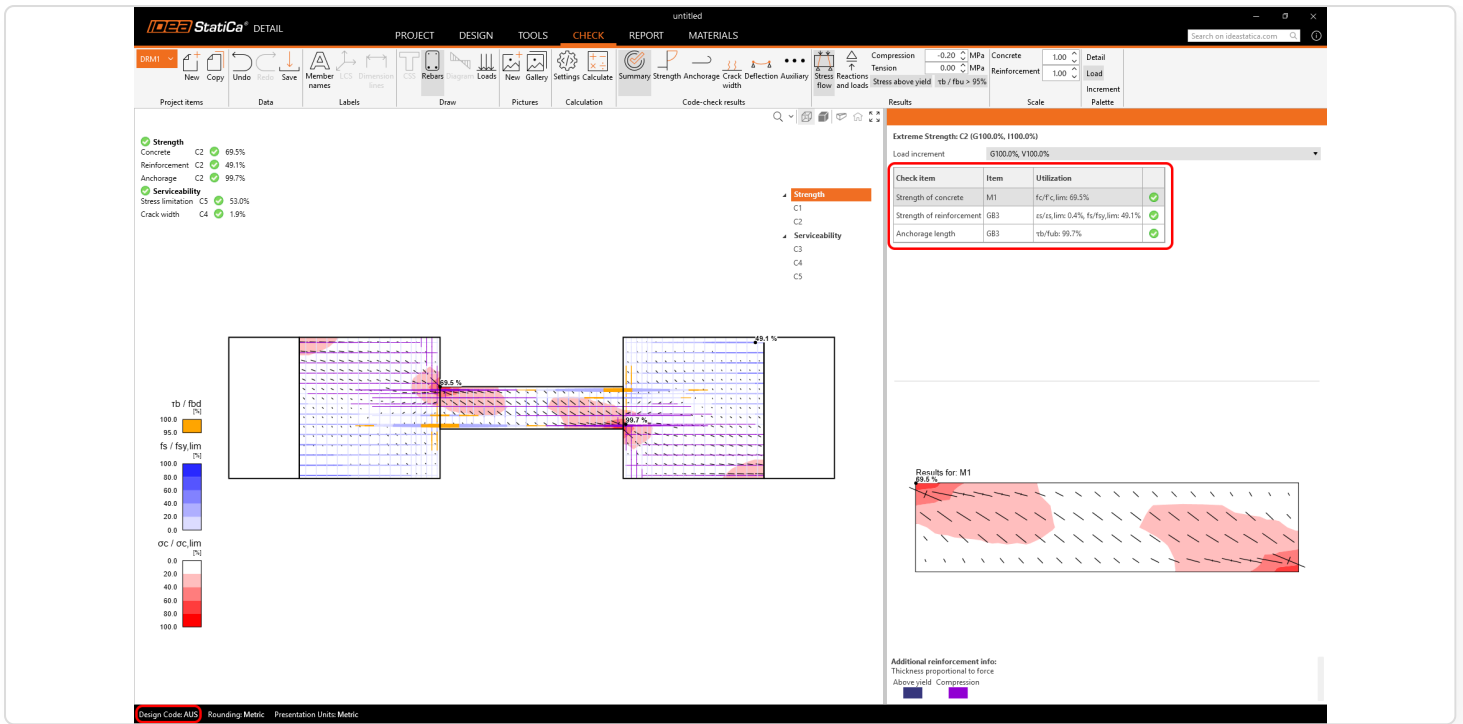

Key Features

- **Material Database** – A built-in database includes concrete, reinforcement, and steel materials defined by AS 3600.

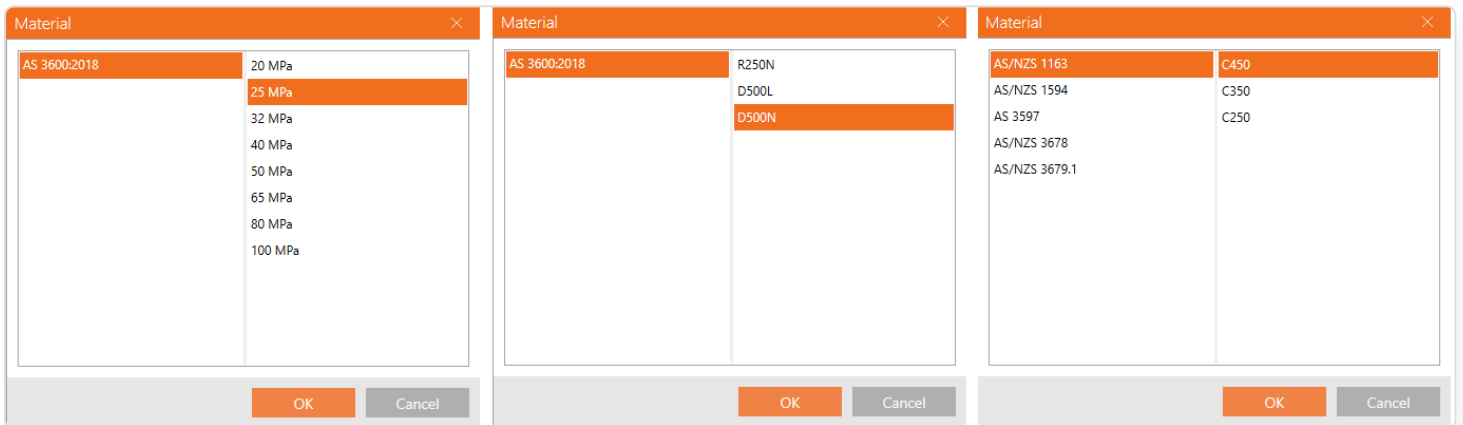

- **Standardized Nomenclature** – Variable names and labels throughout the application have been adjusted to match AS 3600, ensuring clarity in design and verification.

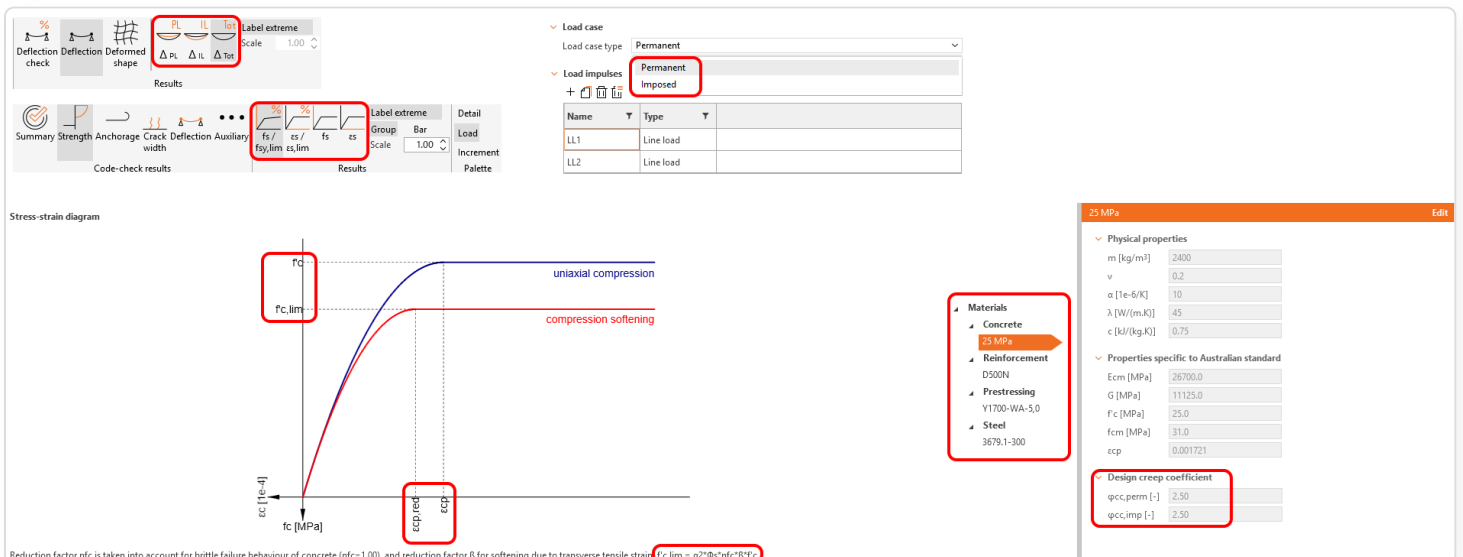

- **Refined Calculations** – Adjustments have been made to calculations, including:
 - 1 **Stress-strain diagrams** for serviceability and strength, incorporating **long-term effects using the design creep factor**.
 - 2 **Bond strength and B-factor** calculations for anchorage springs, ensuring compliance with AS 3600.

Templates in Detail for ACI and AS

Support for ACI with Imperial unit templates include walking columns, deep beams, and prestressed beams. For the Australian Standard, we provide metric-compliant templates for walls, beams, and bridges.

As part of our commitment to provide the application for engineers using the ACI standard, we include a set of templates in Imperial units. Currently, templates rounded to metric units are not available for ACI.

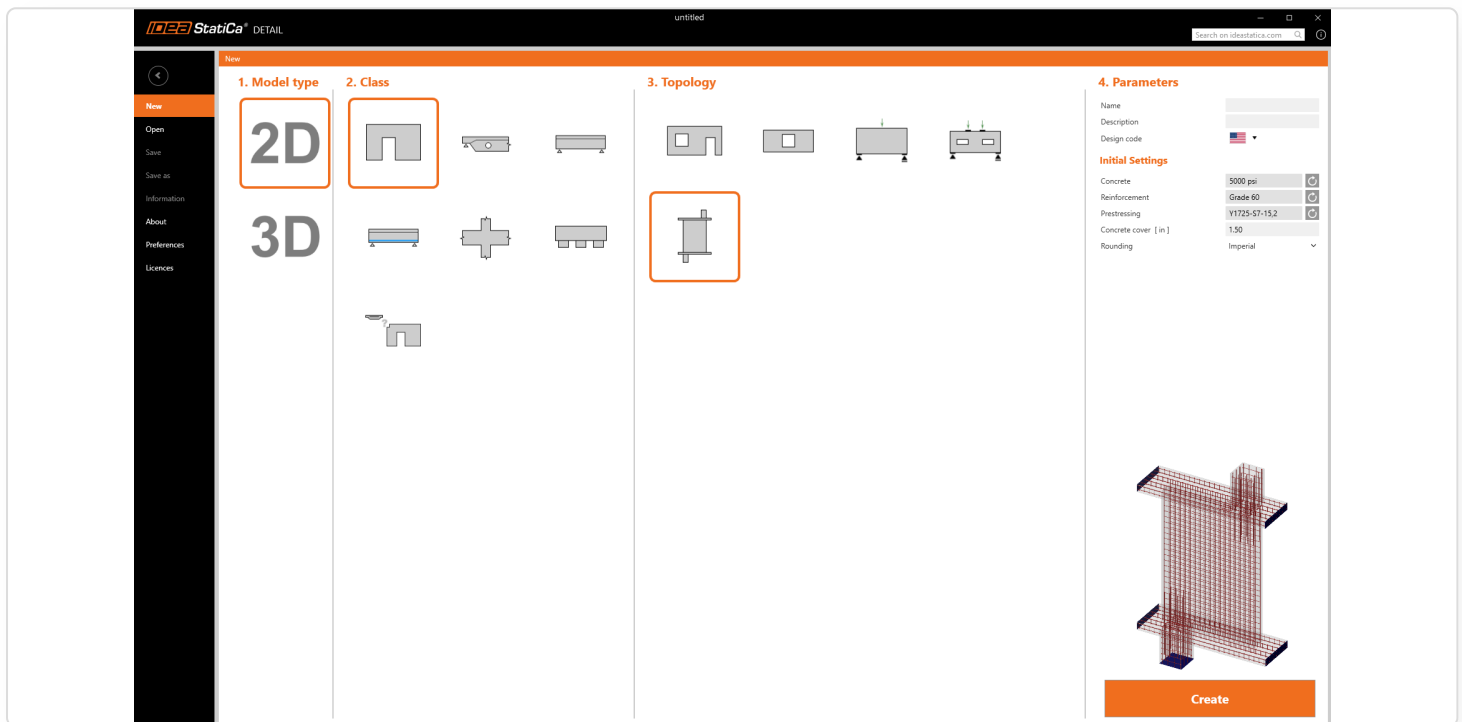

The existing classes include templates for walking columns, deep beams, deep beams with openings for walls, and coupling beams for beam cut-offs. Additionally, there are classes such as whole beams with a total of ten templates, a foundation class with three templates, and a prestressed beam class with five templates.

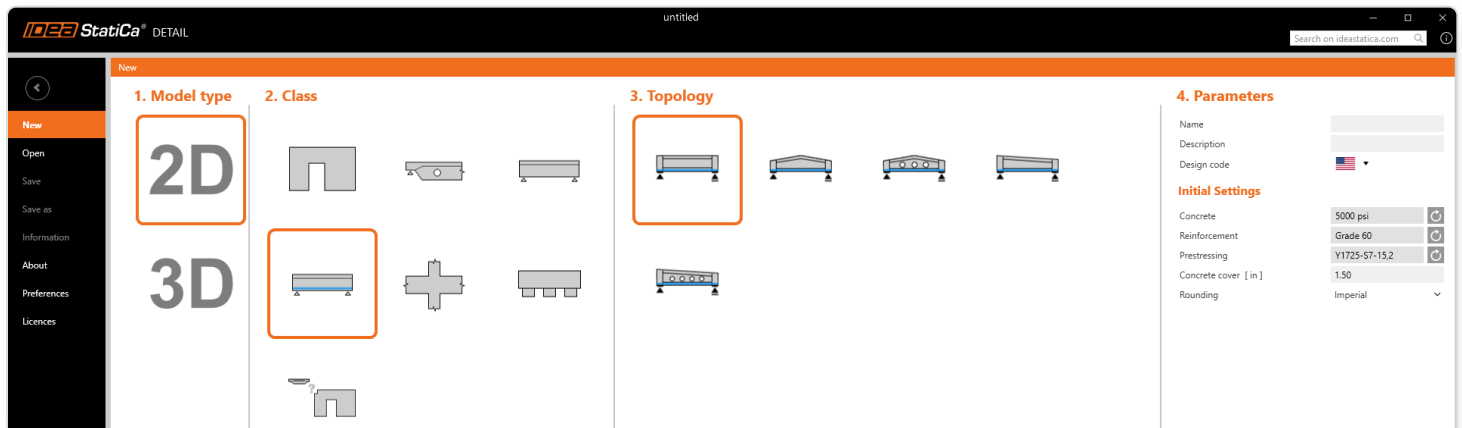

Additionally, as part of the implementation of the Australian Standard, we have provided a compliant set of standards rounded to metric units.

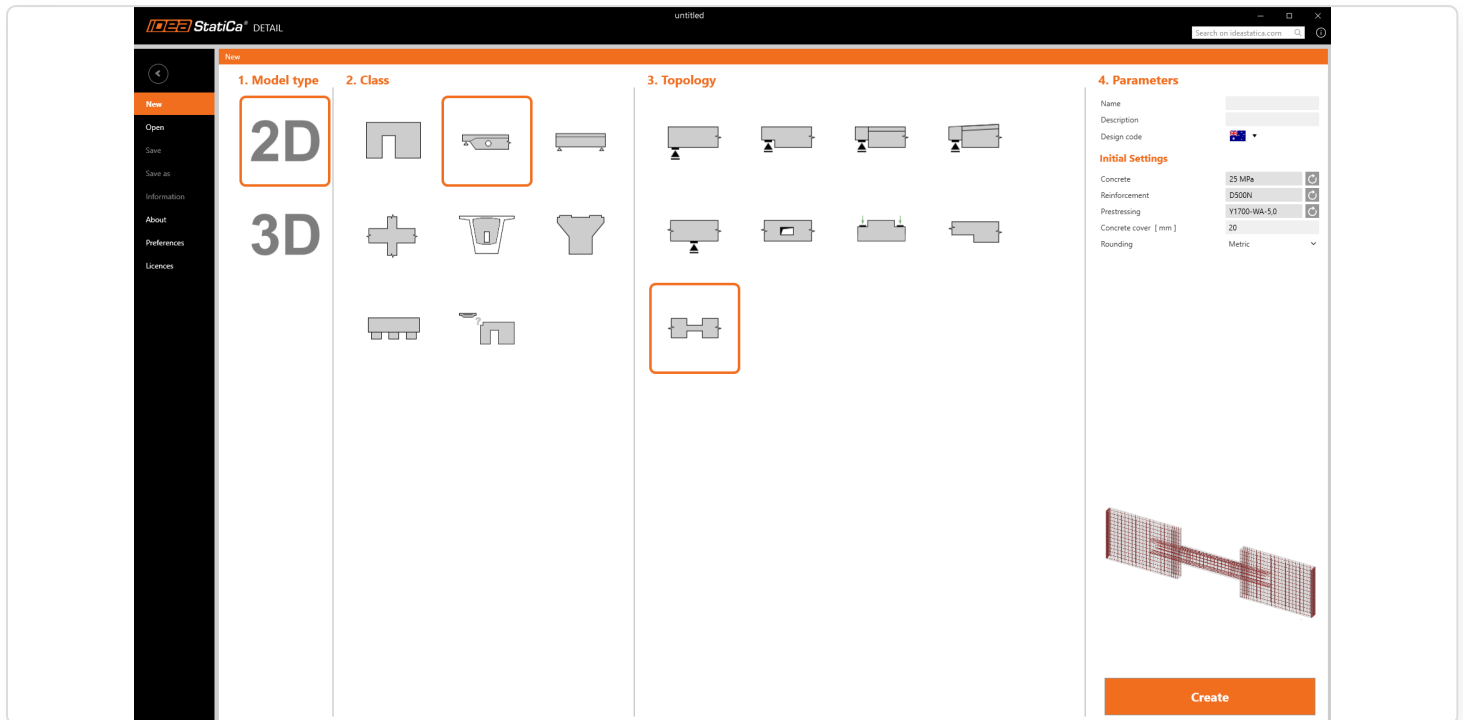

The templates for the Australian Standard include classes for walls, beams, frame joints, foundations, as well as diaphragms and pier caps for bridge engineers.

These templates provide users with a broader range of starting points for modeling, eliminating the need to begin from scratch. Additionally, they serve as inspiration for various approaches to loading models, specifying reinforcement, and configuring supports.

Import from Beam to Detail including reinforcement and prestressing tendons

The integration between Beam and Detail allows the transfer of prestressing tendons and reinforcement when importing an entire design member. This ensures that critical data is preserved for accurate analysis and verification.

In IDEA StatiCa Beam, users can solve complex prestressed beam tasks, including TDA (time dependent analysis) and LTB (lateral torsion buckling). In IDEA StatiCa Detail, they can account for discontinuity regions, such as openings and dapped ends, without the need to remodel or reload the beams from scratch.

Import of prestressing

Both **pre-tensioned** and **post-tensioned** prestressing tendons and strands are imported along with their key properties. This includes **tensioning stress, input values for loss calculation, material specifications, and prestressing position**, ensuring accurate data transfer for analysis and design.

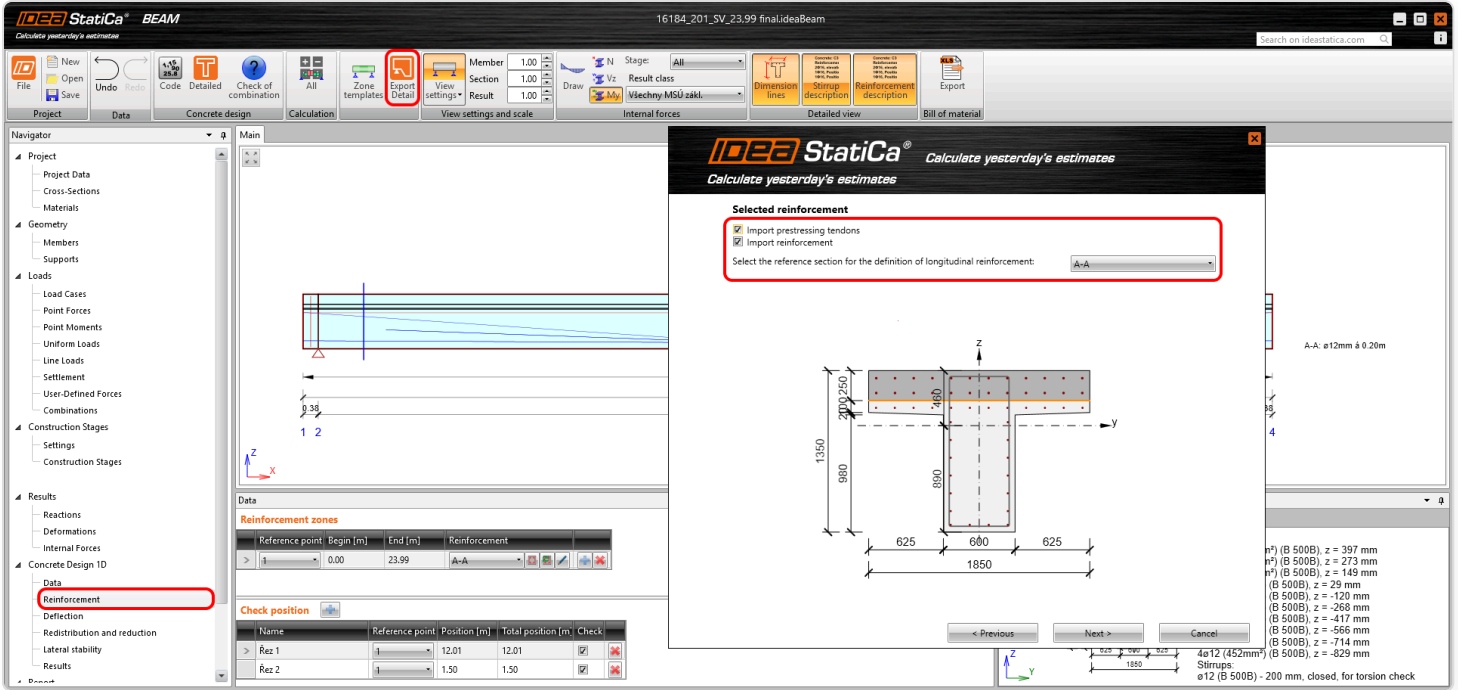

- For post-tensioned tendons, the layout in the XZ plane is transferred, while the geometry in the XY plane is omitted as Detail operates with a 2D plane model. Additionally, the transfer includes material properties, the number of strands per tendon, prestressing origin, anchorage stresses, anchorage set, friction coefficient, and unintended angular change. For more information related to post-tensioning in Detail, including tendon stresses, losses, loading, combinations, etc., read the following article: [Prestressing in Detail - Post tensioned tendons](#)

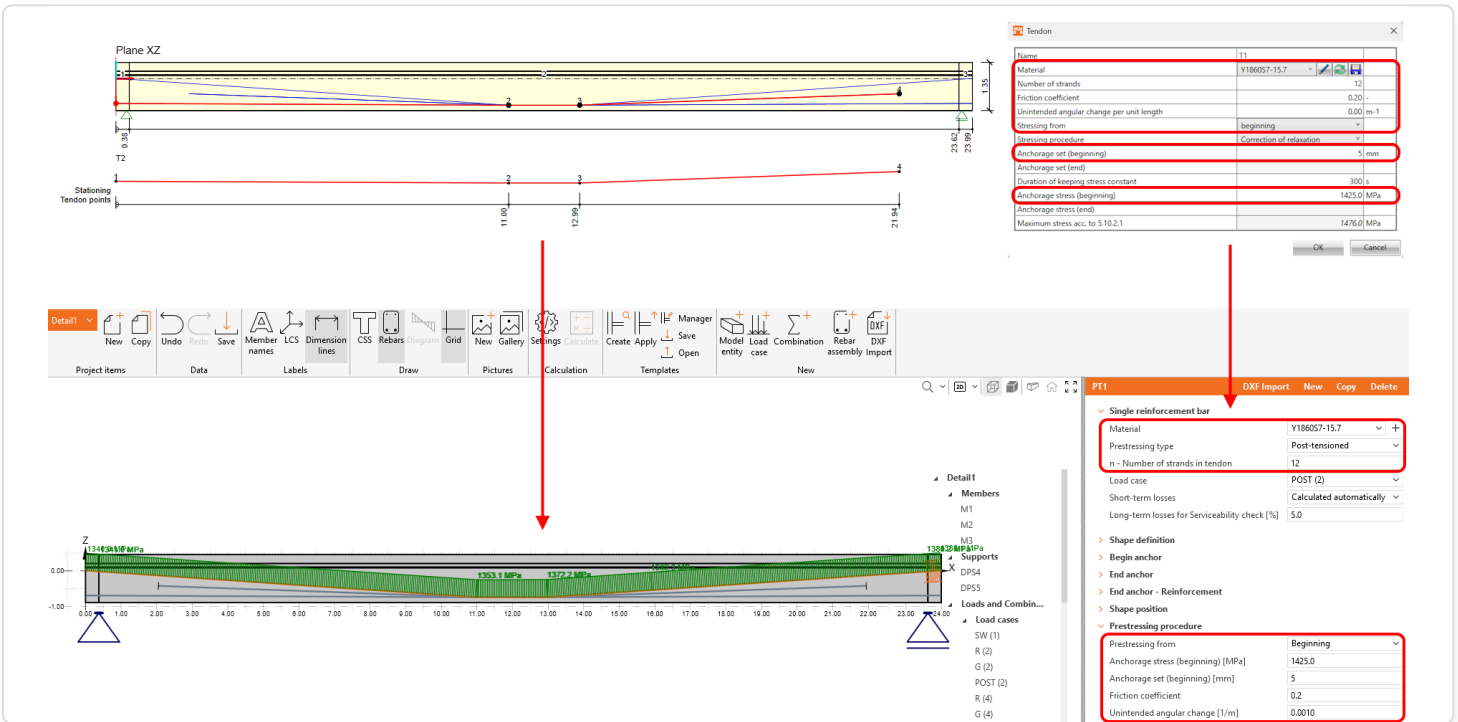

- For pre-tensioned strands, straight strand layers in the XZ plane are transferred. The data included for each layer consists of geometry in the XZ plane, stress immediately after release (σ_{pm0}), blanked lengths, and the number of strands per layer, ensuring accurate prestressing details in the model. For more information related to pre-tensioning in Detail, including tendon stresses, losses, loading, combinations, etc., read the following article: [Prestressing in Detail - Pre-tensioned tendons](#)

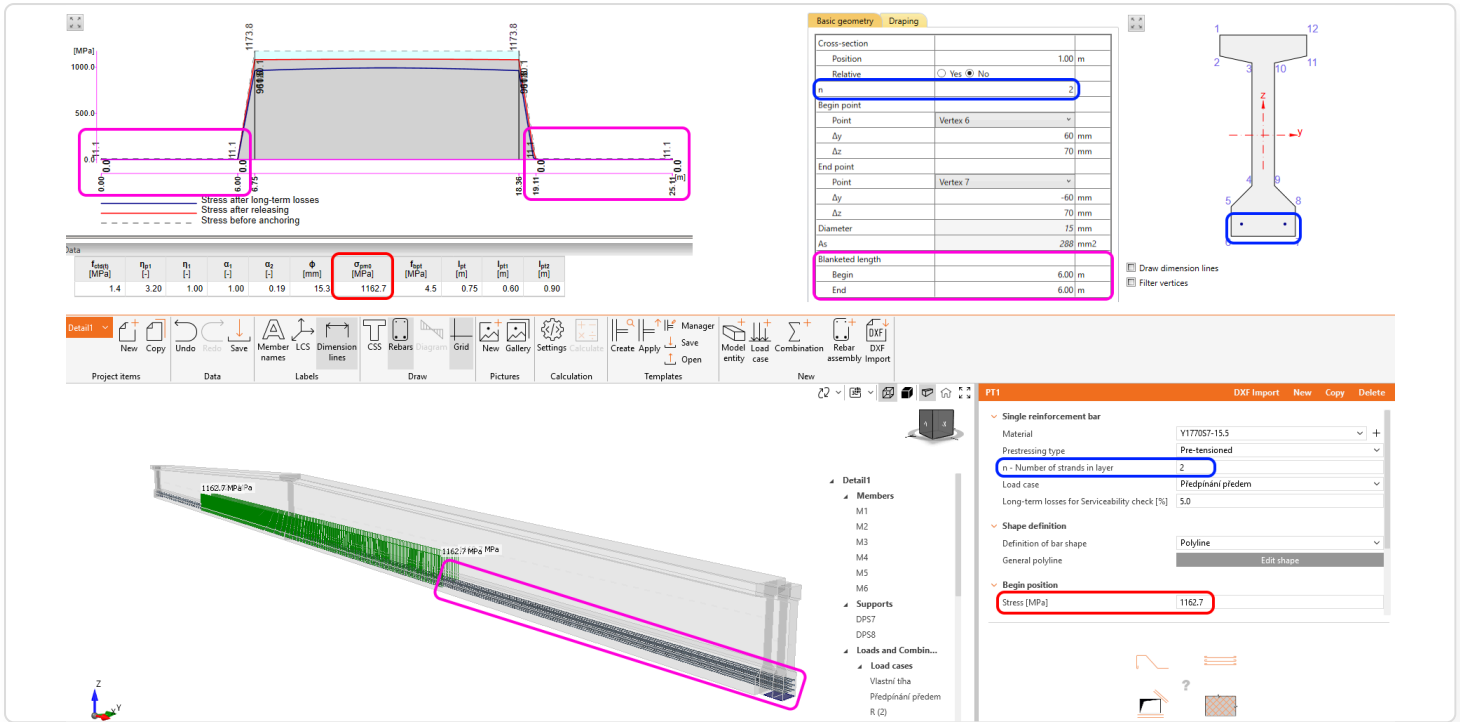

Import of reinforcement

Reinforcement can be imported based on a single section, automatically generating pre-reinforcement within the Detail application. This pre-reinforcement serves as a starting point that can be easily adjusted and refined into its final form.

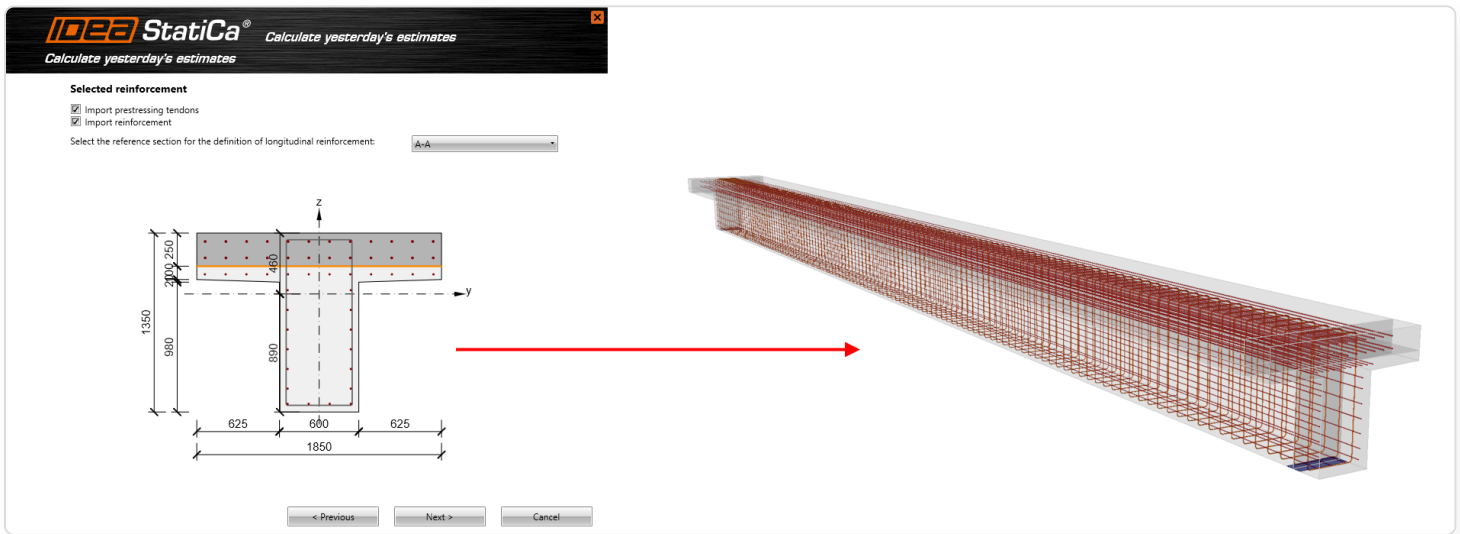

By directly transferring reinforcement details from Beam to Detail, engineers can avoid redundant remodeling, saving both time and effort while maintaining accuracy and consistency across design stages.

Lateral torsional buckling for prefabricated beams

Lateral torsional buckling (LTB) is a stability issue that primarily affects slender members such as prefabricated beams. To address this issue, an advanced geometrically and materially nonlinear analysis incorporating initial imperfections is implemented in IDEA StatiCa Beam.

LTB is a stability failure that occurs in slender beams under bending, causing lateral displacement and twisting. It typically affects long and slender prefabricated beams. Checking for LTB is crucial to prevent sudden failure, optimize structural design, and ensure compliance with safety codes. It is essential to verify all construction stages, including lifting and transportation. The solution is suitable for any reinforced concrete and prestressed (pre-tensioned) **pre-fabricated concrete beams**.

The geometrically and materially non-linear calculation released in 24.1 can capture the mentioned effects and provide results of internal forces including second-order effects. Calculated **internal forces for selected sections are now automatically collected and sent to RCS for detailed code-checks (available from version 25.0)**.

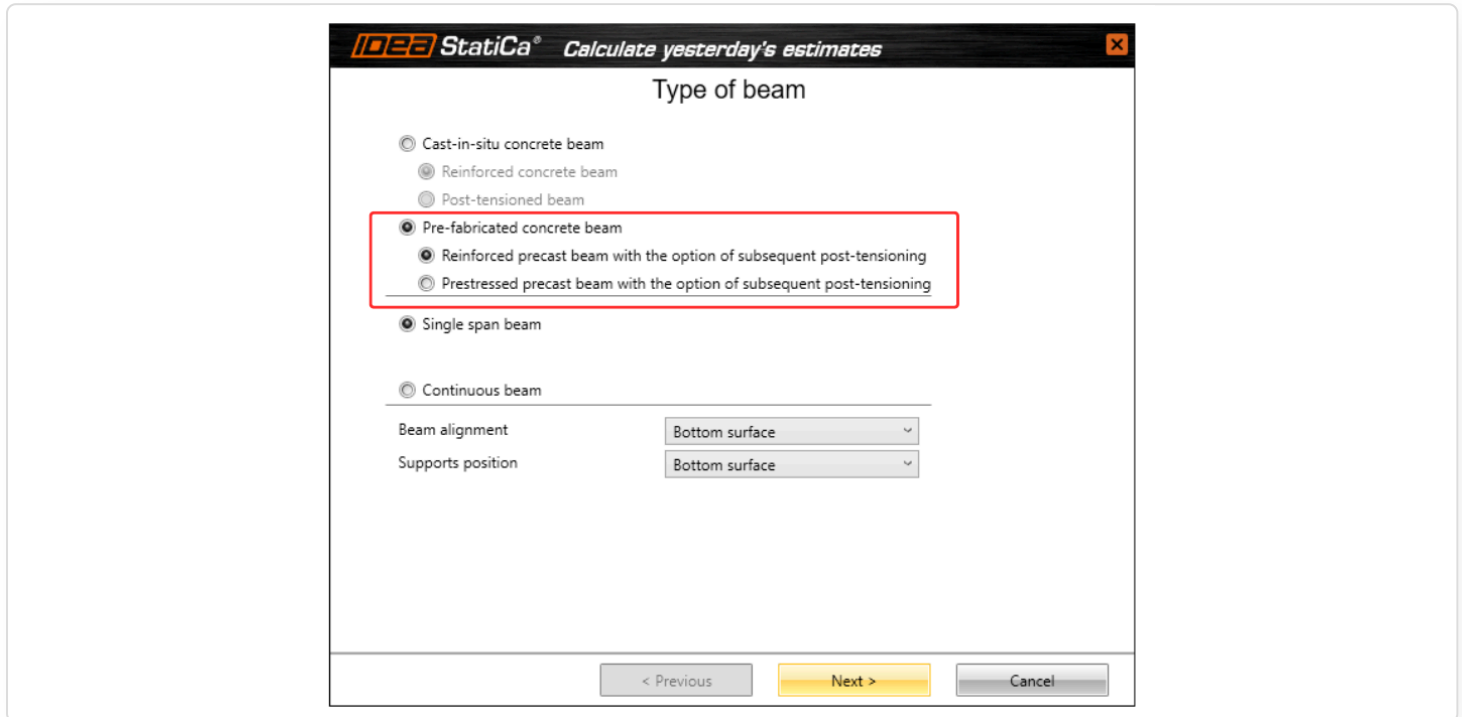

LTB

The option can be selected in the **Design 1D - Data section** next to the Simplified Check and Do Not Calculate options. All necessary input belongs to the **Lateral Stability** section. In the case of **simplified verification**, only the basic dimensions need to be entered. For advanced analysis, more detailed input is required, including construction history, imperfections, and other parameters.

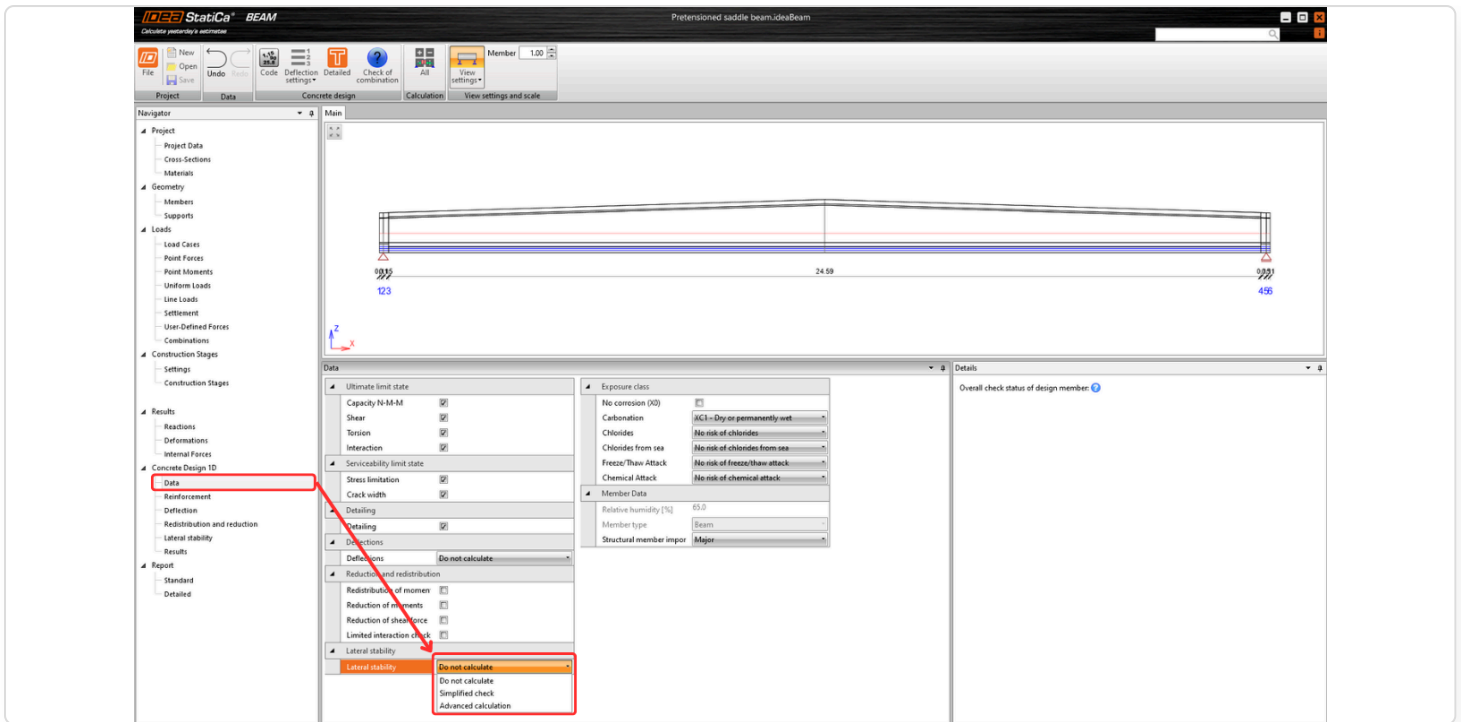

Setting the analysis

Construction stages

Each design situation requires specific inputs due to varying boundaries and times for the code-check. The times for each design situation can be set independently from the construction stages set at the beginning. Concrete properties, such as f_{ck} and E_{cm} , are automatically calculated based on the specified times but can be manually defined by the user if needed.

Imperfection

Also, the value of an initial lateral imperfection can be defined separately for each design situation. There are two options for the definition of lateral imperfection:

- Geometric imperfection – where IDEA StatiCa Beam calculates deformations due to creep and shrinkage. But first, the Initial imperfection needs to be set. It can be a) By code – imperfection is assumed according to EN 1992-1-1, chap. 5.9 (2) as $L/300$ or b) User-defined.
- Overall imperfection – resulting lateral imperfection has to be defined by user.

Inputs for Lifting

Two types of lifting can be defined: **vertical slings** or **inclined slings**, each with specific calculation conditions. The position of the lifting points must be specified in both the longitudinal and transverse directions of the beam.

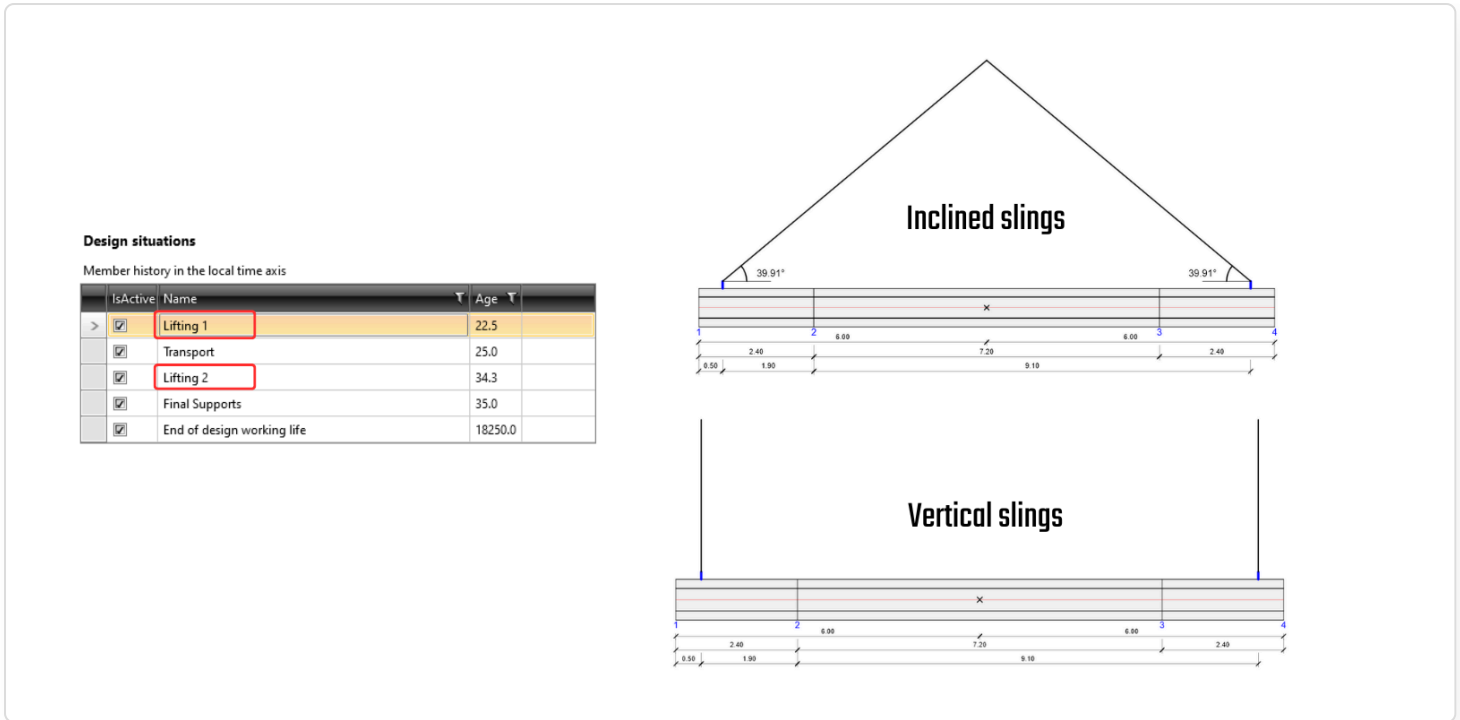

Design situations

Member history in the local time axis

IsActive	Name	Age	
<input checked="" type="checkbox"/>	Lifting 1	22.5	
<input checked="" type="checkbox"/>	Transport	25.0	
<input checked="" type="checkbox"/>	Lifting 2	34.3	
<input checked="" type="checkbox"/>	Final Supports	35.0	
<input checked="" type="checkbox"/>	End of design working life	18250.0	

Inputs for transport

Transport refers to the scenario where the beam is loaded onto a truck with a trailer. Deformation in the Rx direction is restrained solely by the trailer and treated as flexible support with defined stiffness. The user needs to define parameters such as the position of the truck, properties of the trailers, and others.

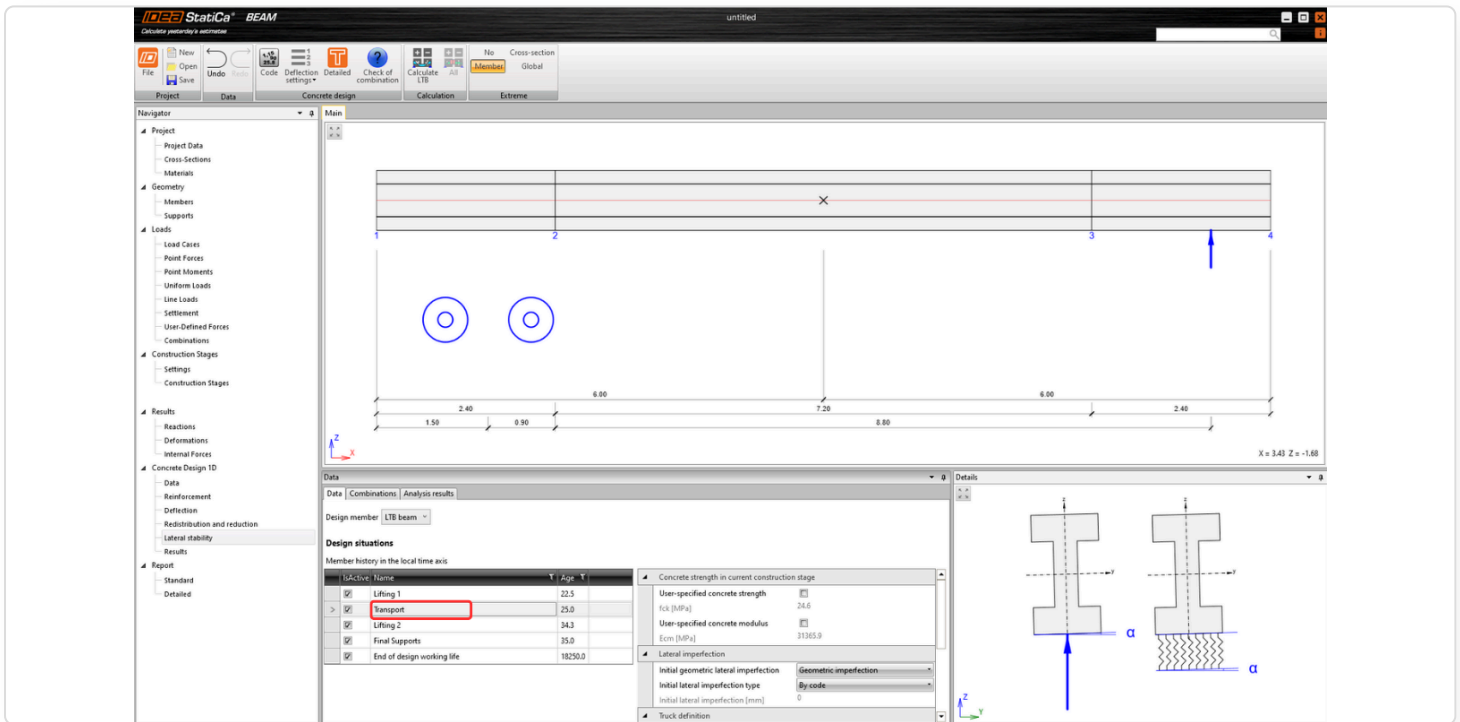

Inputs for Final supports and End-of-design working life

The static scheme for final supports and the end of the design working life is the same, with no option to define supports in the end-of-design working life scenario. The beam is always considered simply supported at its ends. Additionally, the beam can be laterally restrained at specified positions if desired.

Final supports are always positioned at the ends of the beam and can be represented by three types of support: Elastomeric bearings/Forks/Bearing pads with dowels.

Loads

The "Loads" section in the tree of entities in previous design steps defines all the load cases, loads, and load factors. In the section Lateral Stability, dynamic factors for lifting and transport phases and correct non-linear ULS combinations for each Design situation must be defined.

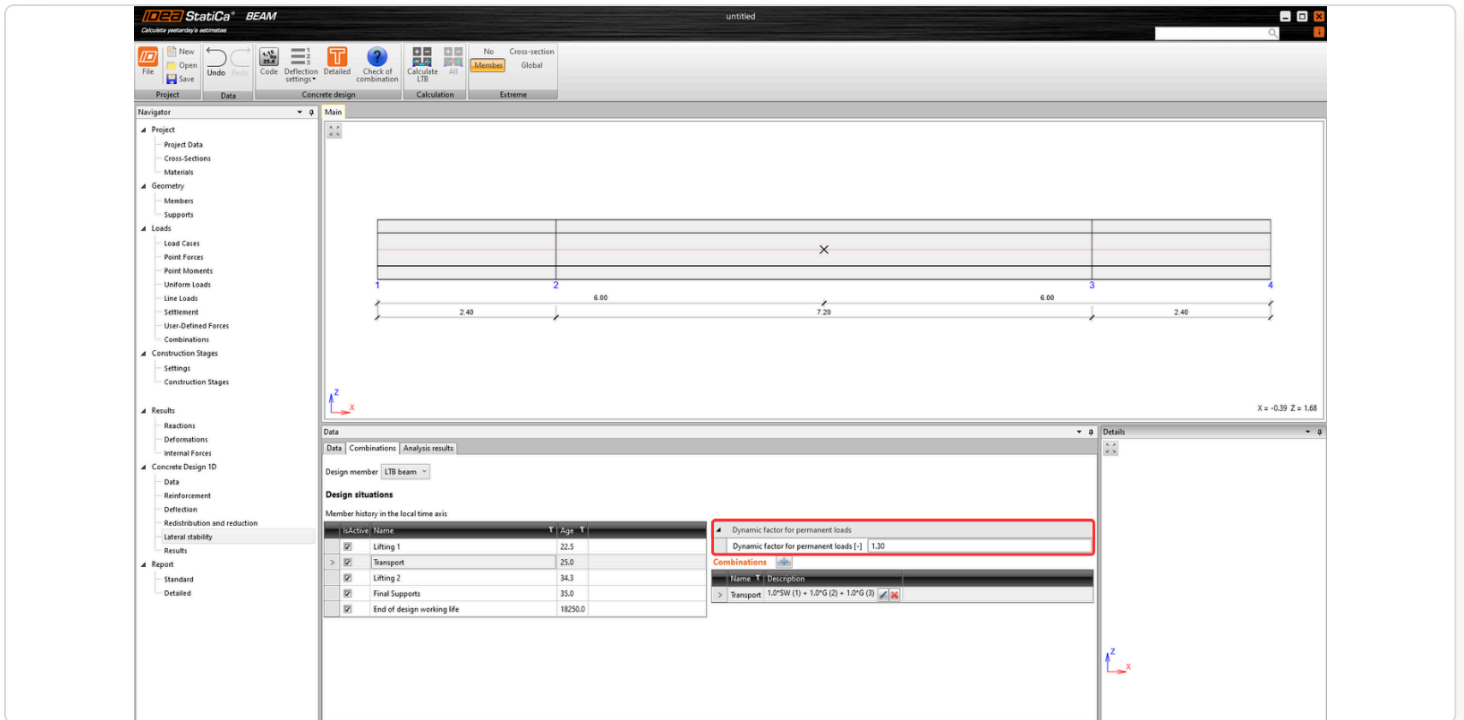

Results

The advanced **Lateral torsional buckling (LTB)** analysis in IDEA StatiCa Beam provides (in addition to reactions, internal forces, and deformations) an evaluation of whether the beam is at risk of collapsing due to stability issues for each defined construction stage. In the event of a structural failure due to LTB, the calculation will not be complete, and the user will see an error message informing them of this situation.

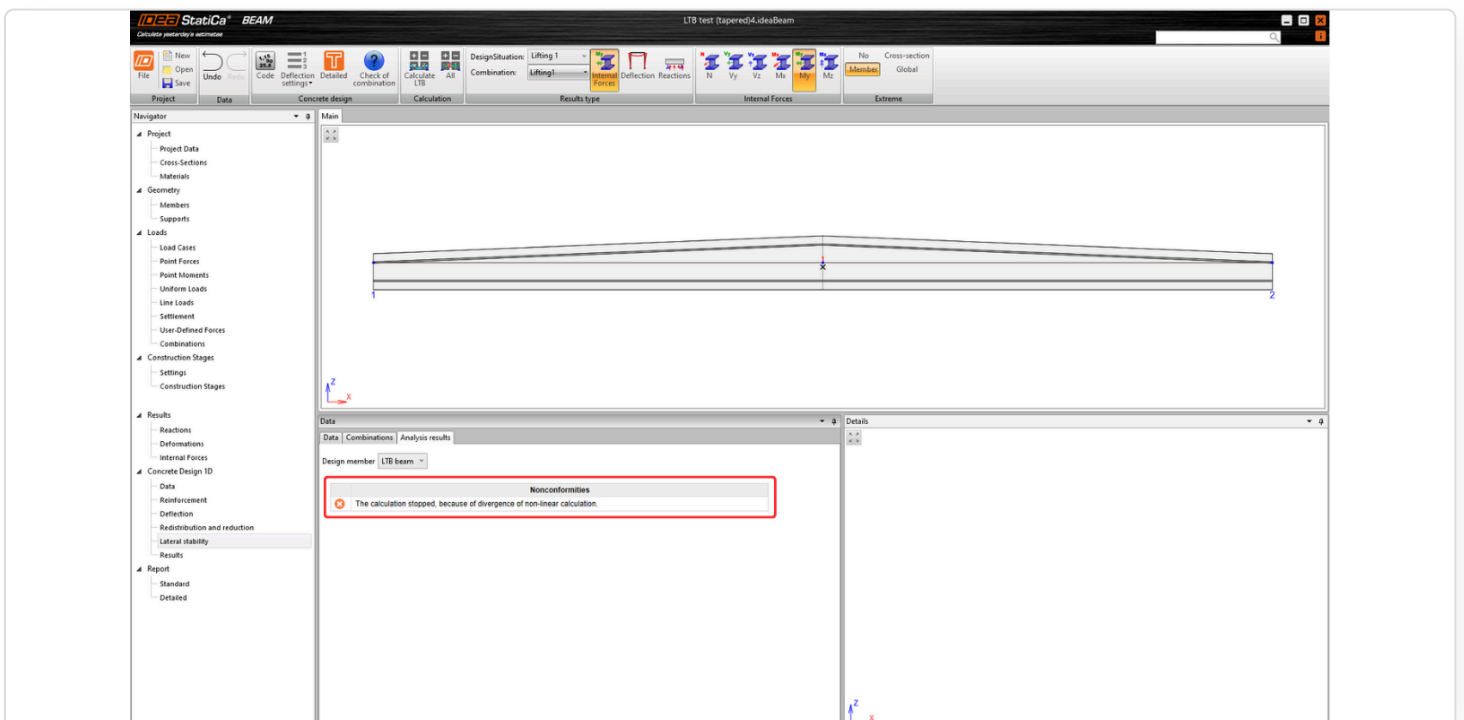

The **Check Settings** tab allows you to define ULS code-check types for the selected member. In the **Check Positions** tab, you can specify multiple section locations where detailed code checks will be performed using RCS.

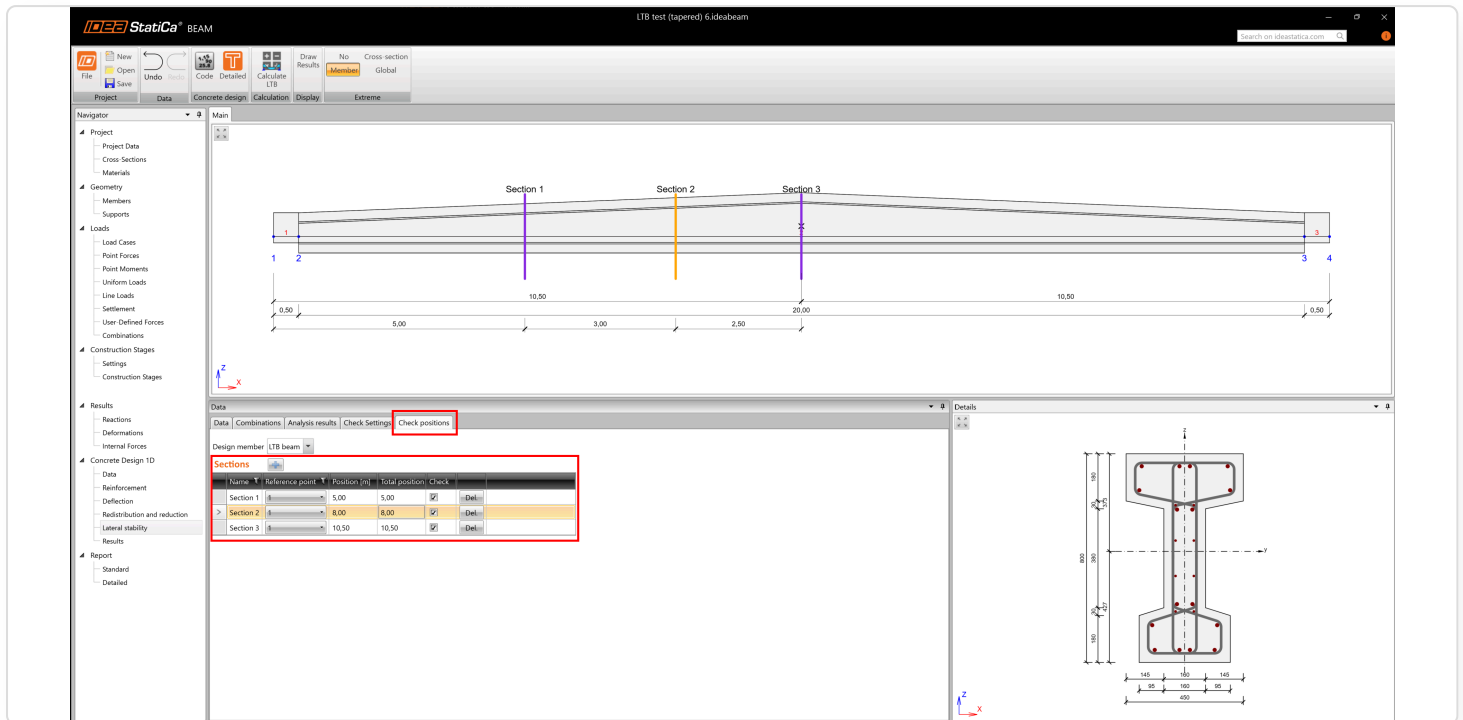

Clicking the **Detailed** button generates an RCS file for the defined sections and selected design situations (LTB analysis has to be completed before opening RCS).

Sectional properties, reinforcement, tendons, and internal forces (including action stages) are automatically imported into RCS, enabling immediate access to results and report generation.

Note

Please be aware that advanced LTB analysis only works for models created in the new version. The calculation will not proceed for older projects, and they must be remodeled.

Released in IDEA StatiCa version 24.1, improved for detailed results in RCS in version 25.0.

Steel Design

Connection Wizard

The Connection Wizard offers a clearer, step-by-step interface for creating connection models, making it easier for all users to access standard templates, use company libraries, and preview the connection with full control over geometry and design.

The wizard provides a starting point for your new model, offering solutions for a junior and advanced user of the Connection app. It provides a set of new parametric templates covering standard connections of all different geometries and types. The company and personal sets are incorporated into the wizard so that the user can start right away with their custom template.

The new style wizard will help you with:

- Finding your preferred geometry and design. This means speeding up the modeling phase and skipping straight to the analysis of the connection. The filtering and search helps with this.
- Starting the design with a template from the Personal and/or Company sets from the Connection Library. No need to create the necessary geometry first. It is easy to load the template directly.
- Using the proper model settings. All the predefined templates were created and set to have the correct model settings. This will help the junior users start and be confident about their projects. A set of standard geometries with predefined parametric templates offers a safe and effective solution for standard connections.

Create the project in the wizard

The creation of a new model follows three simple steps:

- 1 Define the geometry
- 2 Choose the design
- 3 Define the materials and create a new model

For that reason, the wizard is divided into three sections.

1 Define geometry

In the first section, you can **define the geometry** of the model. The new drop-downs control the spatial orientation of the model.

In case you don't find the required geometry in the predefined items, you can use one of the bottom options: **All geometries**

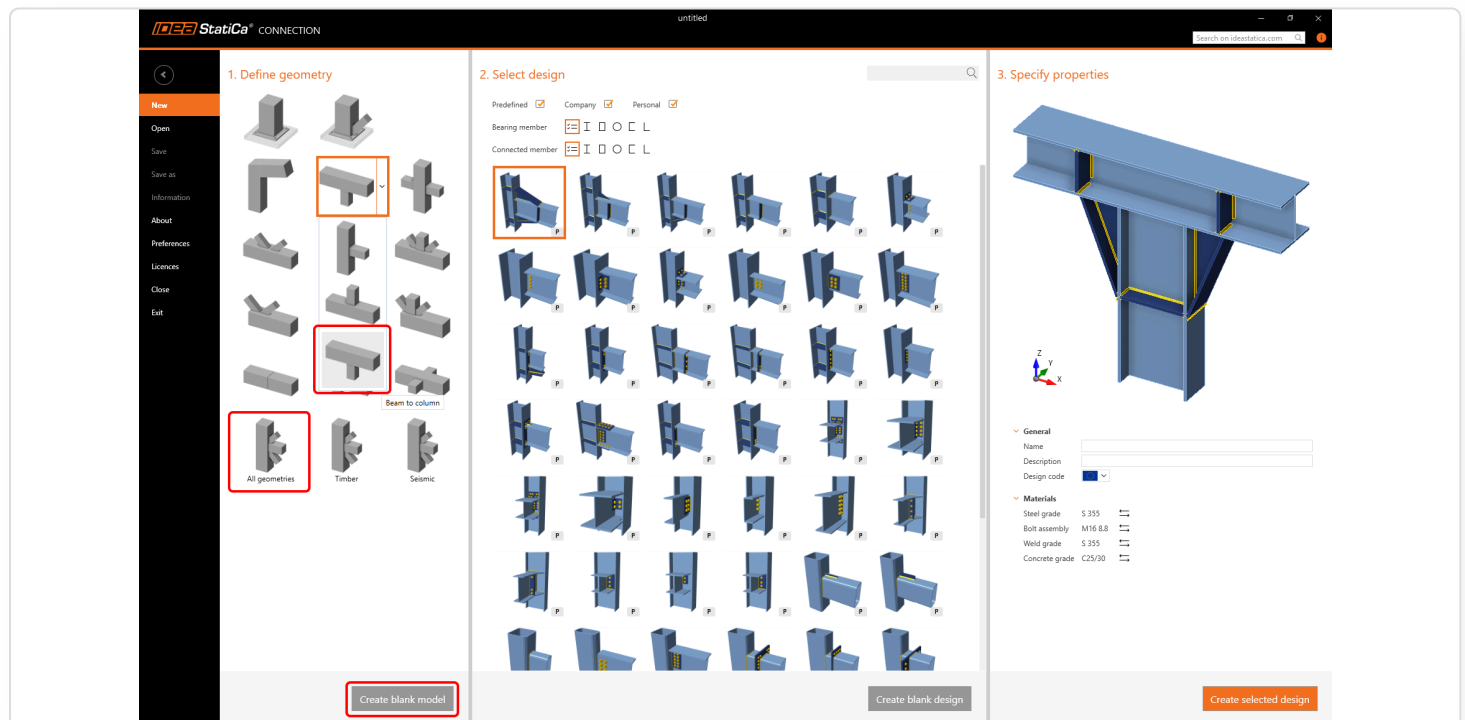

Templates for **Timber connections** or for **Seismic design** are special, therefore, they are listed in specific categories.

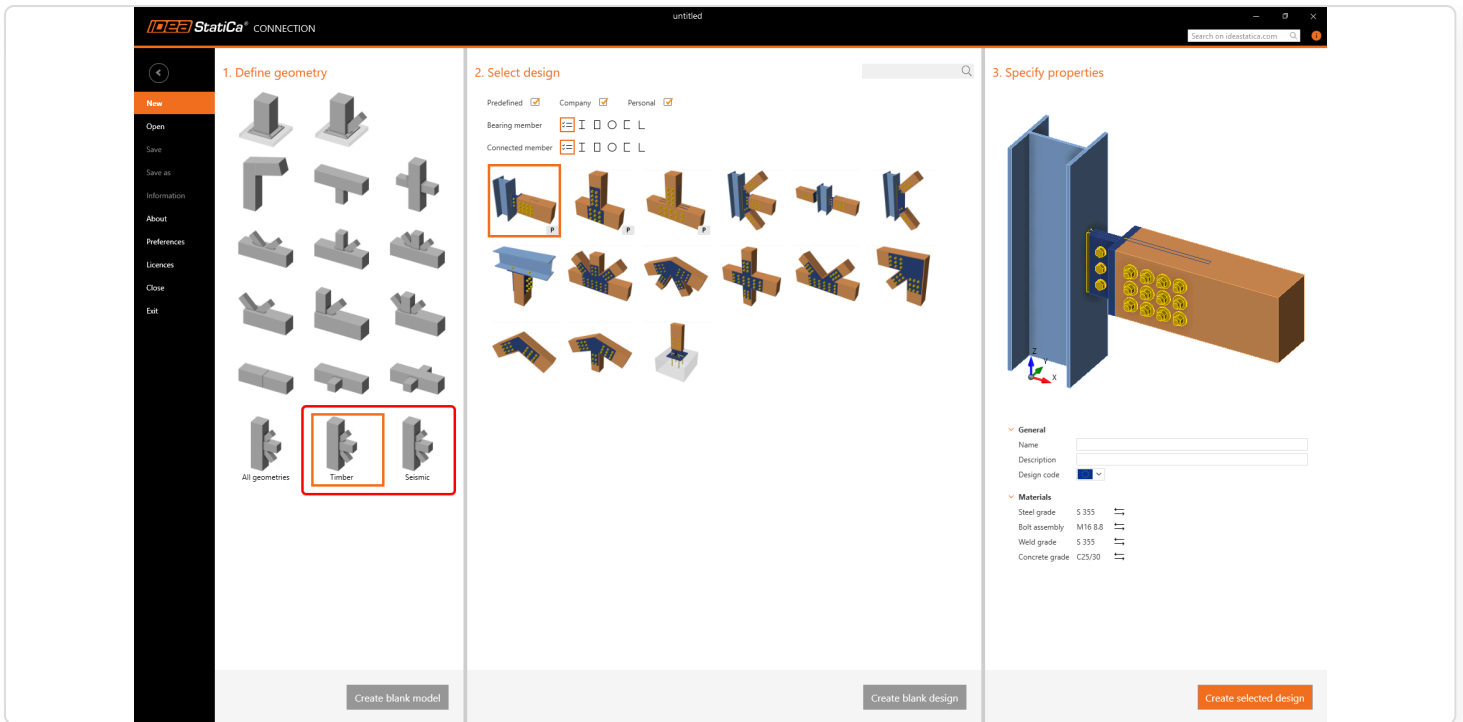

2 Select design

Based on the chosen geometry, the **available templates** are displayed in the second section of the wizard.

You can **filter these templates** based on the **cross-section** of the bearing member and/or the connected members.

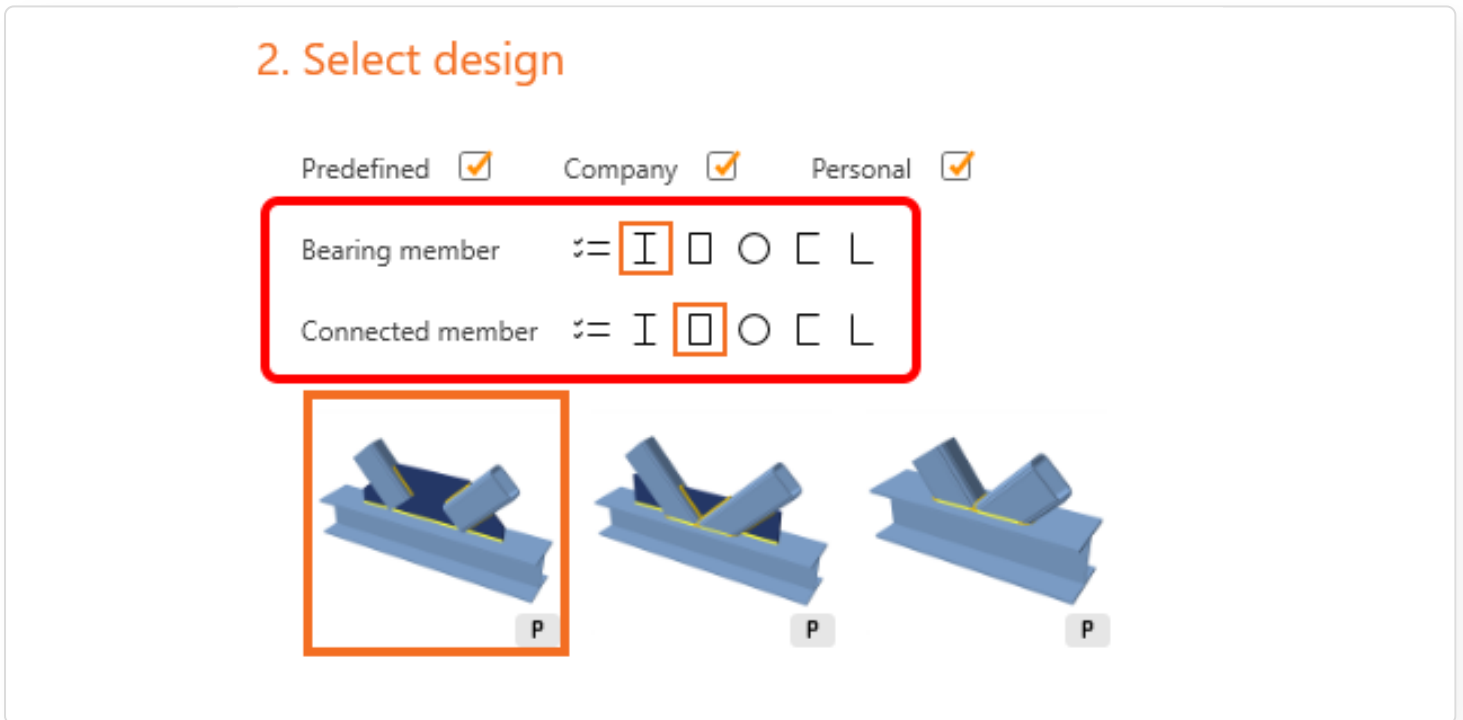

You can also turn on/off the three different sets of templates – in the **Predefined set**, the templates prepared by IDEA StatiCa are available. The **Company** and **Personal** are the sets where you can **save your custom templates**.

2. Select design



Predefined Company Personal

Bearing member I □ ○ L

Connected member I □ ○ L

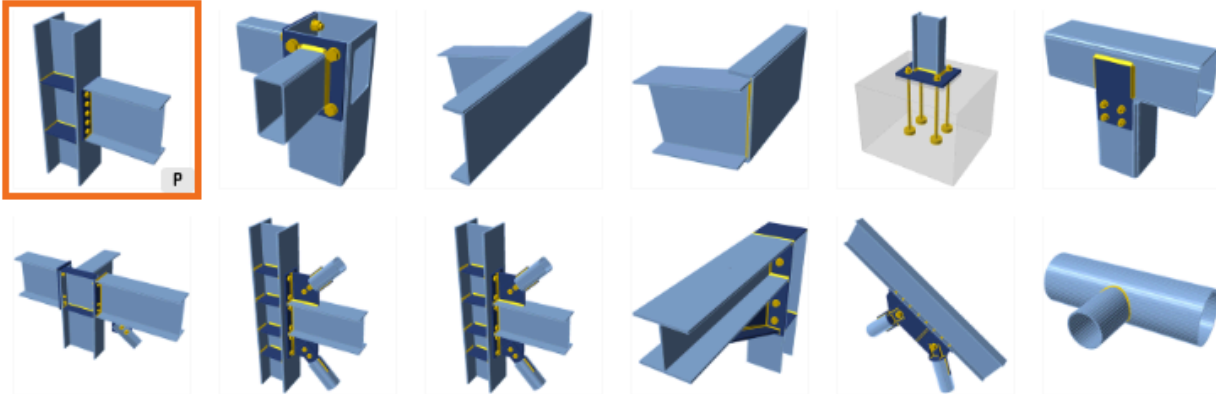

For a faster search of the requested template, a **search box** is available. The Search logic is the same as is used in the Propose dialog in the Connection application. The written term is searched for in the name of the template – the name of the template is shown in the tooltip.

2. Select design

gusset

Predefined Company Personal

Bearing member I □ ○ L

Connected member I □ ○ L

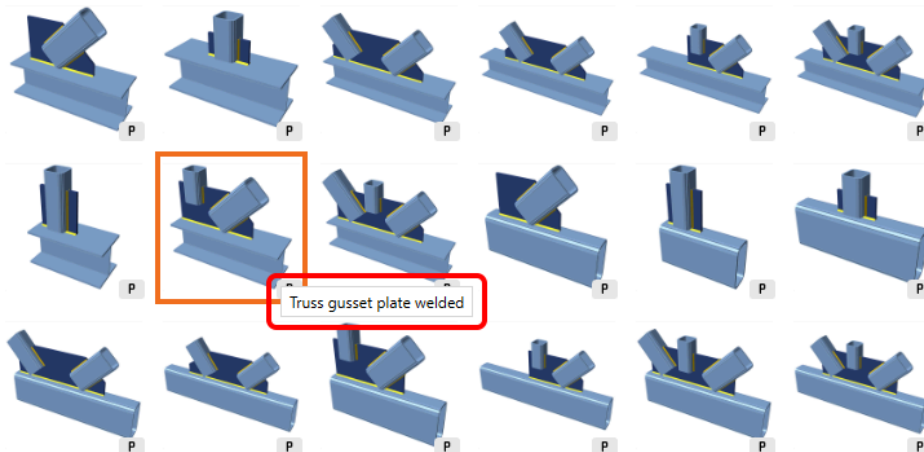

Again, to create an empty design project (with the given geometry), you can use the **Create blank design** button at the bottom of this section.

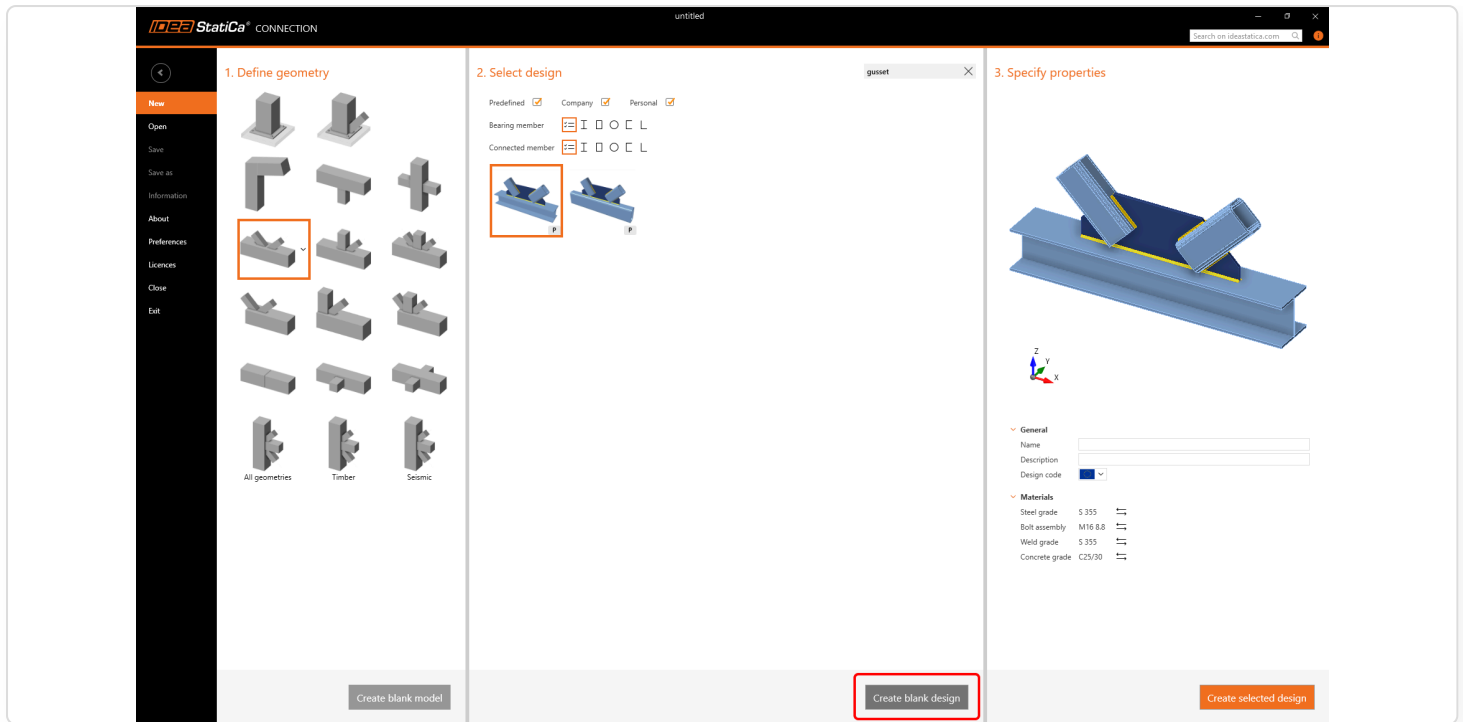

3 Specify properties

All options, such as model info, the used code, and the **default materials**, can be set in the third section.

A **real preview** of the model is shown in the 3D window. You can see what the created model looks like – the applied template on the selected geometry. The model can be rotated or zoomed for investigation of all details.

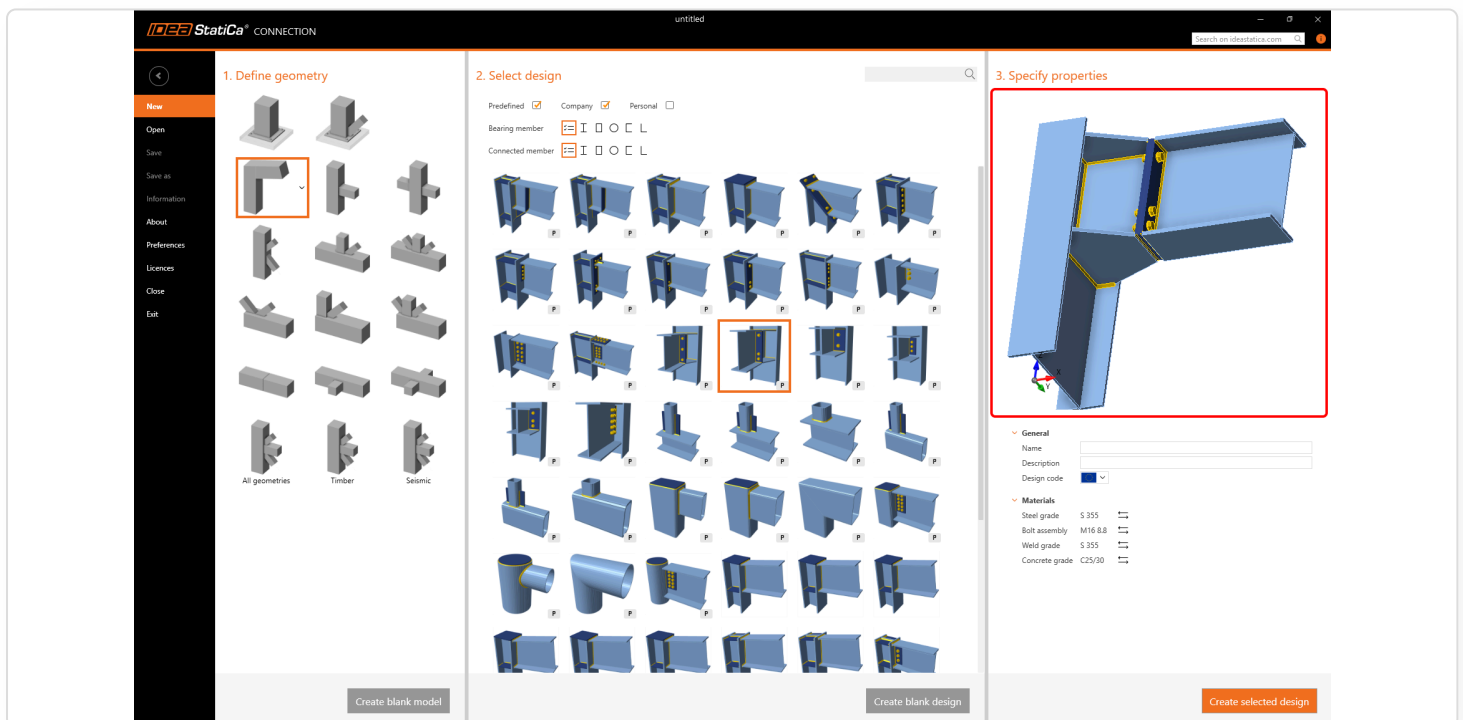

Combination of a parametric template and unrelated operations

By combining a parametric template with a standard operation, the design stays still simple thanks to parameters used in a standard connection but can cover any geometry with an additional operation.

Many nodes in the real structure can't be covered one-to-one by a standard connection type. Designers divide these nodes into separated connections and check them in simple tools or in Excel spreadsheets without considering their interaction, which can cause mistakes in design.

Parametric templates can be combined with other operations

When using a parametric template, there is still an option for adding new operations, so it is possible to add a single operation to an existing parametric template.

In this way, adding, e.g., more stiffeners to the chosen template, can be easily reached.

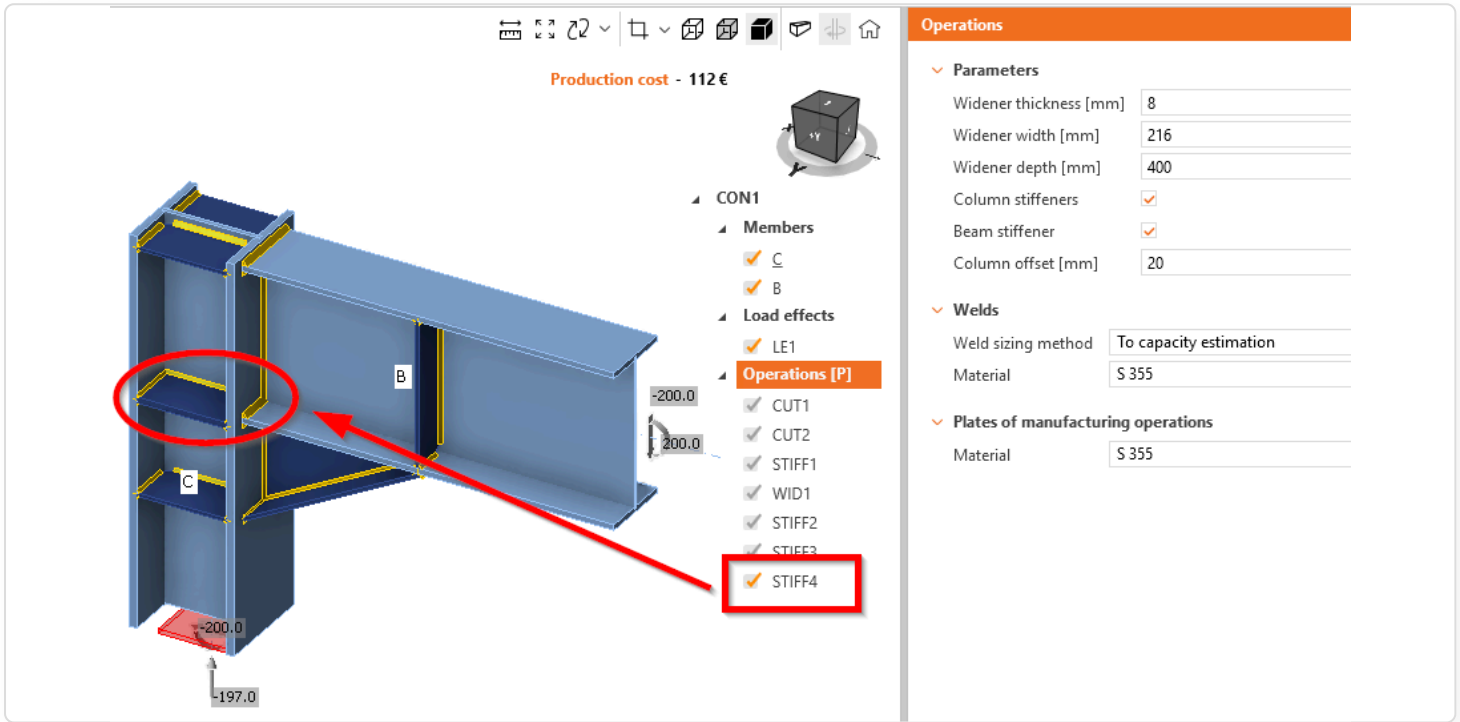

Another example can be a joint that is composed of different connections – some members are not considered in the chosen template.

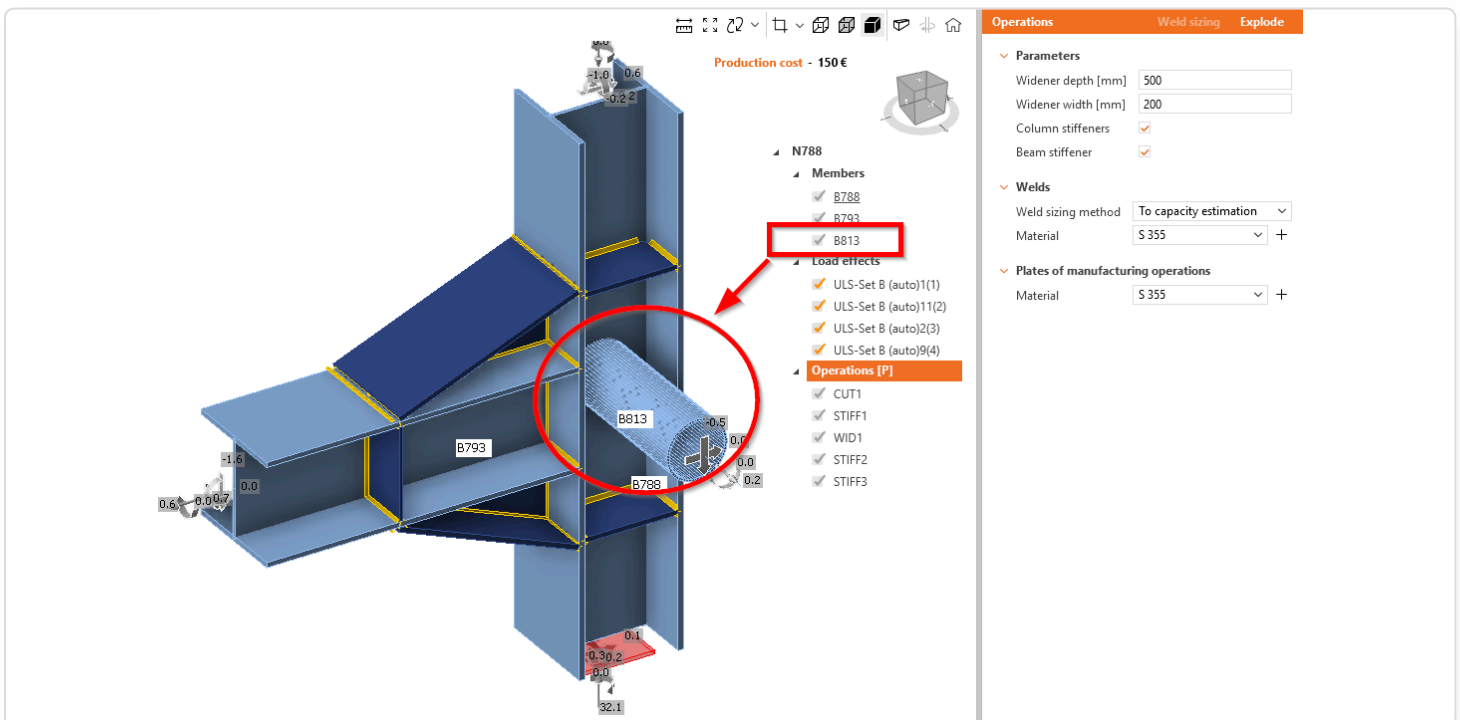

Connecting this additional member with a standard operation is easy to do.

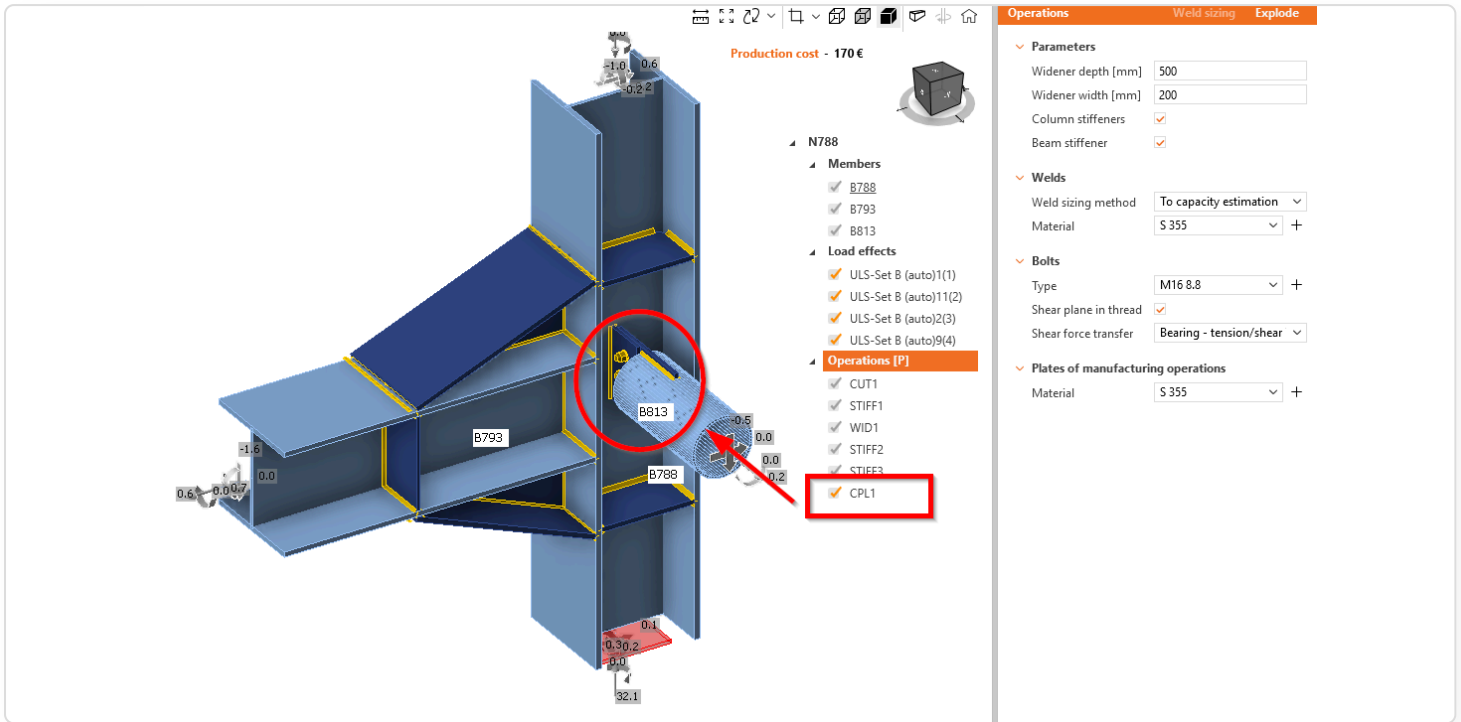

Saving of user-defined cross-sections to MPRL

The user defined cross sections can be saved into the MPRL library where they are then available to use in all future projects in IDEA StatiCa Connection or IDEA StatiCa Checkbot (Steel).

The **Material and Product Range Library (MPRL)** has the ability to save custom cross-sections, just like users can do with materials and bolt assemblies. From MPRL, the cross-section is available for using in users' other projects.

The saved custom sections are available in **IDEA StatiCa Connection** and **IDEA StatiCa Checkbot** – both applications can open the saved MPRL library.

Currently, the user can save the rolled, composed, welded, thin-walled, and timber sections. Paired rolled, I-cuts (T), and general cross-sections are not supported.

Definition of the custom/parametric cross-section

The layout of the library of cross-sections merges rolled cross-sections and standard and parametric/custom sections together.

As an example, the definition of a Rolled Angle is presented.

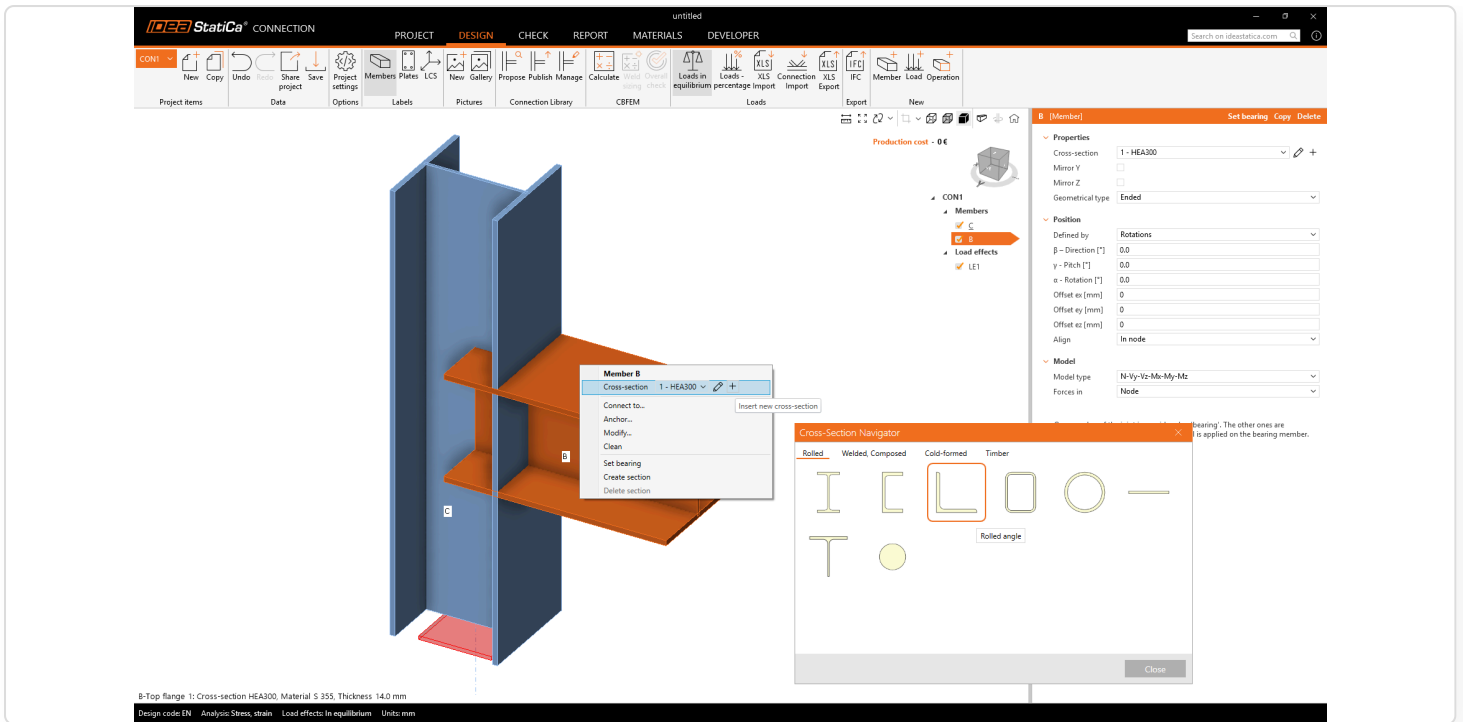

First, the standard section is selected. Using the arrow button, the section can be changed to another one from the library of angles.

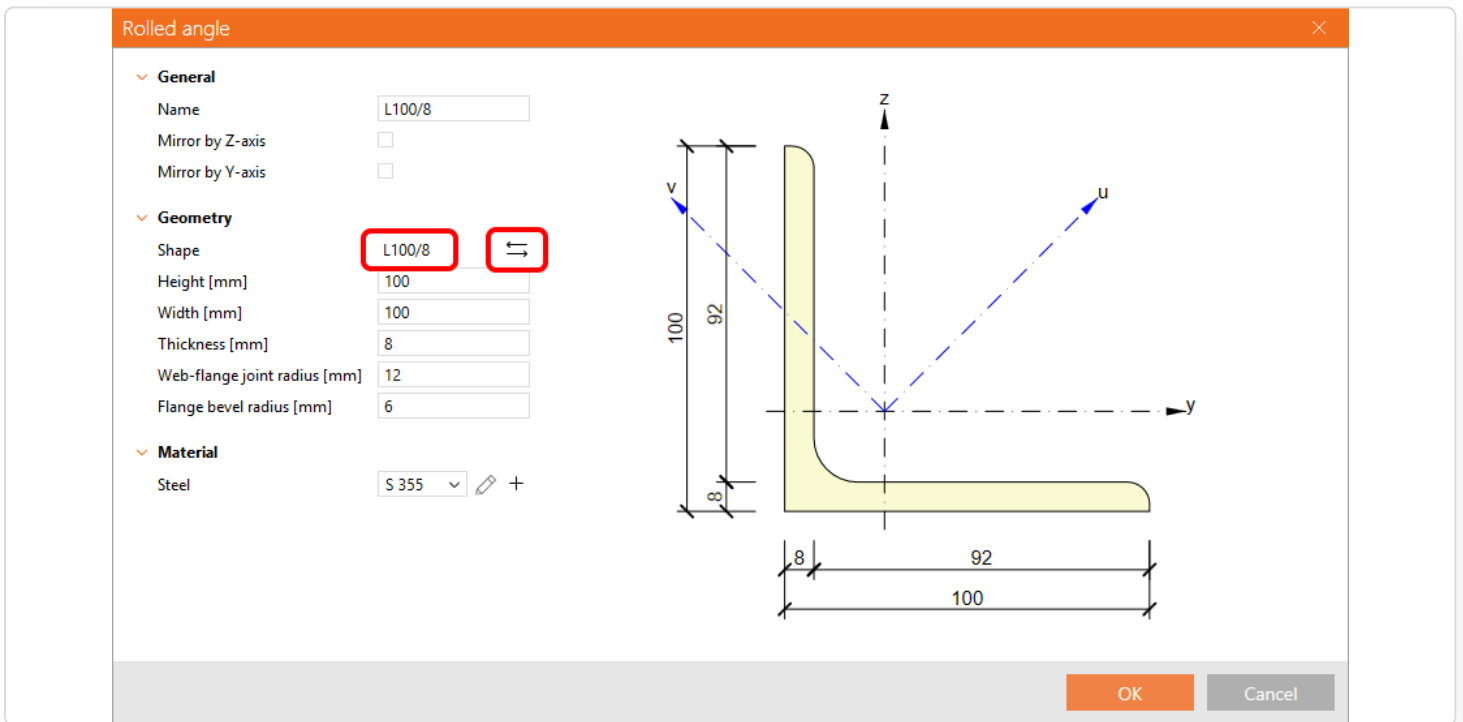

When some parameters are changed (the thickness of the standard section, etc.), the section becomes custom.

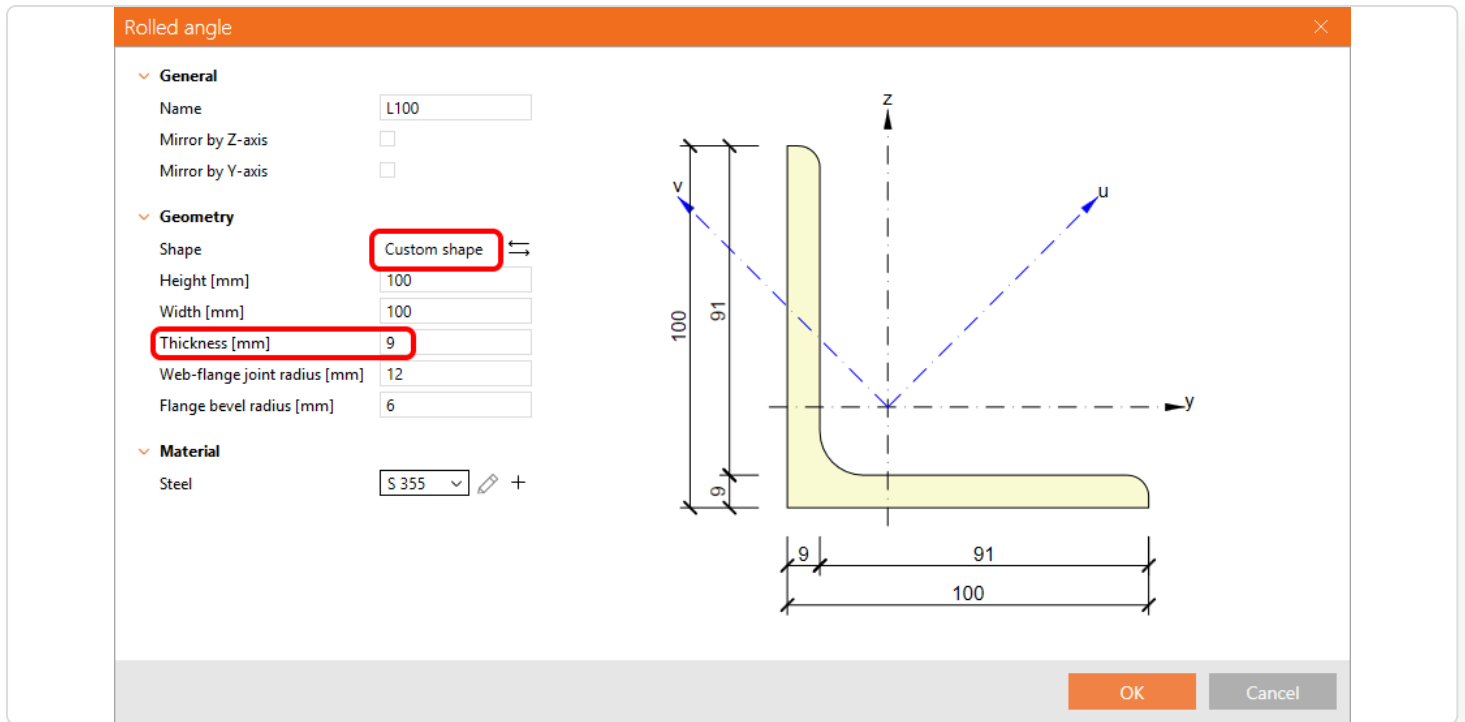

The custom section is displayed in the Materials tab.

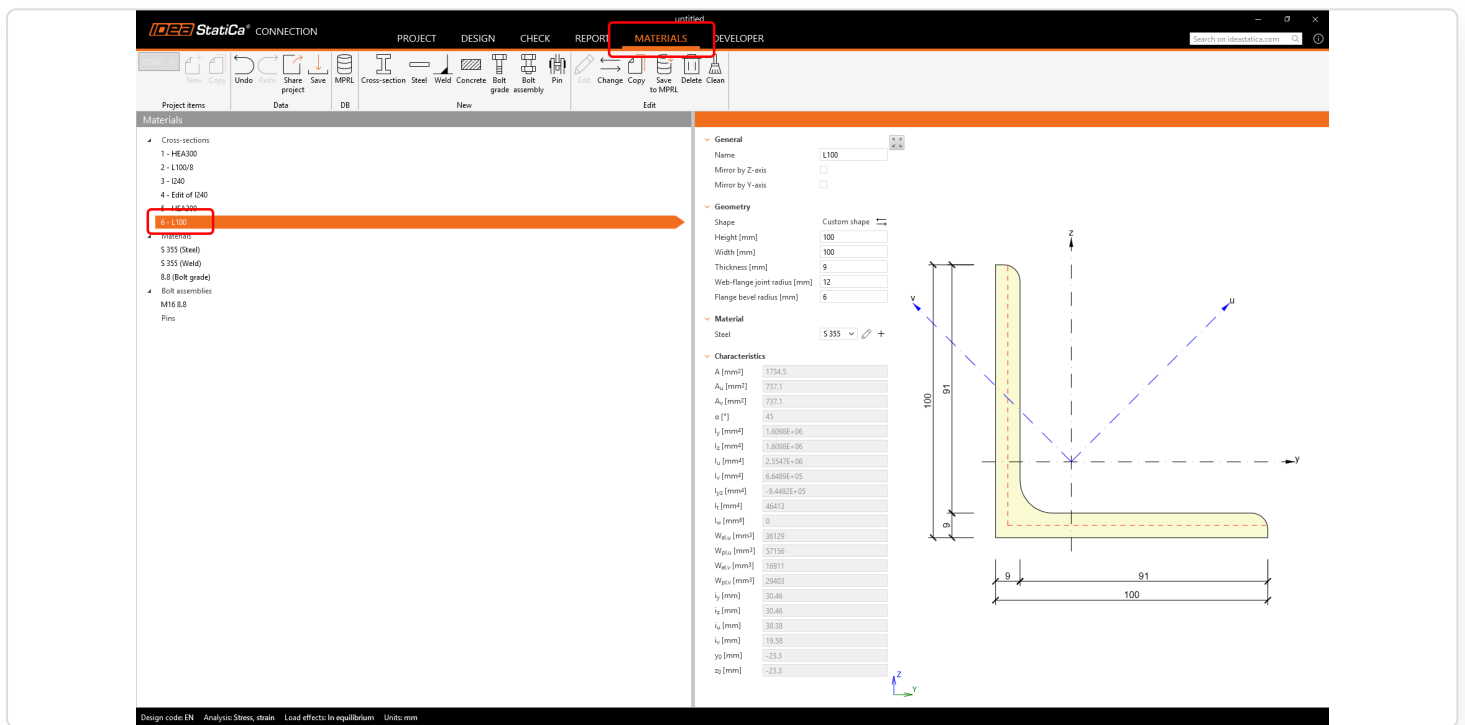

Saving a section into MPRL

The custom section can be saved into MPRL using the button in the top ribbon.

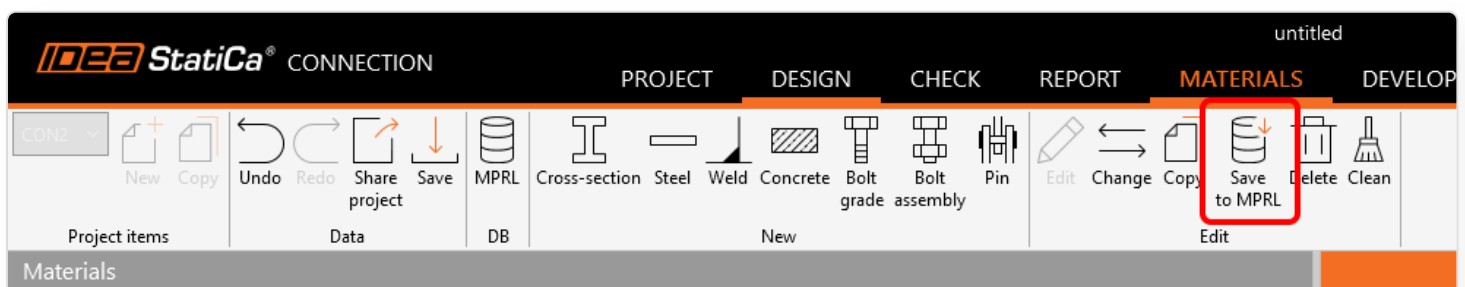

The name of the cross-section can be adjusted and saved to a selected/created table in MPRL.



In MPRL, the custom L (100/9) is saved to the selected location.

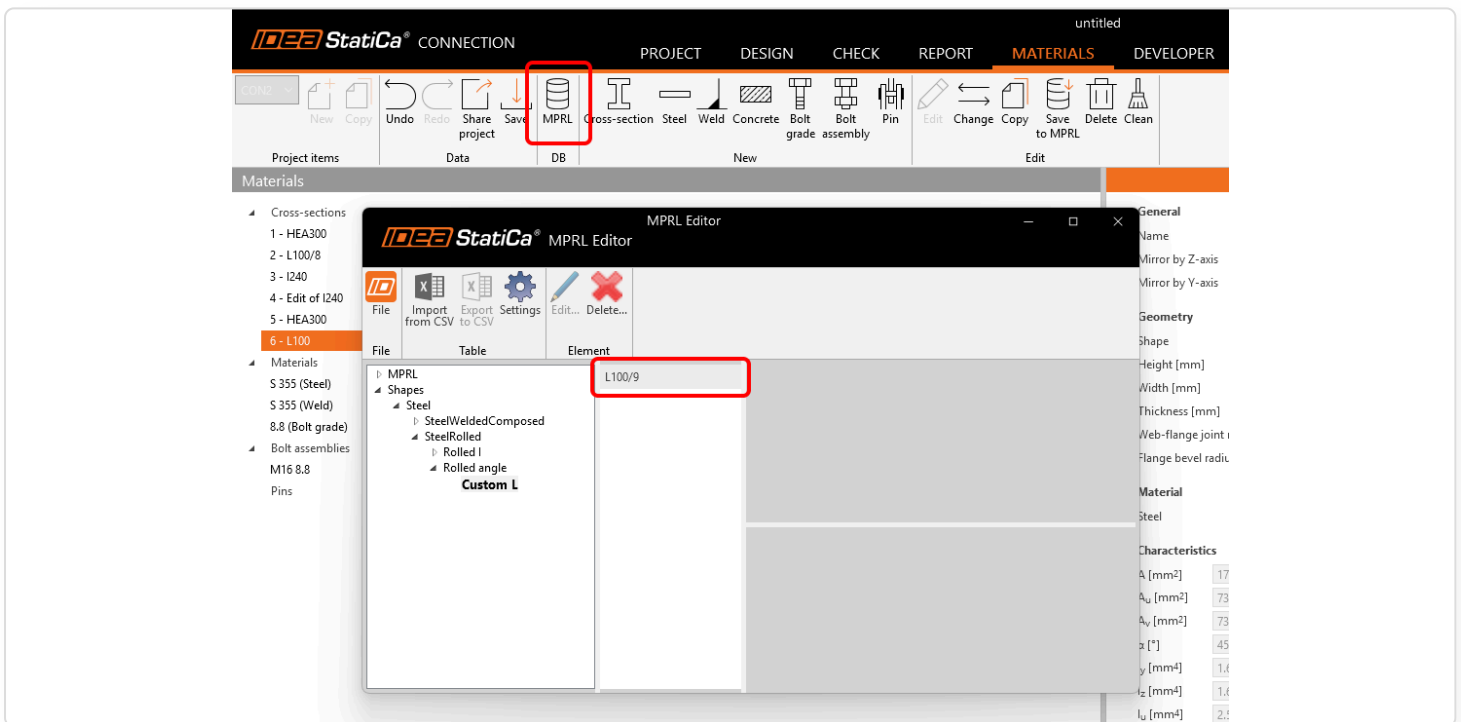

Loading a section from MPRL

In the new Connection or Checkbot project, you can load the previously saved custom cross-sections from MPRL using the standard cross-section library.

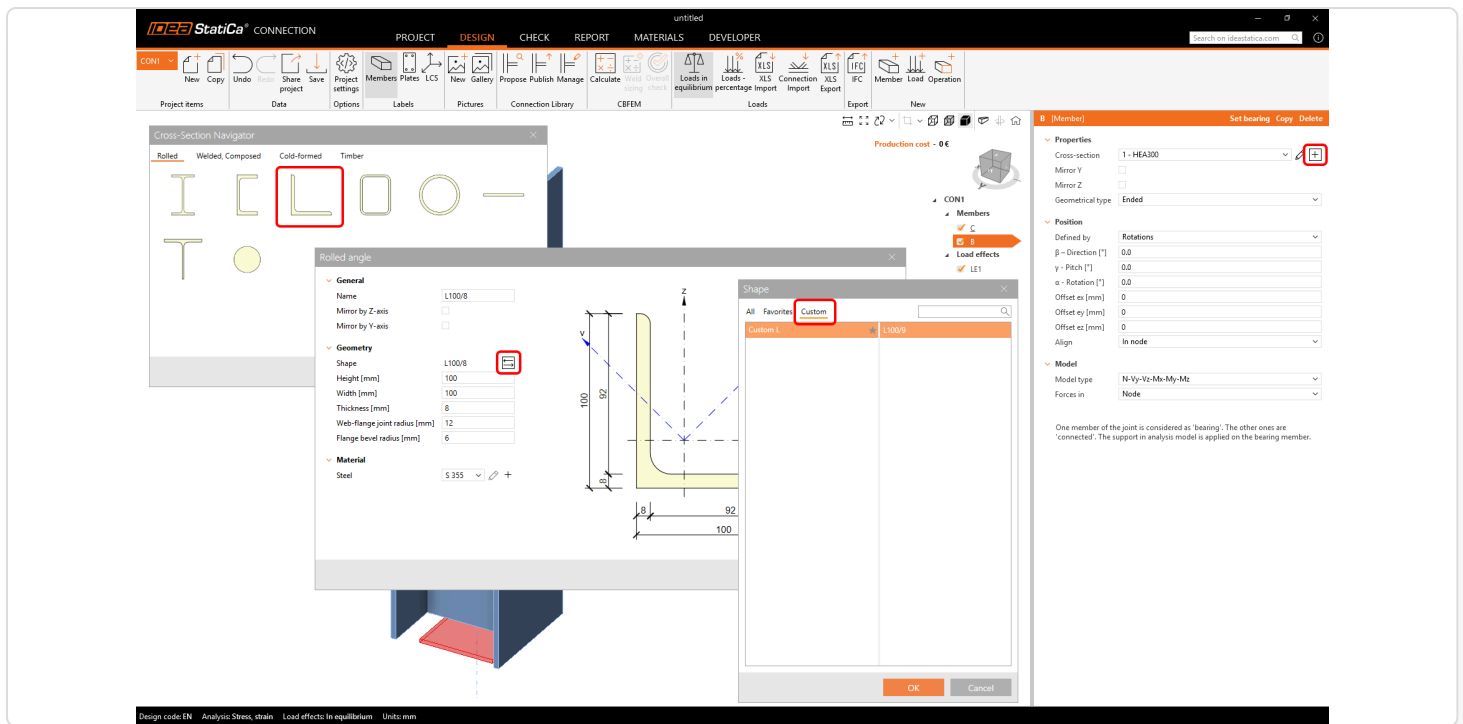

The shape selector includes a **Custom** section, where only custom shapes stored in MPRL under certain types are available. Note that custom tables are also available in All and can be marked as Favorites.

Exporting and importing cross-sections from/to MPRL

Direct export/import of cross-sections from/to MPRL is not available at the moment.

To share the entire custom shapes library, you can share the following file, which can be copied to another computer (to the same location).

%AppData%\IDEA_RS\user_mprl_v2.sqlite

Limitations

- Saving the general section created by the General section editor is not available at the moment.
- Saving the compounded (paired) sections: 2I, 2Uc, 2Uo, 2Lt, 2Lu, Box 2i, Box 2U, Box 2L, Box 4L is not available at the moment.
- Saving concrete sections is not available at the moment.

Released in IDEA StatiCa version 24.1.4.

Slotted holes for the selected plate

Slotted or oval holes for bolts can be assigned to any plate of the bolted connection, even to multiple plates.

This enables designers to decide about the structural behavior and constructability of the joint.

Users can model real-world conditions more accurately by selecting which plate will include slotted holes, e.g., either in the fin plate or in the web of the connected member, as is typical in floor beam connections.

If the design requires it, slotted holes can also be applied to multiple plates. Previously, users couldn't define the location of slotted holes, leading to incorrect bolt checks. With this improvement, bolt checks are now aligned with the actual design scenario.

Where can the slotted holes be used?

- The slotted holes can be set to any plate that is contained in the bolt assembly
- They can be set to one or more plates
- They can be defined for plates of the analyzed member

Defining slotted holes

The shape of the bolt holes can be changed in the Editor of the plate. You can open the Editor by selecting the plate in the 3D scene with the right mouse button. Another option is to use the Editor button in the operation header (the orange strip).

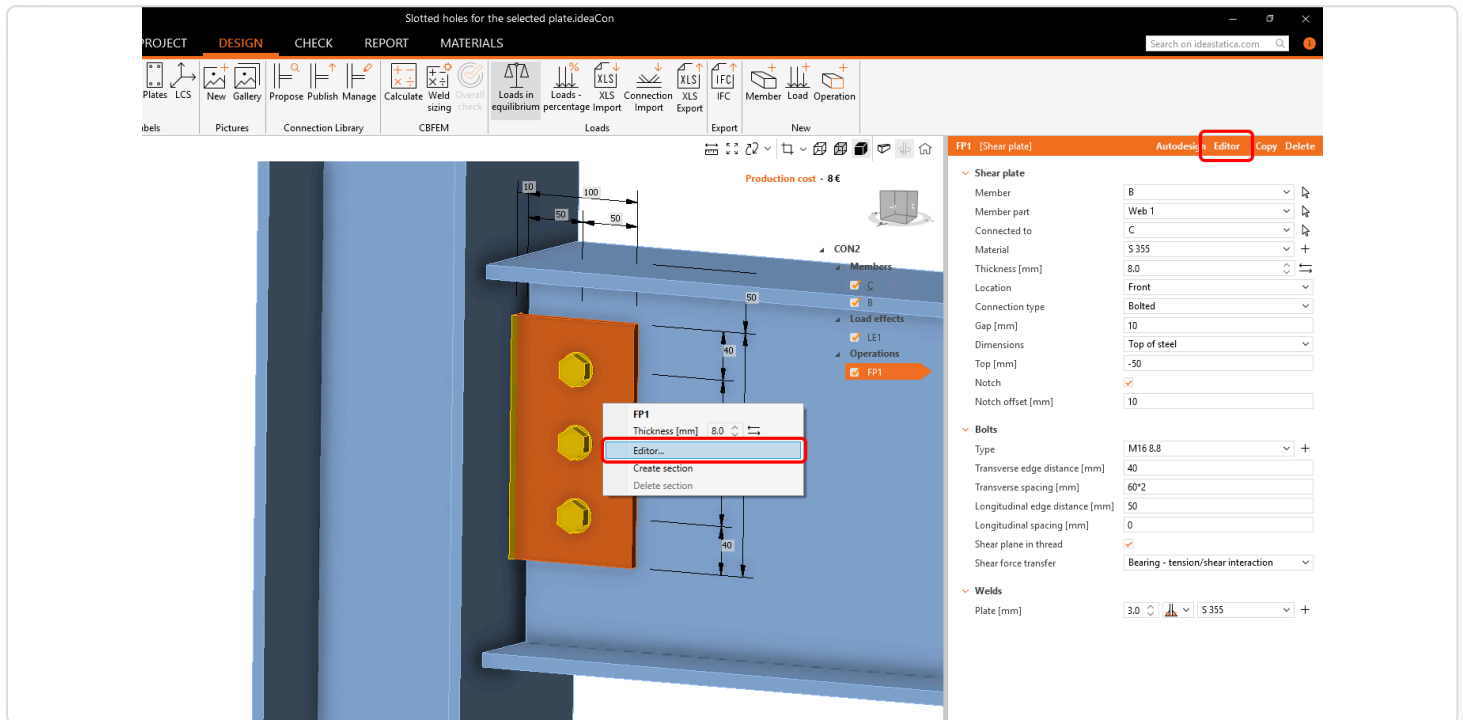

In the plate Editor of the plate containing the bolt, there is a list of all the plates that are connected by selected bolts. In the list, you can define, on which plate the holes will be changed to slotted.

Variant 1: Slotted holes for a fin plate

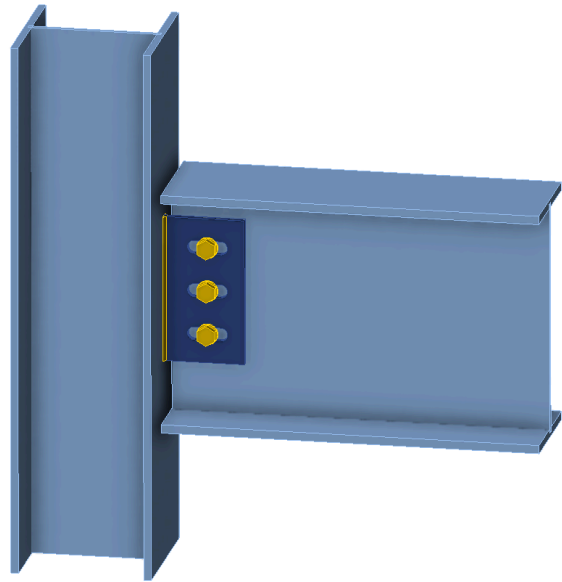
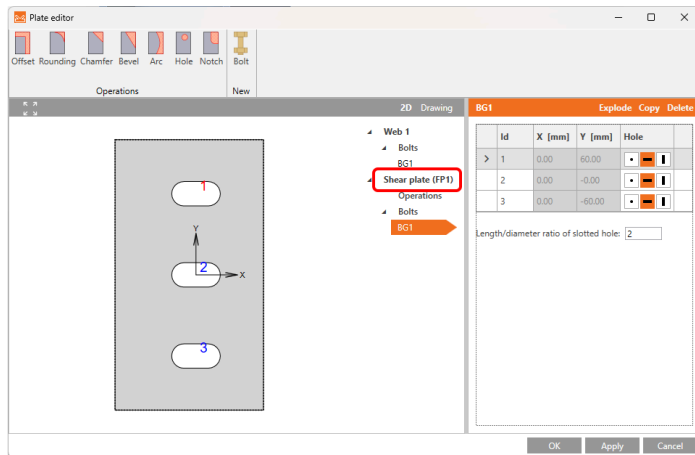

Variant 2: Slotted holes for a beam web

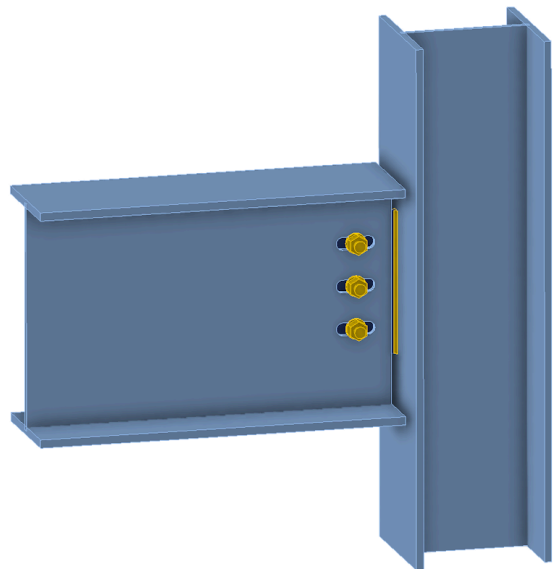
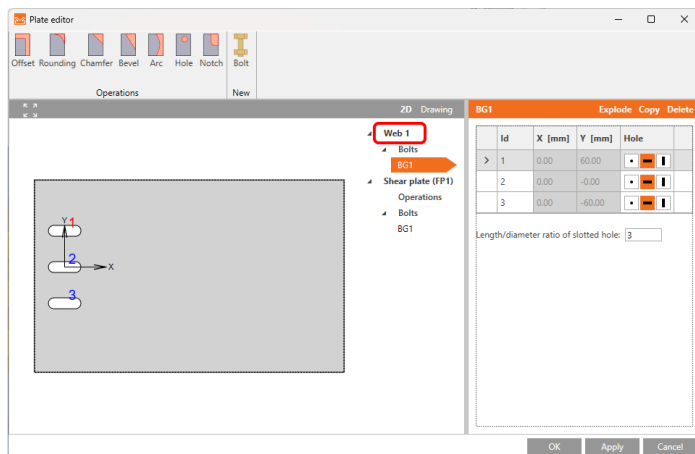

The slotted holes can be assigned to **multiple bolted plates**.

Nevertheless, be aware that there must always be **at least one plate with standard holes** so that the numerical conditions are followed.

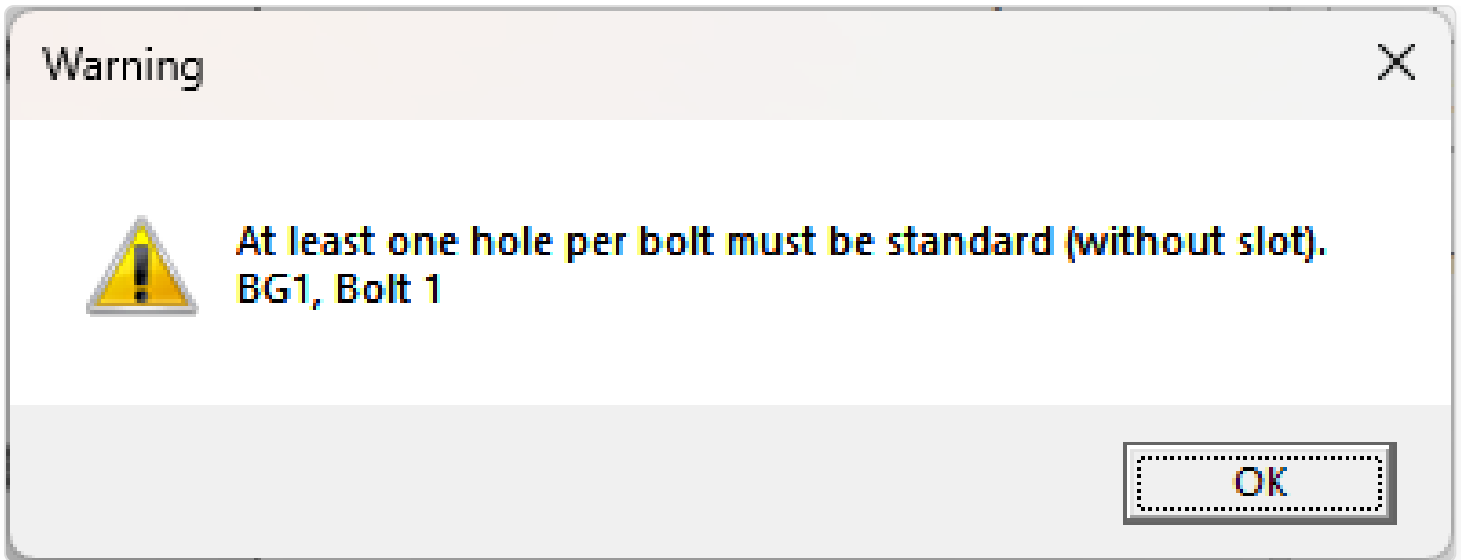

From the [general part of the Theoretical Background](#): Bolts in standard holes can transfer shear force in all directions, bolts in slotted holes have one direction excluded and can move in this selected direction freely.

To read more about the slotted holes in different standards, go to [EN](#), [AISC](#), [CSA](#), [AS](#), [HKG](#), [IS](#), [GB](#), and [SP](#) Theoretical Backgrounds.

Custom sizes of the bolt assembly can be defined in the Material tab and saved to [MPRL](#).

Load effects displayed in the scene

To assist when reviewing the results, the calculated load effects are displayed in the scene in the Check tab. This helps engineers select the results for a particular calculated load effect.

When more than one load effect is used, users can check what effect every single load effect in the structure has in the results. This can help users to understand the overall results that are presented.

For easier orientation, all calculated load effects are shown directly in the tree in the scene under the Check tab, so users can quickly choose the load effect and check the results for the selected one.

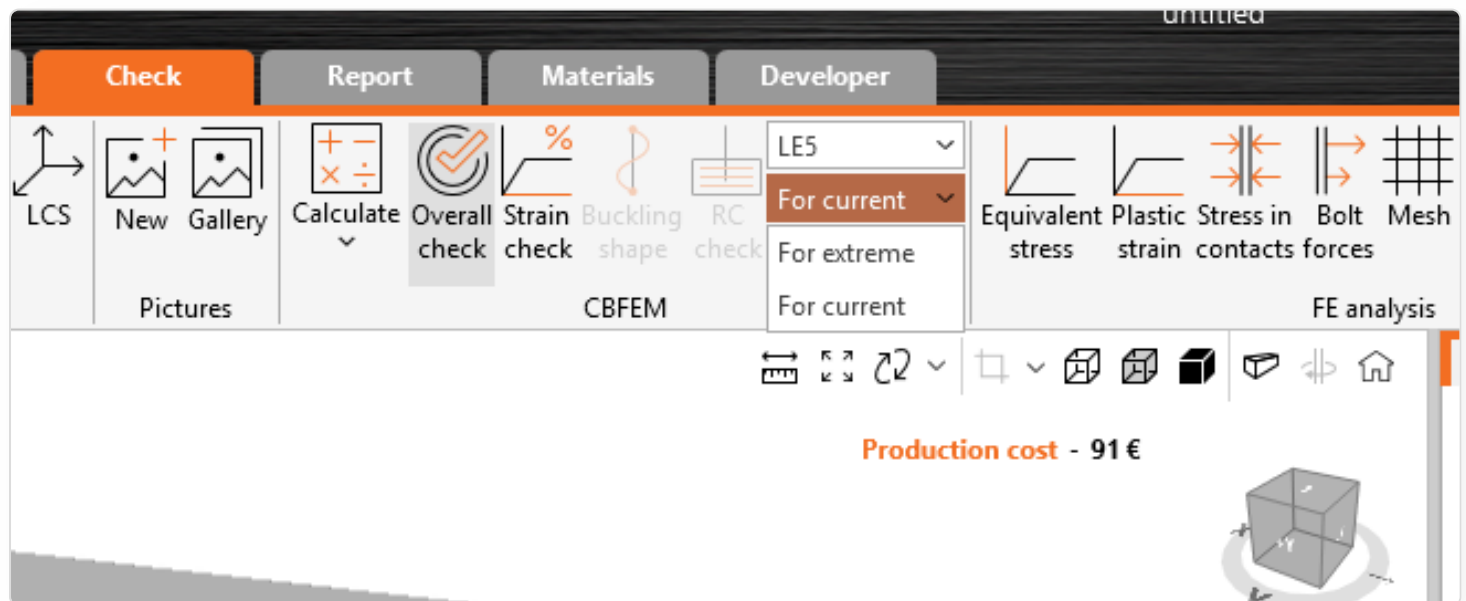

The calculated load effects are available directly in the tree in the 3D scene. Disabled load effects in the Design tab are not shown in the Check tab tree.

When the main **Load effects** header (or the **Stress, strain** item under) is selected, the results show a mix of all load effects, while for each connection part, there can be a different critical load effect. These results are shown:

- in brief results
- in the scene (stress maps)
- in the check tables

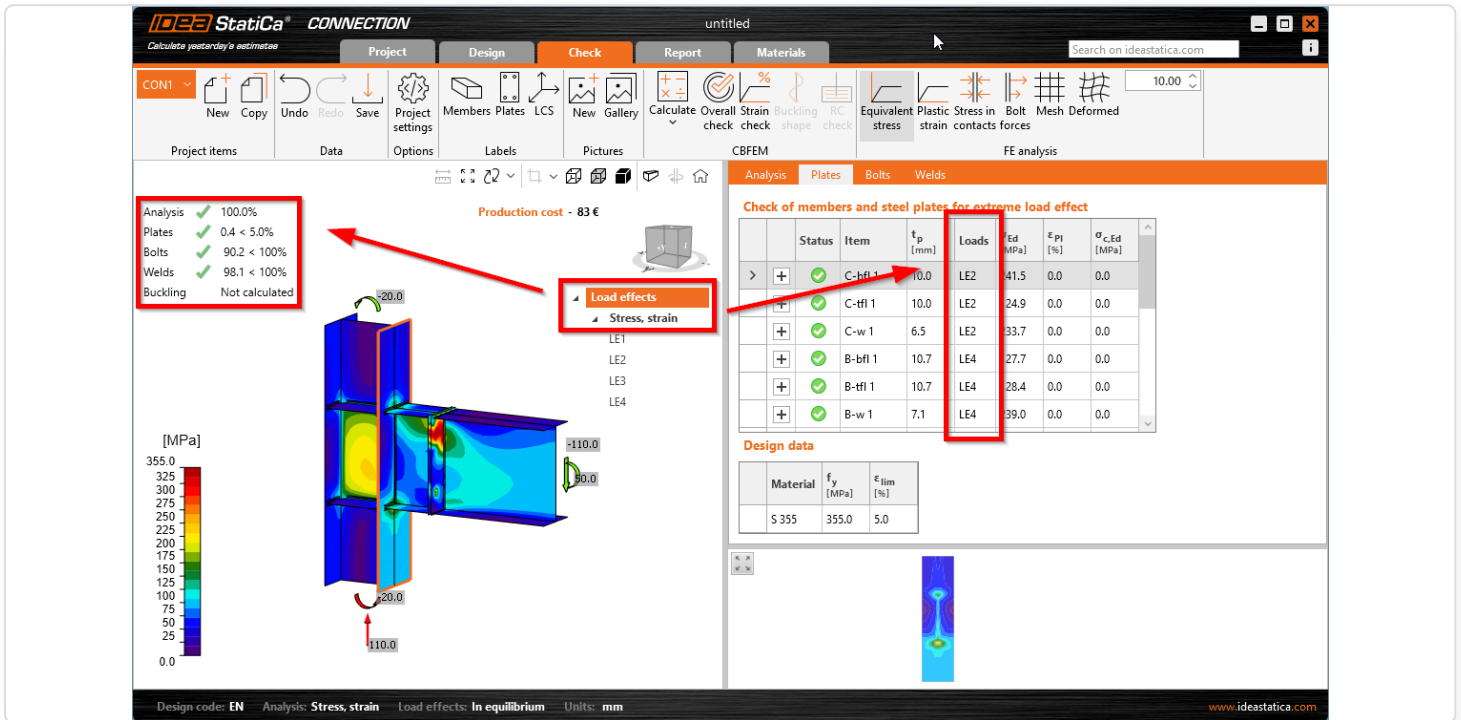

When a specific load effect is selected, results for this load only are shown everywhere – in the result overview, in the scene, and in tables.

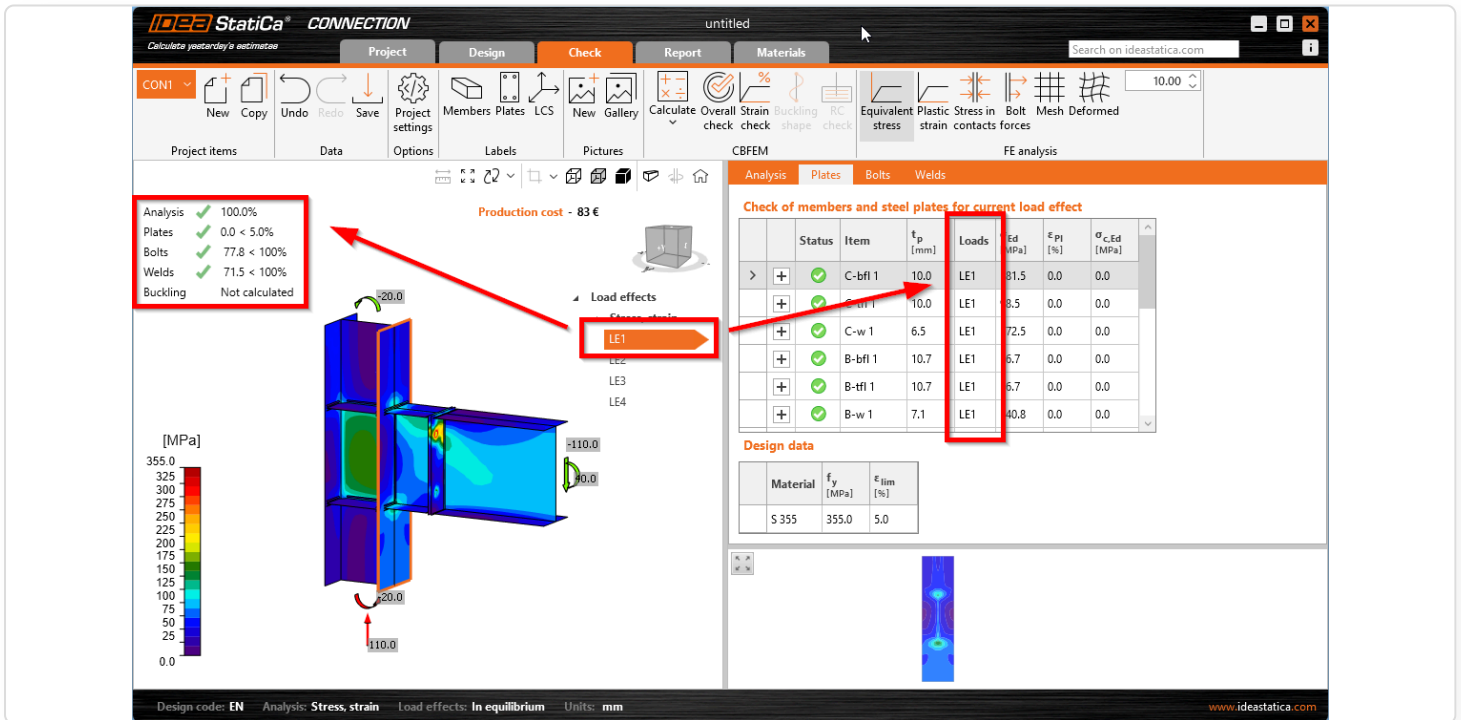

Improvements in report readability

The submission of a clear report is an essential part of a structural project's delivery. Good report readability in generated PDFs helps users submit their work without additional obstacles.

The report contains all necessary information for readers to fully understand the geometry, the design, and the results. Images in high quality with readable labels form a necessary part of this.

Improved pictures quality

In the report, the images have high quality (500x500 px) with sharp edges and better-displayed texts in figures so that everything is fully readable.

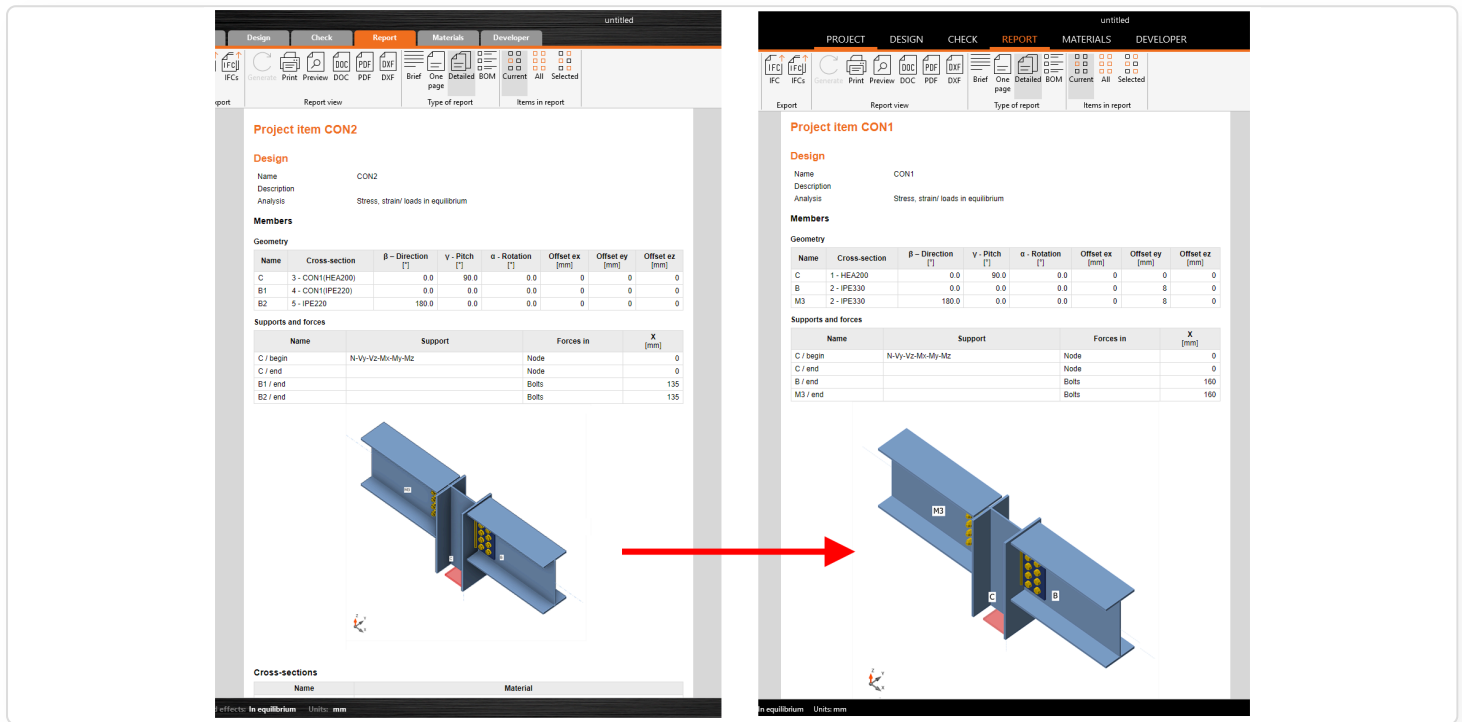

Larger pictures of plates and bolts

The small figure of bolted plates was replaced by a larger one so that in case of a higher amount of used bolts, the positions of all bolts are visible.

Bolts										Bolts													
Shape	Item	Grade	Loads	F _{Ed} [kN]	F _{vEd} [kN]	F _{d,Rd} [kN]	U _{t1} [%]	U _{t2} [%]	U _{t3s} [%]	Detailing	Status	Shape	Item	Grade	Loads	F _{Ed} [kN]	F _{vEd} [kN]	F _{d,Rd} [kN]	U _{t1} [%]	U _{t2} [%]	U _{t3s} [%]	Detailing	Status
	B1	M16 8.8 - 1	LE1	7.7	8.8	74.2	8.5	14.6	20.7	OK	OK		B1	M16 8.8 - 1	LE1	7.7	8.8	74.2	8.5	14.6	20.7	OK	OK
	B2	M16 8.8 - 1	LE1	0.3	8.6	74.2	0.4	14.3	14.6	OK	OK		B2	M16 8.8 - 1	LE1	0.3	8.6	74.2	0.4	14.3	14.6	OK	OK
	B3	M16 8.8 - 1	LE1	0.8	9.1	69.6	0.9	15.1	15.7	OK	OK		B3	M16 8.8 - 1	LE1	0.8	9.1	69.6	0.9	15.1	15.7	OK	OK
	B4	M16 8.8 - 1	LE1	0.2	8.7	69.6	0.3	14.5	14.7	OK	OK		B4	M16 8.8 - 1	LE1	0.2	8.7	69.6	0.2	14.5	14.7	OK	OK
	B5	M16 8.8 - 1	LE1	0.2	9.3	69.6	0.2	15.4	15.6	OK	OK		B5	M16 8.8 - 1	LE1	0.2	9.3	69.6	0.2	15.4	15.6	OK	OK
	B6	M16 8.8 - 1	LE1	0.1	8.8	69.6	0.2	14.6	14.8	OK	OK		B6	M16 8.8 - 1	LE1	0.1	8.8	69.6	0.2	14.6	14.7	OK	OK
	B7	M16 8.8 - 1	LE1	0.2	9.5	69.6	0.3	15.7	15.9	OK	OK		B7	M16 8.8 - 1	LE1	0.2	9.5	69.6	0.2	15.7	15.9	OK	OK
	B8	M16 8.8 - 1	LE1	0.1	8.8	69.6	0.2	14.7	14.8	OK	OK		B8	M16 8.8 - 1	LE1	0.1	8.8	69.6	0.1	14.7	14.8	OK	OK
	B9	M16 8.8 - 1	LE1	1.2	9.5	69.6	1.3	15.8	16.8	OK	OK		B9	M16 8.8 - 1	LE1	1.2	9.5	69.6	1.3	15.8	16.7	OK	OK
	B10	M16 8.8 - 1	LE1	2.3	8.8	69.6	2.6	14.6	16.5	OK	OK		B10	M16 8.8 - 1	LE1	2.3	8.8	69.6	2.5	14.7	16.5	OK	OK
	B11	M16 8.8 - 1	LE1	7.7	8.8	74.2	8.5	14.6	20.7	OK	OK		B11	M16 8.8 - 1	LE1	7.7	8.8	74.2	8.5	14.6	20.7	OK	OK
	B12	M16 8.8 - 1	LE1	0.3	8.6	74.2	0.4	14.3	14.6	OK	OK		B12	M16 8.8 - 1	LE1	0.3	8.6	74.2	0.3	14.3	14.5	OK	OK
	B13	M16 8.8 - 1	LE1	0.8	9.1	69.6	0.9	15.1	15.7	OK	OK		B13	M16 8.8 - 1	LE1	0.8	9.1	74.5	0.9	15.1	15.7	OK	OK
	B14	M16 8.8 - 1	LE1	0.2	8.7	69.6	0.3	14.5	14.7	OK	OK		B14	M16 8.8 - 1	LE1	0.2	8.7	74.5	0.3	14.5	14.7	OK	OK
	B15	M16 8.8 - 1	LE1	0.2	9.3	69.6	0.2	15.4	15.6	OK	OK		B15	M16 8.8 - 1	LE1	0.2	9.3	74.5	0.2	15.4	15.6	OK	OK
	B16	M16 8.8 - 1	LE1	0.2	8.8	69.6	0.2	14.6	14.8	OK	OK		B16	M16 8.8 - 1	LE1	0.2	8.8	74.5	0.2	14.6	14.8	OK	OK
	B17	M16 8.8 - 1	LE1	0.2	9.5	69.6	0.2	15.7	15.9	OK	OK		B17	M16 8.8 - 1	LE1	0.2	9.5	74.5	0.2	15.7	15.9	OK	OK
	B18	M16 8.8 - 1	LE1	0.2	8.8	69.6	0.2	14.7	14.8	OK	OK		B18	M16 8.8 - 1	LE1	0.2	8.8	74.5	0.2	14.7	14.8	OK	OK
	B19	M16 8.8 - 1	LE1	1.2	9.5	69.6	1.3	15.8	16.8	OK	OK		B19	M16 8.8 - 1	LE1	1.3	9.6	74.5	1.4	15.8	16.9	OK	OK
	B20	M16 8.8 - 1	LE1	2.3	8.8	69.6	2.5	14.7	16.5	OK	OK		B20	M16 8.8 - 1	LE1	2.3	8.8	74.5	2.5	14.6	16.5	OK	OK

PDF title

The title of the PDF document is changed from a general one "CombinedReportHeader.html", which is not specific and causes confusion in cases where more reports are opened. The new PDF title respects the name of the PDF file/project.

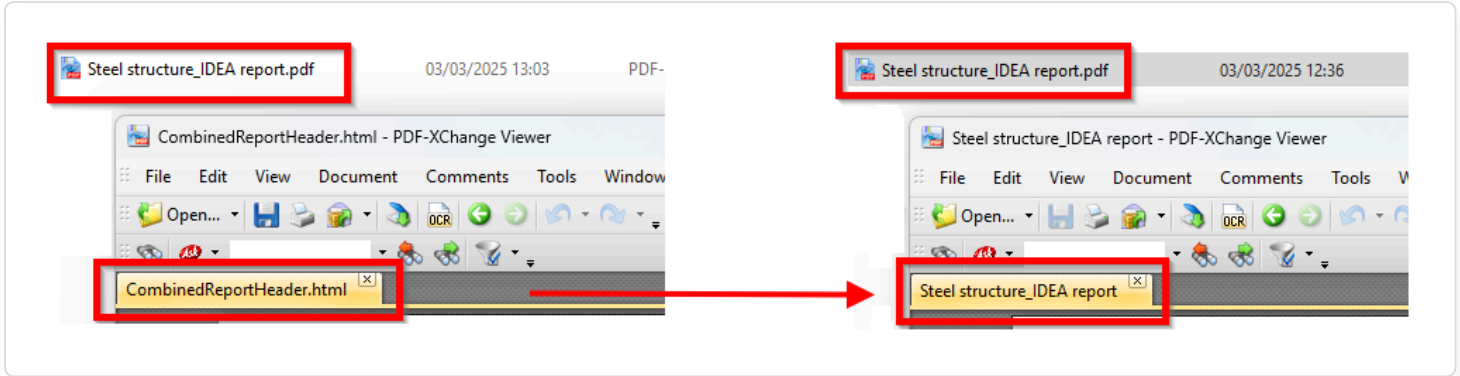

Direct link from Connection to Viewer

Sharing projects via Viewer is easier than ever – create the link from Connection directly and send it to anyone you need. Manage the shared links in Viewer under your account.

The top ribbon in IDEA StatiCa Connection has the possibility of sharing the project via our online [Viewer](#).

This is the easiest way to send the project to anyone, even to persons without an IDEA StatiCa license. No more sending large .ideacon files that need to be manually uploaded to Viewer.

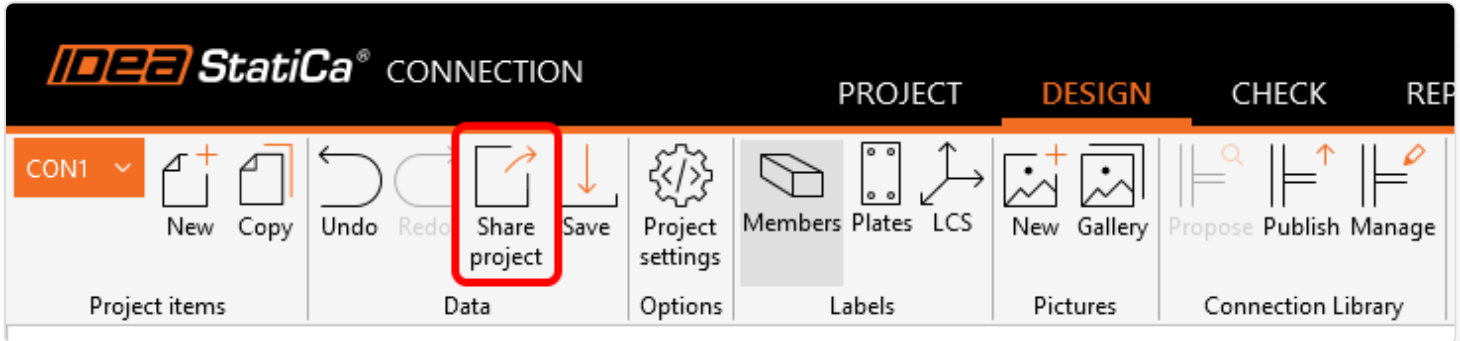

You can either copy the link onto the clipboard or open the project directly in [IDEA StatiCa Viewer](#).

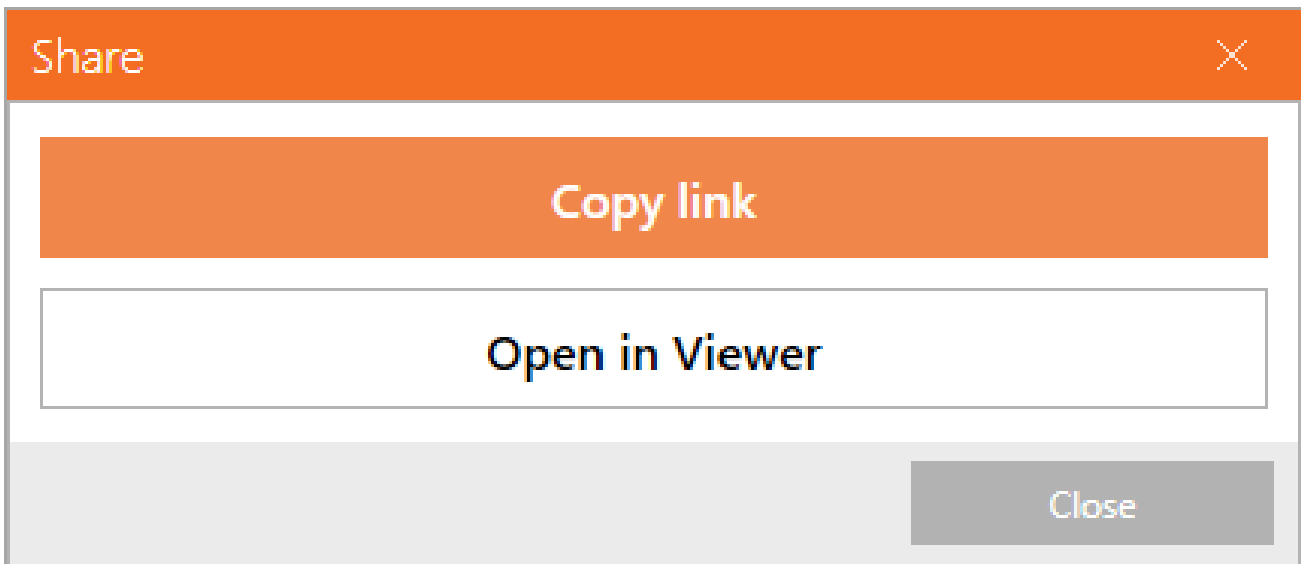

To open a shared project, you do not need to have an IDEA StatiCa license. However, to interact with the project in Viewer, you need to use your commercial, trial, or educational, or register for the free [IDEA StatiCa Basic account](#).

Link management

When logged in to [your user account](#), you can find all your links to Viewer models, both the ones created and owned by you as well as the ones shared with you.

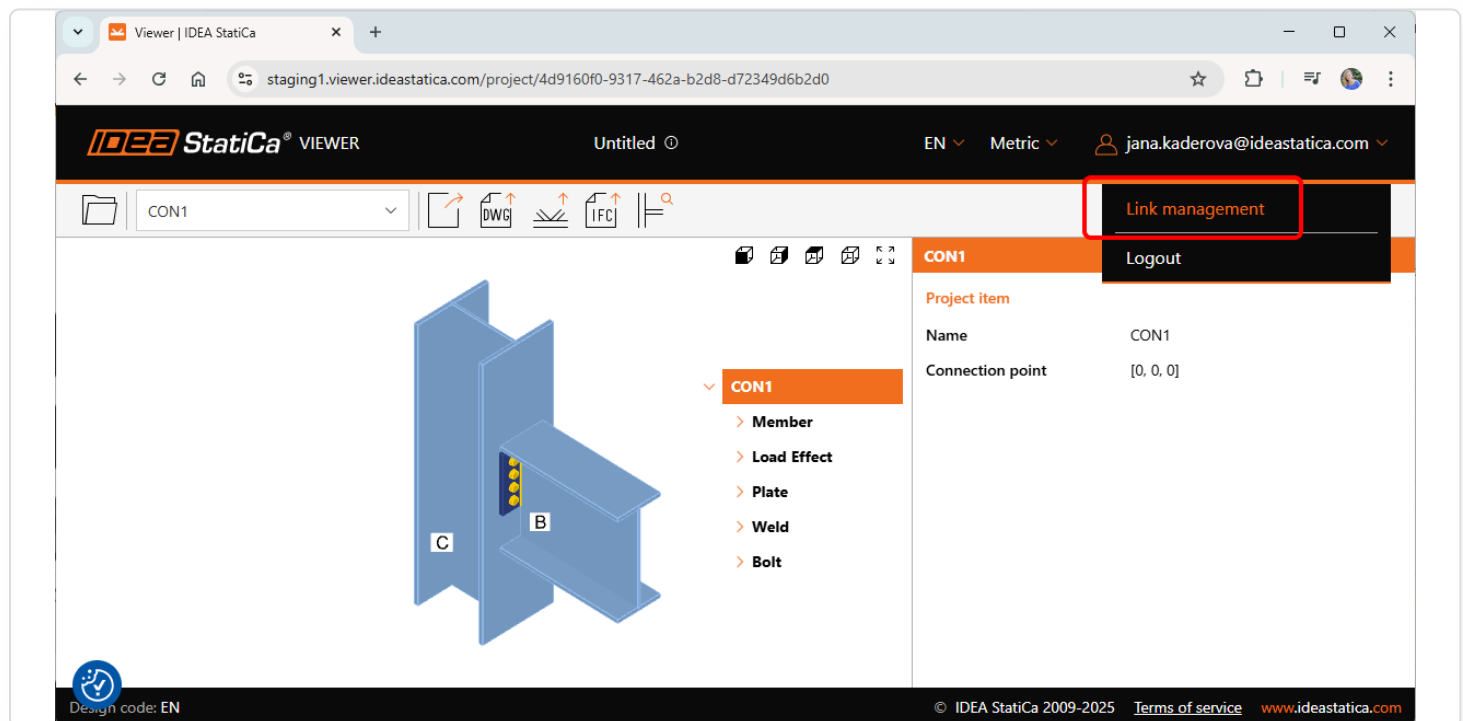

Each project with a generated link is saved on the cloud server and the URL can be copied and sent again. Projects can also be deleted from the list.

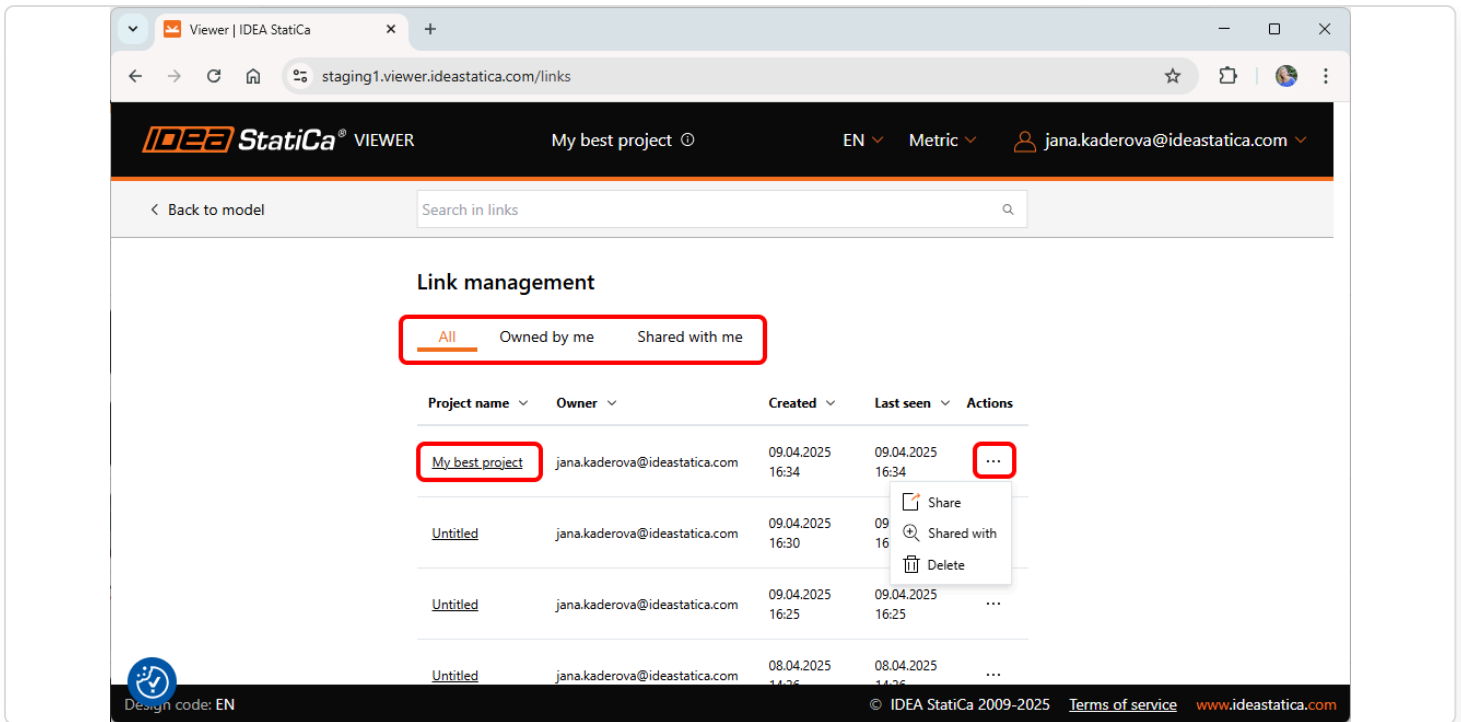
**Note:**

- All project items of the shared file are added to the Viewer (whole project), users can't choose only one project item.
- Shared projects are excluded from Viewer product analytics by default.
-

Regional improvements in 25.0

For local engineers, version 25.0 offers several improvements like PJP welds in Eurocode, implementation of the new ACI and not just for US engineers, anchoring checks for Chinese standard, differentiation of UK and US terminology, and more.

The major regional improvements of version 25.0 are:

[PJP welds for Eurocode \(EN\)](#)

[Implementation of ACI 318-19 into steel apps](#)

[UK and US English](#)

[Update of AISC-341 MPRL](#)

[CSA S16:19 weld update](#)

[Anchoring checks for the Chinese code \(GB\)](#)

[Theoretical Background for AISC in Brazilian Portuguese](#)

PJP welds for Eurocode (EN)

Partial joint penetration butt welds (PJP) are very often used in situations when the design asks for a smooth geometry, e.g., end plates used for tubular cross-sections in architecture-sensitive structures. **Butt welds** are not cost-effective, so partial penetration joints are a good choice.

In dedicated operations, the PJP welds can be selected from the drop-down menu.

Welds

Flanges [mm] 4.0 S 355 +

Webs [mm] 4.0 Automatic +

- Fillet weld - front side
- Fillet weld - rear side
- Double fillet weld
- CJP weld
- PJP weld**
- No weld

In the Results tab, the PJP welds are depicted using a special symbol.

Production cost - 7 €

Load effects
Stress, strain
LE1

Analysis Plates Welds

Check of welds for extreme load effect

Status	Item	Edge	Th [mm]	L [mm]	Loads	$\sigma_{w,Ed}$ [MPa]	ϵ_{pl} [%]	σ_{\perp} [MPa]	τ_{\perp} [MPa]	τ_{\parallel} [MPa]	Ut [%]	Ut _c [%]	Detailing	
✓	M1-bfl 1	M2-bfl 1	4.5.7	299	LE1	24.3	0.0	-0.8	-14.0	-1.0	5.6	5.6	✓	
<p>Weld resistance check (EN 1993-1-8 – Cl. 4.5.3.2)</p> $\sigma_{w,Rd} = f_u / (\beta_w \gamma_{M2}) = 435.6 \text{ MPa} \geq \sigma_{w,Ed} = [\sigma_{\perp}^2 + 3(\tau_{\perp}^2 + \tau_{\parallel}^2)]^{0.5} = 24.3 \text{ MPa}$ $\sigma_{\perp,Rd} = 0.9 f_u / \gamma_{M2} = 352.8 \text{ MPa} \geq \sigma_{\perp} = 16.3 \text{ MPa}$ <p>where:</p> <ul style="list-style-type: none"> $f_u = 490.0 \text{ MPa}$ – Ultimate strength $\beta_w = 0.90$ – Correlation factor EN 1993-1-8 – Tab. 4.1 $\gamma_{M2} = 1.25$ – Safety factor 														
+	✓	M1-tfl 1	M3-bfl 1	▲ 5.0 ▽	299	LE1	260.3	0.0	128.2	130.2	-12.4	59.8	44.0	✓
+	✓			▲ 5.0 ▽	299	LE1	257.7	0.0	-126.9	128.9	-12.1	59.2	43.9	✓

PJP welds are not included in Autodesign of welds.

PJP welds are supported by other standards as well.

Implementation of ACI 318-19 into Steel apps

The latest version of ACI (ACI 318-19) is now implemented in the Connection application. The user can easily choose which version of AISC and which version of ACI will be used in the project and can change it anytime while working in the model.

You can choose which version of steel code and which version of concrete code will be used in the new project in the wizard. It can be combined according to your preferences:

General

Name	<input style="width: 90%;" type="text"/>
Description	<input style="width: 90%;" type="text"/>
Design code	v
Steel code edition	AISC 360-16 (LRFD) v
Concrete code edition	ACI 318-19 v
	<div style="border: 1px solid #ccc; padding: 5px; margin-bottom: 5px;">ACI 318-19</div> <div style="border: 1px solid #ccc; padding: 5px;">ACI 318-14</div>

When the model is already created, the code version can be easily changed in the project info dialog:

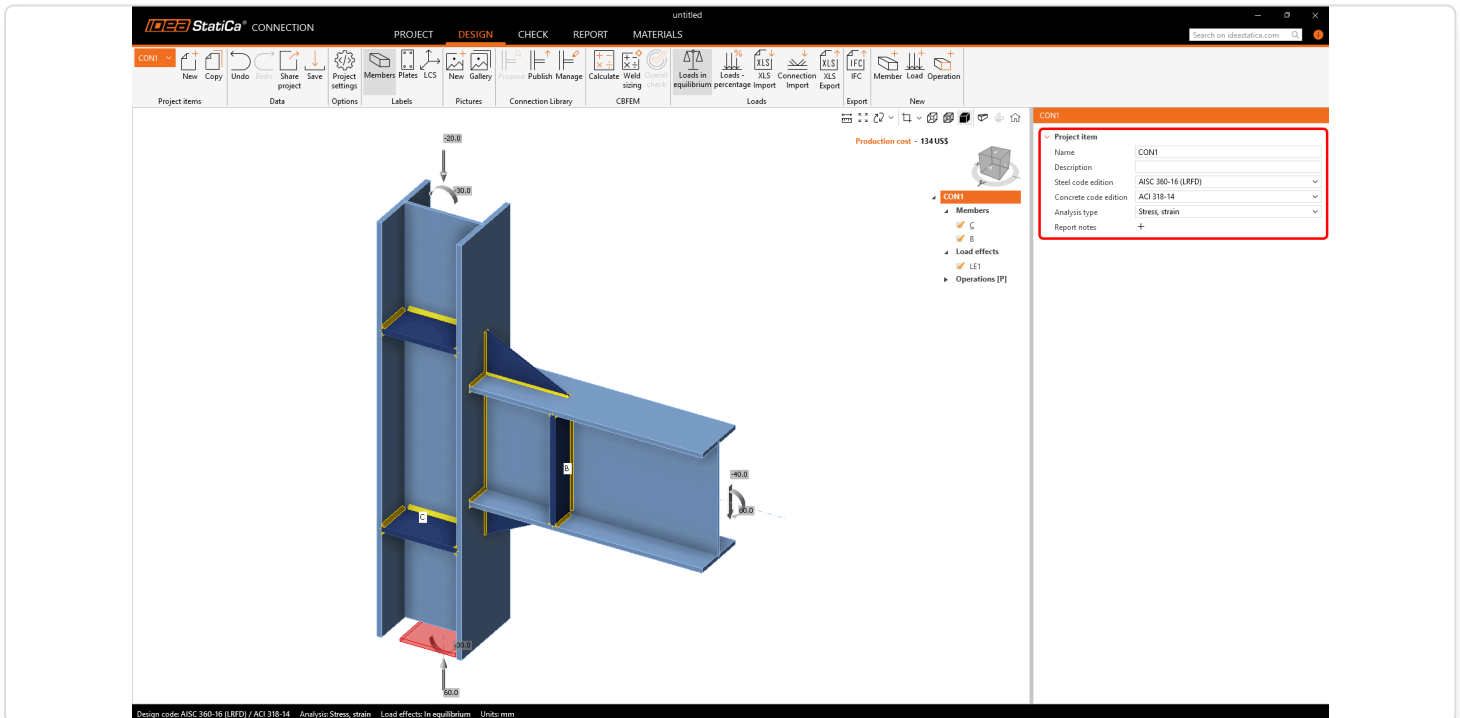

The code references to the selected code version are then used in the report.

Detailed result for A3

Anchor tensile resistance (ACI 318-19 – 17.6.1)

$$\phi N_{sa} = \phi \cdot A_{se,N} \cdot f_{uta} = 84.4 \text{ kN} \geq N_f = 0.0 \text{ kN}$$

Where:

$$\phi = 0.70 \quad \text{– resistance factor}$$

$$A_{se,N} = 146 \text{ mm}^2 \quad \text{– tensile stress area}$$

$$f_{uta} = 827.4 \text{ MPa} \quad \text{– specified tensile strength of anchor steel:}$$

The same options are available in [IDEA StatiCa Checkbot](#).

The currently implemented codes for AISC users:

AISC

- AISC 360-10 / 360-16 / 360-22 (LRFD)
- AISC 360-10 / 360-16 / 360-22 (ASD)

ACI

- ACI 318-14 / ACI 318-19

Released in IDEA StatiCa version 25.0.

UK and US English

The terminology used in IDEA StatiCa Connection that is familiar to your regional language makes the adoption and usability of the software much easier and enjoyable.

The original English language was renamed to English (US) and a new version of English (UK) was added. English (US) is used as default. You can change your local language in [Preferences](#).

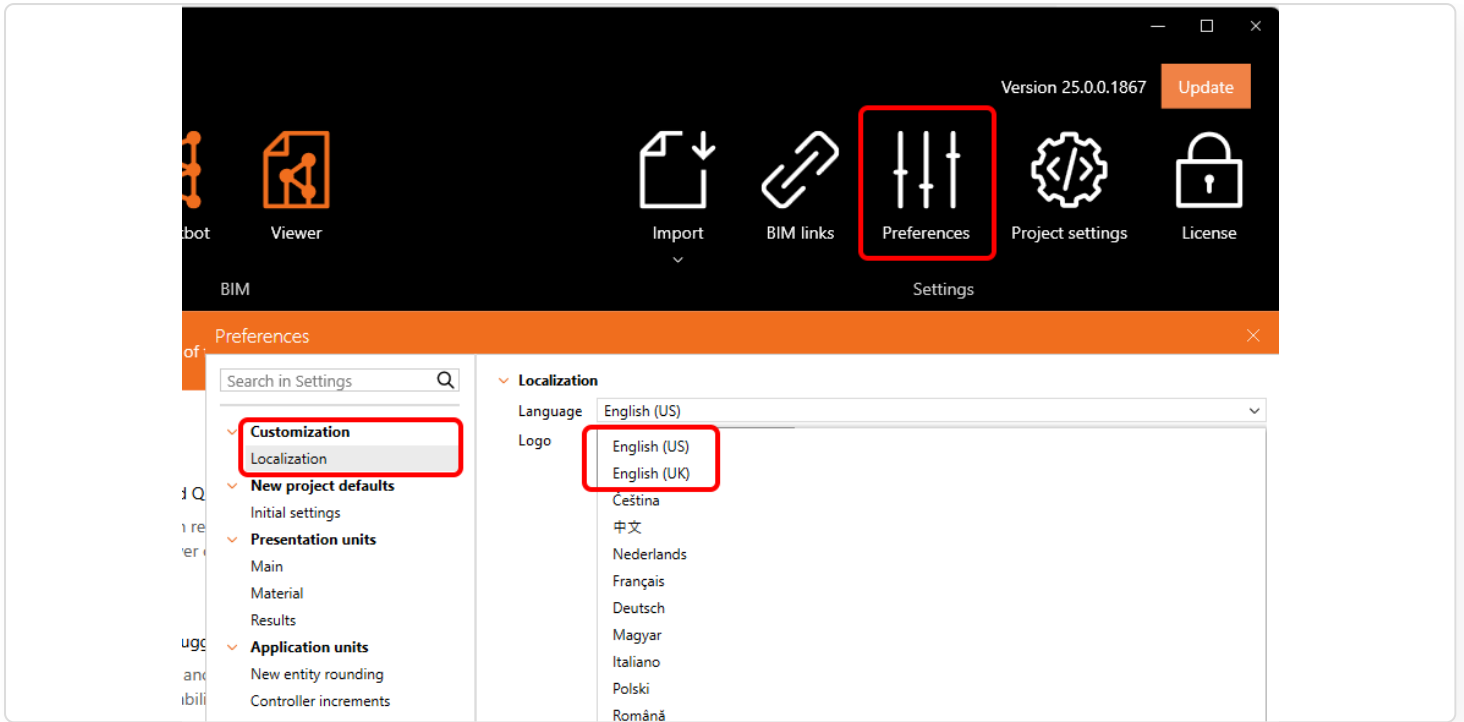

According to the set language, the proper terms of the different manufacturing operations are presented in the model.

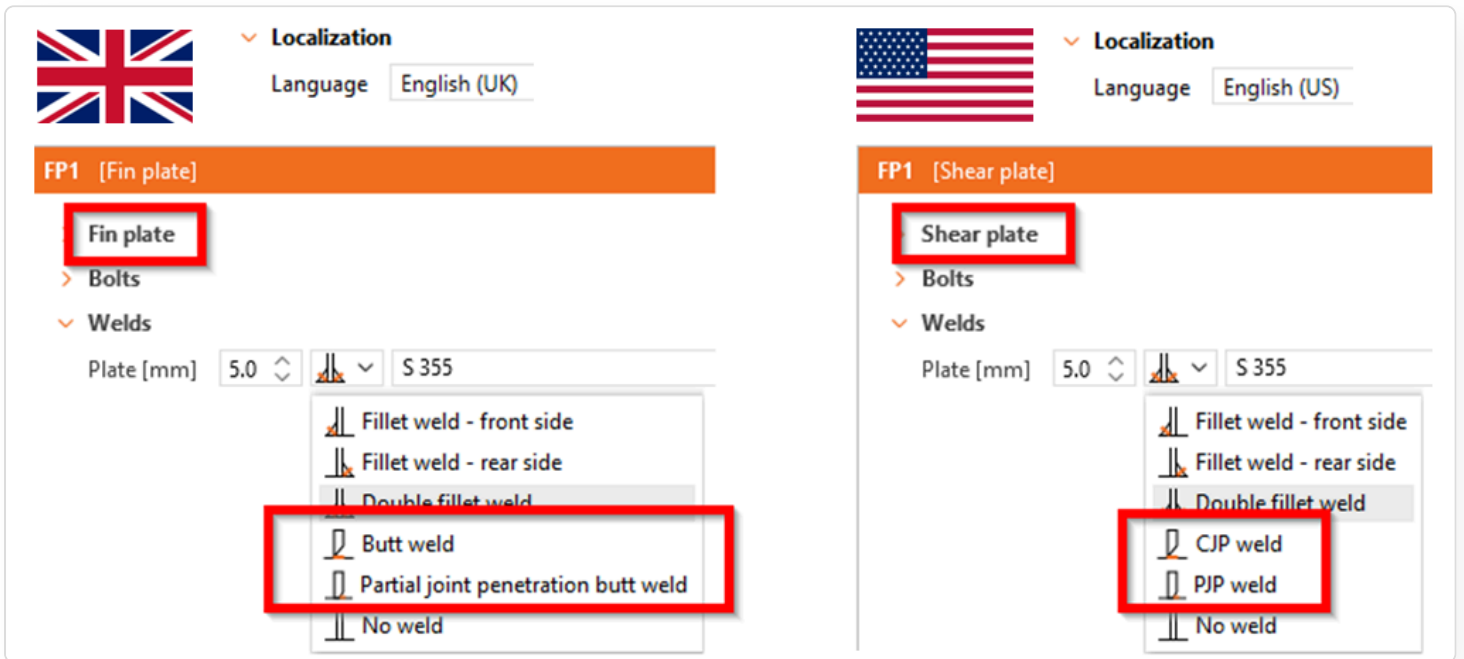

Released in IDEA StatiCa version 25.0.

Update of AISC-341 MPRL

Minor modifications of the differences in R_y and R_t , which are used in capacity design for dissipative items, were introduced.

Released in IDEA StatiCa version 24.1.3.

CSA S16:19 weld update

An update was introduced for the weld check according to the Canadian standard: No directional strength increase for a single-sided fillet weld is considered in the weld check.

When a single-sided fillet weld is selected and connected plates are not parallel (with small tolerance), the directional strength increase is not applied.

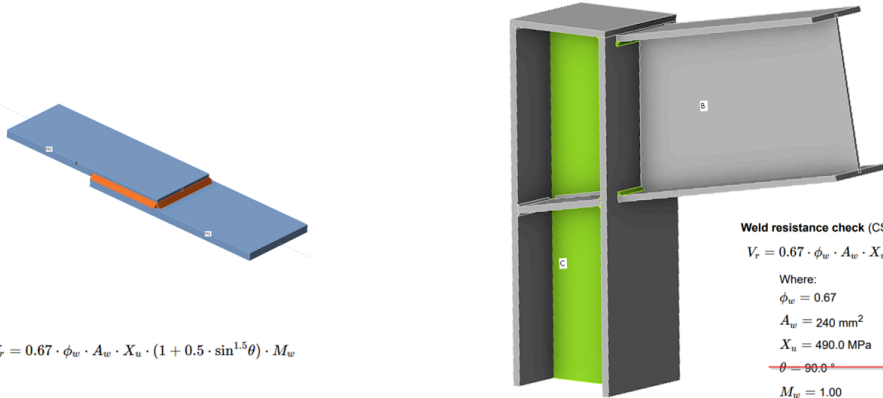

Weld resistance check (CSA S16:19 – 13.13.2.2)

$$V_r = 0.67 \cdot \phi_w \cdot A_w \cdot X_u \cdot (1 + 0.5 \cdot \sin^{1.5}\theta) \cdot M_w = 79.2 \text{ kN} \geq F_w = 60.8 \text{ kN}$$

Where:

- $\phi_w = 0.67$ – resistance factor for welded connections
- $A_w = 240 \text{ mm}^2$ – effective throat area of weld critical element
- $X_u = 490.0 \text{ MPa}$ – ultimate strength as rated by the electrode classification number
- $\theta = 90.0^\circ$ – angle of axis of weld segment with respect to the line of action of applied force
- $M_w = 1.00$ – strength reduction factor for multi-orientation fillet welds:
 - $M_w = 1.0$ – for joints with a single weld orientation
 - $M_w = \frac{0.85 + \theta_1/600}{0.85 + \theta_2/600}$ – for joints with multiple weld orientations, for each segment, where:
 - θ_1 – orientation of the weld segment under consideration
 - θ_2 – orientation of the weld segment in the joint that is nearest to 90°

This also affects the calculation of weld strength for Autodesign of welds and applies to all code versions of CSA (also S16-14).

Released in IDEA StatiCa version 25.0.

Anchoring checks for the Chinese code (GB)

Anchoring is the second most calculated type of design in the Connection app. The Chinese national standard (GB) was implemented in IDEA StatiCa Connection so that also users following the GB code can calculate projects with all relevant code checks.

Available types of stand-off between the base plate and the foundation block:

- direct
- mortar
- gap

In **Project settings**, the **code factors** can be defined:

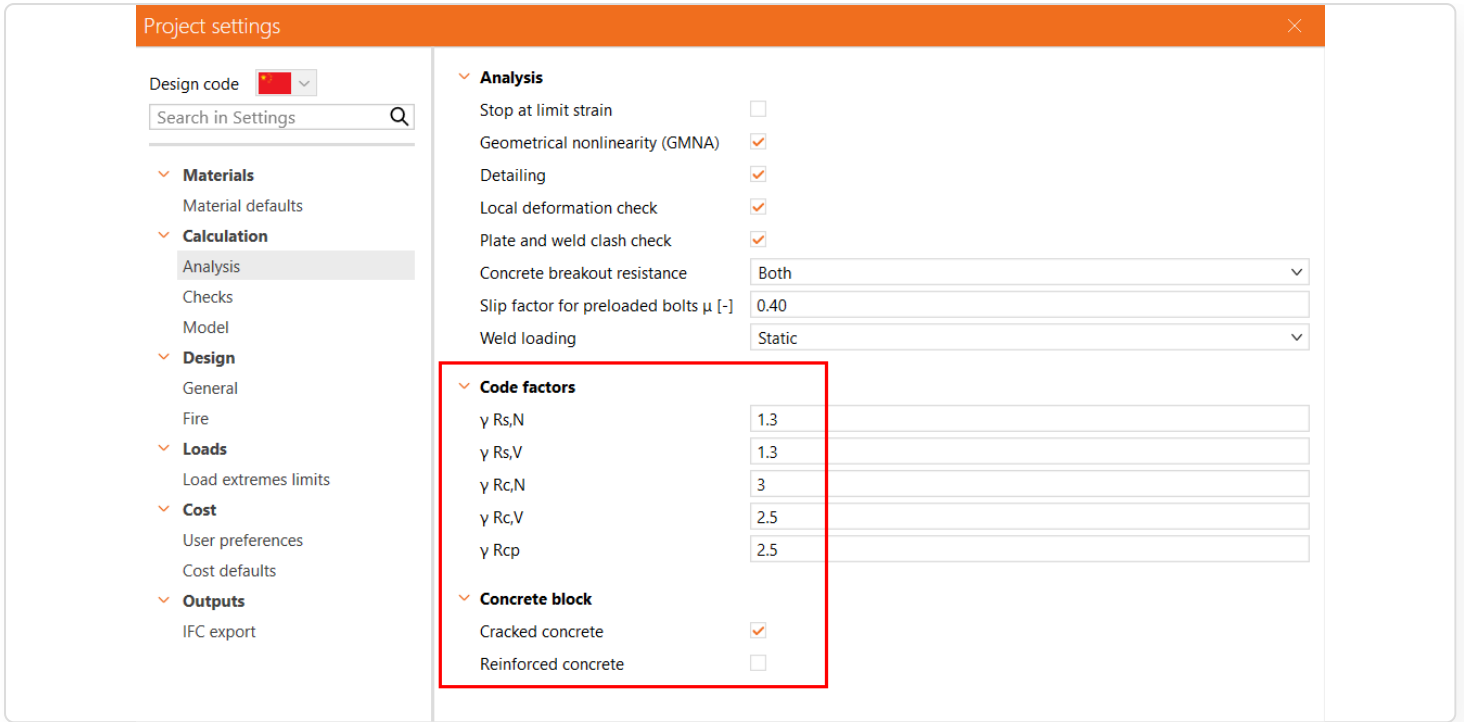

The specific checks are presented in the table under the Check tab, and in the Report.

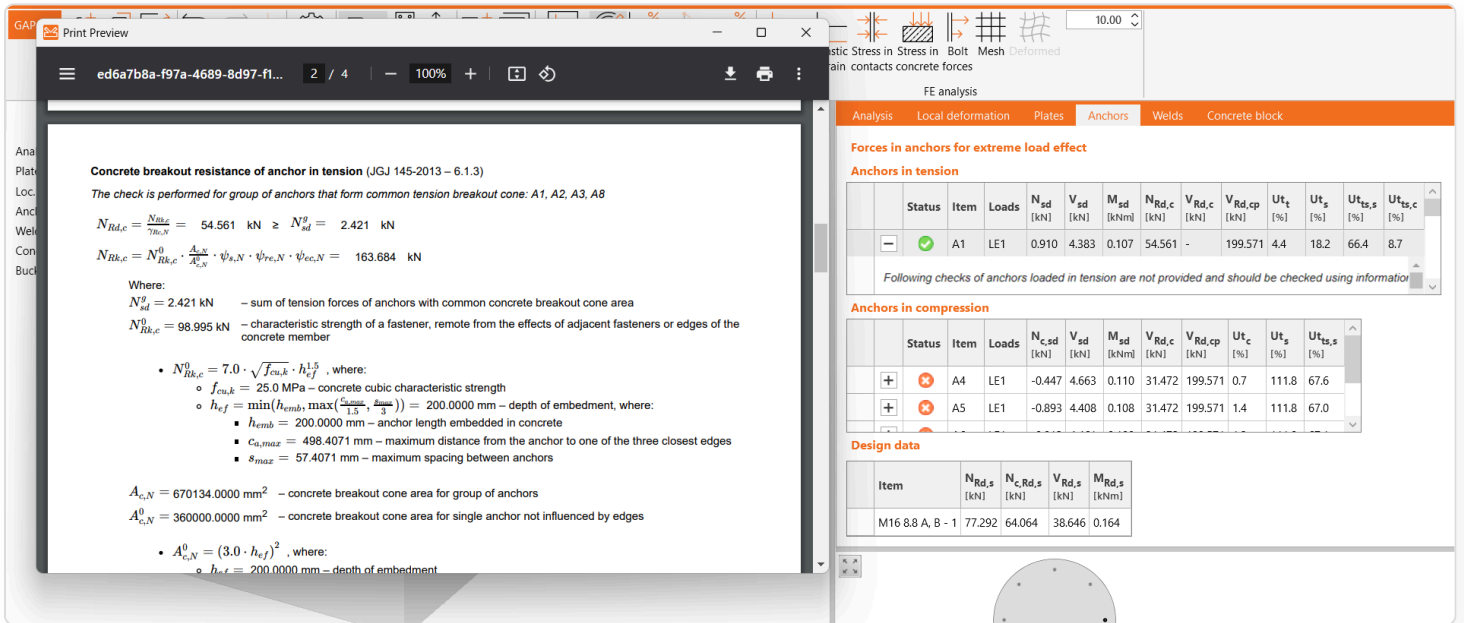

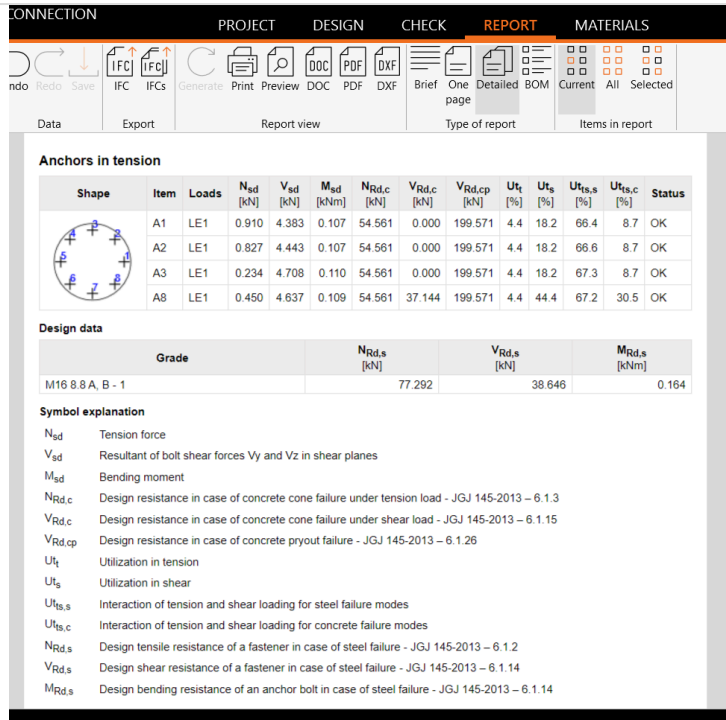

Released in IDEA StatiCa version 25.0.

Theoretical Background for AISC in Brazilian Portuguese

Specific language translation of the Theoretical Background was added for Brazilian Portuguese (BR). This document can be included in the Report in IDEA StatiCa Connection.

It is possible to change the Report language only. Find out more in [Change just the language of the report.](#)

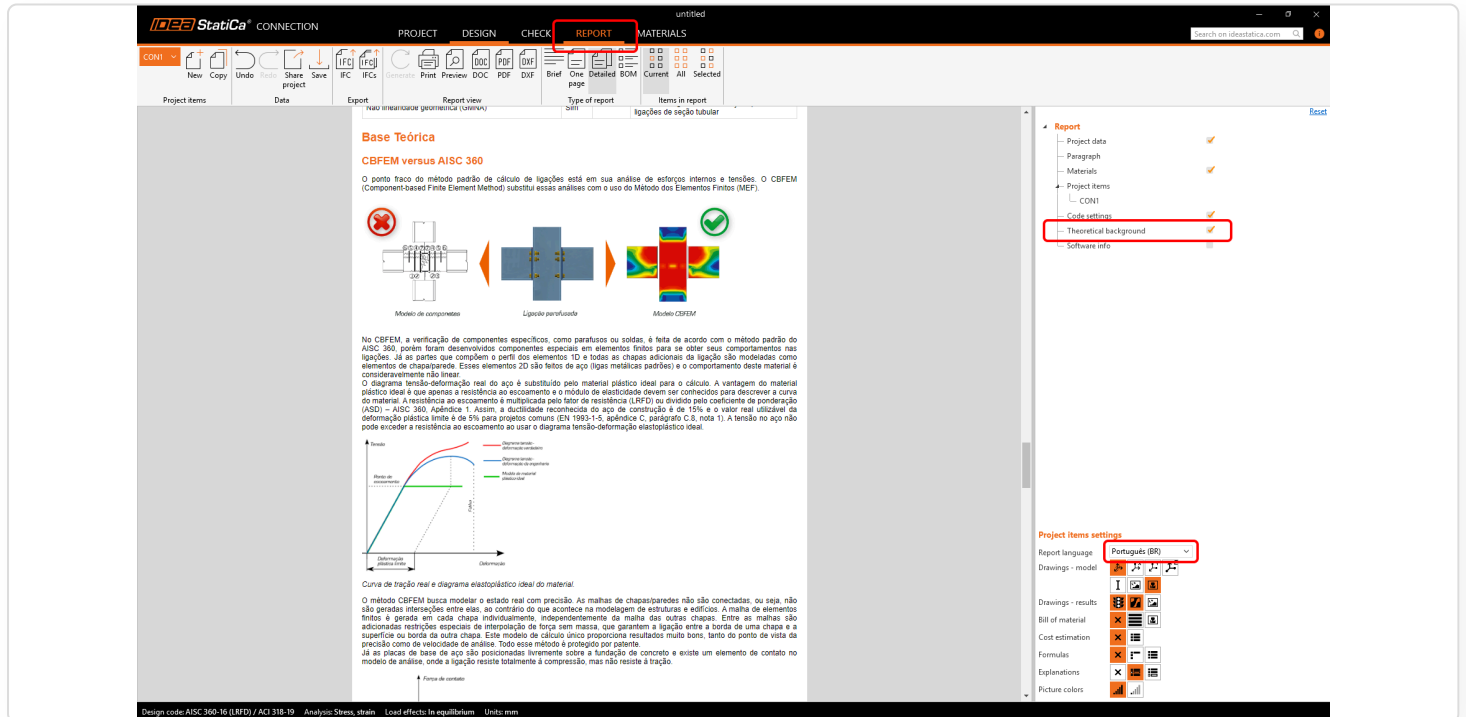

Released in IDEA StatiCa version 24.1.1.

Member wizard models available for AISC and AS

The Member app now offers wizard models tailored to all supported codes (including AISC and AS), enabling users to generate code-specific templates with accurate materials, cross-sections, and fasteners.

The latest enhancement in the Member application introduces wizard-generated models tailored to the user's selected design code. Whether working under EN, AISC, or another supported standard, users can now generate complete model templates with code-specific materials, cross-sections, and connection components.

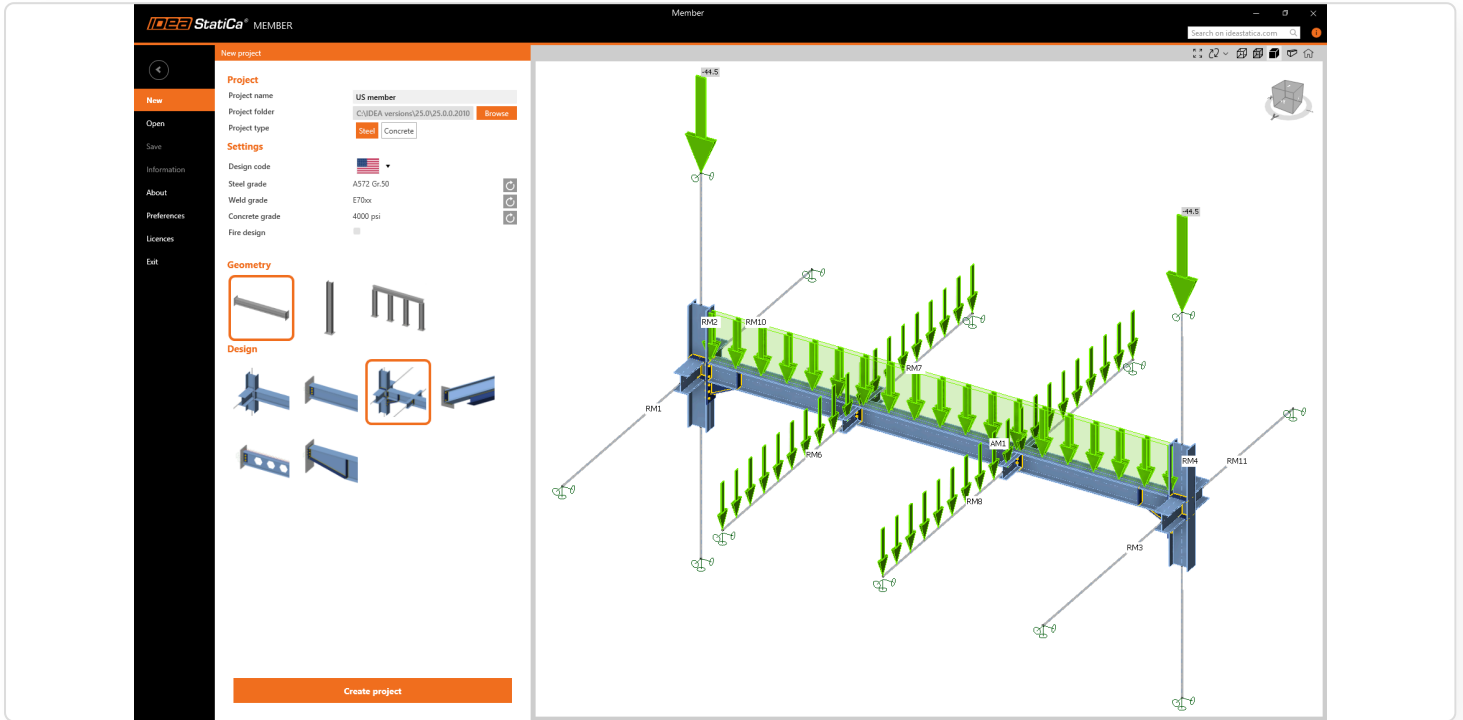

This removes the limitation where only EN-based examples are available, making the app intuitive and accessible across global markets.

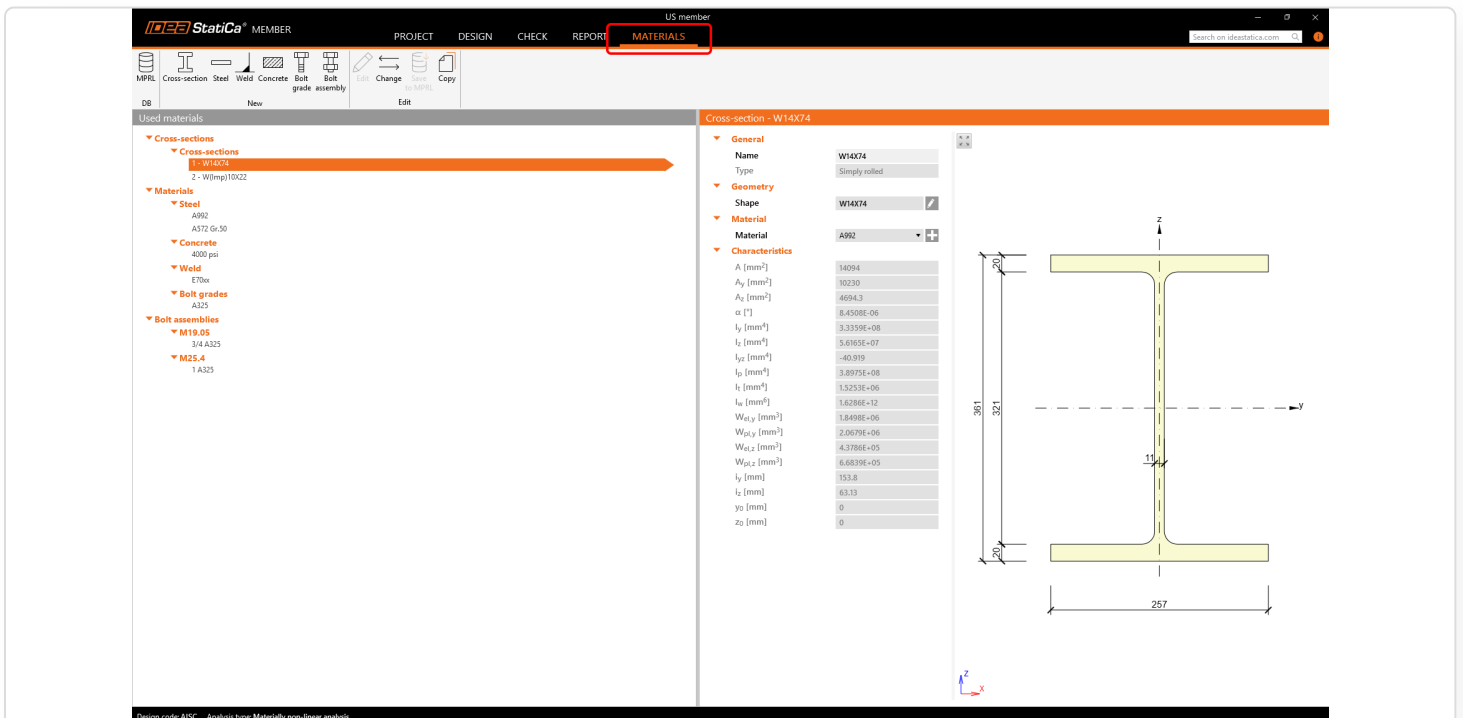

Released in IDEA StatiCa version 24.1.2.

BIM and Checkbot

Bulk workflows and critical load filter in Checkbot

The Checkbot app is ready to handle big projects in no time. Its ability to perform bulk actions, such as designing connections in a group with one report generation for the whole project or identifying critical load effects, makes it the most effective tool for designing standard connections.

Bulk report for all connections in Checkbot

The **Report** tab is available in Checkbot in the same format as in the Connection app. The report can be generated for all connections in the project at once or for selected connections only and can be saved in PDF or DOC format for further editing or can be printed out.

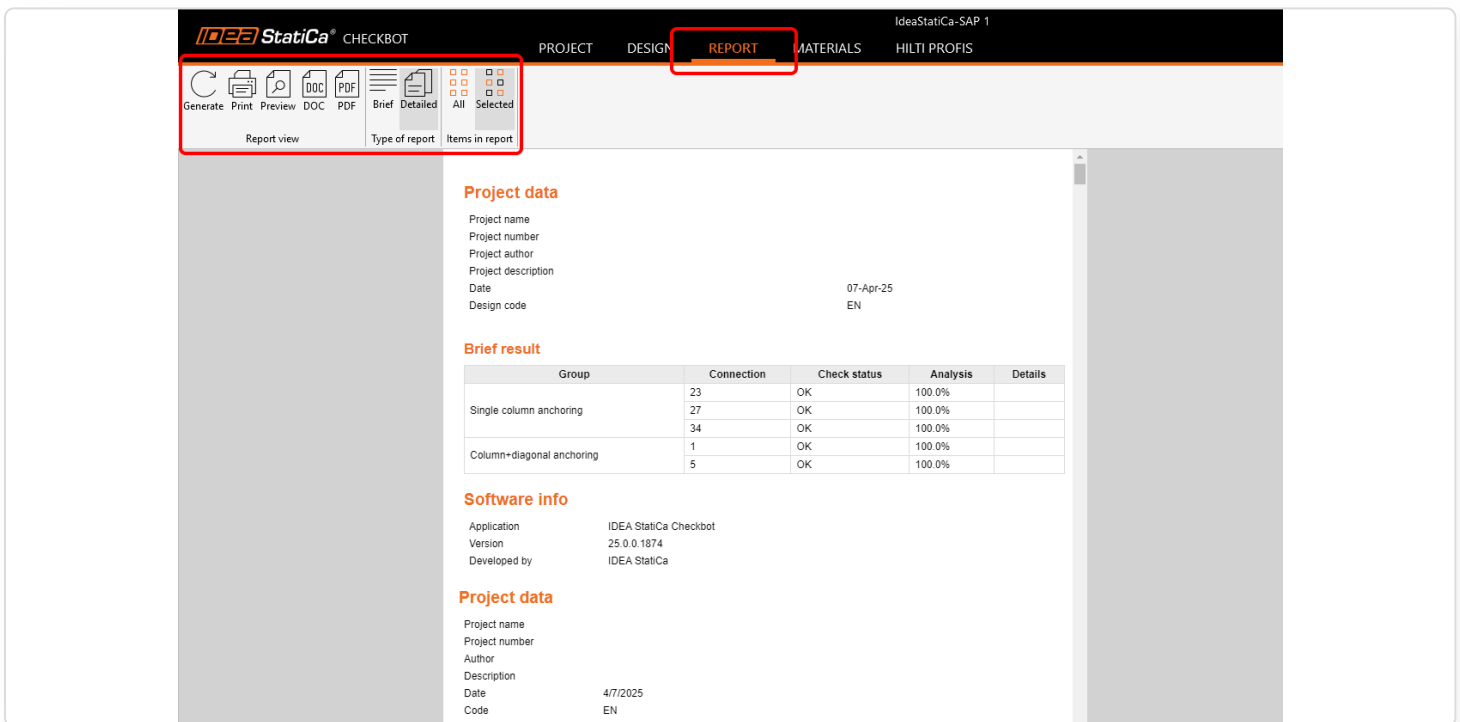

Types of report

If **All** is chosen in the **Report** tab, the report contains all connections from the Checkbot project.

If **Selected** is chosen in the **Report** tab, the report will contain only the connections selected in the **Design** tab in the tree list of items in the Checkbot project.

The **Brief** type of report is a one-pager that includes the project Information (defined in the backstage menu), the brief results tab, and the software information.

Project data

Project name	Example
Project number	01
Project author	Ida Staticon
Project description	Steel hall
Date	07-Apr-25
Design code	EN

Brief result

Group	Connection	Check status	Analysis	Details
Arrangement 1-1	N220	Not OK!	100.0%	Welds Detailing
Top chord - Corners	N215	OK	100.0%	
	N227	OK	100.0%	
Bottom chord	N216	OK	100.0%	
	N218	OK	100.0%	
Top chord	N217	OK	100.0%	
	N219	OK	100.0%	
	N223	OK	100.0%	
	N225	OK	100.0%	
Bottom chord - mirrored	N222	OK	100.0%	
	N224	OK	100.0%	
Arrangement 4-1	N214	OK	100.0%	
Arrangement 5-1	N226	Not OK!	100.0%	Plates 6.3 > 5.0% Welds 103.6 > 100%
Arrangement 6-1	N221	OK	100.0%	

Software info

Application	IDEA StatiCa Checkbot
Version	25.0.0.1268
Developed by	IDEA StatiCa

The **Detailed** type of report includes the brief report part first (project information, brief results tab, software information) and a composition of reports for each connection.

Settings for each connection report used for the **Detailed** Checkbot report can be set by opening each connection from Checkbot and navigating to the Report tab.

When the **Generate** command is used, Checkbot calculates all the non-calculated connections, and the **Detailed** connection report is composed from the single connection reports one by one.

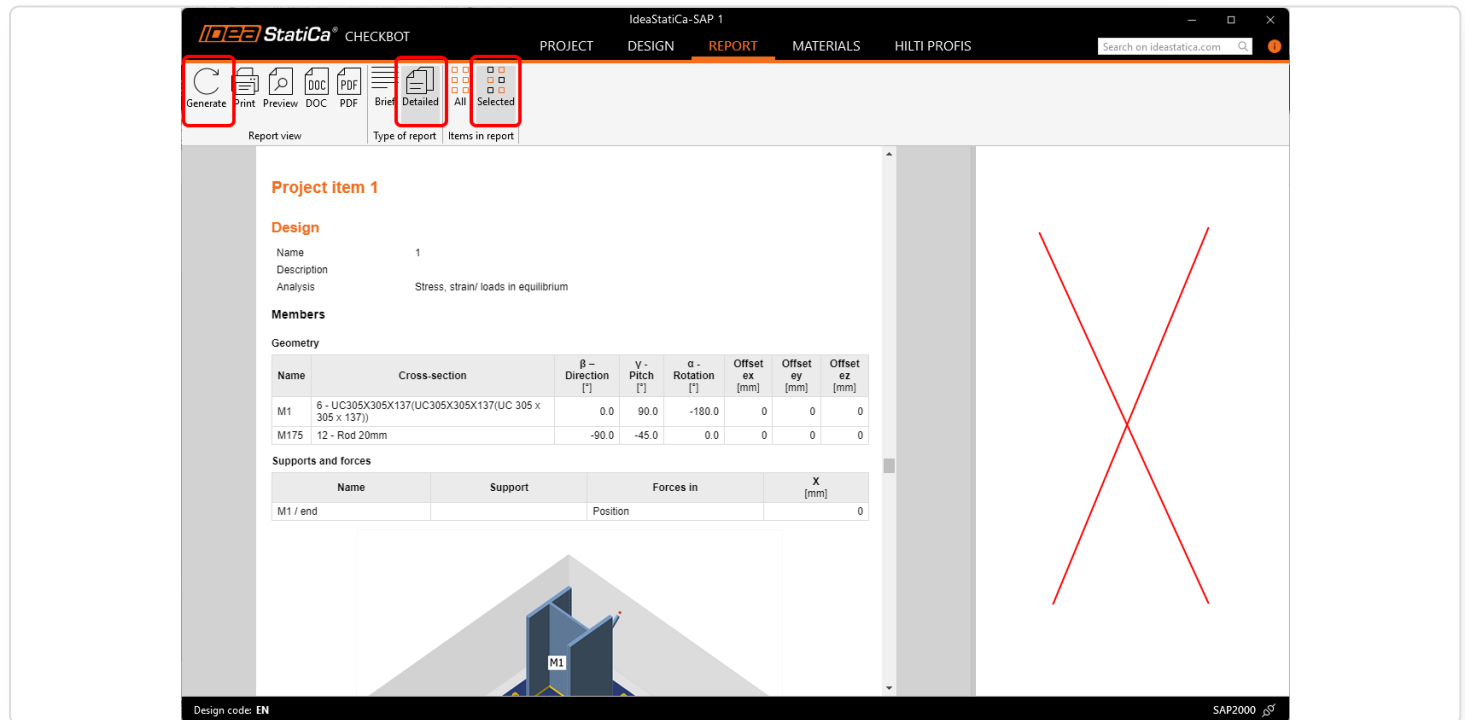

Note: Report settings that are functional in the Connection app, such as adding pictures or code equations, are not yet available directly in Checkbot and must be set for each connection report individually.

Calculate load extremes for all connections

In projects with many nodes and load combinations, similar connections with very similar load effects are analyzed repeatedly. To effectively reduce the calculation time, the **Calculate load extremes** algorithm identifies critical load combinations in a defined group of connections and speeds up the calculation time by up to 80%.

This function, together with the bulk group actions in Checkbot, enables users to design all connections in a project with minimum time. After that, users can deactivate the function and calculate all connections with all load effects as the final check.

The Calculate load extremes functionality is available only for Checkbot projects imported from FEA models, since CAD models usually don't contain any load effects.

How to use the Calculate load extremes function

Calculate load extremes represents the Checkbot bulk variant of the function **Calculate load extremes**, which is available for single connections in the Connection app.









First, for an automatically or manually created group of connections, design the reference connection.

Then select the group and tick the **Calculate load extremes** combo box. This runs the algorithm, and a tab appears showing only connections containing the critical load effects.

The screenshot displays the software interface for configuring the 'Calculate load extremes' function. On the left, a tree view shows a hierarchy of connections: Arrangement 1-1 (Group 1), Arrangement 2-1 (Group 2), and Arrangement 2-2 (Group 3). 'Group 1' is selected and highlighted with a red box. The main panel shows the configuration for 'Group 1' with the following settings:

- General:** Name: Group 1; Reference connection: 23; Reference design applied to group: Yes; Number of connections: 6.
- Typology:** Number of members: 1.
- Loads:** Result classes for checks: Reference connection; Calculate load extremes: ; Critical connections: 4; Load sub-groups: 1.

Below the settings is a table showing the results of the calculation:

	Load sub-group	Critical connection	Critical load effects	
>	[1]	34	3	 
	[1]	38	3	 
	[1]	45	4	 
	[1]	49	4	 

In the screenshot, red boxes highlight 'Group 1' in the tree, the 'Calculate load extremes' checkbox, the 'Critical connection' column in the table, and the 'Critical load effects' column in the table.

Now, only the critical load effects detected in the several connections where they were detected can be calculated. All other load effects in this group are disabled (for some connections, all load effects are disabled).

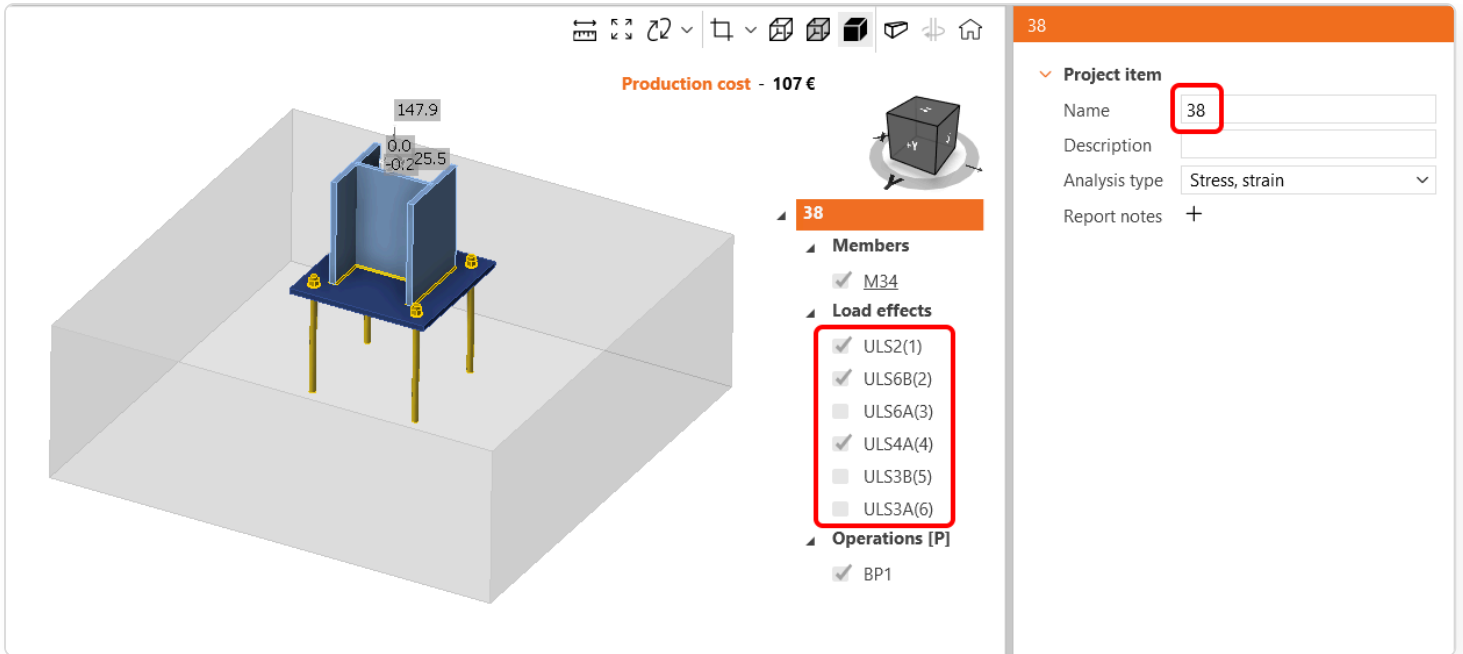



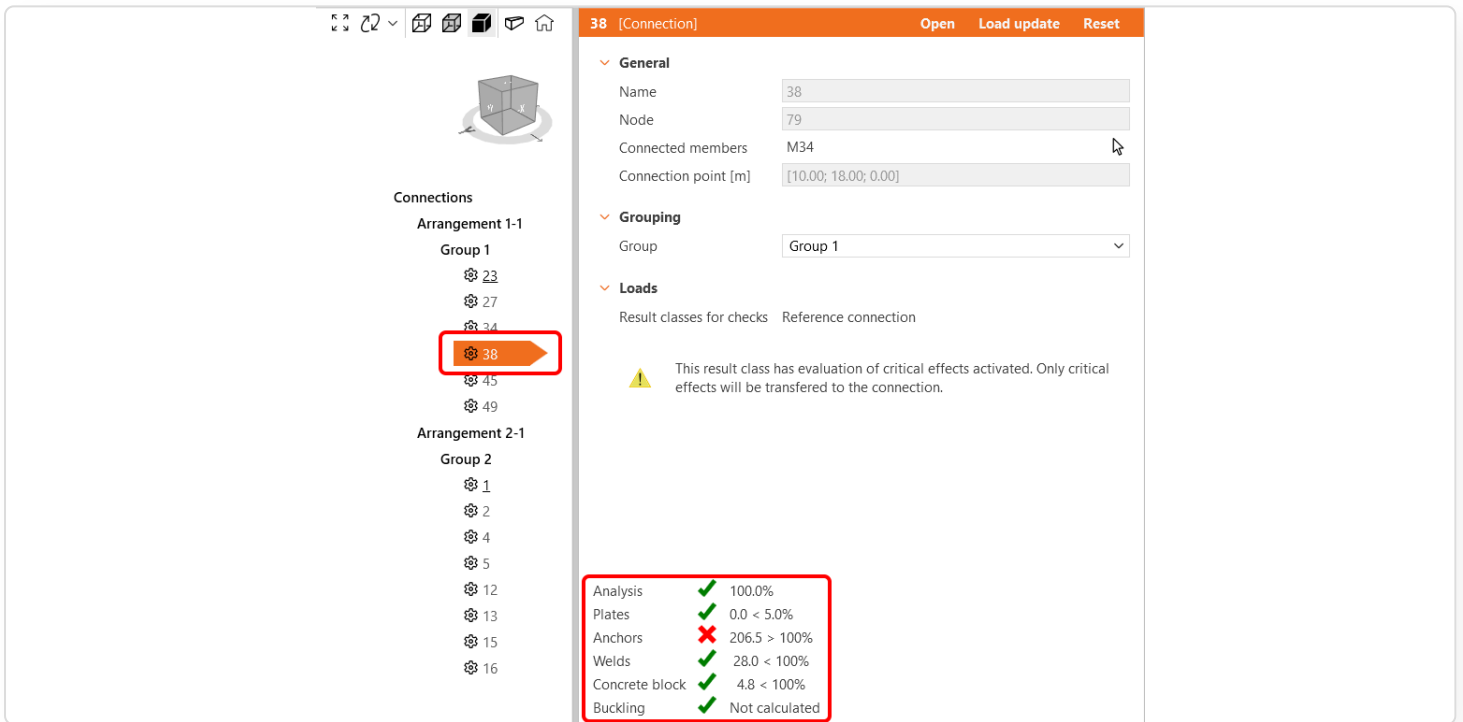



























Calculate the group of connections and browse the results for critical load effects. Optimize the design of the reference connection or even reshuffle groups to finish with the best result.



If the Calculate load extremes function is applied to a group of nodes where a member has more cross-section variants (e.g., a group of 10 nodes where a column has cross-section HEB300 in 6 nodes and HEB340 in 4 nodes), then more Load sub-groups are created to cover all the variants and stay on the safe side.

Calculate load extremes
 Critical connections 19
 Load sub-groups 3

	Load sub-group	Critical connection	Critical load effects	
>	[1]	N40	2	 
	[1]	N44	3	 
	[1]	N249	1	 
	[1]	N253	2	 
	[2]	N41	2	 
	[2]	N45	1	 
	[2]	N49	1	 
	[2]	N185	1	 
	[2]	N189	1	 
	[2]	N240	1	 
	[2]	N250	3	 
	[2]	N254	2	 
	[2]	N258	1	 
	[3]	N48	1	 
	[3]	N52	1	 

Limits for the Calculate load extremes function are currently not editable and are set to 0.1 for all internal forces.

▼ Load extremes limits

Normal force N [kN]

0.1

Shear force Vy [kN]

0.1

Shear force Vz [kN]

0.1

Torsion Mx [kNm]

0.1

Bending moment My [kNm]

0.1

Bending moment Mz [kNm]

0.1

Easy work with groups

A series of improvements is ready to boost your experience when working with multiple connections and groups in Checkbot.

Automatic group creation

When the first bulk import of multiple nodes from the FEA global structural model into Checkbot is performed, nodes are sorted into **Arrangements** based on their geometry, and the **Groups** are created automatically. For each **Group**, a **Reference** connection is set.

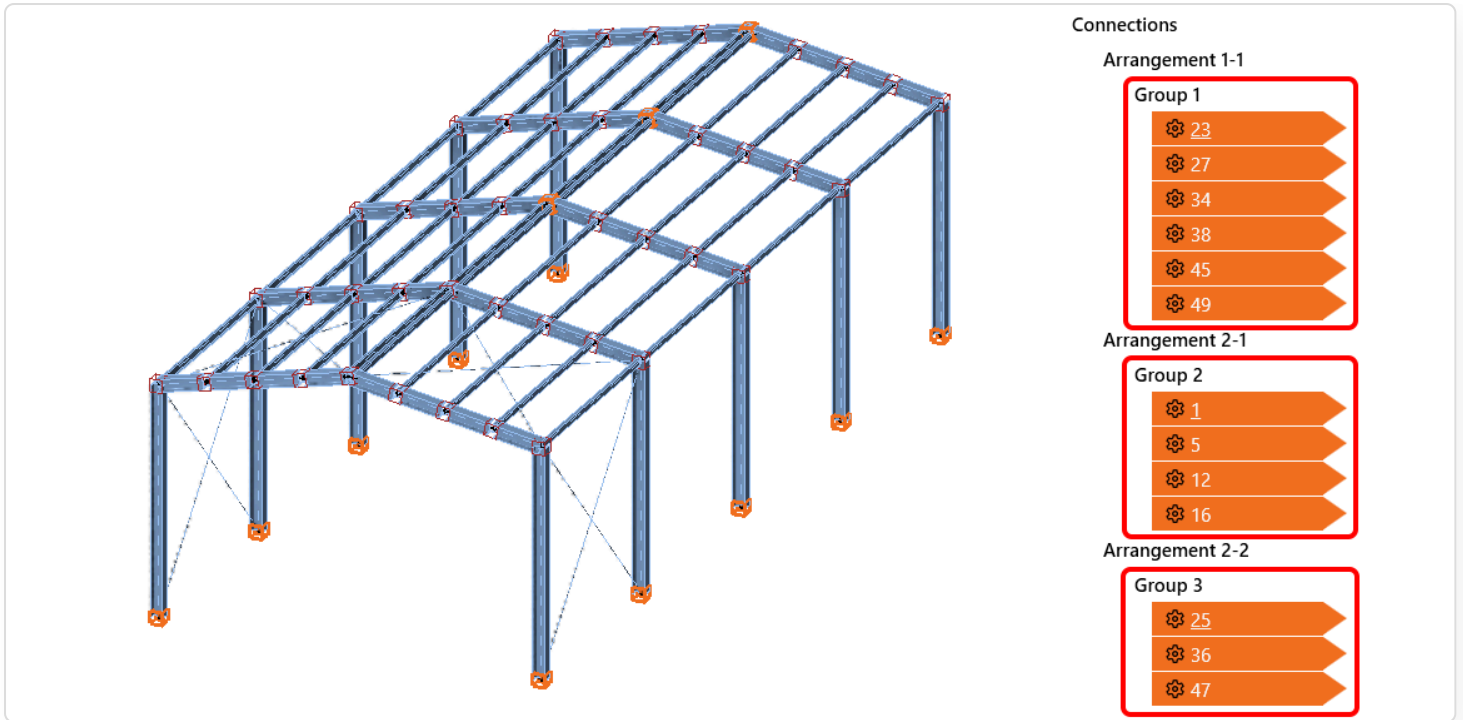

If there are any nodes imported later on, those are not inserted into any Group but are listed at the bottom of the appropriate Arrangement, ready to be manually sorted into existing or new Groups.

Connection group highlighted

When a Group of nodes is selected in the tree list, all nodes in the group are highlighted in the scene with a yellow contour line. When a node is selected, it is highlighted in the 3D scene with an orange color while the group highlight is still active.

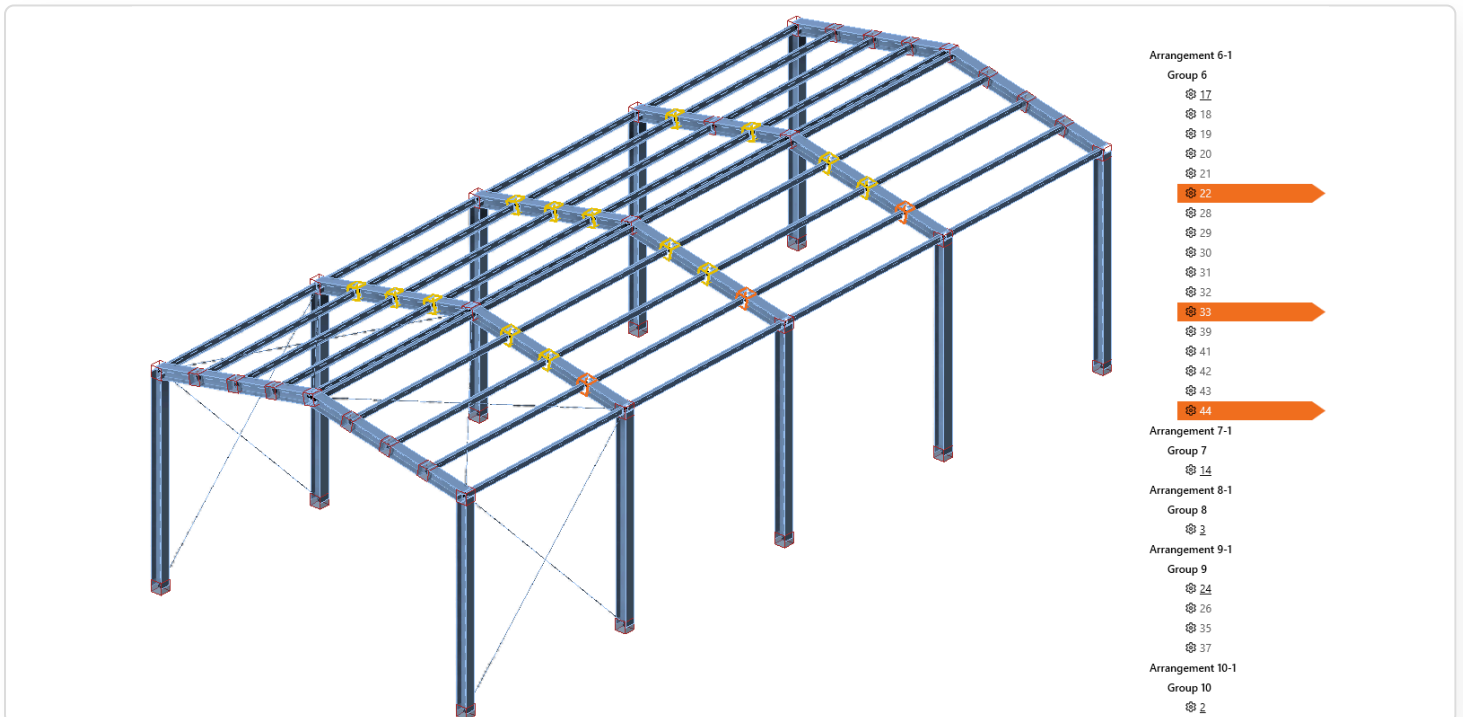

New tree and scene statuses

New statuses were added for easier navigation in the project so that nodes are distinguishable at a glance in both the tree list and the 3D scene. New statuses are:

- passing the code checks – a green box in the 3D scene and a green mark in the tree list
- failing the code checks – a red box in the 3D scene and a red cross in the tree list
- ready for calculation – a blue box in the 3D scene and a marked cog-wheel in the tree list

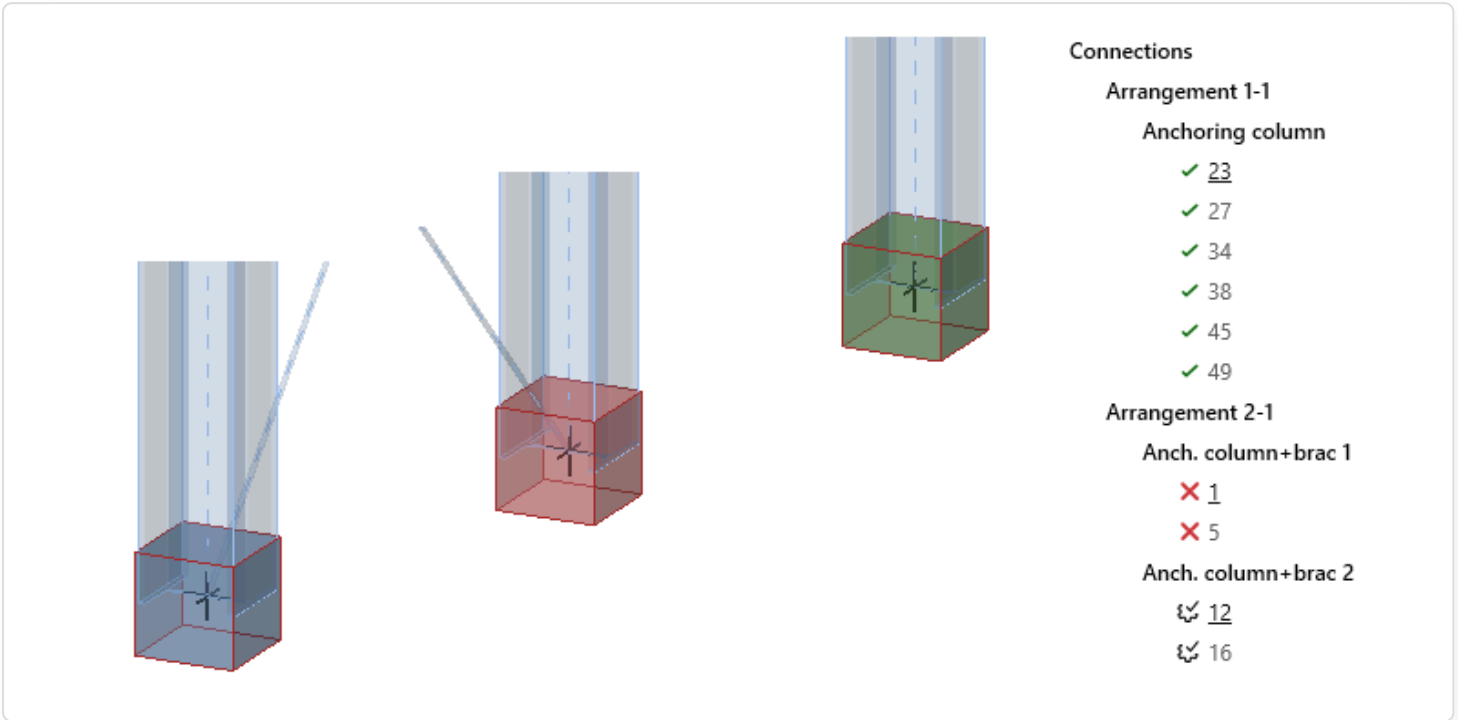

Smooth work with Checkbot and Connections

When a node is opened in Checkbot, a new window with the **lite version** of the Connection app is displayed. The Connection app can stay open, and it refreshes when you open other nodes from Checkbot, thus you save time from repeatedly opening and closing the Connection app.

When another node is opened, the previously displayed node in the Connection app is automatically saved and dismissed.

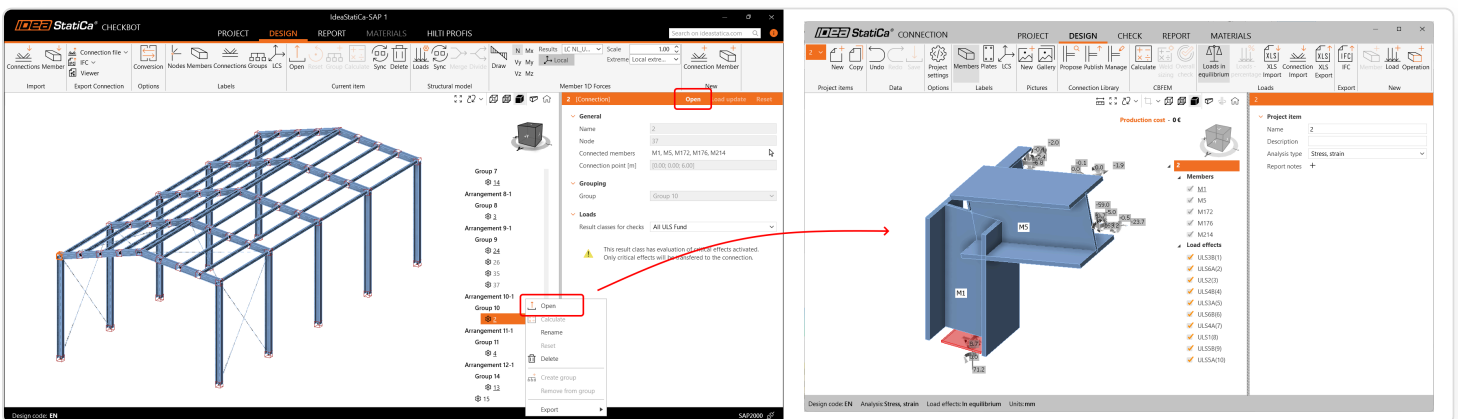

Consistent settings of Reference and Child connections

All settings applied to a Reference connection are automatically applied in bulk to all Child connections in the same group. This prevents time-consuming adjustments for nodes one by one. This includes:

- Project settings (gamma factors, detailing check, cost calculation, etc.)
- Member settings (Model Type and Forces in, including position and connected member face)
- Bearing member
- Load in equilibrium

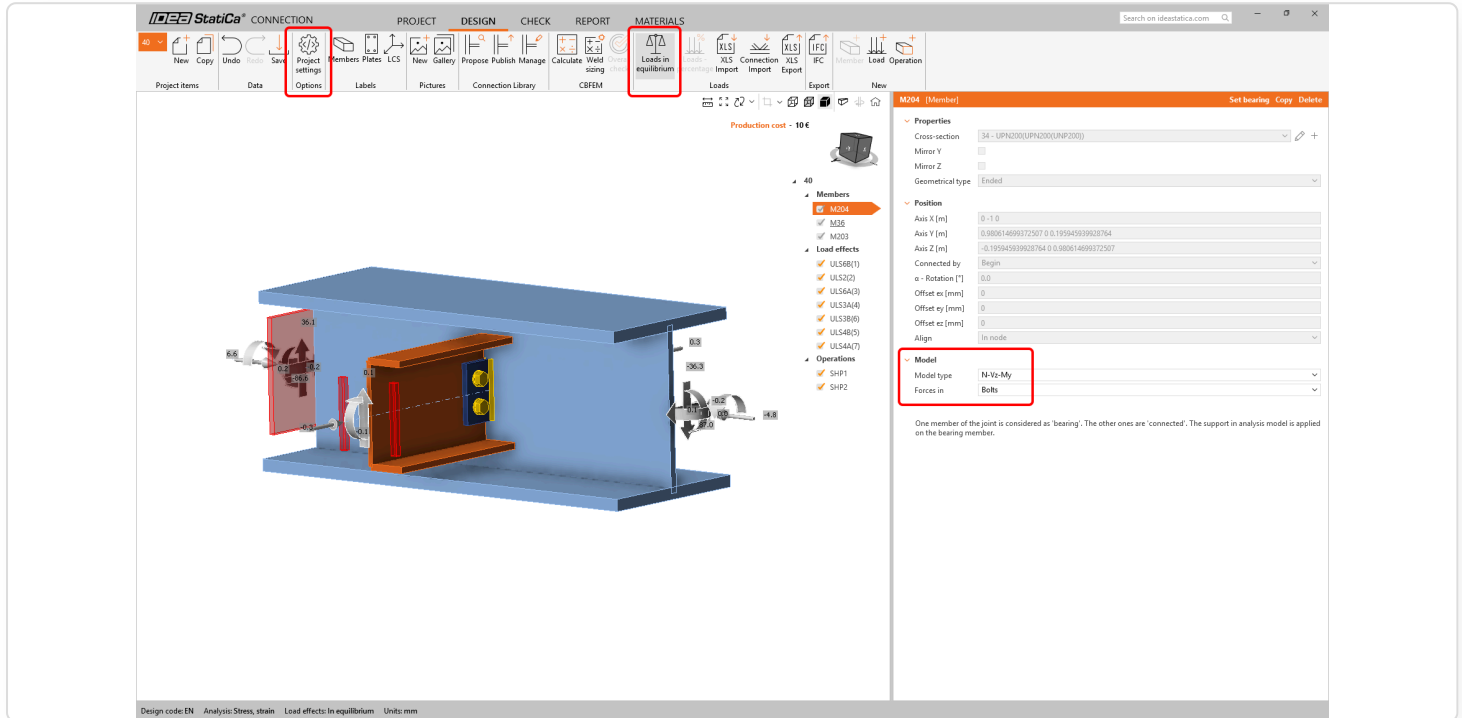

Calculation results stored in Checkbot

The results calculated for connections and members within a Checkbot project have been merged into one database persistently stored in the project folder. All apps interacting with the project share this one result database.

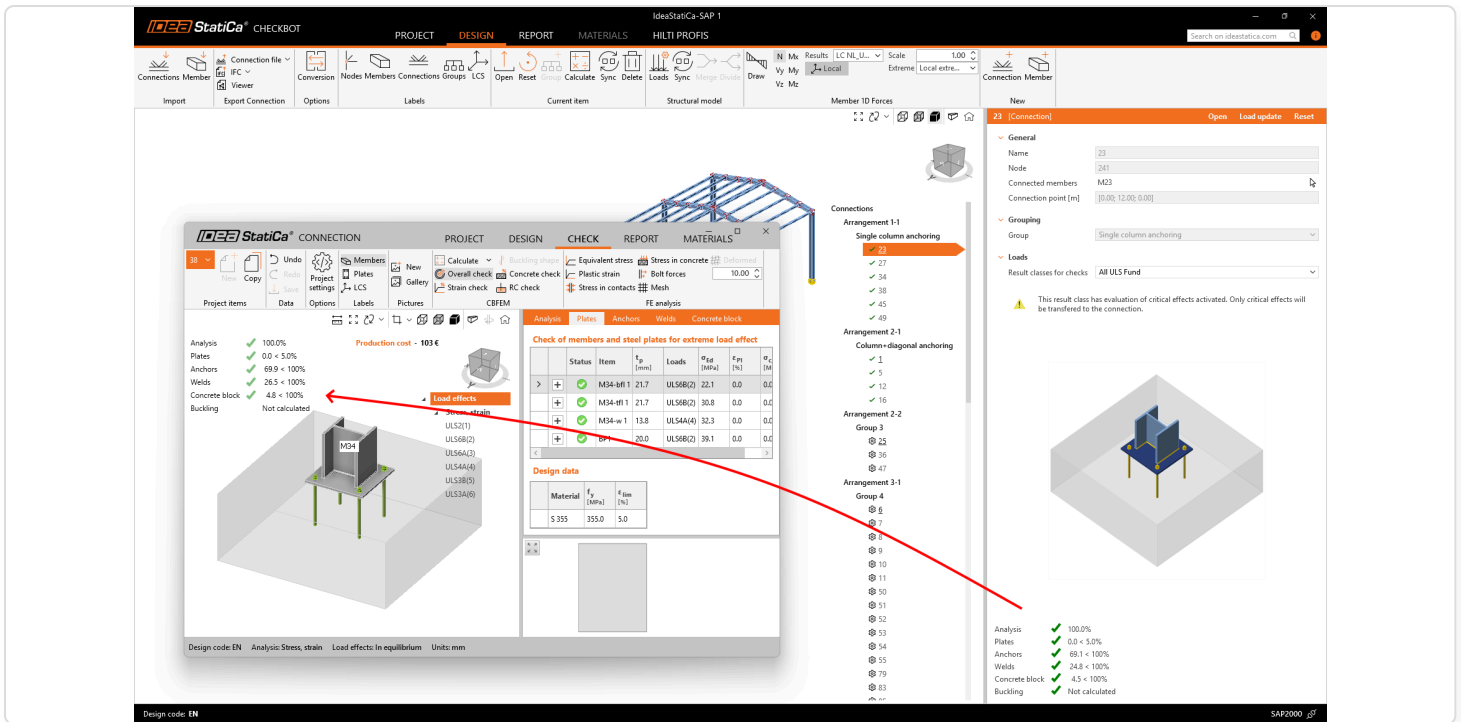

This prevents situations when the results and code checks from already completely calculated projects in Checkbot disappeared and had to be recalculated, or situations when results in Checkbot were missing when opening nodes in the Connection app. The same mechanism applies to members opened in the Member app.

BIM link between MIDAS CIVIL NX and IDEA StatiCa Checkbot

The BIM link between MIDAS CIVIL NX and IDEA StatiCa Checkbot allows you to import structural data, such as geometry, load cases, and load combinations, and reduce time and errors in designing steel connections. The direct live BIM link with MIDAS CIVIL NX enables users to transfer the materials, cross-sections, elements, and results of the global steel structural models to Checkbot. This data is used for the design and code-check of the steel connection in the IDEA StatiCa Connection app, eliminating laborious and error-prone manual input.

BIM link installation

MIDAS CIVIL NX is available in the [BIM Link Installer](#). Once installed, a desktop short-cut "IDEA StatiCa 25.0 for MIDAS Civil NX" to run the BIM link is created on your desktop.

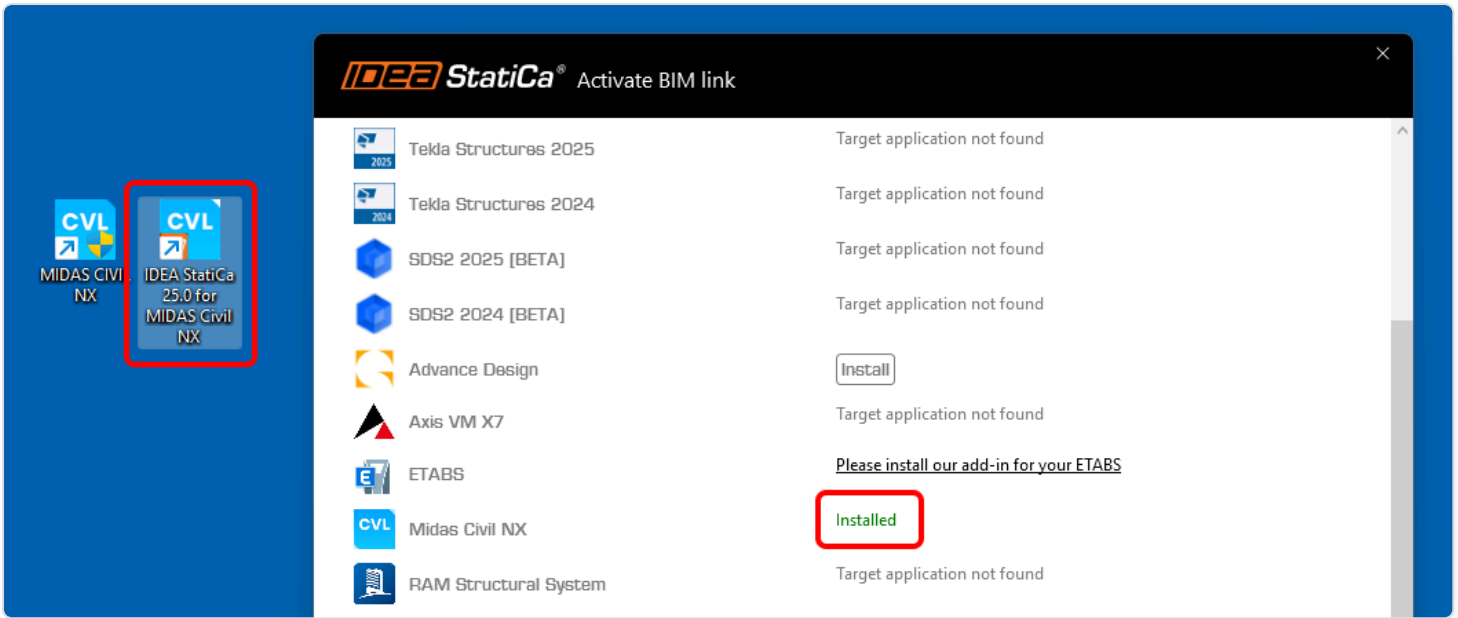

On the first launch of the "IDEA StatiCa 25.0 for MIDAS Civil NX" shortcut, you have to register the MIDAS MAPI-Key once and for all:

- Open your MIDAS CIVIL NX, go to the **Apps** tab, and open the **API Settings**. Here click **Refresh** to generate the MAPI-Key and enable **Connect API on Startup**.

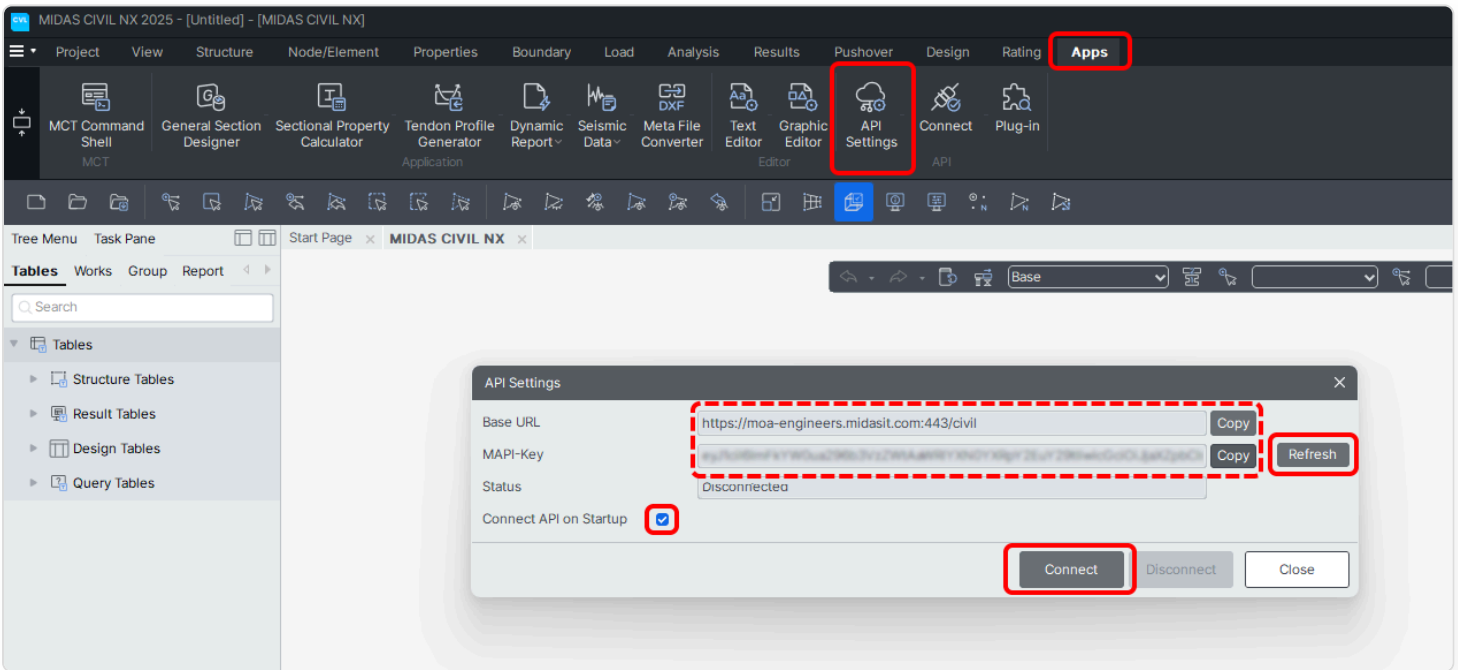

- Copy the **Base URL** and **MAPI-Key**, paste them into the **Idea to Midas Civil NX Integration Tool** and click **Validate**.

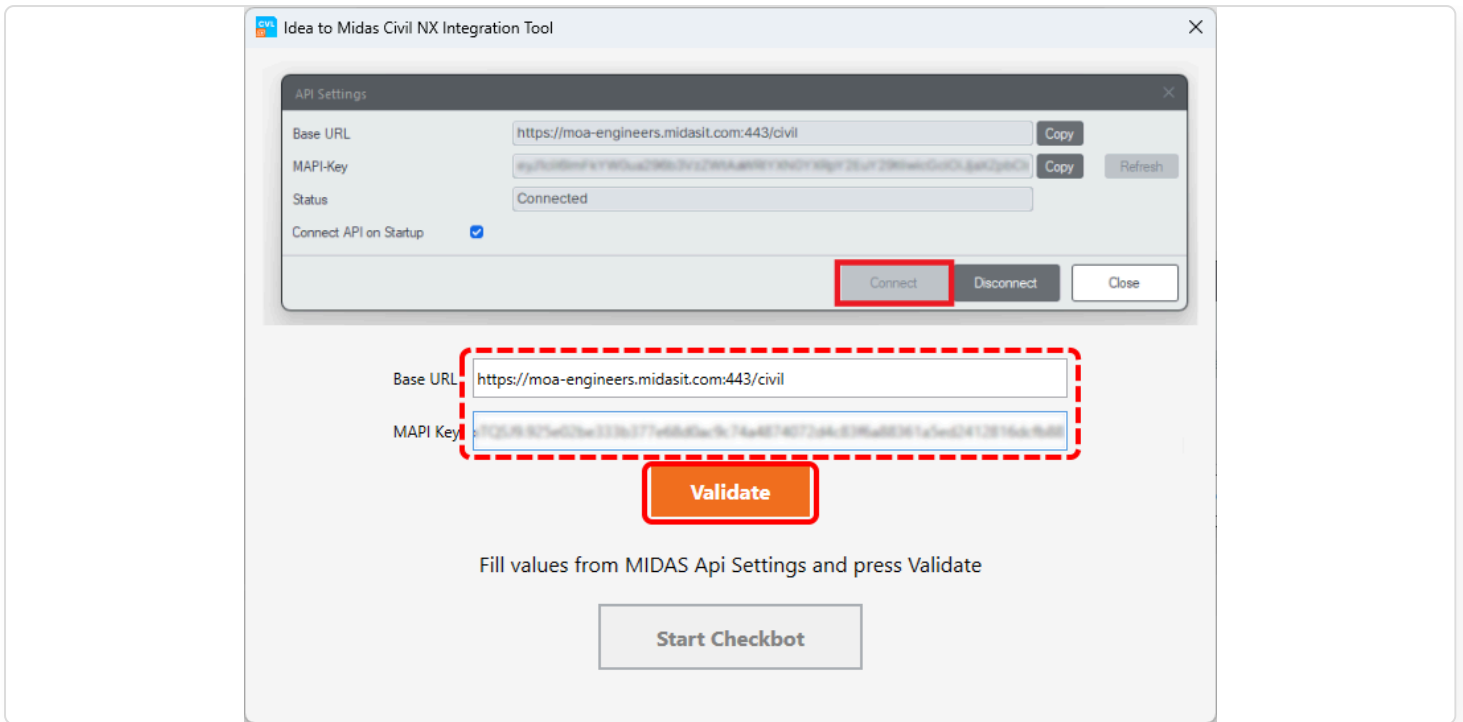

Once the MAPI-Key is validated, the data is stored in Windows Credentials unless the MAPI-Key is changed manually.

How to use the BIM link

Once installed and registered, use the same shortcut, "IDEA StatiCa 25.0 for MIDAS Civil NX", on your desktop. You will be asked to open the MIDAS project file and Checkbot will open simultaneously. You can then follow the standard [workflows in Checkbot](#).

Importing data from MIDAS CIVIL NX to IDEA StatiCa Checkbot

Elements: Members of any orientation and a wide variety of cross-sections can be imported. Tapered, composite, curved, and other special types are not supported and will be filtered out from the selection.

Eccentricities of members: Eccentricity is defined on the level of CSS in MIDAS. Eccentricity on a member CSS is supported in all the directions, but only in their absolute values (distance from the center of the CSS). Extreme Fiber eccentricities are not supported.

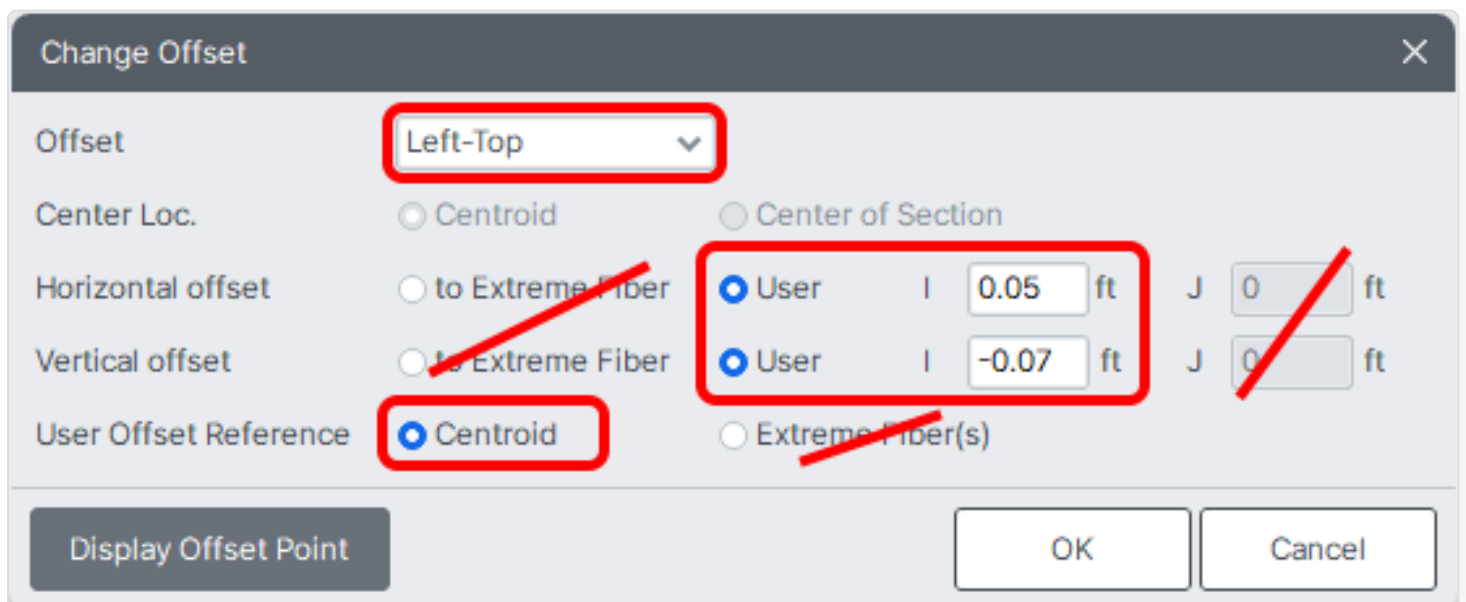

Note: Because of the coordinate system orientation used, the eccentricity value sign can be inverted when imported from MIDAS to Checkbot, but the real position, as shown in the 3D model, is correct.

Load effects: An unlimited number of static load cases ([manual](#), [API](#)) and general load combinations ([manual](#), [API](#)) is supported, other types are filtered out.

New REST API between Grasshopper and Connection

The Grasshopper plugin is updated to the new IDEA StatiCa Connection API and IOM version. It provides a new experience that is more in line with modern APIs. Each component is tightly coupled to the API interaction.

With the release of the new Rest Connection API, the current Grasshopper components related to the Old API (*ConHiddenCalculator*) will no longer work as this API is no longer supported from IDEA StatiCa version 24.1.3.

Installation of the plugin

Just as with older versions, the plugin can be [installed](#) through the [Rhino Package Manager](#). Open the Package Manager by typing **PackageManager** in the Rhino command prompt. Simply update or install the latest available version of the IDEA StatiCa plugin.

The new Grasshopper plugin's advantages

With the new version of the plugin, users have access to enhanced features of the new API and much easier interaction between Grasshopper and IDEA StatiCa Connection.

Old plugin version 0.1.X

- Hard to understand what is happening in the API when using components
- Lots of IO operations
- Long operations (like calculation) cause the script to freeze
- Lots of components for all objects
- Not working with multiple connections in a project
- Hard to choose a specific version of IDEA StatiCa

New plugin version 0.2.0

- Very tightly coupled to the actual API culture (easier transition to Python or C#)
- Projects are on the server until saved by the user
- API components are async, users can continue scripting while components are calculating
- Automatic decomposing of API objects
- Works natively with all connections in the project
- API attacher/runner allows an easy version specification
- Export IFC files directly in Grasshopper
- Template application workflow is unified with the application
- Pins and anchors are available to be defined in the IOM Components

Components overview

The new plugin is broken into two panels in the Grasshopper ribbon.

- 1 **App Common:** API components that are common across all IDEA StatiCa design APIs.
- 2 **Connection:** Components that are specific to the connection API.

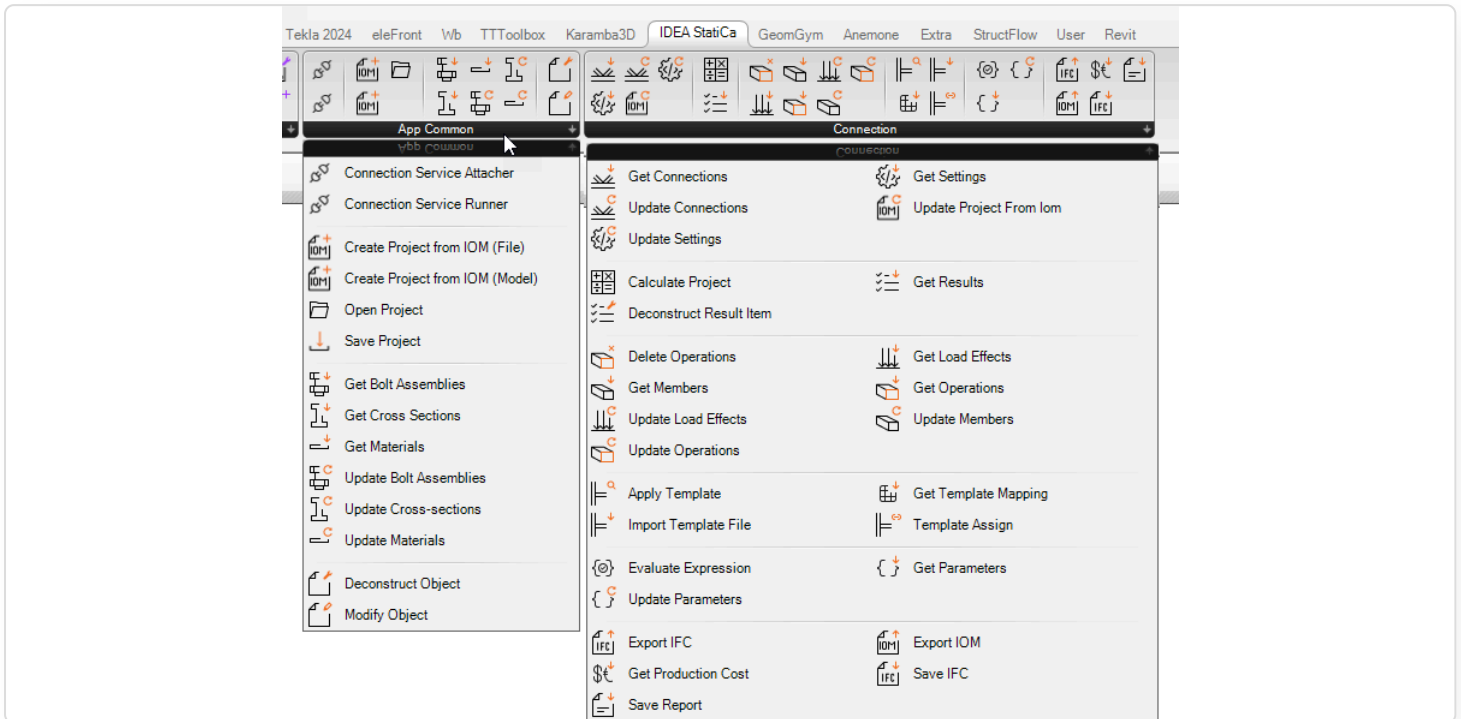

Connecting to the API through Grasshopper

Similar to other API clients, you can connect the Grasshopper script to a runner API instance (Connection Service Attacher) or start the service within Grasshopper (Connection Service Runner). A user must select one of the above components and run it before any of the API components can run.

Wrong:

You will be provided with an error message on the component if the component has tried to run without a valid API connection.

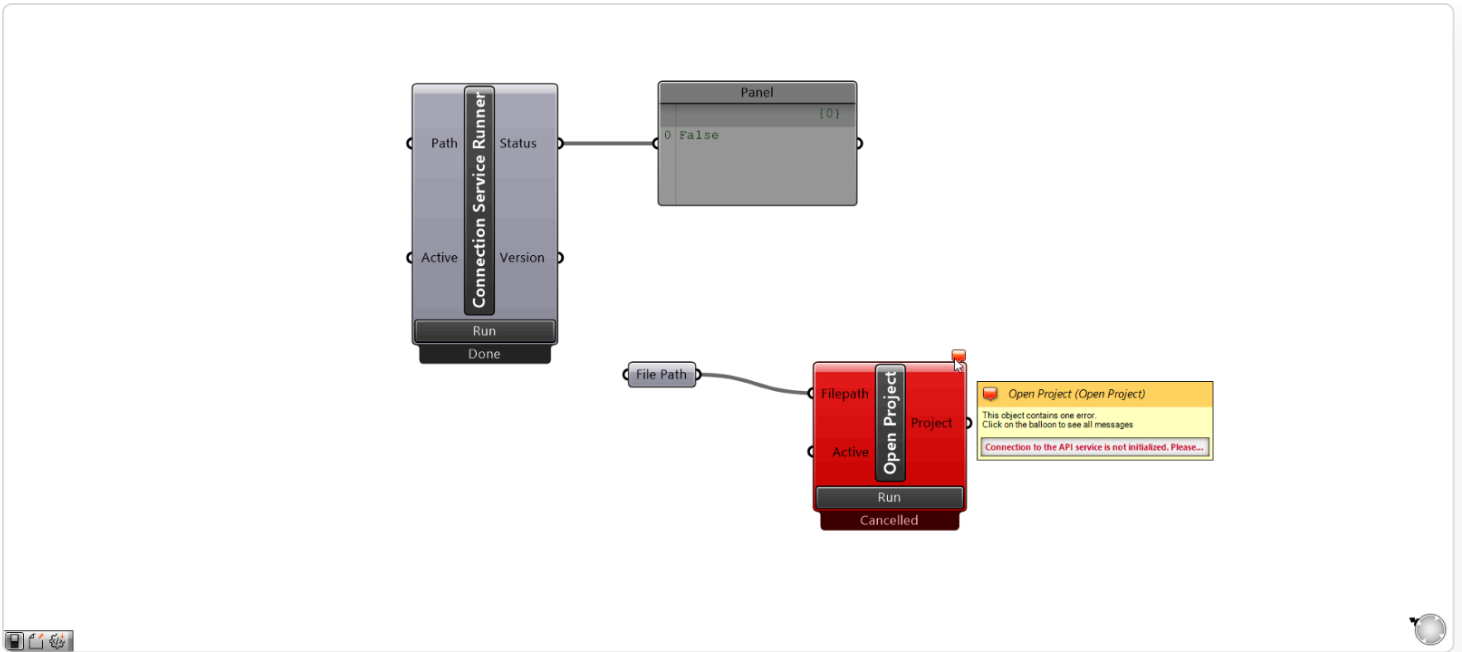

Correct:

Once there is a valid API connection, the Service component should not need to be re-run until the script is closed or navigated away from it. The connection is stored locally so that all components can access it.

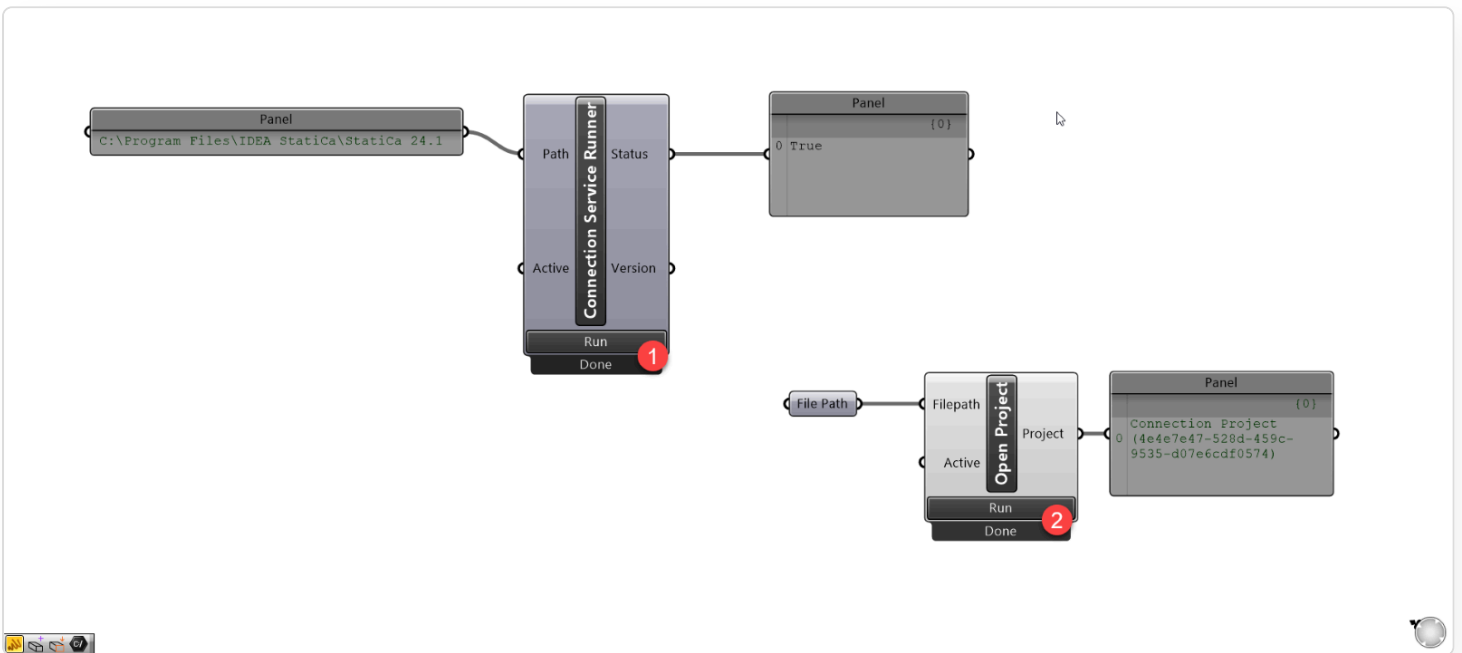

API components

The "Active" button below easily identifies components that interact with the API. A component can be run once by clicking the **Run** button or continually executed by using a true/false toggle wired into the active component.

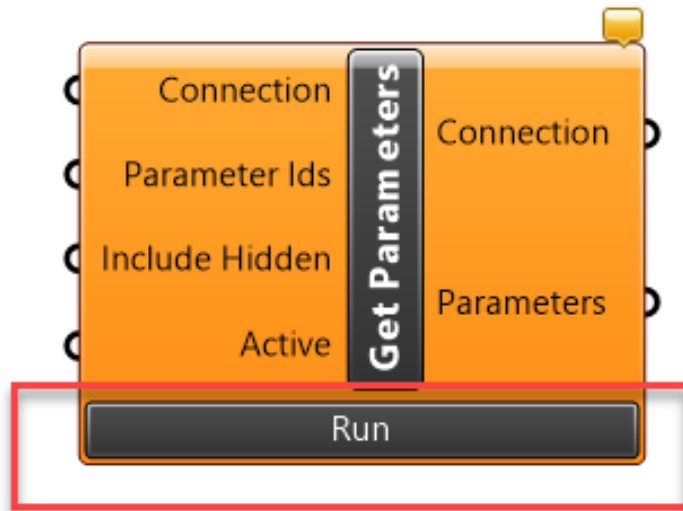

API components are closely related to Controllers in the Connection API. Controllers are either action-based (Calculation, Export, Report) or object-based (Load effect, Member, Parameters, etc.).

Action-based: Action-based controllers do specific tasks or operations on a specific connection or project, these include calculation or exporting functionality

Object-based: Object-based controllers will typically have a Get component and an Update component:

- **Get:** Retrieves all the controller-type objects in the Connection and retrieves specific objects that can be deconstructed or modified.
- **Update:** Updates provided objects that have been updated in the Grasshopper script. Objects are updated using the automatic Modify Object component.

Most API components will take inputs and provide outputs of objects, which can be deconstructed or modified. Providing components in this format reduces the overall number of components that users need to add.

The most basic example is deconstructing a Project to get the available information within it, such as the connections available.

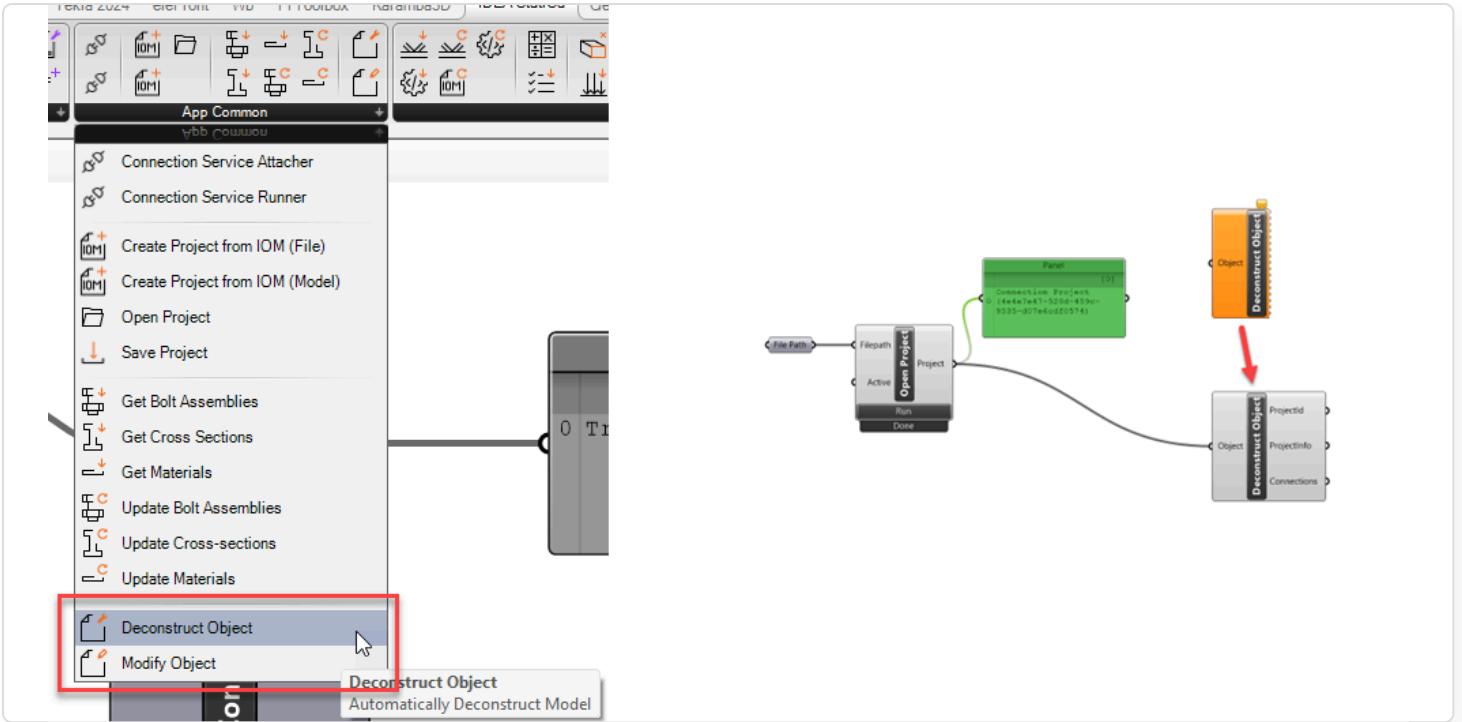

Simple example – updating connection parameters

See the simple example of how the Modify component works. The image below shows an example of using API and Automatic Object components in a simple application of a template and updating connection parameters.

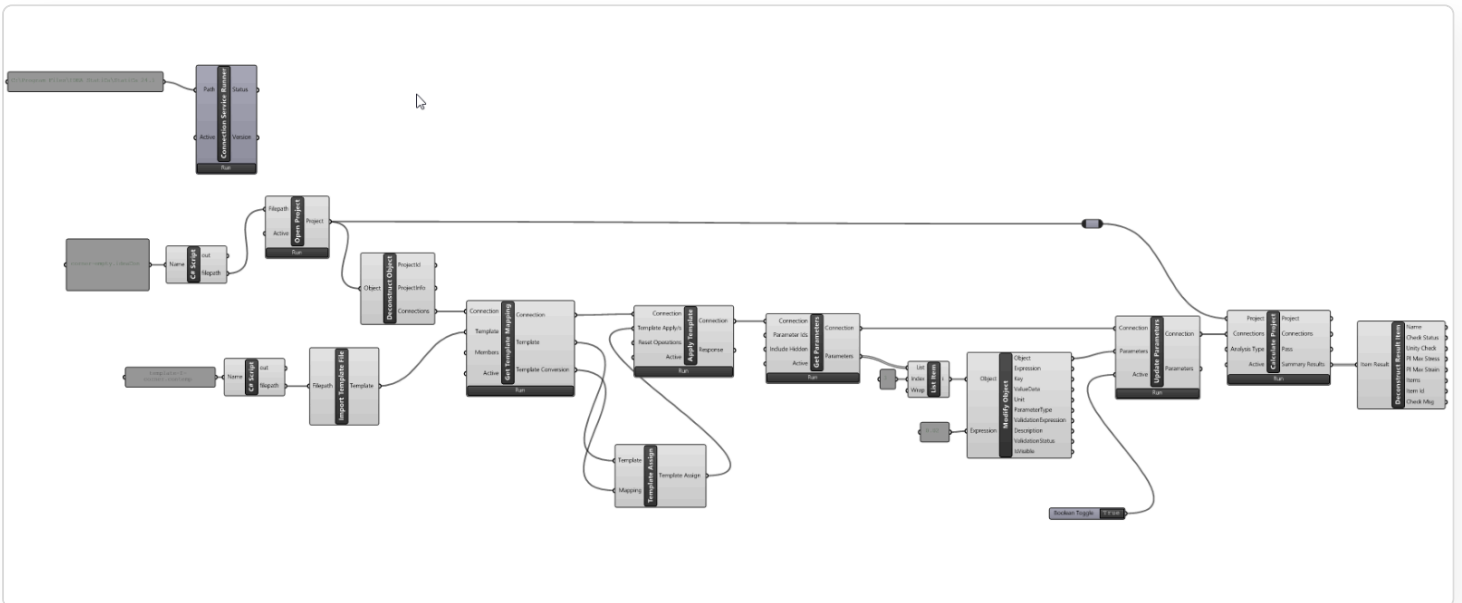

Examples ready to use

A full list of examples is available to users that download the plugin in the zipped file:

%appdata%\McNeel\Rhinoceros\packages\8.0\IdeaStatiCaGrasshopper\[0.0.0]\Examples 0.2.0.zip

- CON_Add Bolt assemblies
- CON_Add Materials
- CON_Apply Template
- CON_Create Project from IOM File
- CON_Create Project from IOM Model
- CON_Evaluate Expression
- CON_Export IFC
- CON_Export IOM
- CON_Get and update Load effects
- CON_Get and update members
- CON_Get and update operations
- CON_Get Connection Cost
- CON_Get Cross-sections
- CON_Open, Calculate and Get results
- CON_Save Report
- CON_Update Project From IOM
- IOM_Convert SAF to IOM and add Connection Components
- IOM_Create general plated cross-section
- IOM_Create IDEA connection using IOM_duplicate
- IOM_Create IOM connection with IOM Model and Results
- IOM_Create Open Model Result
- IOM_Create Pin Example LinkedIn
- IOM_Create Pins and Anchor Examples
- IOM_Create space frame node connection
- MPRI_Search and Query Databases
- PROG_Create custom css using csharp node

Version compatibility

The new plugin, version 0.2.0, is available in the [Rhino Package Manager](#) and will work with IDEA StatiCa version 24.1.3 and newer.

The older version 0.1.x will also be available and will work with IDEA StatiCa version 24.1.2 and older.

Released in IDEA StatiCa version 24.1.4

Import of anchors from Tekla Structures

Thanks to the BIM link between Tekla Structures and IDEA StatiCa, you can import anchoring data from your CAD model into the Checkbot app and code-check it in the Connection app.

Import complete anchoring from Tekla Structures to IDEA StatiCa

Next to importing structural details (members, plates, bolts, welds) created in your Tekla Structures CAD project, you can also import the designed anchoring parts, such as anchors, base plates, and concrete blocks.

Supported data for anchoring parts import:

- base plate dimensions, material properties
- anchor layout
- anchor profile, anchor grade (material), and anchor assembly properties
- foundation concrete block, concrete material properties

The BIM link works best in Tekla Structures 2025 and with out-of-the-box created macros/components that have been updated to contain all data readable by IDEA StatiCa Checkbot.

Earlier versions (Tekla Structures 2024 and older) are [also supported](#), however, some missing data in macros may not be imported correctly.

Known limitations

- The grout and gap between the base plate and concrete face are not supported
- The concrete block dimensions (offset) might not be transferred precisely
- Only straight anchors are supported

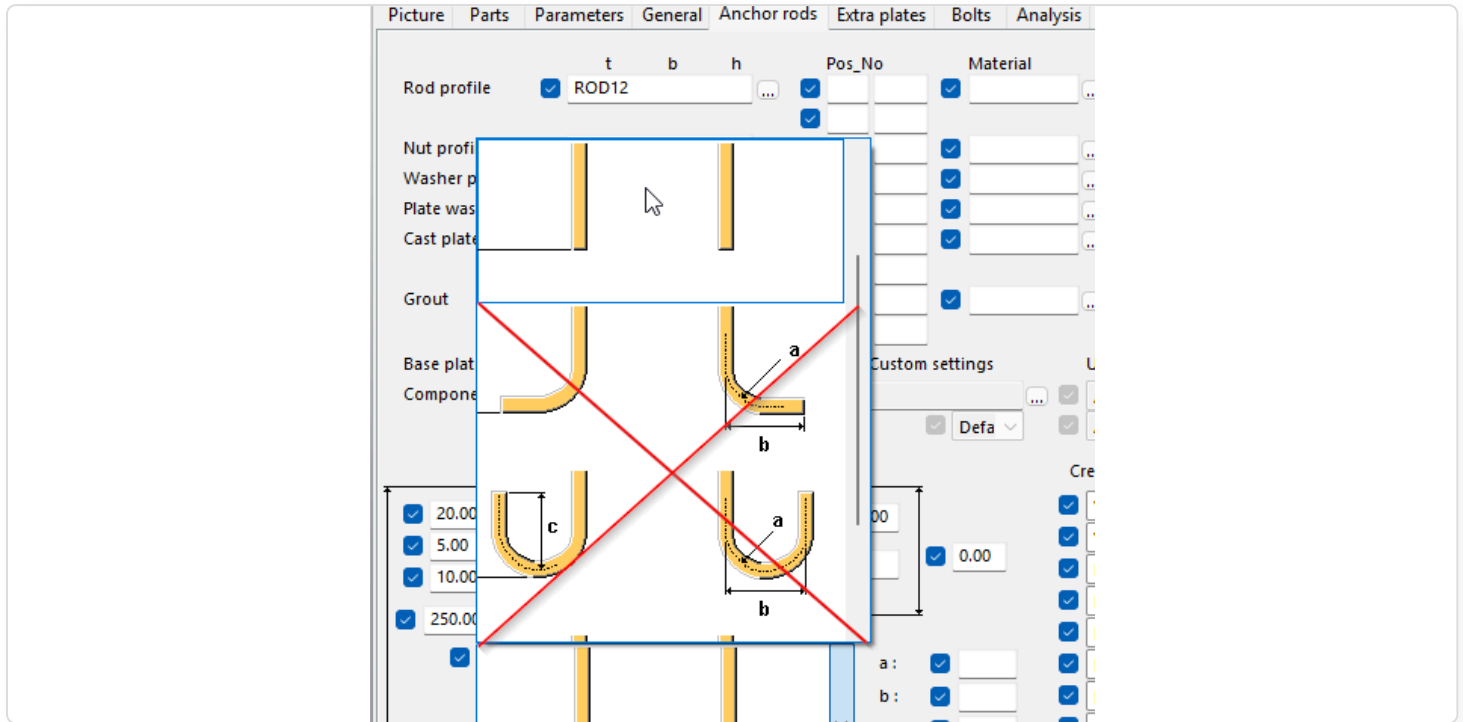

More about the design of anchoring in IDEA StatiCa is [in this article](#).

RCS API for streamlined, simplified, and efficient design processes

The modern IDEA StatiCa RCS API solution is comprehensive, programming-language independent, web-based, and meets the advanced needs of professionals seeking simplified and efficient design processes for reinforced concrete structures.

The RCS API facilitates integration into any project framework with minimal prerequisites. The API is based on REST technology, and it supports clients for both .Net (C#) and Python, with the flexibility to extend support to additional programming languages.

The screenshot shows the IDEA StatiCa developer website. The main content area is titled "Open an RCS project" and "Open existing project". It includes code snippets for opening an existing project and creating a new project from an IOM file. A note states: "There is not currently a way to create projects from scratch without first defining an IOM Model." The left sidebar contains a navigation menu with categories like "IDEA StatiCa API", "Examples", "API Reference", and "References".

Open an RCS project
Once the connection with RCS is established we need to first open or create an RCS project (ideaRcs).

Open existing project
In most cases will want to open an existing project that is available on our computer.

```
.Net Python
//Getting the directory path to the sample file in example project.
string samplePath = Directory.GetParent(Directory.GetCurrentDirectory()).Parent.Parent.FullName;

//filepath to existing _ideaRcs project
string rcsFilePath = Path.Combine(samplePath, "SampleFiles\\Reinforced concrete T-section.IdeaRcs");

//Opens project on the server side to start performing operations
bool okay = await client.OpenProjectAsync(rcsFilePath, CancellationToken.None);
```

Create project from IOM
We can also **Create** a new RCS Project. To create a new RCS project file, we will need to define the RCS Model using IDEA Open Model(IOM). See [here](#) for examples of creating IDEA Open Model for RCS can be found.

NOTE
There is not currently a way to create projects from scratch without first defining an IOM Model.

When creating a project from IOM, we can choose to create directly from a `OpenModel` class in memory:

```
.Net Python
//OpenModel defined in Memory
OpenModel model = new OpenModel();

await client.CreateProjectFromIOMAsync(model, CancellationToken.None);
```

Documentation, including installation instructions and example use-cases, is readily available on the **developer website**, providing comprehensive guidance for users to get started with the RCS API quickly:

[Getting Started RCS API](#)

[RCS automation API - all documentation](#)

The RCS API allows the loading of an RCS project by:

- Import from a created IOM file, or
- Opening an existing RCS file

Once an RCS project is active, you can:

- Get information about the project, including **project data**, **available sections**, and **design members**.
- Update code settings.
- Update the Reinforced **cross-section reinforcement**, **tendons**, or the entire cross-section using a template file (.nav).
- Run the calculation for all or selected sections.
- Retrieve results for all or selected sections.

The API marks our commitment to providing a scalable, user-friendly tool for the optimization and automation of concrete structural reinforced cross-section designs. This streamlines the design workflow and opens future advancements, including the consideration of web-based calculation services and integration with platforms like VIKTOR apps or Rhino Compute.

Released in IDEA StatiCa patch 23.1.3.

RCS API updated to REST API

The RCS API is built on REST Open API architecture and runs over an HTTP protocol. The current version of the API creates a REST server that is hosted locally on a user's computer.

The .Net RcsApiClient is compatible with projects using .NET 6.0 or greater. The .NET client is set up to work asynchronously. The methods of the API have been enriched and updated.

Note: Some parts of the original code have been changed, so older projects must be updated as they might not work properly with the latest IDEA StatiCa version.

```
def get_section_details(rcs_project_filename):
    ideaSetupDir = idea_statica_setup.get_ideasetup_path(ideaStatiCa_Versio

    #print("IDEA StatiCa found : ", ideaSetupDir)

    freeTcp = idea_statica_setup.get_free_port()
    #print("Free tcp port on localhost :", freeTcp)

    try:
        rcsClient = rcs_client.RcsClient(ideaSetupDir, freeTcp)

        print(rcsClient.getServiceDetails())

        projectId = rcsClient.OpenProject(rcs_project_filename)

        #brief_result_tools.print_sections_in_project(rcsClient.Project)

        #brief_result_tools.print_reinfcss_in_project(rcsClient.Project)

        #sections_in_project = rcsClient.Project.Sections

        ids = []
        names = []

# Defining the host is optional and defaults to http://localhost
# See configuration.py for a list of all supported configuration parameters.
configuration = ideastatica_rcs_api.Configuration(
    host = "http://localhost"
)

# Enter a context with an instance of the API client
with ideastatica_rcs_api.ApiClient(configuration) as api_client:

    # Create an instance of the API class
    api_instance = ideastatica_rcs_api.ProjectApi(api_client)
    rcs_file = None # bytearray | (optional)

    try:
        # Open Rcs project from rcsFile
        api_response = api_instance.open_project(rcs_file=rcs_file)
        print("The response of ProjectApi->open_project:\n")
        pprint(api_response)
    except Exception as e:
        print("Exception when calling ProjectApi->open_project: %s\n" % e)
```

Released in IDEA StatiCa version 25.0.

Supported BIM links in version 25.0

We have taken several actions to ensure the consistent update process of our BIM links.

The latest two major releases supported

In each major release of IDEA StatiCa (this year, it will be 25.0 and 25.1), we support the two most recent major releases of each linked application. The older versions become obsolete, this happens in major IDEA StatiCa releases only (patches will never disconnect older versions). On the other hand, when a new major release of the BIM application comes, we develop/update the link in two months – the link appears in a patch of IDEA StatiCa.

The current state of the supported versions is always presented on our website. With the 25.0 release, we will support the versions presented in the first column of the table. The “In development” column represents the newest versions that will start to be supported in a patch of 25.0. The third column shows versions that are no longer supported.

IDEA StatiCa - Steel		25.0		
Application	Supported	In development	Obsolete	
Advance Design	2024, 2025	-	-	
Advance Steel	2024, 2025	-	-	
AxisVM	X7.2, X7.3	X8.1	-	
ETABS	21, 22	-	-	
midas Civil / Gen	2024, 2025	-	2023	
midas Civil NX	2024, 2025	-	-	
RAM Structural System	23, 24	-	-	
Revit	2024, 2025	-	-	
RFEM / RSTAB	5.37 / 8.37, 6.09 / 9.09, 6.10 / 9.10	-	5.35 / 8.35, 5.36 / 8.36, 6.06 / 9.06, 6.07 / 9.07, 6.08 / 9.08	
Robot Structural Analysis	2024, 2025	-	-	
SAP2000	25, 26	-	-	
SCIA Engineer	24, 25	-	22.1	
SDS2	2024, 2025	2025-01	2023i	
STAAD.Pro	2023, 2024	-	-	
Tekla Structures	2024, 2025	-	2023	
IDEA StatiCa - Concrete		25.0		
Application	Supported	In development	Obsolete	
Advance Design	2024, 2025	-	-	
AxisVM	X7.2, X7.3	X8.1	-	
midas Civil / Gen	2024, 2025	-	2023	
RFEM / RSTAB	5.37 / 8.37, 6.09 / 9.09, 6.10 / 9.10	-	5.35 / 8.35, 5.36 / 8.36, 6.06 / 9.06, 6.07 / 9.07, 6.08 / 9.08	
Robot Structural Analysis	2024, 2025	-	-	
SAP2000	25, 26	-	-	
SCIA Engineer	24, 25	-	22.1	

The currently supported versions in the latest IDEA StatiCa patch can be found in the [BIM links: Supported versions of 3rd party applications](#) page.

The older versions of BIM-linked applications may still be used. Nevertheless, we will not actively support the projects or fix possible bugs.

Usability and Licensing

New Launcher application

The Launcher application provides a simplified overview of the user's options, relevant news content and their progress in e-learning courses.

Replacement of the original start-up window brings both visual and functional upgrades.

All IDEA StatiCa tools are listed in the top ribbon simply categorized under Steel, Concrete, and BIM groups, with new application icons.

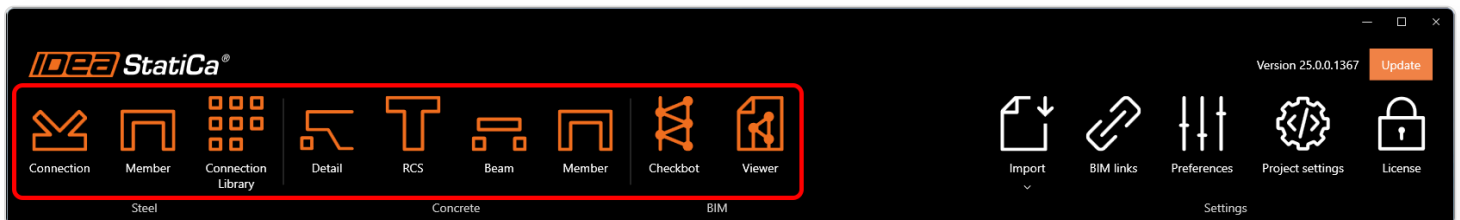

IDEA StatiCa software settings are placed in the right part of the main ribbon.

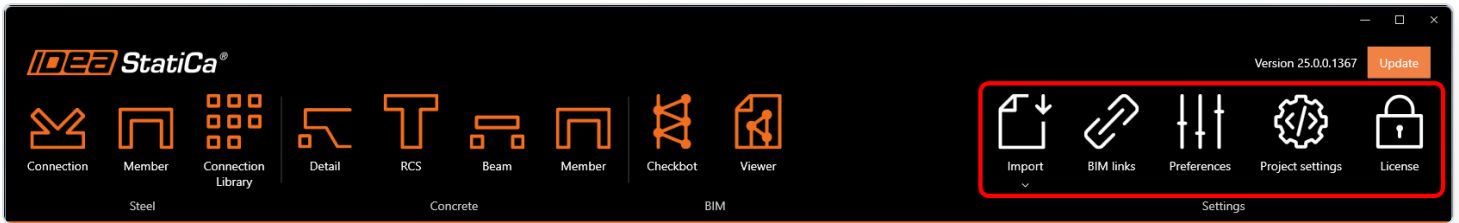

An information block in the top right corner provides the currently installed version number, together with a button for possible updates when a new version becomes available.

The main window space is divided into four areas:

- a list of recently opened projects
- news-feed from current online content
- direct links to support center with different categories
- an overview of progress in e-learning courses

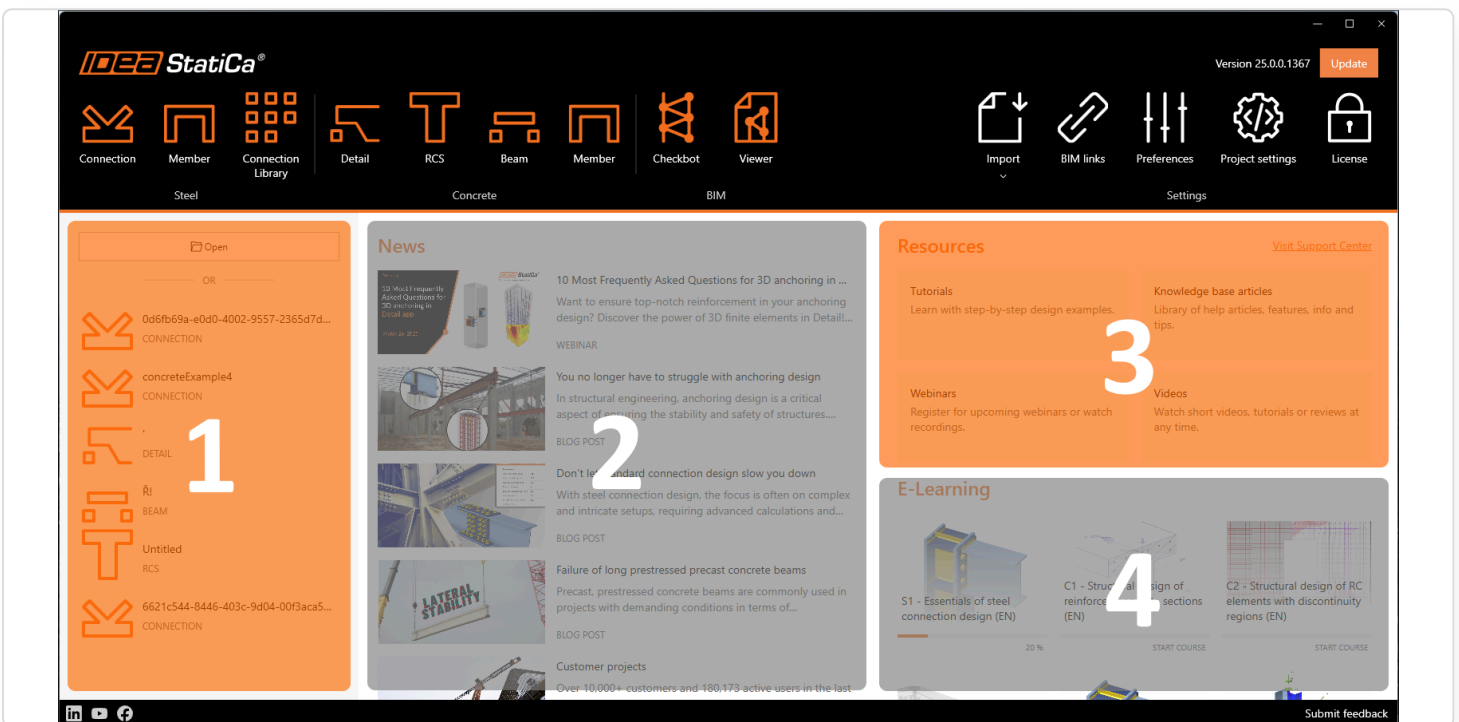

New style of applications in 25.0

A refreshed visual style has been applied across all IDEA StatiCa apps, offering a consistent interface, updated components, and improved navigation – aligned with the new Launcher and designed to support clarity in technical workflows.

A unified visual style has been rolled out across all core applications, including Connection, Detail, Checkbot, and Member. This update introduces consistent headers, footers, fonts, and tab designs, along with a refined ribbon and improved backstage view. The interface now features a full black strip with a refreshed logo, simplified controls, and a modernized search box, all aligned with the new Launcher design. This uniformity helps users move between applications more comfortably, without adjusting to differing layouts or styles.

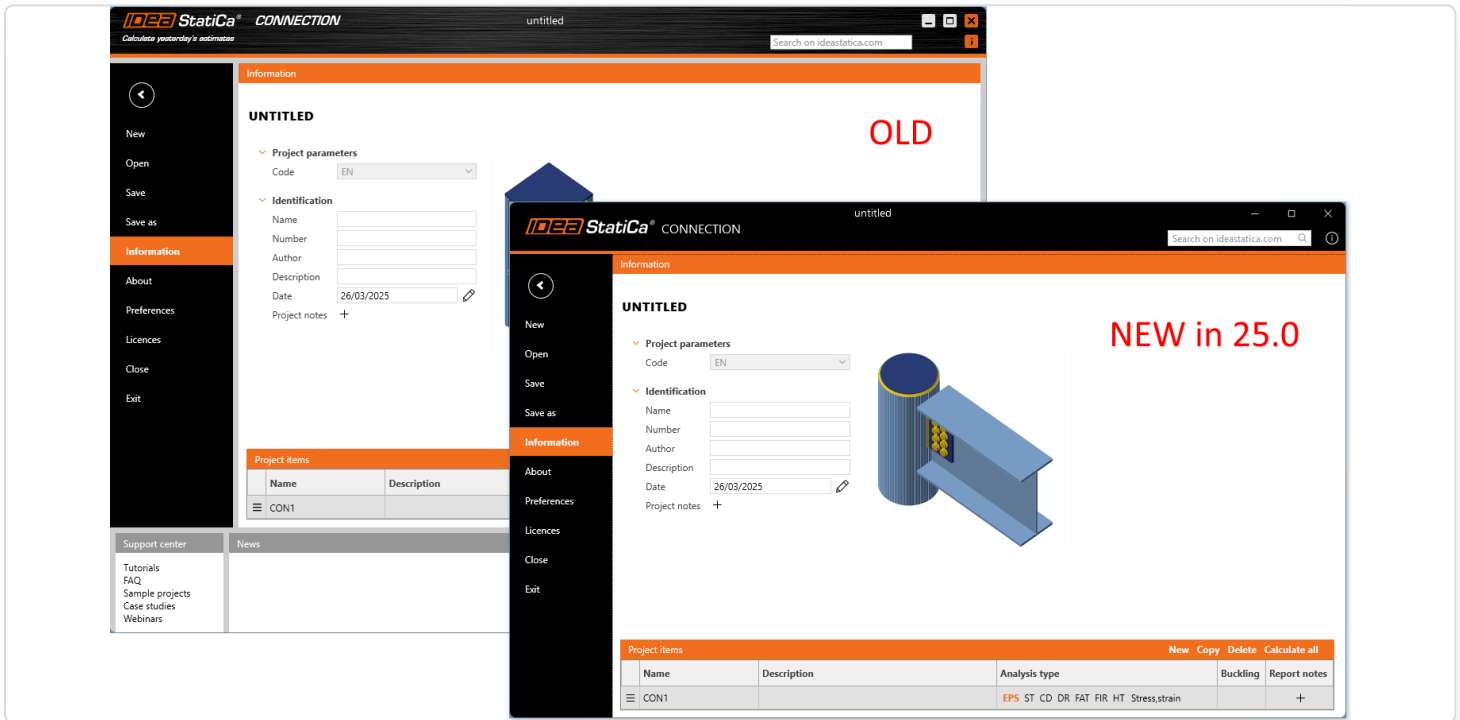
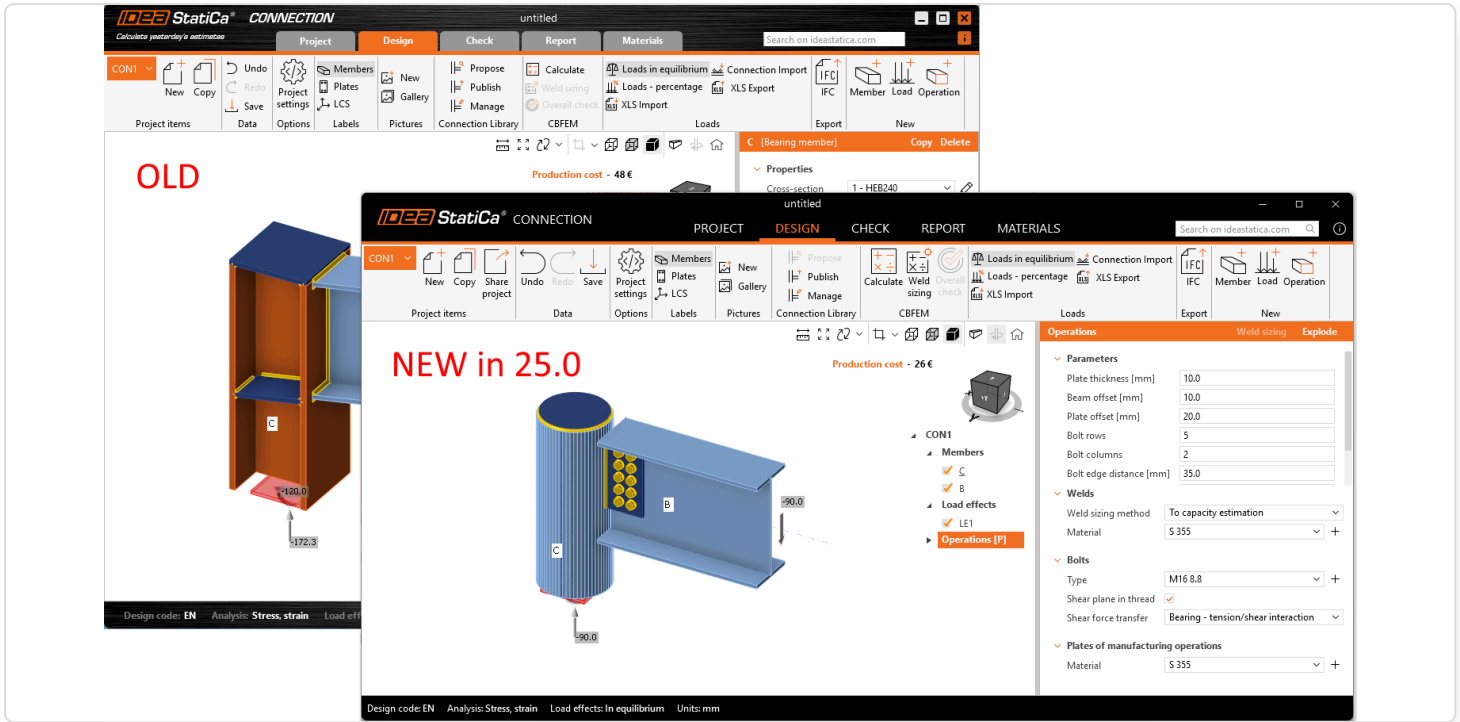

In support of the Checkbot-driven workflow, the Connection app has also received a tailored update. When launched from **Checkbot**, Connection now adopts a **gray color scheme** with a lighter header, following the Single Check app concept. This clarifies its role as a design tool within the broader checking process, helping users focus on modeling.

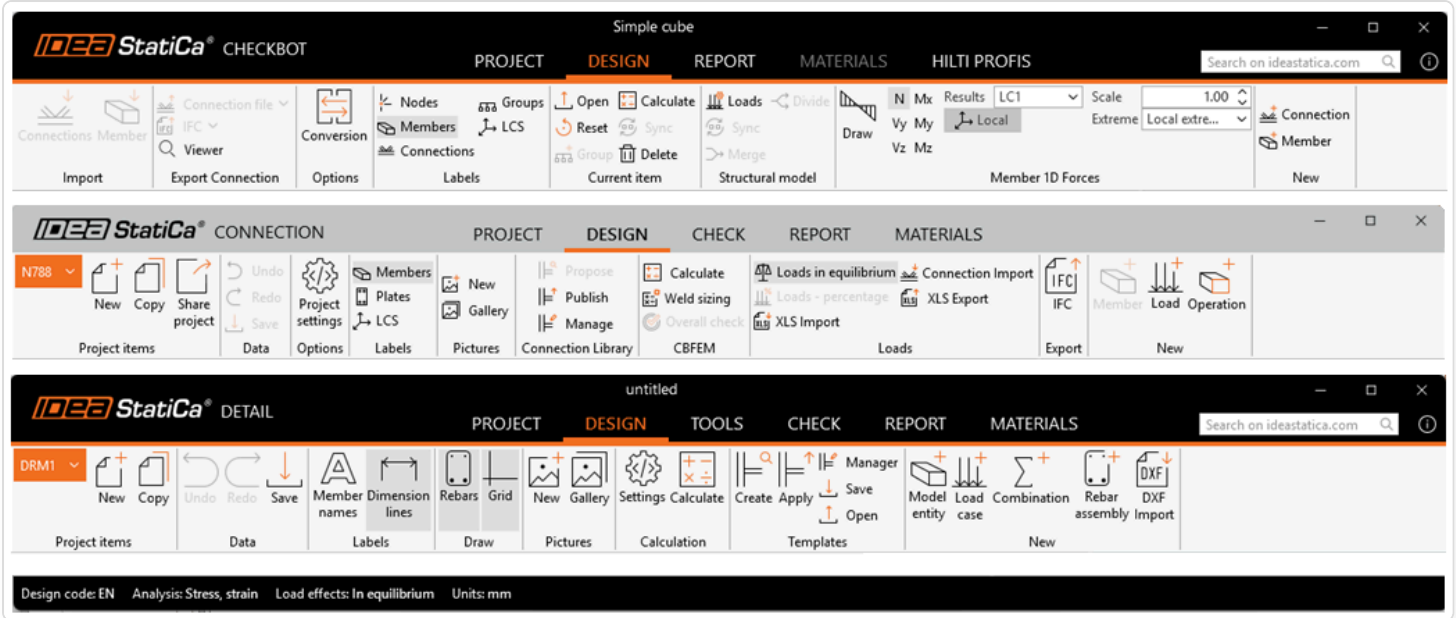

The UI of the IDEA StatiCa Viewer tool

IDEA StatiCa Viewer is a free cloud tool for sharing structural data among the designers involved in connection or anchoring design. It was tailor-made for visualizing the detailed connection arrangements in the 3D scene and sharing the model data among connection designers at different stages.

You can find even more comprehensive information about the possible workflows with the Viewer tool in [Project Viewer – useful and costless article](#).

How does it work?

A user can access the Viewer tool either through the URL viewer.ideastatica.com, directly from the Checkbot application, or from the Starting screen menu.



If the first option is used, the initial screen offers several options:

- **Drag and Drop** – for already existing model files
- **Browse** – for opening the project file from a hard drive
- **Sample project** – for opening a Demo project file with different types of connections

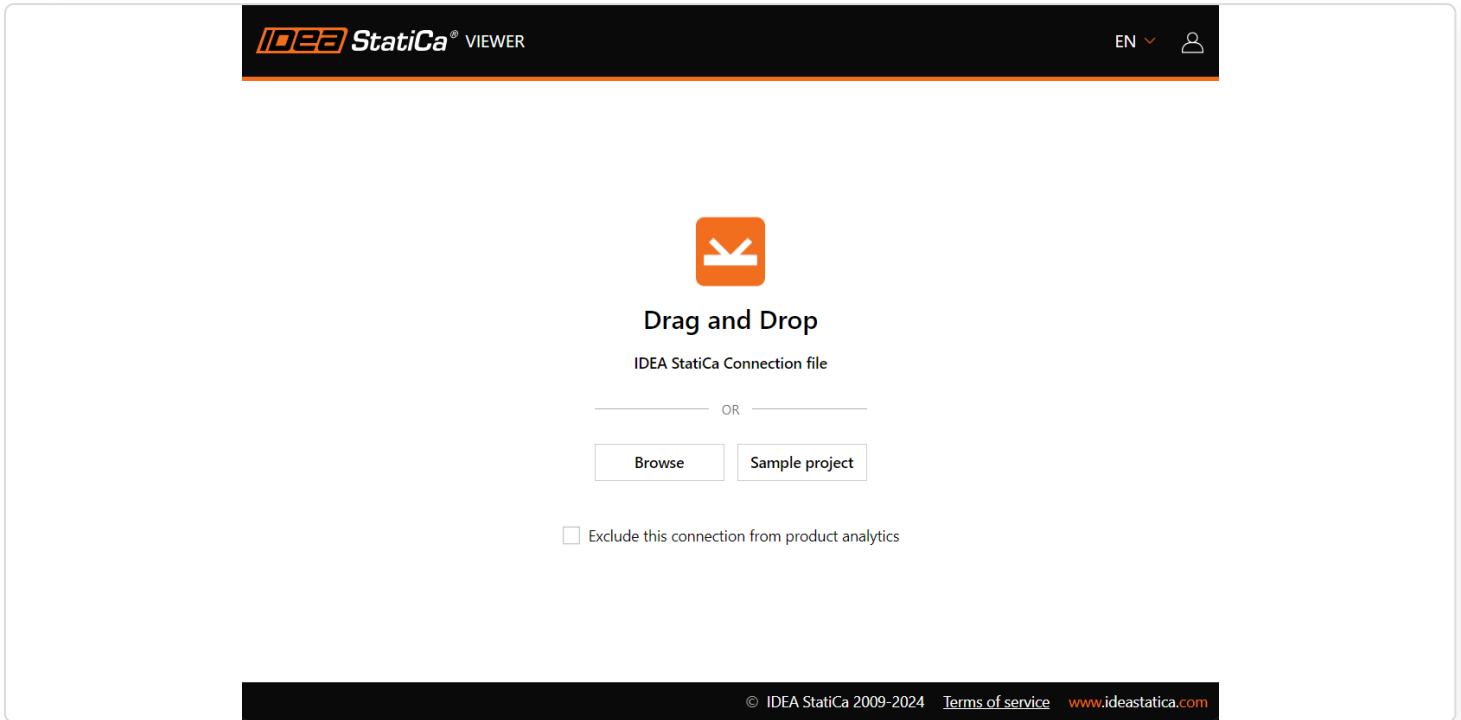

After dropping the model into an Internet browser window, the 3D scene shows all the components of the connection model. If users want to share the link, export the model as a DWG or IFC, or simply browse through the detailed information about the model's components, they need to be signed in.

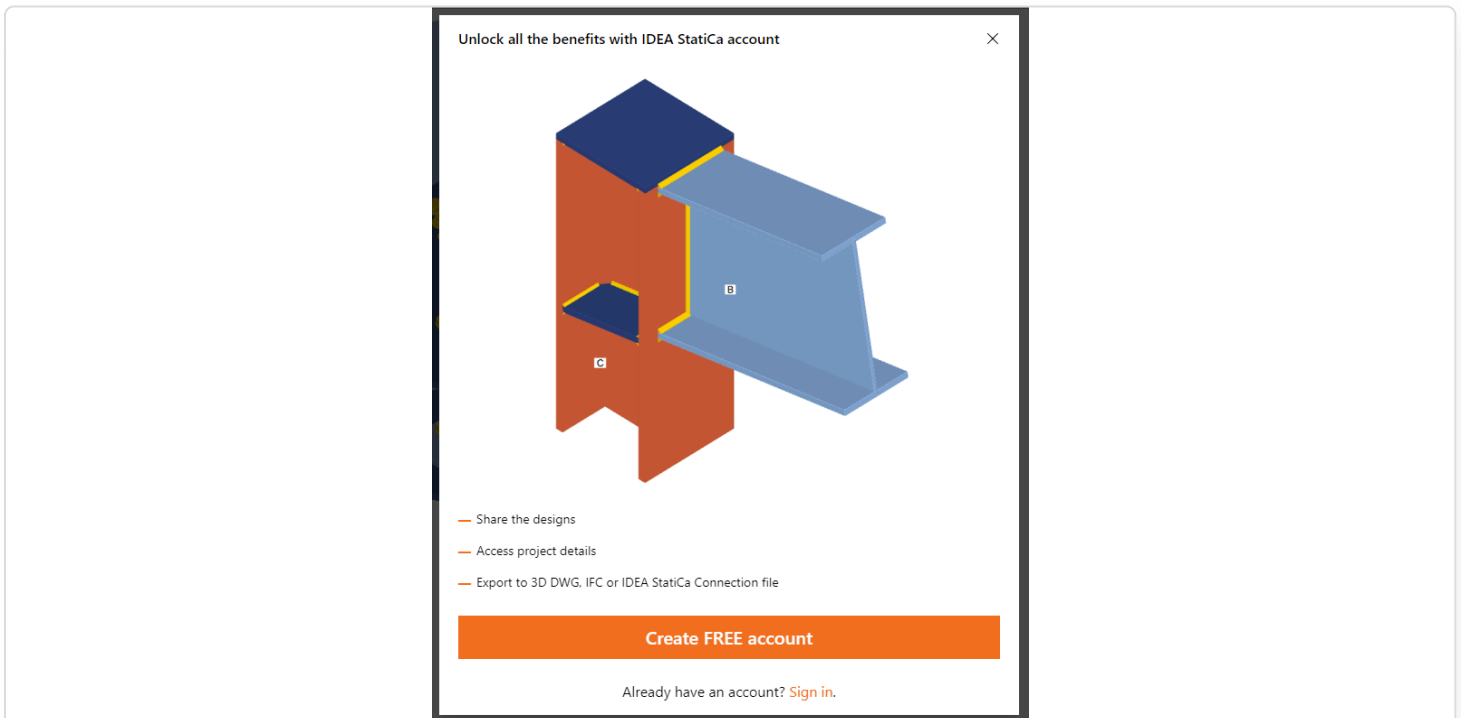

If a current IDEA StatiCa account hasn't been created yet, it is sufficient to create a free Basic account according to this [simple guided process](#).

The top ribbon offers several essential options

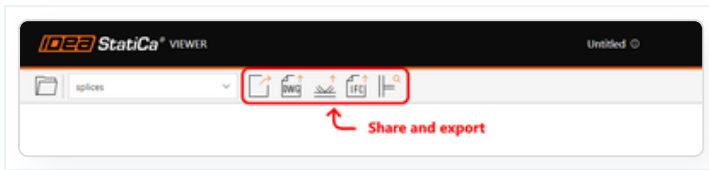
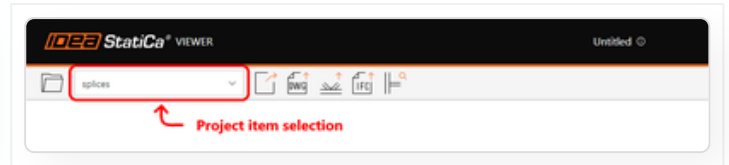
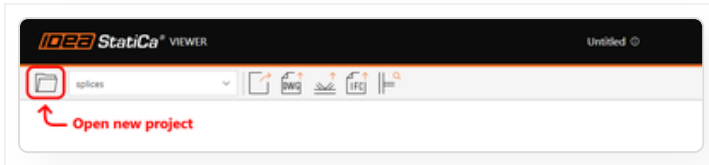

Exporting options in Viewer

- **Share:** One of the easiest ways to share the model information is to use the URL link directly to the Viewer web page with the model already uploaded. This button copies the URL link, which will be stored on the cloud server permanently, so the link can be kept and referred to in the designers' communication for the whole length of the project.
- **Export to 3D DWG:** Exports the 3D model in DWG file format with solid 3D elements and breaks down all plates into separate 2D line blocks.
- **Export to IDEA StatiCa:** This option creates and downloads the model in .ideaCon file format according to the current IDEA StatiCa version.
- **Export to IFC:** Exports the 3D model in IFC (Industry Foundation Class) file format.
- **Explore in Connection Library:** This option launches the IDEA StatiCa [Connection Library](#) web page and offers hundreds of possible alternatives to the current arrangement. The filtering in Connection Library is preset according to the arrangement of the currently opened model in Viewer. The arrangement follows the number of members and their geometry with specific cross-section types.

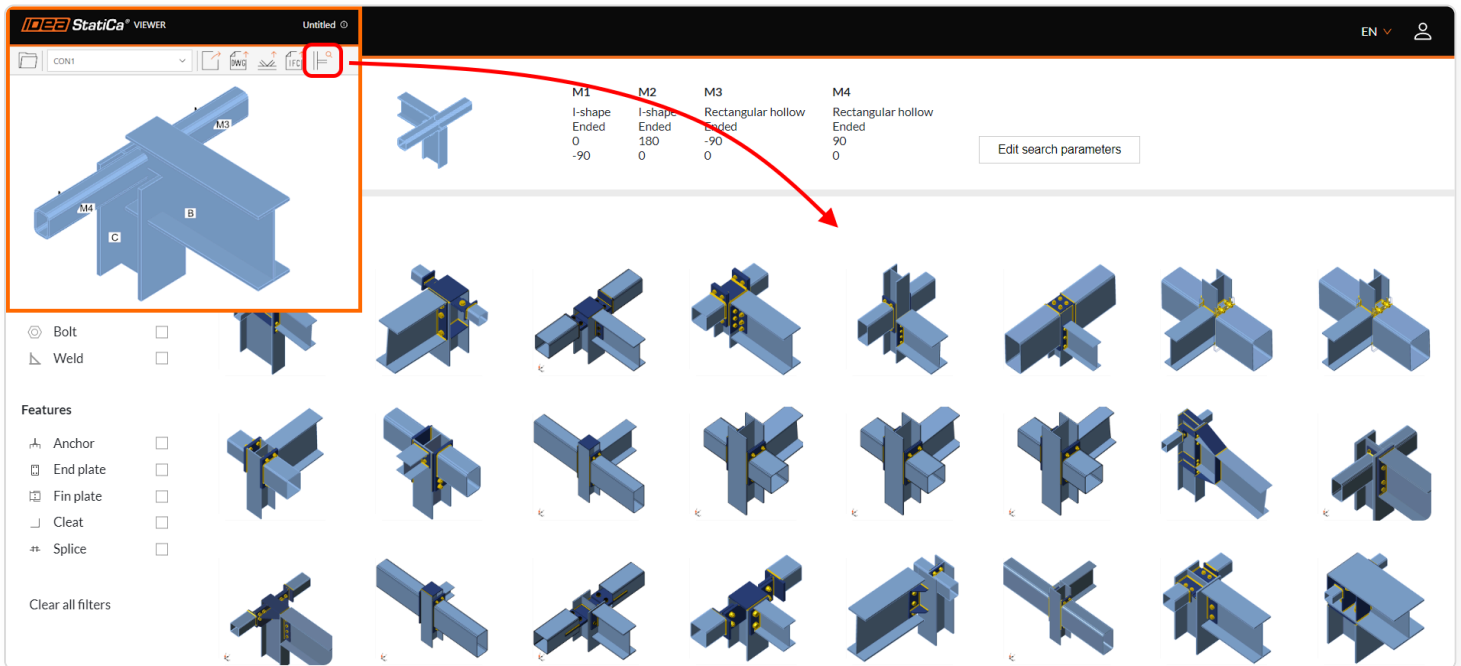

After finding a valid connection design solution, the user can open the specific design back in the Viewer tool.

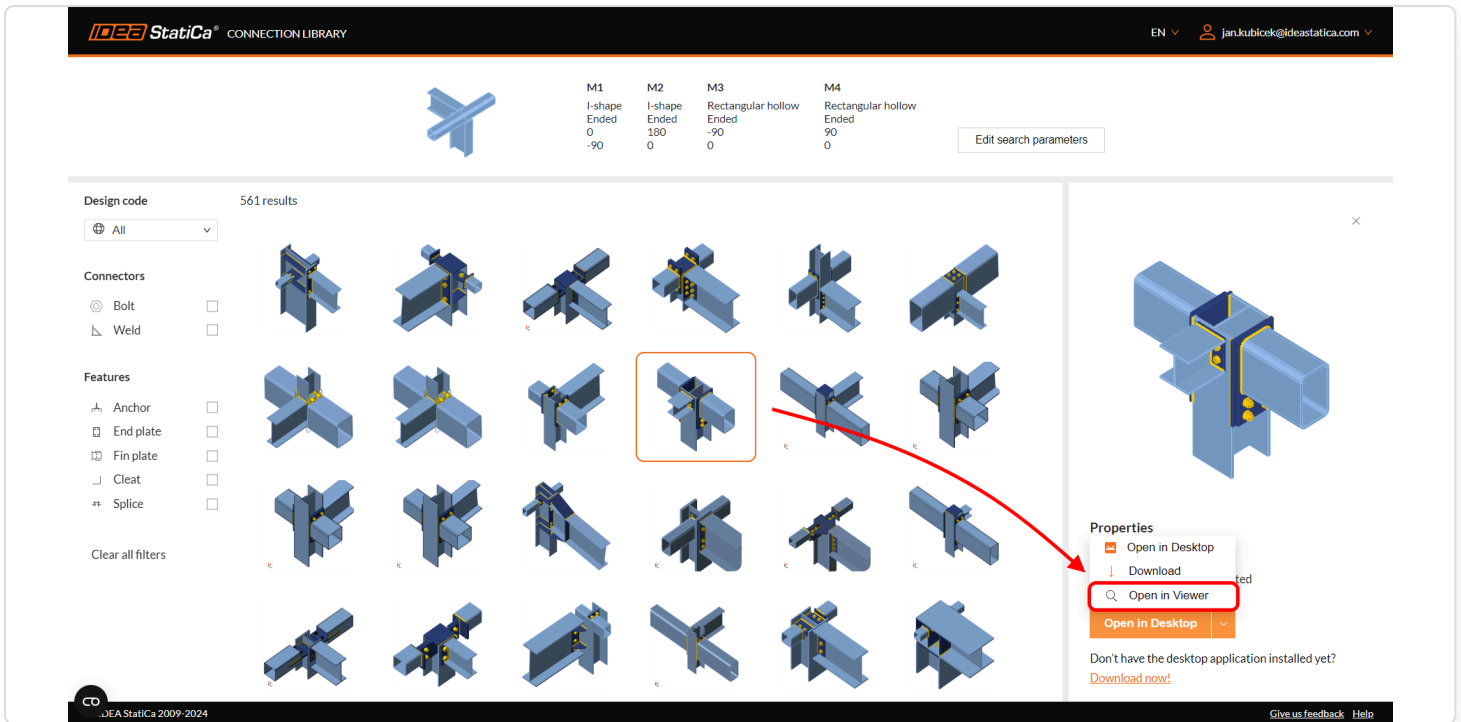

Besides these options, the project parameters can be displayed by clicking the info button at the top of the browser window.

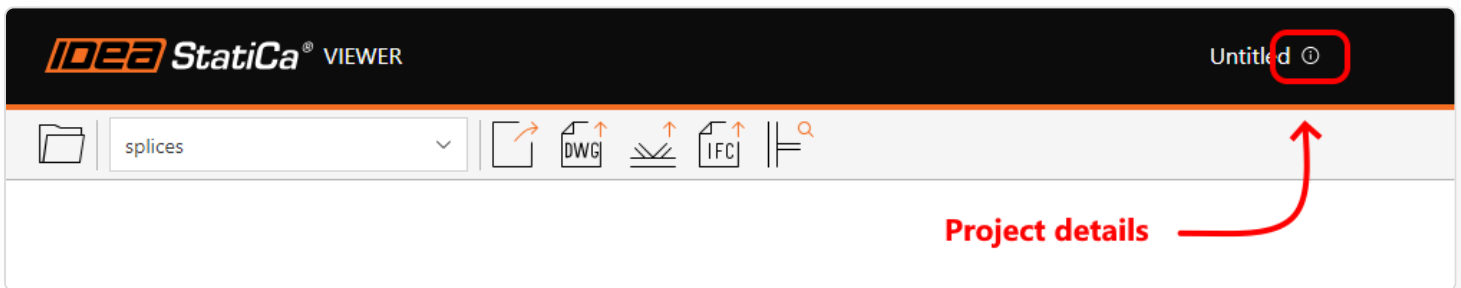

Additional model properties

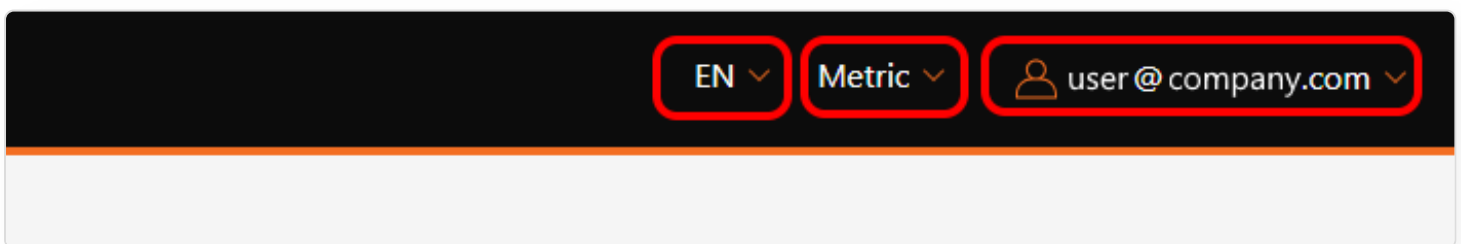

The inclusion of parametric templates in the Connection Library represents a significant advancement in the design process for connection designers. This functionality simplifies the design process by providing:

- **Language selection:** Two options are available – (EN) English and (CZ) Czech
- **Units:** Switching between Metric and Imperial units is available
- **User login:** Link management and Sign-in/Sign-out.

Link management

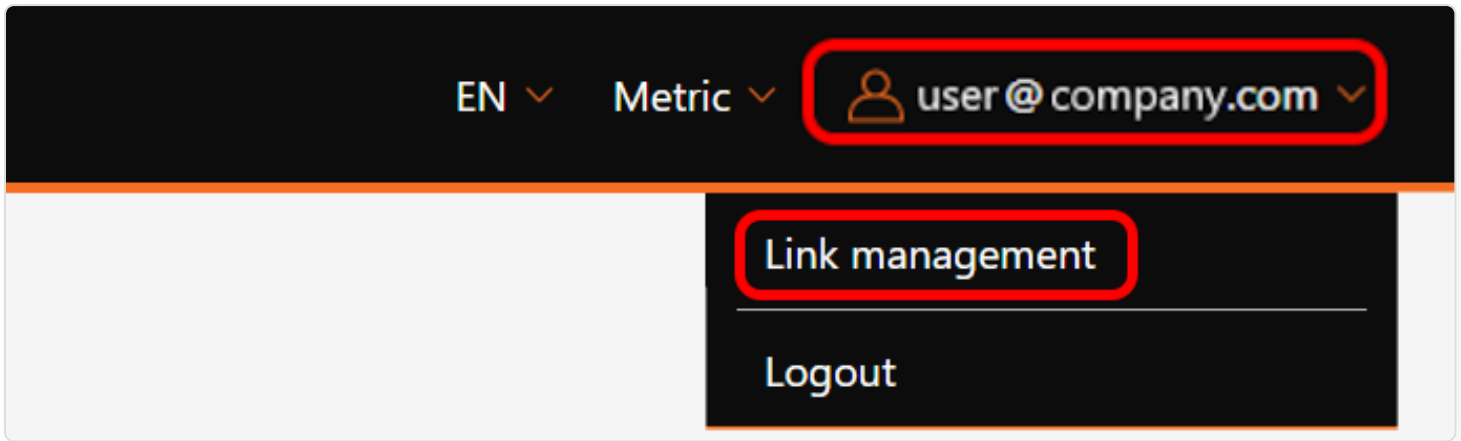

This tool provides the management of used URL hyperlinks. Users can browse through their own links or the ones shared with them. There is also an option to delete obsolete links (in Actions) that are not useful anymore.

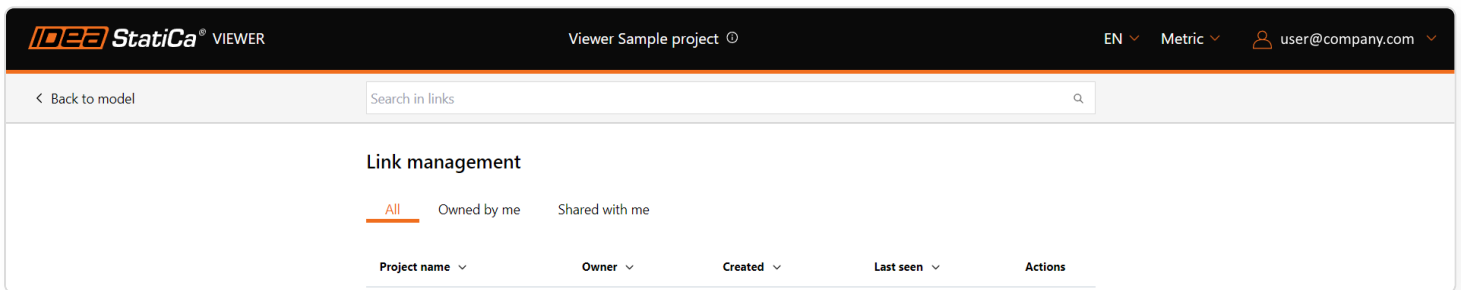

The Property panel

In the right part of the screen, a whole set of model parameters is stored.

Connection space coordinates

After selecting the connection name (Project item) in the tree, two parameters are displayed: the Name of the item and the Connection point.

These coordinates indicate what is the spatial position of the connection node. For models created from scratch in the Connection application, the position will be zero in all directions. However, for models coming from the Checkbot application, the values will follow the spatial position of the node within the whole structure.

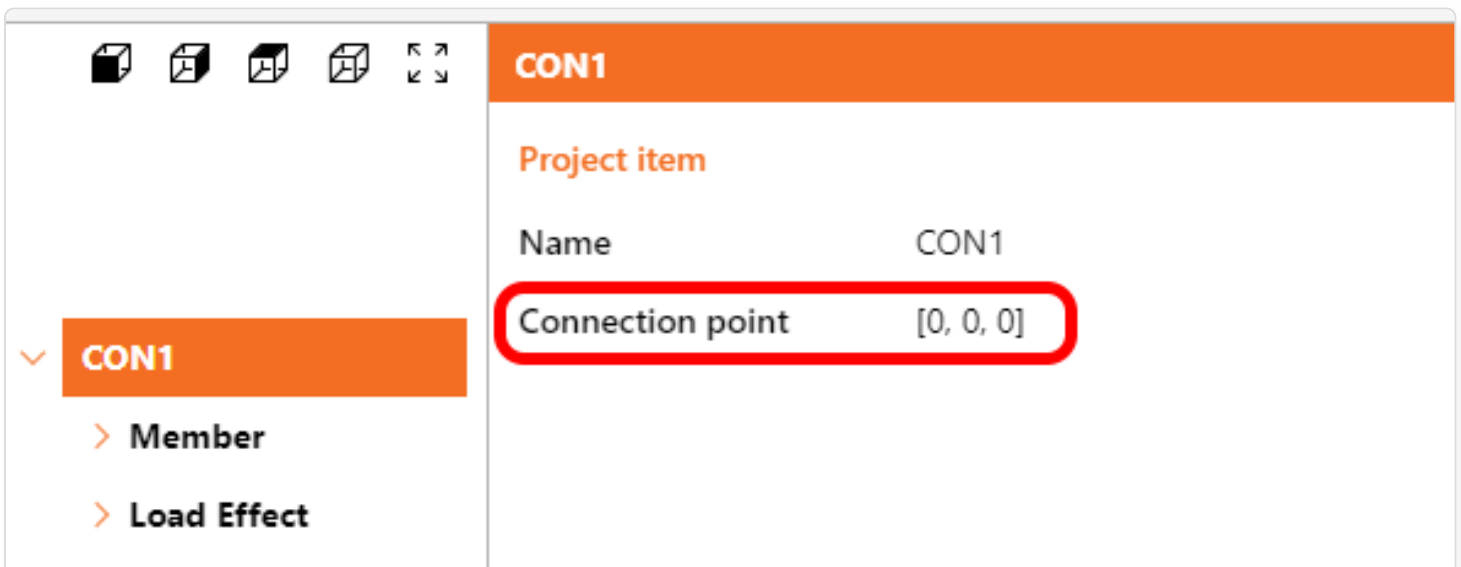

Load Effects

Besides information about the component materials and sizes, unique and important information about how the connection is loaded can be found under 'Load Effects'.

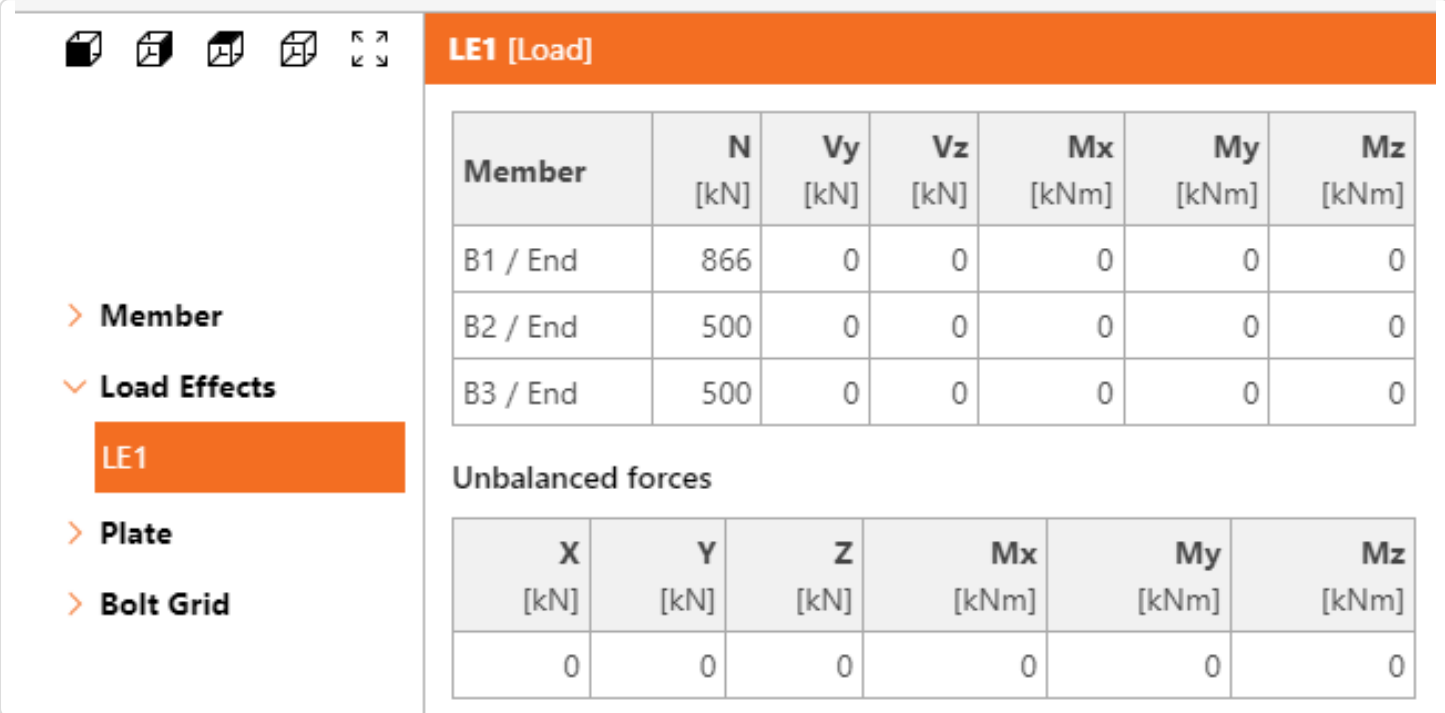

LE1 [Load]

Member	N [kN]	Vy [kN]	Vz [kN]	Mx [kNm]	My [kNm]	Mz [kNm]
B1 / End	866	0	0	0	0	0
B2 / End	500	0	0	0	0	0
B3 / End	500	0	0	0	0	0

Unbalanced forces

X [kN]	Y [kN]	Z [kN]	Mx [kNm]	My [kNm]	Mz [kNm]
0	0	0	0	0	0

Together with load values, other crucial design information is also visible: **Model type** and **Force position**.

Weld properties

The right panel also contains information about the weld type:

- fillet (single/double-sided)
- butt weld
- partial joint penetration

with visual representation in the 3D scene also for:

- continuous
- partial length
- intermittent welds

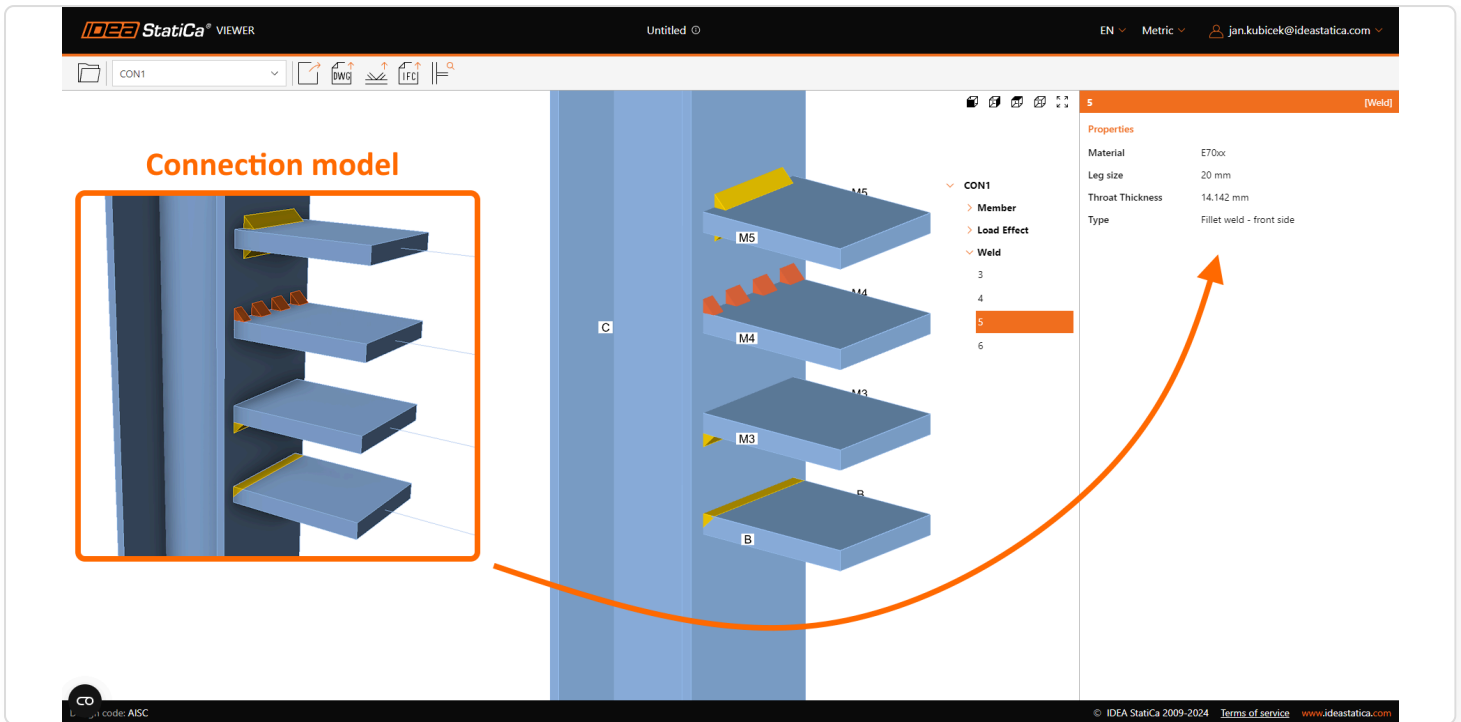

For clarity of outcomes, both values of weld size are displayed at the same time – Leg size and Throat thickness, independent of the units selected.

Connector properties

Additional information is displayed for different connector types:

Pins:

- Material
- Diameter

Anchors:

- Anchor name
- Diameter
- Anchoring length
- Shear plane in thread
- Anchor type
- Washer size

Bolts:

- Bolt assembly name
- Diameter
- Shear plane in thread
- Shear force transfer type

Element detail drawing

Detailed drawings of specific cross-sections and plates are displayed in an additional graphics window with their basic dimensions. For profiles and models with more complex plate shapes and overly dense dimension lines, there is an additional option to open an enlarged vector drawing in a new sub-window.

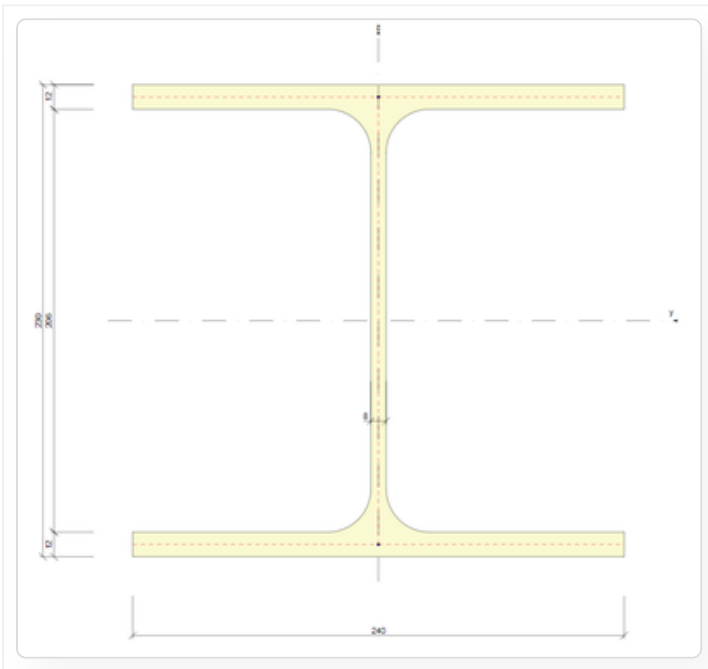
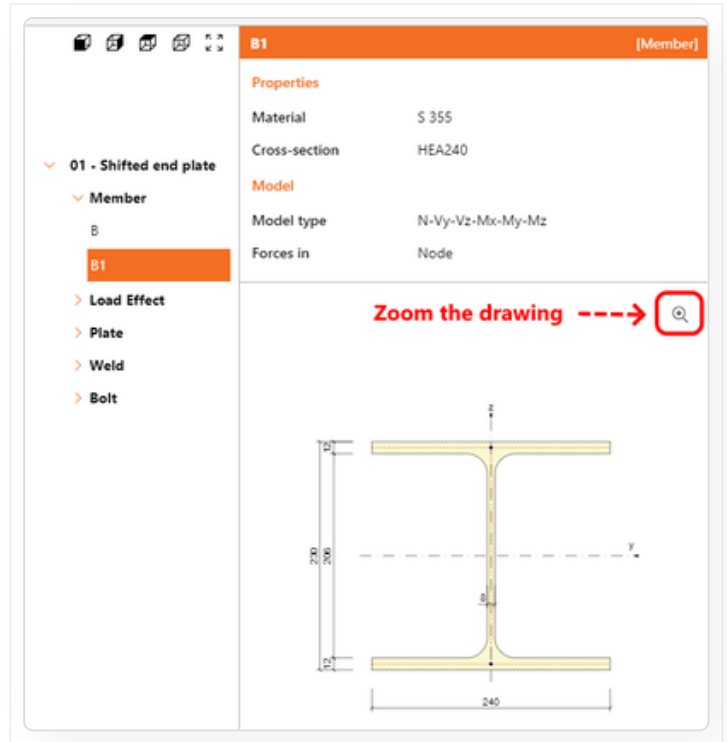
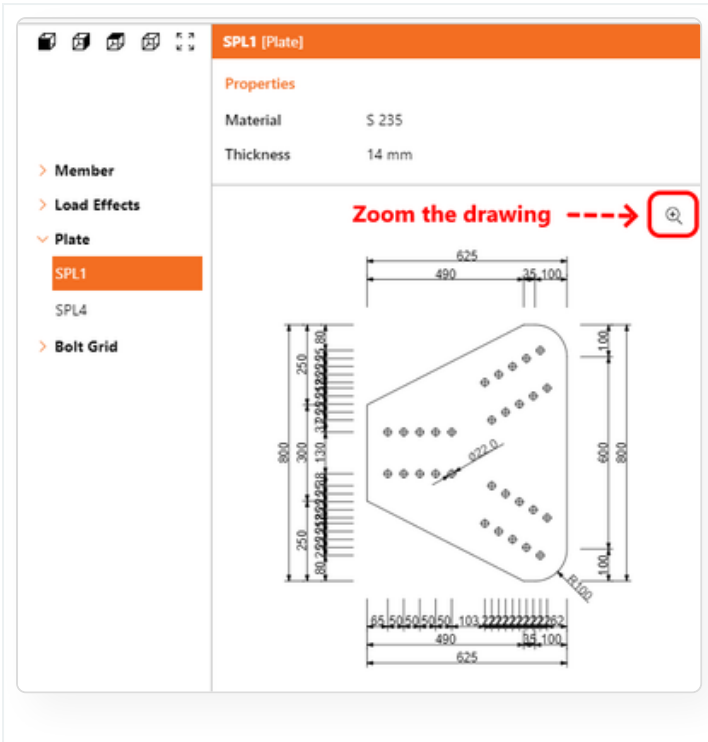

Released with IDEA StatiCa 24.1.

Foundation block

The navigation tree category - 'Foundation block' - provides information about anchoring parameters and material properties considered in the design.

Once the project model contains a concrete block, the following list of information is displayed:

1 [Foundation block]	
Properties	
Concrete grade	C30/37
Offsets	300 mm
Depth	800 mm
Stand-off	Mortar joint
Thickness	30 mm
Shear force transfer	Shear lug
Shear lug	
Cross-section	HEB200
Length	150 mm
Position	0 mm
Rotation	0°

If the Shear force transfer is set to 'Shear lug', these parameters are also provided.

Response time of Viewer

Together with new model information, version 25.0 brings a huge reduction in response time, mainly with more complex models. In comparison to version 24.1, the model is uploaded and ready to work 2x faster, while the properties data are available 15x faster, which means a model is ready for investigation in seconds.

Released with IDEA StatiCa 25.0.

Enhanced User Portal

The IDEA StatiCa User Portal is the space for maintaining a user's relationship with IDEA StatiCa and its products. It enables the administration of licenses, analytics about tool usage, and shows progress in Campus courses, all in one place.

Key features of the User Portal environment

- User-oriented content is shown in the main platform
- Clear communication of expired licenses
- A **concise dashboard** with important data in one place:
 - Account details
 - Reseller info
 - Easy-to-use **helpdesk case** management
 - Access to the IDEA StatiCa **courses e-learning platform**
- A side menu also makes it easy to:
 - Browse through **License analytics** with the product usage overview
 - Access the cloud tools **Connection Library** and **Viewer**

New portal layout

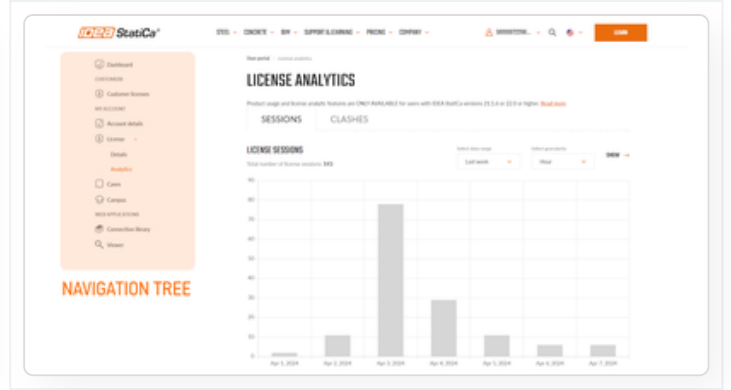
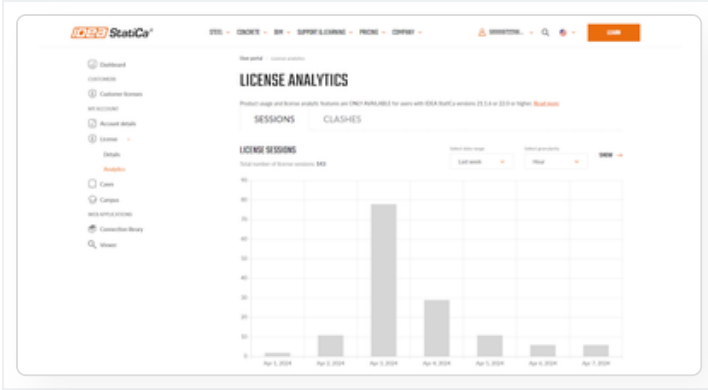

Besides administration purposes, links to IDEA StatiCa cloud tools are present there as well.

Released in IDEA StatiCa version 24.0.

Self-service tools for license admins

User deactivation by the license administrator

The User Portal provides the possibility for license administrators to Activate and Deactivate the users within their company license pool.

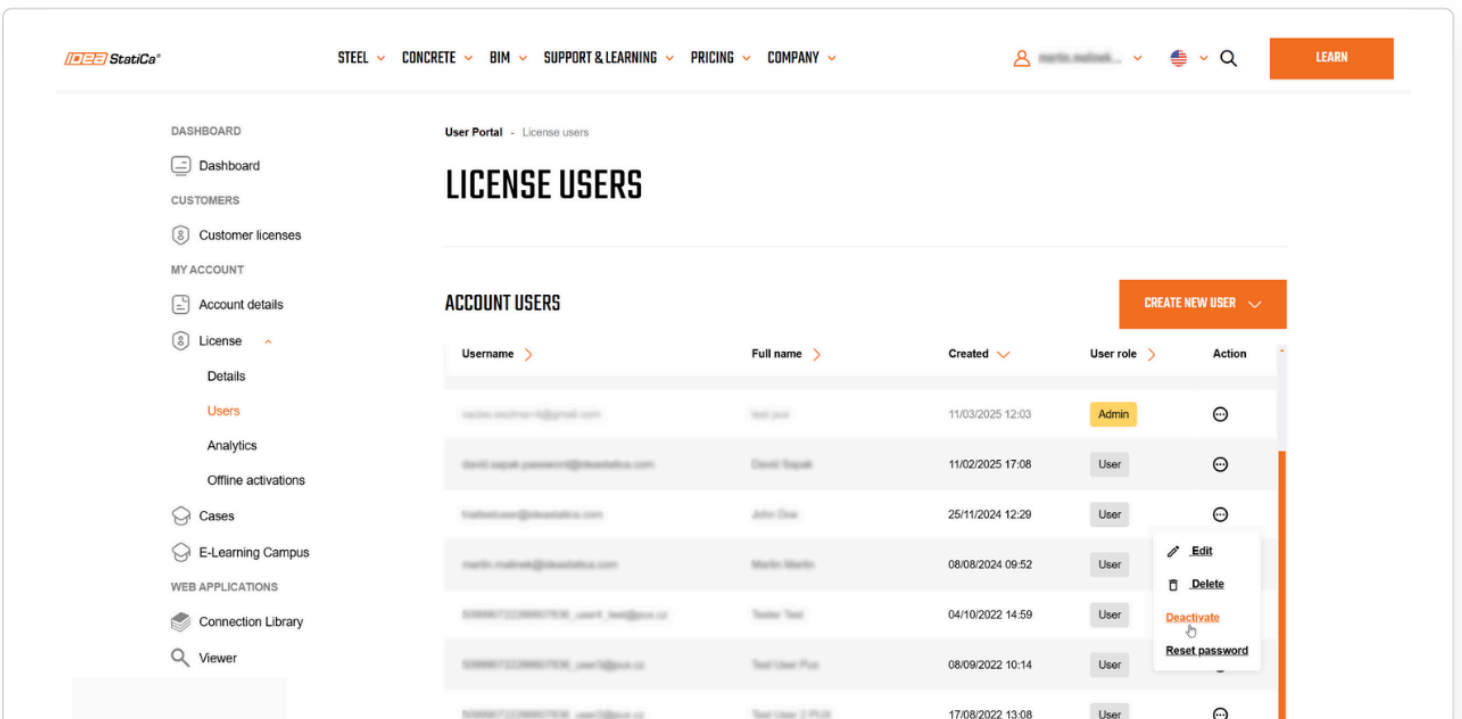

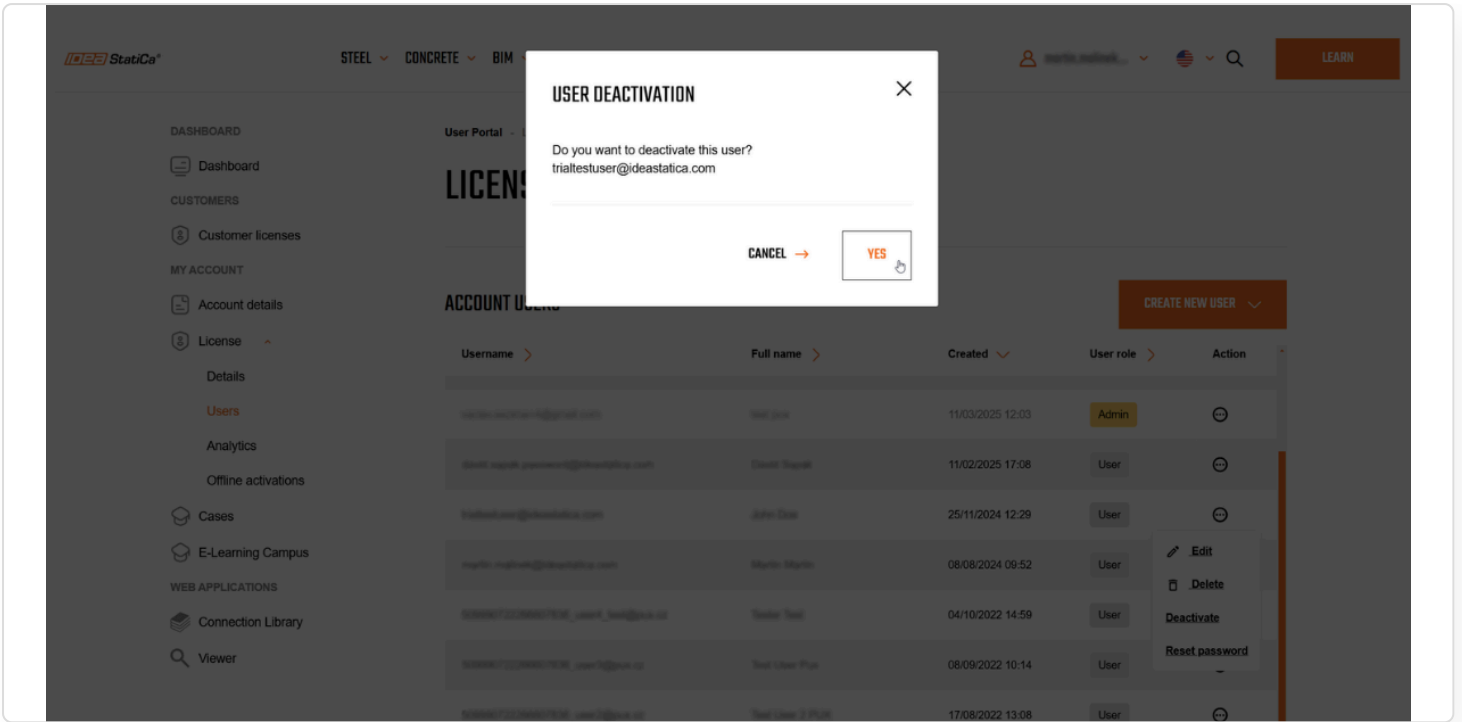

The Dashboard shows a clear list of license users, where the current status is visible based on text color.

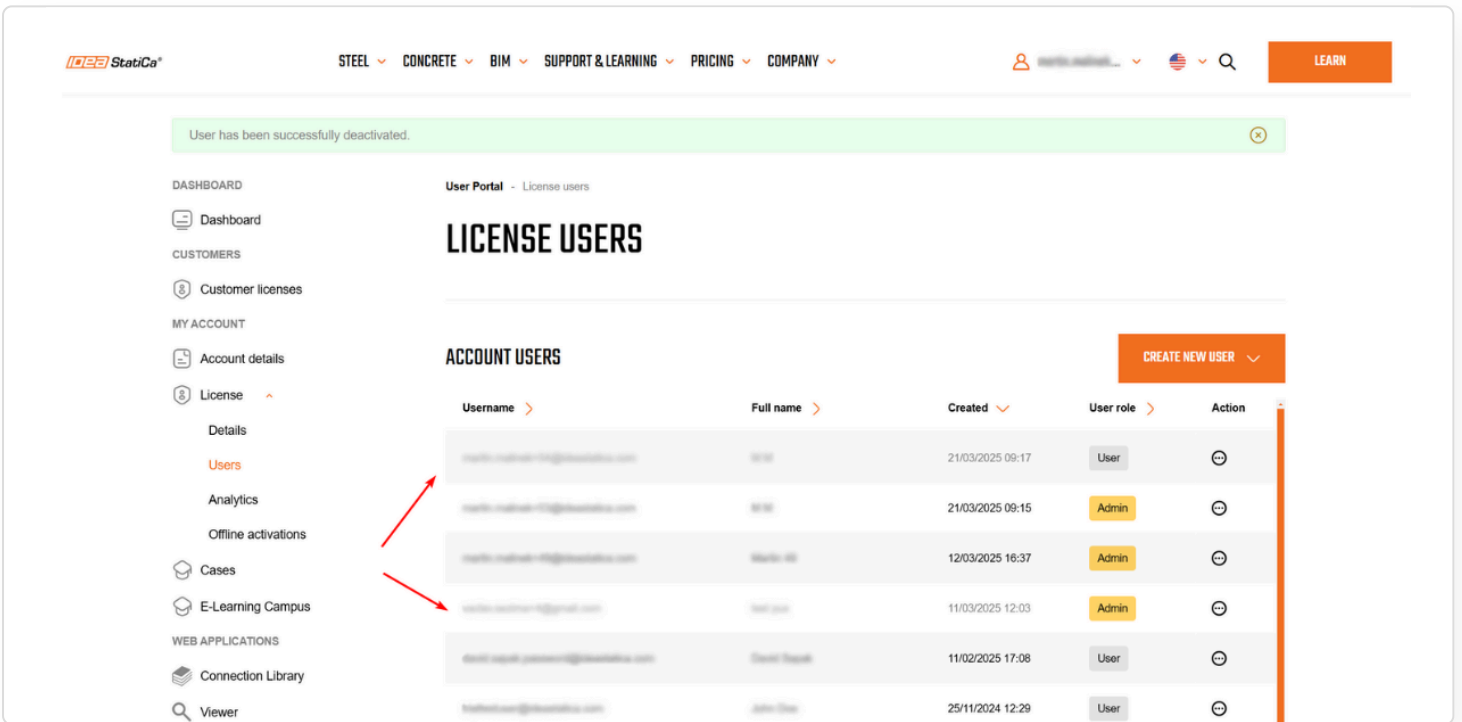

Password verification for users created by a license administrator

There is data security provision through new password verification for newly created users' accounts.

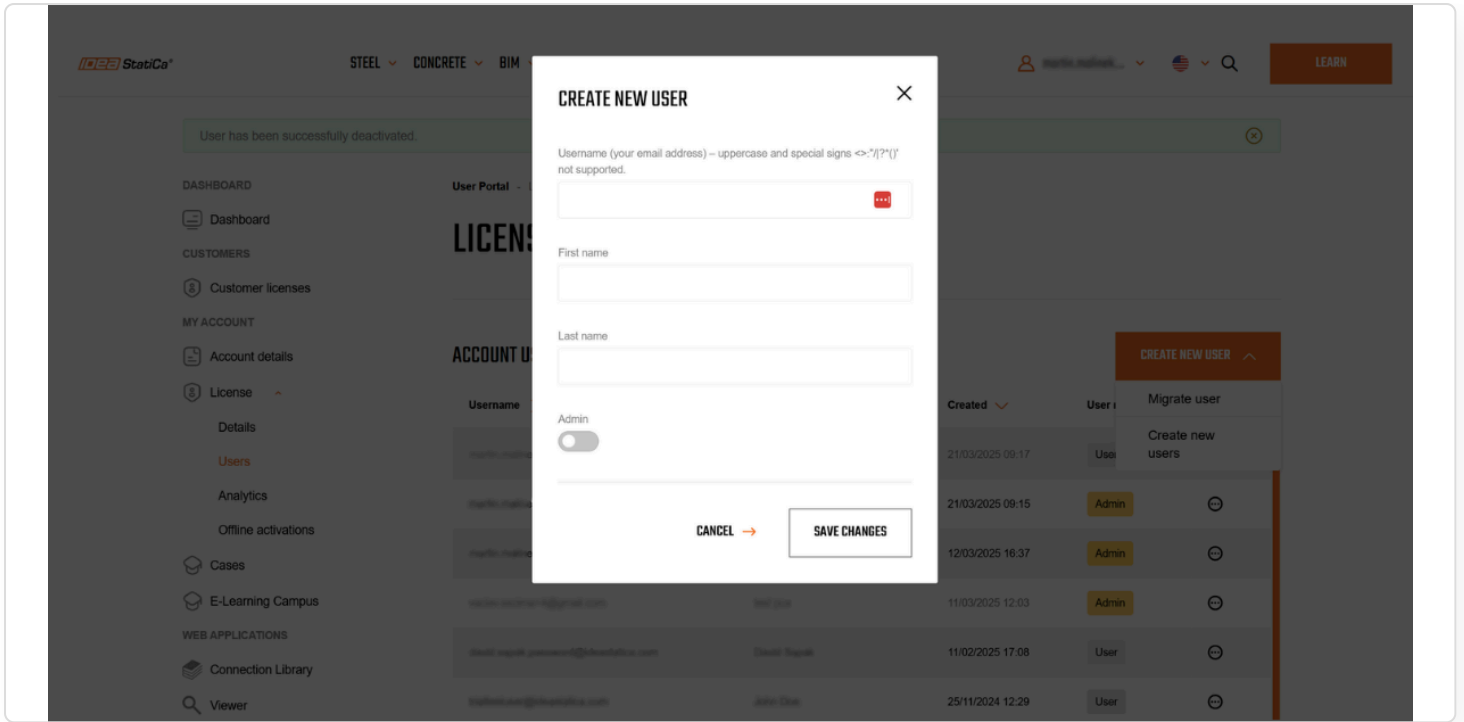

There is no need to send the new password from administrators to new users through unsafe copy/pasting. The new user will create their first password through an email confirmation link during the first launch process.

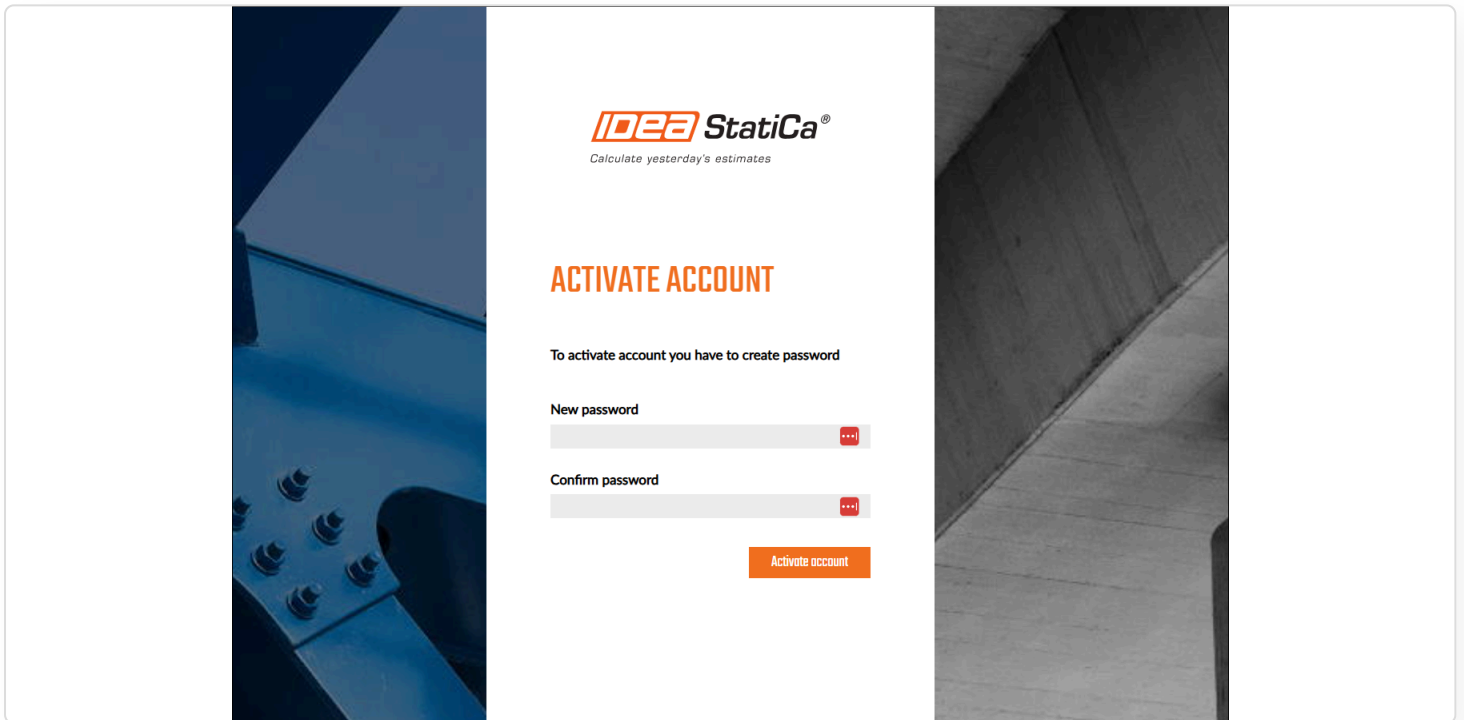

Password resetting by a license administrator

Another security self-service feature allows a license administrator to reset the license user's password in case it was forgotten or the credentials have been compromised.

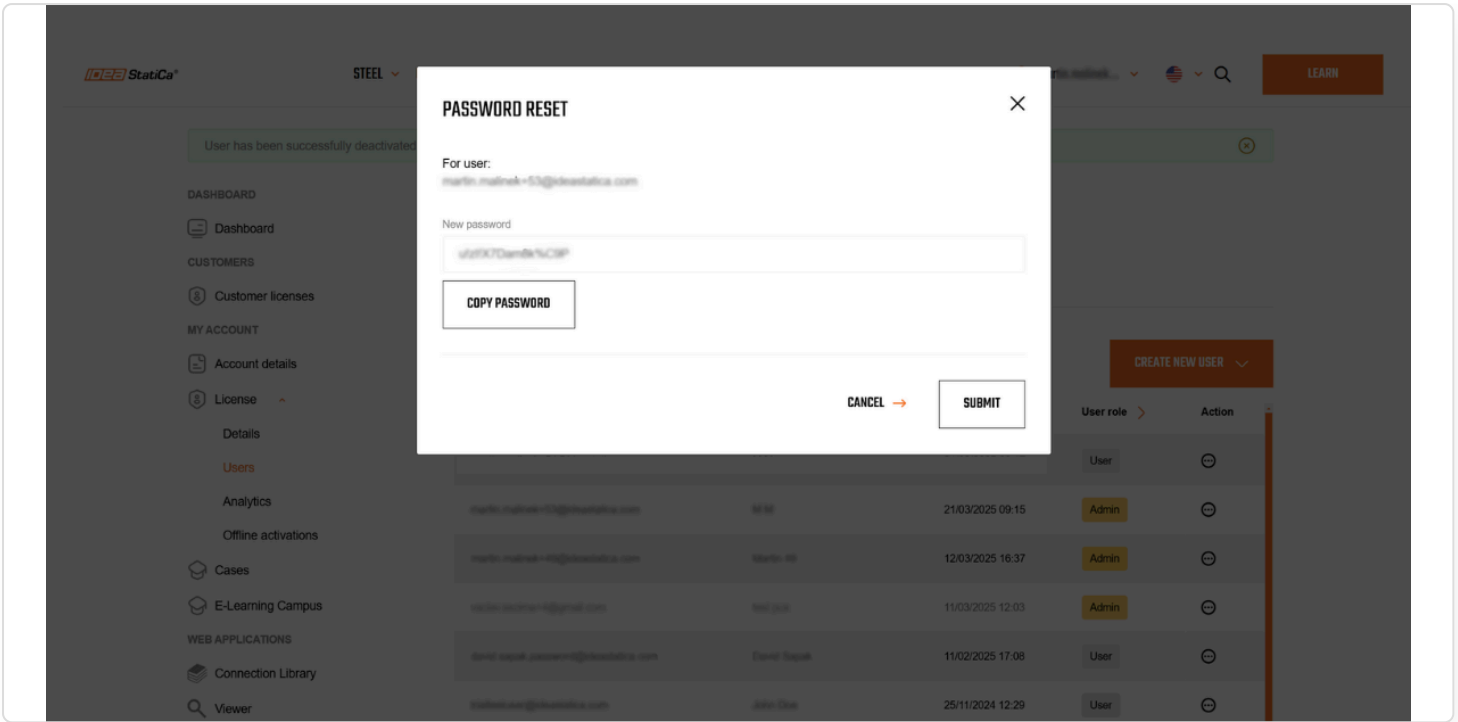

User account migration

In cases where IDEA StatiCa users work on different types of licenses (commercial, trial, educational), the company license administrator can migrate the users' accounts under the main company license.

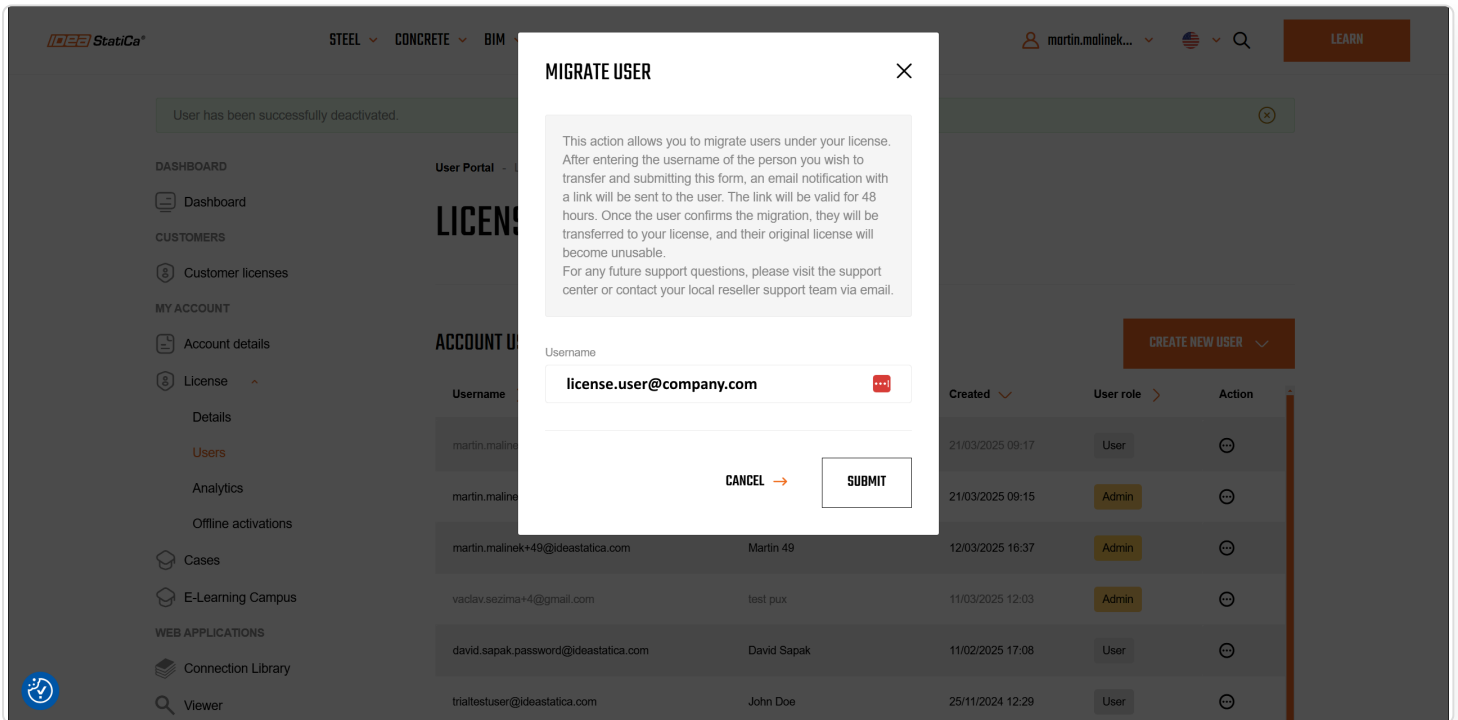

This process is completely manageable on the side of the customer without the necessity of contacting IDEA StatiCa support. The migrated user gets a confirmation notification about being added to the company license pool of users.

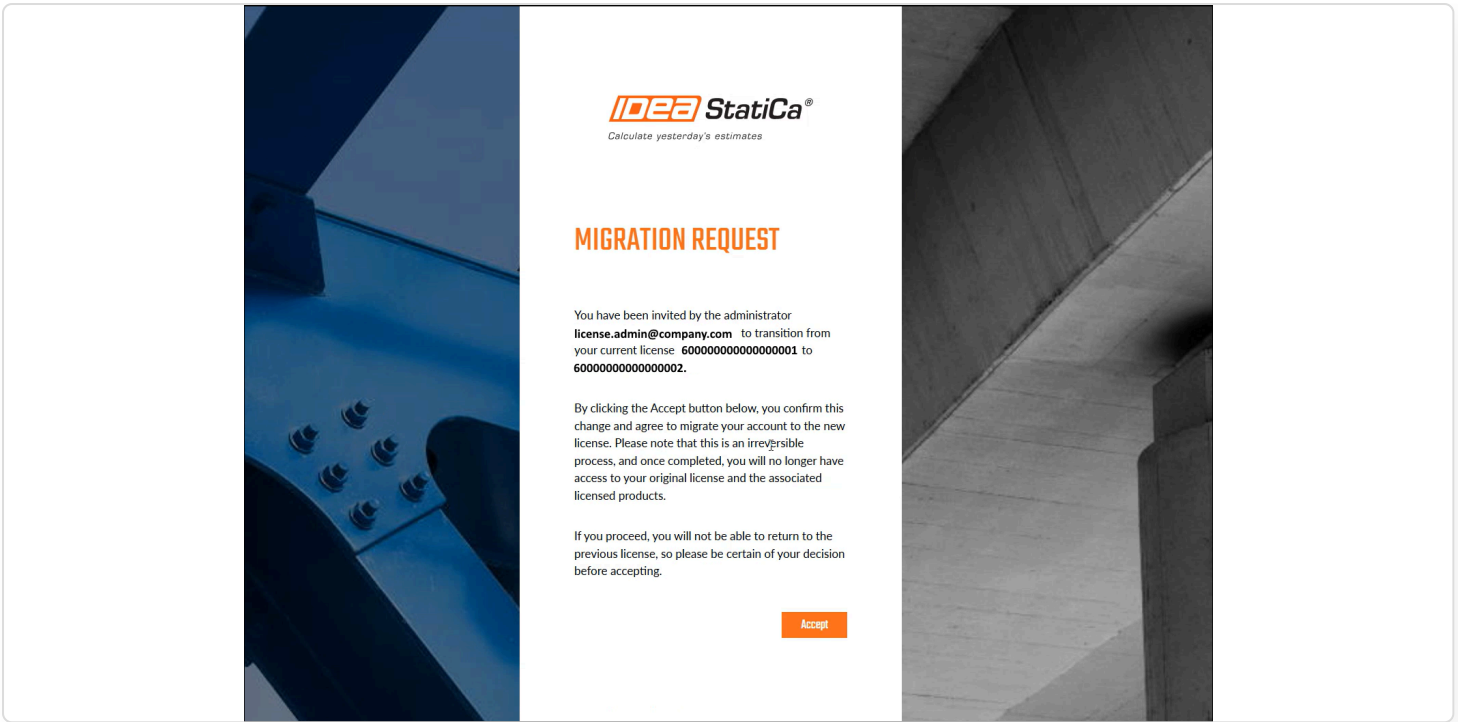

A user's branch office selection

For Enterprise license customers who are sharing the license pool across several offices, this functionality allows the license administrators to set the proper branch office for every license user. This helps the companies to track the usage of the licenses or number of support cases reported.

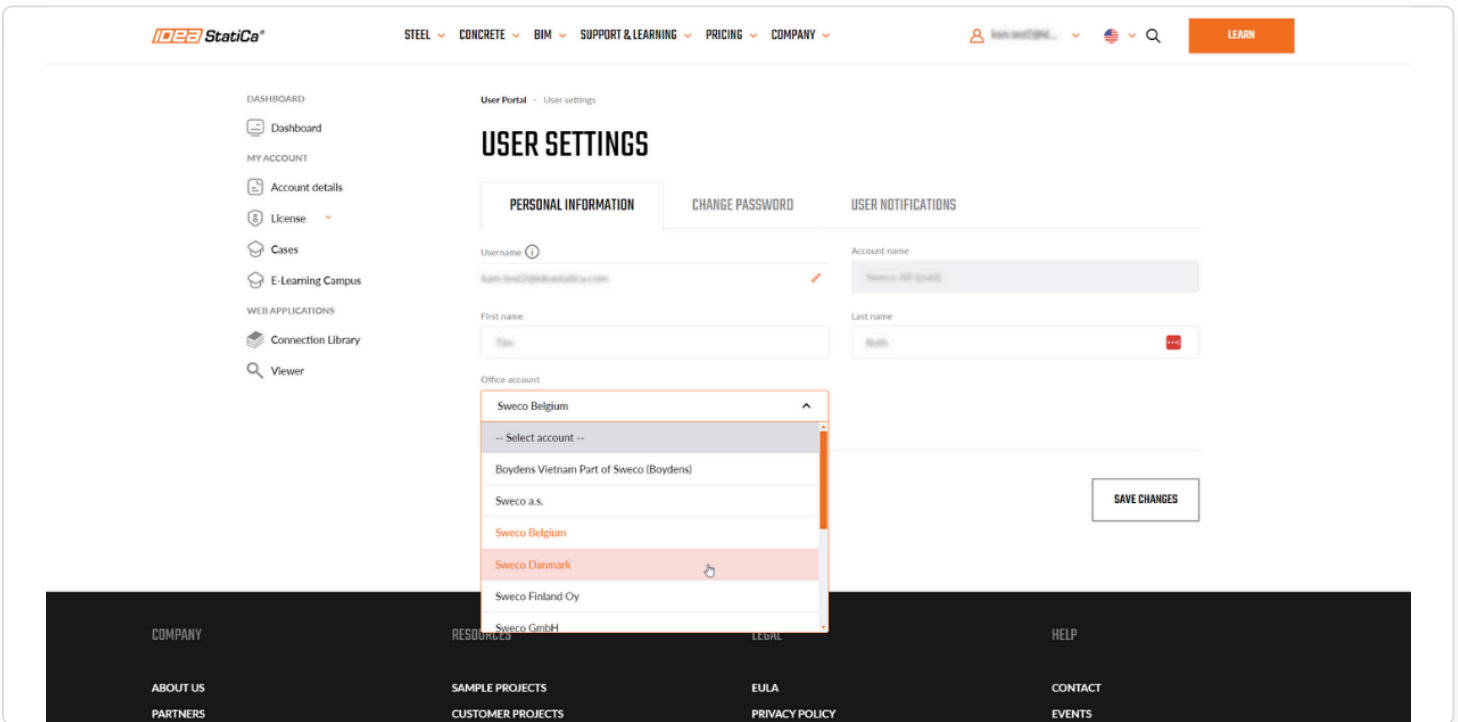

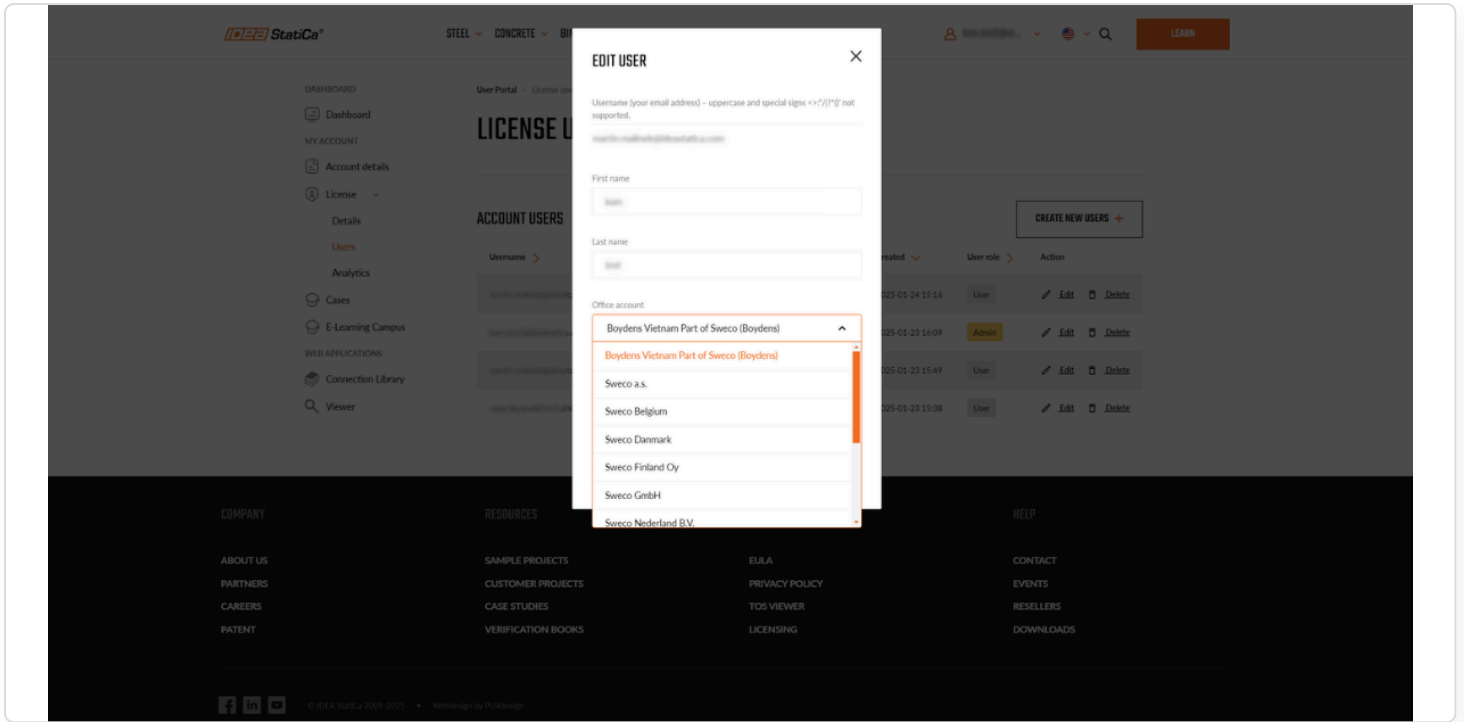

Besides clearer user management, this also leads to a time reduction in the processing of cases, as the proper support office can be selected faster on the side of IDEA StatiCa support.

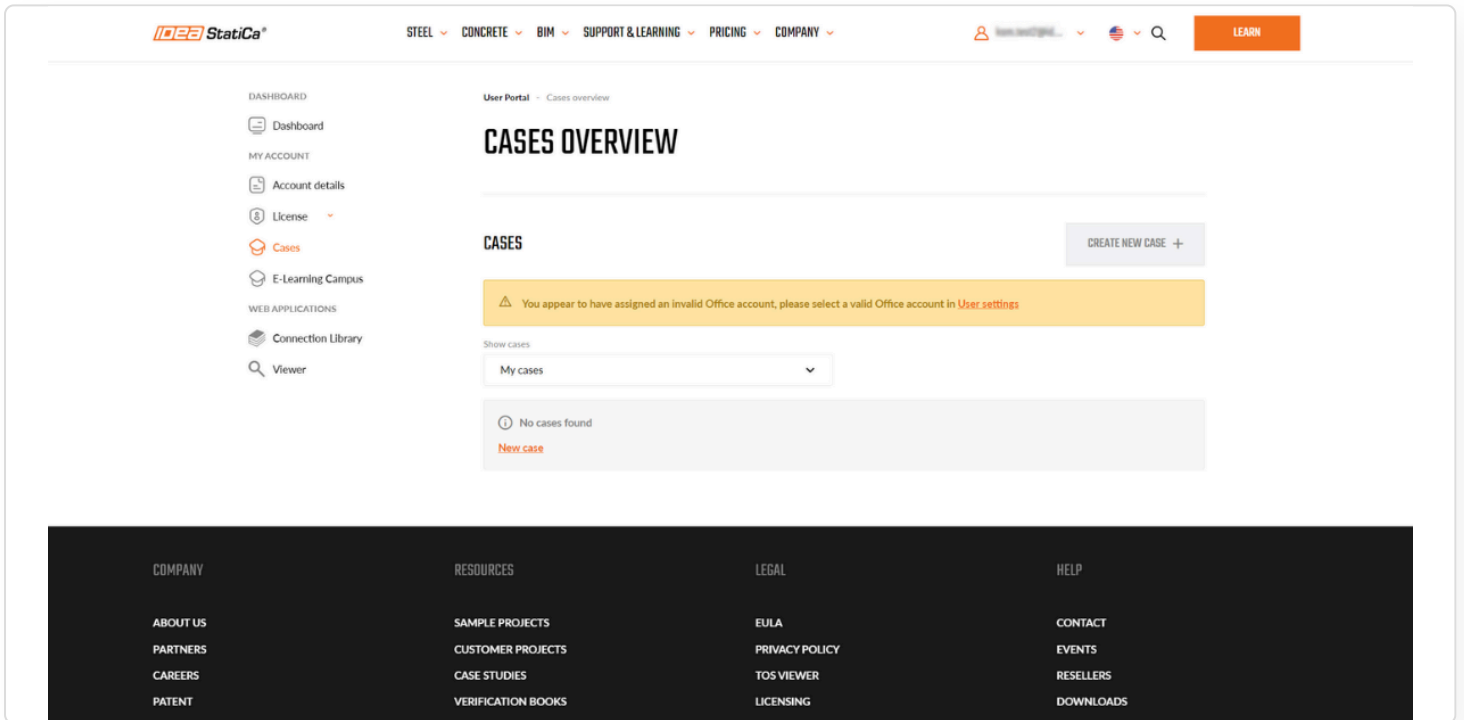

Users' activity score

These score categories allow users to participate in IDEA StatiCa development through Beta testing or Feature request reporting. In addition, it enables the personalization of online content suggested to specific users.

WHAT YOU GET WITH EACH LEVEL



SILVER - 0 POINTS

- Access to the User Portal
- Invitations to special events of our resellers or branches
- **Access to our free apps:**
- [Connection Library](#)
- [Viewer](#)



GOLD - 1,000 POINTS

- Become a beta tester for IDEA StatiCa software
- Gain access to new improvements
- Contribute to software development with your feedback

[BECOME A BETA TESTER →](#)



PLATINUM - 1,500 POINTS

- Your suggestions go directly to our product owners
- Participate in the development of IDEA StatiCa software
- Share any ideas you think might be useful
- Be part of the process that shapes future updates

You don't have enough points for this

[FEATURE PROPOSAL →](#)

How the IDEA Activity Score is calculated

Engagement:

- Website activity
- Interacting with IDEA StatiCa emails
- Completeness of a user's profile

(A maximum of 1,000 points can be earned in this category)

Education:

- Attending training or workshops: 300 points per event.
- Successfully completing e-learning courses: 250 points for a completed course. [What you will learn](#)
- In-person meet-ups – Coffee and Learn, User Days, etc. – 80 points per event.
- Attending IDEA StatiCa webinars: 45 points for attending a webinar. [Check out the list of webinars](#)

(There is an unlimited number of points for this category)

Customer success hub:

- Creating a video case study with us – 1,500 points. [Check out the example](#)
- Creating a case study with us – 500 points. [Check out the example](#)
- Creating a customer project with us – 250 points. [Check out the example](#)
- Creating a short testimonial with us – 100 points. [Check out the example](#)

(There is an unlimited number of points for this category)

Using our software

- Actively engaging with IDEA StatiCa's software tools or free tools

(There is an unlimited number of points for this category)

Released in IDEA StatiCa version 25.0.