

## Shear at the Interface between Composite Parts of Prestressed Concrete Section

Jaroslav Navrátil<sup>1, a\*</sup>, Lukáš Zvolánek<sup>2, b</sup>

<sup>1</sup>IDEA RS s.r.o., U Vodárny 2a, 616 00 BRNO, Czech Republic

<sup>2</sup>Faculty of Civil Engineering BUT, Veverí 95, 602 00 BRNO, Czech Republic

<sup>a</sup>navratil@idea-rs.com, <sup>b</sup>zvolanek.l@fce.vutbr.cz

**Keywords:** Composite concrete beams, Eurocode, Design, Construction joint, Shear, Creep, Shrinkage, Stress redistribution

**Abstract.** Composite concrete beams made of prefabricated prestressed or non-prestressed element and cast-in-place reinforced concrete slab became very popular in present-day civil engineering practice. Two concrete composite parts of beam are cast at different times. Different moduli of elasticity, consecutive load application, and differential creep and shrinkage cause unequal strains and stresses in two adjacent fibers of construction joint. The requirement is to ensure that both parts act fully compositely, because the bending and shear designs of composite members are based on this assumption. Therefore the level of shear stresses at the interface between two parts must be limited. The objective of the paper is to review the methods for the calculation of shear stresses in construction joint, and to evaluate the influence of different age of two concrete composite parts on the level of shear stresses. Calculation method alternative to Eurocode 2 method is proposed and tested. It is recommended to calculate the shear stress from difference of normal forces acting on sectional components in two neighboring sections of the element. It was observed that differential shrinkage of concrete components can significantly affect the stress distribution. Numerical studies were performed based on real-life examples of composite beams.

### Introduction

The structures such as floors composed of prefabricated beams made subsequently monolithic by cast-in-place concrete, permanent shuttering floor systems or composite bridge beams prefabricated or cast-in-place utilize different static systems during their construction. The history of construction and service stages influences the ultimate resistance and serviceability limit state of these structures. Special check of shear capacity of construction joint is needed to verify the strength of concrete composite sections and to ensure that concrete components act fully compositely. The shear stress in construction joint is caused by external load and rheological effects.

### Shear at the Interface According to Eurocode 2

Eurocode 2 specifies that the design value of shear stress  $v_{Edi}$  at the interface between two composite parts of beam should be checked to ensure it is smaller or equal the design shear resistance at the interface  $v_{Rdi}$ . The design value of shear stress is given by the equation (6.24) of clause 6.2.5

$$v_{Edi} = \beta V_{Ed} / z \cdot b_i. \quad (1)$$

$V_{Ed}$  is the shear force,  $b_i$  is the width of the interface, and  $z$  is the lever arm of composite section. Using EC2 wording  $\beta$  is the ratio of the longitudinal force in the new concrete area and the total longitudinal force either in the compression or tension zone, both calculated for the section considered. Both lever arm  $z$ , and  $\beta$  factor are worth detailed discussion. The design shear resistance is not discussed in this paper.

As a simplification it is generally accepted to use the same value of lever arm as obtained from ultimate bending resistance, which overestimates actual lever arm, see Fig. 1. Nevertheless for correct solution the lever arm  $z$  should reflect the flexural stress distribution in the section and loading considered. In this case the stress-strain response of the section is governed by ultimate limit state (ULS) conditions assuming that the tensile strength of the concrete is ignored and the stresses in the concrete in compression and stresses in the reinforcing or prestressing steel are derived from the design stress-strain relationships.

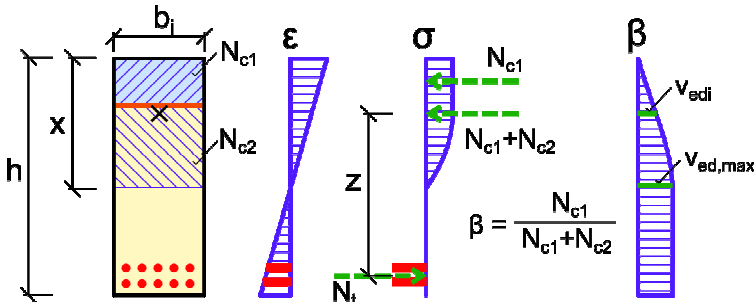

Fig. 1 Calculation of Shear Stress in Construction Joint Using the  $\beta$  Factor

By way of  $\beta$  factor the shear stress for design at the interface is related to the maximum shear stress at neutral axis given by  $V_{Ed}/zb_i$ . In case that the distribution of normal stresses is linear, the formula (1) corresponds fully with well-known Grashof's theory. If the plane of construction joint lies within unbroken either compression or tension zones and the distribution of normal stresses is non-

linear, the shear stress at the interface can still be reduced by the  $\beta$  factor despite the fact that stress distribution does not meet Grashof's assumptions, see Fig. 1.

The problem arises from the effect of differential creep and shrinkage of concrete. In such case there is a discontinuity in the distribution of normal stresses (first derivative of stress does not exist) at the interface, see Fig. 2. It is questionable to which extent we can apply formula (1) for shear stress calculation.

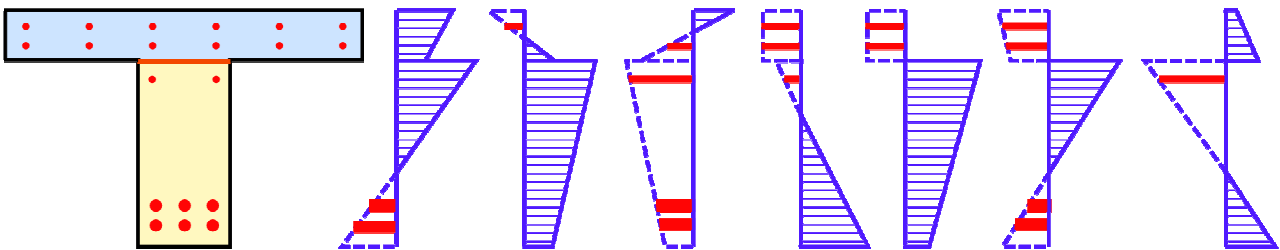

Fig. 2 Various Distributions of Normal Stresses with Discontinuities

As a result of stress redistribution in the cross-section due to creep and shrinkage, separate compression and tension zones may appear in both parts of cross-section, see Fig. 3. In such situation the application of formula (1) might cause significant errors in shear stress calculation.

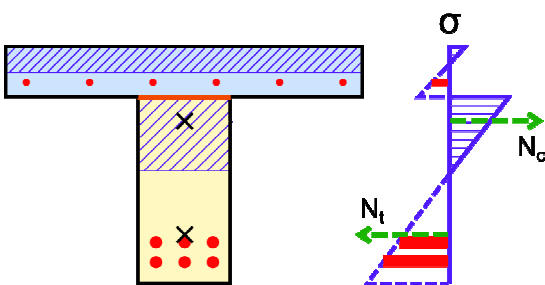

Fig. 3 Separate Compression and Tension Zones in Composite Section

Let us assume that we integrate the stresses in all parts of compression zone and in all parts of tension zone. We obtain resultant forces in compression and in tension respectively. Their positions define lever arm, which can significantly differ from standard case shown in Fig. 1. For example tensile zone in the slab moves total resultant in tension towards resultant in compression and therefore decreases lever arm. The use of such lever arm in the formula (1) would be incorrect. Stress distribution in the section does not correspond with the assumptions of

Grashof's theory. Therefore the formula (1) does not reflect stress redistribution in the cross-section caused by consecutive construction, and differential creep and shrinkage of concrete of both

composite parts of cross-section. The situation is complicated even more in the case of double bending. In such cases it is recommended to consider conservative value of  $\beta = 1.0$ . The study below confirmed that relative error in calculating shear stress  $v_{Edi}$  in such cases can reach up to 60%.

### Shear at the Interface Calculated from Difference of Normal Forces

Since the method given by Eurocode 2 does not reflect real stress redistribution in the cross-section, alternative formula for the calculation of the shear stress was proposed. Average shear stress at the interface  $v_{Edi}$  is calculated between two neighboring sections as:

$$v_{Edi} = dN_c / b_i \cdot dx. \quad (2)$$

$dN_c$  is the difference of the resultant of normal stresses integrated on one of sectional components (prefabricated part or composite slab) in two neighboring sections of beam element,  $dx$  is the distance between two neighboring sections, and  $b_i$  is the width of the interface, see Fig. 4.

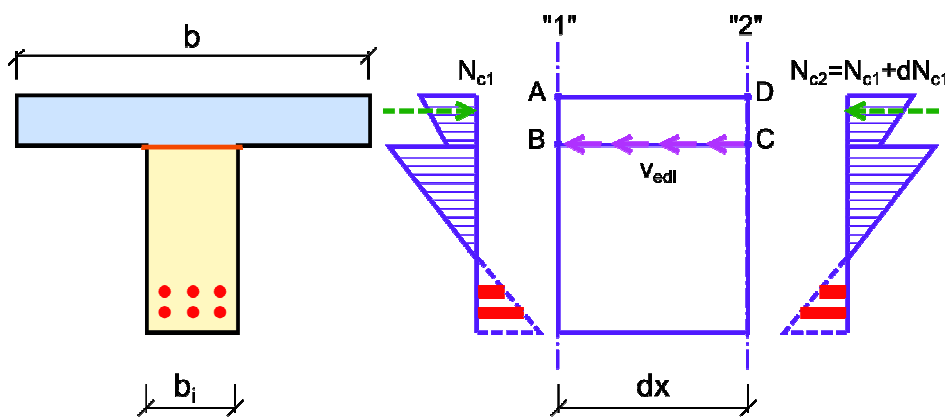

Fig. 4 Calculation of Shear Stress from Difference of Normal Forces

The numerical precision of shear stress calculation depends on the value of the distance  $dx$ . Large value of  $dx$  would decrease calculated average shear stress. Using lowest value of  $dx$  enables us to reach peak shear stress, but numerical instability could appear due to

sensitivity of small differences of normal forces to errors in the numerical calculation of (large) internal forces. Therefore sensitivity study was done to identify the value of  $dx$  most suitable for most common beam examples. Based on the study the decision was taken to use relative value of  $dx = 0.1 h$ . The advantage of the method is that it does reflect stress redistribution in the cross-section caused by consecutive construction, and differential creep and shrinkage of concrete of both composite parts of cross-section.

### Comparison of Methods by Eurocode 2 and from Difference of Normal Forces

Since the discontinuities in the distribution of normal stresses are symptomatic for composite concrete sections, see Fig. 2 and Fig. 3, the question arises as to what error is introduced in the calculation of shear stress  $v_{Edi}$  by using formula (1). To illuminate this issue a study was performed, in which various distributions of normal stress were introduced to the composite cross-section. Stress distributions were induced by altering the age  $t_{ref}$  of first component of cross-section reached at the time of casting of composite (second) component, see Fig. 5. To simplify the modeling, the redistribution was caused by creep and shrinkage only. After 100 years such external load was applied, so that desired distributions of normal stress were reached and shear stress  $v_{Edi}$  was calculated.

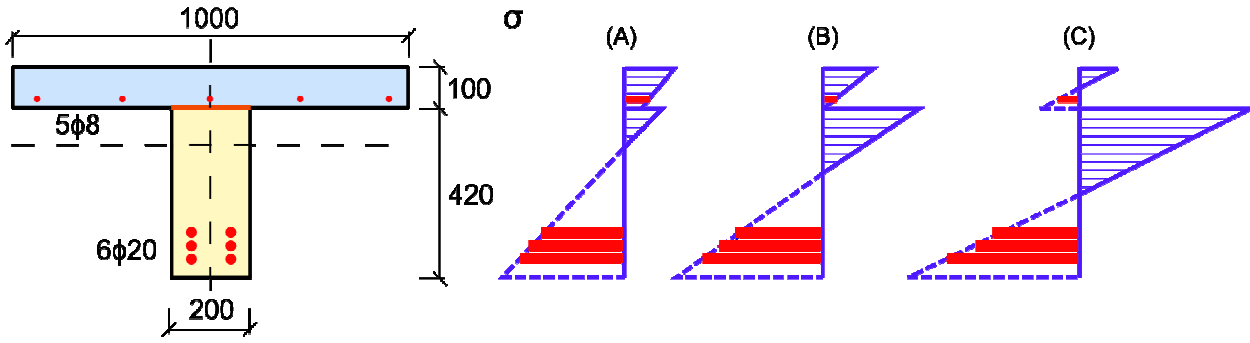

Fig. 5 Cross-Section and Stress Distributions Considered in the Study

The results of the study are shown in Fig. 6 for three different distributions of normal stress A, B, and C. The shear stress  $v_{Edi}$  was determined using:

- formula (1) with  $\beta$  factor calculated as the ratio of the longitudinal forces,
- formula (1) with  $\beta$  factor considered by conservative value of 1.0 where necessary,
- formula (2).

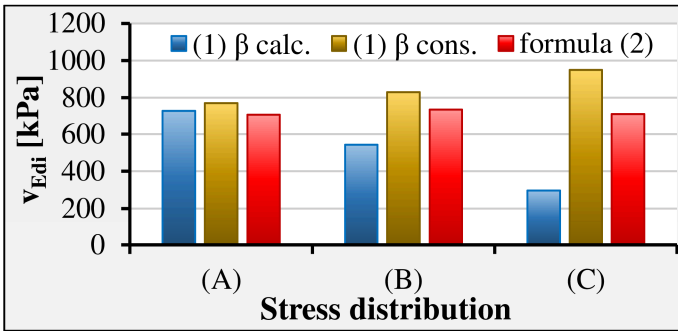

Fig. 6 Comparison of Results Obtained by Formula (1) and (2)

As the method of shear calculation from difference of normal forces according to formula (2) is not limited by assumptions related to normal stress distribution, we consider this method as most appropriate. Therefore we may conclude that EC2 method with  $\beta$  factor calculated underestimates real shear stress in most cases with almost 60% error in the case of stress distribution C. On the other hand, conservative application of EC2 formula

may overestimate realistic shear stress, by 35% in the case of stress distribution C.

To indicate the relevance of the facts mentioned above, two examples of real-life building structures were analyzed.

### Composite Concrete Bridge Analysis

One span concrete composite bridge was analyzed for the effects of dead and superimposed dead loads, construction stages, and moving loads (EN 1991-2). The structure is composed of 12 prefabricated pretensioned beams (C50/60) with composite concrete slab (C30/37), see Fig. 7. The width of the bridge is 12.7 m, characteristic distance of the beams is 1.077 m, the length of beams is 15.8 m.

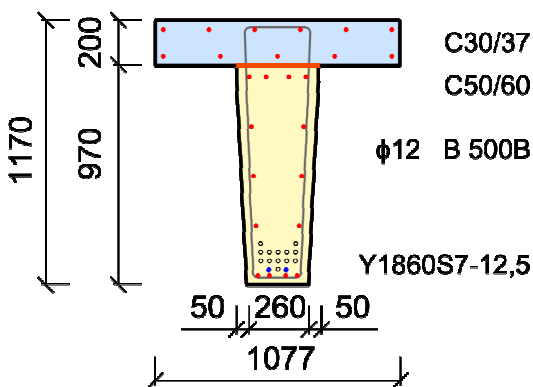

Fig. 7 Cross-Section of Concrete Composite Bridge Beam

Equivalent portion of the load resisted by one beam was determined using 3D FEM model. Consecutively time-dependent analysis was performed using beam model. Following construction stages were modeled: transfer of prestressing, storage yard, casting of composite slab (at the age of prefabricated beams 60 days), final supports, introduction of superimposed dead load, service stages, and the end of design working life (100 years). To obtain single set of results caused by dead loads, partial load factors were considered equal 1.0.

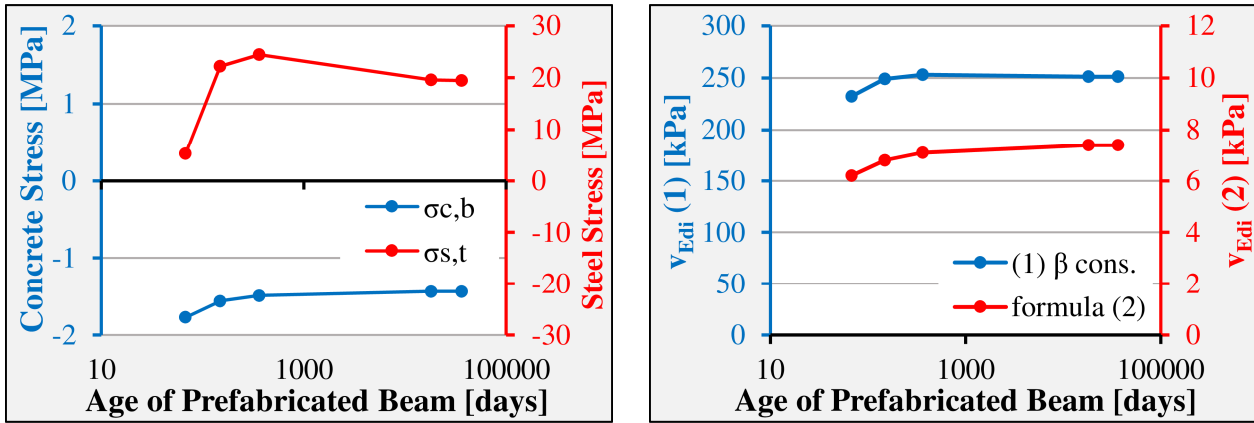

Fig. 8 Normal and Shear Stress Redistribution in Time

Normal and shear stresses were evaluated in the section at distance  $d = 1.1\text{ m}$  from support. First of the findings is that normal stress distribution in this section was never such that  $\beta$  factor could be calculated as the ratio of the longitudinal forces. An example of such normal stress distribution is displayed in Fig. 9. Therefore conservative value of 1.0 was applied in all cases. Second outcome is significant redistribution of both normal and shear stresses caused by dead loads in time, see Fig. 8. In the case of the application of formula (1) the change of  $v_{Edi}$  is caused by the change of lever arm. It can also be observed that shear stresses calculated by formula (1) are significantly higher than stresses calculated by formula (2), which is in accordance with findings above. Similar results were obtained assuming the casting of composite slab at the age of prefabricated beams 20 years (the case of reconstruction) with normal stress redistribution even higher.

Table 1 Total Design Value of Shear Stress  $v_{Edi}$

$V_z$ [kN]	$v_{Edi}(t_{\infty})$ [kPa]		Error
	(1) $\beta$ cons.	formula (2)	
405	1086	1027	6%
308	929	475	96%

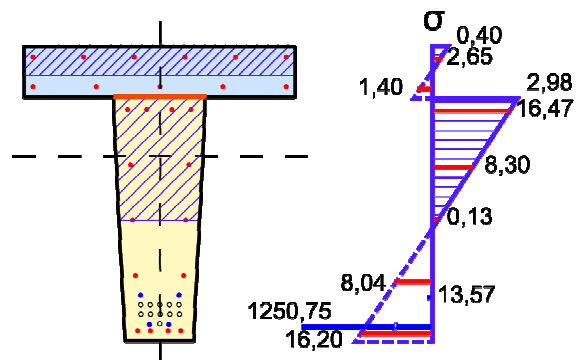

Fig. 9 Normal Stress Distribution for the Combination inducing  $V_z = 308\text{kN}$

In order to document total value of shear stress  $v_{Edi}$ , moving loads were applied at the end of service (100 years). Both Eurocode 2 approach and formula (2) were used to evaluate shear stress for all load combinations. Results of two of them are shown in the Table 1. The difference in the results obtained by both methods is small (6%) in the case of critical shear force  $V_z = 405\text{ kN}$ . This is because construction joint lies within unbroken compression zone. The situation is much different in the case of shear force  $V_z = 308\text{ kN}$ . It is not critical from the point of view of the value of shear stress  $v_{Edi}$ , but there is significant difference between both methods (96%), because separate compression and tension zones appear in both parts of cross-section, see Fig. 9.

### Composite Concrete Floor Beam

Composite concrete floor consist of prefabricated pretensioned beams (C50/60) with composite concrete slab (C20/25), see Fig. 10. The beam span is 6.4 m, dead load  $1.5\text{ kN/m}^2$ , partition walls  $0.8\text{ kN/m}^2$ , and variable load  $1.5\text{ kN/m}^2$ . The beam was analyzed for following construction stages: transfer of prestressing, storage yard, casting of composite slab (at the age of prefabricated beams

28 days), final supports, introduction of superimposed dead load, service stages, and the end of design working life (50 years). Temporary supports at casting of composite slab are assumed in 1/3 and 2/3 of the span. Partial load factors were considered equal 1.0.

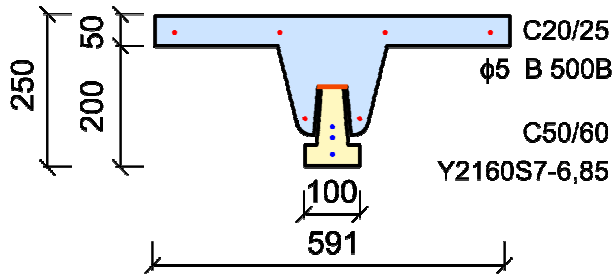

Fig. 10 Cross-Section of Composite Concrete Floor Beam

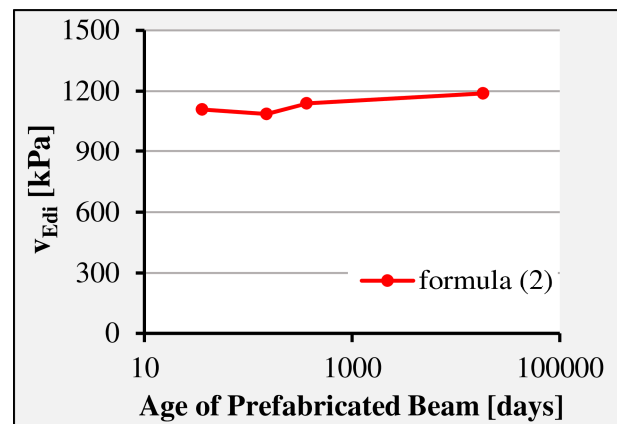

Fig. 11 Shear Stress Redistribution in Time

Normal and shear stresses were evaluated in the section at distance  $d = 0.3 m$  from support. Shear stresses redistribution is shown in Fig. 11. Formula (1) cannot be used for the calculation in this case because the distribution of normal stresses decreases lever arm to very small values, and therefore calculated shear stress would reach unlimited values. Similarly as in composite bridge project above,  $\beta$  factor would have to be taken by conservative value of 1.0.

The value of shear stress  $v_{Edi}$  is above the design shear resistance  $v_{Rdi}$  in this case. One of the reasons is that only more efficient part of construction joint (with indented surface) was considered as effective. Two smooth planes of construction joint on the sides of prefabricated beam were disregarded. Therefore an additional reinforcement of the joint would be necessary.

## Conclusion

The methods for the calculation of shear stresses in construction joint were reviewed in the paper. It was found that Eurocode 2 method is not suitable for shear stress calculation in the case of normal stress distributions, which are typical for concrete composite cross-section. The method does not reflect stress redistribution in the cross-section caused by consecutive construction, and differential creep and shrinkage of concrete of both composite parts of cross-section. By applying Eurocode 2 method we may either underestimate shear stresses (calculated  $\beta$  factor) or we obtain uneconomic design (conservative  $\beta$  factor). Calculation method alternative to Eurocode 2 method is proposed and tested. It is recommended to calculate the shear stress from difference of normal forces acting on sectional components in two neighboring sections of the element. Numerical studies were performed based on real-life examples of composite beams.

## References

- [1] EN 1992-1-1. Eurocode 2: Design of Concrete Structures – Part 1-1: General rules and rules for buildings, European Committee for Standardization, (2011).
- [2] J. Navrátil, IDEA StatiCa Prestressing, User guide, IDEA RS s.r.o., U Vodarny 2a, 616 00 BRNO, [www.idea-rs.com](http://www.idea-rs.com)