

Project: Atlanta Industrial
Project no: 2021-1254-Z
Author: Dave the Engineer

Project data

Project name	Atlanta Industrial
Project number	2021-1254-Z
Author	Dave the Engineer
Description	Steel hall with a complex crane structure
Date	5/30/2021
Design code	AISC 360-16

Material

Steel	A36
-------	-----

Project: Atlanta Industrial
Project no: 2021-1254-Z
Author: Dave the Engineer

Project item Beam-to-column connection 25 - steel hall

Design

Name Beam-to-column connection 25 - steel hall
Description Atlanta Industrial project
Analysis Stress, strain/ simplified loading
Design code AISC - LRFD 2016

Beams and columns

Name	Cross-section	β - Direction [°]	γ - Pitch [°]	α - Rotation [°]	Offset ex [in]	Offset ey [in]	Offset ez [in]	Forces in
C	1 - HP(Imp)8X36	0.0	90.0	0.0	0.000	0.000	0.000	Node
B	2 - S(Imp)10X25.4	0.0	-10.0	0.0	0.000	0.000	0.000	Node

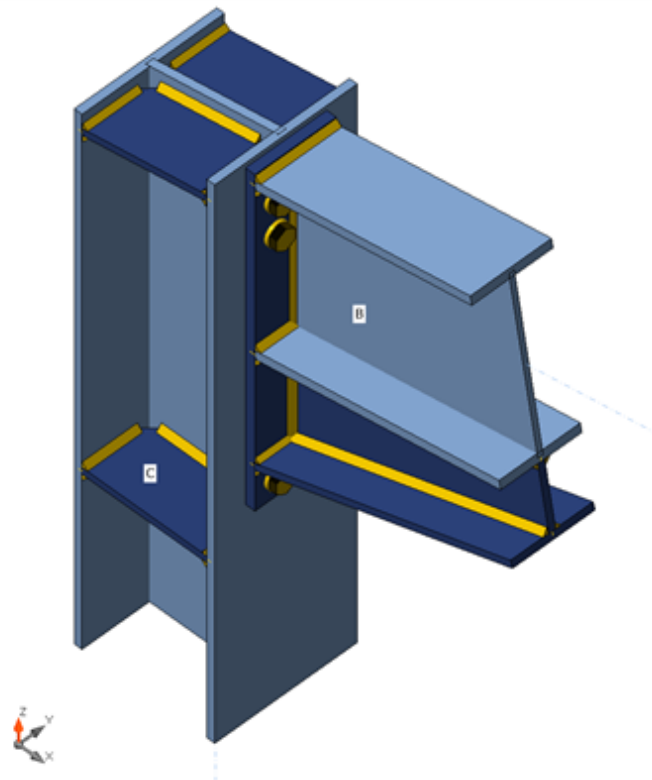

Project: Atlanta Industrial
Project no: 2021-1254-Z
Author: Dave the Engineer

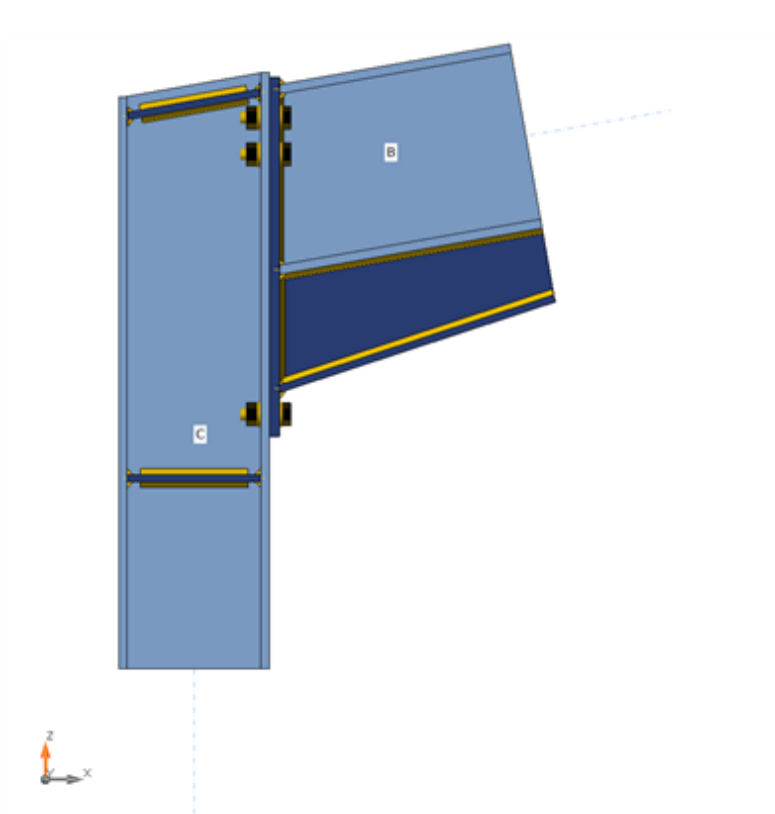
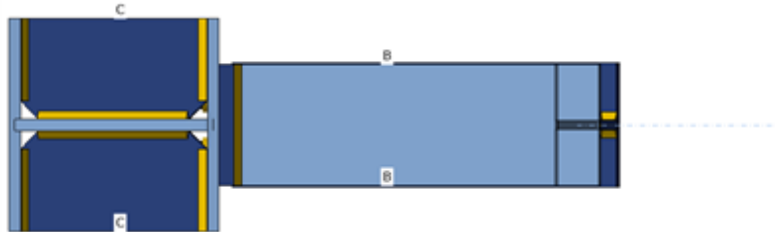

Project: Atlanta Industrial
Project no: 2021-1254-Z
Author: Dave the Engineer

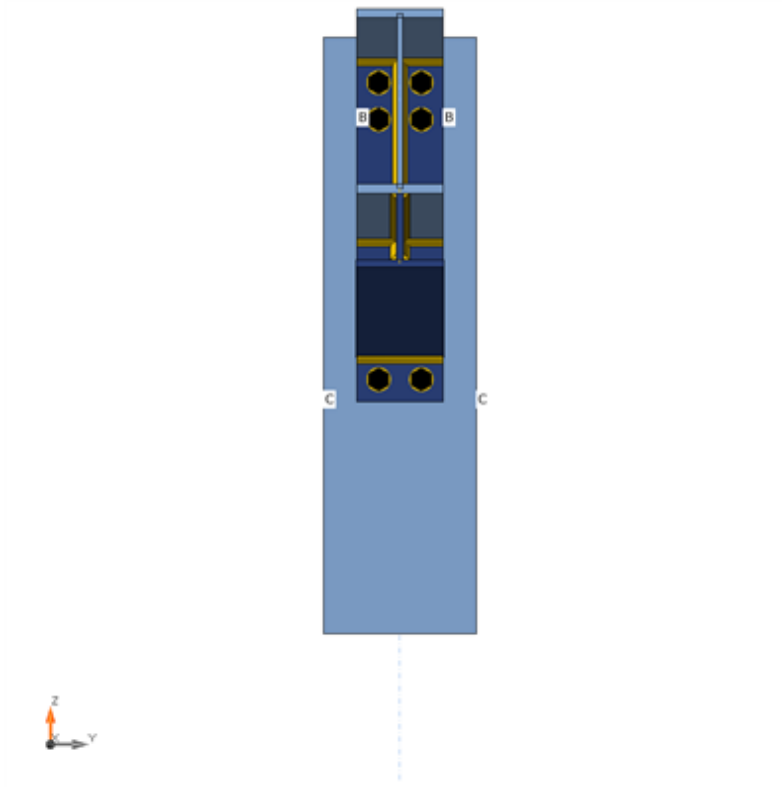

Cross-sections

Name	Material
1 - HP(Imp)8X36	A36
2 - S(Imp)10X25.4	A36

Cross-sections

Name	Material	Drawing
1 - HP(Imp)8X36	A36	
2 - S(Imp)10X25.4	A36	

Bolts

Name	Bolt assembly	Diameter [in]	fu [ksi]	Gross area [in ²]
5/8 A325	5/8 A325	0.625	120.0	0.307

Load effects (equilibrium not required)

Name	Member	N [kip]	Vy [kip]	Vz [kip]	Mx [kip.in]	My [kip.in]	Mz [kip.in]
LE1	B	0.000	0.000	-30.233	0.00	686.57	0.00

Check

Summary

Name	Value	Check status
Analysis	100.0%	OK
Plates	0.3 < 5.0%	OK
Bolts	77.4 < 100%	OK
Welds	78.4 < 100%	OK
Buckling	Not calculated	

Project: Atlanta Industrial
 Project no: 2021-1254-Z
 Author: Dave the Engineer

Plates

Name	F _y [ksi]	Thickness [in]	Loads	σ _{Ed} [ksi]	ε _{pl} [%]	σ _C Ed [ksi]	Check status
C-bfl 1	36.0	7/16	LE1	24.7	0.0	0.0	OK
C-tfl 1	36.0	7/16	LE1	32.5	0.3	7.0	OK
C-w 1	36.0	7/16	LE1	30.4	0.0	0.0	OK
B-bfl 1	36.0	1/2	LE1	25.0	0.0	0.0	OK
B-tfl 1	36.0	1/2	LE1	19.1	0.0	0.0	OK
B-w 1	36.0	5/16	LE1	26.3	0.0	0.0	OK
STIFF1a	36.0	3/8	LE1	29.5	0.0	0.0	OK
STIFF1b	36.0	3/8	LE1	29.5	0.0	0.0	OK
EP1	36.0	9/16	LE1	32.4	0.1	7.0	OK
WID1a	36.0	3/8	LE1	27.8	0.0	0.0	OK
WID1b	36.0	3/8	LE1	25.6	0.0	0.0	OK
STIFF2a	36.0	3/8	LE1	6.3	0.0	0.0	OK
STIFF2b	36.0	3/8	LE1	6.3	0.0	0.0	OK

Design data

Material	f _y [ksi]	ε _{lim} [%]
A36	36.0	5.0

Symbol explanation

ε _{pl}	Plastic strain
σ _C Ed	Contact stress
σ _{Ed}	Eq. stress
f _y	Yield strength
ε _{lim}	Limit of plastic strain

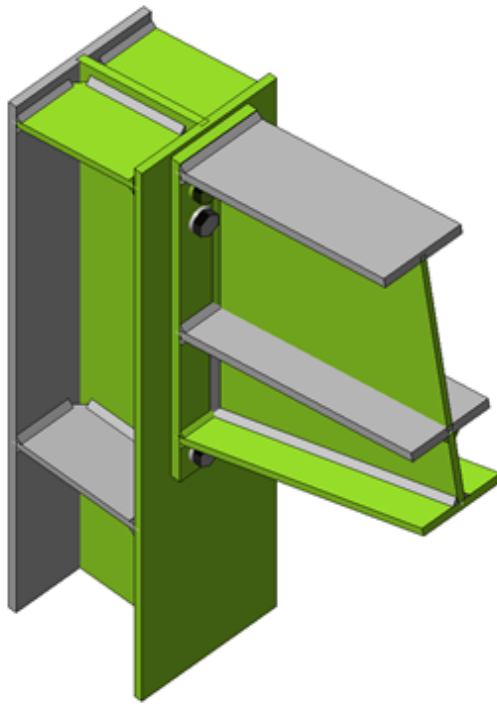

Overall check, LE1

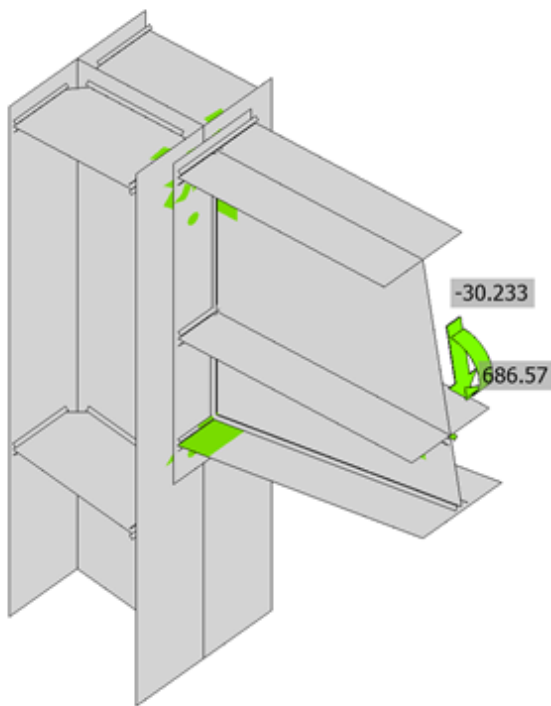

Strain check, LE1

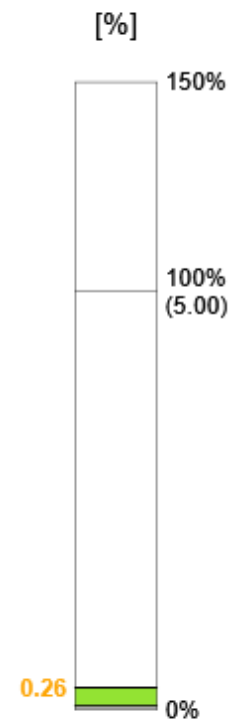

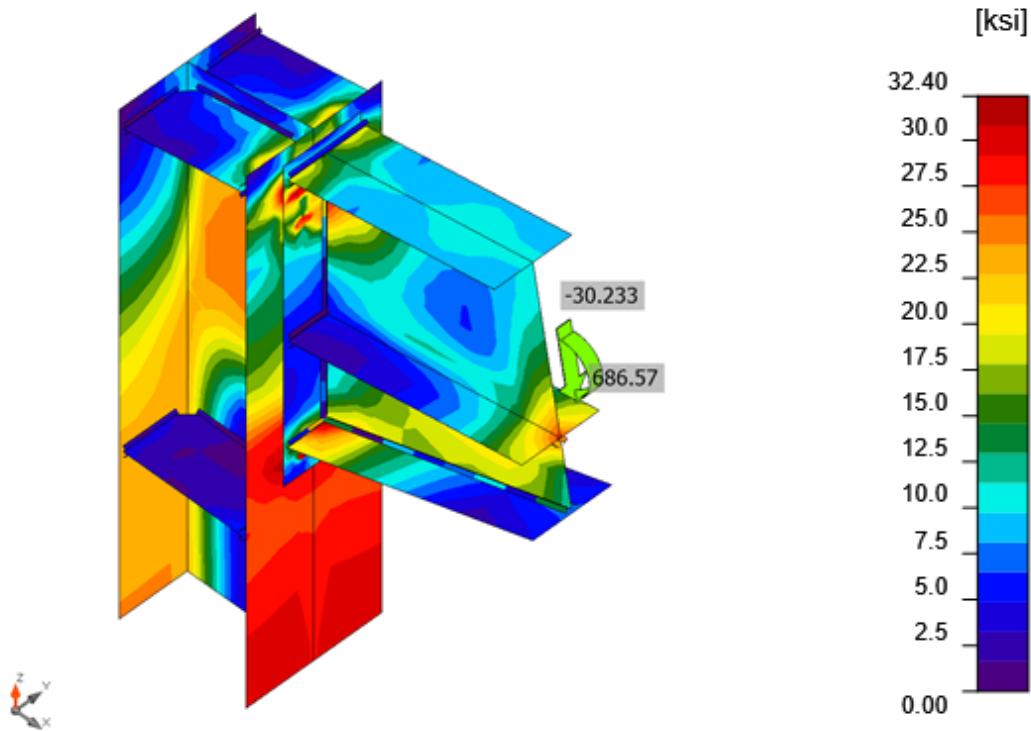

Equivalent stress, LE1

Bolts

Shape	Item	Grade	Loads	F_t [kip]	V [kip]	$\phi R_{n,bearing}$ [kip]	U_{t_t} [%]	U_{t_s} [%]	$U_{t_{ts}}$ [%]	Status
	B1	5/8 A325 - 1	LE1	16.005	3.716	29.045	77.4	29.9	-	OK
	B2	5/8 A325 - 1	LE1	16.004	3.716	29.045	77.3	29.9	-	OK
	B3	5/8 A325 - 1	LE1	9.784	3.990	29.045	47.3	32.1	48.3	OK
	B4	5/8 A325 - 1	LE1	9.785	3.989	29.045	47.3	32.1	48.3	OK
	B5	5/8 A325 - 1	LE1	0.132	7.186	29.045	0.6	57.9	-	OK
	B6	5/8 A325 - 1	LE1	0.143	7.187	29.045	0.7	57.9	-	OK

Design data

Grade	$\phi R_{n,tension}$ [kip]	$\phi R_{n, shear}$ [kip]
5/8 A325 - 1	20.691	12.415

Symbol explanation

- F_t Tension force
- V Resultant of shear forces V_y, V_z in bolt
- $\phi R_{n,bearing}$ Bolt bearing resistance
- U_{t_t} Utilization in tension
- U_{t_s} Utilization in shear
- $U_{t_{ts}}$ Utilization in tension and shear
- $\phi R_{n,tension}$ Bolt tension resistance AISC 360-16 J3.6
- $\phi R_{n, shear}$ Bolt shear resistance AISC 360-16 – J3.8

Project: Atlanta Industrial
Project no: 2021-1254-Z
Author: Dave the Engineer

Detailed result for B1

Tension resistance check (AISC 360-16: J3-1)

$$\phi R_n = \phi \cdot F_{nt} \cdot A_b = 20.691 \text{ kip} \geq F_t = 16.005 \text{ kip}$$

Where:

$$F_{nt} = 89.9 \text{ ksi} \quad \text{– nominal tensile stress from AISC 360-16 Table J3.2}$$

$$A_b = 0.307 \text{ in}^2 \quad \text{– gross bolt cross-sectional area}$$

$$\phi = 0.75 \quad \text{– capacity factor}$$

Shear resistance check (AISC 360-16: J3-1)

$$\phi R_n = \phi \cdot F_{nv} \cdot A_b = 12.415 \text{ kip} \geq V = 3.716 \text{ kip}$$

Where:

$$F_{nv} = 54.0 \text{ ksi} \quad \text{– nominal shear stress from AISC 360-16 Table J3.2}$$

$$A_b = 0.307 \text{ in}^2 \quad \text{– gross bolt cross-sectional area}$$

$$\phi = 0.75 \quad \text{– capacity factor}$$

Bearing resistance check (AISC 360-16: J3-6)

$$R_n = 1.20 \cdot l_c \cdot t \cdot F_u \leq 2.40 \cdot d \cdot t \cdot F_u$$

$$\phi R_n = 29.045 \text{ kip} \geq V = 3.716 \text{ kip}$$

Where:

$$l_c = 1.281 \text{ in} \quad \text{– clear distance, in the direction of the force, between the edge of the hole and the edge of the adjacent hole or edge of the material}$$

$$t = 0.445 \text{ in} \quad \text{– thickness of the plate}$$

$$d = 0.625 \text{ in} \quad \text{– diameter of a bolt}$$

$$F_u = 58.0 \text{ ksi} \quad \text{– tensile strength of the connected material}$$

$$\phi = 0.75 \quad \text{– resistance factor for bearing at bolt holes}$$

Interaction of tension and shear check (AISC 360-16: J3-2)

The required stress, in either shear or tension, is less than or equal to 30% of the corresponding available stress and the effects of combined stresses need not to be investigated.

Detailed result for B2

Tension resistance check (AISC 360-16: J3-1)

$$\phi R_n = \phi \cdot F_{nt} \cdot A_b = 20.691 \text{ kip} \geq F_t = 16.004 \text{ kip}$$

Where:

$$F_{nt} = 89.9 \text{ ksi} \quad \text{– nominal tensile stress from AISC 360-16 Table J3.2}$$

$$A_b = 0.307 \text{ in}^2 \quad \text{– gross bolt cross-sectional area}$$

$$\phi = 0.75 \quad \text{– capacity factor}$$

Project: Atlanta Industrial
Project no: 2021-1254-Z
Author: Dave the Engineer

Shear resistance check (AISC 360-16: J3-1)

$$\phi R_n = \phi \cdot F_{nv} \cdot A_b = 12.415 \text{ kip} \geq V = 3.716 \text{ kip}$$

Where:

$F_{nv} = 54.0 \text{ ksi}$ – nominal shear stress from AISC 360-16 Table J3.2

$A_b = 0.307 \text{ in}^2$ – gross bolt cross-sectional area

$\phi = 0.75$ – capacity factor

Bearing resistance check (AISC 360-16: J3-6)

$$R_n = 1.20 \cdot l_c \cdot t \cdot F_u \leq 2.40 \cdot d \cdot t \cdot F_u$$

$$\phi R_n = 29.045 \text{ kip} \geq V = 3.716 \text{ kip}$$

Where:

$l_c = 1.281 \text{ in}$ – clear distance, in the direction of the force, between the edge of the hole and the edge of the adjacent hole or edge of the material

$t = 0.445 \text{ in}$ – thickness of the plate

$d = 0.625 \text{ in}$ – diameter of a bolt

$F_u = 58.0 \text{ ksi}$ – tensile strength of the connected material

$\phi = 0.75$ – resistance factor for bearing at bolt holes

Interaction of tension and shear check (AISC 360-16: J3-2)

The required stress, in either shear or tension, is less than or equal to 30% of the corresponding available stress and the effects of combined stresses need not to be investigated.

Detailed result for B3

Tension resistance check (AISC 360-16: J3-1)

$$\phi R_n = \phi \cdot F_{nt} \cdot A_b = 20.691 \text{ kip} \geq F_t = 9.784 \text{ kip}$$

Where:

$F_{nt} = 89.9 \text{ ksi}$ – nominal tensile stress from AISC 360-16 Table J3.2

$A_b = 0.307 \text{ in}^2$ – gross bolt cross-sectional area

$\phi = 0.75$ – capacity factor

Shear resistance check (AISC 360-16: J3-1)

$$\phi R_n = \phi \cdot F_{nv} \cdot A_b = 12.415 \text{ kip} \geq V = 3.990 \text{ kip}$$

Where:

$F_{nv} = 54.0 \text{ ksi}$ – nominal shear stress from AISC 360-16 Table J3.2

$A_b = 0.307 \text{ in}^2$ – gross bolt cross-sectional area

$\phi = 0.75$ – capacity factor

Bearing resistance check (AISC 360-16: J3-6)

$$R_n = 1.20 \cdot l_c \cdot t \cdot F_u \leq 2.40 \cdot d \cdot t \cdot F_u$$

$$\phi R_n = 29.045 \text{ kip} \geq V = 3.990 \text{ kip}$$

Where:

$l_c = 1.281 \text{ in}$ – clear distance, in the direction of the force, between the edge of the hole and the edge of the adjacent hole or edge of the material

$t = 0.445 \text{ in}$ – thickness of the plate

$d = 0.625 \text{ in}$ – diameter of a bolt

$F_u = 58.0 \text{ ksi}$ – tensile strength of the connected material

$\phi = 0.75$ – resistance factor for bearing at bolt holes

Interaction of tension and shear check (AISC 360-16: J3-3b)

$$\phi R_n = \phi \cdot F'_{nt} \cdot A_b = 20.249 \text{ kip} \geq F_t = 9.784 \text{ kip}$$

Where:

$F'_{nt} = 88.0 \text{ ksi}$ – nominal tensile stress modified to include the effects of shear stress:

- $F'_{nt} = 1.3 \cdot F_{nt} - \frac{f_{rv} \cdot F_{nt}}{\phi \cdot F_{nv}} \leq F_{nt}$, where:
 - $F_{nt} = 89.9 \text{ ksi}$ – nominal tensile stress from AISC 360-16 Table J3.2
 - $F_{nv} = 54.0 \text{ ksi}$ – nominal shear stress from AISC 360-16 Table J3.2
 - $f_{rv} = 13.0 \text{ ksi}$ – required shear stress using LRFD or ASD load combinations. The available shear stress of the fastener shall be equal or exceed the required shear stress.
 - $\phi = 0.75$ – resistance factor for tension and shear combination

$A_b = 0.307 \text{ in}^2$ – gross bolt cross-sectional area

Detailed result for B4

Tension resistance check (AISC 360-16: J3-1)

$$\phi R_n = \phi \cdot F_{nt} \cdot A_b = 20.691 \text{ kip} \geq F_t = 9.785 \text{ kip}$$

Where:

$F_{nt} = 89.9 \text{ ksi}$ – nominal tensile stress from AISC 360-16 Table J3.2

$A_b = 0.307 \text{ in}^2$ – gross bolt cross-sectional area

$\phi = 0.75$ – capacity factor

Shear resistance check (AISC 360-16: J3-1)

$$\phi R_n = \phi \cdot F_{nv} \cdot A_b = 12.415 \text{ kip} \geq V = 3.989 \text{ kip}$$

Where:

$F_{nv} = 54.0 \text{ ksi}$ – nominal shear stress from AISC 360-16 Table J3.2

$A_b = 0.307 \text{ in}^2$ – gross bolt cross-sectional area

$\phi = 0.75$ – capacity factor

Bearing resistance check (AISC 360-16: J3-6)

$$R_n = 1.20 \cdot l_c \cdot t \cdot F_u \leq 2.40 \cdot d \cdot t \cdot F_u$$

$$\phi R_n = 29.045 \text{ kip} \geq V = 3.989 \text{ kip}$$

Where:

$l_c = 1.281 \text{ in}$ – clear distance, in the direction of the force, between the edge of the hole and the edge of the adjacent hole or edge of the material

$t = 0.445 \text{ in}$ – thickness of the plate

$d = 0.625 \text{ in}$ – diameter of a bolt

$F_u = 58.0 \text{ ksi}$ – tensile strength of the connected material

$\phi = 0.75$ – resistance factor for bearing at bolt holes

Interaction of tension and shear check (AISC 360-16: J3-3b)

$$\phi R_n = \phi \cdot F'_{nt} \cdot A_b = 20.249 \text{ kip} \geq F_t = 9.785 \text{ kip}$$

Where:

$F'_{nt} = 88.0 \text{ ksi}$ – nominal tensile stress modified to include the effects of shear stress:

- $F'_{nt} = 1.3 \cdot F_{nt} - \frac{f_{rv} \cdot F_{nt}}{\phi \cdot F_{nv}} \leq F_{nt}$, where:
 - $F_{nt} = 89.9 \text{ ksi}$ – nominal tensile stress from AISC 360-16 Table J3.2
 - $F_{nv} = 54.0 \text{ ksi}$ – nominal shear stress from AISC 360-16 Table J3.2
 - $f_{rv} = 13.0 \text{ ksi}$ – required shear stress using LRFD or ASD load combinations. The available shear stress of the fastener shall be equal or exceed the required shear stress.
 - $\phi = 0.75$ – resistance factor for tension and shear combination

$A_b = 0.307 \text{ in}^2$ – gross bolt cross-sectional area

Detailed result for B5

Tension resistance check (AISC 360-16: J3-1)

$$\phi R_n = \phi \cdot F_{nt} \cdot A_b = 20.691 \text{ kip} \geq F_t = 0.132 \text{ kip}$$

Where:

$F_{nt} = 89.9 \text{ ksi}$ – nominal tensile stress from AISC 360-16 Table J3.2

$A_b = 0.307 \text{ in}^2$ – gross bolt cross-sectional area

$\phi = 0.75$ – capacity factor

Shear resistance check (AISC 360-16: J3-1)

$$\phi R_n = \phi \cdot F_{nv} \cdot A_b = 12.415 \text{ kip} \geq V = 7.186 \text{ kip}$$

Where:

$F_{nv} = 54.0 \text{ ksi}$ – nominal shear stress from AISC 360-16 Table J3.2

$A_b = 0.307 \text{ in}^2$ – gross bolt cross-sectional area

$\phi = 0.75$ – capacity factor

Bearing resistance check (AISC 360-16: J3-6)

$$R_n = 1.20 \cdot l_c \cdot t \cdot F_u \leq 2.40 \cdot d \cdot t \cdot F_u$$

$$\phi R_n = 29.045 \text{ kip} \geq V = 7.186 \text{ kip}$$

Where:

$l_c = 13.207 \text{ in}$ – clear distance, in the direction of the force, between the edge of the hole and the edge of the adjacent hole or edge of the material

$t = 0.445 \text{ in}$ – thickness of the plate

$d = 0.625 \text{ in}$ – diameter of a bolt

$F_u = 58.0 \text{ ksi}$ – tensile strength of the connected material

$\phi = 0.75$ – resistance factor for bearing at bolt holes

Interaction of tension and shear check (AISC 360-16: J3-2)

The required stress, in either shear or tension, is less than or equal to 30% of the corresponding available stress and the effects of combined stresses need not to be investigated.

Detailed result for B6

Tension resistance check (AISC 360-16: J3-1)

$$\phi R_n = \phi \cdot F_{nt} \cdot A_b = 20.691 \text{ kip} \geq F_t = 0.143 \text{ kip}$$

Where:

$F_{nt} = 89.9 \text{ ksi}$ – nominal tensile stress from AISC 360-16 Table J3.2

$A_b = 0.307 \text{ in}^2$ – gross bolt cross-sectional area

$\phi = 0.75$ – capacity factor

Shear resistance check (AISC 360-16: J3-1)

$$\phi R_n = \phi \cdot F_{nv} \cdot A_b = 12.415 \text{ kip} \geq V = 7.187 \text{ kip}$$

Where:

$F_{nv} = 54.0 \text{ ksi}$ – nominal shear stress from AISC 360-16 Table J3.2

$A_b = 0.307 \text{ in}^2$ – gross bolt cross-sectional area

$\phi = 0.75$ – capacity factor

Bearing resistance check (AISC 360-16: J3-6)

$$R_n = 1.20 \cdot l_c \cdot t \cdot F_u \leq 2.40 \cdot d \cdot t \cdot F_u$$

$$\phi R_n = 29.045 \text{ kip} \geq V = 7.187 \text{ kip}$$

Where:

$l_c = 13.207 \text{ in}$ – clear distance, in the direction of the force, between the edge of the hole and the edge of the adjacent hole or edge of the material

$t = 0.445 \text{ in}$ – thickness of the plate

$d = 0.625 \text{ in}$ – diameter of a bolt

$F_u = 58.0 \text{ ksi}$ – tensile strength of the connected material

$\phi = 0.75$ – resistance factor for bearing at bolt holes

Project: Atlanta Industrial
Project no: 2021-1254-Z
Author: Dave the Engineer

Interaction of tension and shear check (AISC 360-16: J3-2)

The required stress, in either shear or tension, is less than or equal to 30% of the corresponding available stress and the effects of combined stresses need not to be investigated.

Project: Atlanta Industrial
Project no: 2021-1254-Z
Author: Dave the Engineer

Welds

Item	Edge	Xu	T _h [in]	L _s [in]	L [in]	L _c [in]	Loads	F _n [kip]	φR _n [kip]	Ut [%]	Status
C-bfl 1	STIFF1a	E70xx	▲1/4▲	▲5/16▲	3.148	0.787	LE1	0.833	7.741	10.8	OK
		E70xx	▲1/4▲	▲5/16▲	3.148	0.787	LE1	0.929	5.604	16.6	OK
C-w 1	STIFF1a	E70xx	▲1/4▲	▲5/16▲	5.777	0.963	LE1	1.477	9.958	14.8	OK
		E70xx	▲1/4▲	▲5/16▲	5.777	0.963	LE1	1.243	8.442	14.7	OK
C-tfl 1	STIFF1a	E70xx	▲1/4▲	▲5/16▲	3.148	0.787	LE1	5.075	8.218	61.8	OK
		E70xx	▲1/4▲	▲5/16▲	3.140	0.785	LE1	0.717	7.946	9.0	OK
C-bfl 1	STIFF1b	E70xx	▲1/4▲	▲5/16▲	3.148	0.787	LE1	0.928	5.604	16.6	OK
		E70xx	▲1/4▲	▲5/16▲	3.148	0.787	LE1	0.833	7.741	10.8	OK
C-w 1	STIFF1b	E70xx	▲1/4▲	▲5/16▲	5.777	0.963	LE1	1.242	8.443	14.7	OK
		E70xx	▲1/4▲	▲5/16▲	5.777	0.963	LE1	1.477	9.959	14.8	OK
C-tfl 1	STIFF1b	E70xx	▲1/4▲	▲5/16▲	3.140	0.785	LE1	0.710	7.934	8.9	OK
		E70xx	▲1/4▲	▲5/16▲	3.148	0.787	LE1	5.066	8.218	61.6	OK
EP1	B-bfl 1	E70xx	▲1/4▲	▲3/8▲	4.630	1.157	LE1	0.561	13.576	4.1	OK
		E70xx	▲1/4▲	▲3/8▲	4.630	1.157	LE1	1.112	13.389	8.3	OK
EP1	B-tfl 1	E70xx	▲1/4▲	▲3/8▲	4.630	1.157	LE1	2.275	11.702	19.4	OK
		E70xx	▲1/4▲	▲3/8▲	4.638	1.159	LE1	3.773	12.978	29.1	OK
EP1	B-w 1	E70xx	▲3/16▲	▲1/4▲	9.623	1.203	LE1	7.121	9.485	75.1	OK
		E70xx	▲3/16▲	▲1/4▲	9.623	1.203	LE1	7.121	9.485	75.1	OK
EP1	WID1a	E70xx	▲1/4▲	▲5/16▲	5.886	1.177	LE1	2.315	11.037	21.0	OK
		E70xx	▲1/4▲	▲5/16▲	5.886	1.177	LE1	2.292	11.042	20.8	OK
B-bfl 1	WID1a	E70xx	▲1/4▲	▲5/16▲	14.234	1.294	LE1	9.126	11.644	78.4	OK
		E70xx	▲1/4▲	▲5/16▲	14.234	1.294	LE1	9.125	11.643	78.4	OK
WID1b	WID1a	E70xx	▲1/4▲	▲5/16▲	15.423	1.928	LE1	6.391	14.949	42.8	OK
		E70xx	▲1/4▲	▲5/16▲	15.423	1.928	LE1	6.394	14.818	43.2	OK
EP1	WID1b	E70xx	▲1/4▲	▲5/16▲	4.630	1.157	LE1	8.753	11.655	75.1	OK
		E70xx	▲1/4▲	▲5/16▲	4.630	1.157	LE1	8.513	12.057	70.6	OK
C-bfl 1	STIFF2a	E70xx	▲1/4▲	▲5/16▲	3.148	0.787	LE1	0.494	5.982	8.3	OK
		E70xx	▲1/4▲	▲5/16▲	3.148	0.787	LE1	0.571	7.024	8.1	OK
C-w 1	STIFF2a	E70xx	▲1/4▲	▲5/16▲	5.736	0.956	LE1	0.943	9.938	9.5	OK
		E70xx	▲1/4▲	▲5/16▲	5.736	0.956	LE1	0.951	9.816	9.7	OK
C-tfl 1	STIFF2a	E70xx	▲1/4▲	▲5/16▲	3.148	0.787	LE1	0.736	6.191	11.9	OK
		E70xx	▲1/4▲	▲5/16▲	3.148	0.787	LE1	0.790	6.215	12.7	OK
C-bfl 1	STIFF2b	E70xx	▲1/4▲	▲5/16▲	3.148	0.787	LE1	0.571	7.021	8.1	OK
		E70xx	▲1/4▲	▲5/16▲	3.148	0.787	LE1	0.494	5.979	8.3	OK
C-w 1	STIFF2b	E70xx	▲1/4▲	▲5/16▲	5.736	0.956	LE1	0.953	9.816	9.7	OK
		E70xx	▲1/4▲	▲5/16▲	5.736	0.956	LE1	0.944	9.939	9.5	OK
C-tfl 1	STIFF2b	E70xx	▲1/4▲	▲5/16▲	3.148	0.787	LE1	0.783	6.240	12.6	OK
		E70xx	▲1/4▲	▲5/16▲	3.148	0.787	LE1	0.729	6.194	11.8	OK

Symbol explanation

T_h	Throat thickness of weld
L_s	Leg size of weld
L	Length of weld
L_c	Length of weld critical element
F_n	Force in weld critical element
ϕR_n	Weld resistance AISC 360-16 J2.4
U_t	Utilization

Detailed result for C-bfl 1 / STIFF1a - 1

Weld resistance check (AISC 360-16: J2-4)

$$\phi R_n = \phi \cdot F_{nw} \cdot A_{we} = 7.741 \text{ kip} \geq F_n = 0.833 \text{ kip}$$

Where:

$F_{nw} = 58.9 \text{ ksi}$ – nominal stress of weld material:

- $F_{nw} = 0.6 \cdot F_{EXX} \cdot (1 + 0.5 \cdot \sin^{1.5}\theta)$, where:
 - $F_{EXX} = 70.0 \text{ ksi}$ – electrode classification number, i.e. minimum specified tensile strength
 - $\theta = 59.9^\circ$ – angle of loading measured from the weld longitudinal axis

$A_{we} = 0.175 \text{ in}^2$ – effective area of weld critical element

$\phi = 0.75$ – resistance factor for welded connections

Detailed result for C-bfl 1 / STIFF1a - 2

Weld resistance check (AISC 360-16: J2-4)

$$\phi R_n = \phi \cdot F_{nw} \cdot A_{we} = 5.604 \text{ kip} \geq F_n = 0.929 \text{ kip}$$

Where:

$F_{nw} = 42.6 \text{ ksi}$ – nominal stress of weld material:

- $F_{nw} = 0.6 \cdot F_{EXX} \cdot (1 + 0.5 \cdot \sin^{1.5}\theta)$, where:
 - $F_{EXX} = 70.0 \text{ ksi}$ – electrode classification number, i.e. minimum specified tensile strength
 - $\theta = 5.6^\circ$ – angle of loading measured from the weld longitudinal axis

$A_{we} = 0.175 \text{ in}^2$ – effective area of weld critical element

$\phi = 0.75$ – resistance factor for welded connections

Detailed result for C-w 1 / STIFF1a - 1

Weld resistance check (AISC 360-16: J2-4)

$$\phi R_n = \phi \cdot F_{nw} \cdot A_{we} = 9.958 \text{ kip} \geq F_n = 1.477 \text{ kip}$$

Where:

$F_{nw} = 61.9 \text{ ksi}$ – nominal stress of weld material:

- $F_{nw} = 0.6 \cdot F_{EXX} \cdot (1 + 0.5 \cdot \sin^{1.5}\theta)$, where:
 - $F_{EXX} = 70.0 \text{ ksi}$ – electrode classification number, i.e. minimum specified tensile strength
 - $\theta = 74.9^\circ$ – angle of loading measured from the weld longitudinal axis

$A_{we} = 0.214 \text{ in}^2$ – effective area of weld critical element

$\phi = 0.75$ – resistance factor for welded connections

Detailed result for C-w 1 / STIFF1a - 2

Weld resistance check (AISC 360-16: J2-4)

$$\phi R_n = \phi \cdot F_{nw} \cdot A_{we} = 8.442 \text{ kip} \geq F_n = 1.243 \text{ kip}$$

Where:

$F_{nw} = 52.5 \text{ ksi}$ – nominal stress of weld material:

- $F_{nw} = 0.6 \cdot F_{EXX} \cdot (1 + 0.5 \cdot \sin^{1.5}\theta)$, where:
 - $F_{EXX} = 70.0 \text{ ksi}$ – electrode classification number, i.e. minimum specified tensile strength
 - $\theta = 39.0^\circ$ – angle of loading measured from the weld longitudinal axis

$A_{we} = 0.214 \text{ in}^2$ – effective area of weld critical element

$\phi = 0.75$ – resistance factor for welded connections

Detailed result for C-tfl 1 / STIFF1a - 1

Weld resistance check (AISC 360-16: J2-4)

$$\phi R_n = \phi \cdot F_{nw} \cdot A_{we} = 8.218 \text{ kip} \geq F_n = 5.075 \text{ kip}$$

Where:

$F_{nw} = 62.5 \text{ ksi}$ – nominal stress of weld material:

- $F_{nw} = 0.6 \cdot F_{EXX} \cdot (1 + 0.5 \cdot \sin^{1.5}\theta)$, where:
 - $F_{EXX} = 70.0 \text{ ksi}$ – electrode classification number, i.e. minimum specified tensile strength
 - $\theta = 80.0^\circ$ – angle of loading measured from the weld longitudinal axis

$A_{we} = 0.175 \text{ in}^2$ – effective area of weld critical element

$\phi = 0.75$ – resistance factor for welded connections

Detailed result for C-tfl 1 / STIFF1a - 2

Weld resistance check (AISC 360-16: J2-4)

$$\phi R_n = \phi \cdot F_{nw} \cdot A_{we} = 7.946 \text{ kip} \geq F_n = 0.717 \text{ kip}$$

Where:

$F_{nw} = 60.6 \text{ ksi}$ – nominal stress of weld material:

- $F_{nw} = 0.6 \cdot F_{EXX} \cdot (1 + 0.5 \cdot \sin^{1.5}\theta)$, where:
 - $F_{EXX} = 70.0 \text{ ksi}$ – electrode classification number, i.e. minimum specified tensile strength
 - $\theta = 67.3^\circ$ – angle of loading measured from the weld longitudinal axis

$A_{we} = 0.175 \text{ in}^2$ – effective area of weld critical element

$\phi = 0.75$ – resistance factor for welded connections

Detailed result for C-bfl 1 / STIFF1b - 1

Weld resistance check (AISC 360-16: J2-4)

$$\phi R_n = \phi \cdot F_{nw} \cdot A_{we} = 5.604 \text{ kip} \geq F_n = 0.928 \text{ kip}$$

Where:

$F_{nw} = 42.6 \text{ ksi}$ – nominal stress of weld material:

- $F_{nw} = 0.6 \cdot F_{EXX} \cdot (1 + 0.5 \cdot \sin^{1.5}\theta)$, where:
 - $F_{EXX} = 70.0 \text{ ksi}$ – electrode classification number, i.e. minimum specified tensile strength
 - $\theta = 5.6^\circ$ – angle of loading measured from the weld longitudinal axis

$A_{we} = 0.175 \text{ in}^2$ – effective area of weld critical element

$\phi = 0.75$ – resistance factor for welded connections

Detailed result for C-bfl 1 / STIFF1b - 2

Weld resistance check (AISC 360-16: J2-4)

$$\phi R_n = \phi \cdot F_{nw} \cdot A_{we} = 7.741 \text{ kip} \geq F_n = 0.833 \text{ kip}$$

Where:

$F_{nw} = 58.9 \text{ ksi}$ – nominal stress of weld material:

- $F_{nw} = 0.6 \cdot F_{EXX} \cdot (1 + 0.5 \cdot \sin^{1.5}\theta)$, where:
 - $F_{EXX} = 70.0 \text{ ksi}$ – electrode classification number, i.e. minimum specified tensile strength
 - $\theta = 59.9^\circ$ – angle of loading measured from the weld longitudinal axis

$A_{we} = 0.175 \text{ in}^2$ – effective area of weld critical element

$\phi = 0.75$ – resistance factor for welded connections

Detailed result for C-w 1 / STIFF1b - 1

Weld resistance check (AISC 360-16: J2-4)

$$\phi R_n = \phi \cdot F_{nw} \cdot A_{we} = 8.443 \text{ kip} \geq F_n = 1.242 \text{ kip}$$

Where:

$F_{nw} = 52.5 \text{ ksi}$ – nominal stress of weld material:

- $F_{nw} = 0.6 \cdot F_{EXX} \cdot (1 + 0.5 \cdot \sin^{1.5}\theta)$, where:
 - $F_{EXX} = 70.0 \text{ ksi}$ – electrode classification number, i.e. minimum specified tensile strength
 - $\theta = 39.0^\circ$ – angle of loading measured from the weld longitudinal axis

$A_{we} = 0.214 \text{ in}^2$ – effective area of weld critical element

$\phi = 0.75$ – resistance factor for welded connections

Detailed result for C-w 1 / STIFF1b - 2

Weld resistance check (AISC 360-16: J2-4)

$$\phi R_n = \phi \cdot F_{nw} \cdot A_{we} = 9.959 \text{ kip} \geq F_n = 1.477 \text{ kip}$$

Where:

$F_{nw} = 61.9 \text{ ksi}$ – nominal stress of weld material:

- $F_{nw} = 0.6 \cdot F_{EXX} \cdot (1 + 0.5 \cdot \sin^{1.5}\theta)$, where:
 - $F_{EXX} = 70.0 \text{ ksi}$ – electrode classification number, i.e. minimum specified tensile strength
 - $\theta = 74.9^\circ$ – angle of loading measured from the weld longitudinal axis

$A_{we} = 0.214 \text{ in}^2$ – effective area of weld critical element

$\phi = 0.75$ – resistance factor for welded connections

Detailed result for C-tfl 1 / STIFF1b - 1

Weld resistance check (AISC 360-16: J2-4)

$$\phi R_n = \phi \cdot F_{nw} \cdot A_{we} = 7.934 \text{ kip} \geq F_n = 0.710 \text{ kip}$$

Where:

$F_{nw} = 60.5 \text{ ksi}$ – nominal stress of weld material:

- $F_{nw} = 0.6 \cdot F_{EXX} \cdot (1 + 0.5 \cdot \sin^{1.5}\theta)$, where:
 - $F_{EXX} = 70.0 \text{ ksi}$ – electrode classification number, i.e. minimum specified tensile strength
 - $\theta = 66.8^\circ$ – angle of loading measured from the weld longitudinal axis

$A_{we} = 0.175 \text{ in}^2$ – effective area of weld critical element

$\phi = 0.75$ – resistance factor for welded connections

Detailed result for C-tfl 1 / STIFF1b - 2

Weld resistance check (AISC 360-16: J2-4)

$$\phi R_n = \phi \cdot F_{nw} \cdot A_{we} = 8.218 \text{ kip} \geq F_n = 5.066 \text{ kip}$$

Where:

$F_{nw} = 62.5 \text{ ksi}$ – nominal stress of weld material:

- $F_{nw} = 0.6 \cdot F_{EXX} \cdot (1 + 0.5 \cdot \sin^{1.5}\theta)$, where:
 - $F_{EXX} = 70.0 \text{ ksi}$ – electrode classification number, i.e. minimum specified tensile strength
 - $\theta = 80.0^\circ$ – angle of loading measured from the weld longitudinal axis

$A_{we} = 0.175 \text{ in}^2$ – effective area of weld critical element

$\phi = 0.75$ – resistance factor for welded connections

Detailed result for EP1 / B-bfl 1 - 1

Weld resistance check (AISC 360-16: J2-4)

$$\phi R_n = \phi \cdot F_{nw} \cdot A_{we} = 13.576 \text{ kip} \geq F_n = 0.561 \text{ kip}$$

Where:

$F_{nw} = 62.4 \text{ ksi}$ – nominal stress of weld material:

- $F_{nw} = 0.6 \cdot F_{EXX} \cdot (1 + 0.5 \cdot \sin^{1.5}\theta)$, where:
 - $F_{EXX} = 70.0 \text{ ksi}$ – electrode classification number, i.e. minimum specified tensile strength
 - $\theta = 78.9^\circ$ – angle of loading measured from the weld longitudinal axis

$A_{we} = 0.290 \text{ in}^2$ – effective area of weld critical element

$\phi = 0.75$ – resistance factor for welded connections

Detailed result for EP1 / B-bfl 1 - 2

Weld resistance check (AISC 360-16: J2-4)

$$\phi R_n = \phi \cdot F_{nw} \cdot A_{we} = 13.389 \text{ kip} \geq F_n = 1.112 \text{ kip}$$

Where:

$F_{nw} = 61.6 \text{ ksi}$ – nominal stress of weld material:

- $F_{nw} = 0.6 \cdot F_{EXX} \cdot (1 + 0.5 \cdot \sin^{1.5}\theta)$, where:
 - $F_{EXX} = 70.0 \text{ ksi}$ – electrode classification number, i.e. minimum specified tensile strength
 - $\theta = 72.5^\circ$ – angle of loading measured from the weld longitudinal axis

$A_{we} = 0.290 \text{ in}^2$ – effective area of weld critical element

$\phi = 0.75$ – resistance factor for welded connections

Detailed result for EP1 / B-tfl 1 - 1

Weld resistance check (AISC 360-16: J2-4)

$$\phi R_n = \phi \cdot F_{nw} \cdot A_{we} = 11.702 \text{ kip} \geq F_n = 2.275 \text{ kip}$$

Where:

$F_{nw} = 53.8 \text{ ksi}$ – nominal stress of weld material:

- $F_{nw} = 0.6 \cdot F_{EXX} \cdot (1 + 0.5 \cdot \sin^{1.5}\theta)$, where:
 - $F_{EXX} = 70.0 \text{ ksi}$ – electrode classification number, i.e. minimum specified tensile strength
 - $\theta = 42.9^\circ$ – angle of loading measured from the weld longitudinal axis

$A_{we} = 0.290 \text{ in}^2$ – effective area of weld critical element

$\phi = 0.75$ – resistance factor for welded connections

Detailed result for EP1 / B-tfl 1 - 2

Weld resistance check (AISC 360-16: J2-4)

$$\phi R_n = \phi \cdot F_{nw} \cdot A_{we} = 12.978 \text{ kip} \geq F_n = 3.773 \text{ kip}$$

Where:

$F_{nw} = 59.6 \text{ ksi}$ – nominal stress of weld material:

- $F_{nw} = 0.6 \cdot F_{EXX} \cdot (1 + 0.5 \cdot \sin^{1.5}\theta)$, where:
 - $F_{EXX} = 70.0 \text{ ksi}$ – electrode classification number, i.e. minimum specified tensile strength
 - $\theta = 62.6^\circ$ – angle of loading measured from the weld longitudinal axis

$A_{we} = 0.290 \text{ in}^2$ – effective area of weld critical element

$\phi = 0.75$ – resistance factor for welded connections

Detailed result for EP1 / B-w 1 - 1

Weld resistance check (AISC 360-16: J2-4)

$$\phi R_n = \phi \cdot F_{nw} \cdot A_{we} = 9.485 \text{ kip} \geq F_n = 7.121 \text{ kip}$$

Where:

$F_{nw} = 62.9 \text{ ksi}$ – nominal stress of weld material:

- $F_{nw} = 0.6 \cdot F_{EXX} \cdot (1 + 0.5 \cdot \sin^{1.5}\theta)$, where:
 - $F_{EXX} = 70.0 \text{ ksi}$ – electrode classification number, i.e. minimum specified tensile strength
 - $\theta = 86.5^\circ$ – angle of loading measured from the weld longitudinal axis

$A_{we} = 0.201 \text{ in}^2$ – effective area of weld critical element

$\phi = 0.75$ – resistance factor for welded connections

Detailed result for EP1 / B-w 1 - 2

Weld resistance check (AISC 360-16: J2-4)

$$\phi R_n = \phi \cdot F_{nw} \cdot A_{we} = 9.485 \text{ kip} \geq F_n = 7.121 \text{ kip}$$

Where:

$F_{nw} = 62.9 \text{ ksi}$ – nominal stress of weld material:

- $F_{nw} = 0.6 \cdot F_{EXX} \cdot (1 + 0.5 \cdot \sin^{1.5}\theta)$, where:
 - $F_{EXX} = 70.0 \text{ ksi}$ – electrode classification number, i.e. minimum specified tensile strength
 - $\theta = 86.5^\circ$ – angle of loading measured from the weld longitudinal axis

$A_{we} = 0.201 \text{ in}^2$ – effective area of weld critical element

$\phi = 0.75$ – resistance factor for welded connections

Detailed result for EP1 / WID1a - 1

Weld resistance check (AISC 360-16: J2-4)

$$\phi R_n = \phi \cdot F_{nw} \cdot A_{we} = 11.037 \text{ kip} \geq F_n = 2.315 \text{ kip}$$

Where:

$F_{nw} = 56.1 \text{ ksi}$ – nominal stress of weld material:

- $F_{nw} = 0.6 \cdot F_{EXX} \cdot (1 + 0.5 \cdot \sin^{1.5}\theta)$, where:
 - $F_{EXX} = 70.0 \text{ ksi}$ – electrode classification number, i.e. minimum specified tensile strength
 - $\theta = 50.2^\circ$ – angle of loading measured from the weld longitudinal axis

$A_{we} = 0.262 \text{ in}^2$ – effective area of weld critical element

$\phi = 0.75$ – resistance factor for welded connections

Detailed result for EP1 / WID1a - 2

Weld resistance check (AISC 360-16: J2-4)

$$\phi R_n = \phi \cdot F_{nw} \cdot A_{we} = 11.042 \text{ kip} \geq F_n = 2.292 \text{ kip}$$

Where:

$F_{nw} = 56.2 \text{ ksi}$ – nominal stress of weld material:

- $F_{nw} = 0.6 \cdot F_{EXX} \cdot (1 + 0.5 \cdot \sin^{1.5}\theta)$, where:
 - $F_{EXX} = 70.0 \text{ ksi}$ – electrode classification number, i.e. minimum specified tensile strength
 - $\theta = 50.3^\circ$ – angle of loading measured from the weld longitudinal axis

$A_{we} = 0.262 \text{ in}^2$ – effective area of weld critical element

$\phi = 0.75$ – resistance factor for welded connections

Detailed result for B-bfl 1 / WID1a - 1

Weld resistance check (AISC 360-16: J2-4)

$$\phi R_n = \phi \cdot F_{nw} \cdot A_{we} = 11.644 \text{ kip} \geq F_n = 9.126 \text{ kip}$$

Where:

$F_{nw} = 53.9 \text{ ksi}$ – nominal stress of weld material:

- $F_{nw} = 0.6 \cdot F_{EXX} \cdot (1 + 0.5 \cdot \sin^{1.5}\theta)$, where:
 - $F_{EXX} = 70.0 \text{ ksi}$ – electrode classification number, i.e. minimum specified tensile strength
 - $\theta = 43.1^\circ$ – angle of loading measured from the weld longitudinal axis

$A_{we} = 0.288 \text{ in}^2$ – effective area of weld critical element

$\phi = 0.75$ – resistance factor for welded connections

Detailed result for B-bfl 1 / WID1a - 2

Weld resistance check (AISC 360-16: J2-4)

$$\phi R_n = \phi \cdot F_{nw} \cdot A_{we} = 11.643 \text{ kip} \geq F_n = 9.125 \text{ kip}$$

Where:

$F_{nw} = 53.9 \text{ ksi}$ – nominal stress of weld material:

- $F_{nw} = 0.6 \cdot F_{EXX} \cdot (1 + 0.5 \cdot \sin^{1.5}\theta)$, where:
 - $F_{EXX} = 70.0 \text{ ksi}$ – electrode classification number, i.e. minimum specified tensile strength
 - $\theta = 43.1^\circ$ – angle of loading measured from the weld longitudinal axis

$A_{we} = 0.288 \text{ in}^2$ – effective area of weld critical element

$\phi = 0.75$ – resistance factor for welded connections

Detailed result for WID1b / WID1a - 1

Weld resistance check (AISC 360-16: J2-4)

$$\phi R_n = \phi \cdot F_{nw} \cdot A_{we} = 14.949 \text{ kip} \geq F_n = 6.391 \text{ kip}$$

Where:

$F_{nw} = 46.4 \text{ ksi}$ – nominal stress of weld material:

- $F_{nw} = 0.6 \cdot F_{EXX} \cdot (1 + 0.5 \cdot \sin^{1.5}\theta)$, where:
 - $F_{EXX} = 70.0 \text{ ksi}$ – electrode classification number, i.e. minimum specified tensile strength
 - $\theta = 20.7^\circ$ – angle of loading measured from the weld longitudinal axis

$A_{we} = 0.429 \text{ in}^2$ – effective area of weld critical element

$\phi = 0.75$ – resistance factor for welded connections

Detailed result for WID1b / WID1a - 2

Weld resistance check (AISC 360-16: J2-4)

$$\phi R_n = \phi \cdot F_{nw} \cdot A_{we} = 14.818 \text{ kip} \geq F_n = 6.394 \text{ kip}$$

Where:

$F_{nw} = 46.0 \text{ ksi}$ – nominal stress of weld material:

- $F_{nw} = 0.6 \cdot F_{EXX} \cdot (1 + 0.5 \cdot \sin^{1.5}\theta)$, where:
 - $F_{EXX} = 70.0 \text{ ksi}$ – electrode classification number, i.e. minimum specified tensile strength
 - $\theta = 19.4^\circ$ – angle of loading measured from the weld longitudinal axis

$A_{we} = 0.429 \text{ in}^2$ – effective area of weld critical element

$\phi = 0.75$ – resistance factor for welded connections

Detailed result for EP1 / WID1b - 1

Weld resistance check (AISC 360-16: J2-4)

$$\phi R_n = \phi \cdot F_{nw} \cdot A_{we} = 11.655 \text{ kip} \geq F_n = 8.753 \text{ kip}$$

Where:

$F_{nw} = 60.3 \text{ ksi}$ – nominal stress of weld material:

- $F_{nw} = 0.6 \cdot F_{EXX} \cdot (1 + 0.5 \cdot \sin^{1.5}\theta)$, where:
 - $F_{EXX} = 70.0 \text{ ksi}$ – electrode classification number, i.e. minimum specified tensile strength
 - $\theta = 65.8^\circ$ – angle of loading measured from the weld longitudinal axis

$A_{we} = 0.258 \text{ in}^2$ – effective area of weld critical element

$\phi = 0.75$ – resistance factor for welded connections

Detailed result for EP1 / WID1b - 2

Weld resistance check (AISC 360-16: J2-4)

$$\phi R_n = \phi \cdot F_{nw} \cdot A_{we} = 12.057 \text{ kip} \geq F_n = 8.513 \text{ kip}$$

Where:

$F_{nw} = 62.4 \text{ ksi}$ – nominal stress of weld material:

- $F_{nw} = 0.6 \cdot F_{EXX} \cdot (1 + 0.5 \cdot \sin^{1.5}\theta)$, where:
 - $F_{EXX} = 70.0 \text{ ksi}$ – electrode classification number, i.e. minimum specified tensile strength
 - $\theta = 78.4^\circ$ – angle of loading measured from the weld longitudinal axis

$A_{we} = 0.258 \text{ in}^2$ – effective area of weld critical element

$\phi = 0.75$ – resistance factor for welded connections

Detailed result for C-bfl 1 / STIFF2a - 1

Weld resistance check (AISC 360-16: J2-4)

$$\phi R_n = \phi \cdot F_{nw} \cdot A_{we} = 5.982 \text{ kip} \geq F_n = 0.494 \text{ kip}$$

Where:

$F_{nw} = 45.5 \text{ ksi}$ – nominal stress of weld material:

- $F_{nw} = 0.6 \cdot F_{EXX} \cdot (1 + 0.5 \cdot \sin^{1.5}\theta)$, where:
 - $F_{EXX} = 70.0 \text{ ksi}$ – electrode classification number, i.e. minimum specified tensile strength
 - $\theta = 17.7^\circ$ – angle of loading measured from the weld longitudinal axis

$A_{we} = 0.175 \text{ in}^2$ – effective area of weld critical element

$\phi = 0.75$ – resistance factor for welded connections

Detailed result for C-bfl 1 / STIFF2a - 2

Weld resistance check (AISC 360-16: J2-4)

$$\phi R_n = \phi \cdot F_{nw} \cdot A_{we} = 7.024 \text{ kip} \geq F_n = 0.571 \text{ kip}$$

Where:

$F_{nw} = 53.4 \text{ ksi}$ – nominal stress of weld material:

- $F_{nw} = 0.6 \cdot F_{EXX} \cdot (1 + 0.5 \cdot \sin^{1.5}\theta)$, where:
 - $F_{EXX} = 70.0 \text{ ksi}$ – electrode classification number, i.e. minimum specified tensile strength
 - $\theta = 41.8^\circ$ – angle of loading measured from the weld longitudinal axis

$A_{we} = 0.175 \text{ in}^2$ – effective area of weld critical element

$\phi = 0.75$ – resistance factor for welded connections

Detailed result for C-w 1 / STIFF2a - 1

Weld resistance check (AISC 360-16: J2-4)

$$\phi R_n = \phi \cdot F_{nw} \cdot A_{we} = 9.938 \text{ kip} \geq F_n = 0.943 \text{ kip}$$

Where:

$F_{nw} = 62.2 \text{ ksi}$ – nominal stress of weld material:

- $F_{nw} = 0.6 \cdot F_{EXX} \cdot (1 + 0.5 \cdot \sin^{1.5}\theta)$, where:
 - $F_{EXX} = 70.0 \text{ ksi}$ – electrode classification number, i.e. minimum specified tensile strength
 - $\theta = 77.3^\circ$ – angle of loading measured from the weld longitudinal axis

$A_{we} = 0.213 \text{ in}^2$ – effective area of weld critical element

$\phi = 0.75$ – resistance factor for welded connections

Detailed result for C-w 1 / STIFF2a - 2

Weld resistance check (AISC 360-16: J2-4)

$$\phi R_n = \phi \cdot F_{nw} \cdot A_{we} = 9.816 \text{ kip} \geq F_n = 0.951 \text{ kip}$$

Where:

$F_{nw} = 61.5 \text{ ksi}$ – nominal stress of weld material:

- $F_{nw} = 0.6 \cdot F_{EXX} \cdot (1 + 0.5 \cdot \sin^{1.5}\theta)$, where:
 - $F_{EXX} = 70.0 \text{ ksi}$ – electrode classification number, i.e. minimum specified tensile strength
 - $\theta = 71.9^\circ$ – angle of loading measured from the weld longitudinal axis

$A_{we} = 0.213 \text{ in}^2$ – effective area of weld critical element

$\phi = 0.75$ – resistance factor for welded connections

Detailed result for C-tfl 1 / STIFF2a - 1

Weld resistance check (AISC 360-16: J2-4)

$$\phi R_n = \phi \cdot F_{nw} \cdot A_{we} = 6.191 \text{ kip} \geq F_n = 0.736 \text{ kip}$$

Where:

$F_{nw} = 47.1 \text{ ksi}$ – nominal stress of weld material:

- $F_{nw} = 0.6 \cdot F_{EXX} \cdot (1 + 0.5 \cdot \sin^{1.5}\theta)$, where:
 - $F_{EXX} = 70.0 \text{ ksi}$ – electrode classification number, i.e. minimum specified tensile strength
 - $\theta = 22.9^\circ$ – angle of loading measured from the weld longitudinal axis

$A_{we} = 0.175 \text{ in}^2$ – effective area of weld critical element

$\phi = 0.75$ – resistance factor for welded connections

Detailed result for C-tfl 1 / STIFF2a - 2

Weld resistance check (AISC 360-16: J2-4)

$$\phi R_n = \phi \cdot F_{nw} \cdot A_{we} = 6.215 \text{ kip} \geq F_n = 0.790 \text{ kip}$$

Where:

$F_{nw} = 47.3 \text{ ksi}$ – nominal stress of weld material:

- $F_{nw} = 0.6 \cdot F_{EXX} \cdot (1 + 0.5 \cdot \sin^{1.5}\theta)$, where:
 - $F_{EXX} = 70.0 \text{ ksi}$ – electrode classification number, i.e. minimum specified tensile strength
 - $\theta = 23.5^\circ$ – angle of loading measured from the weld longitudinal axis

$A_{we} = 0.175 \text{ in}^2$ – effective area of weld critical element

$\phi = 0.75$ – resistance factor for welded connections

Detailed result for C-bfl 1 / STIFF2b - 1

Weld resistance check (AISC 360-16: J2-4)

$$\phi R_n = \phi \cdot F_{nw} \cdot A_{we} = 7.021 \text{ kip} \geq F_n = 0.571 \text{ kip}$$

Where:

$F_{nw} = 53.4 \text{ ksi}$ – nominal stress of weld material:

- $F_{nw} = 0.6 \cdot F_{EXX} \cdot (1 + 0.5 \cdot \sin^{1.5}\theta)$, where:
 - $F_{EXX} = 70.0 \text{ ksi}$ – electrode classification number, i.e. minimum specified tensile strength
 - $\theta = 41.8^\circ$ – angle of loading measured from the weld longitudinal axis

$A_{we} = 0.175 \text{ in}^2$ – effective area of weld critical element

$\phi = 0.75$ – resistance factor for welded connections

Detailed result for C-bfl 1 / STIFF2b - 2

Weld resistance check (AISC 360-16: J2-4)

$$\phi R_n = \phi \cdot F_{nw} \cdot A_{we} = 5.979 \text{ kip} \geq F_n = 0.494 \text{ kip}$$

Where:

$F_{nw} = 45.5 \text{ ksi}$ – nominal stress of weld material:

- $F_{nw} = 0.6 \cdot F_{EXX} \cdot (1 + 0.5 \cdot \sin^{1.5}\theta)$, where:
 - $F_{EXX} = 70.0 \text{ ksi}$ – electrode classification number, i.e. minimum specified tensile strength
 - $\theta = 17.6^\circ$ – angle of loading measured from the weld longitudinal axis

$A_{we} = 0.175 \text{ in}^2$ – effective area of weld critical element

$\phi = 0.75$ – resistance factor for welded connections

Detailed result for C-w 1 / STIFF2b - 1

Weld resistance check (AISC 360-16: J2-4)

$$\phi R_n = \phi \cdot F_{nw} \cdot A_{we} = 9.816 \text{ kip} \geq F_n = 0.953 \text{ kip}$$

Where:

$F_{nw} = 61.5 \text{ ksi}$ – nominal stress of weld material:

- $F_{nw} = 0.6 \cdot F_{EXX} \cdot (1 + 0.5 \cdot \sin^{1.5}\theta)$, where:
 - $F_{EXX} = 70.0 \text{ ksi}$ – electrode classification number, i.e. minimum specified tensile strength
 - $\theta = 72.0^\circ$ – angle of loading measured from the weld longitudinal axis

$A_{we} = 0.213 \text{ in}^2$ – effective area of weld critical element

$\phi = 0.75$ – resistance factor for welded connections

Detailed result for C-w 1 / STIFF2b - 2

Weld resistance check (AISC 360-16: J2-4)

$$\phi R_n = \phi \cdot F_{nw} \cdot A_{we} = 9.939 \text{ kip} \geq F_n = 0.944 \text{ kip}$$

Where:

$F_{nw} = 62.2 \text{ ksi}$ – nominal stress of weld material:

- $F_{nw} = 0.6 \cdot F_{EXX} \cdot (1 + 0.5 \cdot \sin^{1.5}\theta)$, where:
 - $F_{EXX} = 70.0 \text{ ksi}$ – electrode classification number, i.e. minimum specified tensile strength
 - $\theta = 77.3^\circ$ – angle of loading measured from the weld longitudinal axis

$A_{we} = 0.213 \text{ in}^2$ – effective area of weld critical element

$\phi = 0.75$ – resistance factor for welded connections

Detailed result for C-tfl 1 / STIFF2b - 1

Weld resistance check (AISC 360-16: J2-4)

$$\phi R_n = \phi \cdot F_{nw} \cdot A_{we} = 6.240 \text{ kip} \geq F_n = 0.783 \text{ kip}$$

Where:

$F_{nw} = 47.5 \text{ ksi}$ – nominal stress of weld material:

- $F_{nw} = 0.6 \cdot F_{EXX} \cdot (1 + 0.5 \cdot \sin^{1.5}\theta)$, where:
 - $F_{EXX} = 70.0 \text{ ksi}$ – electrode classification number, i.e. minimum specified tensile strength
 - $\theta = 24.1^\circ$ – angle of loading measured from the weld longitudinal axis

$A_{we} = 0.175 \text{ in}^2$ – effective area of weld critical element

$\phi = 0.75$ – resistance factor for welded connections

Detailed result for C-tfl 1 / STIFF2b - 2

Weld resistance check (AISC 360-16: J2-4)

$$\phi R_n = \phi \cdot F_{nw} \cdot A_{we} = 6.194 \text{ kip} \geq F_n = 0.729 \text{ kip}$$

Where:

$F_{nw} = 47.1 \text{ ksi}$ – nominal stress of weld material:

- $F_{nw} = 0.6 \cdot F_{EXX} \cdot (1 + 0.5 \cdot \sin^{1.5}\theta)$, where:
 - $F_{EXX} = 70.0 \text{ ksi}$ – electrode classification number, i.e. minimum specified tensile strength
 - $\theta = 23.0^\circ$ – angle of loading measured from the weld longitudinal axis

$A_{we} = 0.175 \text{ in}^2$ – effective area of weld critical element

$\phi = 0.75$ – resistance factor for welded connections

Buckling

Buckling analysis was not calculated.

Project: Atlanta Industrial
 Project no: 2021-1254-Z
 Author: Dave the Engineer

Cost estimation

Steel

Steel grade	Total weight [lbm]	Unit cost [US\$/lbm]	Cost [US\$]
A36	33.77	1.13	38.29

Welds

Weld type	Throat thickness [in]	Leg size [in]	Total weight [lbm]	Unit cost [US\$/lbm]	Cost [US\$]
Double fillet	1/4	5/16	2.49	20.41	50.85
Double fillet	1/4	3/8	0.33	20.41	6.75
Double fillet	3/16	1/4	0.15	20.41	3.12

Bolts

Bolt assembly	Total weight [lbm]	Unit cost [US\$/lbm]	Cost [US\$]
5/8 A325	3.46	2.72	9.42

Hole drilling

Bolt assembly cost [US\$]	Percentage of bolt assembly cost [%]	Cost [US\$]
9.42	30.0	2.83





Cost summary

Cost estimation summary	Cost [US\$]
Total estimated cost	111.26

Project: Atlanta Industrial
 Project no: 2021-1254-Z
 Author: Dave the Engineer

Bill of material

Manufacturing operations

Name	Plates [in]	Shape	Nr.	Welds [in]	Length [in]	Bolts	Nr.
STIFF1	P3/8x3.9-7.2 (A36)		2	Double fillet: a = 1/4	24.2		
EP1	P9/16x4.6-19.2 (A36)		1	Double fillet: a = 1/4 Double fillet: a = 3/16	9.3 9.7	5/8 A325	6
WID1	P3/8x8.4-14.7 (A36)		1	Double fillet: a = 1/4	40.2		
	P3/8x4.7-15.5 (A36)		1				
STIFF2	P3/8x3.9-7.1 (A36)		2	Double fillet: a = 1/4	24.1		
CUT2							

Welds

Type	Material	Throat thickness [in]	Leg size [in]	Length [in]
Double fillet	E70xx	1/4	5/16	88.6
Double fillet	E70xx	1/4	3/8	9.3
Double fillet	E70xx	3/16	1/4	9.7

Bolts

Name	Grip length [in]	Count
5/8 A325	0.984	6

Project: Atlanta Industrial
Project no: 2021-1254-Z
Author: Dave the Engineer

Drawing

STIFF1

P3/8x7.182-3.852 (A36)

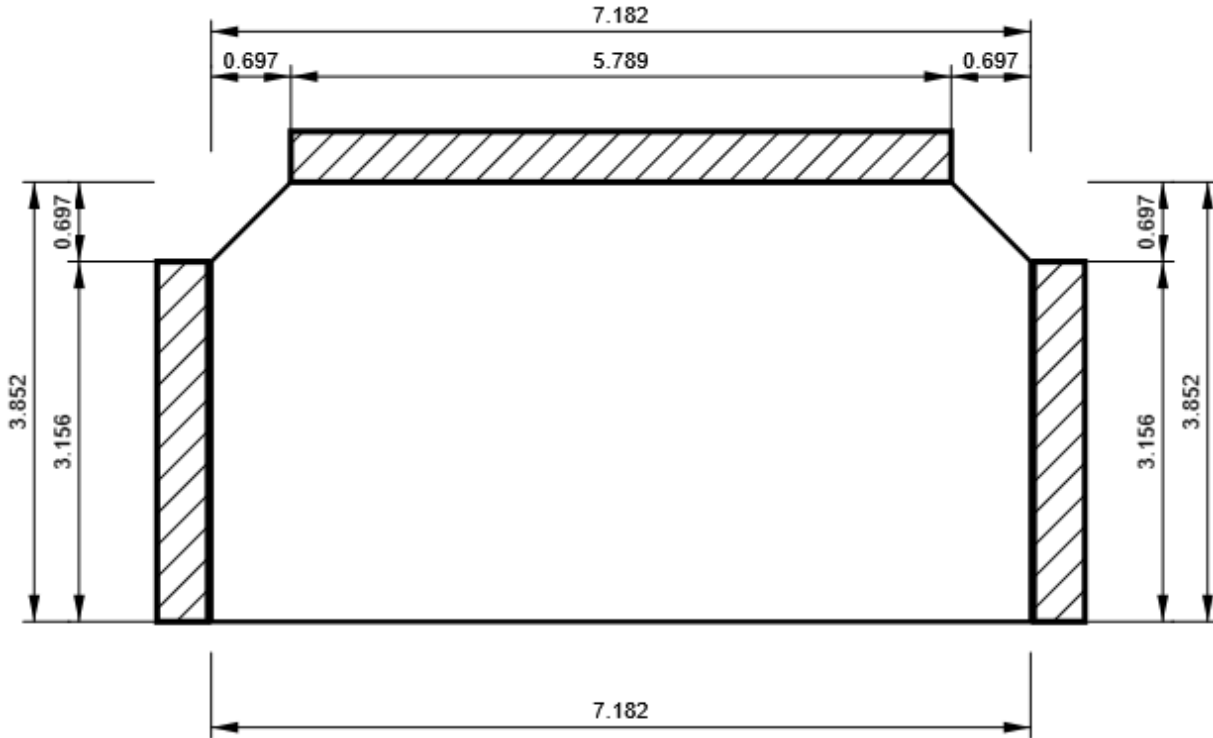

EP1

P9/16x19.209-4.646 (A36)

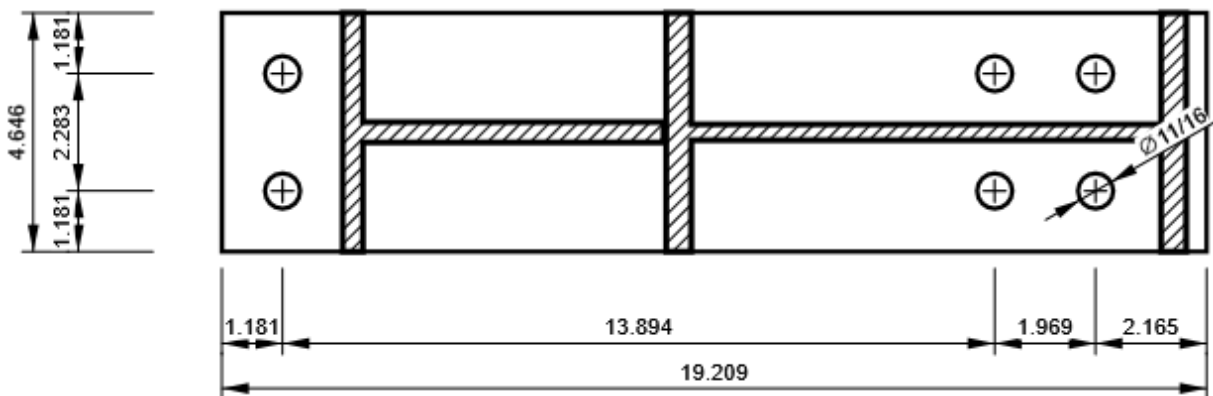

Project: Atlanta Industrial
Project no: 2021-1254-Z
Author: Dave the Engineer

WID1 - WID1a

P3/8x14.667-8.381 (A36)

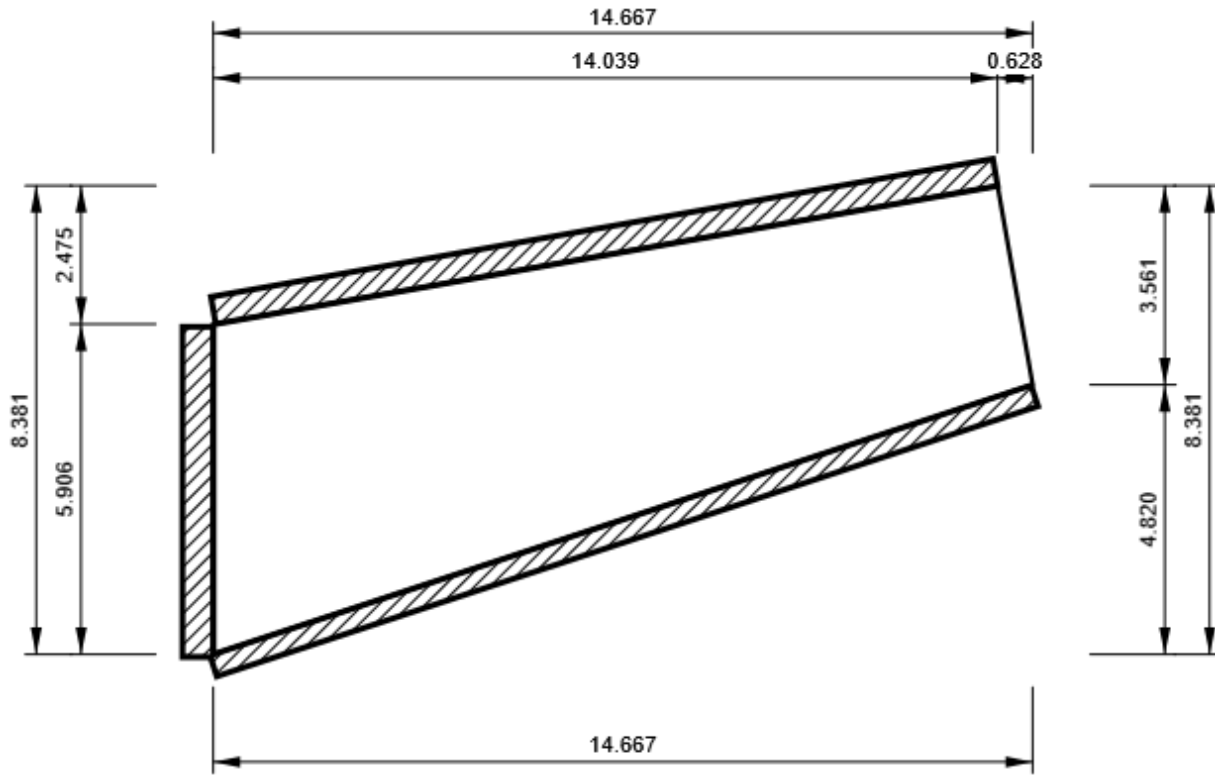

WID1 - WID1b

P3/8x15.475-4.724 (A36)

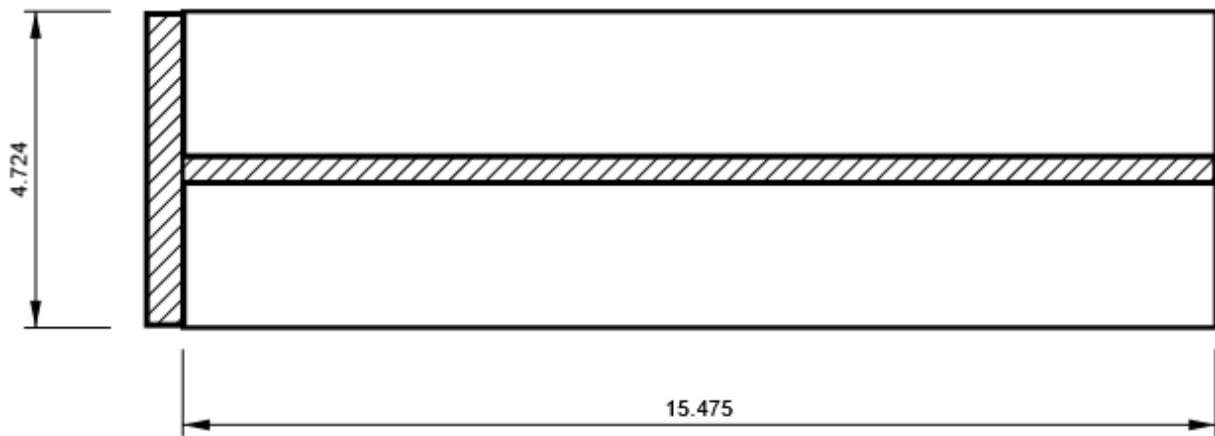

STIFF2

P3/8x7.142-3.852 (A36)

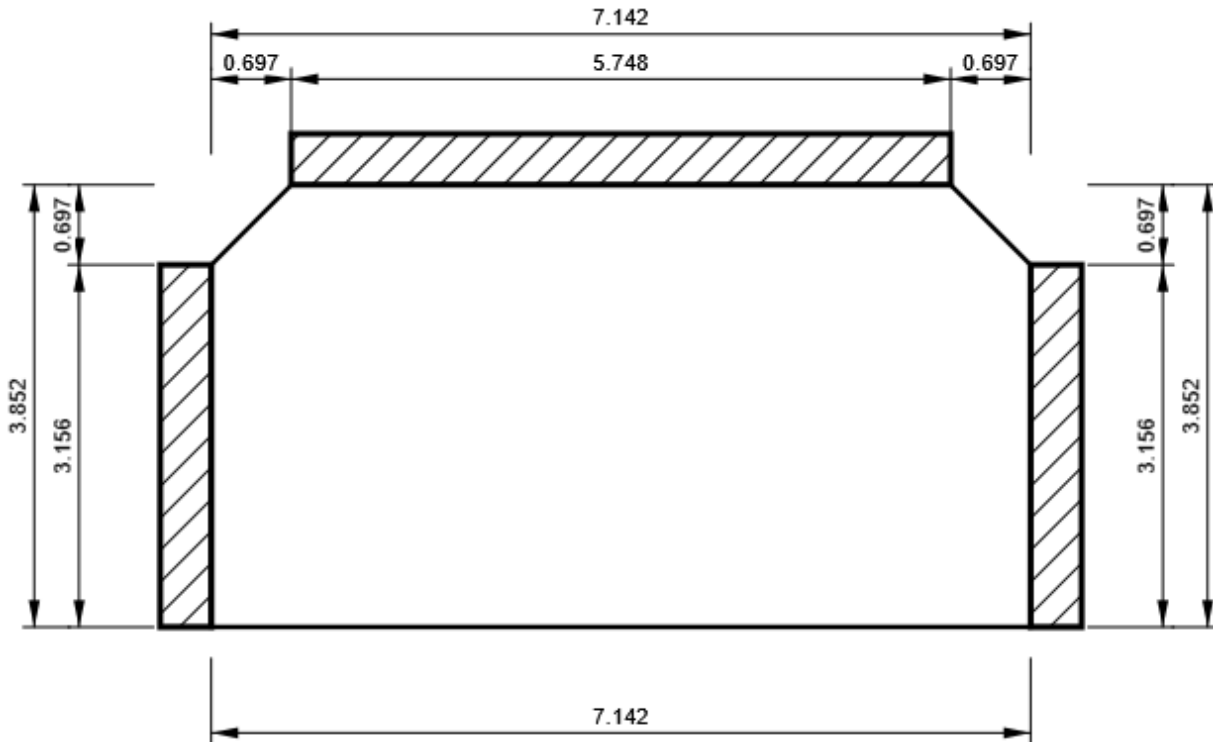

C, HP(Imp)8X36 - Top flange 1:

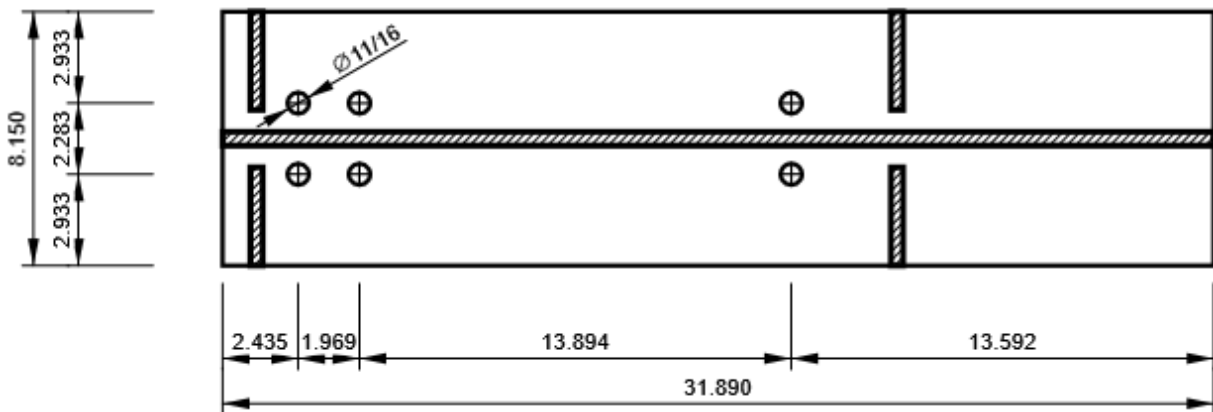

Code settings

Item	Value	Unit	Reference
Friction coefficient - concrete	0.40	-	ACI 349 – B.6.1.4
Friction coefficient in slip-resistance	0.30	-	AISC 360-16 J3.8
Limit plastic strain	0.05	-	
Weld stress evaluation	Plastic redistribution		
Detailing	No		
Distance between bolts [d]	2.66	-	AISC 360-16 – J3.3
Distance between bolts and edge [d]	1.25	-	AISC 360-16 – J.3.4
Concrete breakout resistance check	Both		

Project: Atlanta Industrial
Project no: 2021-1254-Z
Author: Dave the Engineer

Item	Value	Unit	Reference
Base metal capacity check at weld fusion face	No		AISC 360-16: J2-2
Cracked concrete	Yes		ACI 318-14 – Chapter 17
Local deformation check	No		
Local deformation limit	0.03	-	CIDECT DG 1, 3 - 1.1
Geometrical nonlinearity (GMNA)	Yes		Analysis with large deformations for hollow section joints

Theoretical Background

CBFEM versus AISC 360

The weak point of standard design method is in analyzing of internal forces and stress in a joint. CBFEM replaces specific analysis of internal forces in joint with general FEA.

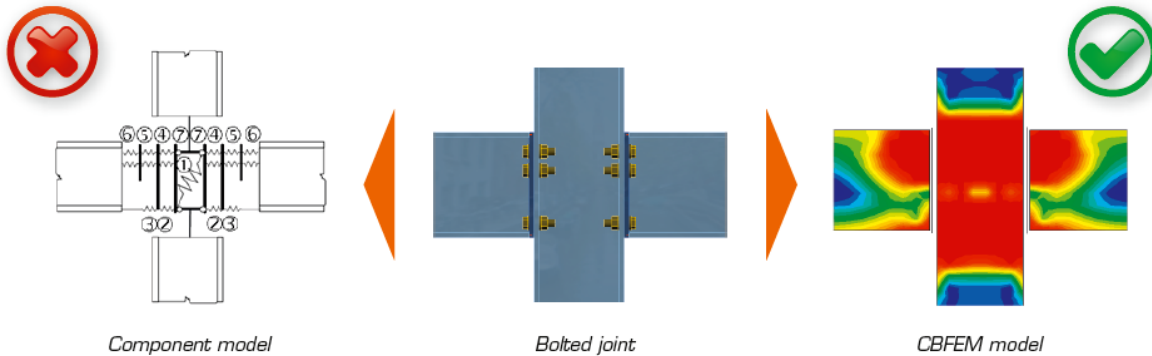

Check methods of specific components like bolts or welds are done according to standard AISC 360.

For the fasteners – bolts and welds – special FEM components had to be developed to model the welds and bolts behaviour in the connection. All parts of 1D members and all additional plates are modeled as plate/walls. These elements are made of steel (metal in general) and the behaviour of this material is significantly nonlinear.

The real stress-strain diagram of steel is replaced by the ideal plastic material for design purposes in building practice. The advantage of ideal plastic material is, that only yield strength and modulus of elasticity must be known to describe the material curve. The yield strength is multiplied by resistance factor (LRFD) or divided by safety factor (ASD) – AISC 360, Appendix 1. The granted ductility of construction steel is 15 %. The real usable value of limit plastic strain is 5% for ordinary design (EN 1993-1-5 appendix C paragraph C.8 note 1).

The stress in steel cannot exceed the yield strength when using the ideal elastic-plastic stress-strain diagram.

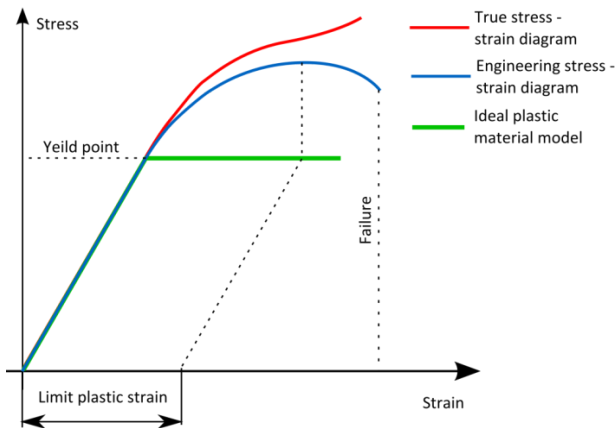

Real tension curve and the ideal elastic-plastic diagram of material

CBFEM method aims to model the real state precisely. Meshes of plates / walls are not merged, no intersections are generated between them, unlike it is used to when modeling structures and buildings. Mesh of finite elements is generated on each individual plate independently on mesh of other plates.

Between the meshes, special massless force interpolation constraints are added. They ensure the connection between the edge of one plate and the surface or edge of the other plate.

This unique calculation model provides very good results – both for the point of view of precision and of the analysis speed. The method is protected by patent.

The steel base plate is placed loosely on the concrete foundation. It is a contact element in the analysis model – the connection resists compression fully, but does not resist tension.

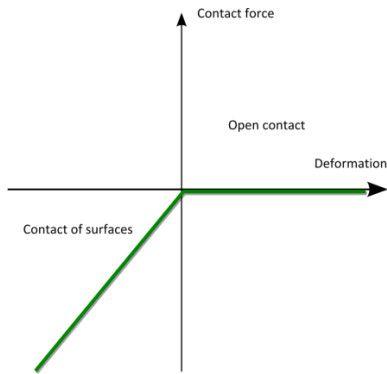

Stress-strain diagram of contact between the concrete block and the base plate

The concrete block in CBFEM is modeled using Winkler-Pasternak subsoil model. The stiffness of subsoil is determined using modulus of elasticity of concrete and effective height of subsoil. The concrete block is not designed by CBFEM method.

Welds are modeled using a special elastoplastic element, which is added to the interpolation links between the plates. The element respects the weld throat thickness, position and orientation. The plasticity state is controlled by stresses in the weld throat section. The plastic redistribution of stress in welds allows for stress peaks to be redistributed along the longer part of the weld.

Bolted connection consists of two or more clasped plates and one or more bolts. Plates are placed loosely on each other. A contact element is inserted between plates in the analysis model, which acts only in compression. No forces are carried in tension.

Shear force is taken by bearing. Special model for its transferring in the force direction only is implemented. IDEA StatiCa Connection can check bolts for interaction of shear and tension. The bolt behavior is implemented according to the following picture.

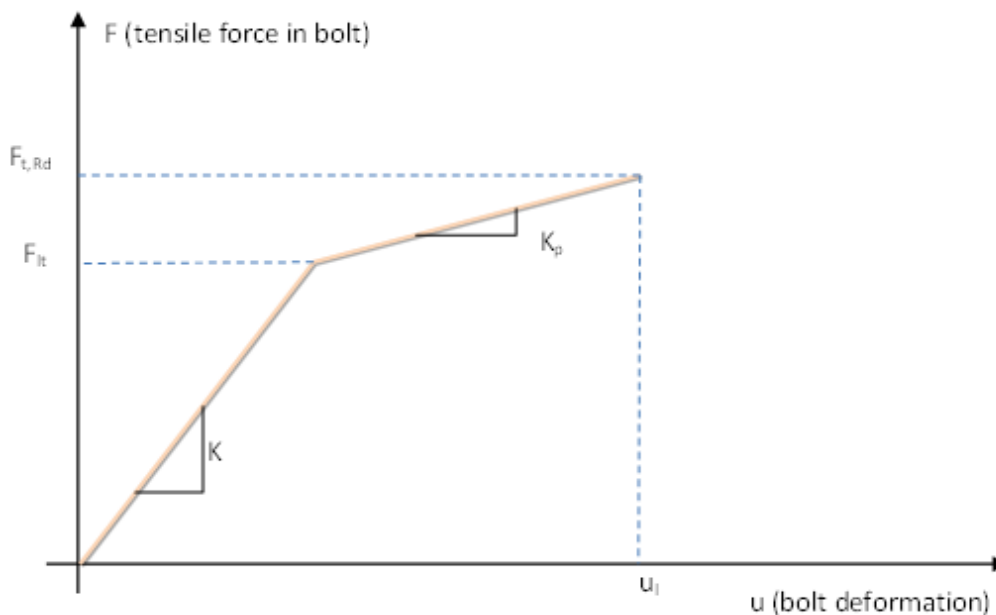

Bolt – tension

Symbols explanation:

- K – linear stiffness of bolt,
- K_p – stiffness of bolt at plastic branch,
- F_{lt} – limit force for linear behaviour of bolt,
- $F_{t,Rd}$ – limit bolt resistance,
- u_l – limit deformation of bolt.

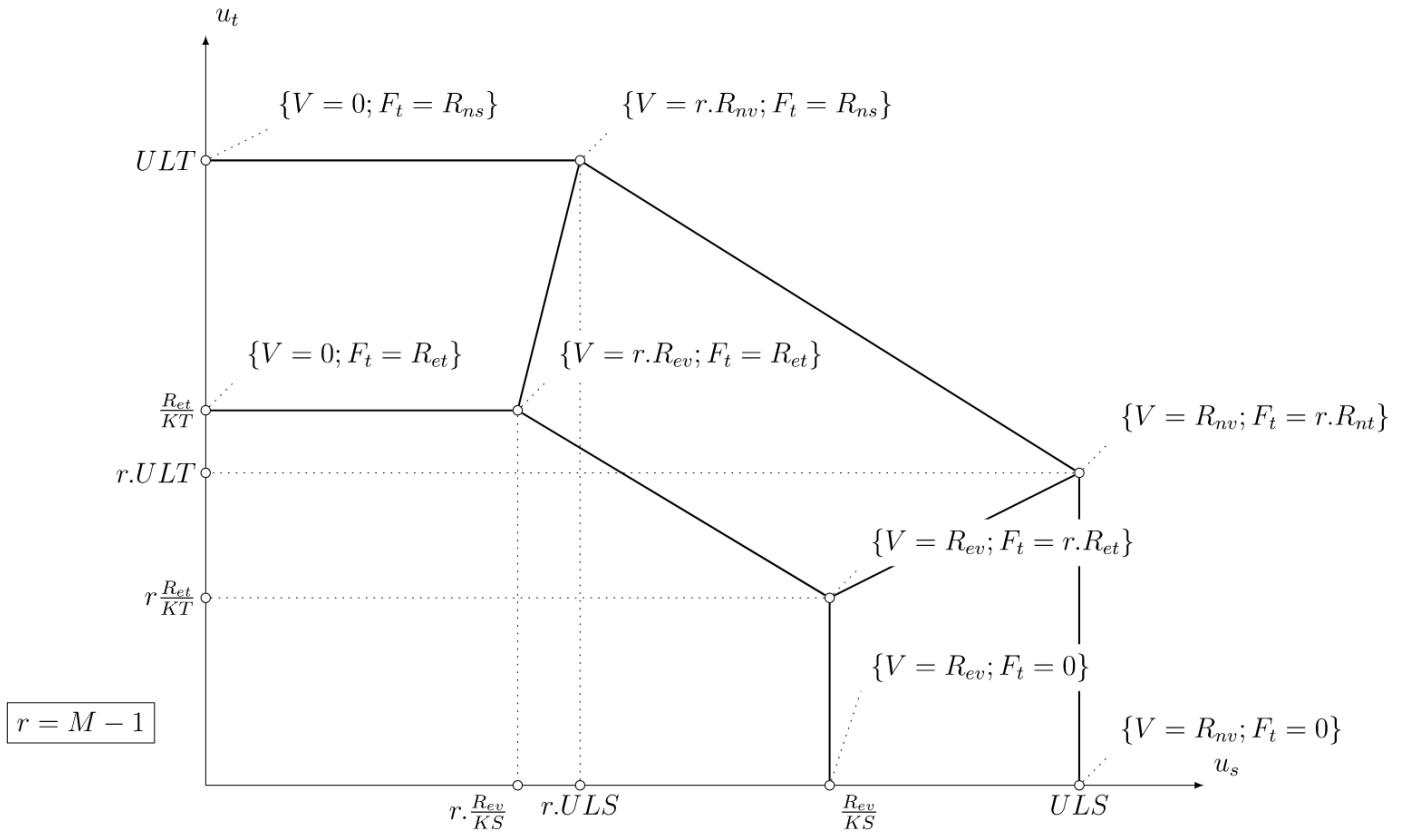

Bolt – interaction of shear and tension

Loads

End forces of member of the frame analysis model are transferred to the ends of member segments. Eccentricities of members caused by the joint design are respected during load transfer.

The analysis model created by CBFEM method corresponds to the real joint very precisely, whereas the analysis of internal forces is performed on very idealised 3D FEM bar model, where individual beams are modeled using centrelines and the joints are modeled using immaterial nodes.

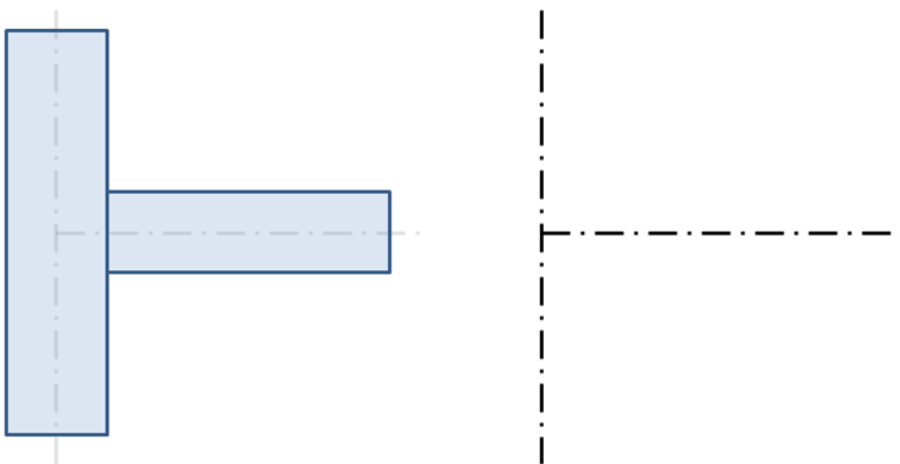

Joint of a vertical column and a horizontal beam

Internal forces are analysed using 1D members in 3D model. There is an example of courses of internal forces in the following picture.

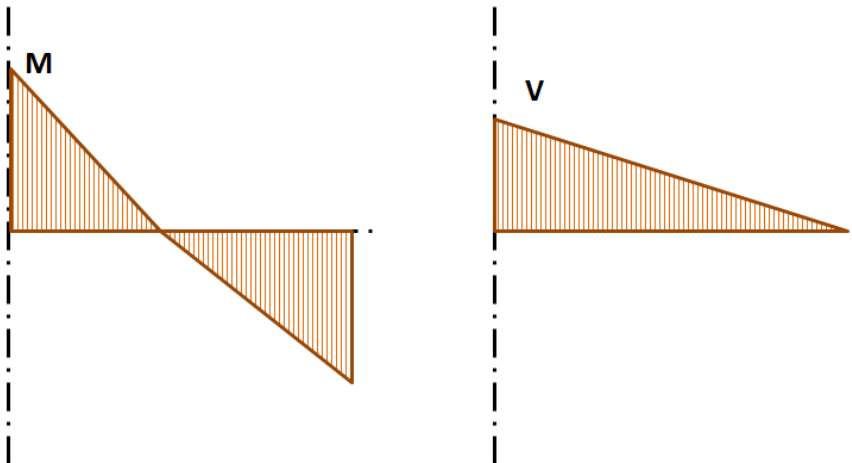

Internal forces in horizontal beam. M and V are the end forces at joint.

The effects caused by member on the joint are important to design the connection. The effects are illustrated in the following picture.

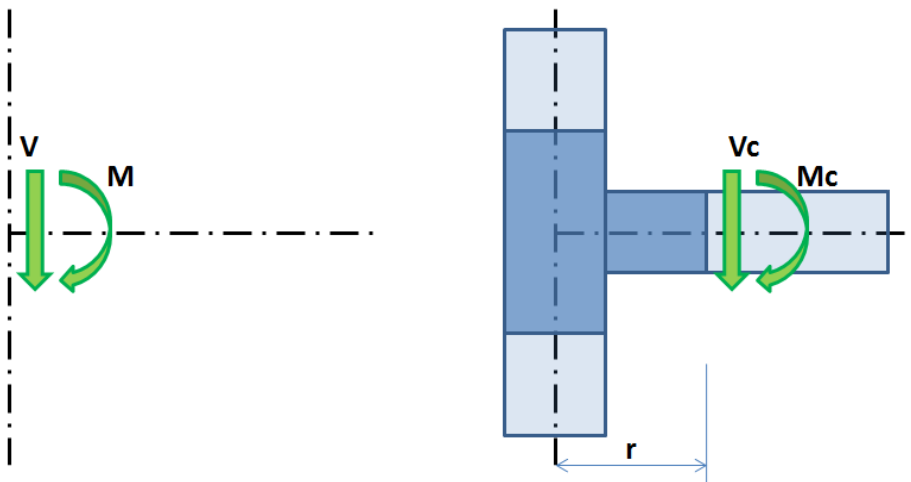

Effects of the member on the joint. CBFEM model is drawn in dark blue color.

Moment M and shear force V act in a theoretical joint. The point of theoretical joint does not exist in CBFEM model, thus the load cannot be applied here. The model must be loaded by actions M and V , which have to be transferred to the end of segment in the distance r .

$$M_c = M - V \cdot r$$

$$V_c = V$$

In CBFEM model, the end section of segment is loaded by moment M_c and force V_c .

Welds

Fillet welds

The design strength, ϕR_n and the allowable strength, R_n/Ω of welded joints are evaluated in connection weld check.

$$\phi = 0.75 \quad (\text{LRFD})$$

$$\Omega = 2.00 \quad (\text{ASD})$$

Available strength of welded joints is evaluated according to AISC 360 – J2.4:

$$R_n = F_{nw} A_{we}$$

$$F_{nw} = 0.60 F_{EXX} (1.0 + 0.50 \sin^{1.5} \Theta)$$

where

- F_{nw} – nominal stress of weld material,
- A_{we} – effective area of the weld,
- F_{EXX} – electrode classification number, i.e., minimum specified tensile strength,

- Θ – angle of loading measured from the weld longitudinal axis.

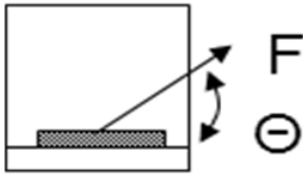

For long welds and welding to unstiffened flanges or webs of rectangular hollow sections, the weld material model is fine-tuned so that no reduction factor is necessary. The weld resistance is governed by most stressed weld element.

CJP groove welds

AISC Specification Table J2.5 identifies four loading conditions that might be associated with JP groove welds, and shows that the strength of the joint is either controlled by the base metal or that the loads need not be considered in the design of the welds connecting the parts. Accordingly, when CJP groove welds are made with matching-strength filler metal, the strength of a connection is governed or controlled by the base metal, and no checks on the weld strength are required.

Bolts

Tensile and shear strength of bolts

The design tensile or shear strength, ϕR_n , and the allowable tensile or shear strength, R_n / Ω of a snug-tightened bolt is determined according to the limit states of tension rupture and shear rupture as follows:

$$R_n = F_n A_b$$

$$\phi = 0.75 \quad (\text{LRFD})$$

$$\Omega = 2.00 \quad (\text{ASD})$$

where

- A_b – nominal unthreaded body area of bolt or threaded part,
- F_n – nominal tensile stress, F_{nt} , or shear stress, F_{nv} , from Table J3.2.

The tensile force, against which the required tensile strength is checked, includes any tension resulting from prying action produced by deformation of the connected parts.

Combined Tension and shear in bearing type connection

The available tensile strength of a bolt subjected to combined tension and shear is determined according to the limit states of tension and shear rupture as follows:

$$R_n = F'_{nt} A_b \quad (\text{AISC 360 J3-2})$$

$$\phi = 0.75 \quad (\text{LRFD})$$

$$\Omega = 2.00 \quad (\text{ASD})$$

$$F'_{nt} = 1.3 F_{nt} - f_{rv} F_{nt} / \phi F_{nv} \quad (\text{AISC 360 J3-3a LRFD})$$

$$F'_{nt} = 1.3 F_{nt} - f_{rv} \Omega F_{nt} / F_{nv} \quad (\text{AISC 360 J3-3b ASD})$$

where

- F'_{nt} – nominal tensile stress modified to include the effects of shear stress,
- F_{nt} – nominal tensile stress from AISC 360 – Tab. J3.2,
- F_{nv} – nominal shear stress from AISC 360 – Tab. J3.2,
- f_{rv} – required shear stress using LRFD or ASD load combinations. The available shear stress of the fastener shall be equal or exceed the required shear stress, f_{rv} .

Bearing strength in bolt holes

The available bearing strength, ϕR_n and R_n / Ω at bolt holes is determined for the limit state of bearing as follows:

For a bolt in a connection with standard holes:

$$R_n = 1.2 l_c t F_u \leq 2.4 d t F_u \quad (\text{AISC 360 J3-6a, c})$$

For a bolt in a connection with slotted holes:

$$R_n = 1.0 l_c t F_u \leq 2.0 d t F_u \quad (\text{AISC 360 J3-6e, f})$$

$$\phi = 0.75 \quad (\text{LRFD})$$

$$\Omega = 2.00 \quad (\text{ASD})$$

where

Project: Atlanta Industrial
Project no: 2021-1254-Z
Author: Dave the Engineer

- F_u – specified minimum tensile strength of the connected material,
- d – nominal bolt diameter,
- l_c – clear distance, in the direction of the force, between the edge of the hole and the edge of the adjacent hole or edge of the material,
- t – thickness of connected material.

Preloaded bolts

The design slip resistance of a preloaded class A325 or A490 bolt with of effect of tensile force, $F_{t,Ed}$ according to AISC 360 – J3.9.

Preloading force to be used AISC 360 – Tab. J3.1.

$$T_b = 0.7 f_{ub} A_s$$

Design slip resistance per bolt AISC 360 – J3.8

$$R_n = 1.13 \mu T_b N_s$$

Utilisation in shear [%]:

$$U_{ts} = V / R_n$$

where

- A_s – tensile stress area of the bolt,
- f_{ub} – ultimate tensile strength,
- μ – mean slip factor coefficient,
- N_s – number of the friction surfaces. Check is calculated for each friction surface separately,
- V – shear force.

Anchors

The anchor bolt element is elastic-plastic with significant strain hardening. The maximum steel tensile resistance is expected at the strain which equals to $0.25 \times$ guaranteed elongation. The failure mode due to concrete cracking may occur before the anchor steel tensile resistance is reached and is considered as a completely brittle failure.

Similarly, the steel components in shear (anchor bolt, base plate in bearing) are able to yield but failure modes connected with concrete cracking may occur suddenly as a brittle failure.

All standards use Concrete Capacity Design method developed by prof. R. Eligehausen at University of Stuttgart. The theory is based on vast experimental and numerical testing mostly on unreinforced concrete blocks and relatively short, often post-installed, anchors.

Anchorage is designed according to ACI 318-14 – Chapter 17. The design is available only for LRFD. Some failure modes (e.g. steel resistance) are evaluated for single anchors, others (e.g. concrete breakout) are checked for group of anchors.

Software info

Application	IDEA StatiCa Connection
Version	21.0.0.2598
Developed by	IDEA StatiCa